

SERVICE MANUAL

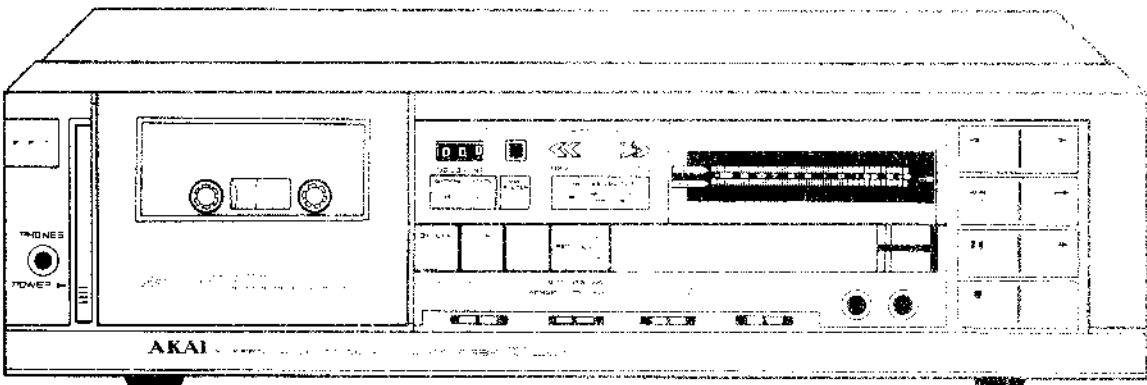
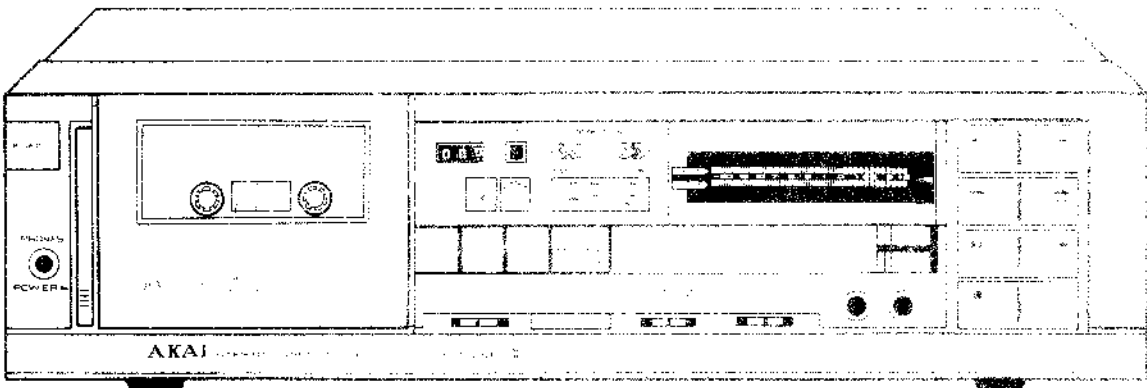

STEREO CASSETTE DECK

MODEL **CS-F36R**

MODEL **CS-F39R**

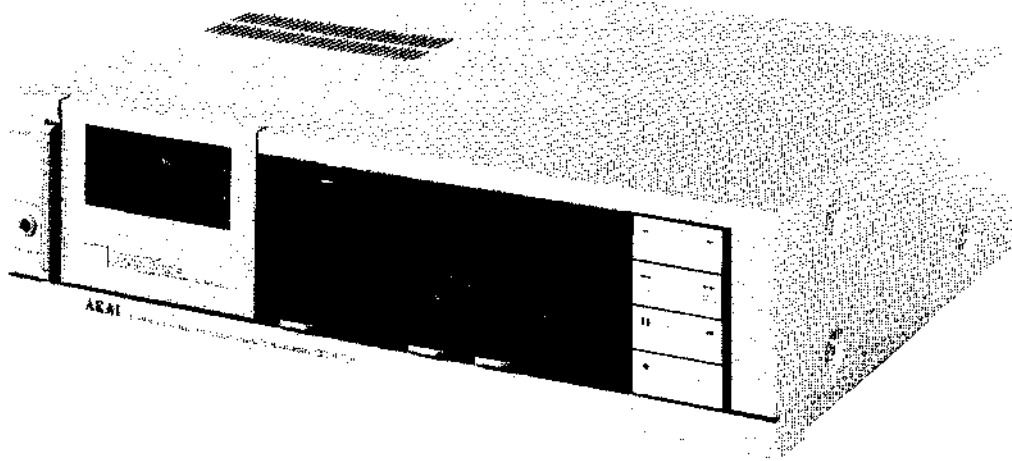

CS-F36R

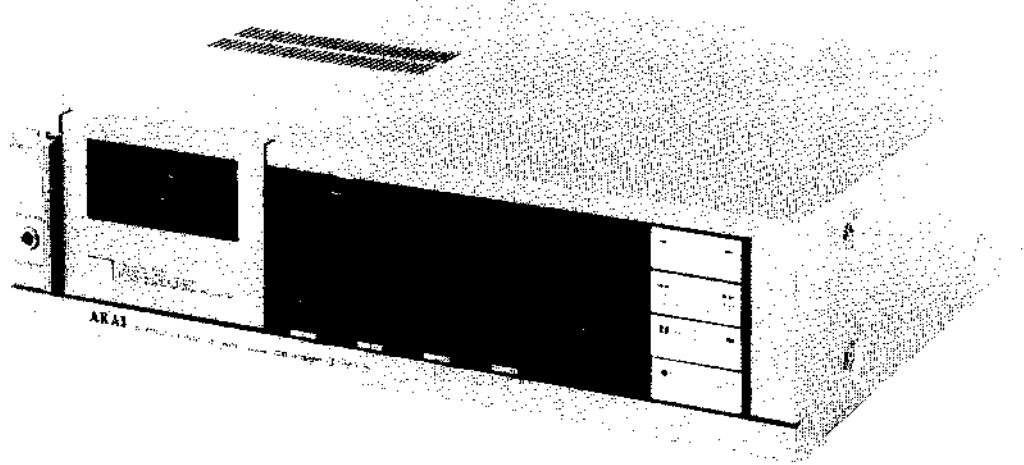

CS-F39R

STEREO CASSETTE DECK

CS-F36R
MODEL CS-F39R

THIS MANUAL IS APPLICABLE TO BOTH SILVER
AND PEARL SHADOW PANEL MODELS

SECTION 1	SERVICE MANUAL	3
SECTION 2	PARTS LIST	37
SECTION 3	SCHEMATIC DIAGRAM	65

SAFETY INSTRUCTIONS

SAFETY CHECK AFTER SERVICING

Confirm the specified insulation resistance between power cord plug prongs and externally exposed parts of the set is greater than 10 Mohms, but for equipment with external antenna terminals (tuner, receiver, etc.) and is intended for **C** or **A**, specified insulation resistance should be more than 2.2 Mohms (ground terminals, microphone jacks, headphone jacks, line-in-out jacks etc.)

PRECAUTIONS DURING SERVICING

1. Parts identified by the Δ symbol parts are critical for safety.
Replace only with parts number specified.
2. In addition to safety, other parts and assemblies are specified for conformance with such regulations as those applying to spurious radiation. These must also be replaced only with specified replacements.
Examples: RF converters, tuner units, antenna selector switches, RF cables, noise blocking capacitors, noise blocking filters, etc.
3. Use specified internal wiring. Note especially:
 - 1) Wires covered with PVC tubing
 - 2) Double insulated wires
 - 3) High voltage leads
4. Use specified insulating materials for hazardous live parts. Note especially:
 - 1) Insulation Tape
 - 2) PVC tubing
 - 3) Spacers (Insulating Barriers)
 - 4) Insulation sheets for transistors
5. When replacing AC primary side components (transformers, power cords, noise blocking capacitors, etc.), wrap ends of wires securely about the terminals before soldering.

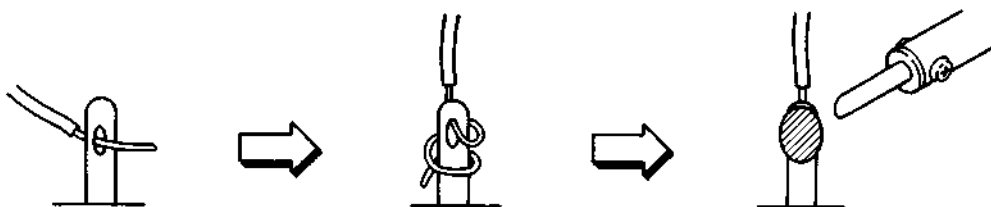

6. Observe that wires do not contact heat producing parts (heatsinks, oxide metal film resistors, fusible resistors, etc.).
7. Check that replaced wires do not contact sharp edged or pointed parts.
8. Also check areas surrounding repaired locations.
9. Use care that foreign objects (screws, solder droplets, etc.) do not remain inside the set.

SECTION 1

SERVICE MANUAL

TABLE OF CONTENTS

I. SPECIFICATIONS	4
1. Model CS-F36R	4
2. Model CS-F39R	5
II. DISMANTLING OF UNIT	6
III. CONTROLS	7
1. Model CS-F36R	7
2. Model CS-F39R	8
IV. PRINCIPAL PARTS LOCATION	9
1. Model CS-F36R	9
2. Model CS-F39R	10
V. VOLTAGE AND CYCLE CONVERSION	11
VI. MECHANICAL ADJUSTMENT	12
VII. HEAD ADJUSTMENT	15
VIII. ELECTRICAL ADJUSTMENT	17
1. QUICK REVERSE SENSITIVITY ADJUSTMENT	17
2. AMPLIFIER ADJUSTMENT	18
IX. DC RESISTANCE OF VARIOUS COILS	21
X. CLASSIFICATION OF VARIOUS P.C BOARDS	22
1. P.C BOARD TITLES AND IDENTIFICATION NUMBERS	22
2. COMPOSITION OF VARIOUS P.C BOARDS	23

For basic adjustments, measuring methods, and operating principles, refer to GENERAL TECHNICAL MANUAL.

I. SPECIFICATIONS

1. Model CS-F36R

TRACK SYSTEM	4 Track 2 Channel Stereo System
TAPE	Philips Type Cassette
TAPE SPEED	4.76 cm/s $\pm 1.0\%$ (1-7/8 ips. $\pm 1.0\%$)
HEADS	High Density Metallic head for recording/playback $\times 1$ Erase head $\times 2$
MOTORS	Electronically speed controlled D.C. motor for capstan drive $\times 1$ D.C. motor for reel drive $\times 1$
WOW & FLUTTER	0.12% WTD (DIN) 0.04% WRMS
TAPE WINDING TIME	90 sec. using a C-60 cassette tape
FREQUENCY RESPONSE	Normal: 25 to 16,000 Hz ± 3 dB CrO ₂ : 25 to 17,000 Hz ± 3 dB Metal: 25 to 18,000 Hz ± 3 dB
FREQUENCY EXTENT	Normal: 20 to 17,000 Hz CrO ₂ : 20 to 18,000 Hz Metal: 20 to 19,000 Hz
SIGNAL TO NOISE RATIO	60 dB (measured via tape with peak recording level) Dolby NR switch ON: Improves up to 5 dB at 1 kHz, 10 dB above 5 kHz
HARMONIC DISTORTION	1 kHz, 3rd harmonic distortion
INPUT	MIC: 0.25 mV (600 ohms) Line: 70 mV (47 kohms)
OUTPUT	Line: 410 mV (less than 2 kohms) Phone: 0.3 mW (8 ohms)
DIN	Input: 2.0 mV (10 kohms) Output: 410 mV
POWER REQUIREMENTS	100V 50/60 Hz for JPN 120V, 60Hz for USA and Canada 220V, 50Hz for Europe except UK 240V, 50Hz for UK and Australia 110V/120V/220V/240V, 50/60 Hz switchable for other countries.
POWER CONSUMPTION	U, J, A, C 20W
DIMENSIONS	440(W) \times 118(H) \times 309(D) mm (17.3 \times 4.6 \times 12.2")
WEIGHT	7.6 kg (16.7 lbs)

* For improvement purposes, specifications and design are subject to change without notice.

* "Dolby" and the Double D symbol are trademarks of Dolby Laboratories.
(Manufactured under license from Dolby Laboratories).

2. Model CS-F39R

TRACK SYSTEM	4 Track 2 Channel Stereo System
TAPE SPEED	4.76 cm/s \pm 1.0% (1-7/8 ips. \pm 1.0%)
HEADS	High Density Metallic head for recording/playback \times 1 Erase head \times 2
MOTORS	Electronically speed controlled D.C. motor for capstan drive \times 1 D.C. motor for reel drive \times 1
WOW & FLUTTER	0.12% WTD (DIN) 0.04% WRMS
TAPE WINDING TIME	90 sec. using a C-60 cassette tape
FREQUENCY RESPONSE	Normal: 25 to 16,000 Hz \pm 3 dB CrO ₂ : 25 to 17,000 Hz \pm 3 dB Metal: 25 to 18,000 Hz \pm 3 dB
FREQUENCY RANGE	Normal: 20 to 17,000 Hz CrO ₂ : 20 to 18,000 Hz Metal: 20 to 19,000 Hz
SIGNAL TO NOISE RATIO	60 dB (measured via tape with peak recording level) Dolby B-type NR switch ON: Improves up to 5 dB at 1 kHz, 10 dB above 5 kHz Dolby-C-type NR switch ON: Improves up to 15 dB at 500 Hz, 20 dB at 1 kHz to 10 kHz
HARMONIC DISTORTION	1 kHz, 3rd harmonic distortion
INPUT	MIC: 0.25 mV (600 ohms) Line: 70 mV (47 kohms)
OUTPUT	Line: 410 mV (less than 2 kohms) Phone: 0.3 mW (8 ohms)
DIN	Input: 2.0 mV (10 kohms) Output: 410 mV
POWER REQUIREMENTS	100V 50/60 Hz for JPN 120V, 60Hz for USA and Canada 220V, 50Hz for Europe except UK 240V, 50Hz for UK and Australia 110V/120V/220V/240V, 50/60 Hz switchable for other countries.
POWER CONSUMPTION	U,J,A,C 20W
DIMENSIONS	440(W) \times 118(H) \times 309(D) mm (17.3 \times 4.6 \times 12.2")
WEIGHT	7.6 kg (16.7 lbs)

* For improvement purposes, specifications and design are subject to change without notice.

* "Dolby" and the Double D symbol are trademarks of Dolby Laboratories.
(Manufactured under license from Dolby Laboratories).

II. DISMANTLING OF UNIT

In case of trouble, etc. necessitating dismantling, please dismantle in the order shown in the photographs. Reassemble in reverse order.

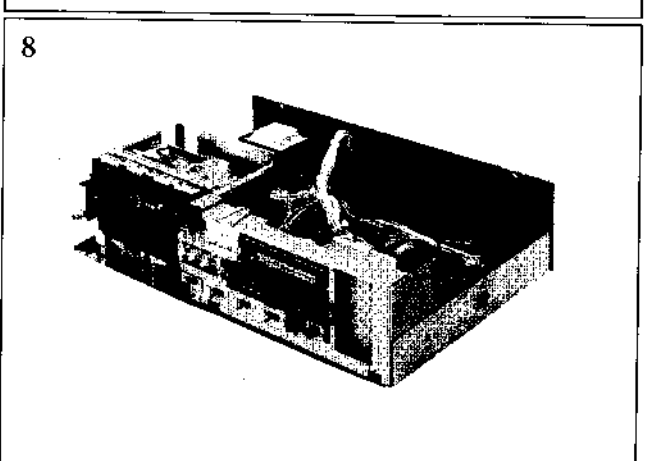
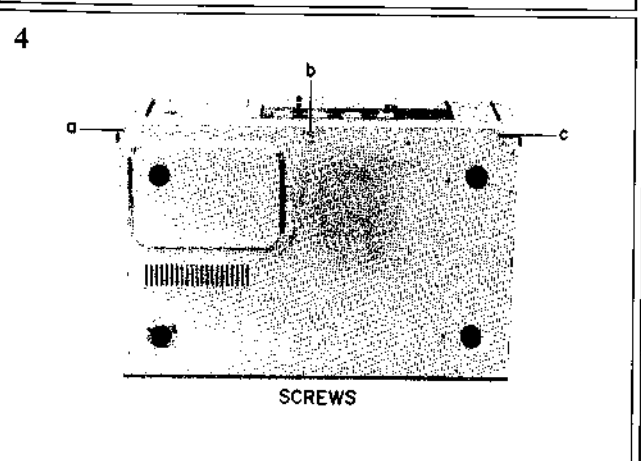
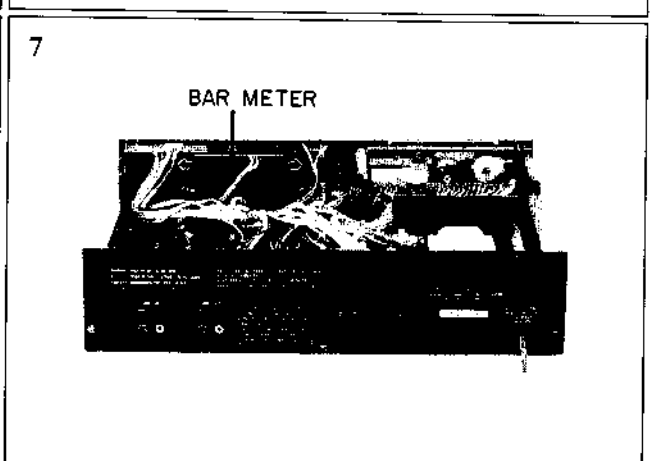
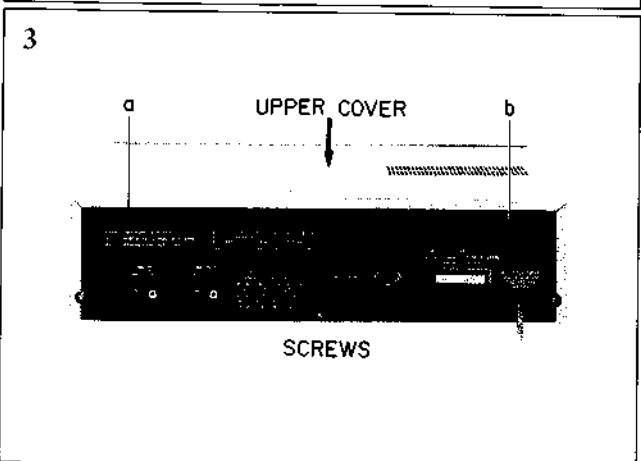
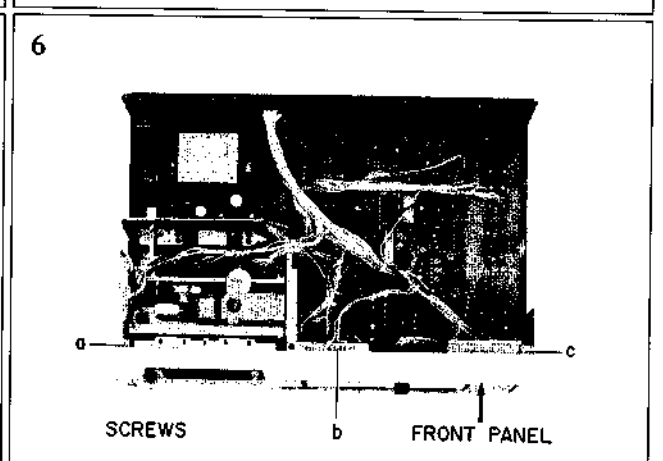
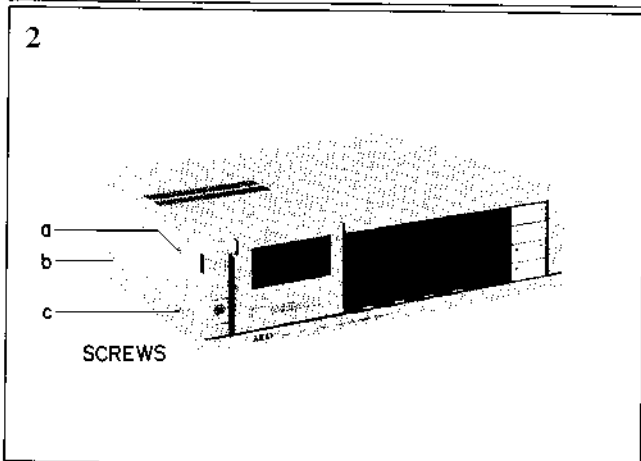
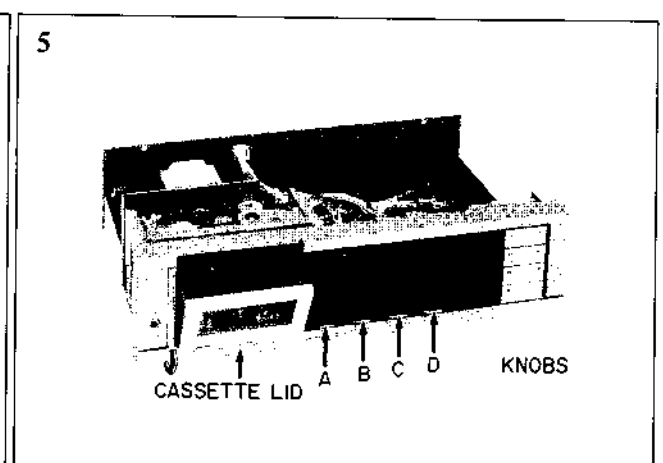
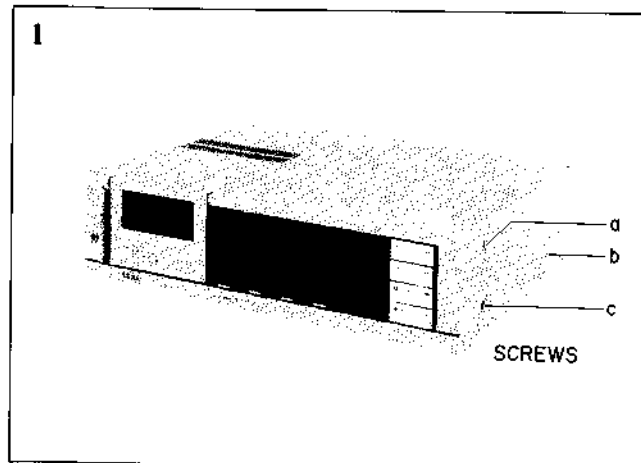

III. CONTROLS

1. Model CS-F36R

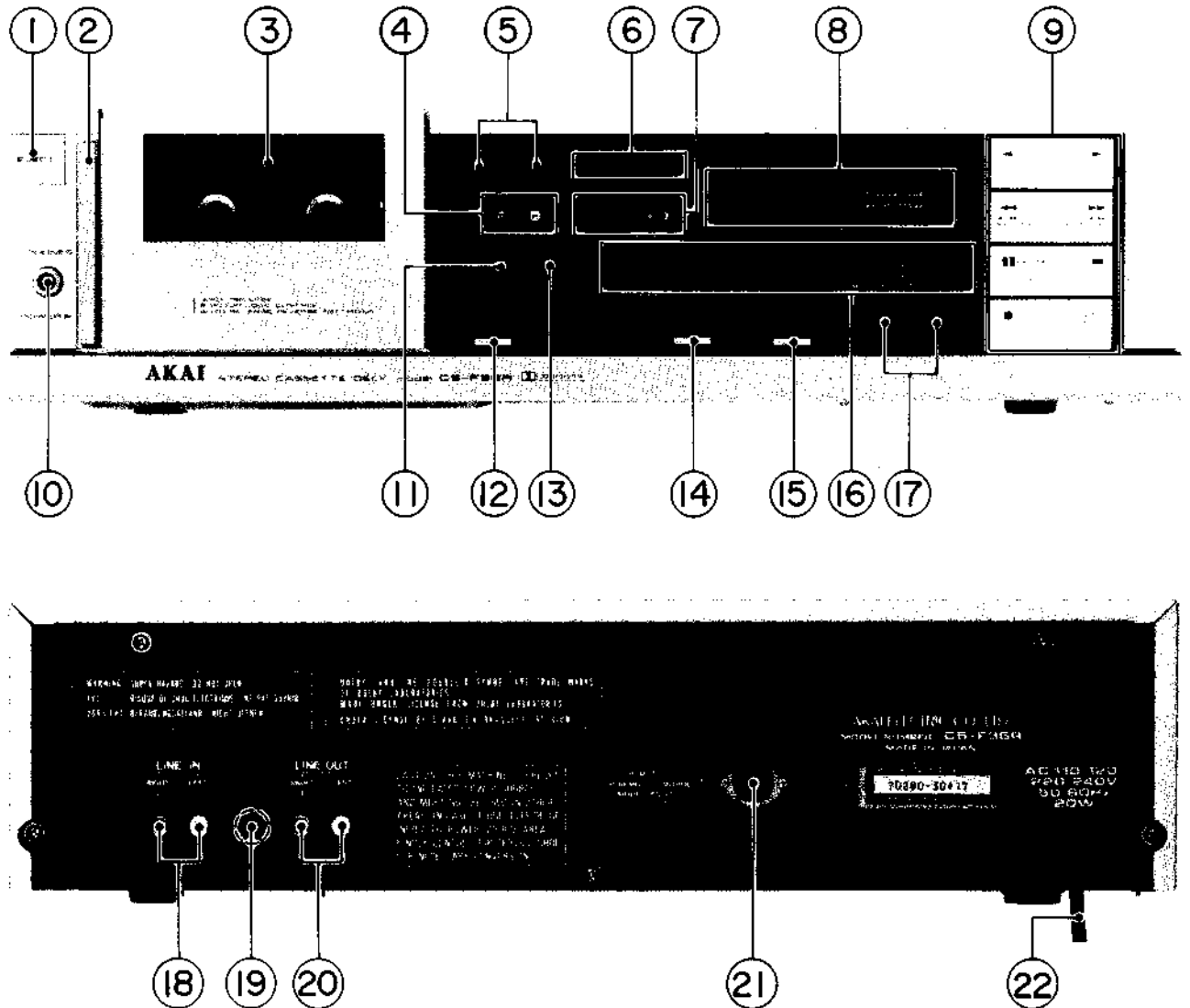

Fig. 1 Controls

- | | |
|--|---|
| <ul style="list-style-type: none"> 1. EJECT BUTTON 2. POWER SWITCH 3. CASSETTE RECEPTACLE 4. DOLBY NR and MPX FILTER INDICATORS 5. TAPE COUNTER and RESET BUTTON 6. DIRECTION INDICATORS 7. REVERSE (REV) SELECTOR INDICATORS 8. FLD BAR METER 9. OPERATING BUTTONS
 REVERSE (◀) BUTTON
 FORWARD (▶) BUTTON
 REWIND (◀◀) BUTTON
 FAST FORWARD (▶▶) BUTTON
 STOP (■) BUTTON
 PAUSE () BUTTON with INDICATOR
 AUTO MUTE BUTTON
 RECORDING [REC (●)] BUTTON with INDICATOR | <ul style="list-style-type: none"> 10. HEADPHONE (PHONES) JACK 11. DOLBY NR SWITCH 12. TIMER START SELECTOR 13. MPX FILTER SWITCH 14. REVERSE (REV) SELECTOR 15. TAPE SELECTOR 16. RECORDING (REC) LEVEL CONTROLS 17. MICROPHONE (MIC-L: left, MIC-R: right) JACKS 18. LINE IN JACKS 19. DIN JACK
(Some models are not equipped with this facility.) 20. LINE OUT JACKS 21. REMOTE JACK 22. POWER CORD (Some models are equipped with an AC Inlet instead. Connect with the connection cord supplied.) |
|--|---|

2. Model CS-F39R

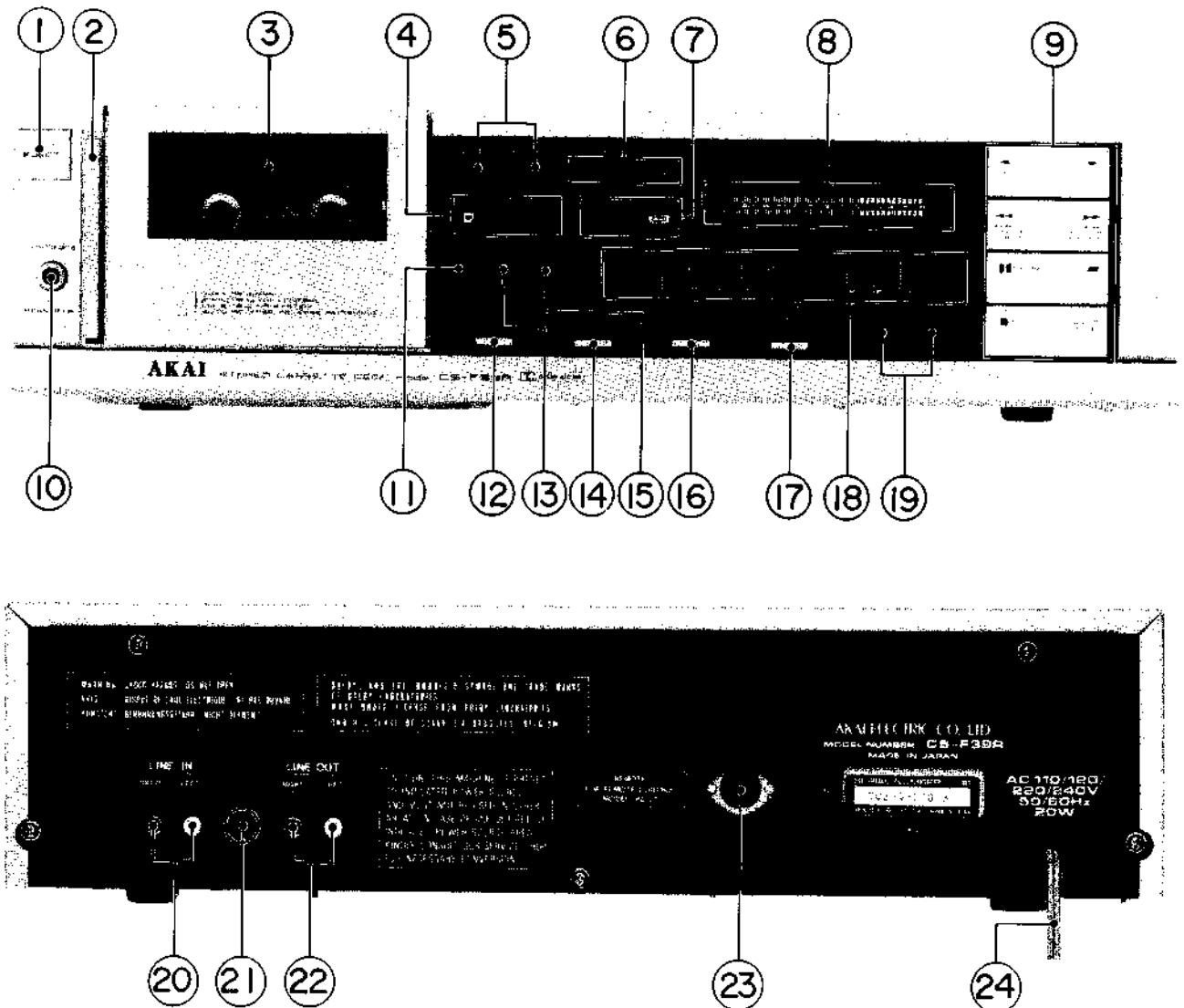

Fig. 2 Controls

- | | |
|---|--|
| 1. EJECT BUTTON | 10. HEADPHONE (PHONES) JACK |
| 2. POWER SWITCH | 11. DOLBY NR ON/OFF SWITCH |
| 3. CASSETTE RECEPTACLE | 12. TIMER START SELECTOR |
| 4. DOLBY NR (B-TYPE and C-TYPE) and MPX FILTER INDICATORS | 13. DOLBY B-TYPE/C-TYPE SELECTOR |
| 5. TAPE COUNTER and RESET BUTTON | 14. AUTO SYSTEM SELECTOR |
| 6. DIRECTION INDICATORS | 15. MPX FILTER SWITCH |
| 7. REVERSE (REV) SELECTOR INDICATORS | 16. REVERSE (REV) SELECTOR |
| 8. FLD BAR METER | 17. TAPE SELECTOR |
| 9. OPERATING BUTTONS | 18. RECORDING (REC) LEVEL CONTROLS |
| REVERSE (◀) BUTTON | 19. MICROPHONE (MIC-L: left, MIC-R: right) JACKS |
| FORWARD (▶) BUTTON | 20. LINE IN JACKS |
| REWIND (◀◀) BUTTON | 21. DIN JACK |
| FAST FORWARD (▶▶) BUTTON | (Some models are not equipped with this facility.) |
| STOP (■) BUTTON | 22. LINE OUT JACKS |
| PAUSE () BUTTON with INDICATOR | 23. REMOTE JACK |
| AUTO MUTE BUTTON | 24. POWER CORD (Some models are equipped with an AC Inlet instead. Connect with the connection cord supplied.) |
| RECORDING (REC (●)) BUTTON with INDICATOR | |

IV. PRINCIPAL PARTS LOCATION

1. Model CS-F36R

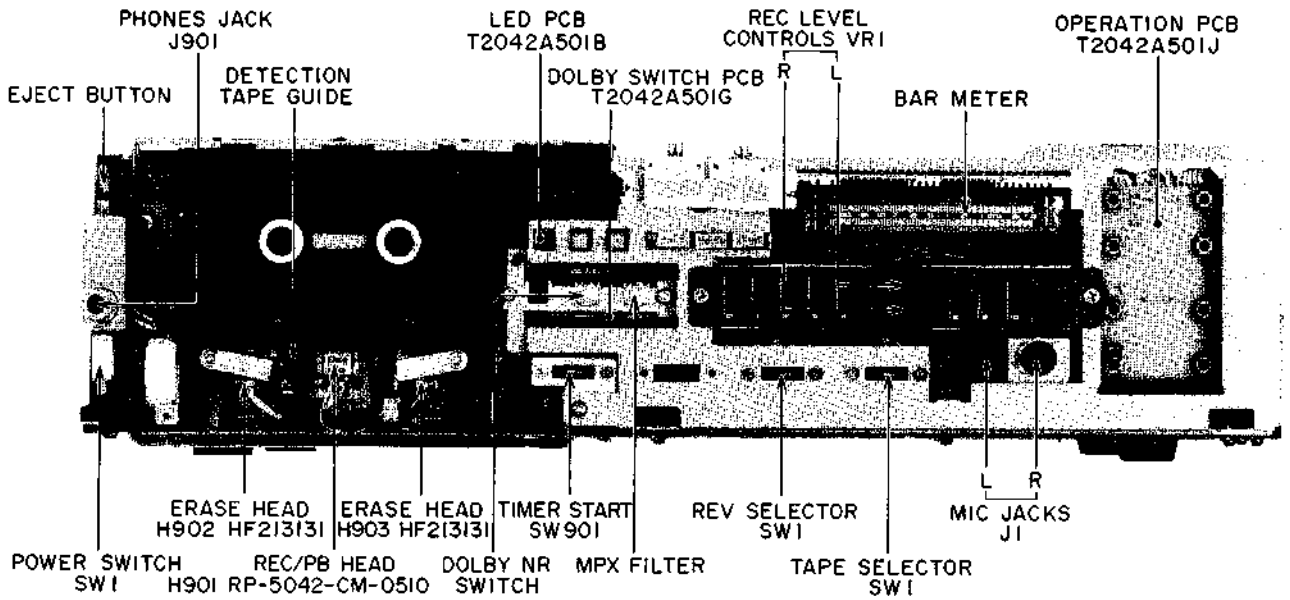

Fig. 3 Front View

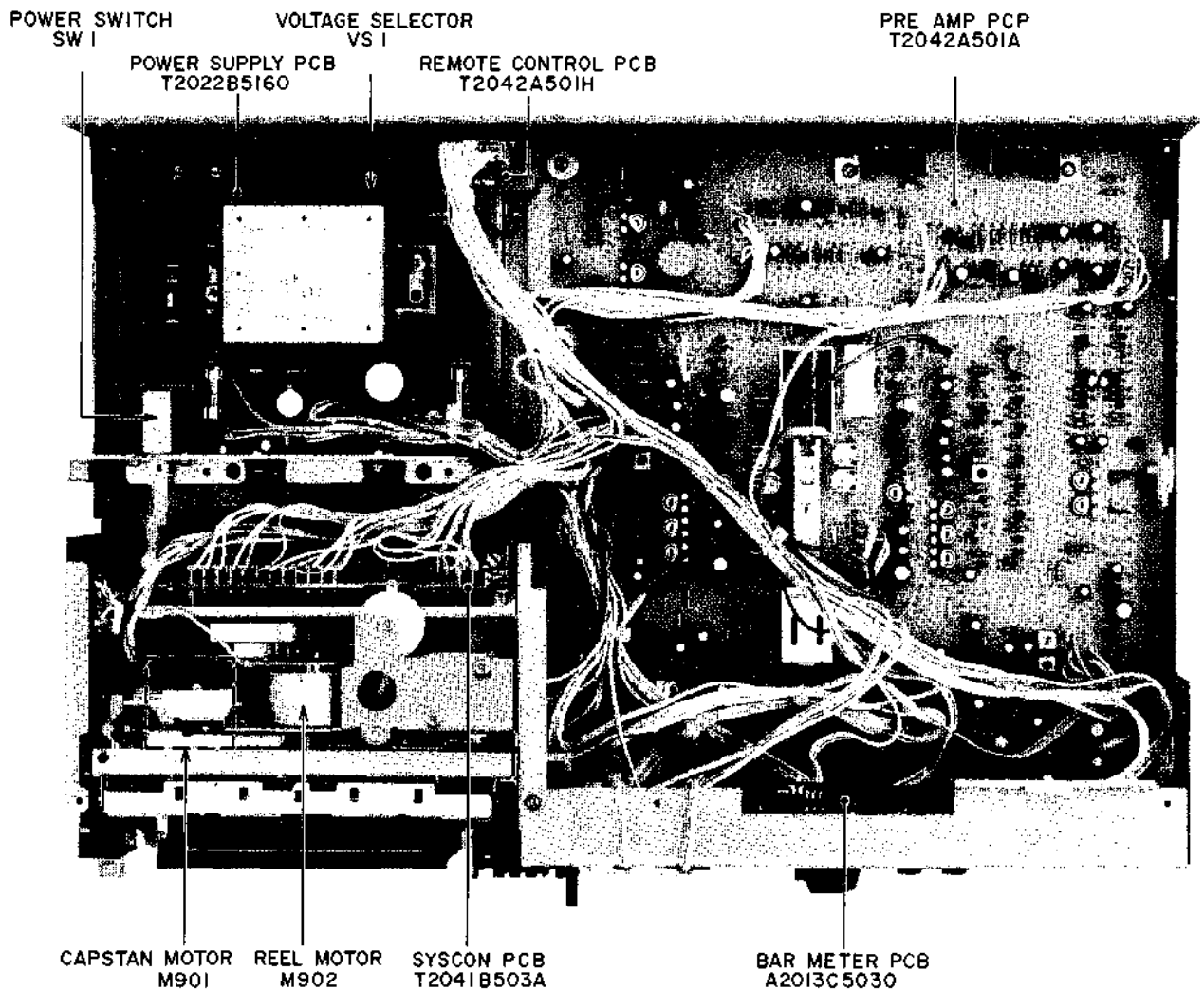

Fig. 4 Top View

2. Model CS-F39R

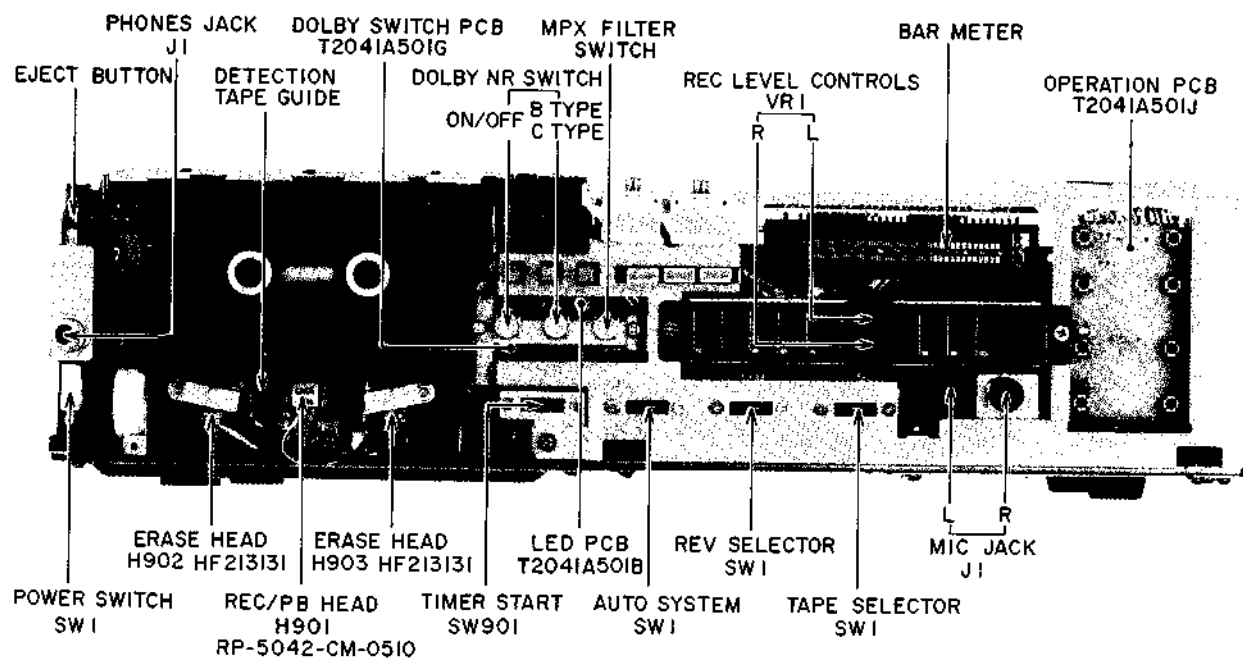

Fig. 5 Front View

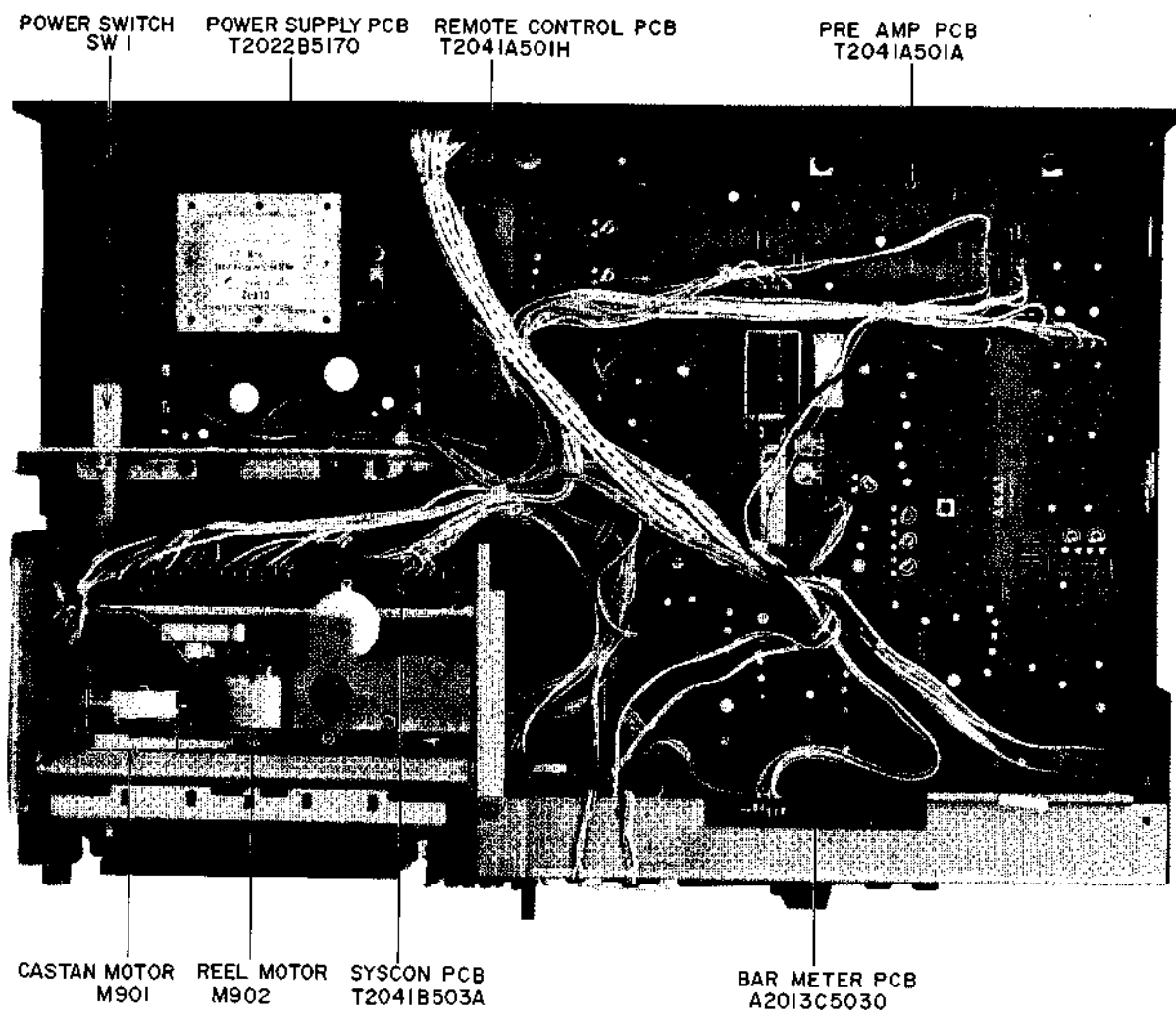

Fig. 6 Top View

V. VOLTAGE AND CYCLE CONVERSION

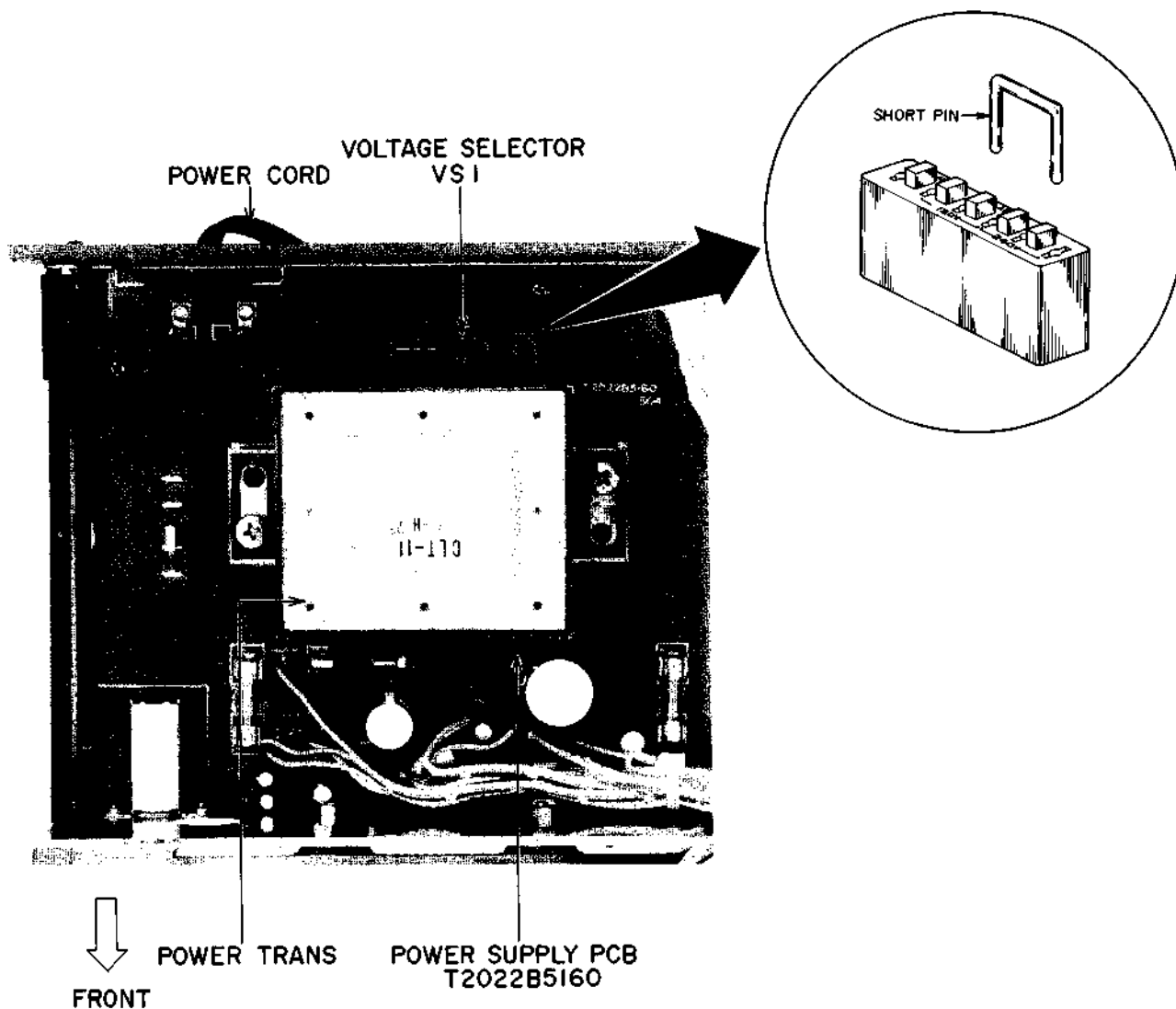

Fig. 7 Voltage Conversion (U/T Model only)

1. VOLTAGE CONVERSION

Models for Canada, Europe, USA, UK, Australia and Japan are not equipped with this facility.

Each machine is preset at the factory according to destination, but some machines can be set to 110V, 120V, 220V or 240V as required.

If voltage change is necessary, this can be accomplished as follows:

- 1) Disconnect power cord.
- 2) Loosen holding screws and remove upper cover.
- 3) Remove short pin plug from present holes and replace in correct holes. Follow the markings explicitly.

2. CYCLE CONVERSION

With DC motor, cycle conversion is not necessary.

VI. MECHANICAL ADJUSTMENT

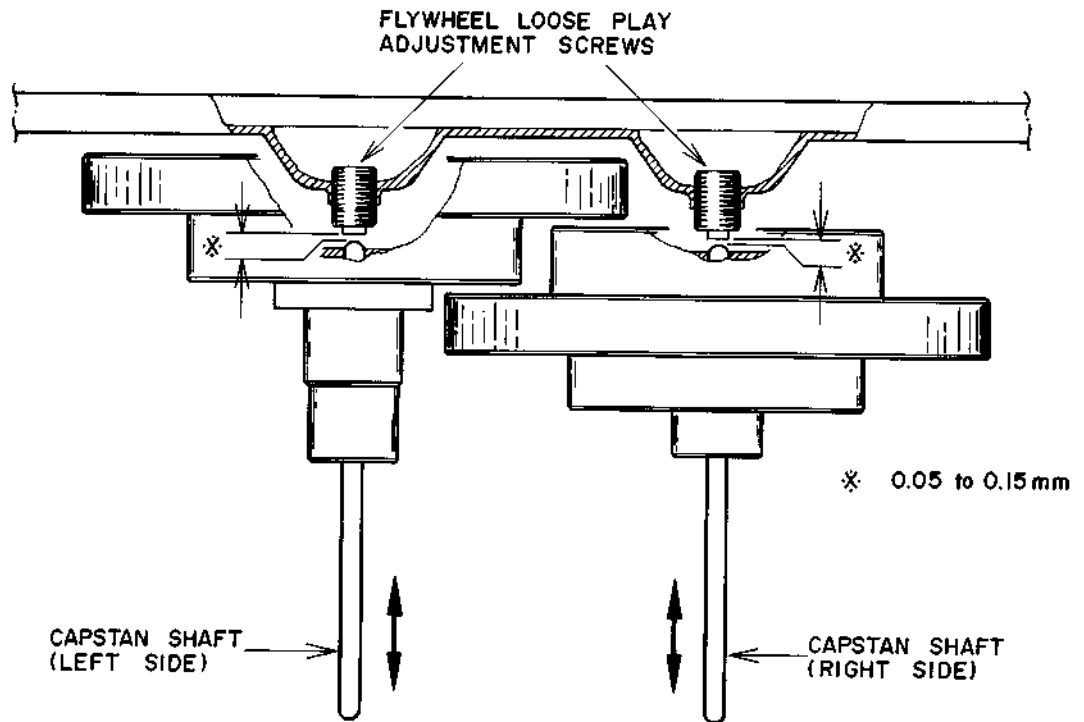

Fig. 8

1. FLYWHEEL LOOSE PLAY ADJUSTMENT (Refer to Fig. 8)

Adjust by turning flywheel loose play adjustment screws to obtain 0.05 to 0.15 mm of loose play when the capstan shaft is moved as indicated by the arrow mark.

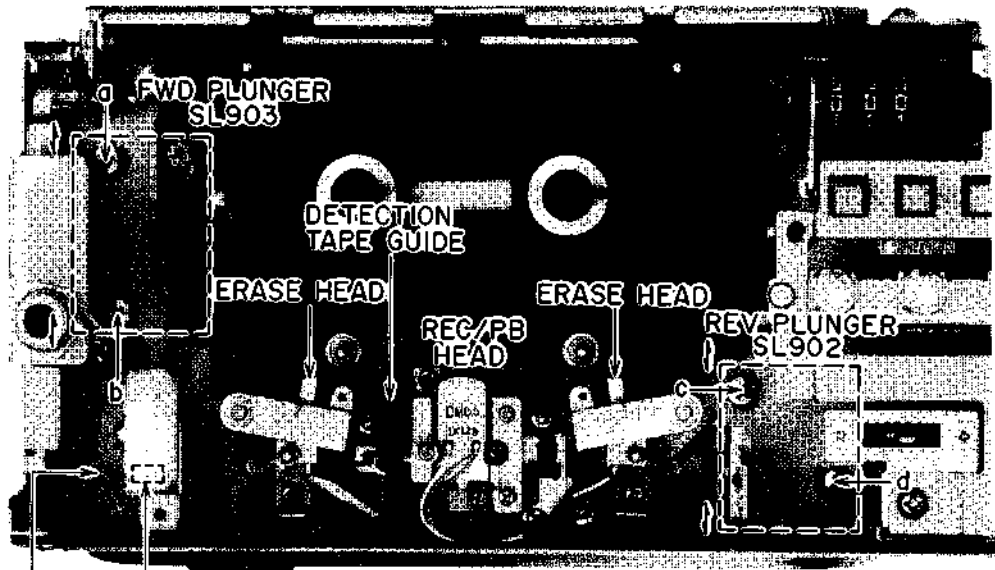

Fig. 9

CAPSTAN MOTOR
TAPE SPEED ADJ VOLUME

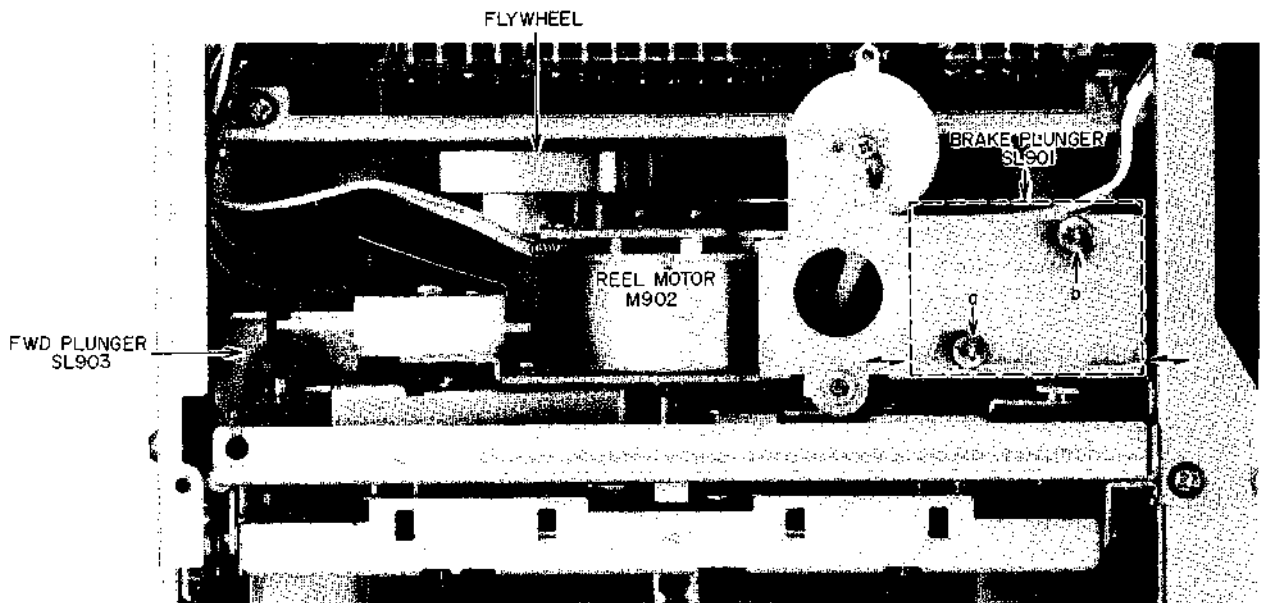

Fig. 10

2. PLUNGER POSITION ADJUSTMENT

- 1) Forward Plunger Adjustment (Refer to Figs. 9, 11)
Set the AKAI Head Projection Gauge.
Adjust the screws (a) and (b) so that when FWD PAUSE mode is engaged, the Head Projection Gauge indicates to $2.7 \text{ mm} \pm 0.1 \text{ mm}$.
- 2) Brake Plunger Adjustment (Refer to Figs. 10, 11)
Set the AKAI Head Projection Gauge.
Adjust the screws (a) and (b) so that when FWD

- PLAY mode is engaged, the Head Projection Gauge indicates to $3.4 \text{ mm} \pm 0.1 \text{ mm}$.
 - 3) Reverse Plunger Adjustment (Refer to Figs. 9, 11)
Set the AKAI Head Projection Gauge.
Adjust the screws (c) and (d) so that when REV PAUSE mode is engaged, the Head Projection Gauge indicates to $2.5 \text{ mm} \pm 0.1 \text{ mm}$.
- NOTE:** This adjustment mode is order of numbers.

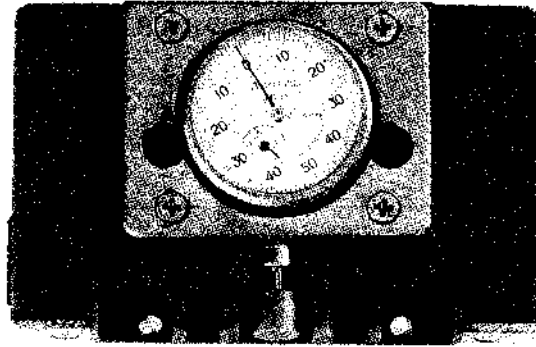

Fig. 11 AKAI Head Projection Gauge

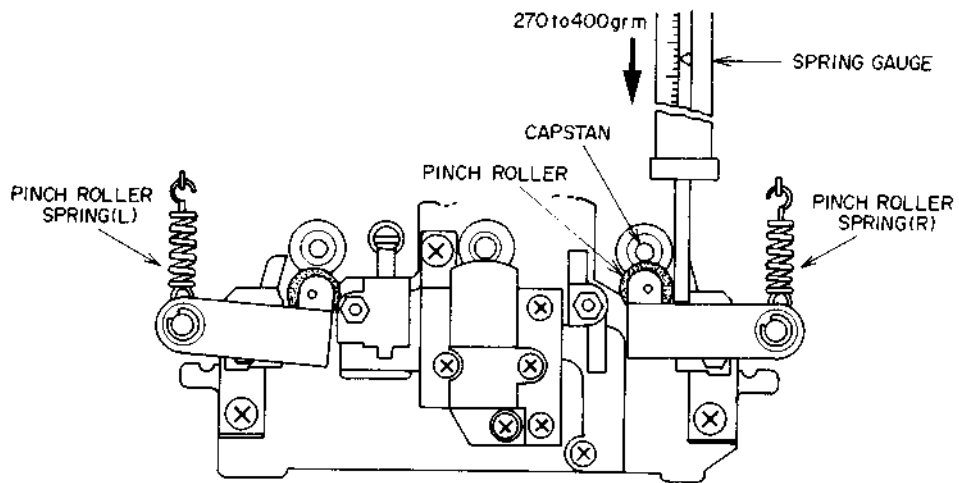

Fig. 12

3. PINCH ROLLER PRESSURE MEASUREMENT (Refer to Fig. 12)

Put in FWD PLAY mode. Push pinch roller arm down with the spring gauge push the pinch roller 1 ~ 2 mm from the capstan and release slowly.

Read the spring gauge at the moment the pinch roller touches the capstan and begins to rotate.

Specified contact pressure measurement of 270 to 400 gm.

If there is no measurement obtained, replace the pinch roller spring. Do the same for the reverse side.

4. WINDING TORQUE MEASUREMENT IN EACH MODE

Insert cassette torque meter and measure in each mode.

For fast forward and rewind measure at the end of the tape when the tape has stopped running.

Forward, Reverse: 30 to 55 g-cm

Fast Forward, Rewind: 75 to 130 g-cm

5. TAPE SPEED ADJUSTMENT (Refer to Fig. 9)

Connect a frequency counter to line output terminals.

Playback a 1,000 Hz pre-recorded test tape and adjust tape speed adjustment volume to obtain a tape speed of 995 Hz \pm 5 Hz.

VII. HEAD ADJUSTMENT

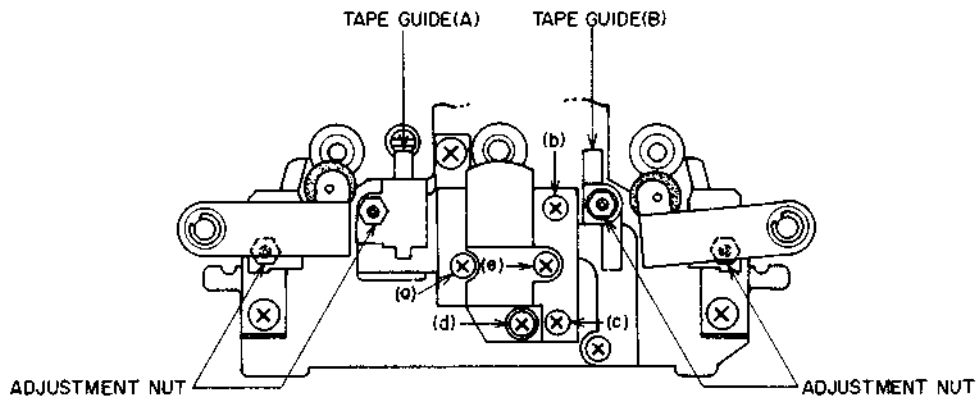

Fig. 13

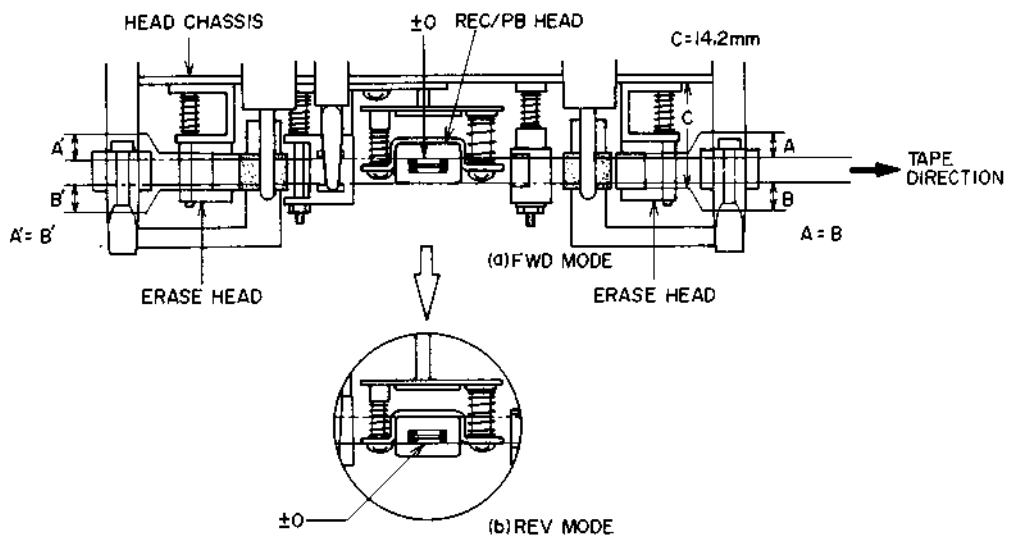

Fig. 14

1. ERASE HEAD HEIGHT ADJUSTMENT

(Refer to Figs. 13 to 15)

Usually this adjustment is not carried out. If adjustment is necessitated by head change for example, proceed as follows:

Adjust by turning the adjustment nut until the height, taken from the surface of the Head Chassis to the lower tip of the Erase Head Core (Fig. 14 C) is 14.2 mm.



Fig. 15

2. TAPE GUIDE HEIGHT ADJUSTMENT

(Refer to Figs. 13 to 15)

- 1) When using an ordinary cassette, the tape guides and heads, etc. are not visible. As shown in Fig. 15 use a cassette tape from which part of the cassette case has been cut out and a mirror installed easy visibility of the head area when making tape guide height adjustment.
- 2) The adjustment to Tape Guides (A) and (B) are carried out with the Erase Head at the standard height. Put into the FWD mode and adjust Tape Guide (A). Make the width of the sections (A and B in Fig. 14) protruding from both ends of the tape of the left side Erase Head the same. Next in the REV mode adjust Tape Guide (B) until A and B in Fig. 14 are the same. Finally, in either FWD or REV modes. Check that the tape is running smoothly without catching on the tape guides.

3. REC/PB HEAD HEIGHT ADJUSTMENT

(Refer to Figs. 13 to 15)

Playback the Head Height Adjustment Tape (4 Track 1,000 Hz) in the Reverse Play Mode and adjust the screws (a) (b) and (c) until the output level of both channels reaches maximum.

Next put in the Forward Mode and adjust the screws (d) and (e) so that output level reaches maximum same as above.

4. REC/PB HEAD AZIMUTH ADJUSTMENT

(Refer to Fig. 13)

- 1) Playback the azimuth adjustment tape (10 kHz) in the REV PLAY mode and adjust screws (a), (b), (c) until the output level of both channels reaches maximum (the AC voltmeter registers maximum).
- 2) Put in reverse mode and check that the output level is the same as in the forward mode. If different, adjust with screws (a), (b), (c) until the level is the same in both modes.
- 3) After adjustment, check both the head height and the azimuth.

NOTES:

1. Be sure to clean the heads prior to head adjustment.
2. Be careful not to use a magnetized driver or other magnetized tools in the vicinity of the heads.
3. Be sure to demagnetize the heads with a Head Demagnetizer before and after head adjustment.

VIII. ELECTRICAL ADJUSTMENT

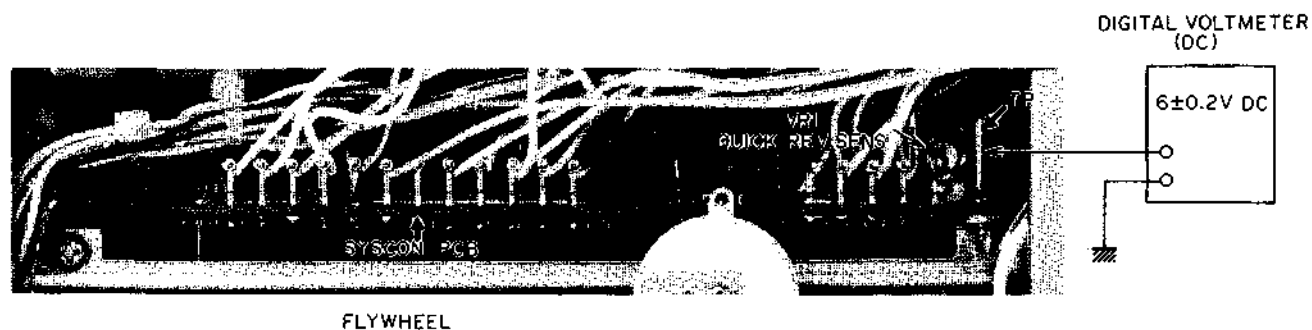

Fig. 16 SYSCON PCB T2041B503A

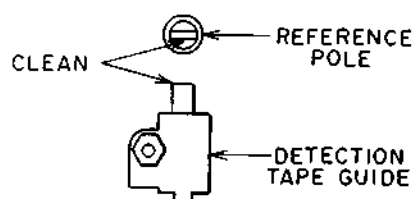

Fig. 17

1. QUICK REVERSE SENSITIVITY ADJUSTMENT

- 1) Make a tapeless cassette pack by removing the tape from the white colored test tape.
- 2) Connect the Digital Voltmeter between the TP and earth.
- 3) Using the tapeless cassette pack, adjust VR1 so that the Digital Voltmeter readings $6V \pm 0.2VDC$ at FWD play mode.

NOTE: Clean the Reference Pole and the Detection Tape Guide, before this adjustment. (Fig. 17)

2. AMPLIFIER ADJUSTMENT

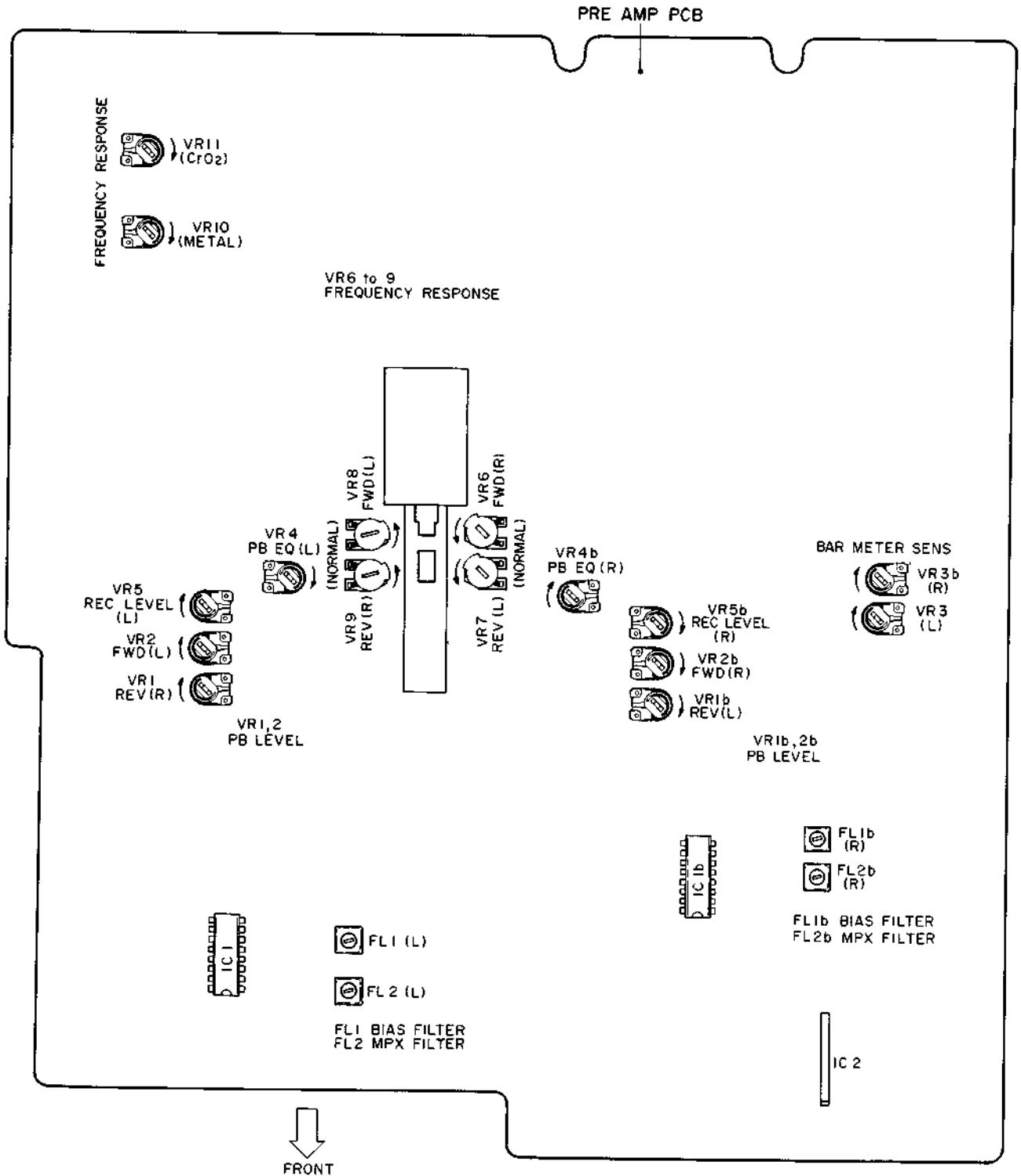

Fig. 18 Amplifier Adjustment (CS-F36R)

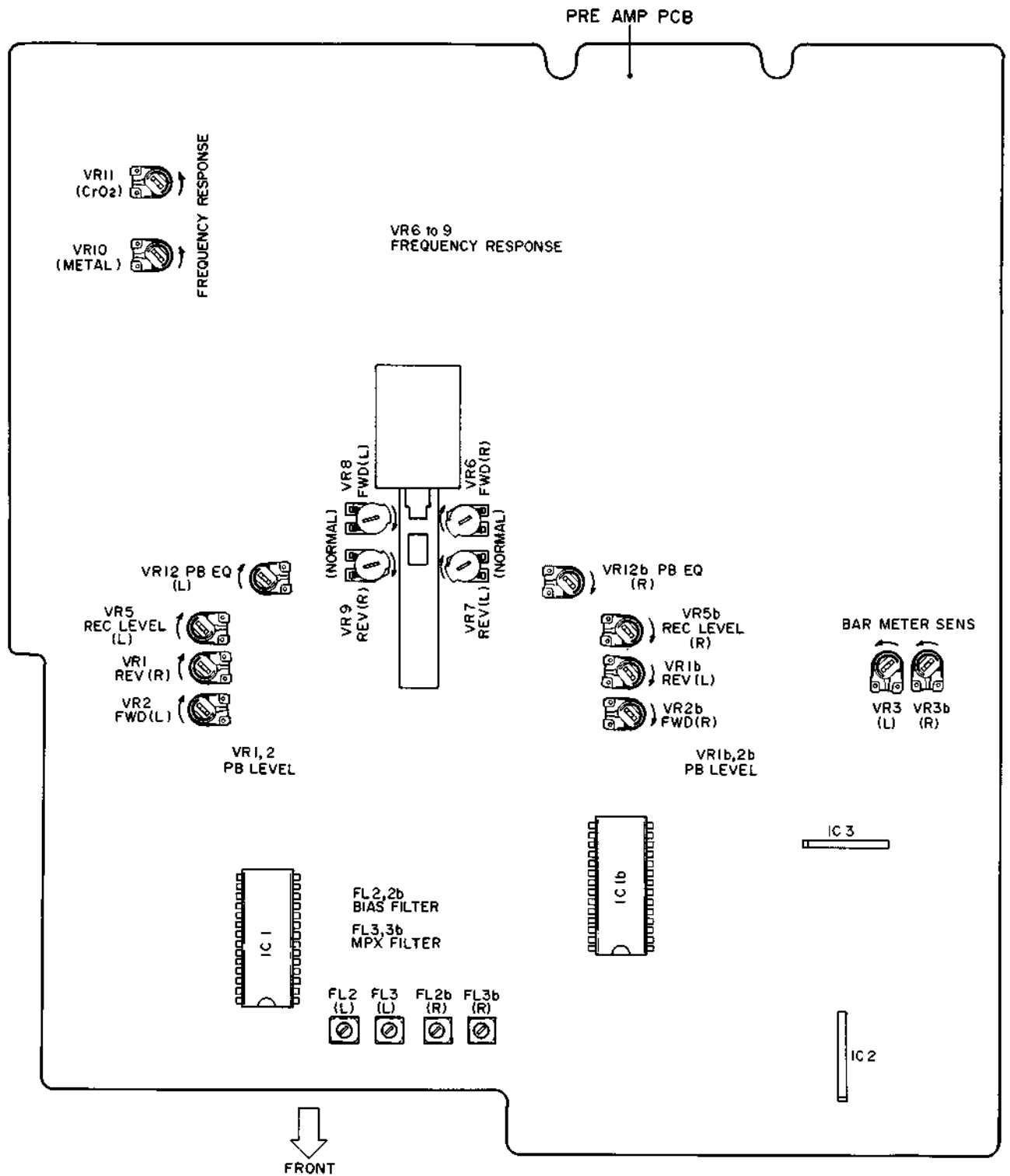

Fig. 19 Amplifier Adjustment (CS-F39R)

Step	Adjustment Item	Test Tape Supply Signal	Mode	Adjustment Point	Result	Remarks
1	FWD Playback Level	333 Hz 0VU Test Tape (TF-101CL)	FWD PB	VR2	-5.5 ± 0.2 dBm (410 mV)	
2	REV Playback Level	333 Hz 0VU Test Tape (TF-101CL)	REV PB	VR1	-5.5 ± 0.2 dBm (410 mV)	
3	PB EQ	10,000 Hz Test Tape (TF-106CH)	FWD-REV/ PB	VR4 (CS-F36R) VR12 (CS-F39R)	-22.5 ± 1.5 dBm	
4	Bar Meter Sensitivity	1,000 Hz -5.5 dBm from oscillator	REC	VR3	0VU indication	
5	Normal Position Frequency Response (FWD)	Normal Blank Tape 1,000 Hz, 10,000 Hz -25.5 dBm recording	FWD-REC/ PB	VR6 (R) VR8 (L)	1,000 Hz to 10,000 Hz flat response	
6	Normal Position Frequency Response (REV)	Normal Blank Tape 1,000 Hz, 10,000 Hz -25.5 dBm recording	REV-REC/ PB	VR7 (L) VR9 (R)	1,000 Hz to 10,000 Hz flat response	
7	CrO ₂ Position Frequency Response	CrO ₂ Blank Tape 1,000 Hz, 10,000 Hz -25.5 dBm Recording	FWD/ REV-REC/ PB	VR11	1,000 Hz to 10,000 Hz flat response	
8	Metal Position Frequency Response	Metal Blank Tape 1,000 Hz, 10,000 Hz -25.5 dBm recording	FWD/ REV-REC/ PB	VR10	1,000 Hz to 10,000 Hz flat response	
9	Recording Level	Normal Blank Tape 1,000 Hz -5.5 dBm recording	FWD/ REV-REC/ PB	VR5	-5.5 ± 0.3 dBm (410 mV)	
10	FWD Distortion Factor Confirmation	1,000 Hz -5.5 dBm recording	FWD-REC/ PB		Metal $< 0.7\%$	NOTE 5
11	REV Distortion Factor Confirmation	1,000 Hz -5.5 dBm recording	REV-REC/ PB		Metal $< 0.7\%$	NOTE 5
12	Bias Filter	No Signal Input	REC	FL1 (CS-F36R) FL2 (CS-F39R)	Minimum Output	Set REC Volume to maximum NOTE 6
13	MPX Filter	19 kHz from Oscillator	REC	FL2 (CS-F36R) FL3 (CS-F39R)	Minimum Output	Filter ON Position NOTE 6, 7.

-
- NOTES:**
1. Output Level Control should be at maximum.
 2. Because each of these adjustments is vital to perfect Dolby NR circuit operation, ensure that they are carried out with as few errors as possible.
 3. Except for Step 13 set Dolby NR switch to OFF Position.
 4. Use the following cassette measuring tapes:

Normal Tape:	Maxell UD	C-60
CrO ₂ Tape:	TDK SA	C-60
Metal Tape:	TDK MA-C	C-60
 5. If it does not comply with the specifications, repeat Steps 5 to 9 and readjust.
 6. Unless the core is moved unintentionally this adjustment is not necessary.
 7. Adjust the oscillator's frequency to give a frequency counter reading of 19.00 kHz.

IX. DC RESISTANCE OF VARIOUS COILS

Description	Name	DC Resistance
REC/PB Head	RP-5042-CM-0510	300 ohms ± 20%
Erase Head	HF213131	3.2 ohms
Plunger Solenoid	1240PLT	90 ohms ± 10%

X. CLASSIFICATION OF VARIOUS P.C BOARDS

1. P.C BOARD TITLES AND IDENTIFICATION NUMBERS

1) Model CS-F36R

P.C Board Title	P.C Board Number	Remarks
Pre Amp P.C Board	T2042A501A	
LED P.C Board	T2042A501B	
Volume P.C Board	T2042A501C	
Volume P.C Board	T2042A501I	
Reverse Selector P.C Board	T2042A501D	
Detector P.C Board	T2042A501E	
Tape Selector P.C Board	T2042A501F	
Dolby Switch P.C Board	T2042A501G	
Remote Control P.C Board	T2042A501H	
Operation P.C Board	T2042A501J	
Sys Con P.C Board	T2041B503A	
Power Supply P.C Board	T2022B5160	U
Power Supply P.C Board	T2022B5170	J
Power Supply P.C Board	T2022B5180	C, A
Power Supply P.C Board	T2022B5190	E, V, B, S
Filter P.C Board	CL-5026	
Meter P.C Board	A2013C5030	

2) Model CS-F39R

P.C Board Title	P.C Board Number	Remarks
Pre Amp P.C Board	T2041A501A	
LED P.C Board	T2041A501B	
Volume P.C Board	T2041A501C	
Volume P.C Board	T2041A501I	
Reverse Selector P.C Board	T2041A501D	
Detector P.C Board	T2041A501E	
Tape Selector P.C Board	T2041A501F	
Dolby Switch P.C Board	T2041A501G	
Remote Control P.C Board	T2041A501H	
Operation P.C Board	T2041A501J	
Syscon P.C Board	T2041B503A	
Memory SW P.C Board	T2041B503B	
Power Supply P.C Board	T2022B5160	U
Power Supply P.C Board	T2022B5170	J
Power Supply P.C Board	T2022B5180	C, A
Power Supply P.C Board	T2022B5190	E, V, B, S
Filter P.C Board	CL-5026	
Meter P.C Board	A2013C5030	

2. COMPOSITION OF VARIOUS P.C BOARDS

1) PRE AMP P.C BOARD T2042A501A (3ED) VOLUME P.C BOARD T2042A501C/T2042A501I TAPE SELECTOR P.C BOARD T2042A501F (Model CS-F36R)

LOCATION OF COMPONENTS		TERMINAL NO.
TR1, 2	-----	C3
TR3	-----	B3
TR4	-----	B4
TR5	-----	A2
TR6, 7	-----	C1
TR8, 9	-----	D1
TR10	-----	D2
TR12	-----	B4
TR13 to 16	-----	C4
TR17 to 18	-----	B4
TR19	-----	C4
TR20	-----	D2
TR21 to 23	-----	D3
TR24	-----	B4
TR26	-----	B4
TR27 to 29	-----	D2
TR30, 31	-----	B1
TR32, 33	-----	D3
TR34, 35	-----	D4
TR37 to 42	-----	D4
TR18, 26	-----	C2
TR38, 48	-----	B2
TR68, 78	-----	C1
TR88, 98	-----	D1
TR108	-----	D2
TR128	-----	B1
TR138	-----	C2
TR148 to 168	-----	C1
TR178, 188	-----	B1
TR198	-----	C1
IC1	-----	A4
IC1B	-----	B2
IC2	-----	A1

TR1, 4	2SD1012-V (F, G, H)
TR2, 3	2SC1312S (G, H)
TR5	2SC2274K (E, F)
TR6, 7, 13 to 20, 22, 23, 29	2SC2603 (E, F)
31, to 35, 37, 38, 42	2SD1012-V (G, H)
TR8	2SA1115 (E, F)
TR9, 10, 12, 21, 24, 26, 27	2SD612K (E, F)
TR28	2SD612K (E, F)
TR30	2SB774 (R, S)
TR38	2SC1061 (C, D)
TR40, 41	2SC2274K (E)

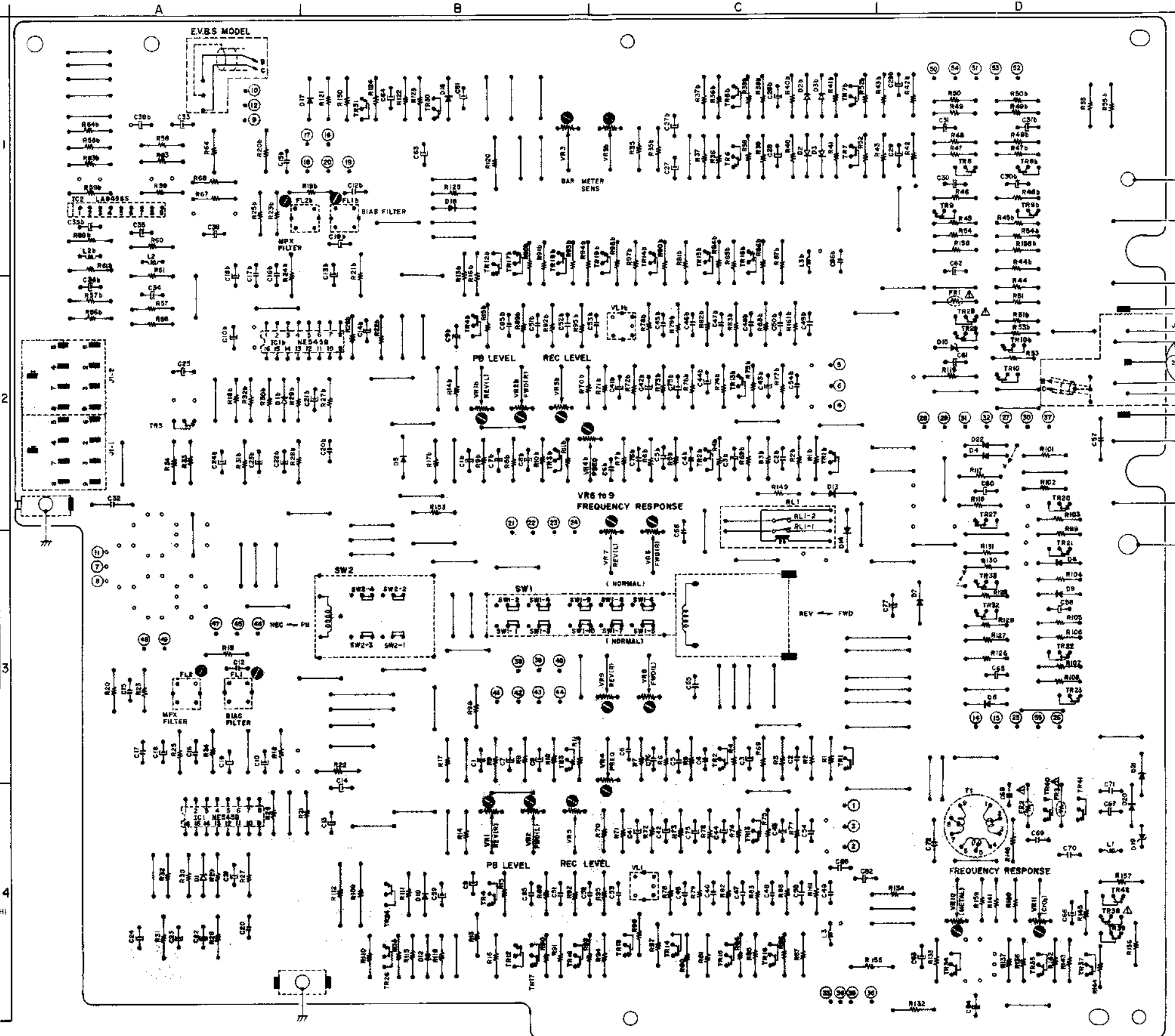
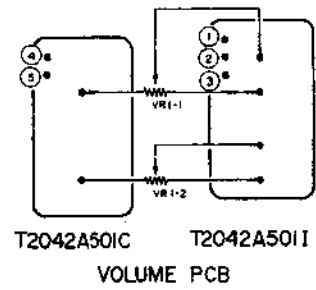

PRE AMP PCB T2042A501A

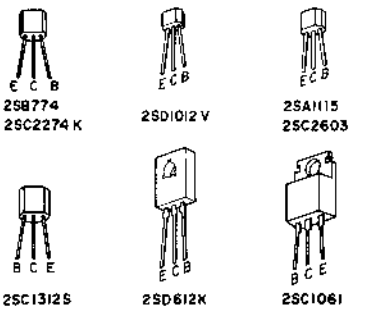

TAPE SELECTOR PCB T2042A501F

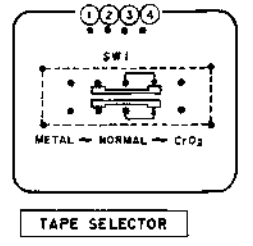

WARNING: INDICATES SAFETY CRITICAL COMPONENTS FOR CONTINUED SAFETY. REPLACE SAFETY CRITICAL COMPONENTS ONLY WITH MANUFACTURER'S RECOMMENDED PARTS.
 AVERTISSEMENT: IL INDIQUE LES COMPOSANTS CRITIQUES DE SÛRETÉ. POUR MAINTENIR LE Degré DE SÛRETÉ DE L'APPAREIL, NE REMPLACEZ LES COMPOSANTS DONNÉS QUE PAR LE FABRICANT. SEULS LES PIÈCES RECOMMANDÉES PAR LE FABRICANT.

2) SYSCON P.C BOARD T2041B503A, DETECTOR P.C BOARD T2024A501E FILTER P.C BOARD CL-5026 (2ED) (Model CS-F36R)

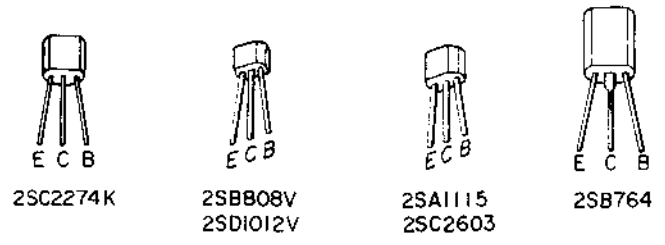

LOCATION OF COMPONENTS
TERMINAL NO.

TR1 to 5	A2	1 to 8	A1
TR7, 8	A2	9	B1
TR11, 12	A2	11 to 13	B1
TR13 to 16	B2	14 to 21	C1
TR17 to 20	A2	22 to 31	C2
TR21	A1	32 to 37	B2
TR22 to 24	C2	38 to 42	A1
TR25, 26	B2	43 to 51	C1
TR27	B1		
TR28	A1		
TR29, 30	B1		
TR31	C1		
TR33	A1		
TR34	C2		
TR36 to 38	B2		

TR1, 4, 8, 12, 17 to 20, 22 to 24, 27 to 31, 33, 34, 36, 37	2SC2603(F,G)
TR2	2SB764(E,F)
TR3, 7, 11	2SC2274K(E,F)
TR5, 21, 25, 26, 38	2SA1115(E, F)
TR13, 15	2SD1012V(F,G)
TR14, 16	2SB808-V(F,G)

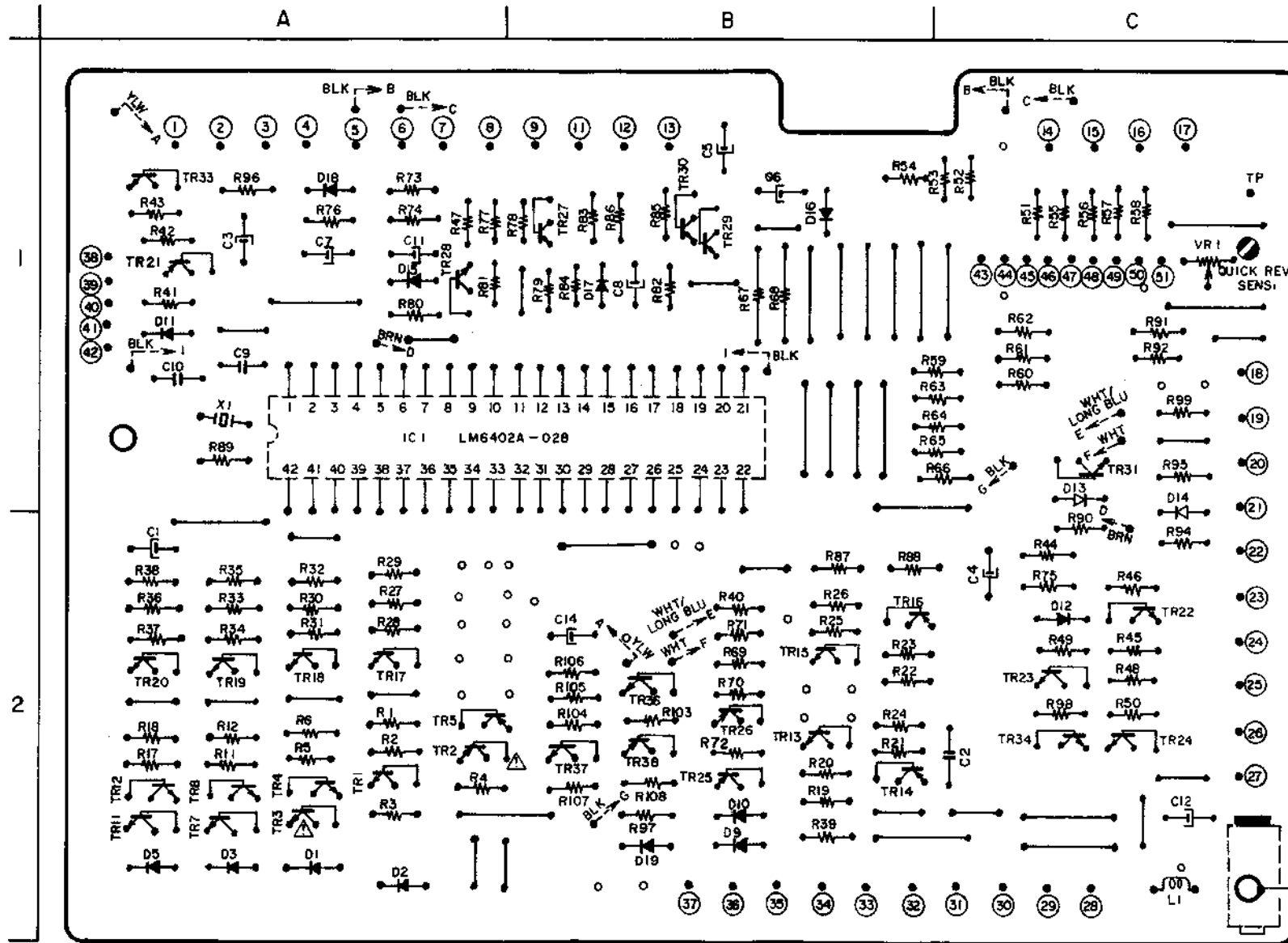

SYSCON PCB T2041B503A

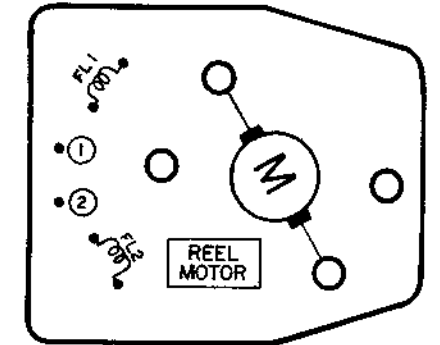

FILTER PCB CL-5026

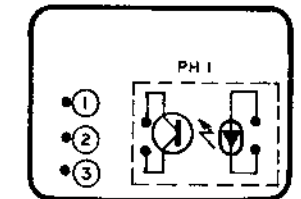

(CS-39R) DETECTOR PCB T2041A501E
(CS-36R) DETECTOR PCB T2024A501E

WARNING: Δ INDICATES SAFETY CRITICAL COMPONENTS. FOR CONTINUED SAFETY, REPLACE SAFETY CRITICAL COMPONENTS ONLY WITH MANUFACTURER'S RECOMMENDED PARTS.
AVERTISSEMENT: Δ IL INDIQUE LES COMPOSANTS CRITIQUES DE SÛRETÉ. POUR MAINTENIR LE DEGRÉ DE SÛRETÉ DE L'APPAREIL, NE REMPLACER LES COMPOSANTS DONT LE FONCTIONNEMENT EST CRITIQUE POUR LA SÛRETÉ QUE PAR DES PIÈCES RECOMMANDÉES PAR LE FABRICANT.

3) PRE AMP P.C BOARD T2041A501A (3ED) VOLUME P.C BOARD T2041A501C/T2041A501I TAPE SELECTOR P.C BOARD T2041A501F (Model CS-F39R)

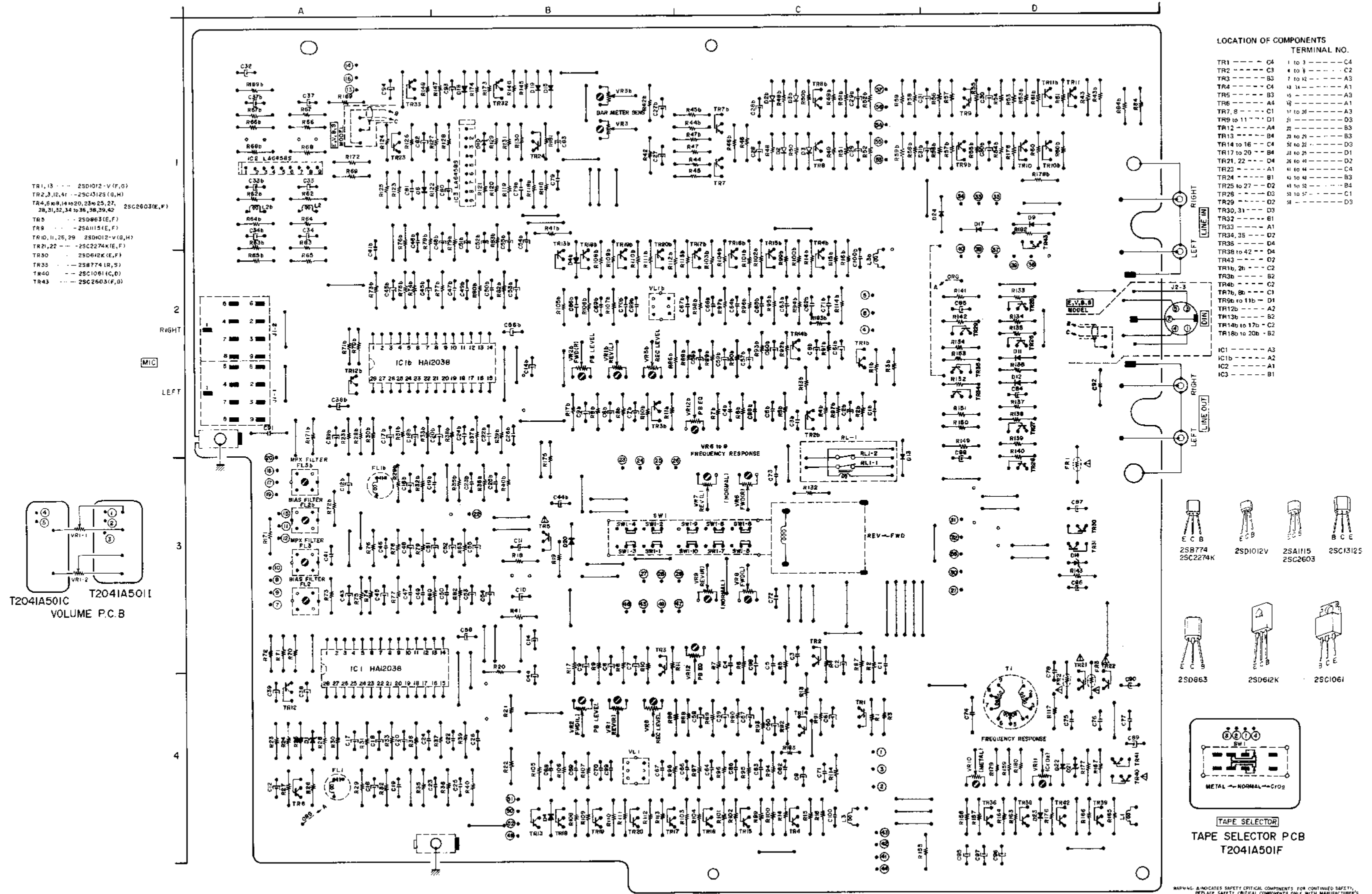

- TR1, 13 --- 2SD1012-V (F, G)
- TR2, 3, 10, 41 --- 2SC1312S (G, H)
- TR4, 6, 8, 14, 19, 20, 23, 25, 27, 28, 31, 32, 34 to 36, 38, 39, 42 --- 2SC2603(E, F)
- TR5 --- 2SD863 (E, F)
- TR9 --- 2SA1115 (E, F)
- TR10, 11, 26, 29 --- 2SD1012-V (G, H)
- TR21, 22 --- 2SC2274K(E, F)
- TR30 --- 2SD612K (E, F)
- TR33 --- 2SB774 (R, S)
- TR40 --- 2SC1061 (C, D)
- TR43 --- 2SC2603 (E, F)

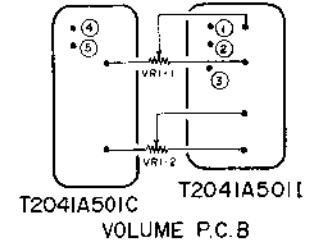

LOCATION OF COMPONENTS
TERMINAL NO.

TR1	---	C4	1 to 3	---	C4
TR2	---	C3	4 to 8	---	C2
TR3	---	B3	7 to 12	---	A3
TR4	---	C4	13 to 14	---	A1
TR5	---	B3	15	---	A3
TR6	---	A4	18	---	A1
TR7, 8	---	C1	17 to 20	---	A3
TR9 to 11	---	D1	21	---	D3
TR12	---	A4	22	---	B3
TR13	---	B4	23 to 25	---	B3
TR14 to 16	---	C4	26 to 28	---	D3
TR17 to 20	---	B4	29 to 32	---	D1
TR21, 22	---	D4	33 to 34	---	D2
TR23	---	A1	41 to 44	---	C4
TR24	---	B1	45 to 48	---	B4
TR25 to 27	---	D2	49 to 52	---	C1
TR28	---	D3	53 to 57	---	C1
TR29	---	D2	58	---	D3
TR30, 31	---	D3			
TR32	---	B1			
TR33	---	A1			
TR34, 35	---	D2			
TR36	---	D4			
TR38 to 42	---	A4			
TR43	---	D2			
TR1b, 2b	---	C2			
TR3b	---	B2			
TR4b	---	C2			
TR7b, 8b	---	C1			
TR9b to 11b	---	D1			
TR12b	---	A2			
TR13b	---	B2			
TR14b to 17b	---	C2			
TR18b to 20b	---	B2			
IC1	---	A3			
IC1b	---	A2			
IC2	---	A1			
IC3	---	B1			

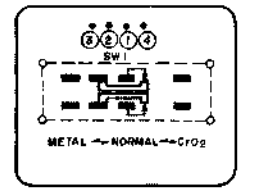
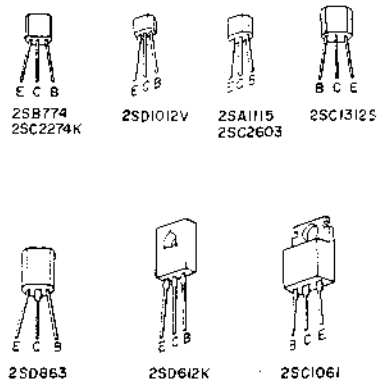

PRE AMP PCB T2041A501A

WARNING: INDICATES SAFETY CRITICAL COMPONENTS FOR CONTINUED SAFETY. REPLACE SAFETY CRITICAL COMPONENTS ONLY WITH MANUFACTURER'S RECOMMENDED PARTS.
AVERTISSEMENT: IL INDIQUE LES COMPOSANTS CRITIQUES DE SÛRETÉ. POUR MAINTENIR LE NIVEAU DE SÛRETÉ DE L'APPAREIL, NE REMPLACEZ LES COMPOSANTS QU'AVEC LE FONCTIONNEMENT EST CRITIQUE POUR LA SÛRETÉ, QUE PAR DES PIÈCES RECOMMANDÉES PAR LE FABRICANT.

4) SYSCON P.C BOARD T2041B503A DETECTOR P.C BOARD T2041A501E MEMORY SW P.C BOARD T2041B503B FILTER P.C BOARD CL-5026 (Model CS-F39R)

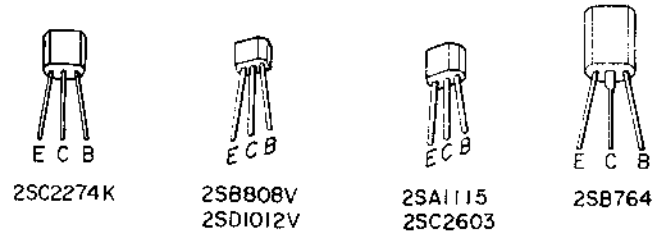

LOCATION OF COMPONENTS

TERMINAL NO.	LOCATION
1 to 8	A1
9	B1
10	B2
11 to 13	B1
14 to 21	C1
22 to 31	C2
32 to 37	B2
38 to 42	A1
43 to 51	C1
52 to 57	B2
58	B1
59	C1
60	A1
61	C2
62	A2
63 to 68	B2

TR1, 4, 8, 12, 17 to 20	
22 to 24, 27 to 31, 33 to 37	2SC2603 (F,G)
TR2	2SB764 (E,F)
TR3, 7, 11	2SC2274K (E,F)
TR5, 21, 25, 26, 38	2SA1115 (E, F)
TR13, 15	2SD1012V (F,G)
TR14, 16	2SB808 ~V (F,G)

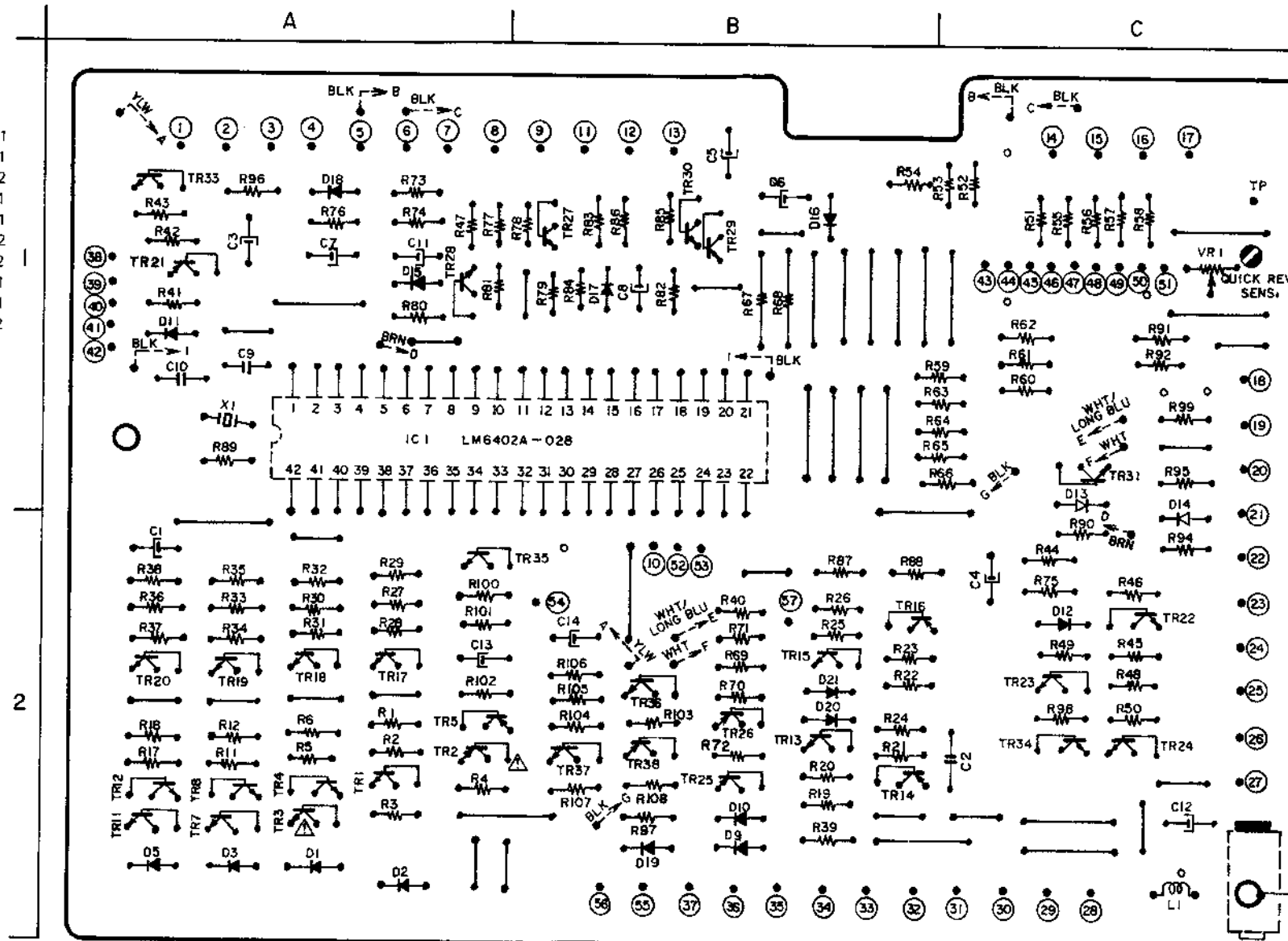

SYSCON PCB T2041B503A

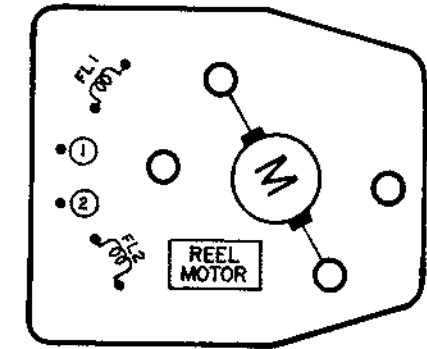

FILTER PCB CL-5026

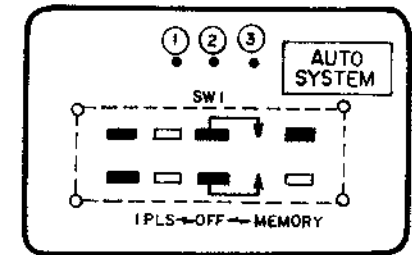

MEMORY SW PCB
T2041B503B

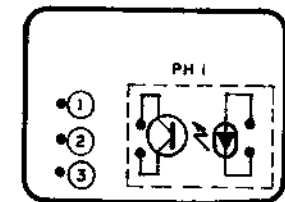

(CS-39R) DETECTOR PCB T2041A501E
(CS-36R) DETECTOR PCB T2041A501E

WARNING: INDICATES SAFETY CRITICAL COMPONENTS FOR CONTINUED SAFETY. REPLACE SAFETY CRITICAL COMPONENTS ONLY WITH MANUFACTURER'S RECOMMENDED PARTS.
AVERTISSEMENT: ΔIL INDIQU LES COMPOSANTS CRITIQUES DE SÛRETÉ. POUR MAINTENIR LE DEGRÉ DE SÛRETÉ DE L'APPAREIL, NE REMPLACER LES COMPOSANTS DONT LE FONCTIONNEMENT EST CRITIQUE POUR LA SÛRETÉ QUE PAR DES PIÈCES RECOMMANDÉES PAR LE FABRICANT.

5) DOLBY SWITCH P.C BOARD T2042A501G (Model CS-F36R)

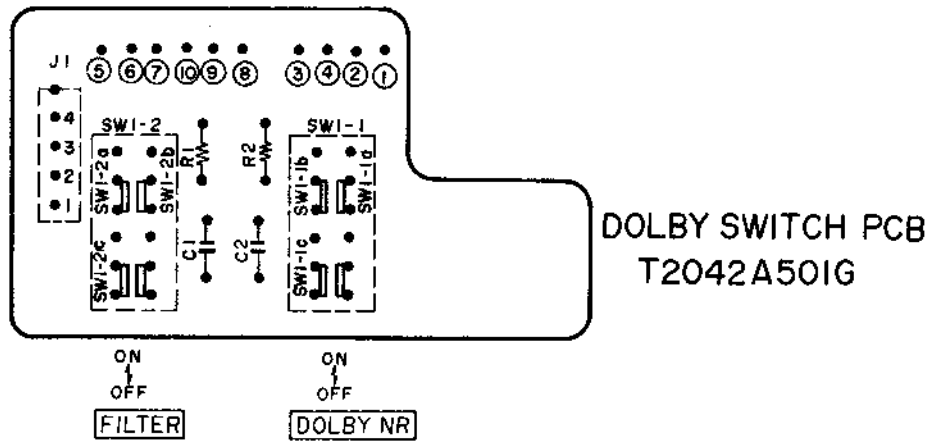

6) LED P.C BOARD T2042A501B (Model CS-F36R)

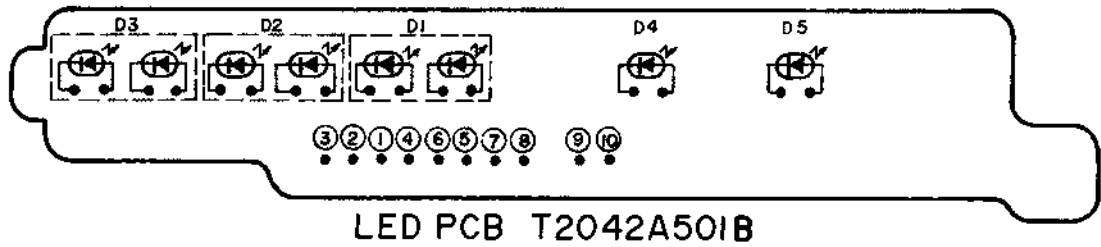

7) DOLBY SWITCH P.C BOARD T2041A501G (Model CS-F39R)

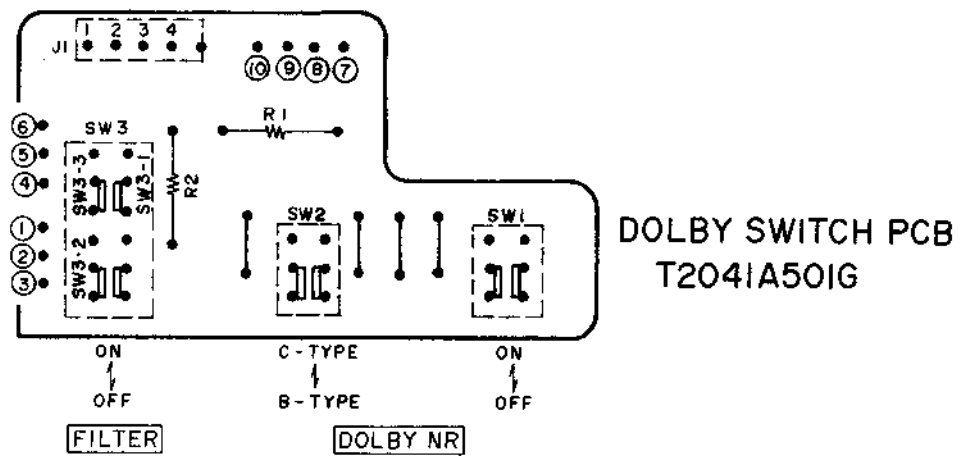

8) LED P.C BOARD T2041A501B (Model CS-F39R)

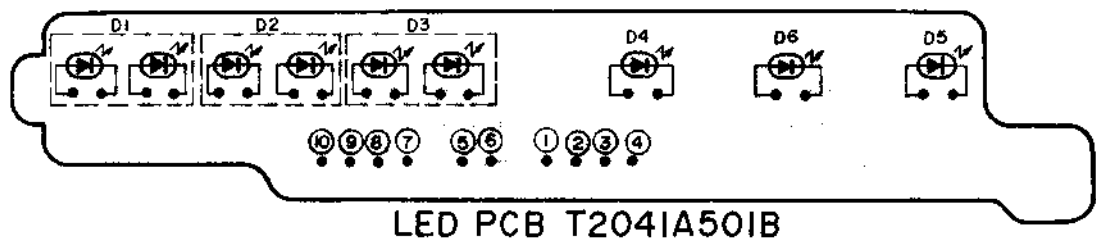

- 9) REVERSE SELECTOR P.C BOARD T2042A501D (Model CS-F36R)
 REVERSE SELECTOR P.C BOARD T2041A501D (Model CS-F39R)

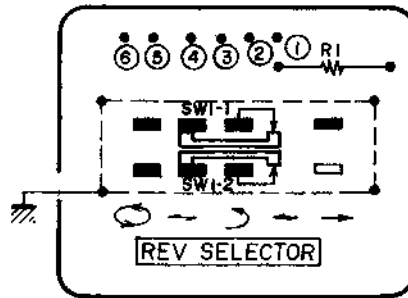

REVERSE SELECTOR PCB
 T2041A501D (CS-F39R)
 T2042A501D (CS-F36R)

- 10) OPERATION P.C BOARD T2042A501J (Model CS-F36R)
 OPERATION P.C BOARD T2041A501J (Model CS-F39R)

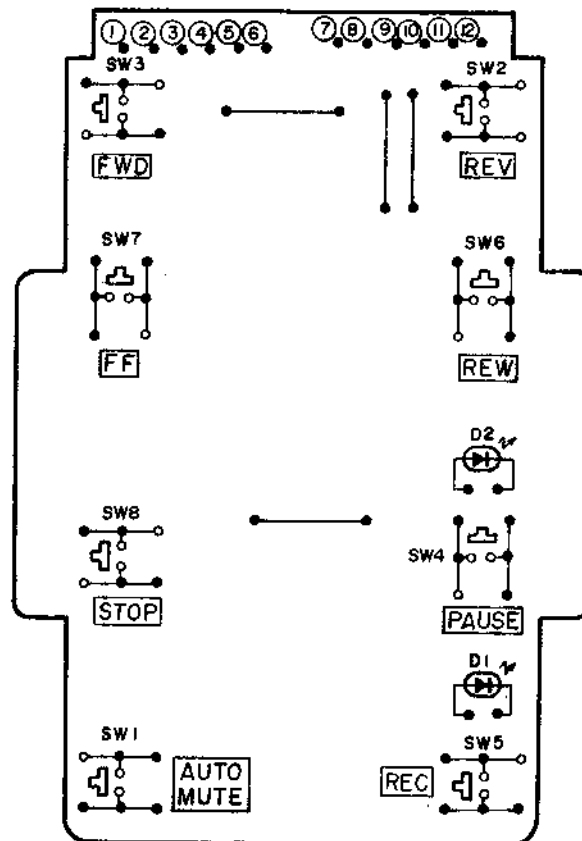

OPERATION PCB T2041A501J (CS-F39R)
 T2042A501J (CS-F36R)

11) REMOTE CONTROL P.C BOARD T2042A501H (Model CS-F36R)
 REMOTE CONTROL P.C BOARD T2041A501H (Model CS-F39R)

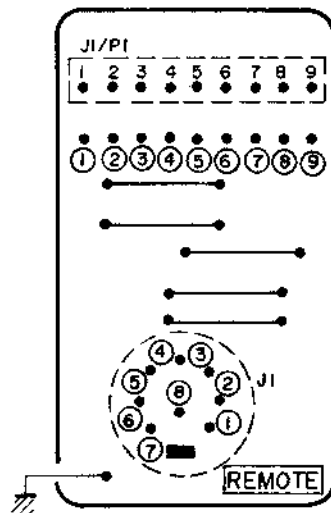

REMO CON PCB
 T2041A501H (CS-F39R)
 T2042A501H (CS-F36R)

12) METER P.C BOARD A2013C5030

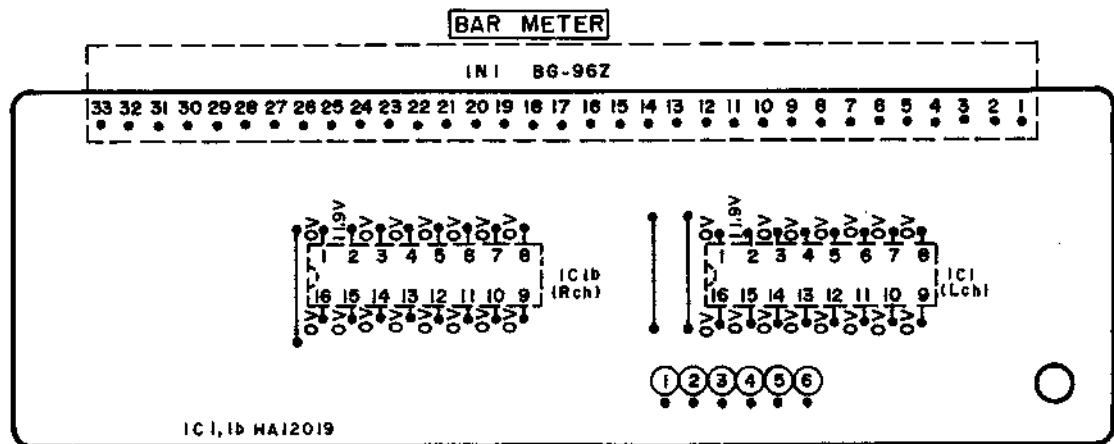

13) POWER SUPPLY P.C BOARD T2022B5160 (4ED) (U)

U MODEL

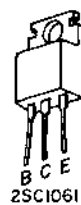
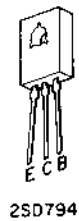
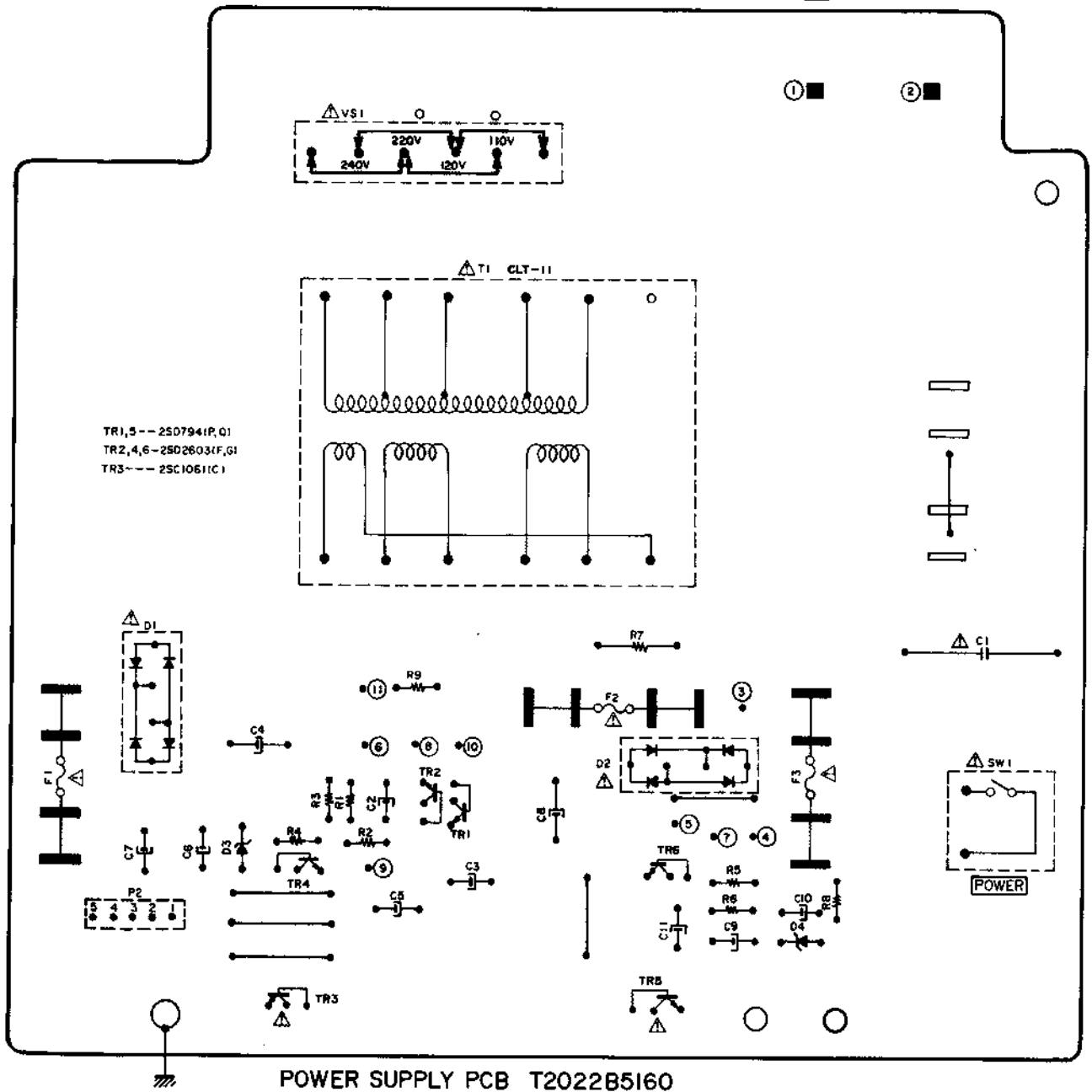

WARNING: Δ INDICATES SAFETY CRITICAL COMPONENTS. FOR CONTINUED SAFETY, REPLACE SAFETY CRITICAL COMPONENTS ONLY WITH MANUFACTURER'S RECOMMENDED PARTS.
 AVERTISSEMENT: Δ IL INDIQUE LES COMPOSANTS CRITIQUES DE SÛRETÉ. POUR MAINTENIR LE DEGRÉ DE SÛRETÉ DE L'APPAREIL, NE REMPLACER LES COMPOSANTS DONT LE FONCTIONNEMENT EST CRITIQUE POUR LA SÛRETÉ QUE PAR DES PIÈCES RECOMMANDÉES PAR LE FABRICANT.

14) POWER SUPPLY P.C BOARD T2022B5170 (4ED) (J)
 T2022B5180 (4ED) (C, A), T2022B5190 (4ED) (E, V, B, S)

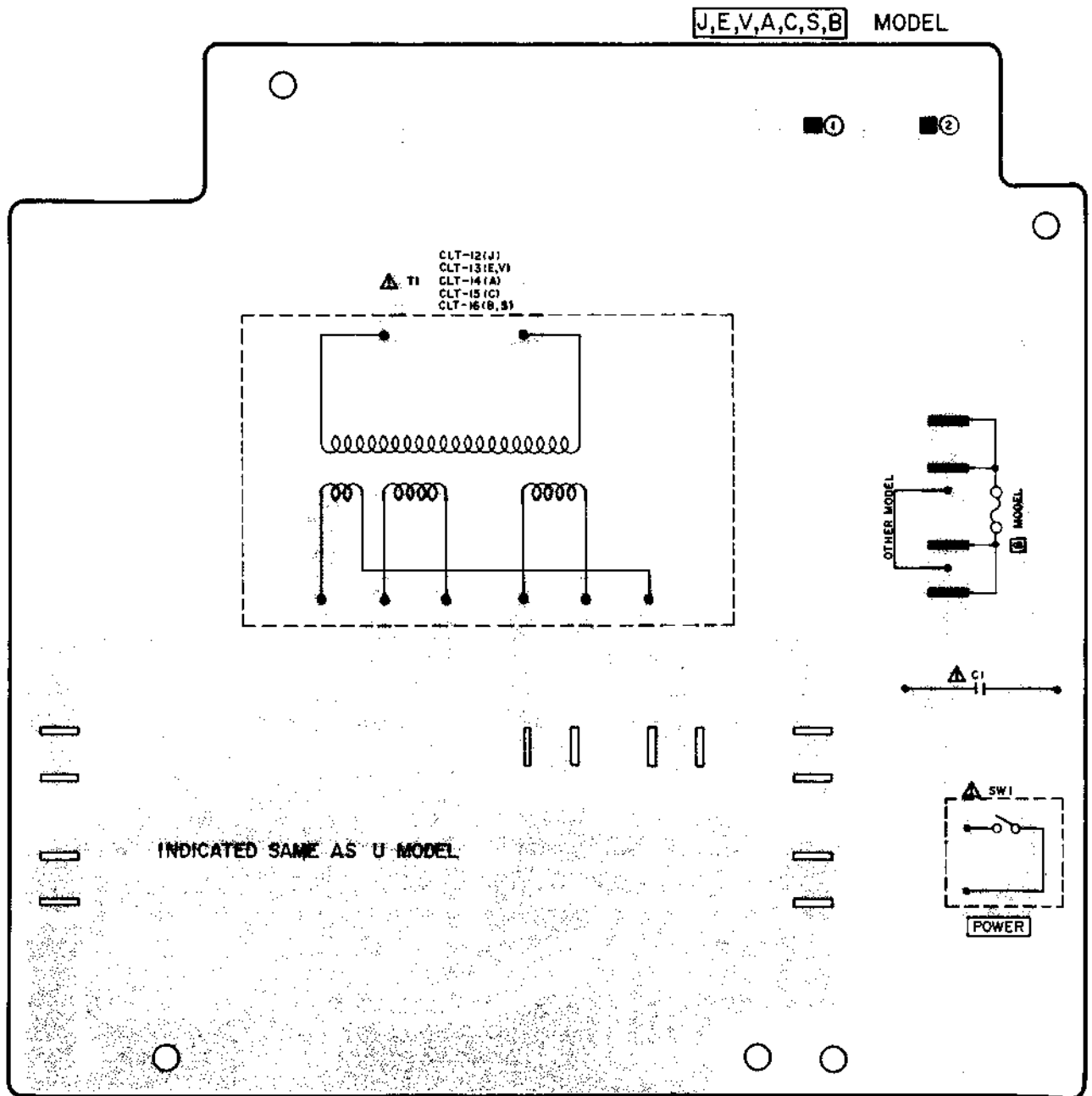

POWER SUPPLY PCB T2022B5170 (J)
 T2022B5180 (C, A)
 T2022B5190 (E, V, B, S)

WARNING: ⚠ INDICATES SAFETY CRITICAL COMPONENTS. FOR CONTINUED SAFETY, REPLACE SAFETY CRITICAL COMPONENTS ONLY WITH MANUFACTURER'S RECOMMENDED PARTS.
 AVERTISSEMENT: ⚠ IL INDIQUE LES COMPOSANTS CRITIQUES DE SÛRETÉ. POUR MAINTENIR LE DEGRÉ DE SÛRETÉ DE L'APPAREIL, NE REMPLACER LES COMPOSANTS DONT LE FONCTIONNEMENT EST CRITIQUE POUR LA SÛRETÉ QUE PAR DES PIÈCES RECOMMANDÉES PAR LE FABRICANT.

MEMO

MEMO

SECTION 3

PARTS LIST

TABLE OF CONTENTS

I. MODEL CS-F36R	
RECOMMENDED SPARE PARTS	39
1. HEAD BLOCK	40
2. REEL TABLE BLOCK	42
3. MECHA BLOCK	44
4. PRE AMP P.C BOARD BLOCK	46
5. SYS. CON. P.C BOARD BLOCK	47
6. POWER P.C BOARD BLOCK	47
7. METER P.C BOARD BLOCK	47
8. ASSEMBLY BLOCK	48
9. FINAL ASSEMBLY BLOCK	50
II. MODEL CS-F39R	
RECOMMENDED SPARE PARTS	51
1. HEAD BLOCK	52
2. REEL TABLE BLOCK	54
3. MECHA BLOCK	56
4. PRE AMP P.C BOARD BLOCK	58
5. SYS. CON. P.C BOARD BLOCK	59
6. POWER P.C BOARD BLOCK	59
7. METER P.C BOARD BLOCK	59
8. ASSEMBLY BLOCK	60
9. FINAL ASSEMBLY BLOCK	62
INDEX	
1. MODEL CS-F36R	63
2. MODEL CS-F39R	64

Resistor and Capacitor which is not listed in the parts list, please refer to COMMON LIST FOR SERVICE PARTS.

ATTENTION

1. When placing an order for parts, be sure to list the parts no., model no., and description. There are instances in which if any of this information is omitted, parts cannot be shipped or the wrong parts will be delivered.
2. Please be careful not to make a mistake in the parts no. If the parts no. is in error, a part different from the one ordered may be delivered.
3. Because parts numbers and parts and supply in the Preliminary Parts List may be partially changed, please use this parts list for all future reference.

HOW TO USE THIS PARTS LIST

1. This Parts List shows the parts that are considered necessary for repairs. Other parts, such as resistors and capacitors, are shown in the "Common List for Service Parts". Select and order such parts from the "Common List for Service Parts".
2. The Recommended Spare Parts shows those parts in the Parts List which are considered particularly important for service.
3. Parts not shown in the Parts List and "Common List for Service Parts" will not be supplied in principle.
4. How to read list

a) Mechanism Block

b) P.C Board Block

2. HEAD BASE BLOCK

REF. NO.	PARTS NO.	DESCRIPTION
2-1x	BH-T2023A320A	HEAD BASE BLOCK GX-F66R
2-2	HP-H2206A010A	HEAD R/P PR4-8FU C
2-3	ZS-477876	PAN20x03STL CMT
2-4	ZS-536488	BID20x08STL CMT
2-5	ZG-402895	CS ANGLE ADJUST SPRING

SP (Service Parts) Classification

A small "x" indicates the inability to show that particular part in the Photo or Illustration.

This number corresponds with the individual parts index number in that figure

This number corresponds with the Figure Number

6. SYS. CON. P.C BOARD BLOCK

REF. NO.	PARTS NO.	DESCRIPTION
6-1	BA-T2034A070A	PC SYS CON BLK GX-F44R
6-IC1	EI-324536	IC HD14049BP
6-IC2	EI-336801	IC MB8841-564M
6-IC3	EI-331661	IC SN7405N
6-IC4	EI-336725	IC M54527P
6-TR1to4	ET-200985	TR 2SC2603 F,G
6-TR5to28	ET-554657	TR 2SA733A P,Q
6-D1	ED-318292	D SILICON H 1S2473T-77 T26
6-D2to4	ED-308952	D GERMA V 1K34A-LR F07
6-D5to10	ED-318292	D SILICON H 1S2473T-77 T26
6-X1	EI-318384	OSC X'TAL NC-18C 3.579545MHZ

SP (Service Parts) Classification

This reference numbers corresponds with symbol numbers of Schematic Diagrams.

5. Both the kind of part and installation position can be determined by the Parts Number. To determine where a parts number is listed, utilize Parts Index at end of Parts List. It is necessary first of all to find the Parts Number. This can be accomplished by using the Reference Number listed at right of parts number in the Parts Index.

WARNING

X INDICATES SAFETY CRITICAL COMPONENTS. FOR CONTINUED SAFETY, REPLACE SAFETY CRITICAL COMPONENTS ONLY WITH MANUFACTURER'S RECOMMENDED PARTS.

AVERTISSEMENT

X IL INDIQUE LES COMPOSANTS CRITIQUES DE SURETE POUR MAINTENIR LE DEGRE DE SECURITE DE L'APPAREIL. NE REMPLACER LES COMPOSANTS DONT LE FONCTIONNEMENT EST CRITIQUE POUR LA SECURITE QUE PAR DES PIECES RECOMMANDEES PAR LE FABRICANT.

I. MODEL CS-F36R

RECOMMENDED SPARE PARTS

Because, if the parts listed below are on hand, almost any repair can be accomplished, we suggest that you stock these Recommended Spare Parts Items.

NO.	PARTS NO.	DESCRIPTION	NO.	PARTS NO.	DESCRIPTION
1	BH-T2042A130A	HEAD BLK CS-F36R	62	EO-311974	COIL OSC1 0322-1034-022 100 KHZ
2	BI-312117	REW IDLER ASSY	63	EO-321336	COIL VARI 1 FE002 10MH
3	BI-312118	TAKE UP IDLER ASSY	64	EP-318644	Δ SOLENOID 1240PLT 27V
4	BL-T2010D090A	PINCH ROLLER (L) BLK CS-M40R	65	EP-318645	Δ SOLENOID 1240PLT 27V
5	BL-T2010D100A	PINCH ROLLER (R) BLK CS-M40R	66	EP-318648	RELAY LEAD LAB2NS 2NO 6V
6	BM-T2022A080A	Δ MOTOR (PULLEY) BLK CS-F33R	67	ER-321251	Δ R CB H SNP FS RDS 1/2W 561J
7	BM-314843	Δ MOTOR EG-510ED-2F	68	ER-318647	Δ R FUSE ERD2FC F10 1/4W 4R7J
8	BM-328441	Δ MOTOR RF-510T (12620)	69	ER-200595	Δ R FUSE ERD2FC F10 1/4W 5R6J
9	BM-T2016A320A	Δ REEL MOTOR BLK (W/PULLEY) GX-F35	70	ER-328490	FILTER DB D07-001K 19KHZ
10	BR-328424	TAKE-UP REEL TABLE ASSY	71	ER-328491	FILTER DB D07-003K 100KHZ
11	BT-311464	Δ TRANS POWER CLT-11 (U)	72	ES-312234	Δ SW PUSH SDL-1P 01-1 E(U,E,B,S)
12	BT-311470	Δ TRANS POWER CLT-12 (J)	73	ES-312235	Δ SW PUSH SDL-1P 01-1 J (J)
13	BT-311488	Δ TRANS POWER CLT-13 (E,V)	74	ES-312238	Δ SW PUSH SDL-1P 01-1 UC (C,A)
14	BT-311475	Δ TRANS POWER CLT-14 (A)	75	ES-330521	SW LEAF BSW-47AB 01-1 NC
15	BT-311505	Δ TRANS POWER CLT-15 (C)	76	ES-330522	SW LEAF BSW-47AC 01-1 NC
16	BT-311494	Δ TRANS POWER CLT-16 (B,S)	77	ES-338170	SW PUSH ESB-62267 2 THROW
17	BZ-T2016A290A	DAMPER (A) ASSY GX-F35	78	ES-330463	SW SLIDE 00230593 2-02-03S
18	BZ-T2016A330A	DAMPER (B) ASSY GX-F35	79	ES-337322	SW SLIDE 00230699 2-02-03N
19	BZ-T2022A260A	DAMPER (C) ASSY CS-F33R	80	ES-311975	SW SOLENOID R8150050 27V 10-2W
20	BZ-T2041A100A	DETECTION TAPE GUIDE BLK CS-F39R	81	ES-328415	SW SOLENOID SWE018401 18V 04-2S
21	ED-309341	D GERMA H 1K34A	82	ES-336780	SW TACT KHH10902
22	ED-308952	D GERMA V 1K34A-LR F07	83	ET-311977	PHOTO SENSOR SPI-201
23	ED-337092	D LED GL-9HY4 YLW	84	ET-200558	TR 2SA1115 E,F
24	ED-337091	D LED LT9200N GRN	85	ET-318237	TR 2SB764 E,F
25	ED-337010	D LED SLF-201C GRN	86	ET-338081	TR 2SB774 R,S
26	ED-337014	D LED SR503D RED	87	ET-328438	TR 2SB808-V F,G
27	ED-337195	D LED SY403DA YLW	88	ET-402682	TR 2SC1061 C
28	ED-301911	D SILICON H DS448	89	ET-317919	TR 2SC1061 C,D
29	ED-330987	D SILICON RB152 200/1.5A	90	ET-603257	TR 2SC1312S G,H
30	ED-560913	D SILICON V 1S2473VE	91	ET-309353	TR 2SC2274 E,F
31	ED-306109	D SILICON W03B 100/1.0A	92	ET-310833	TR 2SC2274K E
32	ED-329449	D ZENER H HZ18 3	93	ET-200505	TR 2SC2603 E,F
33	ED-331198	D ZENER H HZ3 A1	94	ET-200985	TR 2SC2603 F,G
34	ED-319167	D ZENER H HZ6 C3	95	ET-328437	TR 2SD1012-V F,G
35	ED-318859	D ZENER H HZ9 C2	96	ET-319638	TR 2SD1012-V F,G,H
36	EF-668474	Δ FUSE SEMKO T 250V 0.40A (F3) (E,B,S,V)	97	ET-328868	TR 2SD1012-V G,H
37	EF-602550	Δ FUSE SEMKO T 250V 1.25A (F4) (B)	98	ET-310148	TR 2SD612K E,F
38	EF-602550	Δ FUSE SEMKO T 250V 1.25A (F2) (E,B,S,V)	99	ET-307439	TR 2SD794 P,Q
39	EF-601964	Δ FUSE SEMKO T 250V 1.60A (F1) (E,B,S,V)	100	EV-315542	R S-FIX H D8 3P 103
40	EF-309389	Δ FUSE TSC A 250V 0.40A (F3) (U,J)	101	EV-322415	R S-FIX H D8 3P 104
41	EF-306949	Δ FUSE TSC A 250V 1.25A (F2) (U,J)	102	EV-322411	R S-FIX H D8 3P 202
42	EF-311839	Δ FUSE TSC A 250V 1.6A (F1) (U,J)	103	EV-315753	R S-FIX H D8 3P 203
43	EF-308848	Δ FUSE TSC 125V 0.40A(F3)(C,A)	104	EV-322417	R S-FIX H D8 3P 303
44	EF-309392	Δ FUSE TSC 125V 1.25A(F2)(C,A)	105	EV-315540	R S-FIX H D8 3P 502
45	EF-308847	Δ FUSE TSC 125V 1.60A(F1)(C,A)	106	EV-336785	R S-FIX H TM8KV2-1S 3P 0.50W 104
46	EI-315799	IC HA12019	107	EV-522652	R S-FIX V V8K1-1 3P 105
47	EI-336761	IC LA6458S	108	EV-338033	VR SLIDE 100P1WV0A A104
48	EI-311710	IC LM6402A-028	109	EZ-328406	OSC CE CSB400A 0.4MHZ
49	EI-605013	IC NE545B	110	HE-325859	HEAD E HF213131 C
50	EJ-310567	Δ SOCKET INLET 0378PC-GS E 2P	111	HP-311634	HEAD R/P RP-5042-CM-0510 C
51	EJ-283140	Δ SOCKET SELECTER X-I7238 6P (U)	112	MB-314317	BELT CAPSTAN
52	EJ-331215	DIN J TCS1881-101 P 8P	113	MB-342028	BELT COUNTER
53	EJ-332437	JACK PLATE (E,B,S,V)	114	MC-342355	COUNTER ME360-152
54	EJ-332109	PHONE J HLJ0346-010 2x3P	115	MI-B601782	FLYWHEEL (A) PART
55	EJ-336886	PHONE J 3P HLJ0607-020 6.3 (P)	116	MI-B601783	FLYWHEEL (B) PART
56	EJ-336885	PHONE J 3P HLJ0607-023 6.3	117	MP-B342026	ROLLER PINCH PART
57	EJ-332435	PIN J P 4P (U,J,C,A)			
58	EM-332427	IND FL BG-96Z GRAPH			
59	EO-330239	COIL FIX 1 FL09H 390μH J			
60	EO-316140	COIL FIX 1 RX9P-562J 5.60MH J			
61	EO-669273	COIL FIX 2 FL5R200 18μH			

When ordering parts, please quote Parts Number, Description and Model Number.

HEAD BLOCK

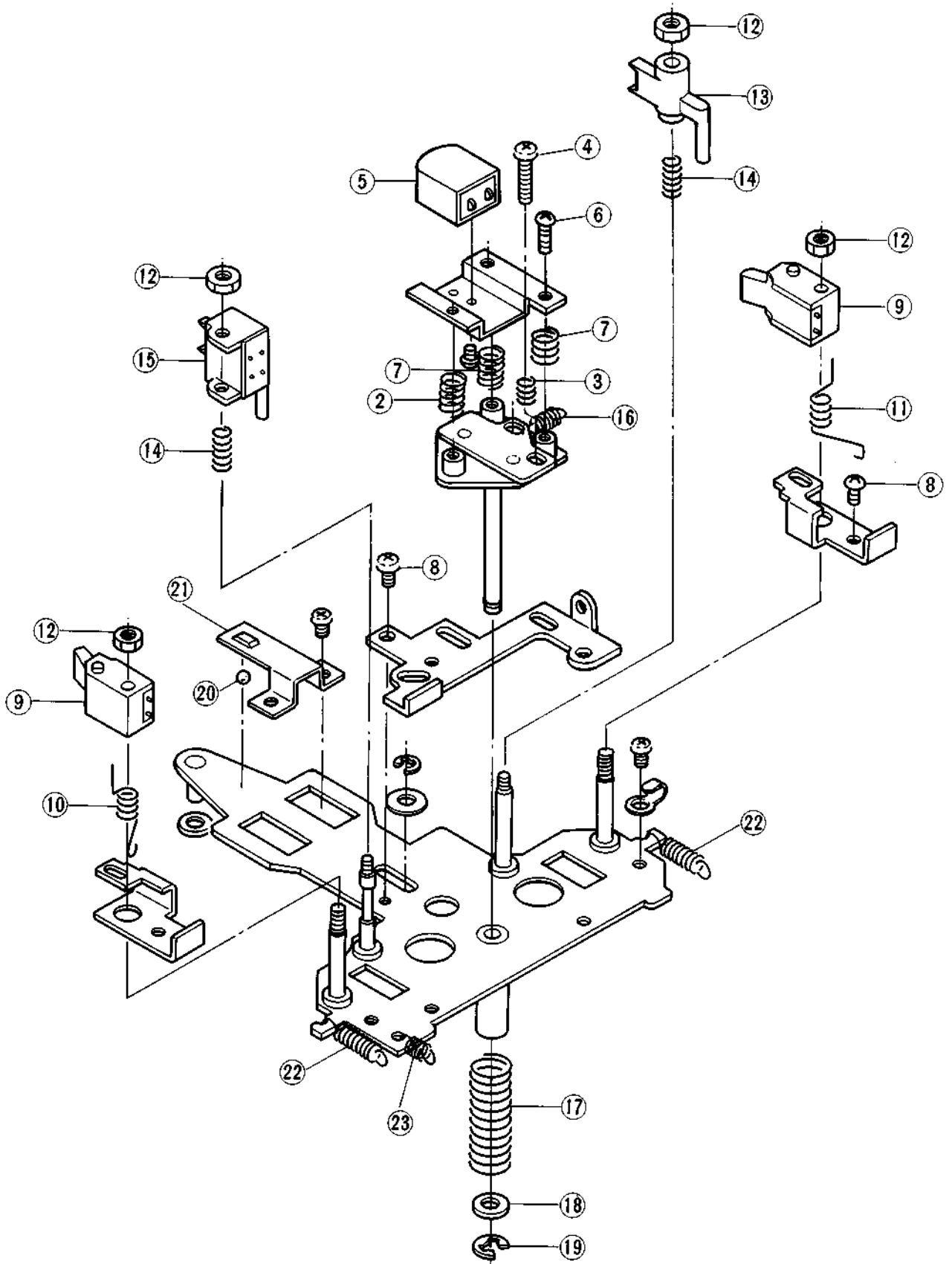

1. HEAD BLOCK

REF. NO.	PARTS NO.	DESCRIPTION
1-1x	BH-T2042A130A	HEAD BLK CS-F36R
1-2	ZG-369088	ANGLE ADJUST SPRING
1-3	ZG-402895	CS ANGLE ADJUST SPRING
1-4	ZS-465298	PAN23x10STL CMT
1-5	HP-311634	HEAD R/P RP-5042-CM-0510 C
1-6	ZS-608106	PAN20x06STL CMT
1-7	ZG-328305	ANGLE SPRING
1-8	ZS-592378	PAN26x03STL CMT
1-9	HE-325859	HEAD E HF213131 C
1-10	ZG-313316	ERASE HEAD SPRING (A)
1-11	ZG-313874	ERASE HEAD SPRING (B)
1-12	ZW-618884	N20STL CMT 1
1-13	HZ-313313	TAPE GUIDE
1-14	ZG-313314	ADJUST SPRING
1-15	BZ-T2041A100A	DETECTION TAPE GUIDE BLK CS-F39R
1-16	ZG-330078	SP T2-3.2/0.2-9.0 T2-038
1-17	ZG-313960	SP PUSH
1-18	ZW-556828	PW32x100x050STL CMT
1-19	ZW-270088	RING E 190SUP CMT
1-20	MV-357208	BALL200STL
1-21	MH-314340	HEAD HOLDER
1-22	ZG-312946	SP T1-3.2/0.29-16.0 T1-062
1-23	ZG-312921	SP T1-3.2/0.2-9.0 T1-038

REEL TABLE BLOCK

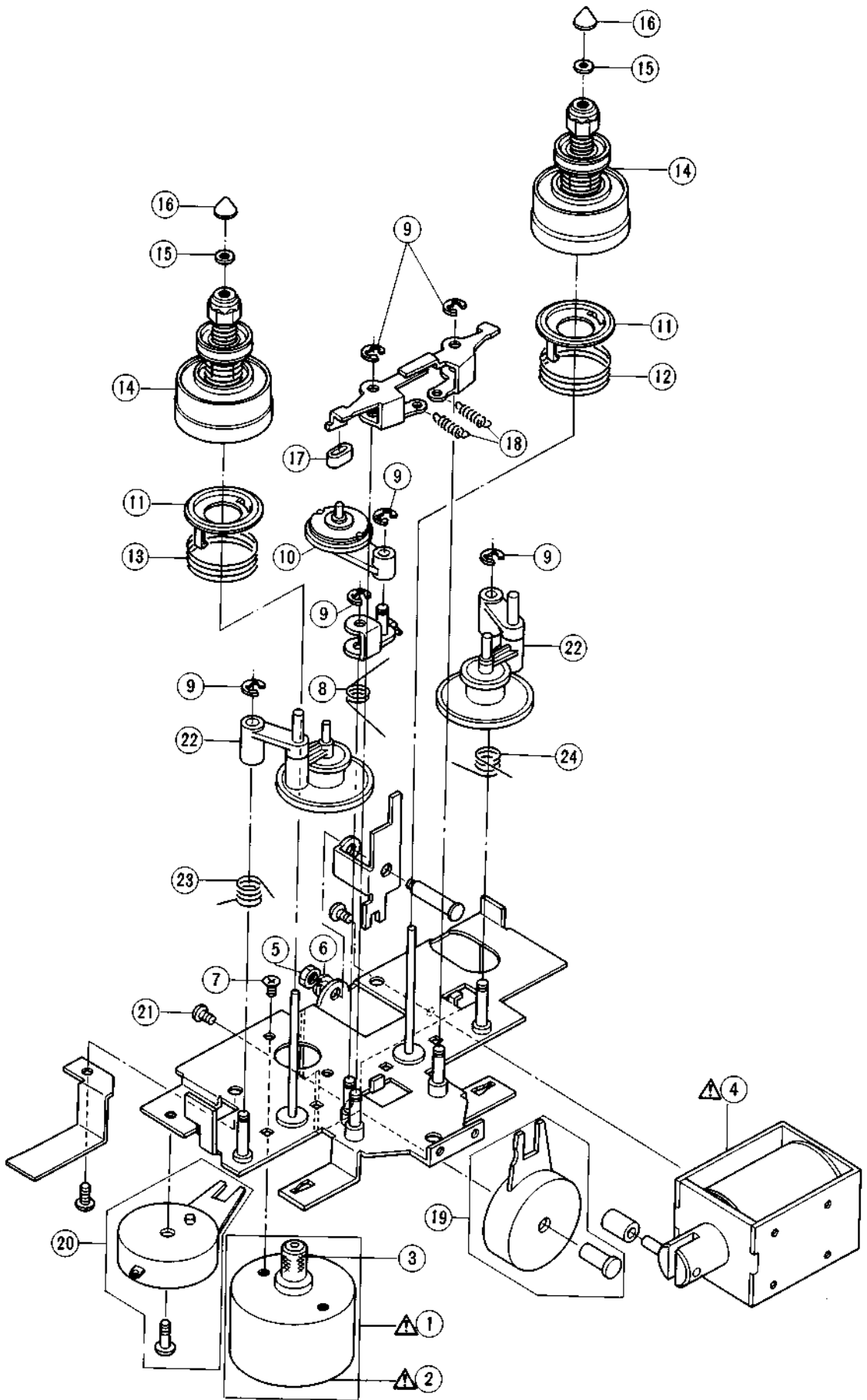

2. REEL TABLE BLOCK

REF. NO.	PARTS NO.	DESCRIPTION
REEL MOTOR BLOCK		
2-1	BM-T2016A320A	△ REEL MOTOR BLK (W/PULLEY) GX-F35
2-2	BM-328441	△ MOTOR RF-510T (12620)
2-3	MR-328360	REEL MOTOR PULLEY
PLUNGER ASSY		
2-4	EP-318645	△ SOLENOID 1240PLT 27V(SL901)
REEL TABLE BLOCK		
2-5	ZW-516993	N30STL CMT 1
2-6	ZW-273745	SW30
2-7	ZS-430413	CTS26×04STL CMT
2-8	ZG-314747	SP TORSION IDLER
2-9	ZW-270088	RING E 190SUP CMT
2-10	BI-312117	REW IDLER ASSY
2-11	TC-328365	BT DRUM
2-12	ZG-328366	BT SPRING
2-13	ZG-330049	SP PUSH BACK TENSION
2-14	BR-328424	TAKE-UP REEL TABLE ASSY
2-15	ZW-330073	PW21×040×020
2-16	MT-305793	REEL CAP
2-17	MB-282104	BRAKE RUBBER
2-18	ZG-321534	SP T2-3.2/0.29-12.5 T2-060
2-19	BZ-T2022A260A	DAMPER (C) ASSY CS-F33R
2-20	BZ-T2016A330A	DAMPER (B) ASSY GX-F35
2-21	ZS-479474	PAN26×05STL CMT
2-22	BI-312118	TAKE UP IDLER ASSY
2-23	ZG-314876	SP TORSION IDLER CLAMP (A)
2-24	ZG-314749	SP TORSION IDLER CLAMP (B)

MECHA BLOCK

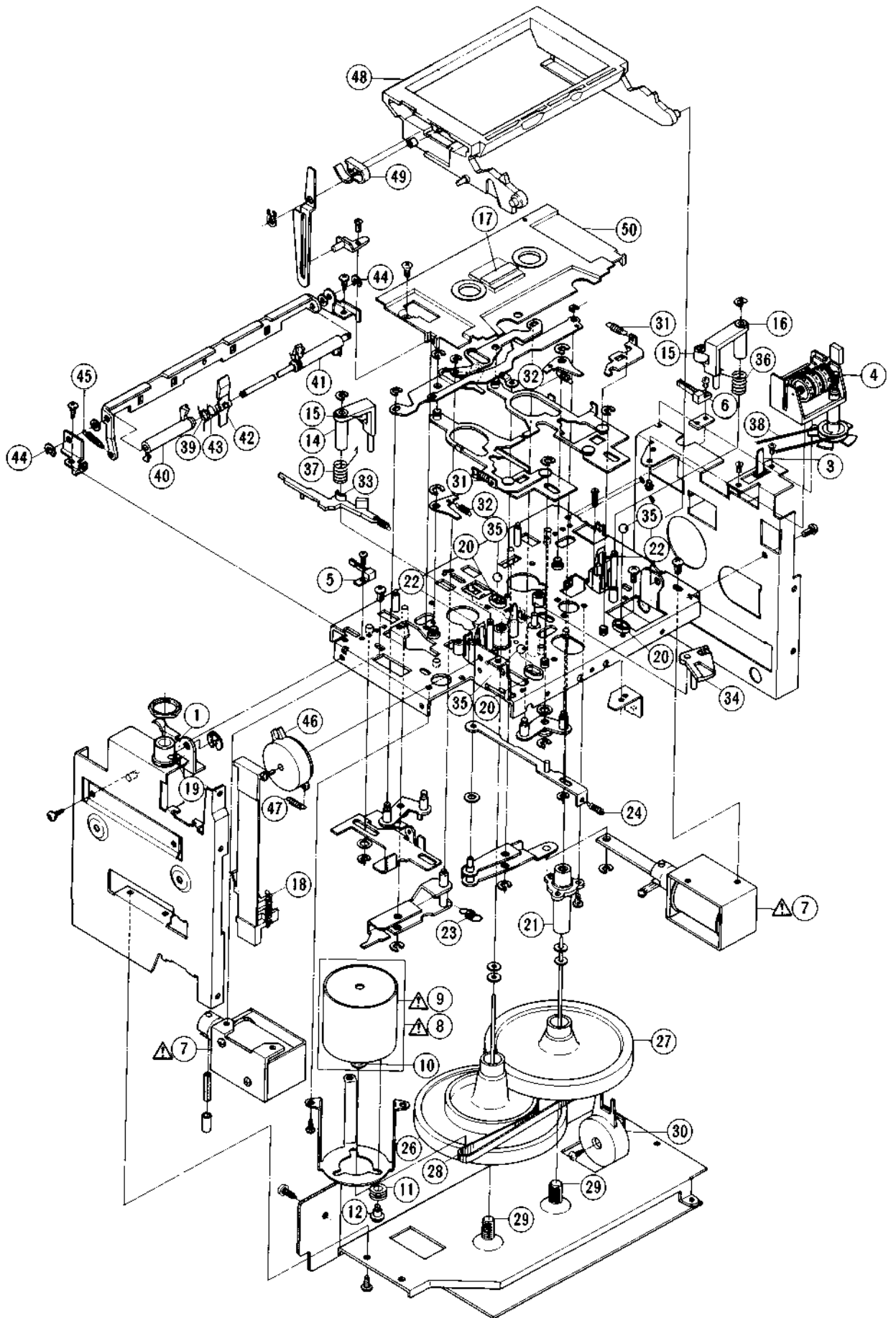

3. MECHA BLOCK

REF. No.	PARTS NO.	DESCRIPTION	REF. NO.	PARTS NO.	DESCRIPTION
PHONE JACK BLOCK					
3-1	EJ-336885	PHONE J 3P HLJ0607-023 6.3	3-48	TC-328351	CASSETTE HOLDER (BL)
3-2x	EJ-336886	PHONE J 3P HLJ0607-020 6.3 (P)	3-49	ZG-321487	MOLD SPRING
SW SLIDE BLOCK					
3-3	ES-330463	SW SLIDE 00230593 2-02-03S (SW901) (TIMER START)	3-50	BD-B342025	LID DECORATION PART
COUNTER BLOCK					
3-4	MC-342355	COUNTER ME360-152			
SW LEAF BLOCK					
3-5	ES-330521	SW LEAF BSW-47AB 01-1 NC (SW902) (FWD REC SAFETY)			
SW LEAF BLOCK					
3-6	ES-330522	SW LEAF BSW-47AC 01-1 NC (SW903) (REV REC SAFETY)			
PLUNGER ASSY					
3-7	EP-318644	Δ SOLENOID 1240PLT 27V (SL902, 903)			
MOTOR BLOCK					
3-8	BM-T2022A080A	Δ MOTOR (PULLEY) BLK CS-F33R			
3-9	BM-314843	Δ MOTOR EG-510ED-2F			
3-10	MR-328479	MOTOR PULLEY			
3-11	MB-282778	RUBBER BUSH			
3-12	ZS-321338	MOTOR SCREW			
3-13x	EO-669273	COIL FIX 2 FL5R200 18μH (FL1,2)			
PINCH ROLLER (L) BLOCK					
3-14	BL-T2041A110A	PINCH ROLLER (L) BLK CS-F39R			
3-15	MP-B342026	ROLLER PINCH PART			
PINCH ROLLER (R) BLOCK					
3-16	BL-T2041A120A	PINCH ROLLER (R) BLK CS-F39R			
D LED BLOCK					
3-17	ED-337010	D LED SLF-201C GRN (D1)			
MECHA BLOCK					
3-18	ZG-318204	SP T2-3.2/0.29-16 T2-062			
3-19	ZG-312944	SP T1-3.2/0.29-12.5 T1-060			
3-20	MS-302191	BALL GUIDE			
3-21	MV-328322	MAIN CASE			
3-22	TC-314156	HOLDER CASSETTE			
3-23	ZG-336651	SP PULL PLAY LEVER (A)			
3-24	ZG-312942	SP T1-3.2/0.29-10.0 T1-058			
3-25x	HZ-314069	SP PLATE HEAD BASE			
3-26	MI-B601782	FLYWHEEL (A) PART			
3-27	MI-B601783	FLYWHEEL (B) PART			
3-28	MB-314317	BELT CAPSTAN			
3-29	ZS-302318	HOLD SCREW			
3-30	BZ-T2016A330A	DAMPER (B) ASSY GX-F35			
3-31	ZG-318083	SP PULL CLAMP			
3-32	ZG-310531	SP T1-4.0/0.4-12.5 T1-109			
3-33	ML-314337	LEVER EJECT CHECK			
3-34	MR-314339	CAM HEAD CHANGE			
3-35	MV-269965	BALL 400STL			
3-36	ZG-310694	PINCH ROLLER RETURN SPRING (A)			
3-37	ZG-310695	PINCH ROLLER RETURN SPRING (B)			
3-38	MB-342028	BELT COUNTER			
3-39	ZG-336063	SP TORSION DETECTOR			
3-40	ML-314404	LEVER DETECTION (A)			
3-41	ML-314384	LEVER DETECTION (B)			
3-42	ML-332039	LEVER PACK HOLDER (C)			
3-43	ZG-332040	SP TORSION HOLDER			
3-44	ZW-270088	RING E 190SUP CMT			
3-45	ZG-336064	SP PULL EJECT			
3-46	BZ-T2016A290A	DAMPER (A) ASSY GX-F35			
3-47	ZG-324329	SP T2-3.2/0.29-11.2 T2-059			

When ordering parts, please quote Parts Number, Description and Model Number.

4. PRE AMP P.C BOARD BLOCK

REF. NO.	PARTS NO.	DESCRIPTION
4-1	BA-T2042A090A	PC PRE AMP BLK CS-F36R (U) (U,J,C,A)
4-2	BA-T2042A090B	PC PRE AMP BLK CS-F36R (E) (E,B,S,V)
PRE AMP P.C BOARD BLOCK		
4-IC1	EI-605013	IC NE545B
4-IC2	EI-336761	IC LA6458S
4-TR1	ET-319638	TR 2SD1012-V F,G,H
4-TR2,3	ET-603257	TR 2SC1312S G,H
4-TR4	ET-319638	TR 2SD1012-V F,G,H
4-TR5	ET-309353	Δ TR 2SC2274 E,F
4-TR6,7	ET-200505	TR 2SC2603 E,F
4-TR8	ET-200558	TR 2SA1115 E,F
4-TR9,10	ET-328868	TR 2SD1012-V G,H
4-TR12	ET-328868	TR 2SD1012-V G,H
4-TR13to20	ET-200505	TR 2SC2603 E,F
4-TR21	ET-328868	Δ TR 2SD1012-V G,H
4-TR22,23	ET-200505	TR 2SC2603 E,F
4-TR24	ET-328868	TR 2SD1012-V G,H
4-TR26,27	ET-328868	TR 2SD1012-V G,H
4-TR28	ET-310148	TR 2SD612K E,F
4-TR29	ET-200505	TR 2SC2603 E,F
4-TR30	ET-338081	Δ TR 2SB774 R,S
4-TR31to35	ET-200505	TR 2SC2603 E,F
4-TR37	ET-200505	TR 2SC2603 E,F
4-TR38	ET-317919	TR 2SC1061 C,D
4-TR39	ET-200505	TR 2SC2603 E,F
4-TR40,41	ET-310833	Δ TR 2SC2274K E
4-TR42	ET-200505	TR 2SC2603 E,F
4-D1to3	ED-309341	D GERMA H 1K34A
4-D4to7	ED-301911	D SILICON H DS448
4-D8	ED-306109	D SILICON W03B 100/1.0A
4-D9,10	ED-301911	D SILICON H DS448
4-D12to14	ED-301911	D SILICON H DS448
4-D15	ED-318859	D ZENER H HZ9 C2
4-D16to18	ED-301911	D SILICON H DS448
4-D19	ED-331198	D ZENER H HZ3 A1
4-D20to22	ED-301911	D SILICON H DS448
4-J1	EJ-332109	PHONE J HLJ0346-010 2x3P
4-J2	EJ-334235	PIN J P 4P (U,J,C,A)
4-J2	EJ-332437	JACK PLATE (E,B,S,V)
4-SW1	ES-311975	SW SOLENOID R8150050 27V 10-2W
4-SW2	ES-328415	SW SOLENOID SWE018401 18V 04-2S
4-VR1,2	EV-322415	R S-FIX H D8 3P 104
4-VR3	EV-322417	R S-FIX H D8 3P 303
4-VR4	EV-315540	R S-FIX H D8 3P 502
4-VR5	EV-315753	R S-FIX H D8 3P 203
4-VR6to9	EV-336785	R S-FIX H TM8KV2-1S 3P 0.50W 104
4-VR10	EV-322411	R S-FIX H D8 3P 202
4-VR11	EV-315542	R S-FIX H D8 3P 103
4-VL1	EO-321336	COIL VARI 1 FE002 10MH
4-L1	EO-330239	COIL FIX 1 FL09H 390μH J
4-L2	EO-669273	COIL FIX 2 FL5R200 18μH
4-L3	EO-316140	COIL FIX 1 RX9P-562J 5.60MH J
4-T1	EO-311974	COIL OSC1 0322-1034-022 100KHZ
4-RL1	EP-318648	RELAY LEAD LAB2NS2NO 6V
4-FL1	ER-328491	FILTER DB D07-003K 100KHZ
4-FL2	ER-328490	FILTER DB D07-001K 19KHZ
4-FR1	ER-318647	Δ R FUSE ERD2FC F10 1/4W 4R7J
4-FR2,3	ER-200595	Δ R FUSE ERD2FC F10 1/4W 5R6J
4-R109	ER-323996	Δ R OMF H SNP FS 1W 101J
4-R112	ER-331627	Δ R OMF H SNP FS 1W 910J
4-R119	ER-321251	Δ R CB H SNP FS RDS 1/2W 561J
4-C2	EC-334071	C STY V F05 CQ09S 391J 50DC
4-C4	EC-310440	C STY V F05 CQF09 471J 50DC
4-C54	EC-306022	C STY V F05 CQ09S 821J 50DC
4-C55	EC-324921	C STY V F05 CQ09S 101J 50DC
4-C59	EC-324921	C STY V F05 CQ09S 101J 50DC

REF. NO.	PARTS NO.	DESCRIPTION
4-C70	EC-337966	C PP V APS 103J 100DC
4-C72	EC-325380	C PP V F10 PFH 332J 630DC
4-C76	EC-307494	C STY V F05 CQ09S 331J 50DC
4-C86	EC-334072	C STY V F05 CQ09S 431J 50DC
LED P.C BOARD BLOCK		
4-D1to3	ED-337091	D LED LT9200N GRN
4-D4,5	ED-337092	D LED GL-9HY4 YLW
REVERSE SELECTOR P.C BOARD BLOCK		
4-SW1	ES-337322	SW SLIDE 00230699 2-02-03N
DETECTOR P.C BOARD BLOCK		
4-PH1	ET-311977	PHOTO SENSOR SPI-201
TAPE SELECTOR P.C BOARD BLOCK		
4-SW1	ES-337322	SW SLIDE 00230699 2-02-03N
DOLBY SW P.C BOARD BLOCK		
4-SW1,2	ES-338170	SW PUSH ESB-62267 2 THROW
REMOTE CONTROL P.C BOARD BLOCK		
4-J1	EJ-331215	DIN J TCS1881-101 P 8P
OPERATION P.C BOARD BLOCK		
4-SW1to8	ES-336780	SW TACT KHH10902
4-D1	ED-337014	D LED SR503D RED
4-D2	ED-337195	D LED SY403DA YLW

When ordering parts, please quote Parts Number, Description and Model Number.

5. SYS. CON. P.C BOARD BLOCK

REF. NO.	PARTS NO.	DESCRIPTION
5-1	BA-T2042A080A	PC SYSCON BLK CS-F36R
5-IC1	EI-311710	IC LM6402A-028
5-TR1	ET-200985	TR 2SC2603 F,G
5-TR2	ET-318237	Δ TR 2SB764 E,F
5-TR3	ET-309353	Δ TR 2SC2274 E,F
5-TR4	ET-200985	TR 2SC2603 F,G
5-TR5	ET-200558	TR 2SA1115 E,F
5-TR7	ET-309353	TR 2SC2274 E,F
5-TR8	ET-200985	TR 2SC2603 F,G
5-TR11	ET-309353	TR 2SC2274 E,F
5-TR12	ET-200985	TR 2SC2603 F,G
5-TR13	ET-328437	TR 2SD1012-V F,G
5-TR14	ET-328438	TR 2SB808-V F,G
5-TR15	ET-328437	TR 2SD1012-V F,G
5-TR16	ET-328438	TR 2SB808-V F,G
5-TR17to20	ET-200985	TR 2SC2603 F,G
5-TR21	ET-200558	TR 2SA1115, E,F
5-TR22to24	ET-200985	TR 2SC2603 F,G
5-TR25,26	ET-200558	TR 2SA1115 E,F
5-TR27to31	ET-200985	TR 2SC2603 F,G
5-TR33,34	ET-200985	TR 2SC2603 F,G
5-TR36,37	ET-200985	TR 2SC2603 F,G
5-TR38	ET-200558	TR 2SA1115 E,F
5-D1to3	ED-306109	D SILICON W03B 100/1.0A
5-D5	ED-306109	D SILICON W03B 100/1.0A
5-D9to12	ED-560913	D SILICON V 1S2473VE
5-D13,14	ED-308952	D GERMA V 1K34A-LR F07
5-D15to19	ED-560913	D SILICON V 1S2473VE
5-D22	ED-560913	D SILICON V 1S2473VE
5-VR1	EV-522652	R S-FIX V V8K1-1 3P 10S
5-L1	EO-669273	COIL FIX 2 FL5R200 18μH
5-X1	EZ-328406	OSC CE CSB400A 0.4MHZ
5-C9	EC-306980	C STY V F05 500 221J 50DC
5-C10	EC-306438	C STY V F05 500 101J 50DC

6. POWER P.C BOARD BLOCK

REF. NO.	PARTS NO.	DESCRIPTION
6-TR1	ET-307349	Δ TR 2SD794 P,Q
6-TR2	ET-200985	TR 2SC2603 F,G
6-TR3	ET-402682	Δ TR 2SC1061 C
6-TR4	ET-200985	TR 2SC2603 F,G
6-TR5	ET-307349	Δ TR 2SD794 P,Q
6-TR6	ET-200985	TR 2SC2603 F,G
6-D1,2	ED-330987	Δ D SILICON RB152 200/1.5A
6-D3	ED-329449	D ZENER H HZ18 3
6-D4	ED-319167	D ZENER H HZ6 C3
6-SW1	ES-312234	Δ SW PUSH SDL-1P 01-1 E (U,E,B,S,V)
6-SW1	ES-312235	Δ SW PUSH SDL-1P 01-1 J (J)
6-SW1	ES-312238	Δ SW PUSH SDL-1P 01-1 UC (C,A)
6-VS1	EJ-283140	Δ SOCKET SELECTER X-I7238 6P (U)
6-J1	EJ-310567	Δ SOCKET INLET 0378PC-GS E 2P (B,S,V)
6-J2	EJ-311843	PLUG MICRO CONNECTOR W-P13005 5P (EXCEPT U)
6-C1	EC-330308	Δ C MMY V ECQUF 103M 250AC (U)
6-C1	EC-320548	Δ C CE V F 103Z 250AC (J,C,A)
6-C1	EC-330308	Δ C MMY V ECQUF 103M 250AC (E,B,S,V)

7. METER P.C BOARD BLOCK

REF. NO.	PARTS NO.	DESCRIPTION
7-IC1	EI-315799	IC HA12019
7-IN1	EM-332427	IND FL BG-96Z GRAPH

ASSEMBLY BLOCK

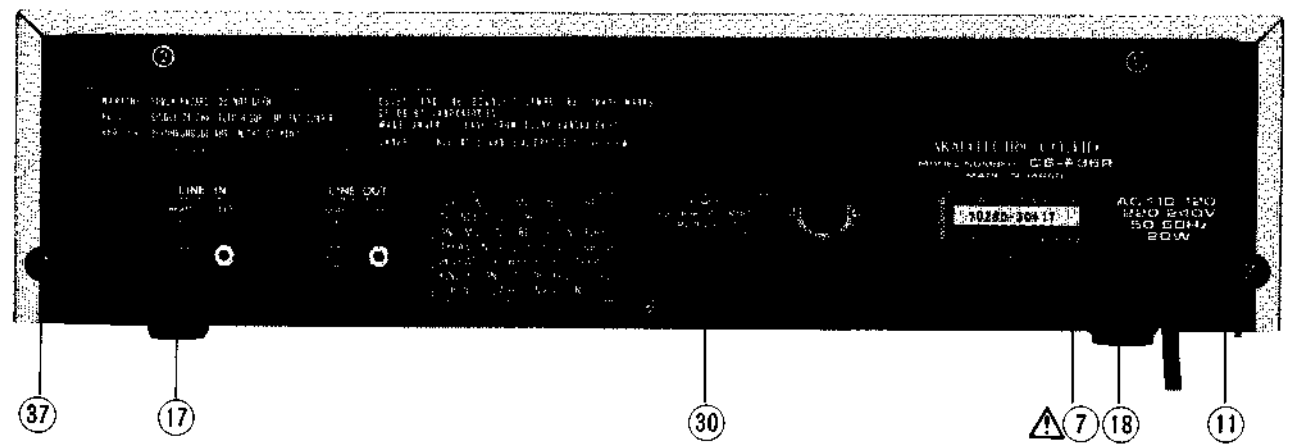
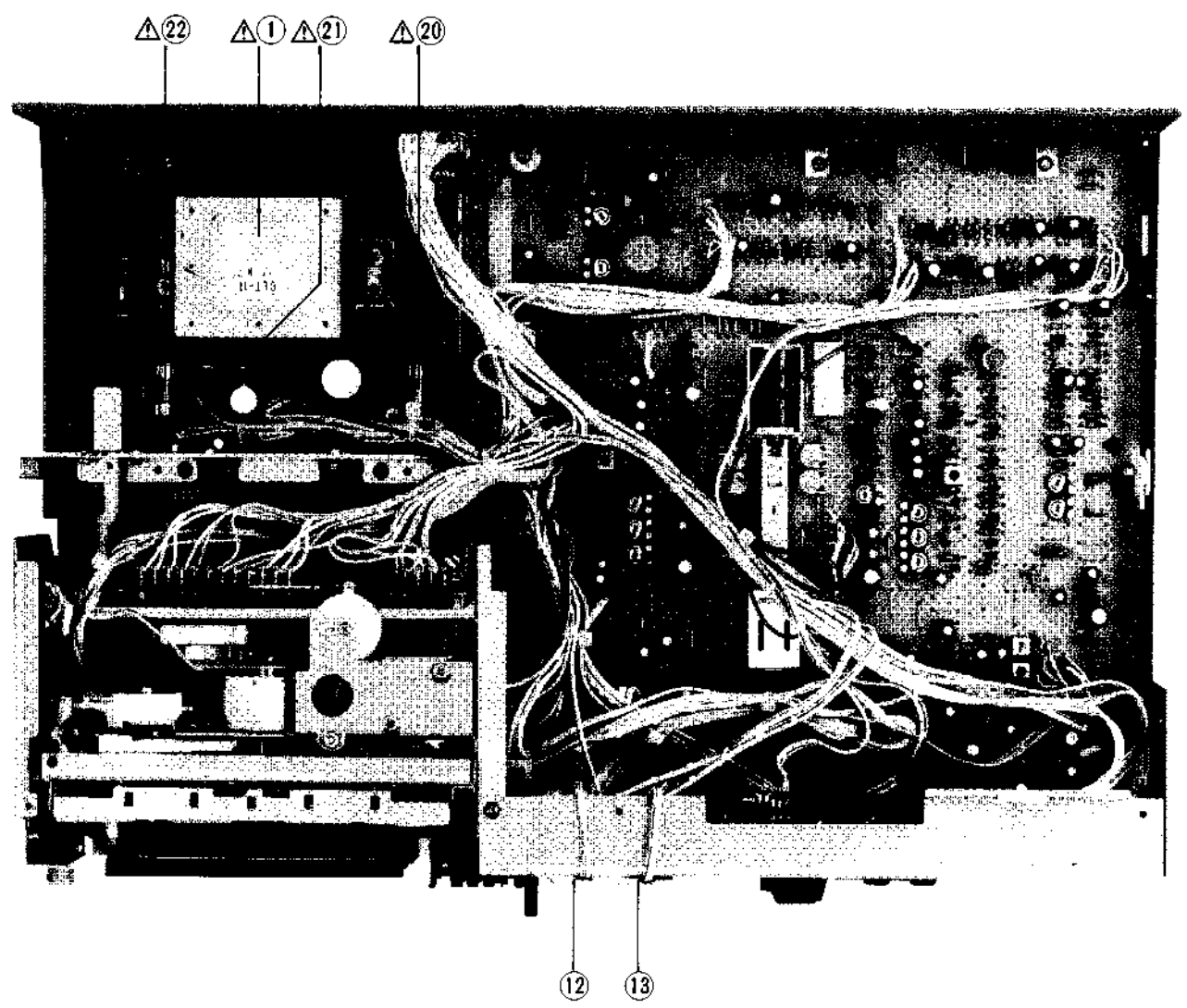

8. ASSEMBLY BLOCK

REF. NO.	PARTS NO.	DESCRIPTION
POWER BLOCK		
8-1	BT-311464	△ TRANS POWER CLT-11 (U)
8-2x	BT-311470	△ TRANS POWER CLT-12 (J)
8-3x	BT-311505	△ TRANS POWER CLT-15 (C)
8-4x	BT-311475	△ TRANS POWER CLT-14 (A)
8-5x	BT-311488	△ TRANS POWER CLT-13 (E,V)
8-6x	BT-311494	△ TRANS POWER CLT-16 (B,S)
8-7	EW-306428	△ AC CORD 2 CORES KP-205A, VFF J (U)
8-8x	EW-306427	△ AC CORD 2 CORES KP-211, VFF J (J)
8-9x	EW-305691	△ AC CORD 2 CORES KP-8, SPT-1 UC (C,A)
8-10x	EW-201796	△ AC CORD 2 CORES KP-419C, LTCE-2 F E (E)
8-11	SZ-631945	STRAIN RELIEF SR-4N-4 (U,J,C,A,E)
D LED (REV) BLOCK		
8-12	ED-337010	D LED SLF-201C GRN (D1)
D LED (FWD) BLOCK		
8-13	ED-337010	D LED SLF-201C GRN (D2)
ASSEMBLY BLOCK		
8-14x	ZW-312121	RV NYL26x042 BL
8-15x	ZW-231030	RV NYL30x045 BL
8-16x	EV-338033	VR SLIDE 100P1WV0A A104
8-17	SA-202118	FOOT
8-18	SA-313811	RUBBER FOOT
8-19x	ZW-231030	RV NYL30x045 BL
8-20	EF-311839	△ FUSE TSC A 250V 1.6A (F1) (U,J)
8-21	EF-306949	△ FUSE TSC A 250V 1.25A (F2) (U,J)
8-22	EF-309389	△ FUSE TSC A 250V 0.40A (F3) (U,J)
8-23x	EF-308847	△ FUSE TSC 125V 1.60A (F1)(C,A)
8-24x	EF-309392	△ FUSE TSC 125V 1.25A (F2)(C,A)
8-25x	EF-308848	△ FUSE TSC 125V 0.40A (F3)(C,A)
8-26x	EF-601964	△ FUSE SEMKO T 250V 1.60A (F1) (E,B,S,V)
8-27x	EF-602550	△ FUSE SEMKO T 250V 1.25A (F2) (E,B,S,V)
8-28x	EF-668474	△ FUSE SEMKO T 250V 0.40A (F3) (E,B,S,V)
8-29x	EF-602550	△ FUSE SEMKO T 250V 1.25A (F4) (E,B,S,V)
8-30	SP-342039P	PANEL REAR BOARD CS-F36R (U)
8-31x	SP-342039N	PANEL REAR BOARD CS-F36R (J)
8-32x	SP-342039M	PANEL REAR BOARD CS-F36R (C)
8-33x	SP-342039L	PANEL REAR BOARD CS-F36R (A)
8-34x	SP-342039K	PANEL REAR BOARD CS-F36R (E)
8-35x	SP-342039H	PANEL REAR BOARD CS-F36R(B,S)
8-36x	SP-342039J	PANEL REAR BOARD CS-F36R (V)
8-37	ZS-225134	T2PAN30x10STL CMT PW080
8-38x	ZW-305013	RV POP32 (A)
8-39x	EW-322400	△ AC CORD 2 CORES GTBS-2F/KS-15 B (B)
8-40x	EW-322401	△ AC CORD 2 CORES KP-560/S-15 S (S)
8-41x	EW-315767	△ AC CORD 2 CORES KP-419C/KS-15 E (V)

FINAL ASSEMBLY BLOCK

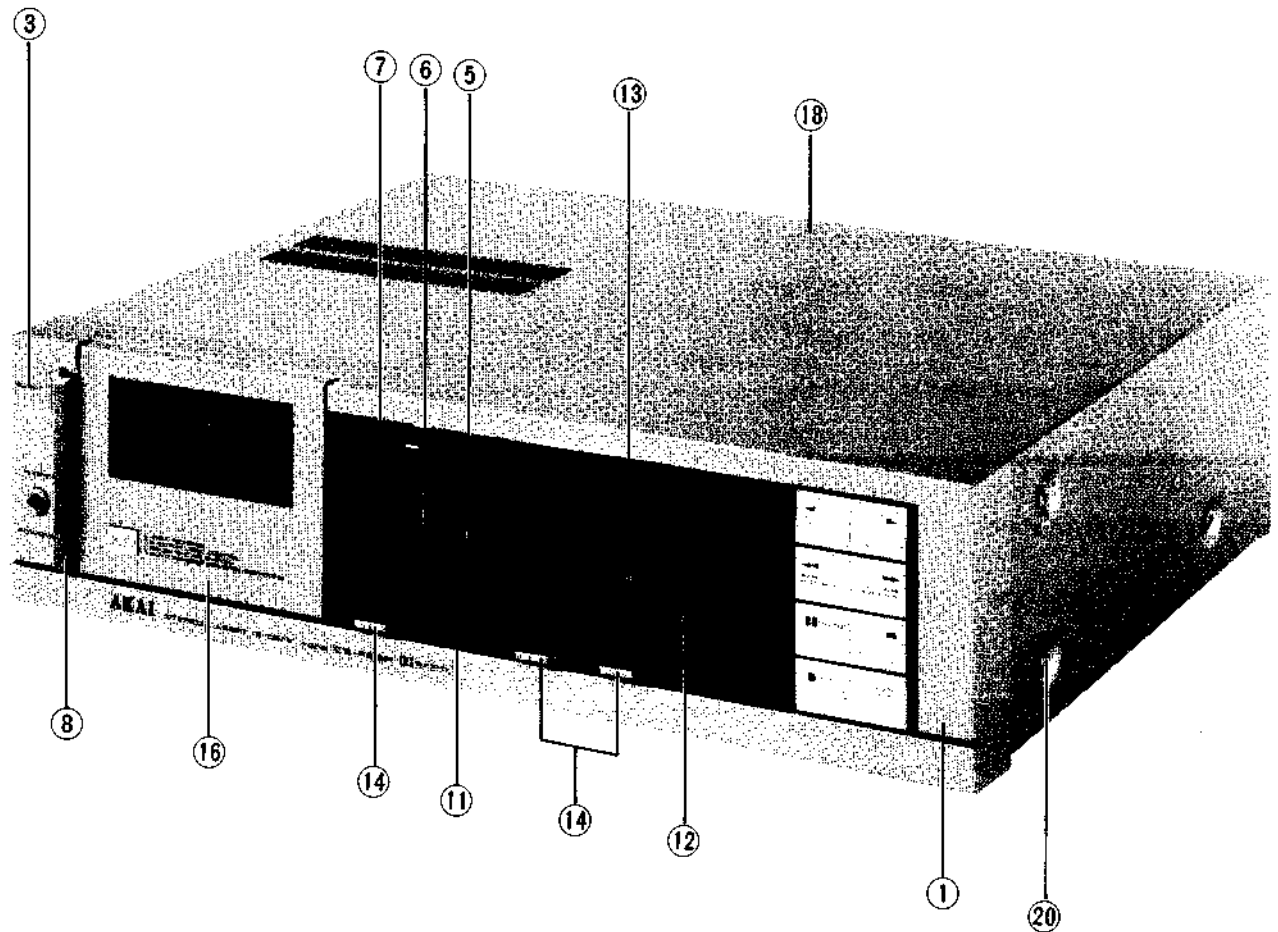

9. FINAL ASSEMBLY BLOCK

REF. NO.	PARTS NO.	DESCRIPTION
PANEL FRONT BLOCK		
9-1	BD-T2042A100A	PANEL FRONT BLK CS-F36R
9-2x	BD-T2042A100B	PANEL FRONT BLK CS-F36R-P
9-3	SK-342041A	KNOB EJECT
9-4x	SK-342041B	KNOB EJECT-P
9-5	SZ-342042	MASK
9-6	SK-342047B	KNOB DOLBY (3)
9-7	SK-342047C	KNOB DOLBY (4)
9-8	SK-342040A	KNOB POWER
9-9x	SK-342040B	KNOB POWER-P
9-10x	ZG-342051	SP RETURN
9-11	SK-341957	KNOB CAP
FINAL ASSEMBLY BLOCK		
9-12	SK-342056A	KNOB VR
9-13	SK-342056B	KNOB VR (B)
9-14	SK-342050A	KNOB SLIDE
9-15x	SK-342050B	KNOB SLIDE-P
9-16	BD-B342048C	LID PANEL (B) PART
9-17x	BD-B342048D	LID PANEL (B)-P PART
9-18	SP-332003D	COVER UPPER (C)
9-19x	SP-332003E	COVER UPPER (C)-P
9-20	ZS-341963	XST BID40x06STL NI3
9-21x	ZS-341964	ZST BID40x06STL BNI

When ordering parts, please quote Parts Number, Description and Model Number.

II. MODEL CS-F39R

RECOMMENDED SPARE PARTS

Because, if the parts listed below are on hand, almost any repair can be accomplished, we suggest that you stock these Recommended Spare Parts Items.

NO.	PARTS NO.	DESCRIPTION	NO.	PARTS NO.	DESCRIPTION
1	BH-T2041A090A	HEAD BLK CS-F39R	63	EO-316140	COIL FIX 1 RX9P-562J 5.60MH J
2	BI-312117	REW IDLER ASSY	64	EO-669273	COIL FIX 2 FL5R200 18μH
3	BI-312118	TAKE UP IDLER ASSY	65	EO-337044	COIL FIX 2 102AK-005 36MH
4	BL-T2010D090A	PINCH ROLLER (L) BLK CS-M40R	66	EO-311974	COIL OSC 1 0322-1034-022 100 kHz
5	BL-T2010D100A	PINCH ROLLER (R) BLK CS-M40R	67	EO-321336	COIL VARI 1 FE002 10MH
6	BM-T2022A080A	Δ MOTOR (PULLEY) BLK CS-F33R	68	EP-318644	Δ SOLENOID 1240PLT 27V
7	BM-314843	Δ MOTOR EG-510ED-2F	69	EP-318645	Δ SOLENOID 1240PLT 27V
8	BM-328441	Δ MOTOR RF-510T (12620)	70	EP-318648	RELAY LEAD LAB2NS 2NO 6V
9	BM-T2016A320A	Δ REEL MOTOR BLK (W/PULLEY) GX-F35	71	ER-318647	Δ R FUSE ERD2FC F10 1/4W 4R7J
10	BR-328424	TAKE-UP REEL TABLE ASSY	72	ER-200595	Δ R FUSE ERD2FC F10 1/4W 5R6J
11	BT-311464	Δ TRANS POWER CLT-11 (U)	73	ER-336775	FILTER DB D07001K 19KHZ
12	BT-311470	Δ TRANS POWER CLT-12 (J)	74	ER-336776	FILTER DB D07003K 100KHZ
13	BT-311488	Δ TRANS POWER CLT-13 (E,V)	75	ES-312234	Δ SW PUSH SDL-1P 01-1 E (U,E,B,S,V)
14	BT-311475	Δ TRANS POWER CLT-14 (A)	76	ES-312235	Δ SW PUSH SDL-1P 01-1 J (J)
15	BT-311505	Δ TRANS POWER CLT-15 (C)	77	ES-312238	Δ SW PUSH SDL-1P 01-1 UC (C,A)
16	BT-311494	Δ TRANS POWER CLT-16 (B,S)	78	ES-330521	SW LEAF BSW-47AB 01-1 NC
17	BZ-T2016A290A	DAMPER (A) ASSY GX-F35	79	ES-330522	SW LEAF BSW-47AC 01-1 NC
18	BZ-T2016A330A	DAMPER (B) ASSY GX-F35	80	ES-338036	SW PUSH ESB-62259 3 THROW
19	BZ-T2022A260A	DAMPER (C) ASSY CS-F33R	81	ES-330463	SW SLIDE 00230593 2-02-03S
20	BZ-T2041A100A	DETECTION TAPE GUIDE BLK CS-F39R	82	ES-337322	SW SLIDE 00230699 2-02-03N
21	ED-309341	D GERMA H 1K34A	83	ES-311975	SW SOLENOID R8150050 27V 10-2W
22	ED-308952	D GERMA V 1K34A-LR F07	84	ES-336780	SW TACT KHH10902
23	ED-337092	D LED GL-9HY4 YLW	85	ET-311977	PHOTO SENSOR SPI-201
24	ED-337091	D LED LT9200N GRN	86	ET-200558	TR 2SA1115 E,F
25	ED-337010	D LED SLF-201C GRN	87	ET-318237	TR 2SB764 E,F
26	ED-337014	D LED SR503D RED	88	ET-338081	TR 2SB774 R,S
27	ED-337195	D LED SY403DA YLW	89	ET-328438	TR 2SB808-V F,G
28	ED-301911	D SILICON H DS448	90	ET-402682	TR 2SC1061 C
29	ED-330987	D SILICON RB152 200/1.5A	91	ET-317919	TR 2SC1061 C,D
30	ED-200468	D SILICON V DS448-VB6	92	ET-603257	TR 2SC1312S G,H
31	ED-560913	D SILICON V 1S2473VE	93	ET-309353	TR 2SC2274 E,F
32	ED-306109	D SILICON W03B 100/1.0A	94	ET-200505	TR 2SC2603 E,F
33	ED-329449	D ZENER H HZ 18 3	95	ET-200985	TR 2SC2603 F,G
34	ED-319167	D ZENER H HZ6 C3	96	ET-328437	TR 2SD1012-V F,G
35	ED-338342	D ZENER V HZ3A-1S1	97	ET-328868	TR 2SD1012-V G,H
36	ED-338082	D ZENER V HZ5C-1S1	98	ET-310148	TR 2SD612K E,F
37	ED-338454	D ZENER V HZ9C-2S1	99	ET-307349	TR 2SD794 P,Q
38	ED-338083	D ZENER V HZ9C-3S1	100	ET-318239	TR 2SD863 E,F
39	EF-668474	Δ FUSE SEMKO T 250V 0.40A (F3) (E,B,S,V)	101	EV-315542	R S-FIX H D8 3P 103
40	EF-602550	Δ FUSE SEMKO T 250V 1.25A (F2) (E,B,S,V)	102	EV-322415	R S-FIX H D8 3P 104
41	EF-602550	Δ FUSE SEMKO T 250V 1.25A (F4) (B)	103	EV-322411	R S-FIX H D8 3P 202
42	EF-601964	Δ FUSE SEMKO T 250V 1.60A (F1) (E,B,S,V)	104	EV-315753	R S-FIX H D8 3P 203
43	EF-309389	Δ FUSE TSC A 250V 0.40A (F3) (U,J)	105	EV-322417	R S-FIX H D8 3P 303
44	EF-306949	Δ FUSE TSC A 250V 1.25A (F2) (U,J)	106	EV-315540	R S-FIX H D8 3P 502
45	EF-311839	Δ FUSE TSC A 250V 1.6A (F1) (U,J)	107	EV-336785	R S-FIX H TM8KV2-1S 3P 0.50W 104
46	EF-308848	Δ FUSE TSC 125V 0.40A(F3)(C,A)	108	EV-522652	R S-FIX V V8K1-1 3P 105
47	EF-309392	Δ FUSE TSC 125V 1.25A(F2)(C,A)	109	EV-338033	VR SLIDE 100P1WV0A A104
48	EF-308847	Δ FUSE TSC 125V 1.60A(F1)(C,A)	110	EZ-328406	OSC CE CSB400A 0.4 MHZ
49	EI-315799	IC HA12019	111	HE-325859	HEAD E HF213131 C
50	EI-336983	IC HA12038	112	HE-325859	HEAD E HF213131 C
51	EI-336761	IC LA6458S	113	HP-311634	HEAD R/P RP-S042-CM-0510 C
52	EI-311710	IC LM6402A-028	114	MB-314317	BELT CAPSTAN
53	EJ-310567	Δ SOCKET INLET 0378PC-GS E 2P	115	MB-342028	BELT COUNTER
54	EJ-283140	Δ SOCKET SELECTER X-17238 6P	116	MC-342319	COUNTER SME366-003
55	EJ-331215	DIN J TCS1881-101 P 8P	117	MI-B601782	FLYWHEEL (A) PART
56	EJ-332437	JACK PLATE (E,B,S,V)	118	MI-B601783	FLYWHEEL (B) PART
57	EJ-332109	PHONE J HLJ0346-010 2x3P	119	MP-B342026	ROLLER PINCH PART
58	EJ-336886	PHONE J 3P HLJ0607-020 6.3 (P)	120	MV-328322	MAIN CASE
59	EJ-336885	PHONE J 3P HLJ0607-023 6.3			
60	EJ-332435	PIN J P 4P (U,J,C,A)			
61	EM-332427	IND FL BG-96Z GRAPH			
62	EO-330239	COIL FIX 1 FL09H 390μH J			

When ordering parts, please quote Parts Number, Description and Model Number.

HEAD BLOCK

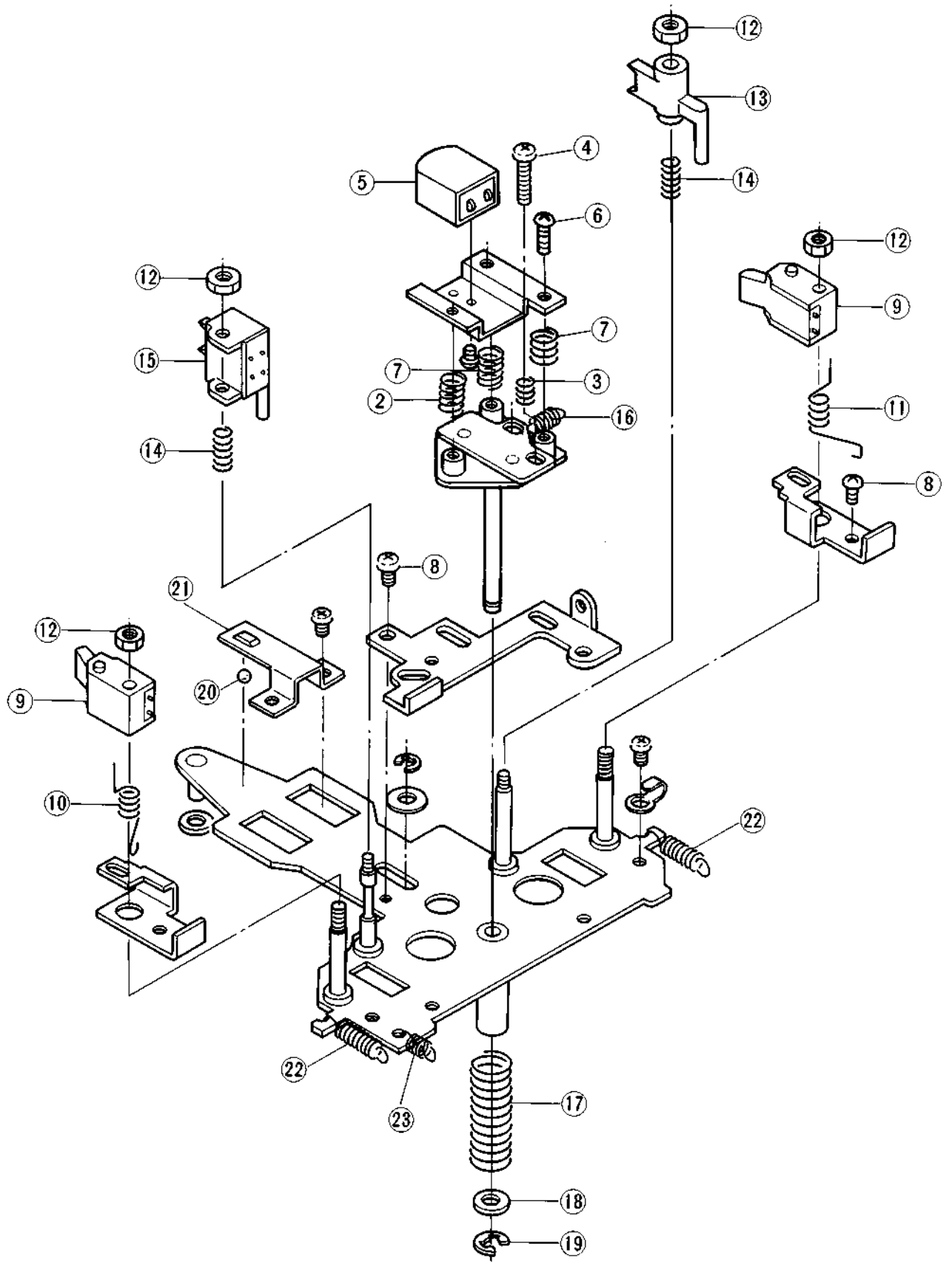

1. HEAD BLOCK

REF. NO.	PARTS NO.	DESCRIPTION
1-1x	BH-T2041A090A	HEAD BLK CS-F39R
1-2	ZG-369088	ANGLE ADJUST SPRING
1-3	ZG-402895	CS ANGLE ADJUST SPRING
1-4	ZS-465298	PAN23x10STL CMT
1-5	HP-311634	HEAD R/P RP-S042-CM-0510 C
1-6	ZS-608106	PAN20x06STL CMT
1-7	ZG-328305	ANGLE SPRING
1-8	ZS-592378	PAN26x03STL CMT
1-9	HE-325859	HEAD E HF213131 C
1-10	ZG-313316	ERASE HEAD SPRING (A)
1-11	ZG-313874	ERASE HEAD SPRING (B)
1-12	ZW-618884	N20STL CMT 1
1-13	HZ-313313	TAPE GUIDE
1-14	ZG-313314	ADJUST SPRING
1-15	BZ-T2041A100A	DETECTION TAPE GUIDE BLK CS-F39R
1-16	ZG-330078	SP T2-3.2/0.2-9.0 T2-038
1-17	ZG-313960	SP PUSH
1-18	ZW-556828	PW32x100x050 STL CMT
1-19	ZW-270088	RING E 190SUP CMT
1-20	MV-357208	BALL200STL
1-21	MH-314340	HEAD HOLDER
1-22	ZG-312946	SP T1-3.2/0.29-16.0 T1-062
1-23	ZG-312921	SP T1-3.2/0.2-9.0 T1-038

REEL TABLE BLOCK

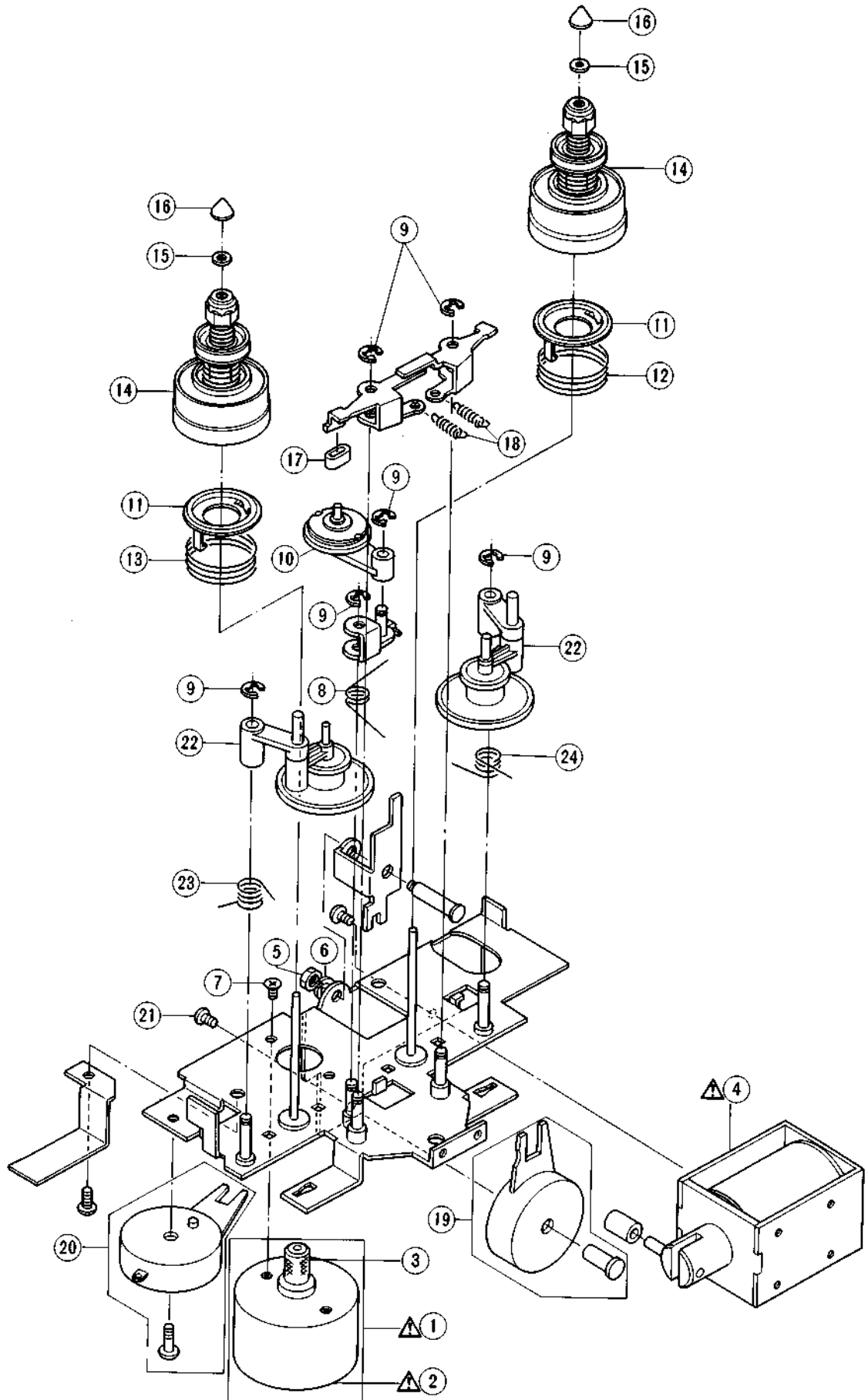

2. REEL TABLE BLOCK

REF. NO.	PARTS NO.	DESCRIPTION
REEL MOTRO BLOCK		
2-1	BM-T2016A320A	△ REEL MOTOR BLK (W/PULLEY) GX-F35
2-2	BM-328441	△ MOTOR RF-510T (12620)
2-3	MR-328360	REEL MOTOR PULLEY
PLUNGER ASSY		
2-4	EP-318645	△ SOLENOID 1240PLT 27V(SL901)
REEL TABLE BLOCK		
2-5	ZW-516993	N30STL CMT 1
2-6	ZW-273745	SW30
2-7	ZS-430413	CTS26x04STL CMT
2-8	ZG-314747	SP TORSION IDLER
2-9	ZW-270088	RING E 190SUP CMT
2-10	BI-312117	REW IDLER ASSY
2-11	TC-328365	BT DRUM
2-12	ZG-328366	BT SPRING
2-13	ZG-330049	SP PUSH BACK TENSION
2-14	BR-328424	TAKE-UP REEL TABLE ASSY
2-15	ZW-330073	PW21x040x020
2-16	MT-305793	REEL CAP
2-17	MB-282104	BRAKE RUBBER
2-18	ZG-321534	SP T2-3.2/0.29-12.5 T2-060
2-19	BZ-T2022A260A	DAMPER (C) ASSY CS-F33R
2-20	BZ-T2016A330A	DAMPER (B) ASSY GX-F35
2-21	ZS-479474	PAN26x05STL CMT
2-22	BI-312118	TAKE UP IDLER ASSY
2-23	ZG-314876	SP TORSION IDLER CLAMP (A)
2-24	ZG-314749	SP TORSION IDLER CLAMP (B)

MECHA BLOCK

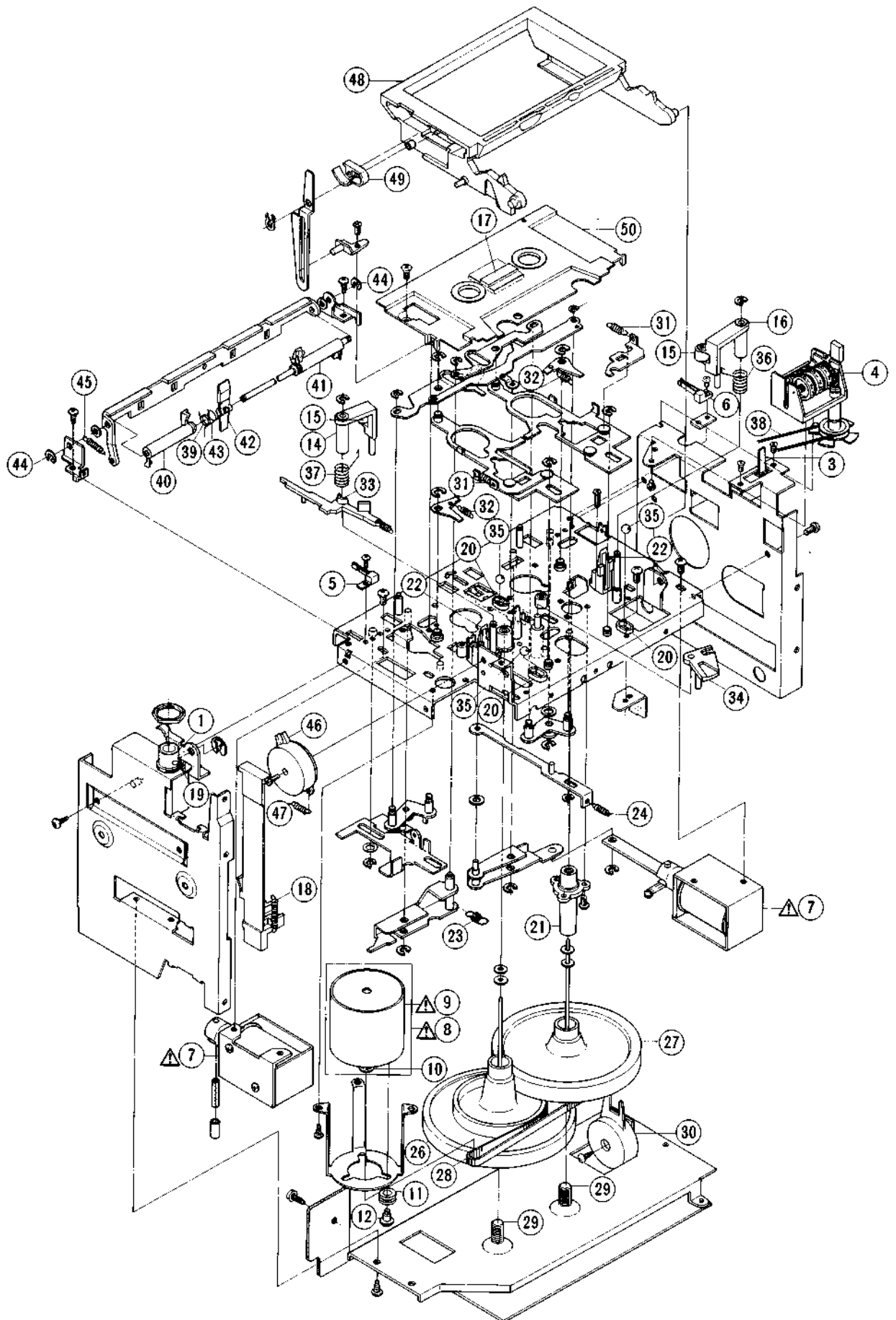

3. MECHA BLOCK

REF. NO.	PARTS NO.	DESCRIPTION	REF. NO.	PARTS NO.	DESCRIPTION
PHONE JACK BLOCK					
3-1	EJ-336885	PHONE J 3P HLJ0607-023 6.3	3-48	TC-328351	CASSETTE HOLDER (BL)
3-2x	EJ-336886	PHONE J 3P HLJ0607-020 6.3 (P)	3-49	ZG-321487	MOLD SPRING
			3-50	BD-B342025	LID DECORATION PART
SW SLIDE BLOCK					
3-3	ES-330463	SW SLIDE 00230593 2-02-03S (SW901) (TIMER START)			
COUNTER BLOCK					
3-4	MC-342319	COUNTER SME366-003			
SW LEAF BLOCK					
3-5	ES-330521	SW LEAF BSW-47AB 01-1 NC (SW902) (FWD REC SAFETY)			
SW LEAF BLOCK					
3-6	ES-330522	SW LEAF BSW-47AC 01-1 NC (SW903) (REV REC SAFETY)			
PLUNGER ASSY					
3-7	EP-318644	Δ SOLENOID 1240PLT 27V (SL902,903)			
MOTOR BLOCK					
3-8	BM-T2022A080A	Δ MOTOR (PULLEY) BLK CS-F33R			
3-9	BM-314843	Δ MOTOR EG-510ED-2F			
3-10	MR-328479	MOTOR PULLEY			
3-11	MB-282778	RUBBER BUSH			
3-12	ZS-321338	MOTOR SCREW			
3-13x	EO-669273	COIL FIX 2 FL5R200 18μH (FL1,2)			
PINCH ROLLER (L) BLOCK					
3-14	BL-T2041A110A	PINCH ROLLER (L) BLK CS-F39R			
3-15	MP-B342026	ROLLER PINCH PART			
PINCH ROLLER (R) BLOCK					
3-16	BL-T2041A120A	PINCH ROLLER (R) BLK CS-F39R			
D LED BLOCK					
3-17	ED-337010	D LED SLF-201C GRN (D1)			
MECHA BLOCK					
3-18	ZG-318204	SP T2-3.2/0.29-16 T2-062			
3-19	ZG-312944	SP T1-3.2/0.29-12.5 T1-060			
3-20	MS-302191	BALL GUIDE			
3-21	MV-328322	MAIN CASE			
3-22	TC-314156	HOLDER CASSETTE			
3-23	ZG-336651	SP PULL PLAY LEVER (A)			
3-24	ZG-312942	SP T1-3.2/0.29-10.0 T1-058			
3-25x	HZ-314069	SP PLATE HEAD BASE			
3-26	MI-B601782	FLYWHEEL (A) PART			
3-27	MI-B601783	FLYWHEEL (B) PART			
3-28	MB-314317	BELT CAPSTAN			
3-29	ZS-302318	HOLD SCREW			
3-30	BZ-T2016A330A	DAMPER (B) ASSY GX-F35			
3-31	ZG-318083	SP PULL CLAMP			
3-32	ZG-310531	SP T1-4.0/0.4-12.5 T1-109			
3-33	ML-314337	LEVER EJECT CHECK			
3-34	MR-314339	CAM HEAD CHANGE			
3-35	MV-269965	BALL 400STL			
3-36	ZG-310694	PINCH ROLLER RETURN			
		SPRING (A)			
3-37	ZG-310695	PINCH ROLLER RETURN			
		SPRING (B)			
3-38	MB-342028	BELT COUNTER			
3-39	ZG-336063	SP TORSION DETECTOR			
3-40	ML-314404	LEVER DETECTION (A)			
3-41	ML-314384	LEVER DETECTION (B)			
3-42	ML-332039	LEVER PACK HOLDER (C)			
3-43	ZG-332040	SP TORSION HOLDER			
3-44	ZW-270088	RING E 190SUP CMT			
3-45	ZG-336064	SP PULL EJECT			
3-46	BZ-T2016A290A	DAMPER (A) ASSY GX-F35			
3-47	ZG-324329	SP T2-3.2/0.29-11.2 T2-059			

When ordering parts, please quote Parts Number, Description and Model Number.

4. PRE AMP P.C BOARD BLOCK

REF. NO.	PARTS NO.	DESCRIPTION
4-1	BA-T2041A150A	PC PRE AMP BLK CS-F39R (U) (U,J,C,A)
4-2	BA-T2041A150B	PC PRE AMP BLK CS-F39R (E) (E,B,S,V)
PRE AMP P.C BOARD BLOCK		
4-IC1	EI-336983	IC HA12038
4-IC2,3	EI-336761	IC LA6458S
4-TR1	ET-328437	TR 2SD1012-V F,G
4-TR2,3	ET-603257	TR 2SC1312S G,H
4-TR4	ET-200505	TR 2SC2603 E,F
4-TR5	ET-318239	Δ TR 2SD863 E,F
4-TR6to8	ET-200505	TR 2SC2603 E,F
4-TR9	ET-200558	TR 2SA1115 E,F
4-TR10,11	ET-328868	TR 2SD1012-V G,H
4-TR12	ET-603257	TR 2SC1312S G,H
4-TR13	ET-328437	TR 2SD1012-V F,G
4-TR14to20	ET-200505	TR 2SC2603 E,F
4-TR21,22	ET-309353	Δ TR 2SC2274 E,F
4-TR23to25	ET-200505	TR 2SC2603 E,F
4-TR26	ET-328868	TR 2SD1012-V G,H
4-TR27,28	ET-200505	TR 2SC2603 E,F
4-TR29	ET-328868	TR 2SD1012-V G,H
4-TR30	ET-310148	Δ TR 2SD612K E,F
4-TR31,32	ET-200505	TR 2SC2603 E,F
4-TR33	ET-338081	TR 2SB774 R,S
4-TR34to36	ET-200505	TR 2SC2603 E,F
4-TR38,39	ET-200505	TR 2SC2603 E,F
4-TR40	ET-317919	Δ TR 2SC1061 C,D
4-TR41	ET-603257	TR 2SC1312S G,H
4-TR42	ET-200505	TR 2SC2603 E,F
4-TR43	ET-200985	TR 2SC2603 F,G
4-D1	ED-338082	D ZENER V HZ5C-1S1
4-D2,3	ED-309341	D GERMA H 1K34A
4-D4	ED-301911	D SILICON H DS448
4-D8,9	ED-301911	D SILICON H DS448
4-D10	ED-338083	D ZENER V HZ9C-3S1
4-D11to13	ED-301911	D SILICON H DS448
4-D14	ED-338454	D ZENER V HZ9C-2S1
4-D15	ED-301911	D SILICON H DS448
4-D17to20	ED-301911	D SILICON H DS448
4-D21	ED-338342	D ZENER V HZ3A-1S1
4-D22to24	ED-301911	D SILICON H DS448
4-J1	EJ-332109	PHONE J HLJ0346-010 2x3P
4-J2	EJ-332435	PIN J P 4P (U,J,C,A)
4-J2	EJ-332437	JACK PLATE (E,B,S,V)
4-SW1	ES-311975	SW SOLENOID R8150050 27V 10-2W
4-VR1,2	EV-322415	R S-FIX H D8 3P 104
4-VR3	EV-322417	R S-FIX H D8 3P 303
4-VR5	EV-315753	R S-FIX H D8 3P 203
4-VR6to9	EV-336785	R S-FIX H TM8KV2-1S 3P 0.50W 104
4-VR10	EV-322411	R S-FIX H D8 3P 202
4-VR11	EV-315542	R S-FIX H D8 3P 103
4-VR12	EV-315540	R S-FIX H D8 3P 502
4-RL1	EP-318648	RELAY LEAD LAB2NS 2NO 6V
4-VL1	EO-321336	COIL VARI 1 FE002 10MH
4-L1	EO-330239	COIL FIX 1 FL09H 390μH J
4-L2	EO-669273	COIL FIX 2 FL5R200 18μH
4-L3	EO-316140	COIL FIX 1 RX9P-562J 5.60MH J
4-T1	EO-311974	COIL OSC1 0322-1034-022 100KHZ
4-FL1	EO-337044	COIL FIX 2 102AK-005 36MH
4-FL2	ER-336776	FILTER DB D07003K 100KHZ
4-FL3	ER-336775	FILTER DB D07001K 19KHZ
4-R132	ER-333668	Δ R CB H SNP FS RDS 1/2W 431J
4-R143	ER-321251	Δ R CB H SNP FS RDS 1/2W 561J
4-FR1	ER-318647	Δ R FUSE ERD2FC F10 1/4W 4R7J
4-FR2,3	ER-200595	Δ R FUSE ERD2FC F10 1/4W 5R6J

REF. NO.	PARTS NO.	DESCRIPTION
4-C1	EC-334071	C STY V F05 CQ09S 391J 50DC
4-C3	EC-308142	C STY V F05 CQ09S 471J 50DC
4-C71	EC-306022	C STY V F05 CQ09S 821J 50DC
4-C72,73	EC-316570	C STY V SNP CQFS 101J 250DC
4-C74	EC-325380	C PP V F10 PFH 332J 630DC
4-C76	EC-337966	C PP V APS 103J 100DC
4-C81	EC-306018	C STY V F05 CQ09S 681J 50DC
4-C100	EC-334211	C STY V T05 CQT09 431J 50DC
LED P.C BOARD BLOCK		
4-D1to3	ED-337091	D LED LT9200N GRN
4-D4to6	ED-337092	D LED GL-9HY4 YLW
REVERSE SELECTOR P.C BOARD BLOCK		
4-SW1	ES-337322	SW SLIDE 00230699 2-02-03N
DETECTOR P.C BOARD BLOCK		
4-PH1	ET-311977	PHOTO SENSOR SPI-201
TAPE SELECTOR P.C BOARD		
4-SW1	ES-337322	SW SLIDE 00230699 2-02-03N
DOLBY SW P.C BOARD BLOCK		
4-SW1to3	ES-338036	SW PUSH ESB-62259 3 THROW
REMOTE CONTROL P.C BOARD BLOCK		
4-J1	EJ-331215	DIN J TCS1881-101 P 8P
OPERATION P.C BOARD BLOCK		
4-D1	ED-337014	D LED SR503D RED
4-D2	ED-337195	D LED SY403DA YLW
4-SW1to8	ES-336780	SW TACT KHH10902

5. SYS. CON. P.C BOARD BLOCK

REF. NO.	PARTS NO.	DESCRIPTION
5-I	BA-T2041A140A	PC SYSCON BLK CS-F39R
SYS. CON. P.C BOARD BLOCK		
5-IC1	EI-311710	IC LM6402A-028
5-TR1	ET-200985	TR 2SC2603 F,G
5-TR2	ET-318237	Δ TR 2SB764 E,F
5-TR3	ET-309353	Δ TR 2SC2274 E,F
5-TR4	ET-200985	TR 2SC2603 F,G
5-TR5	ET-200558	TR 2SA1115 E,F
5-TR7	ET-309353	TR 2SC2274 E,F
5-TR8	ET-200985	TR 2SC2603 F,G
5-TR11	ET-309353	TR 2SC2274 E,F
5-TR12	ET-200985	TR 2SC2603 F,G
5-TR13	ET-328437	TR 2SD1012-V F,G
5-TR14	ET-328438	TR 2SB808-V F,G
5-TR15	ET-328437	TR 2SD1012-V F,G
5-TR16	ET-328438	TR 2SB808-V F,G
5-TR17to20	ET-200985	TR 2SC2603 F,G
5-TR21	ET-200558	TR 2SA1115 E,F
5-TR22to24	ET-200985	TR 2SC2603 F,G
5-TR25,26	ET-200558	TR 2SA1115 E,F
5-TR27to31	ET-200985	TR 2SC2603 F,G
5-TR33to37	ET-200985	TR 2SC2603 F,G
5-TR38	ET-200558	TR 2SA1115 E,F
5-D1to3	ED-306109	D SILICON W03B 100/1.0A
5-D5	ED-306109	D SILICON W03B 100/1.0A
5-D9to12	ED-560913	D SILICON V 1S2473VE
5-D13,14	ED-308952	D GERMA V 1K34A-LR F07
5-D15to19	ED-560913	D SILICON V 1S2473VE
5-D20,21	ED-200468	D SILICON V DS448-VB6
5-D22	ED-560913	D SILICON V 1S2473VE
5-VR1	EV-522652	R S-FIX V V8K1-1 3P 105
5-L1	EO-669273	COIL FIX 2 FL5R200 18μH
5-X1	EZ-328406	OSC CE CSB400A 0.4MHZ
5-C9	EC-306980	C STY V F05 500 221J 50DC
5-C10	EC-306438	C STY V F05 500 101J 50DC
AUTO SYSTEM P.C BOARD BLOCK		
5-SW1	ES-330463	SW SLIDE 00230593 2-02-03S

6. POWER P.C BOARD BLOCK

REF. NO.	PARTS NO.	DESCRIPTION
6-TR1	ET-307349	Δ TR 2SD794 P,Q
6-TR2	ET-200985	TR 2SC2603 F,G
6-TR3	ET-402682	Δ TR 2SC1061 C
6-TR4	ET-200985	TR 2SC2603 F,G
6-TR5	ET-307349	Δ TR 2SD794 P,Q
6-TR6	ET-200985	TR 2SC2603 F,G
6-D1,2	ED-330987	Δ D SILICON RB152 200/1.5A
6-D3	ED-329449	D ZENER H HZ18 3
6-D4	ED-319167	D ZENER H HZ6 C3
6-SW1	ES-312234	Δ SW PUSH SDL-1P 01-1 E (U,E,B,S,V)
6-SW1	ES-312235	Δ SW PUSH SDL-1P 01-1 J (J)
6-SW1	ES-312238	Δ SW PUSH SDL-1P 01-1 UC (C,A)
6-VS1	EJ-283140	Δ SOCKET SELECTER X-17238 6P (U)
6-J1	EJ-310567	Δ SOCKET INLET 0378PC-GS E 2P (B,S,V)
6-J2	EJ-311843	PLUG MICRO CONNECTOR W-P13005 5P (EXCEPT U)
6-C1	EC-330308	Δ C MMY V ECQUF 103M 250AC (U)
6-C1	EC-320548	Δ C CE V F 103Z 250AC (J,C,A)
6-C1	EC-330308	Δ C MMY V ECQUF 103M 250AC (E,B,S,V)

7. METER P.C BOARD BLOCK

REF. NO.	PARTS NO.	DESCRIPTION
7-IC1	EI-315799	IC HA12019
7-IN1	EM-332427	IND FL BG-96Z GRAPH

ASSEMBLY BLOCK

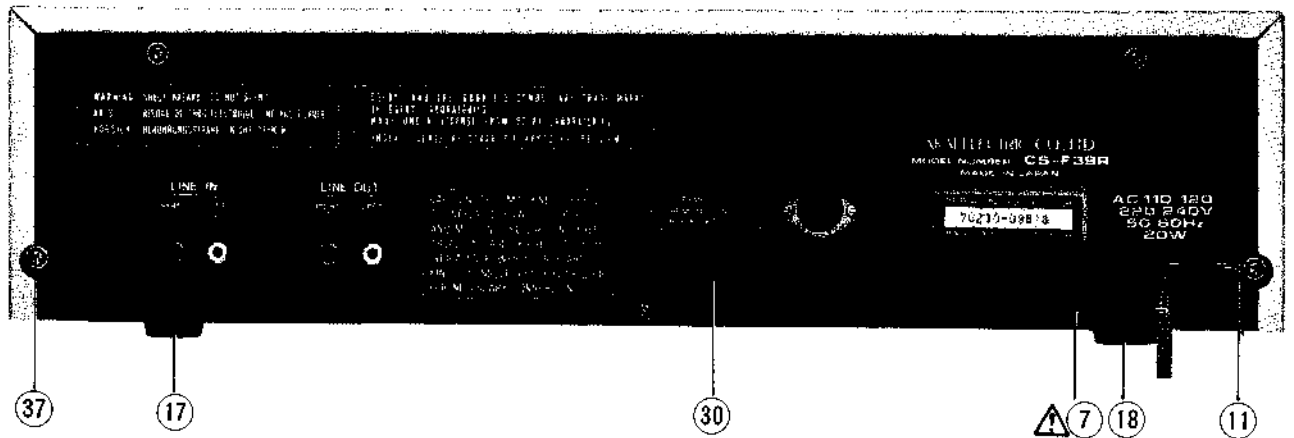
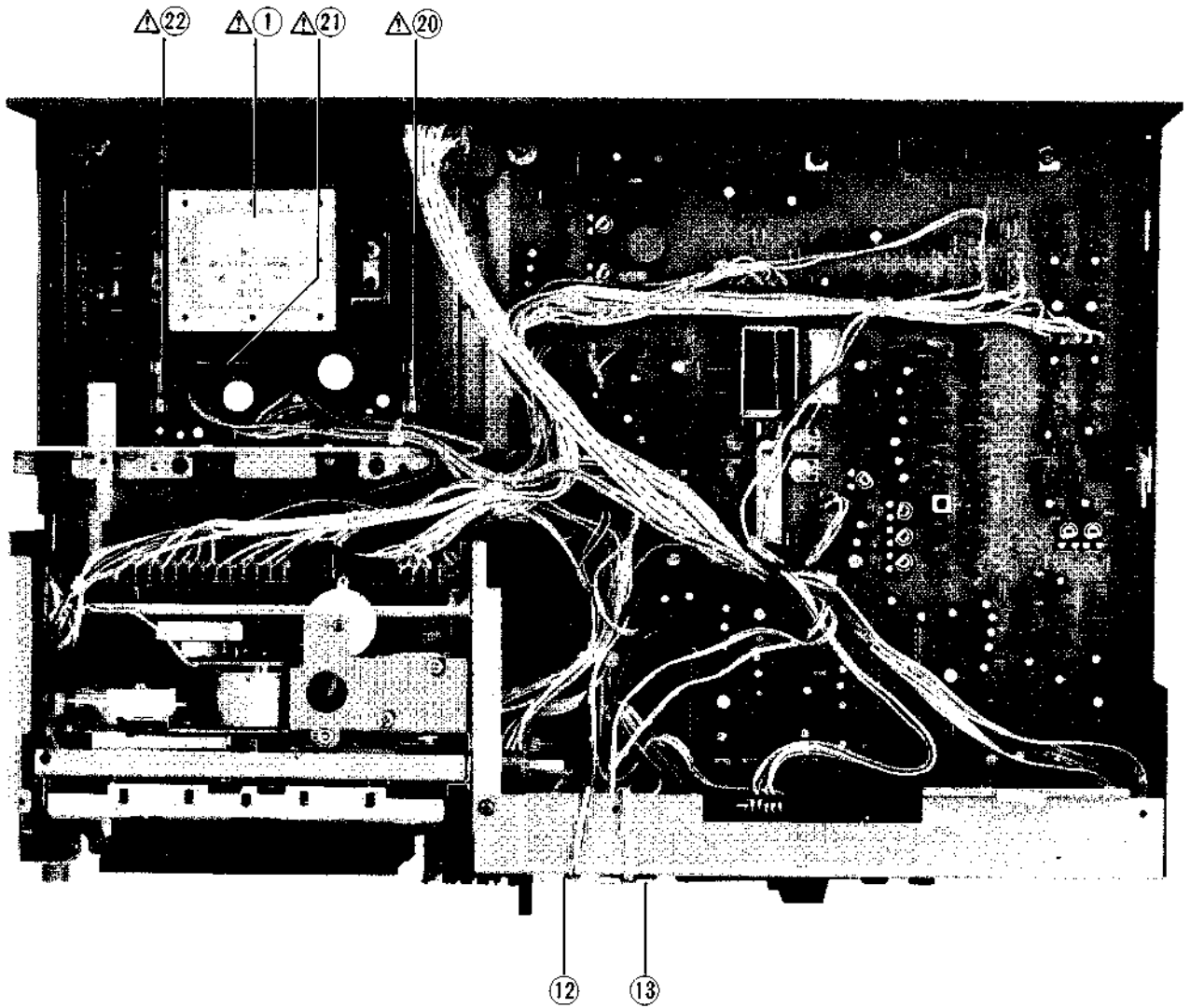

8. ASSEMBLY BLOCK

REF. NO.	PARTS NO.	DESCRIPTION
POWER BLOCK		
8-1	BT-311464	△ TRANS POWER CLT-11 (U)
8-2x	BT-311470	△ TRANS POWER CLT-12 (J)
8-3x	BT-311505	△ TRANS POWER CLT-15 (C)
8-4x	BT-311475	△ TRANS POWER CLT-14 (A)
8-5x	BT-311488	△ TRANS POWER CLT-13 (E,V)
8-6x	BT-311494	△ TRANS POWER CLT-16 (B,S)
8-7	EW-306428	△ AC CORD 2 CORES KP-205A, VFF J (U)
8-8x	EW-306427	△ AC CORD 2 CORES KP-211, VFF J (J)
8-9x	EW-305691	△ AC CORD 2 CORES KP-8, SPT-1 UC (C,A)
8-10x	EW-201796	△ AC CORD 2 CORES KP-419C, LTCE-2F E (E)
8-11	SZ-631945	STRAIN RELIEF SR-4N-4(U,J,C,A,E)
D LED (REV) BLOCK		
8-12	ED-337010	D LED SLF-201C GRN (D1)
D LED (FWD) BLOCK		
8-13	ED-337010	D LED SLF-201C GRN (D2)
ASSEMBLY BLOCK		
8-14x	ZW-312121	RV NYL26x042 BL
8-15x	ZW-231030	RV NYL30x045 BL
8-16x	EV-338033	VR SLIDE 100PIWV0A A104
8-17	SA-202118	FOOT
8-18	SA-313811	RUBBER FOOT
8-19x	ZW-231030	RV NYL30x045 BL
8-20	EF-311839	△ FUSE TSC A 250V 1.6A (F1) (U,J)
8-21	EF-306949	△ FUSE TSC A 250V 1.25A (F2) (U,J)
8-22	EF-309389	△ FUSE TSC A 250V 0.40A (F3) (U,J)
8-23x	EF-308847	△ FUSE TSC 125V 1.60A(F1)(C,A)
8-24x	EF-309392	△ FUSE TSC 125V 1.25A(F2)(C,A)
8-25x	EF-308848	△ FUSE TSC 125V 0.40A(F3)(C,A)
8-26x	EF-601964	△ FUSE SEMKO T 250V 1.60A (F1) (E,B,S,V)
8-27x	EF-602550	△ FUSE SEMKO T 250V 1.25A (F2) (E,B,S,V)
8-28x	EF-668474	△ FUSE SEMKO T 250V 0.40A (F3) (E,B,S,V)
8-29x	EF-602550	△ FUSE SEMKO T 250V 1.25A (F4) (E,B,S,V)
8-30	SP-342039G	PANEL REAR BOARD CS-F39R(U)
8-31x	SP-342039F	PANEL REAR BOARD CS-F39R (J)
8-32x	SP-342039E	PANEL REAR BOARD CS-F39R (C)
8-33x	SP-342039D	PANEL REAR BOARD CS-F39R (A)
8-34x	SP-342039C	PANEL REAR BOARD CS-F39R (E)
8-35x	SP-342039A	PANEL REAR BOARD CS-F39R(B,S)
8-36x	SP-342039B	PANEL REAR BOARD CS-F39R (V)
8-37	ZS-225134	T2PAN30x10STL CMT PW080
8-38x	ZW-305013	RV POP32 (A)
8-39x	EW-322400	△ AC CORD 2 CORES GTBS-2F/KS-15 B (B)
8-40x	EW-322401	△ AC CORD 2 CORES KP-560/S-15 S (S)
8-41x	EW-315767	△ AC CORD 2 CORES KP-419C/KS-15 E (V)

FINAL ASSEMBLY BLOCK

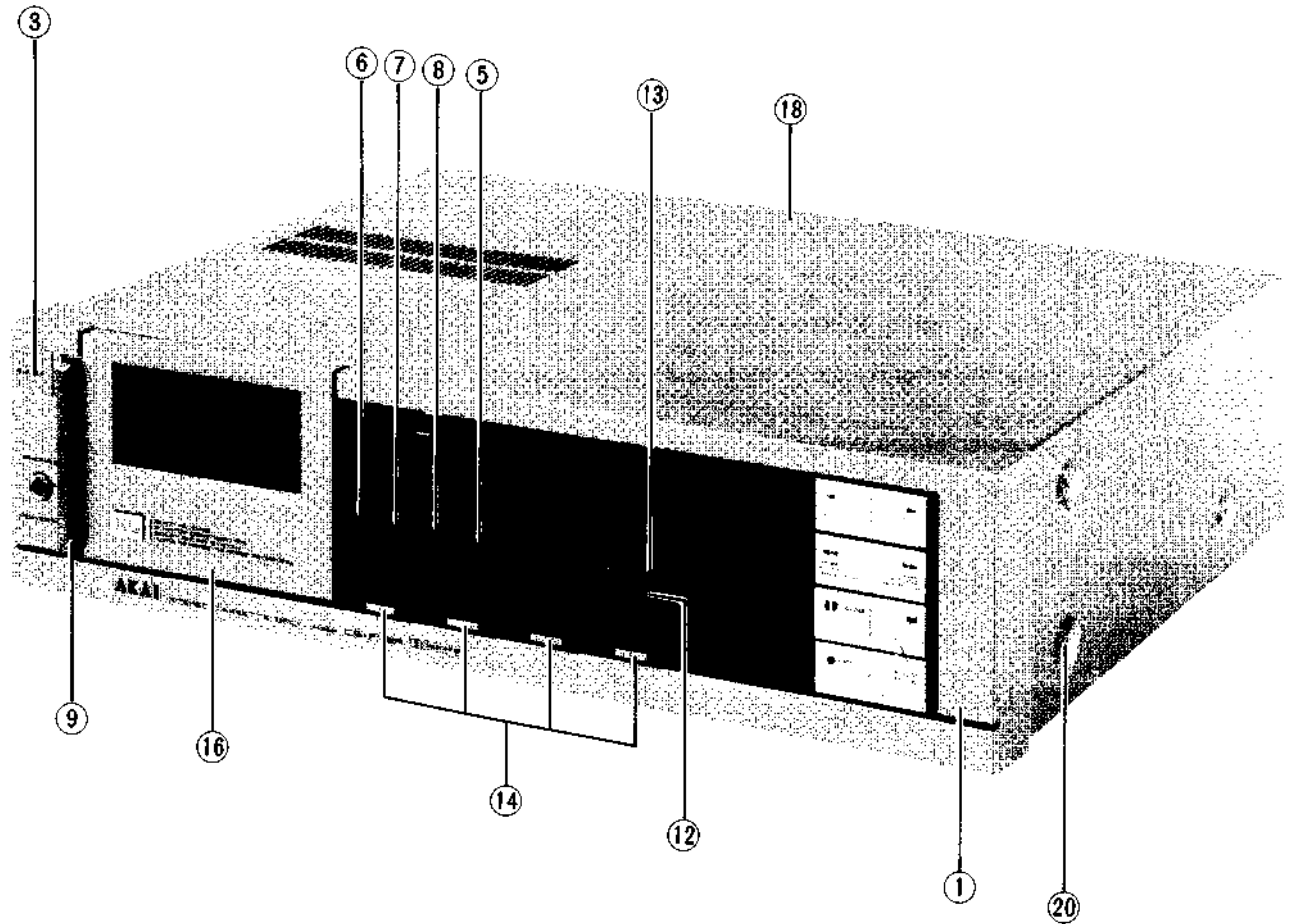

9. FINAL ASSEMBLY BLOCK

REF. NO.	PARTS NO.	DESCRIPTION
PANEL FRONT BLOCK		
9-1	BD-T2041A200A	PANEL FRONT BLK CS-F39R
9-2x	BD-T2041A200B	PANEL FRONT BLK CS-F39R-P
9-3	SK-342041A	KNOB EJECT
9-4x	SK-342041B	KNOB EJECT-P
9-5	SZ-342042	MASK
9-6	SK-342046	KNOB DOLBY (1)
9-7	SK-342047A	KNOB DOLBY (2)
9-8	SK-342047B	KNOB DOLBY (3)
9-9	SK-342040A	KNOB POWER
9-10x	SK-342040B	KNOB POWER-P
9-11x	ZG-342051	SP RETURN
FINAL ASSEMBLY BLOCK		
9-12	SK-342056A	KNOB VR
9-13	SK-342056B	KNOB VR (B)
9-14	SK-342050A	KNOB SLIDE
9-15x	SK-342050B	KNOB SLIDE-P
9-16	BD-B342048A	LID PANEL PART
9-17x	BD-B342048B	LID PANEL-P PART
9-18	SP-332003D	COVER UPPER (C)
9-19x	SP-332003E	COVER UPPER (C)-P
9-20	ZS-341963	XST BID40x06STL NI3
9-21x	ZS-341964	XST BID40x06STL BNI
9-22x	SP-342721	CASE WOOD (CS-F39R-W)
9-23x	ZW-548010	SPOT FACING WASHER
		(CS-F39R-W)
9-24x	ZS-342736	ST BID40x20STL BNI (CS-F39R-W)

When ordering parts, please quote Parts Number, Description and Model Number.

INDEX

1. MODEL CS-F36R

PARTS NO.	REF. NO.	PARTS NO.	REF. NO.	PARTS NO.	REF. NO.	PARTS NO.	REF. NO.
BA-T2042A080A	5-1	EI-336761	4-IC2	ET-328437	5-TR13	ZG-310531	3-32
BA-T2042A090A	4-1	EI-605013	4-IC1	ET-328438	5-TR14	ZG-310694	3-36
BA-T2042A090B	4-2	EJ-283140	6-VS1	ET-328438	5-TR16	ZG-310695	3-37
BD-B342025	3-50	EJ-310567	6-J1	ET-328868	4-TR24	ZG-312921	1-23
BD-B342048C	9-16	EJ-311843	6-J2	ET-328868	4-TR21	ZG-312942	3-24
BD-B342048D	9-17x	EJ-331215	4-J1	ET-328868	4-TR12	ZG-312944	3-19
BD-T2042A100A	9-1	EJ-332109	4-J1	ET-328868	4-TR26,27	ZG-312946	1-22
BD-T2042A100B	9-2x	EJ-332435	4-J2	ET-328868	4-TR9,10	ZG-313314	1-14
BH-T2042A130A	1-1x	EJ-332437	4-J2	ET-338081	4-TR30	ZG-313316	1-10
BI-312117	2-10	EJ-336885	3-1	ET-402682	6-TR3	ZG-313874	1-11
BI-312118	2-22	EJ-336886	3-2x	ET-603257	4-TR2,3	ZG-313960	1-17
BL-T2041A110A	3-14	EM-332427	7-IN1	EV-315540	4-VR4	ZG-314747	2-8
BL-T2041A120A	3-16	EO-311974	4-T1	EV-315542	4-VR11	ZG-314749	2-24
BM-T2016A320A	2-1	EO-316140	4-L3	EV-315753	4-VR5	ZG-314876	2-23
BM-T2022A080A	3-8	EO-321336	4-VL1	EV-322411	4-VR10	ZG-318083	3-31
BM-314843	3-9	EO-330239	4-L1	EV-322415	4-VR1,2	ZG-318204	3-18
BM-328441	2-2	EO-669273	3-13x	EV-322417	4-VR3	ZG-321487	3-49
BR-328424	2-14	EO-669273	4-L2	EV-336785	4-VR6to9	ZG-321534	2-18
BT-311464	8-1	EO-669273	5-L1	EV-338033	8-16x	ZG-324329	3-47
BT-311470	8-2x	EP-318644	3-7	EV-522652	5-VR1	ZG-328305	1-7
BT-311475	8-4x	EP-318645	2-4	EW-201796	8-10x	ZG-328366	2-12
BT-311488	8-5x	EP-318648	4-RL1	EW-305691	8-9x	ZG-330049	2-13
BT-311494	8-6x	ER-200595	4-FR2,3	EW-306427	8-8x	ZG-330078	1-16
BT-311505	8-3x	ER-318647	4-FR1	EW-306428	8-7	ZG-332040	3-43
BZ-T2016A290A	3-46	ER-321251	4-R119	EW-315767	8-41x	ZG-336063	3-39
BZ-T2016A330A	2-20	ER-323996	4-FJ09	EW-322400	8-39x	ZG-336064	3-45
BZ-T2016A330A	3-30	ER-328490	4-FL2	EW-322401	8-40x	ZG-336651	3-23
BZ-T2022A260A	2-19	ER-328491	4-FL1	EZ-328406	5-X1	ZG-342051	9-10x
BZ-T2041A100A	1-15	ER-331627	4-R112	HE-325859	1-9	ZG-369088	1-2
EC-306022	4-C54	ES-311975	4-SW1	HP-311634	1-5	ZG-402895	1-3
EC-306438	5-C10	ES-312234	6-SW1	HZ-313313	1-13	ZS-225134	8-37
EC-306980	5-C9	ES-312235	6-SW1	HZ-314069	3-25x	ZS-302318	3-29
EC-307494	4-C76	ES-312238	6-SW1	MB-282104	2-17	ZS-321338	3-12
EC-310440	4-C4	ES-328415	4-SW2	MB-282778	3-11	ZS-341963	9-20
EC-320548	6-C1	ES-330463	3-3	MB-314317	3-28	ZS-341964	9-21x
EC-324921	4-C59	ES-330521	3-5	MB-342028	3-38	ZS-430413	2-7
EC-324921	4-C55	ES-330522	3-6	MC-342355	3-4	ZS-465298	1-4
EC-325380	4-C72	ES-336780	4-SW1to8	MH-314340	1-21	ZS-479474	2-21
EC-330308	6-C1	ES-337322	4-SW1	MI-B601782	3-26	ZS-592378	1-8
EC-330308	6-C1	ES-337322	4-SW1	MI-B601783	3-27	ZS-608106	1-6
EC-334071	4-C2	ES-338170	4-SW1,2	ML-314337	3-33	ZW-231030	8-15x
EC-334072	4-C86	ET-200505	4-TR31to35	ML-314384	3-41	ZW-231030	8-19x
EC-337966	4-C70	ET-200505	4-TR39	ML-314404	3-40	ZW-270088	1-19
ED-301911	4-D16to18	ET-200505	4-TR13to20	ML-332039	3-42	ZW-270088	2-9
ED-301911	4-D4to7	ET-200505	4-TR37	MP-B342026	3-15	ZW-270088	3-44
ED-301911	4-D12to14	ET-200505	4-TR6,7	MR-314339	3-34	ZW-273745	2-6
ED-301911	4-D9,10	ET-200505	4-TR22,23	MR-328360	2-3	ZW-305013	8-38x
ED-301911	4-D20to22	ET-200505	4-TR42	MR-328479	3-10	ZW-312121	8-14x
ED-306109	4-D8	ET-200505	4-TR29	MS-302191	3-20	ZW-330073	2-15
ED-306109	5-D5	ET-200558	4-TR8	MT-305793	2-16	ZW-516993	2-5
ED-306109	5-D1to3	ET-200558	5-TR5	MV-269965	3-35	ZW-556828	1-18
ED-308952	5-D13,14	ET-200558	5-TR25,26	MV-328322	3-21	ZW-618884	1-12
ED-309341	4-D1to3	ET-200558	5-TR21	MV-357208	1-20		
ED-318859	4-D15	ET-200558	5-TR38	SA-202118	8-17		
ED-319167	6-D4	ET-200985	5-TR33,34	SA-313811	8-18		
ED-329449	6-D3	ET-200985	5-TR4	SK-341957	9-11		
ED-330987	6-D1,2	ET-200985	5-TR22to24	SK-342040A	9-8		
ED-331198	4-D19	ET-200985	5-TR27to31	SK-342040B	9-9x		
ED-337010	3-17	ET-200985	5-TR8	SK-342041A	9-3		
ED-337010	8-12	ET-200985	5-TR17to20	SK-342041B	9-4x		
ED-337010	8-13	ET-200985	5-TR36,37	SK-342047B	9-6		
ED-337014	4-D1	ET-200985	5-TR1	SK-342047C	9-7		
ED-337091	4-D1to3	ET-200985	5-TR12	SK-342050A	9-14		
ED-337092	4-D4,5	ET-200985	6-TR2	SK-342050B	9-15x		
ED-337195	4-D2	ET-200985	6-TR4	SK-342056A	9-12		
ED-560913	5-D9to12	ET-200985	6-TR6	SK-342056B	9-13		
ED-560913	5-D13to19	ET-307349	6-TR1	SP-332003D	9-18		
ED-560913	5-D22	ET-307349	6-TR5	SP-332003E	9-19x		
EF-306949	8-21	ET-309353	4-TR5	SP-342039H	8-35x		
EF-308847	8-23x	ET-309353	5-TR7	SP-342039J	8-36x		
EF-308848	8-25x	ET-309353	5-TR3	SP-342039K	8-34x		
EF-309389	8-22	ET-309353	5-TR11	SP-342039L	8-33x		
EF-309392	8-24x	ET-310148	4-TR28	SP-342039M	8-32x		
EF-311839	8-20	ET-310833	4-TR40,41	SP-342039N	8-31x		
EF-601964	8-26x	ET-311977	4-PH1	SP-342039P	8-30		
EF-602550	8-29x	ET-317919	4-TR38	SZ-342042	9-5		
EF-602550	8-27x	ET-318237	5-TR2	SZ-631945	8-11		
EF-668474	8-28x	ET-319638	4-TR1	TC-314156	3-22		
EI-311710	5-IC1	ET-319638	4-TR4	TC-328351	3-48		
EI-315799	7-IC1	ET-328437	5-TR15	TC-328365	2-11		

INDEX

2. MODEL CS-F39R

PARTS NO.	REF. NO.	PARTS NO.	REF. NO.	PARTS NO.	REF. NO.	PARTS NO.	REF. NO.
BA-T2041A140A	5-1	EI-311710	5-IC1	ET-328437	4-TR1	SZ-631945	8-11
BA-T2041A150A	4-1	EI-315799	7-IC1	ET-328437	4-TR13	TC-314156	3-22
BA-T2041A150B	4-2	EI-336761	4-IC2,3	ET-328437	5-TR13	TC-328351	3-48
BD-B342025	3-50	EI-336983	4-IC1	ET-328437	5-TR15	TC-328365	2-11
BD-B342048A	9-16	EJ-283140	6-VS1	ET-328438	5-TR16	ZG-310531	3-32
BD-B342048B	9-17x	EJ-310567	6-J1	ET-328438	5-TR14	ZG-310694	3-36
BD-T2041A200A	9-1	EJ-311843	6-J2	ET-328868	4-TR29	ZG-310695	3-37
BD-T2041A200B	9-2x	EJ-331215	4-J1	ET-328868	4-TR26	ZG-312921	1-23
BH-T2041A090A	1-1x	EJ-332109	4-J1	ET-328868	4-TR10,11	ZG-312942	3-24
BI-312117	2-10	EJ-332435	4-J2	ET-338081	4-TR33	ZG-312944	3-19
BI-312118	2-22	EJ-332437	4-J2	ET-402682	6-TR3	ZG-312946	1-22
BL-T2041A110A	3-14	EJ-336885	3-1	ET-603257	4-TR2,3	ZG-313314	1-14
BL-T2041A120A	3-16	EJ-336886	3-2x	ET-603257	4-TR12	ZG-313316	1-10
BM-T2016A320A	2-1	EM-332427	7-IN1	ET-603257	4-TR41	ZG-313874	1-11
BM-T2022A080A	3-8	EO-311974	4-T1	EV-315540	4-VR12	ZG-313960	1-17
BM-314843	3-9	EO-316140	4-L3	EV-315542	4-VR11	ZG-314747	2-8
BM-328441	2-2	EO-321336	4-VL1	EV-315753	4-VR5	ZG-314749	2-24
BR-328424	2-14	EO-330239	4-L1	EV-322411	4-VR10	ZG-314876	2-23
BT-311464	8-1	EO-337044	4-FL1	EV-322415	4-VR1,2	ZG-318083	3-31
BT-311470	8-2x	EO-669273	3-13x	EV-322417	4-VR3	ZG-318204	3-18
BT-311475	8-4x	EO-669273	4-L2	EV-336785	4-VR6to9	ZG-321487	3-49
BT-311488	8-5x	EO-669273	5-L1	EV-338033	8-16x	ZG-321534	2-18
BT-311494	8-6x	EP-318644	3-7	EV-522652	5-VR1	ZG-324329	3-47
BT-311505	8-3x	EP-318645	2-4	EW-201796	8-10x	ZG-328305	1-7
BZ-T2016A290A	3-46	EP-318648	4-RL1	EW-305691	8-9x	ZG-328366	2-12
BZ-T2016A330A	2-20	ER-200595	4-FR2,3	EW-306427	8-8x	ZG-330049	2-13
BZ-T2016A330A	3-30	ER-318647	4-FR1	EW-306428	8-7	ZG-330078	1-16
BZ-T2022A260A	2-19	ER-321251	4-R143	EW-315767	8-41x	ZG-332040	3-43
BZ-T2041A100A	1-15	ER-333668	4-R132	EW-322400	8-39x	ZG-336063	3-39
EC-306018	4-C81	ER-336775	4-FL3	EW-322401	8-40x	ZG-336064	3-45
EC-306022	4-C71	ER-336776	4-FL2	EZ-328406	5-X1	ZG-336651	3-23
EC-306438	5-C10	ES-311975	4-SW1	HE-325859	1-9	ZG-342051	9-11x
EC-306980	5-C9	ES-312234	6-SW1	HP-311634	1-5	ZG-369088	1-2
EC-308142	4-C3	ES-312235	6-SW1	HZ-313313	1-13	ZG-402895	1-3
EC-316570	4-C72,73	ES-312238	6-SW1	HZ-314069	3-25x	ZS-225134	8-37
EC-320548	6-C1	ES-330463	3-3	MB-282104	2-17	ZS-302318	3-29
EC-325380	4-C74	ES-330463	5-SW1	MB-282778	3-11	ZS-321338	3-12
EC-330308	6-C1	ES-330521	3-5	MB-314317	3-28	ZS-341963	9-20
EC-330308	6-C1	ES-330522	3-6	MB-342028	3-38	ZS-341964	9-21x
EC-334071	4-C1	ES-336780	4-SW1to8	MC-342319	3-4	ZS-342736	9-24x
EC-334211	4-C100	ES-337322	4-SW1	MH-314340	1-21	ZS-430413	2-7
EC-337966	4-C76	ES-337322	4-SW1	MI-B601782	3-26	ZS-465298	1-4
ED-200468	5-D20,21	ES-338036	4-SW1to3	MI-B601783	3-27	ZS-479474	2-21
ED-301911	4-D4	ET-200505	4-TR31,32	ML-314337	3-33	ZS-592378	1-8
ED-301911	4-D8,9	ET-200505	4-TR23to25	ML-314384	3-41	ZS-608106	1-6
ED-301911	4-D17to20	ET-200505	4-TR34to36	ML-314404	3-40	ZW-231030	8-19x
ED-301911	4-D15	ET-200505	4-TR38,39	ML-332039	3-42	ZW-231030	8-15x
ED-301911	4-D11to13	ET-200505	4-TR42	MP-B342026	3-15	ZW-270088	1-19
ED-301911	4-D22to24	ET-200505	4-TR27,28	MR-314339	3-34	ZW-270088	2-9
ED-306109	5-D5	ET-200505	4-TR14to20	MR-328360	2-3	ZW-270088	3-44
ED-306109	5-D1to3	ET-200505	4-TR4	MR-328479	3-10	ZW-273745	2-6
ED-308952	5-D13,14	ET-200505	4-TR6to8	MS-302191	3-20	ZW-305013	8-38x
ED-309341	4-D2,3	ET-200558	4-TR9	MT-305793	2-16	ZW-312121	8-14x
ED-319167	6-D4	ET-200558	5-TR38	MV-269965	3-35	ZW-330073	2-15
ED-329449	6-D3	ET-200558	5-TR5	MV-328322	3-21	ZW-516993	2-5
ED-330987	6-D1,2	ET-200558	5-TR21	MV-357208	1-20	ZW-548010	9-23x
ED-337010	3-17	ET-200558	5-TR25,26	SA-202118	8-17	ZW-556828	1-18
ED-337010	8-12	ET-200985	4-TR43	SA-313811	8-18	ZW-618884	1-12
ED-337010	8-13	ET-200985	5-TR8	SK-342040A	9-9		
ED-337014	4-D1	ET-200985	5-TR1	SK-342040B	9-10x		
ED-337091	4-D11to3	ET-200985	5-TR12	SK-342041A	9-3		
ED-337092	4-D4to6	ET-200985	5-TR27to31	SK-342041B	9-4x		
ED-337195	4-D2	ET-200985	5-TR17to20	SK-342046	9-6		
ED-338082	4-D1	ET-200985	5-TR4	SK-342047A	9-7		
ED-338083	4-D10	ET-200985	5-TR33to37	SK-342047B	9-8		
ED-338342	4-D21	ET-200985	5-TR22to24	SK-342050A	9-14		
ED-338454	4-D14	ET-200985	6-TR6	SK-342050B	9-15x		
ED-560913	5-D22	ET-200985	6-TR2	SK-342056A	9-12		
ED-560913	5-D9to12	ET-200985	6-TR4	SK-342056B	9-13		
ED-560913	5-D15to19	ET-307349	6-TR5	SP-332003D	9-18		
EF-306949	8-21	ET-307349	6-TR1	SP-332003E	9-19x		
EF-308847	8-23x	ET-309353	4-TR21,22	SP-342039A	8-35x		
EF-308848	8-25x	ET-309353	5-TR3	SP-342039B	8-36x		
EF-309389	8-22	ET-309353	5-TR7	SP-342039C	8-34x		
EF-309392	8-24x	ET-309353	5-TR11	SP-342039D	8-33x		
EF-311839	8-20	ET-310148	4-TR30	SP-342039E	8-32x		
EF-601964	8-26x	ET-311977	4-PH1	SP-342039F	8-31x		
EF-602550	8-27x	ET-317919	4-TR40	SP-342039G	8-30		
EF-602550	8-29x	ET-318237	5-TR2	SP-342721	9-22x		
EF-668474	8-28x	ET-318239	4-TR5	SZ-342042	9-5		

SECTION 3

SCHEMATIC DIAGRAM

1. SCHEMATIC DIAGRAM OF ICs	66
2. CS-F36R POWER & SYSCON NO. 2-1 1641012A SCHEMATIC DIAGRAM ...	69
3. CS-F36R AMP NO. 2-2 1641013A SCHEMATIC DIAGRAM	70
4. CS-F39R POWER & SYSCON NO. 2-1 1641014A SCHEMATIC DIAGRAM ...	71
5. CS-F39R AMP NO. 2-2 1641015A SCHEMATIC DIAGRAM	72

HA12019

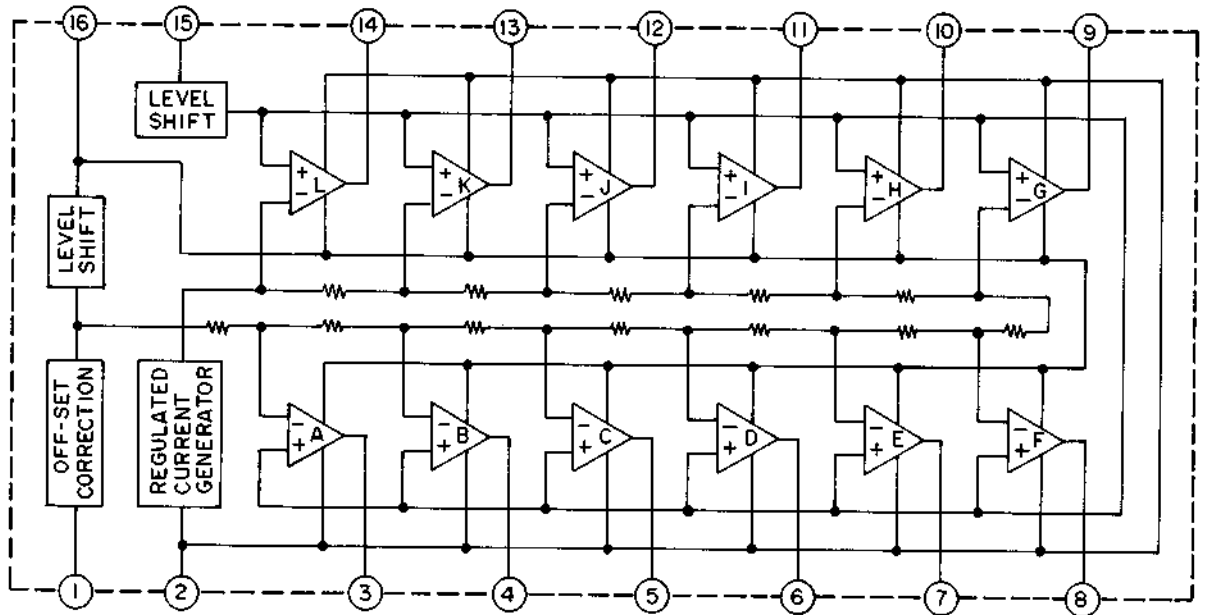

HA12038

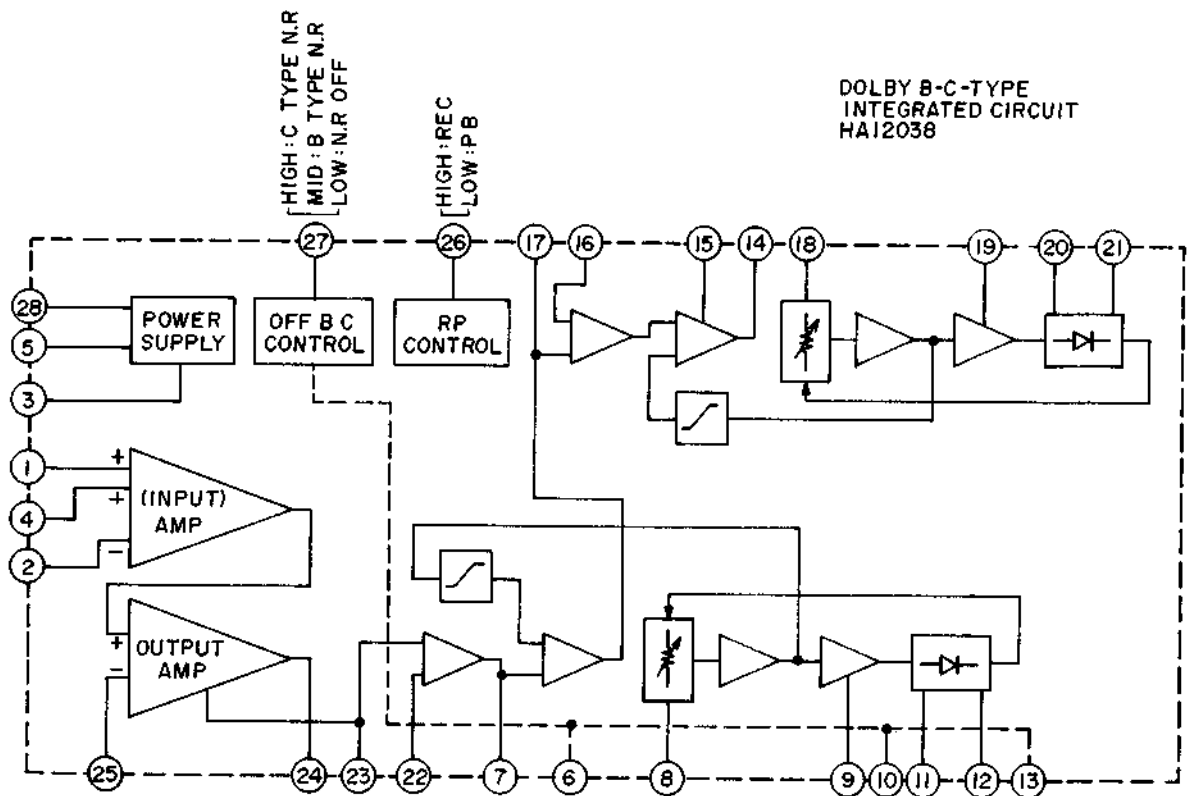

DOLBY B-C-TYPE
INTEGRATED CIRCUIT
HA12038

LA6458S

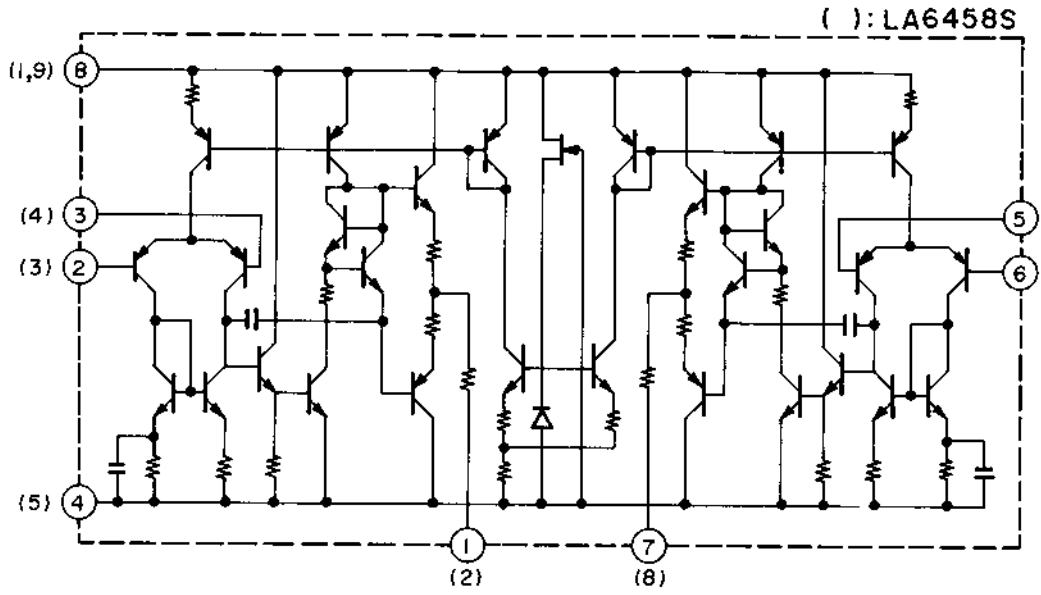

LM6402A-028

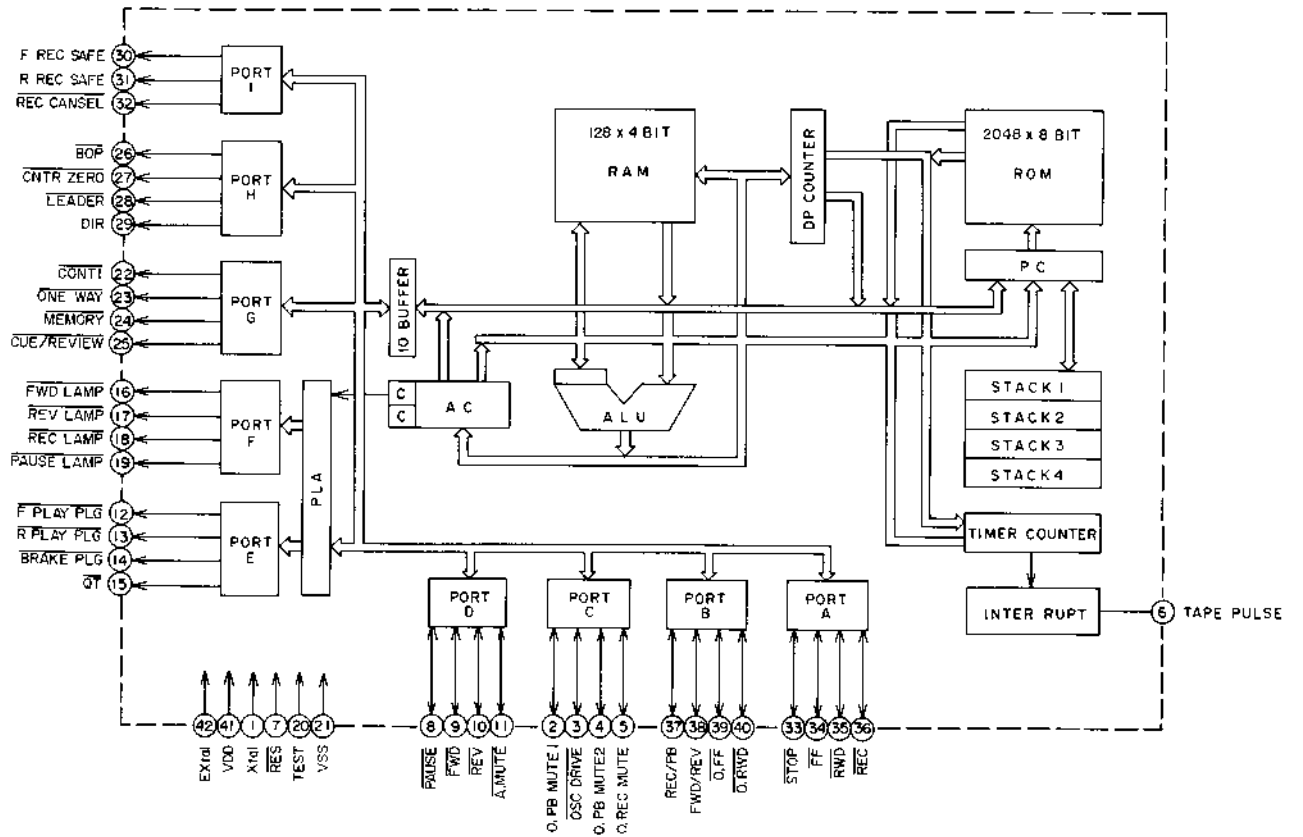

NE545B

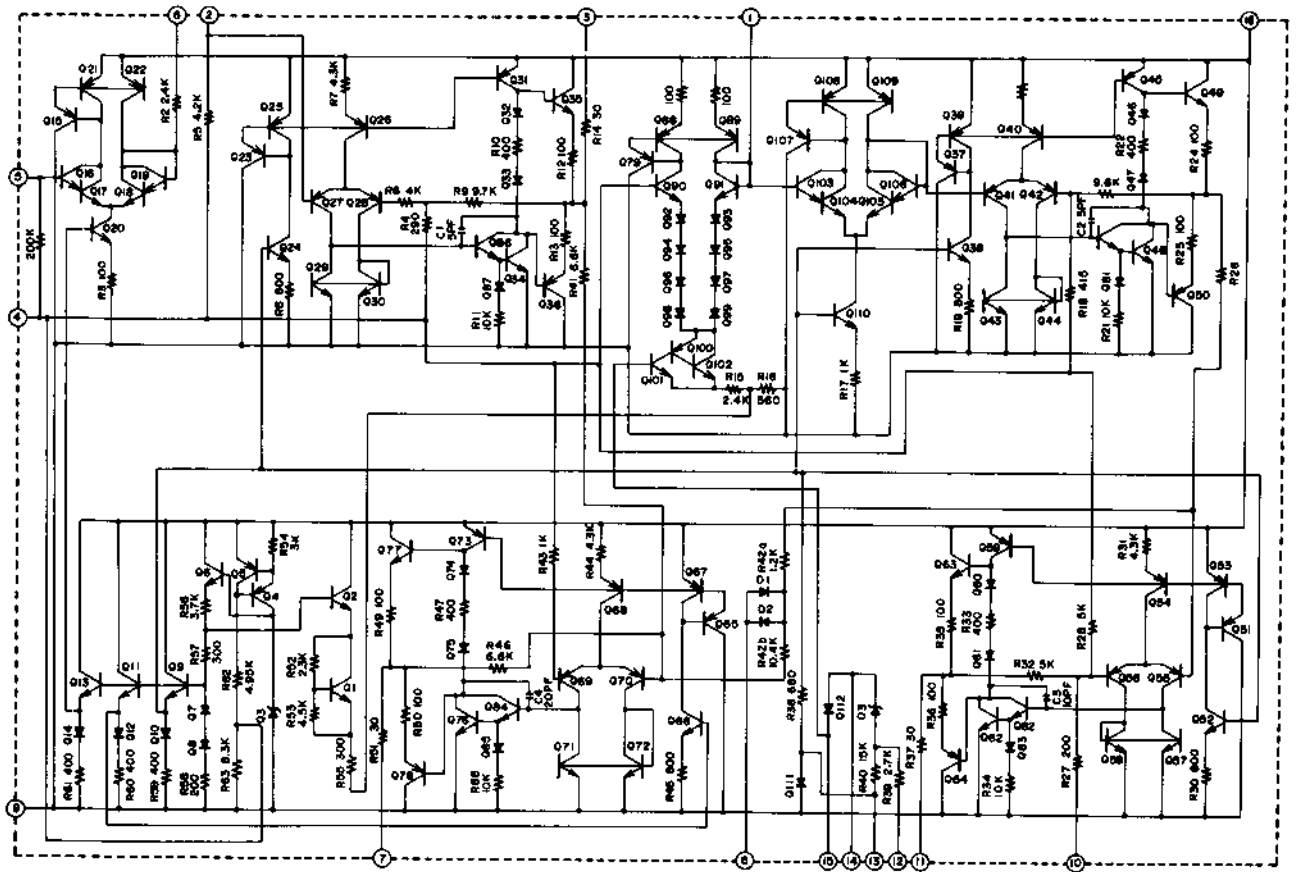

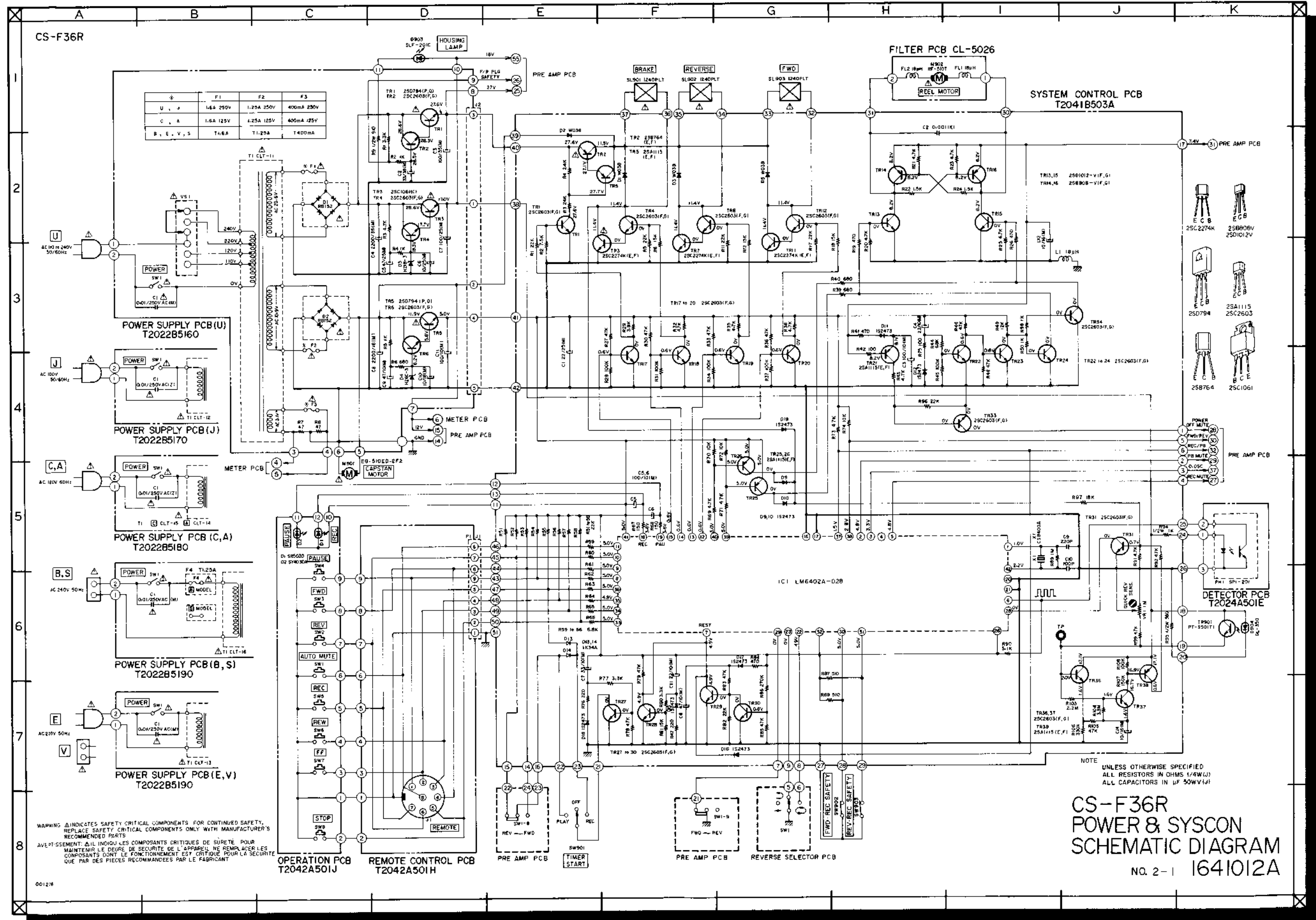

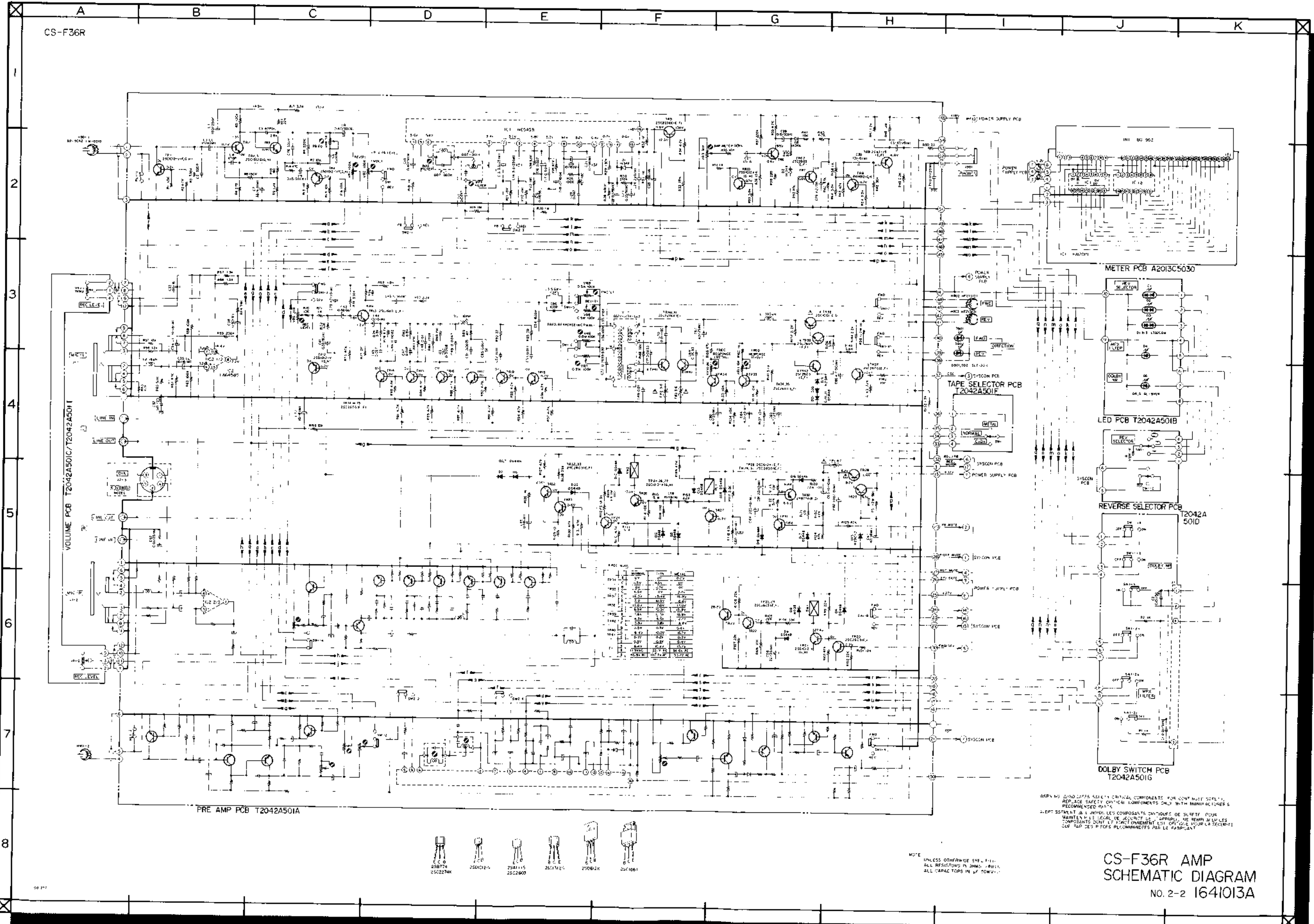

CS-F36R

1
2
3
4
5
6
7
8

VOLUME PCB T2042A501C/T2042A501I

PRE AMP PCB T2042A501A

TAPE SELECTOR PCB T2042A501F

METER PCB A2013C5030

LED PCB T2042A501B

REVERSE SELECTOR PCB T2042A501D

DOLBY SWITCH PCB T2042A501G

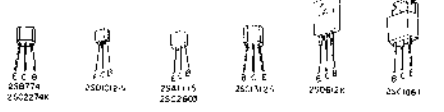

NOTE
UNLESS OTHERWISE SPECIFIED,
ALL RESISTORS IN OHMS - 100K,
ALL CAPACITORS IN MICROFARADS.

CS-F36R AMP
SCHEMATIC DIAGRAM
NO. 2-2 1641013A

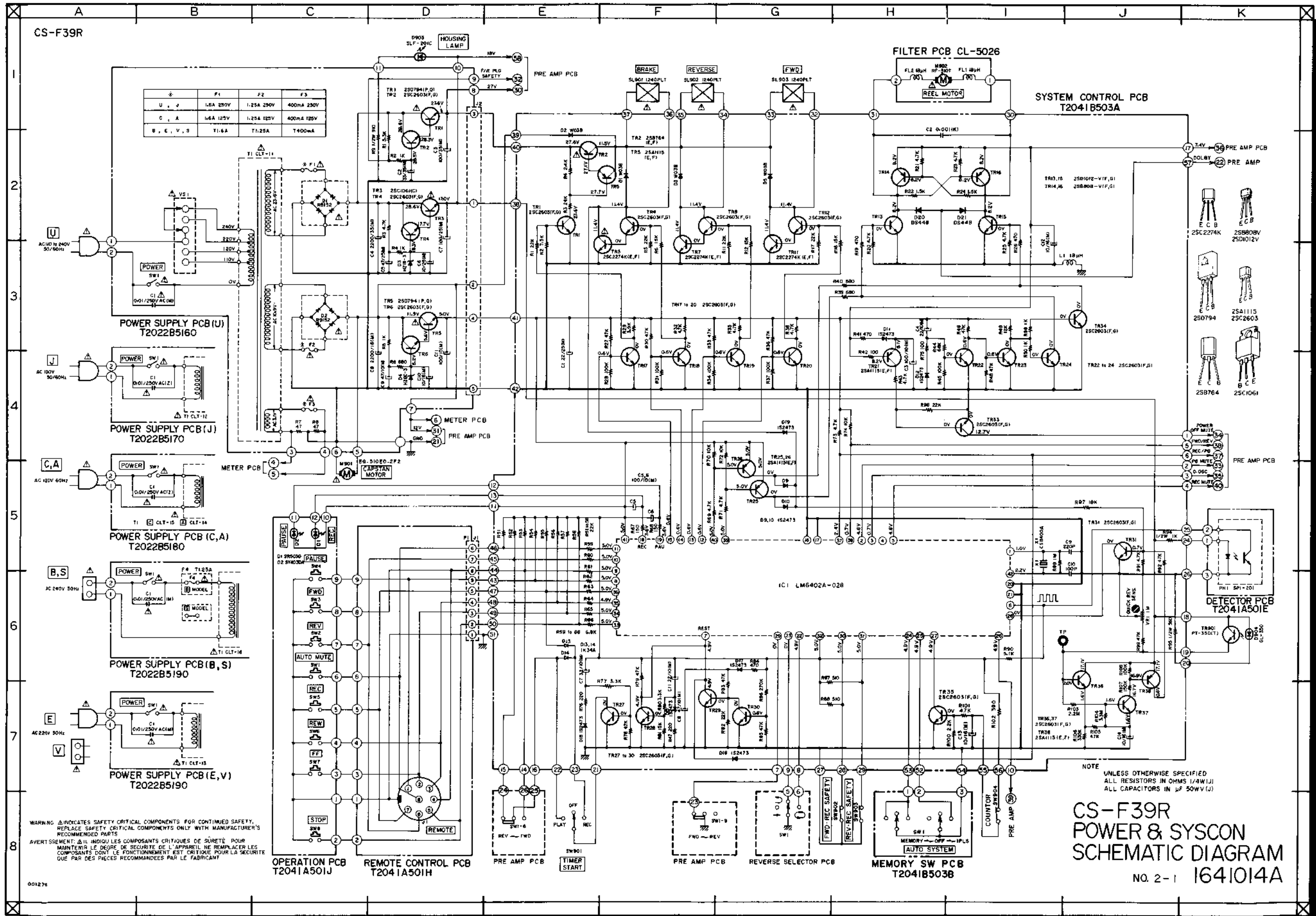

CS-F39R

F1	F2	F3
1.5A 250V	1.25A 250V	400mA 250V
1.6A 125V	1.25A 125V	400mA 125V
T1.6A	T1.25A	T400mA

WARNING: Δ INDICATES SAFETY CRITICAL COMPONENTS FOR CONTINUED SAFETY. REPLACE SAFETY CRITICAL COMPONENTS ONLY WITH MANUFACTURER'S RECOMMENDED PARTS.
 AVERTISSEMENT: Δ IL INDIQUE LES COMPOSANTS CRITIQUES DE SÛRETÉ POUR MAINTENIR LE DEGRÉ DE SÛRETÉ DE L'APPAREIL. NE REMPLACER LES COMPOSANTS DONT LE FONCTIONNEMENT EST CRITIQUE POUR LA SÛRETÉ QUE PAR DES PIÈCES RECOMMANDÉES PAR LE FABRICANT.

NOTE: UNLESS OTHERWISE SPECIFIED, ALL RESISTORS IN OHMS (1/4W/1/2), ALL CAPACITORS IN µF (50V/10V).
CS-F39R
POWER & SYSCON
SCHEMATIC DIAGRAM
 No. 2-1 1641014A

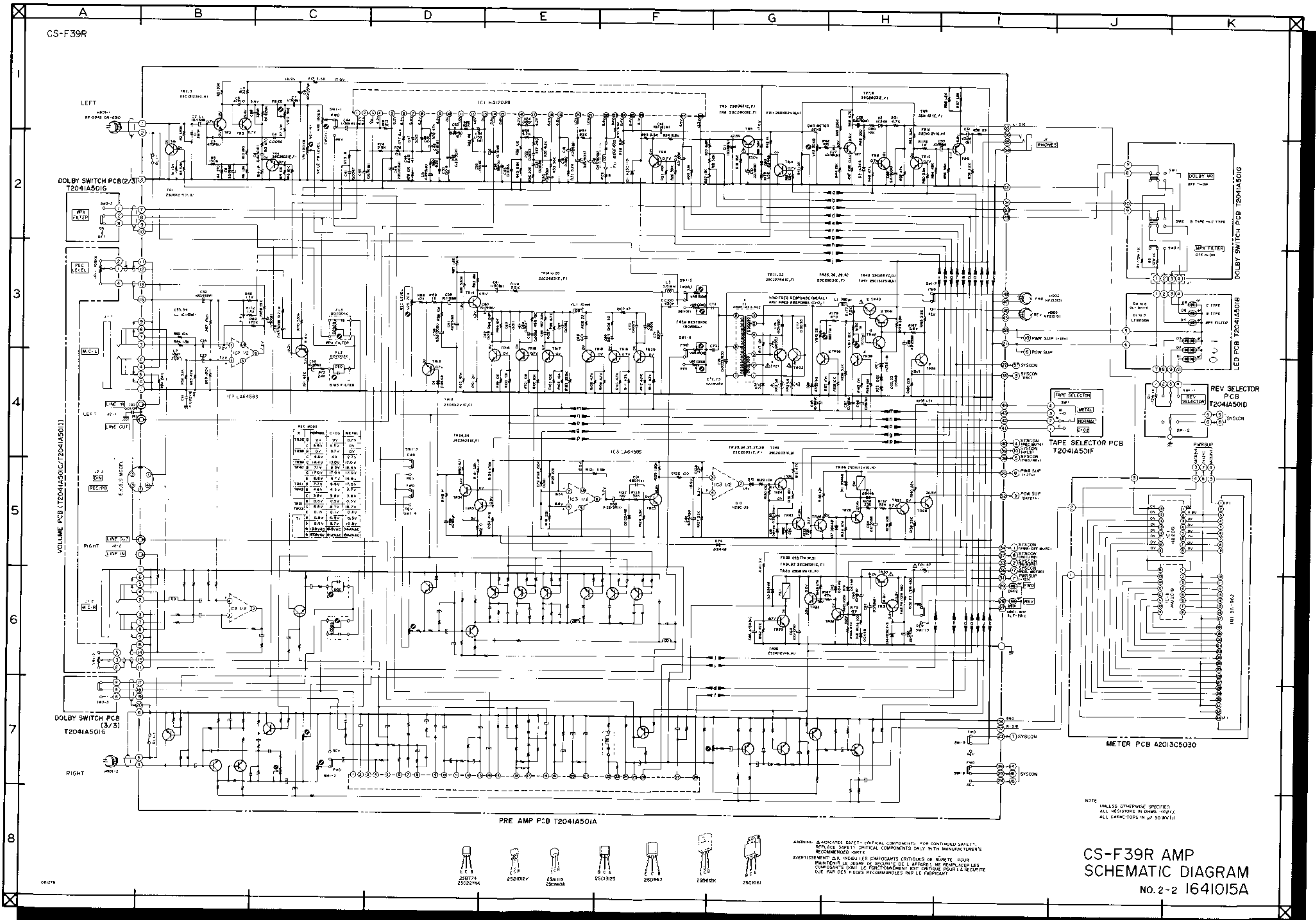

CS-F39R AMP SCHEMATIC DIAGRAM
No. 2-2 1641015A