

AKAI SERVICE MANUAL

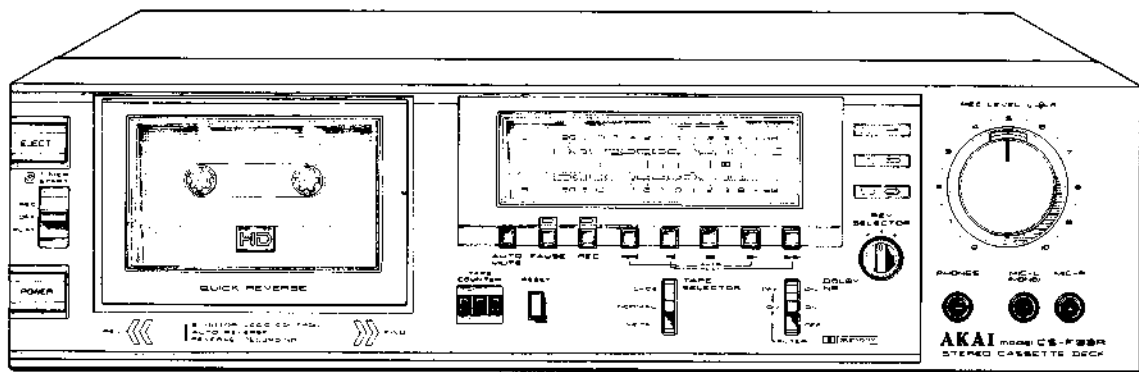

CS - F33R

STEREO CASSETTE DECK

MODEL **CS-F33R**

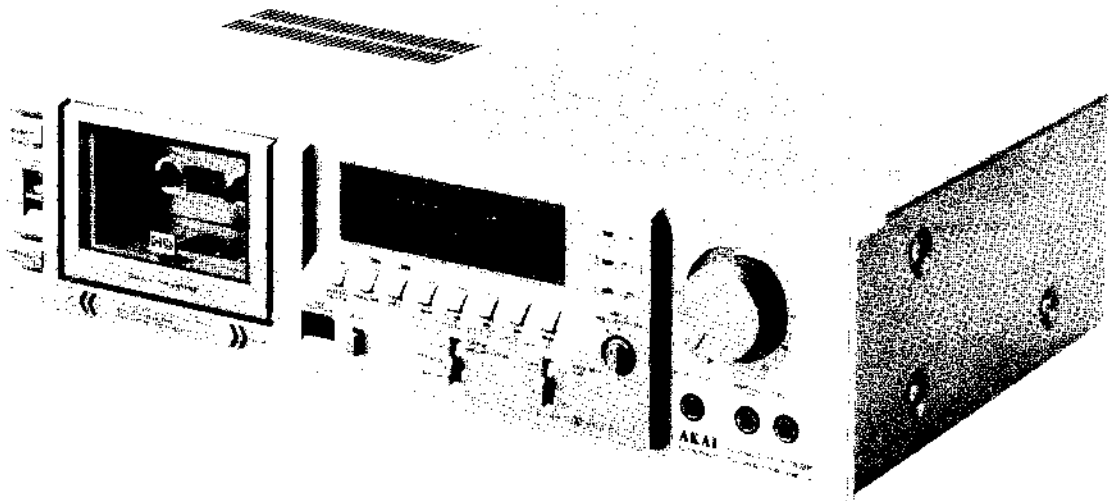

STEREO CASSETTE DECK

MODEL CS-F33R

THIS MANUAL IS APPLICABLE TO BOTH
SILVER AND BLACK PANEL MODELS.

TABLE OF CONTENTS

SECTION 1 SERVICE MANUAL	3
SECTION 2 PARTS LIST	23
SECTION 3 SCHEMATIC DIAGRAM	38

SECTION 1

SERVICE MANUAL

TABLE OF CONTENTS

I.	TECHNICAL DATA	4
II.	DISMANTLING OF UNIT	5
III.	CONTROLS	6
IV.	PRINCIPAL PARTS LOCATION	7
V.	VOLTAGE AND CYCLE CONVERSION	8
	1. VOLTAGE CONVERSION	8
	2. CYCLE CONVERSION	8
VI.	MECHANICAL ADJUSTMENT	9
	1. FLYWHEEL LOOSE PLAY ADJUSTMENT	9
	2. PLUNGER POSITION ADJUSTMENT	10
	3. PINCH ROLLER PRESSURE MEASUREMENT	10
	4. WINDING TORQUE MEASUREMENT IN EACH MODE	10
	5. TAPE SPEED ADJUSTMENT	10
VII.	HEAD ADJUSTMENT	11
	1. ERASE HEAD HEIGHT ADJUSTMENT	11
	2. TAPE GUIDE HEIGHT ADJUSTMENT	11
	3. REC/PB HEAD HEIGHT ADJUSTMENT	11
	4. REC/PB HEAD AZIMUTH ADJUSTMENT	11
VIII.	ELECTRICAL ADJUSTMENT	12
	1. QUICK REVERSE SENSITIVITY ADJUSTMENT	12
	2. AMPLIFIER ADJUSTMENT	12
IX.	DC RESISTANCE OF VARIOUS COILS	14
X.	CLASSIFICATION OF VARIOUS P.C BOARDS	14
	1. P.C BOARD TITLES AND IDENTIFICATION NUMBERS	14
	2. COMPOSITION OF VARIOUS P.C BOARDS	15

For basic adjustments, measuring methods, and operating principles, refer to GENERAL TECHNICAL MANUAL.

I. TECHNICAL DATA

Track System	4 Track 2 Channel Stereo System
Tape	Philips Type Cassette
Tape Speed	4.76 cm/s \pm 1.0% (1-7/8 ips. \pm 1.0%)
Heads	Erase head \times 2 High Density Metallic head for recording/playback \times 1
Motors	Electronically speed controlled DC motor for capstan drive \times 1 DC motor for reel drive \times 1
Wow and Flutter	Less than 0.04% WRMS, 0.12% (DIN 45500)
Tape Winding Time	80 sec. using a C-60 cassette tape
Frequency Response	Normal: 30 to 16,000 Hz \pm 3 dB CrO ₂ : 30 to 16,500 Hz \pm 3 dB (-20 VU) 30 to 8,500 Hz \pm 3 dB (0 VU) Metal: 30 to 18,000 Hz \pm 3 dB (-20 VU) 30 to 12,500 Hz \pm 3 dB (0 VU)
Signal to Noise Ratio	Normal: Better than 58 dB CrO ₂ : Better than 60 dB Metal: Better than 60 dB (measured via tape with peak recording level) Dolby NR switch ON: Improves up to 10 dB above 5 kHz
Harmonic Distortion	Normal: Less than 0.8% CrO ₂ : Less than 0.7% Metal: Less than 0.7%
Input	MIC: 0.25 mV (input impedance 5.0 kohms) Required microphone impedance: 600 ohms Line: 70 mV (input impedance 47 kohms)
Output	Line: 410 mV at 0 VU Required load impedance: more than 20 kohms Phone: 50mV/8 ohms at 0 VU
DIN	Input: 2 mV (Input impedance 10 kohms) Output: 410 mV Required load impedance: more than 20 kohms
Power Requirements	100V, 50/60 Hz for Japan 120V, 60 Hz for USA and Canada 220V, 50 Hz for Europe except UK 240V, 50 Hz for UK and Australia 110V/120V/220V/240V, 50/60 Hz internally switchable for other countries
Power Consumption	U/T, JPN, AAL, CAS 20W
Dimensions	440 (W) \times 118 (H) \times 270 (D) mm (17.3 \times 4.6 \times 10.6")
Weight	7.5 kg (16.5 lbs)

* For improvement purposes, specifications and design are subject to change without notice.

* "Dolby" and the Double D symbol are trademarks of Dolby Laboratories. (Manufactured under license from Dolby Laboratories).

II. DISMANTLING OF UNIT

In case of trouble, etc. necessitating dismantling, please dismantle in the order shown in the photographs. Reassemble in reverse order.

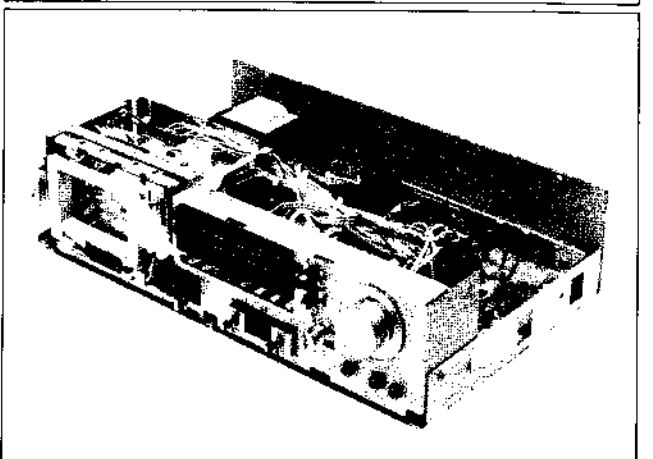
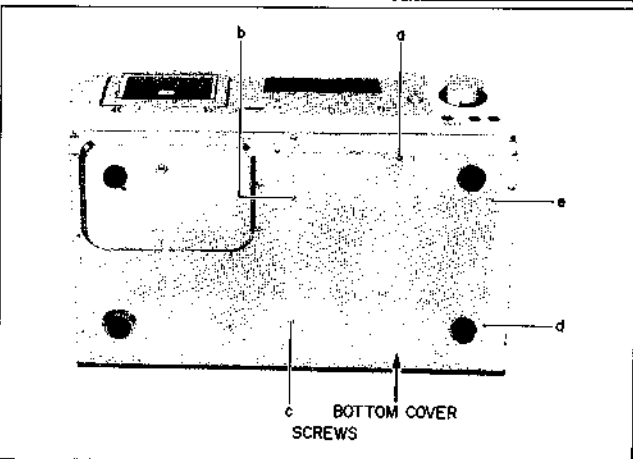
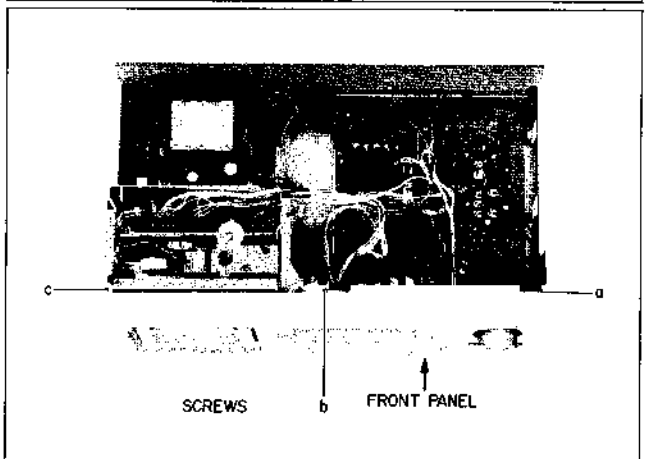
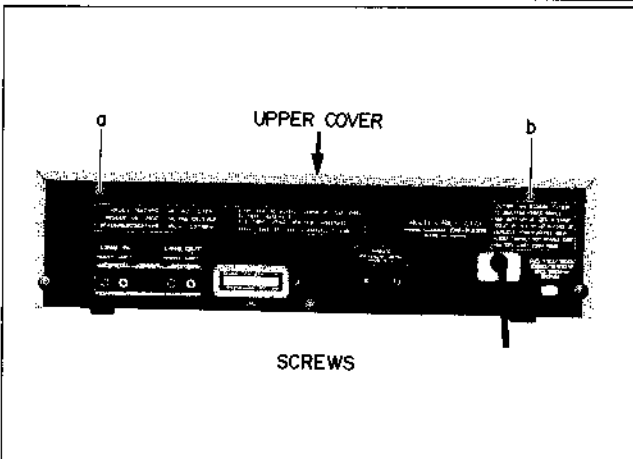
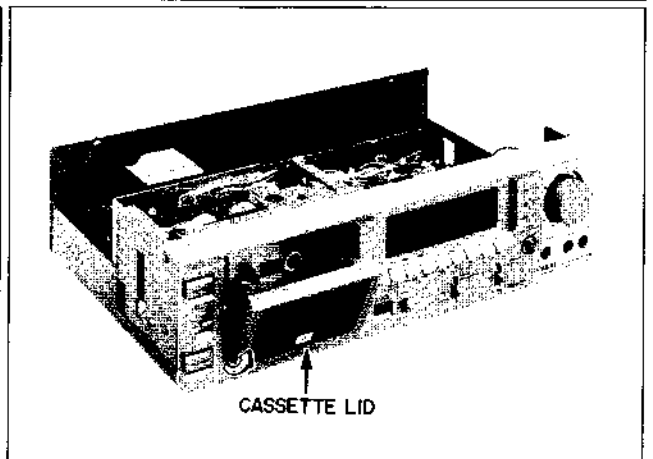
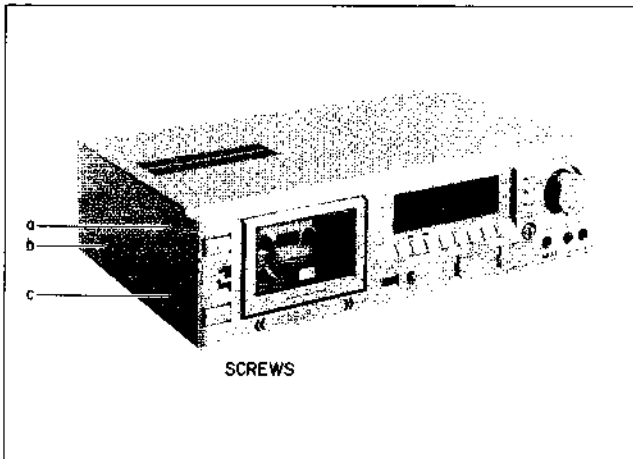
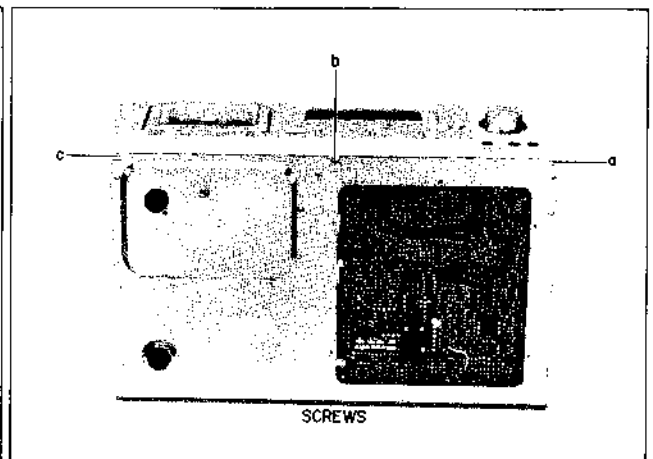
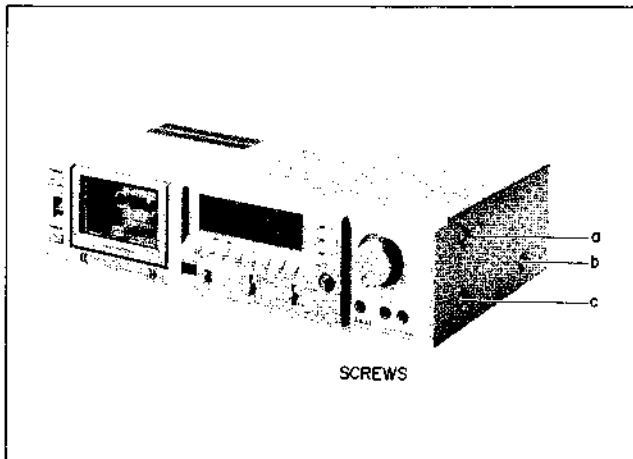

III. CONTROLS

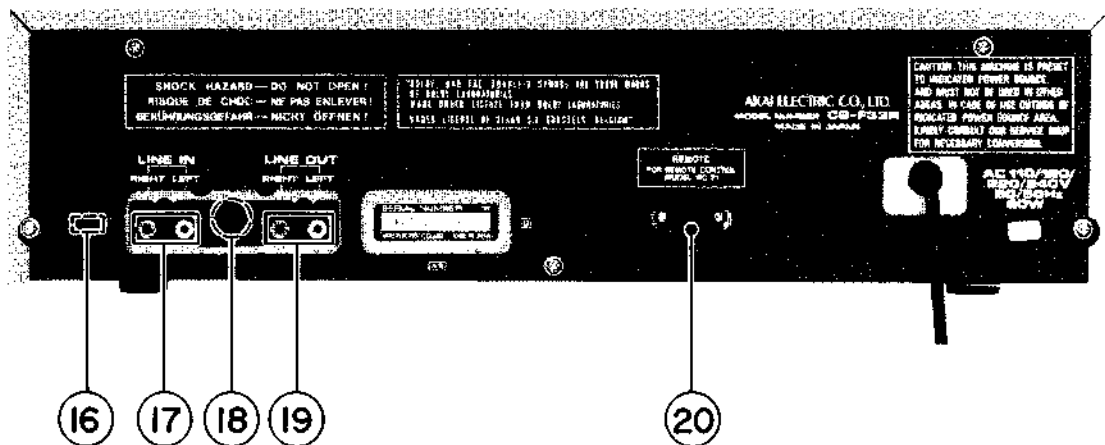
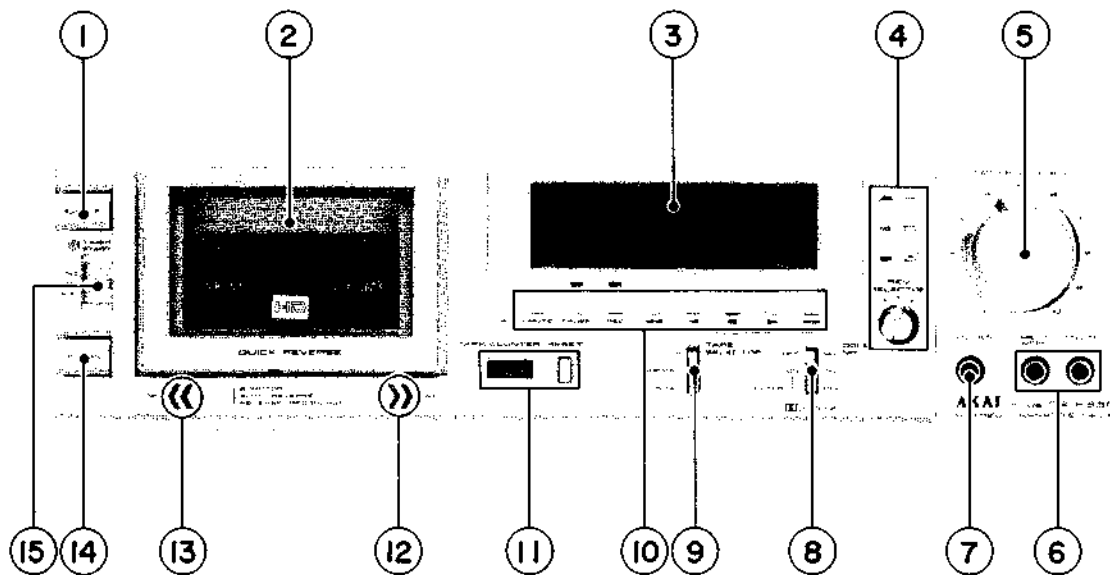

Fig. 1 Controls

- | | |
|--|--|
| <ol style="list-style-type: none"> 1. EJECT BUTTON 2. CASSETTE RECEPTACLE 3. LED BAR METERS (left and right) 4. Reverse (REV) SELECTOR and Indicators 5. LEFT → RIGHT Recording Level Controls 6. MICROPHONE JACKS MIC-L: (left), (MONO) MIC-R: (right) 7. HEADPHONES JACK (PHONES) 8. DOLBY NR AND FILTER SWITCH 9. TAPE SELECTOR 10. OPERATING BUTTONS | <ol style="list-style-type: none"> 11. TAPE COUNTER AND RESET BUTTON 12. Forward (FWD) Direction Indicator 13. Reverse (REV) Direction Indicator 14. POWER SWITCH 15. TIMER START SELECTOR 16. LINE/DIN SELECTOR (Some models do not have this facility) 17. LINE IN JACKS (right and left) 18. DIN JACK (Some models do not have this facility) 19. LINE OUT JACKS (right and left) 20. REMOTE CONTROL JACK |
|--|--|

IV. PRINCIPAL PARTS LOCATION

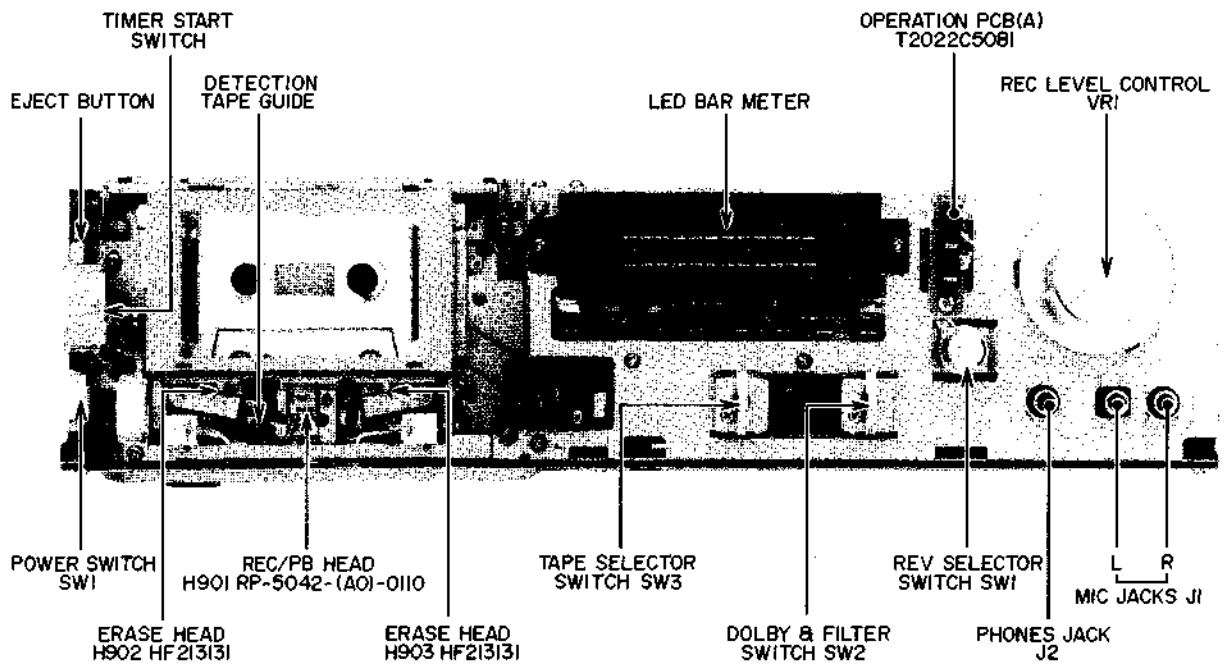

Fig. 2 Front View

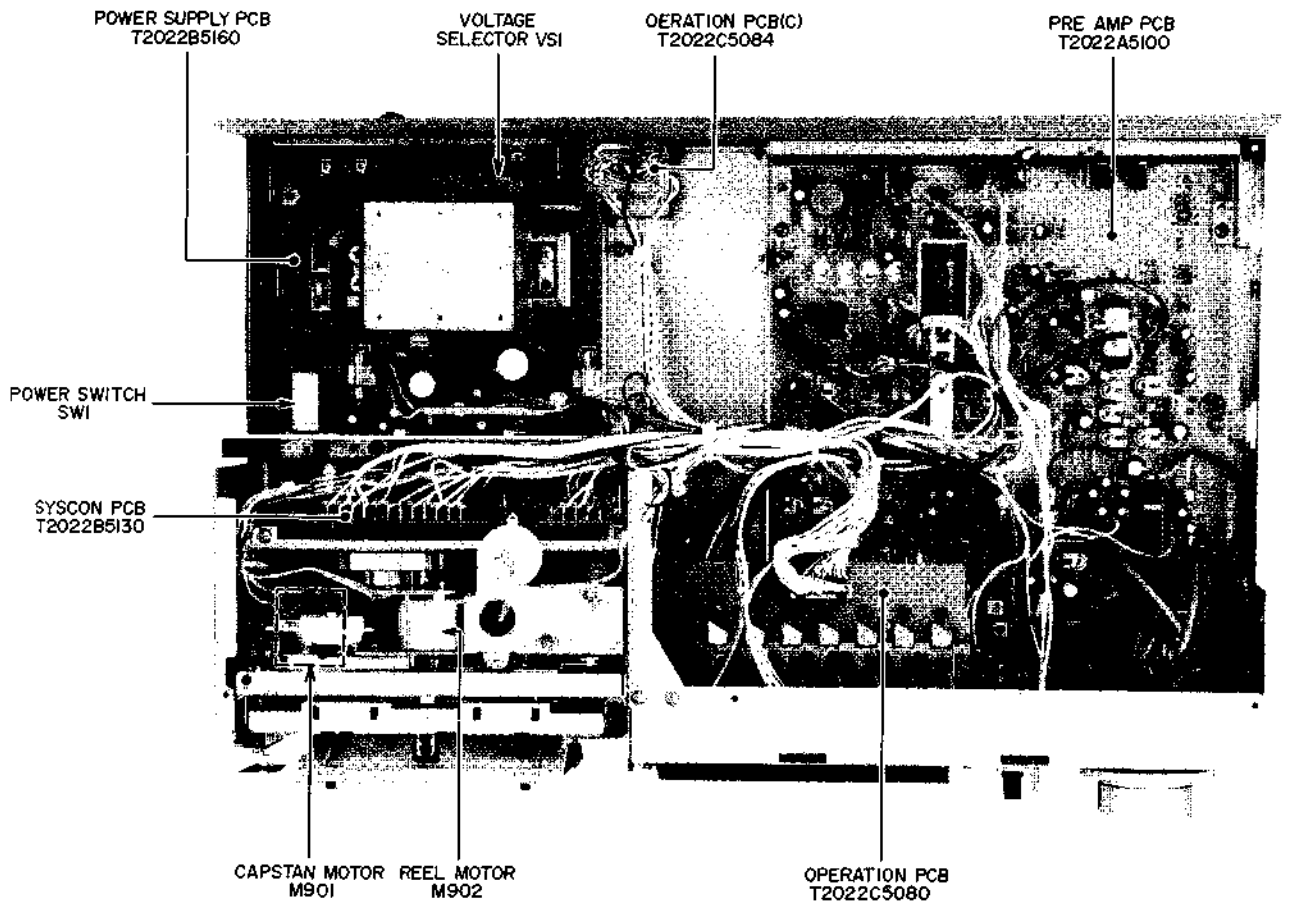

Fig. 3 Top View

V. VOLTAGE AND CYCLE CONVERSION

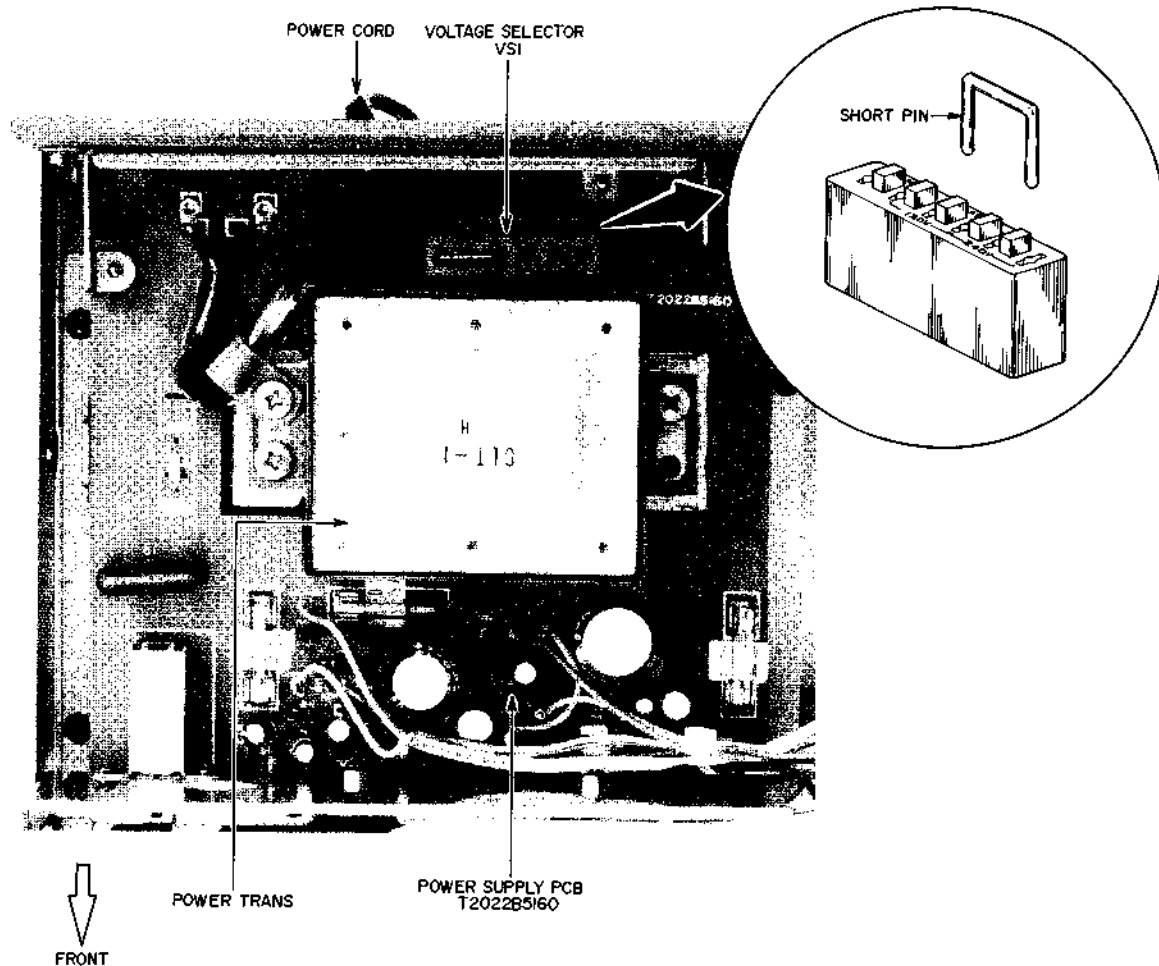

Fig. 4 Voltage Conversion (U/T Model only)

1. VOLTAGE CONVERSION

Models for Canada, Europe, USA, UK, Australia and Japan are not equipped with this facility.

Each machine is preset at the factory according to destination, but some machines can be set to 110V, 120V, 220V or 240V as required.

If voltage change is necessary, this can be accomplished as follows:

- 1) Disconnect power cord.
- 2) Loosen holding screws and remove upper cover.
- 3) Remove short pin plug from present holes and replace in correct holes.

Follow the markings explicitly.

2. CYCLE CONVERSION

With DC motor, cycle conversion is not necessary.

VI. MECHANICAL ADJUSTMENT

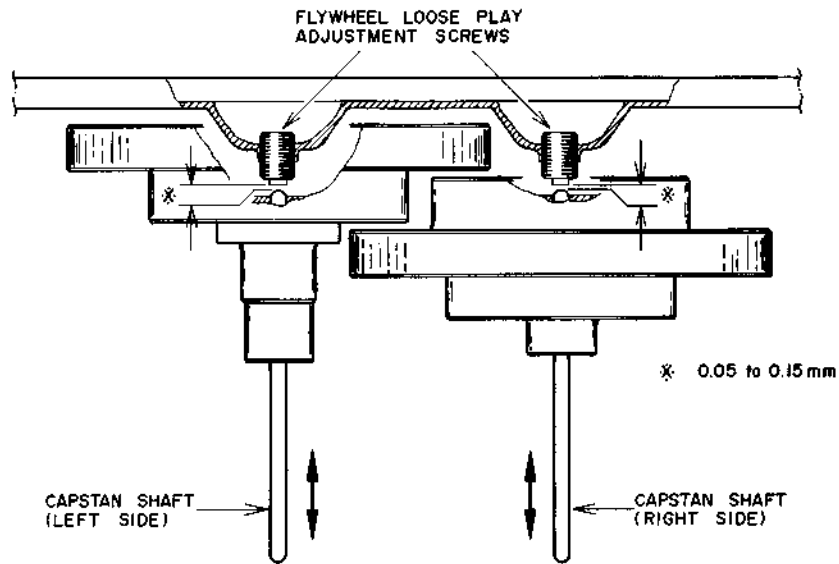

Fig. 5

1. FLYWHEEL LOOSE PLAY ADJUSTMENT

(Refer to Fig. 5)

Adjust by turning flywheel loose play adjustment screws to obtain 0.05 to 0.15 mm of loose play when the capstan shaft is moved as indicated by the arrow mark.

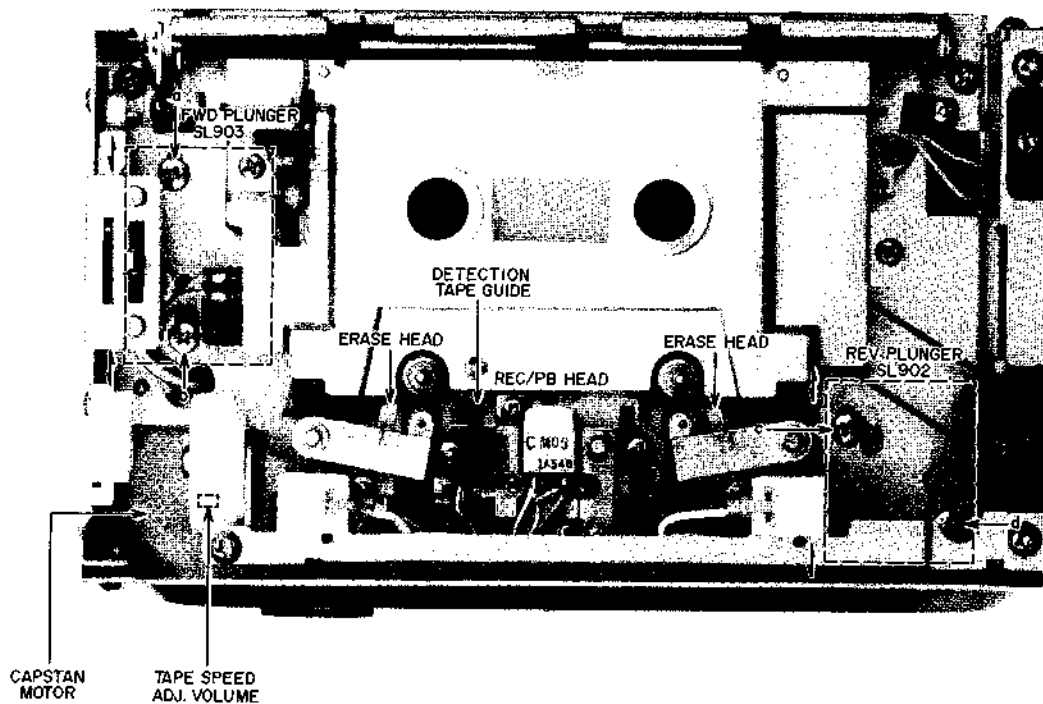

Fig. 6

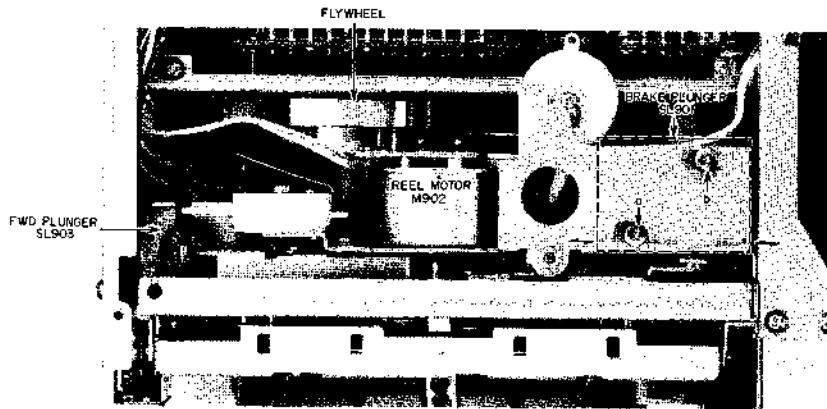

Fig. 7

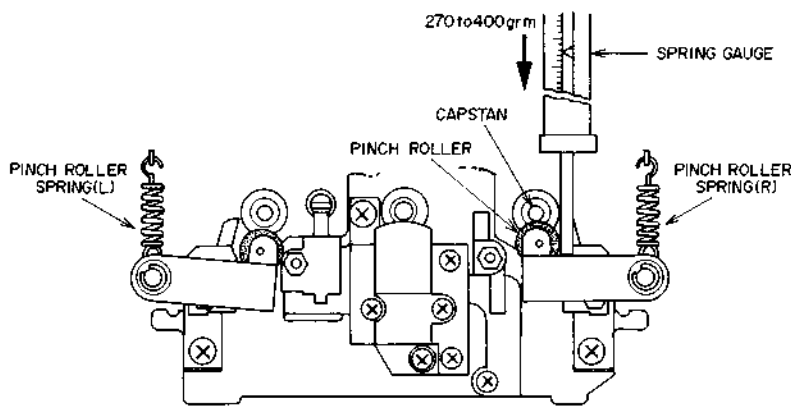

Fig. 9

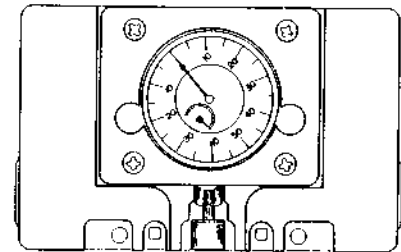

Fig. 8 AKAI Head Projection Gauge

2. PLUNGER POSITION ADJUSTMENT

- 1) Forward Plunger Adjustment (Refer to Figs. 6, 8)
Set the AKAI Head Projection Gauge.
Adjust the screws (a) and (b) so that when FWD PAUSE mode is engaged, the Head Projection Gauge indicates to $2.7 \text{ mm} \pm 0.1 \text{ mm}$.
- 2) Brake Plunger Adjustment (Refer to Figs, 7, 8)
Set the AKAI Head Projection Gauge.
Adjust the screws (a) and (b) so that when FWD PLAY mode is engaged, the Head Projection Gauge indicates to $3.35 \text{ mm} \pm 0.1 \text{ mm}$.
- 3) Reverse Plunger Adjustment (Refer to Figs. 6, 8)
Set the AKAI Head Projection Gauge.
Adjust the screws (c) and (d) so that when REV PAUSE mode is engaged, the Head Projection Gauge indicates to $2.5 \text{ mm} \pm 0.1 \text{ mm}$.

NOTE: This adjustment made is order of numbers.

3. PINCH ROLLER PRESSURE

MEASUREMENT (Refer to Fig. 9)

Put in FWD PLAY mode. Push pinch roller arm down with the spring gauge push the pinch roller 1 ~ 2 mm from the capstan and release slowly.

Read the spring gauge at the moment the pinch roller touches the capstan and begins to rotate.

Specified contact pressure measurement of 270 to 400 gm.

If there is no measurement obtained, replace the pinch roller spring. Do the same for the reverse side.

4. WINDING TORQUE MEASUREMENT

IN EACH MODE

Insert cassette torque meter and measure in each mode.

For fast forward and rewind measure at the end of the tape when the tape has stopped running.

Forward, Reverse : 30 to 55 g-cm

Fast Forward, Rewind: 75 to 130 g-cm

5. TAPE SPEED ADJUSTMENT

(Refer to Fig. 6)

Connect a frequency counter to line output terminals. Playback a 1,000 Hz pre-recorded test tape and adjust tape speed adjustment volume to obtain a tape speed of $995 \text{ Hz} \pm 5 \text{ Hz}$.

VII. HEAD ADJUSTMENT

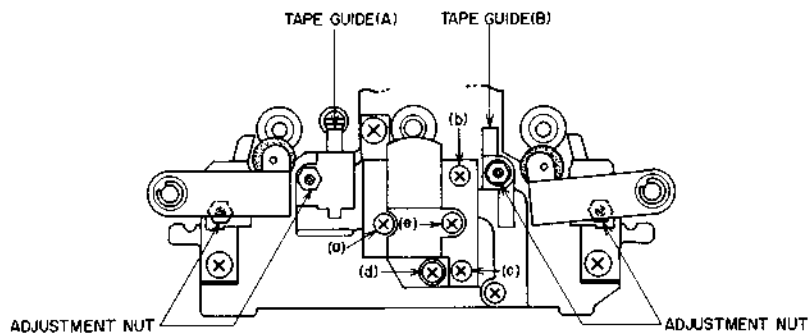

Fig. 10

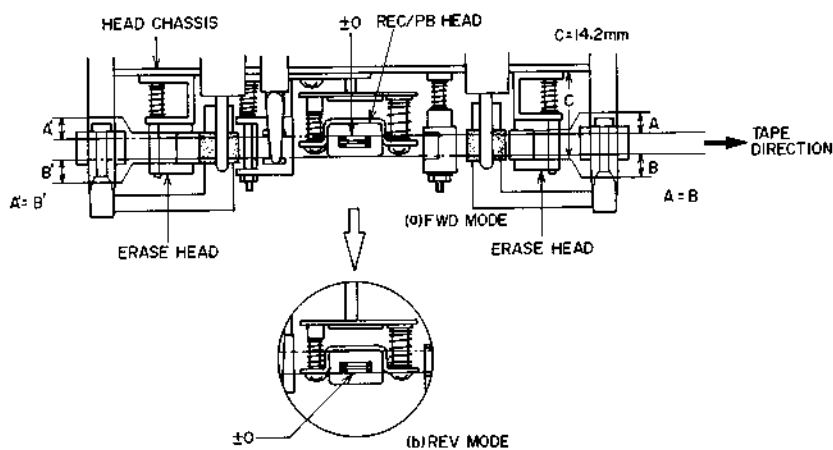

Fig. 11

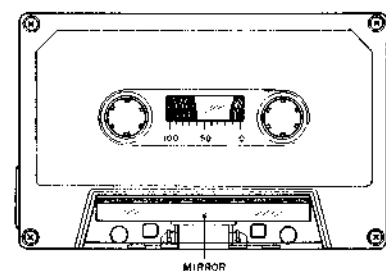

Fig. 12

1. ERASE HEAD HEIGHT ADJUSTMENT

(Refer to Figs. 10 to 12)

Usually this adjustment is not carried out. If adjustment is necessitated by head change for example, proceed as follows:

Adjust by turning the adjustment nut until the height, taken from the surface of the Head Chassis to the lower tip of the Erase Head Core (Fig. 11 C) is 14.2 mm

2. TAPE GUIDE HEIGHT ADJUSTMENT

(Refer to Figs. 10 to 12)

- 1) When using an ordinary cassette, the tape guides and heads, etc. are not visible. As shown in Fig. 12 use a cassette tape from which part of the cassette case has been cut out and a mirror installed easy visibility of the head area when making tape guide height adjustment.
- 2) The adjustment to Tape Guides (A) and (B) are carried out with the Erase Head at the standard height. Put into the FWD mode and adjust Tape Guide (A). Make the width of the sections (A and B in Fig. 11) protruding from both ends of the tape of the left side Erase Head the same. Next in the REV mode adjust Tape Guide (B) until A and B in Fig. 11 are the same. Finally, in either FWD or REV modes. Check that the tape is running smoothly without catching on the tape guides.

3. REC/PB HEAD HEIGHT

ADJUSTMENT (Refer to Figs. 10 to 12)

Playback the Head Height Adjustment Tape (4 Track 1,000 Hz) in the Reverse Play Mode and adjust the screws (a) (b) and (c) until the output level of both channels reaches maximum.

Next put in the Forward Mode and adjust the screws (d) and (e) so that output level reaches maximum same as above.

4. REC/PB HEAD AZIMUTH

ADJUSTMENT (Refer to Fig 10)

- 1) Playback the azimuth adjustment tape (10 kHz) in the REV PLAY mode and adjust screws (a), (b), (c) until the output level of both channels reaches maximum (the AC voltmeter registers maximum).
- 2) Put in reverse mode and check that the output level is the same as in the forward mode. If different, adjust with screws (a), (b), (c) until the level is the same in both modes.
- 3) After adjustment, check both the head height and the azimuth.

Notes:

1. Be sure to clean the heads prior to head adjustment.
2. Be careful not to use a magnetized driver or other magnetized tools in the vicinity of the heads.
3. Be sure to demagnetize the heads with a Head Demagnetizer before and after head adjustment.

VIII. ELECTRICAL ADJUSTMENT

1. QUICK REVERSE SENSITIVITY ADJUSTMENT



Fig. 13 Syscon P.C Board
 T2022B5120 (C,A)
 T2022B5130 (U,J,E,B,S)

- 1) Make a tapeless cassette pack by removing the tape from the white colored test tape.
 - 2) Connect the AC Voltmeter between the PIN (A) and earth.
 - 3) Using the tapeless cassette pack, adjust VR-1 so that the AC Voltmeter indicates $10V \pm 0.5V$ at REV play mode.
- NOTE:** Use only a clean tapeless cassette pack.

2. AMPLIFIER ADJUSTMENT

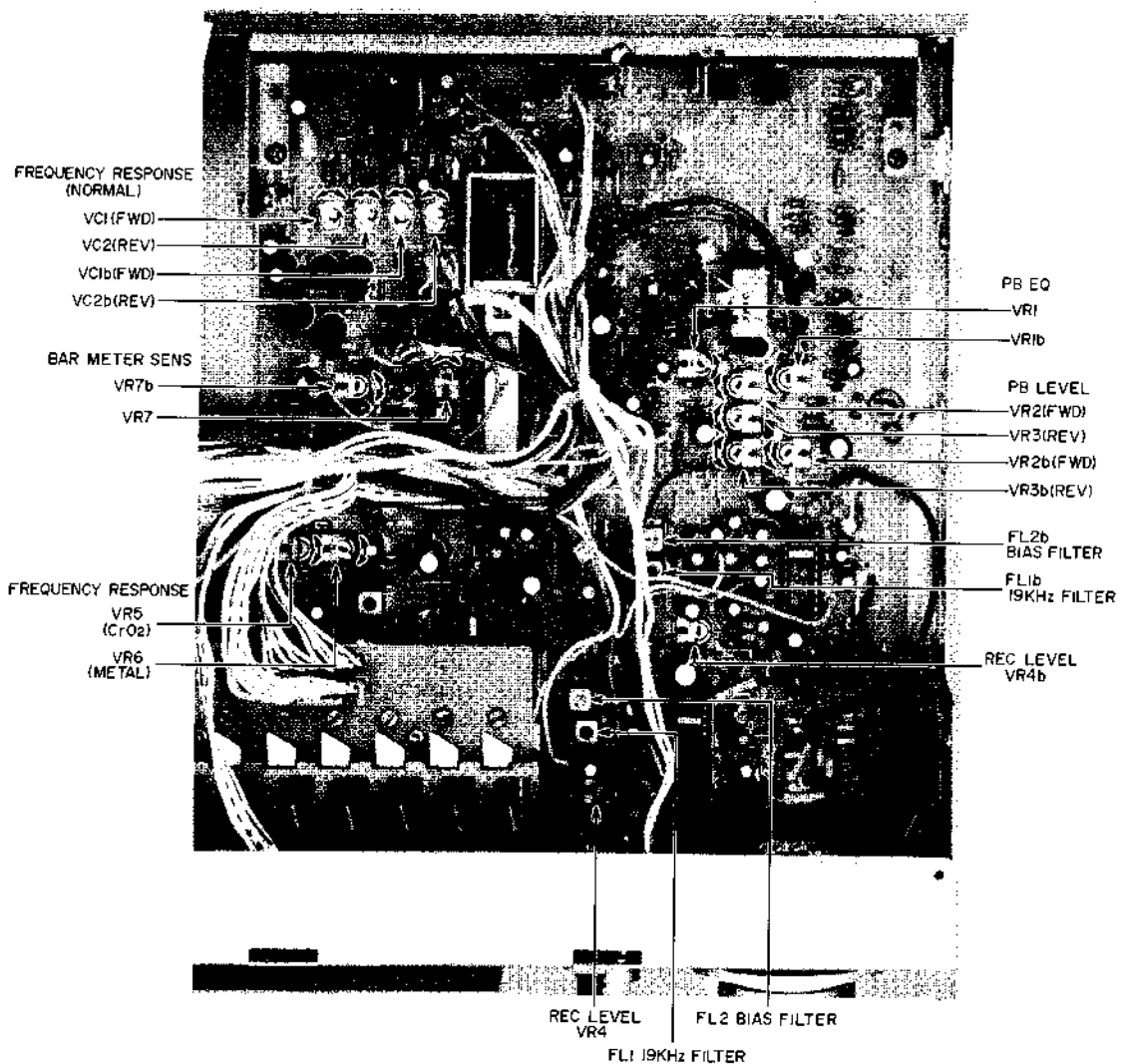

Fig. 14

STEP	ADJUSTMENT ITEM	TEST TAPE SUPPLY SIGNAL	MODE	ADJUSTMENT POINT	RESULT	REMARKS
1	FWD Playback Level	333 Hz 0 VU Test Tape	FWD PB	VR2	-5.5±0.5 dBm (410 mV)	
2	REV Playback Level	333 Hz 0 VU Test Tape	REV PB	VR3	-5.5±0.5 dBm (410 mV)	
3	Bar Meter Sensitivity	1,000 Hz -5.5 dBm from oscillator	FWD-REC	VR7	0 VU indication	
4	PB EQ	10,000 Hz Test Tape	FWD-REV/PB	VR1	-19±1.5 dBm	
5	Normal Position Frequency Response (FWD)	Normal Blank Tape, 1,000 Hz, 10,000 Hz -24.5 dBm recording	FWD-REC/PB	VC1	1,000 Hz to 10,000 Hz flat response	
6	Normal Position Frequency Response (REV)	Normal Blank Tape 1,000 Hz, 10,000 Hz -25.5 dBm recording	REV-REC/PB	VC2	1,000 Hz to 10,000 Hz flat response	
7	CrO ₂ Position Frequency Response	CrO ₂ Blank Tape, 1,000 Hz, 10,000 Hz -25.5 dBm recording	FWD/REV-REC/PB	VR5	1,000 Hz to 10,000 Hz flat response	Set tape selector to CrO ₂ Position
8	Metal Position Frequency Response	CrO ₂ Tape, 1,000 Hz, 10,000 Hz -25.5 dBm recording	FWD/REV-REC/PB	VR6	1,000 Hz to 10,000 Hz flat response	Set tape selector to Metal Position
9	Recording Level	Normal Blank Tape 1,000 Hz -5.5 dBm recording	FWD/REV-REC/PB	VR4	-5.5±0.5 dBm (410 mV)	
10	FWD Distortion Factor confirmation	1,000 Hz -5.5 dBm recording	FWD-REC/PB		Normal <0.8% CrO ₂ <0.7% Metal <0.7%	NOTE 7
11	REV Distortion Factor Confirmation	1,000 Hz -5.5 dBm recording	REV-REC/PB		Normal <0.8% CrO ₂ <0.7% Metal <0.7%	NOTE 7
12	Bias Filter	No signal input	REC	FL2	AC Voltmeter indicates to minimum	Set tape Selector to Metal position. Set REC Volume to maximum NOTE 8
13	19 kHz Filter	19 kHz from Oscillator	REC	FL1	AC Voltmeter indicates to minimum	Set Dolby NR switch to ON. Filter ON position NOTE 8, 9

NOTES:

- Input selector switch to LINE.
(The U/T, CSA, AAL and JPN Models do not have this facility.)
- Because each of these adjustments is vital to perfect Dolby NR circuit operation, ensure that they are carried out with as few errors as possible.
- Except for Step 7, 8, 10, 11 and 12, set Tape Selector to NORMAL Position.
- Except for Step 13 set Dolby NR switch to OFF Position.
- Use the following cassette measuring tapes:
Normal Tape: Maxell UD C-60
CrO₂ Tape: TDK SA C-60
Metal Tape: TDK MA-C C-60
- Use the test tape of 10 kHz recorded at the level of -18.7 dBm.
- If it does not comply with the specifications, repeat Steps 5 to 9 and readjust.
- Unless the core is moved unintentionally this adjustment is not necessary.
- Adjust the oscillator's frequency to give a frequency counter reading of 19.00 kHz.

IX. DC RESISTANCE OF VARIOUS COILS

DESCRIPTION	NAME	DC RESISTANCE
REC/PB Head	RP-5402-(AO)-0110	300 ohms \pm 20%
Erase Head	HF213131	3.2 ohms
Plunger Solenoid	1240PLT	90 ohms \pm 10%

X. CLASSIFICATION OF VARIOUS P.C BOARDS

1. P.C BOARD TITLES AND IDENTIFICATION NUMBERS

P.C BOARD TITLE	P.C BOARD NUMBER	REMARKS
Pre Amp P.C Board	T2022A5100	
Volume P.C Board	T2022A5101	
Syscon P.C Board	T2022B5120	CSA, AAL
Syscon P.C Board	T2022B5130	U/T, JPN, CEE, UK, SA/
Power Supply P.C Board	T2022B5160	U/T
Power Supply P.C Board	T2022B5170	JPN
Power Supply P.C Board	T2022B5180	CSA, AAL
Power Supply P.C Board	T2022B5190	CEE, UK, SAA
Operation P.C Board	T2022C5080	
Operation P.C Board (A)	T2022C5081	
Operation P.C Board (B)	T2022C5083	
Operation P.C Board (C)	T2022C5084	
Lamp P.C Board	T2022D5140	
Detector P.C Board	T2022D5150	
LED P.C BOARD	T2022D5200	
Filter P.C Board	CL-5026	

2. COMPOSITION OF VARIOUS P.C BOARDS

1) Pre Amp P.C Board T2022A5100 (2ED), Volume P.C Board T2022A5101 and Operation P.C Board (A/B) T2022C5081/T2022C5083.

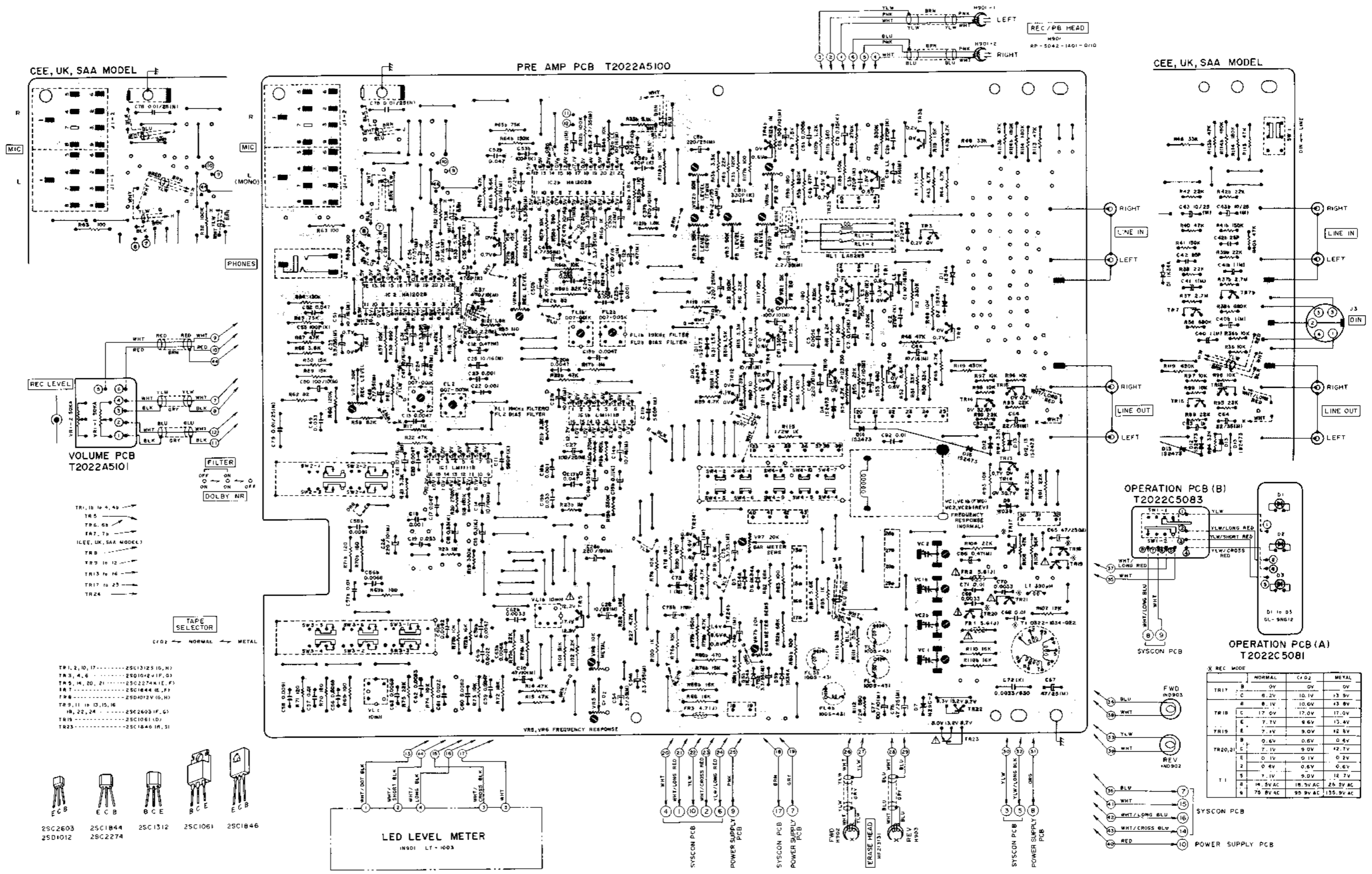

REC MODE	NORMAL		METAL	
	TRIT	TRIS	TRD	TRC
TRIS	B	0V	0V	0V
	C	8.2V	10.0V	13.5V
	E	17.0V	17.0V	17.0V
TRIS	B	7.1V	9.6V	13.4V
	C	7.1V	9.0V	12.8V
	E	0.6V	0.6V	0.6V
TRD, TRC	B	7.1V	9.0V	12.7V
	C	0.1V	0.1V	0.2V
	E	0.6V	0.6V	0.6V
T1	B	7.1V	9.0V	12.7V
	C	14.5V AC	18.5V AC	25.5V AC
	E	75.8V AC	95.8V AC	135.8V AC

WARNING: Δ INDICATES SAFETY CRITICAL COMPONENTS. FOR CONTINUED SAFETY, REPLACE SAFETY CRITICAL COMPONENTS ONLY WITH MANUFACTURER'S RECOMMENDED PARTS.
 AVERTISSEMENT: Δ IL INDIQUE LES COMPOSANTS CRITIQUES DE SÛRETÉ. POUR MAINTENIR LE DEGRÉ DE SÛRETÉ DE L'APPAREIL, NE REMPLACER LES COMPOSANTS DONT LE FONCTIONNEMENT EST CRITIQUE POUR LA SÛRETÉ QUE PAR DES PIÈCES RECOMMANDÉES PAR LE FABRICANT.

2) Syscon P.C Board (U,J,E,B,S) T2022B5130 (2ED)/(C,A) T2022B5120 (2ED), Filter P.C Board CL-5026 (2ED), Detector P.C Board T2022D5150 and LED P.C Board T2022D5200.

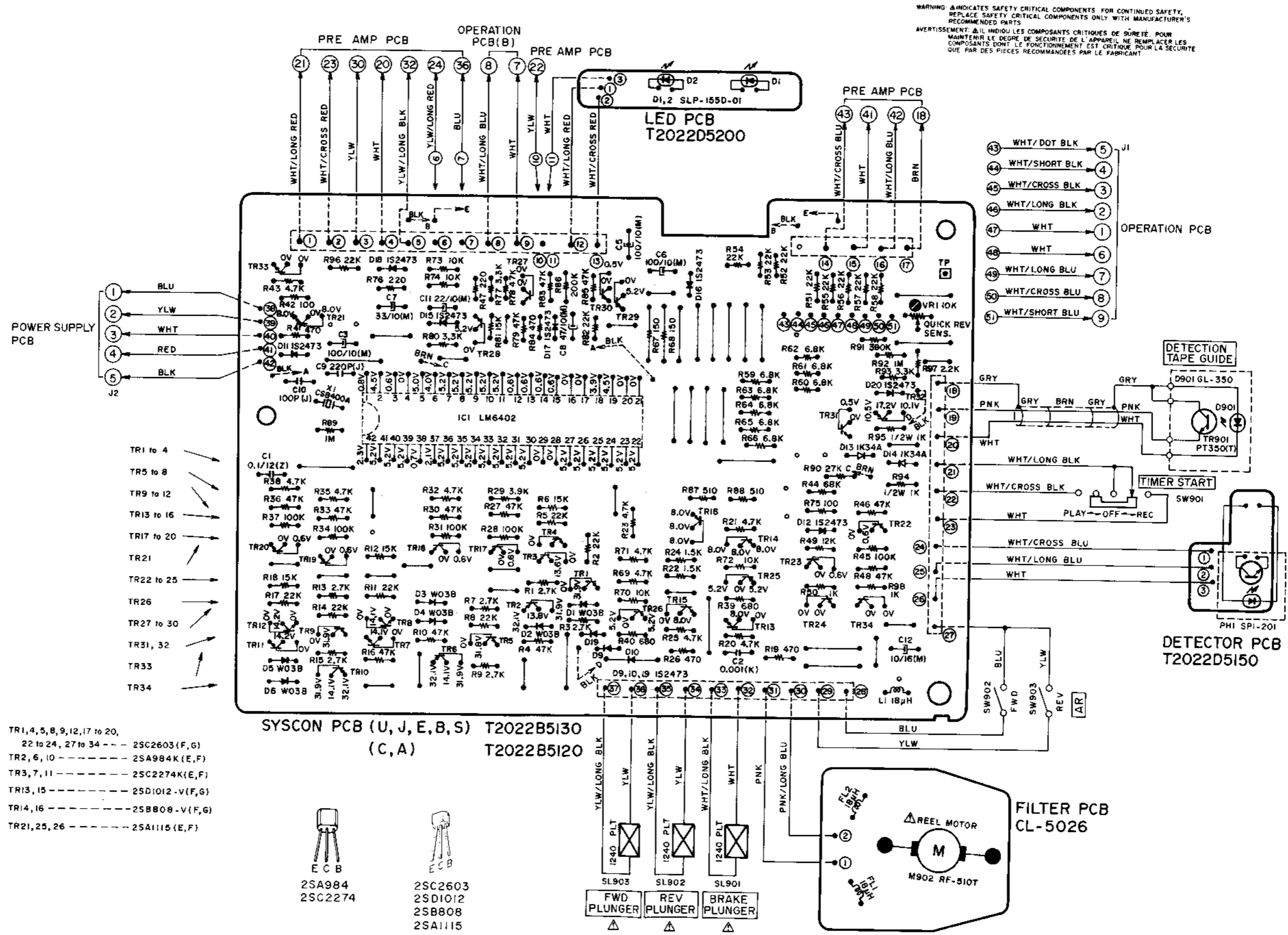

3) Power Supply P.C Board (U) T2022B5160 (2ED) and Lamp P.C Board T2022D5140

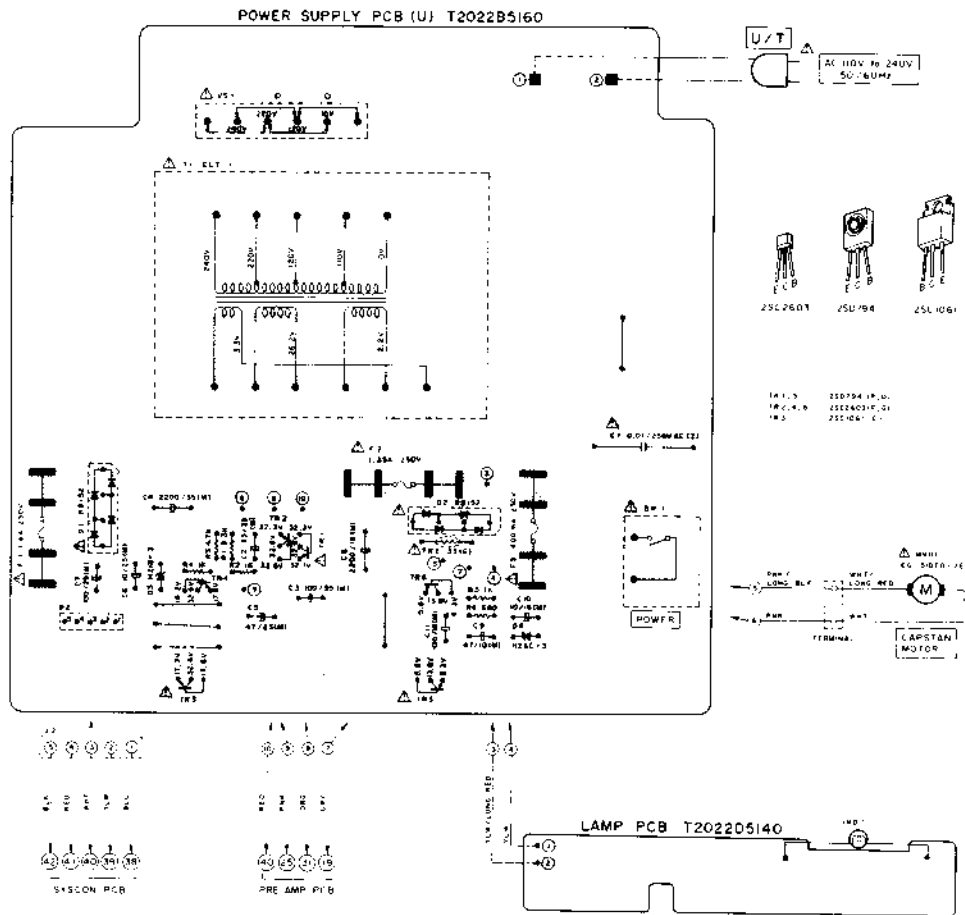

4) Power Supply P.C Board (J) T2022B5170 (2ED)

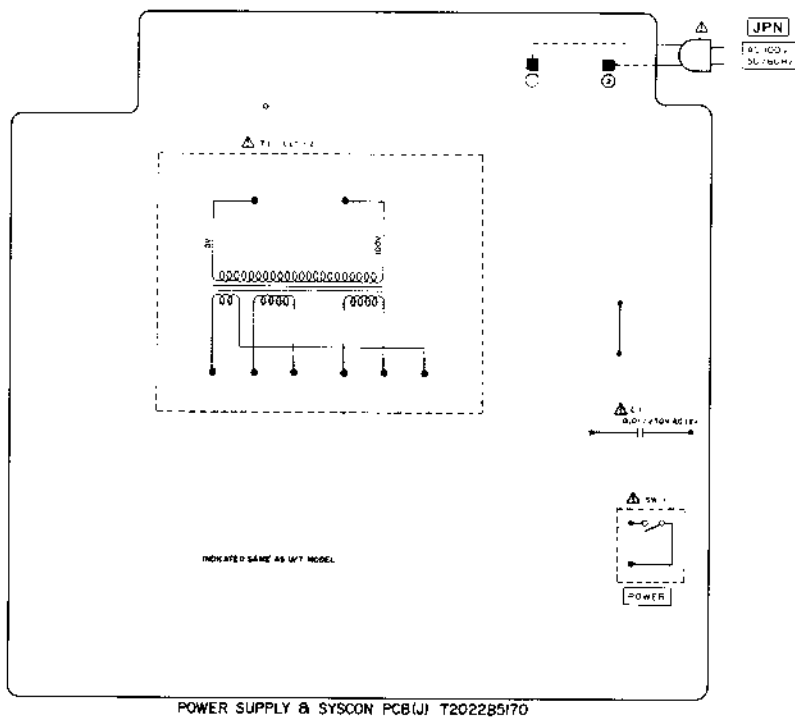

WARNING: Δ INDICATES SAFETY CRITICAL COMPONENTS. FOR CONTINUED SAFETY, REPLACE SAFETY CRITICAL COMPONENTS ONLY WITH MANUFACTURER'S RECOMMENDED PARTS.
 AVERTISSEMENT: Δ IL INDIQUE LES COMPOSANTS CRITIQUES DE SÛRETÉ. POUR MAINTENIR LE DEGRÉ DE SÛRETÉ DE L'APPAREIL, NE REMPLACER LES COMPOSANTS DONT LE FONCTIONNEMENT EST CRITIQUE POUR LA SÛRETÉ QUE PAR DES PIÈCES RECOMMANDÉES PAR LE FABRICANT.

5) Power Supply P.C Board (C, A) T2022B5180 (2ED)

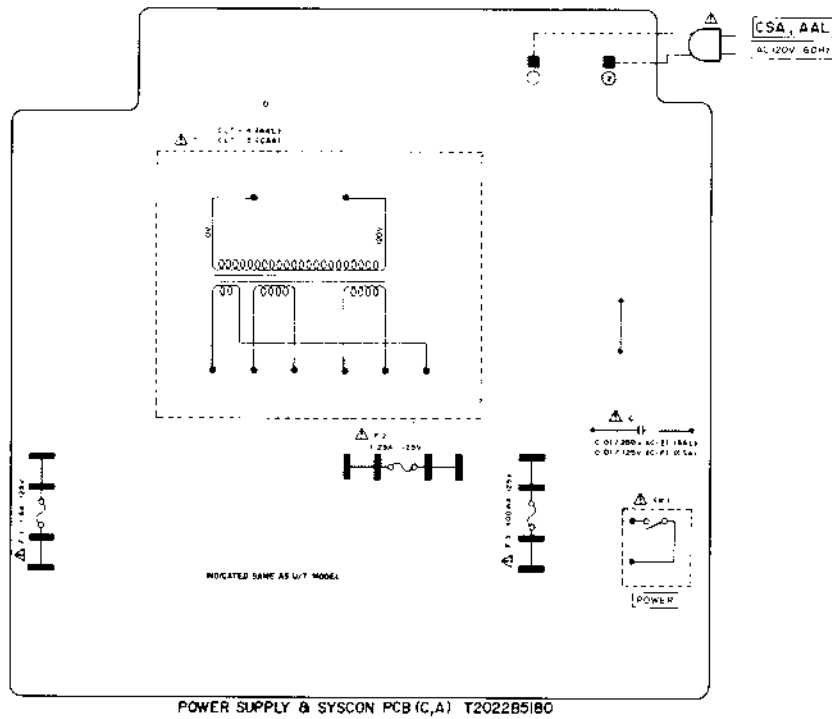

6) Power Supply P.C Board (E, B, S) T2022B5190 (2ED)

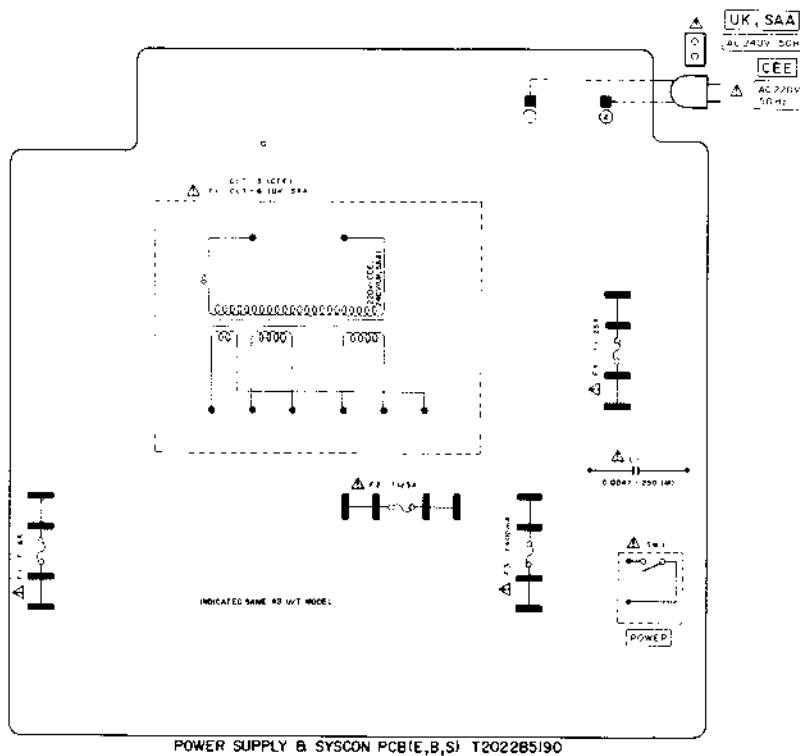

WARNING ΔINDICATES SAFETY CRITICAL COMPONENTS FOR CONTINUED SAFETY. REPLACE SAFETY CRITICAL COMPONENTS ONLY WITH MANUFACTURER'S RECOMMENDED PARTS.
 AVERTISSEMENT: ΔIL INDIQUE LES COMPOSANTS CRITIQUES DE SÛRETÉ POUR MAINTENIR LE DEGRÉ DE SÛRETÉ DE L'APPAREIL. NE REMPLACER LES COMPOSANTS DONT LE FONCTIONNEMENT EST CRITIQUE POUR LA SÛRETÉ QUE PAR DES PIÈCES RECOMMANDÉES PAR LE FABRICANT.

7) Operation P.C Board T2022C5080 and Operation P.C Board (C) T2022C5084

OPERATION PCB T2022C5080

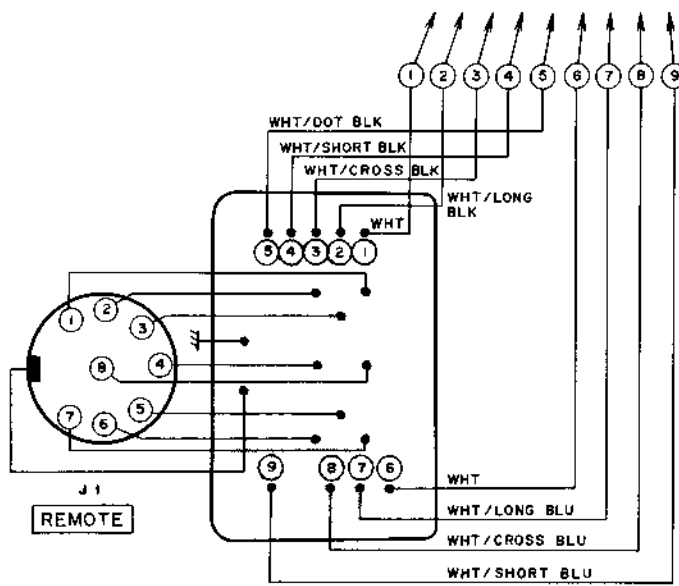
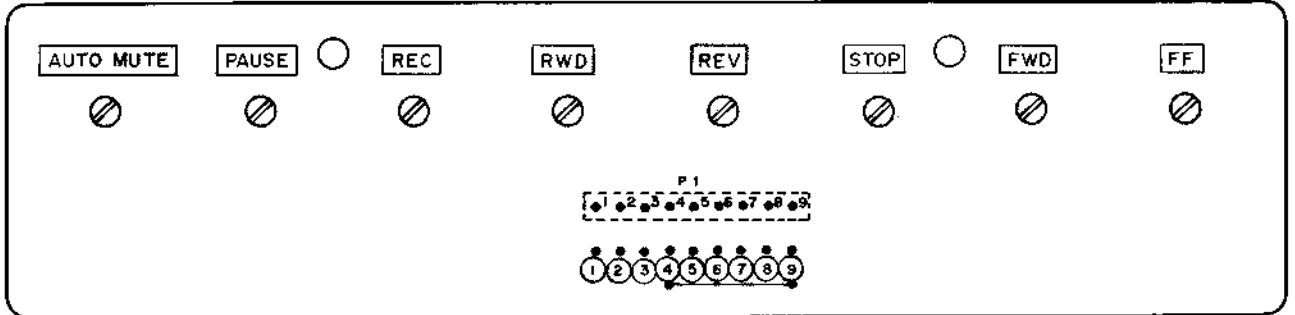

OPERATION PCB (C)
T2022C5084

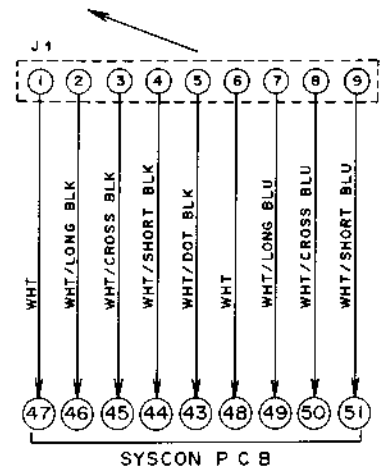

MEMO

MEMO

MEMO

SECTION 2

PARTS LIST

TABLE OF CONTENTS

1. RECOMMENDED SPARE PARTS LIST.....	26
2. HEAD BASE BLOCK	28
3. REEL BASE BLOCK	29
4. MECHA FRAME BLOCK.....	30
5. GROUP (1) P.C BOARD (T2022A5100, T2022A5101) BLOCK	32
6. SYS. CON. P.C BOARD (T2022B5120/T2022B5130) BLOCK	32
7. POWER SUPPLY P.C BOARD (T2022B5160/ T2022B5170/T2022B5180/T2022B5190) BLOCK.....	33
8. LED P.C BOARD (T2022D5200) BLOCK	33
9. OPERATION (C) P.C BOARD (T2022C5084) BLOCK.....	33
10. OPERATION (A) P.C BOARD (T2022C5081) BLOCK.....	33
11. OPERATION (B) P.C BOARD (T2022C5083) BLOCK.....	33
12. ASSEMBLY BLOCK	34
13. FINAL ASSEMBLY BLOCK	36
INDEX	37

Resistor and Capacitor which are not listed in this parts list, please refer to
COMMON LIST FOR SERVICE PARTS.

HOW TO USE THIS PARTS LIST

1. This parts list is compiled by various individual blocks based on assembly process.
2. When ordering parts, please describe parts number, serial number, and model number in detail.
3. How to read list.

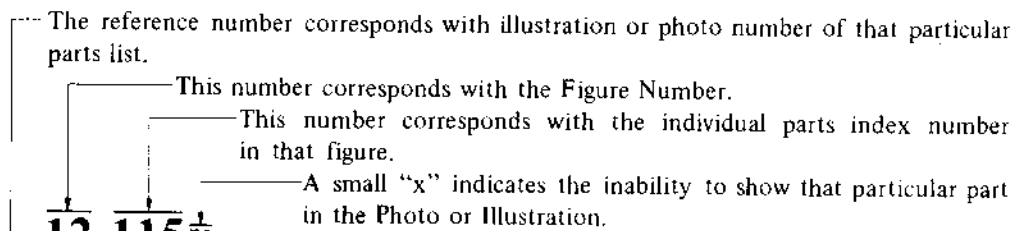

12-115x

Ref. No. Parts No. Description

FLYWHEEL BLOCK #13

12-115x	800425	Flywheel Block Assy. Comp.
12-116	244506	Flywheel Only
12-117x	244754	Felt, Flywheel
12-118	251324	Main Metal Case
12-119	253080	Main Metal

4. The symbol numbers shown on the P.C. Board list can be matched with the Composite Views of components of the Schematic Diagram or Service Manual.
5. The indications of Resistors and Capacitors in the photos of P.C. Board are being eliminated.
6. The shape of the parts and parts name, etc. can be confirmed by comparing them with the parts shown on the Electrical Parts Table of P.C. Board.
7. Both the kind of part and installation position can be determined by the Parts Number. To determine where a parts number is listed, utilize Parts Index at end of Parts List.
It is necessary first of all to find the Parts Number. This can be accomplished by using the Reference Number listed at right of parts number in the Parts Index. (meaning of ref. no. outlined in Item 3 above).
8. Utilize separate "Price List for Parts" to determine unit price. The most simple method of finding parts Price is to utilize the reference number.

CAUTION:

1. When placing an order for parts, be sure to list the parts no. model no., and description. There are instances in which if any of this information is omitted, parts cannot be shipped or the wrong parts will be delivered.
2. Please be careful not to make a mistake in the parts no. If the parts no. is in error, a part different from the one ordered may be delivered.
3. Because parts number and parts unit supply in the Preliminary Service Manual (Basic Parts List) may be partially changed, please use this parts list for all future reference.

WARNING: △ INDICATES SAFETY CRITICAL COMPONENTS. FOR CONTINUED SAFETY, REPLACE SAFETY CRITICAL COMPONENTS ONLY WITH MANUFACTURER'S RECOMMENDED PARTS.

AVERTISSEMENT: △ IL INDIQU LES COMPOSANTS CRITIQUES DE SURETE. POUR MAINTENIR LE DEGRE DE SECURITE DE L'APPAREIL NE REMPLACER LES COMPOSANTS DONT LE FONCTIONNEMENT EST CRITIQUE POUR LA SECURITE QUE PAR DES PIECES RECOMMANDEES PAR LE FABRICANT.

AC INLET SYSTEM

This model is equipped with an AC INLET SYSTEM. Please refer to the AC INLET SYSTEM CHART below for the specific type. By the AC INLET SYSTEM, AC (mains) cord can be connected to and disconnected from the model because the model is provided with socket exclusively for AC (mains) cord on its main body. Please note, however, that certain models are not equipped with this system and has a built-in AC (mains) cord as before.

AC INLET SYSTEM CHART

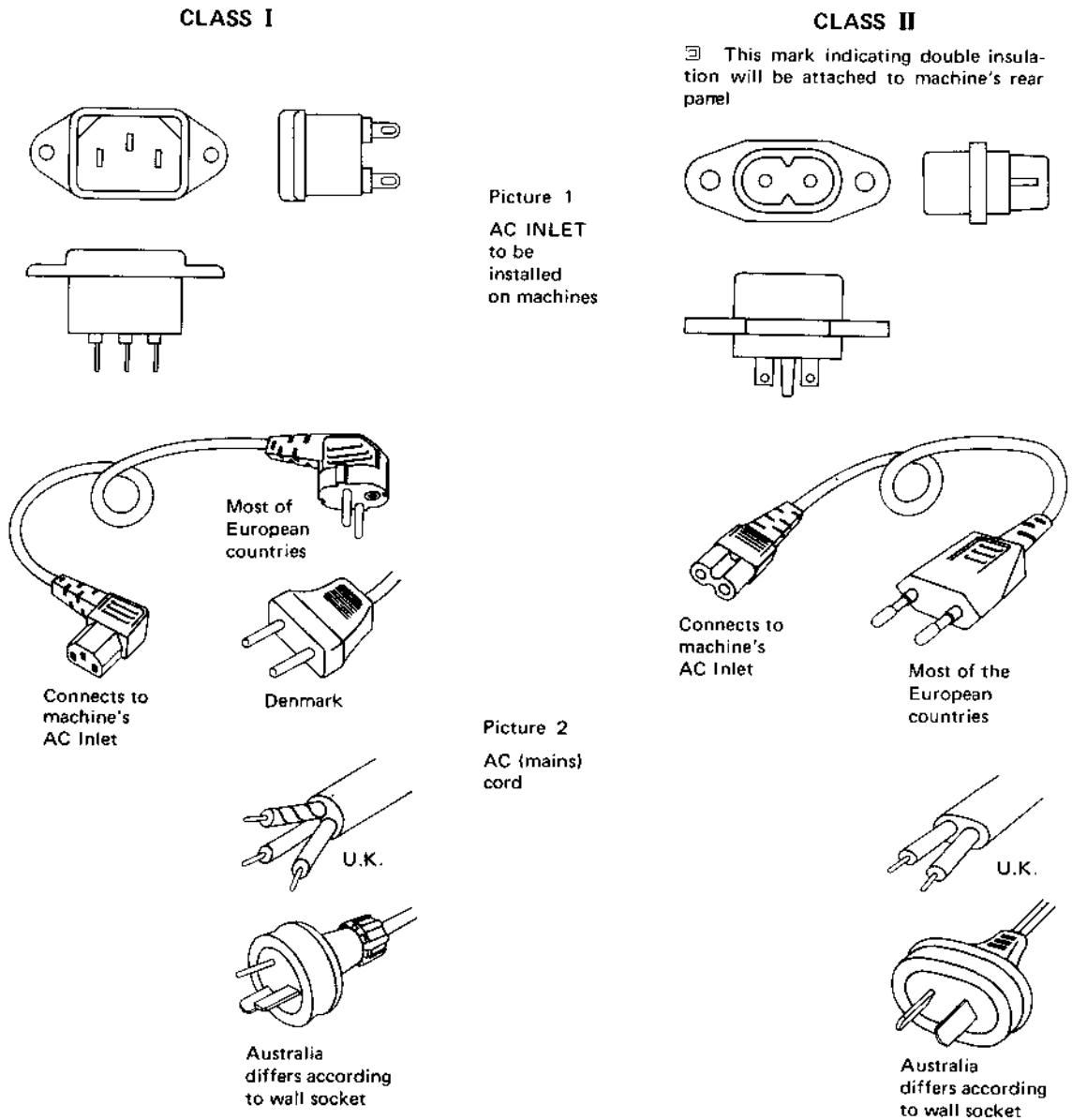

Parts List for AC (mains) Cord Set

Standard		Description	Type of AC Inlet	Parts No.
Class I	CEE	Cord Set CEE (3 cores)	3P	EW302993
	UK	Cord Set UK (3 cores)	3P	EW302994
	SAA	Cord Set SAA (3 cores)	3P	EW302996
	U/T	Cord Set U/T (3 cores)	3P	EW302646
Class II	CEE	Cord Set CEE (2 cores)	2P	EW638144
	UK	Cord Set UK (2 cores)	2P	EW302995
	SAA	Cord Set SAA (2 cores)	2P	EW302991
	U/T	Cord Set U/T (2 cores)	2P	EW302899

1. RECOMMENDED SPARE PARTS LIST

Because, if the parts listed below are on hand, almost any repair can be accomplished, we suggest that you stock these Recommended Spare Parts Items.

Ref. No.	Parts No.	Description	Note
1- 1.	BHT2022A110A	HEAD BASE BLK CS-F33R	
1- 2.	BI312117	REW IDLER ASSY	
1- 3.	BI312118	TAKE-UP IDLER ASSY	
1- 4.	BMT2022A080A	△ MOTOR (PULLEY) BLK CS-F33R	
1- 5.	BMT2016A320A	△ REEL MOTOR BLK (W/PULLEY) GX-F35	
1- 6.	BR328424	TAKE-UP REEL TABLE ASSY	
1- 7.	BT311464	△ TRANS POWER CLT-11	U
1- 8.	BT311470	△ TRANS POWER CLT-12	J
1- 9.	BT311488	△ TRANS POWER CLT-13	E
1-10.	BT311475	△ TRANS POWER CLT-14	A
1-11.	BT311505	△ TRANS POWER CLT-15	C
1-12.	BT311494	△ TRANS POWER CLT-16	B, S
1-13.	BZT2010A070A	DETECTION TAPE GUIDE BLK CS-M40R	
1-14.	EC300034	C S-FIX H ECR-CA100H12 9.0-100	
1-15.	ED330987	△ D SILICON RB152 200/1.5A	
1-16.	ED308952	D GERMA V 1K34A-LR F07	
1-17.	ED329006	D LED GL-9NG12 GRN	
1-18.	ED322772	D LED SLP-155D-01 RED	
1-19.	ED328701	D LED SLP-455D-01 ORG	
1-20.	ED560913	D SILICON V IS2473VE	
1-21.	ED306109	D SILICON W03B 100/1.0A	
1-22.	ED329449	D ZENER H HZ18 3	
1-23.	ED319167	D ZENER H HZ6 C3	
1-24.	ED318859	D ZENER H HZ9 C2	
1-25.	EF668474	△ FUSE SEMKO T 250V 0.40A	E, B, S (F3)
1-26.	EF602550	△ FUSE SEMKO T 250V 1.25A	E, B, S (F2, F4)
1-27.	EF601964	△ FUSE SEMKO T 250V 1.60A	E, B, S (F1)
1-28.	EF309389	△ FUSE TSC A 250V 0.40A	U, J (F3)
1-29.	EF306949	△ FUSE TSC A 250V 1.25A	U, J (F2)
1-30.	EF311839	△ FUSE TSC A 250V 1.6A	U, J (F1)
1-31.	EF308848	△ FUSE TSC 125V 0.40A	C, A (F3)
1-32.	EF309392	△ FUSE TSC 125V 1.25A	C, A (F2)
1-33.	EF308847	△ FUSE TSC 125V 1.60A	C, A (F1)
1-34.	EI311959	IC HA12028	
1-35.	EI312179	IC LM1111B	
1-36.	EI311710	IC LM6402	
1-37.	EJ324276	DIN J TCS46BD-01-111 P 8P	
1-38.	EJ310567	SOCKET INLET 0378PC-GS E 2P	
1-39.	EL309960	PL CORD 24.0V 50MA 450/450	IN902, 903
1-40.	EL200096	PL LEAD 3.5V 100MA	IN1
1-41.	EM329497	IND LE LT-1003 GRAPH	
1-42.	EP318644	△ SOLENOID 1240PLT 27V	
1-43.	EP318645	△ SOLENOID 1240PLT 27V	
1-44.	EP318648	RELAY LEAD LAB2NS 2NO 6V	
1-45.	ER318647	△ R FUSE ERD2FC 1/4W 4R7J	
1-46.	ER200595	△ R FUSE ERD2FC 1/4W 5R6J	
1-47.	ER328490	FILTER DB D07-001K 19KHZ	
1-48.	ER328491	FILTER DB D07-003K 100KHZ	
1-49.	ER200972	R FUSE ERD2FC 1/4W 33ROG	
1-50.	ES201804	SW LEAF BSW-47PBC 01-1 NC	SW902

Ref. No.	Parts No.	Description	Note
1-51.	ES201805	SW LEAF BSW-47PC 01-1 NC	SW903
1-52.	ES201314	SW LEVER 00430408 2-04-03S	
1-53.	ES321274	SW LEVER 63349 2-06-03S	
1-54.	ES312234	SW PUSH SDL-1P 01-1 E	
1-55.	ES312235	SW PUSH SDL-1P 01-1 J	
1-56.	ES312238	SW PUSH SDL-1P 01-1 UC	
1-57.	ES310836	SW ROTARY SRU1023S 1-02-03S	
1-58.	ES328416	SW SLIDE SSB02385 2-02-03S	SW901
1-59.	ES283072	SW SLIDE SSC22LP 2-02-02N	
1-60.	ES311975	SW SOLENOID R8150050 27V 10-2W	
1-61.	ET311977	PHOTO SENSOR SPI-201	
1-62.	ET200558	TR 2SA1115 E, F	
1-63.	ET324134	TR 2SA984K E, F	
1-64.	ET328438	TR 2SB808-V F, G	
1-65.	ET402682	TR 2SC1061 C	
1-66.	ET317919	TR 2SC1061 C, D	
1-67.	ET603257	TR 2SC1312S G, H	
1-68.	ET308954	TR 2SC1844 E, F	
1-69.	ET310920	TR 2SC1846 R, S	
1-70.	ET309353	TR 2SC2274 E, F	
1-71.	ET200985	TR 2SC2603 F, G	
1-72.	ET328437	TR 2SD1012-V F, G	
1-73.	ET328868	TR 2SD1012-V G, H	
1-74.	ET307349	TR 2SD794 P, Q	
1-75.	EV315542	R S-FIX H D8 3P 103	
1-76.	EV315753	R S-FIX H D8 3P 203	
1-77.	EV322417	R S-FIX H D8 3P 303	
1-78.	EV315540	R S-FIX H D8 3P 502	
1-79.	EV315541	R S-FIX H D8 3P 503	
1-80.	EV475470	R S-FIX V V8K1-1 3P 103	
1-81.	EV329416	VR ROTARY 16P11 × OR 15A503 15A503	
1-82.	EZ328406	OSC CE CSB400A 0.4 MHZ	
1-83.	HE325859	HEAD E HF213131 C	
1-84.	HP311634	HEAD R/P RP-5042-CM-0510 C	
1-85.	MB314317	BELT CAPSTAN	
1-86.	MB314722	BELT COUNTER	
1-87.	MC312119	COUNTER MP-390-474	
1-88.	MC312120	COUNTER MP-390-475	(BL)
1-89.	MIB601782	FLYWHEEL (A) PART	
1-90.	MIB601783	FLYWHEEL (B) PART	
1-91.	MV328322	MAIN CASE	
1-92.	MZ283140	SOCKET SELECTER X-17238 6P	
1-93.	TCT2010D090A	PINCH ROLLER (L) BLK CS-M40R	
1-94.	TCT2010D100A	PINCH ROLLER (R) BLK CS-M40R	

2. HEAD BASE BLOCK

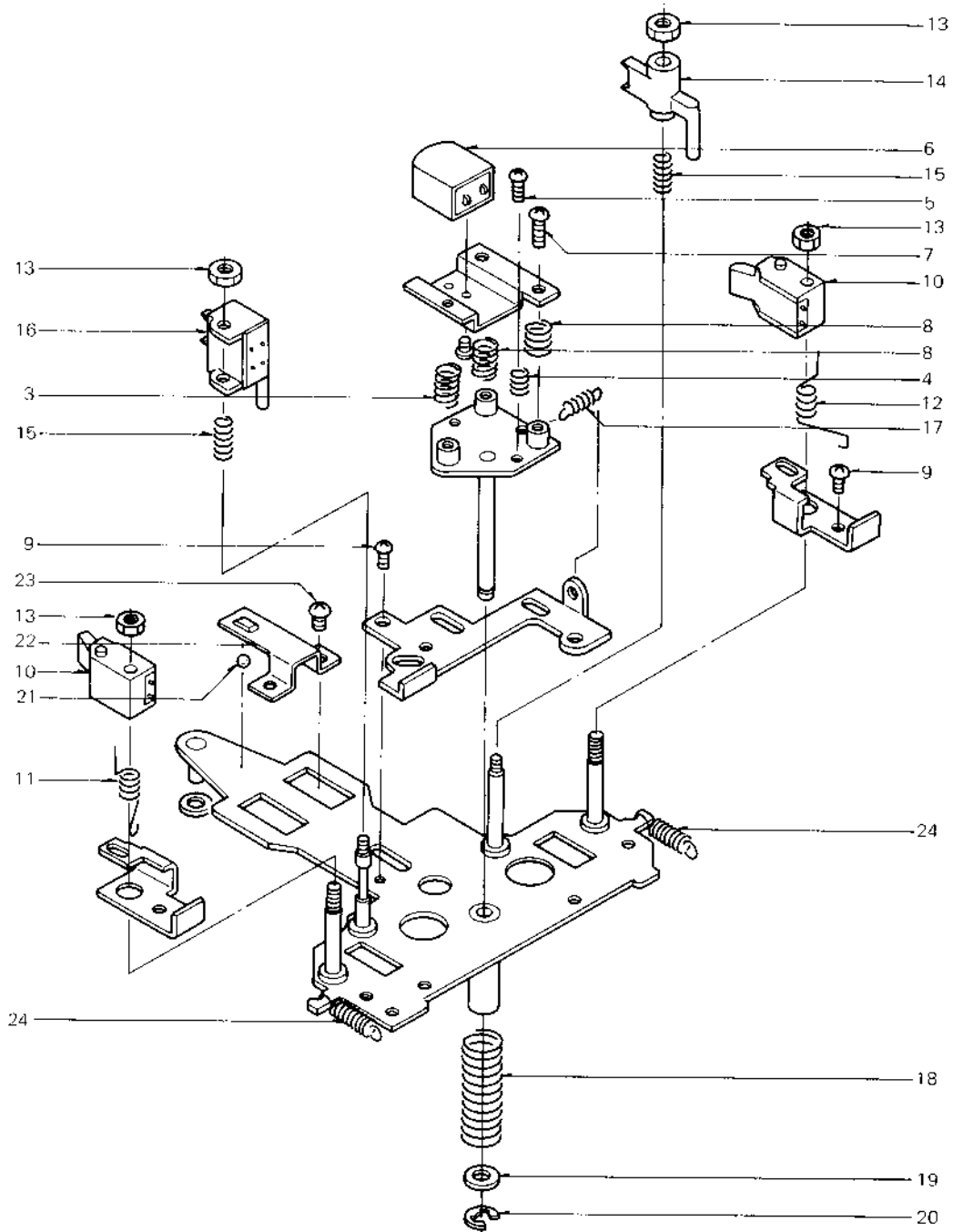

HEAD BASE BLOCK

Ref. No.	Parts No.	Description	Ref. No.	Parts No.	Description
2-1x	BHT2022A110A	HEAD BASE BLK CS-F33R	2-14	HZ313313	TAPE GUIDE
2-2x	ZS201407	PAN23 × 03STL CMT	2-15	ZG313314	ADJUST SPRING
2-3	ZG369088	ANGLE ADJUST SPRING	2-16	BZT2010A070A	DETECTION TAPE GUIDE BLK CS-M40R
2-4	ZG402895	CS ANGLE ADJUST SPRING	2-17	ZG330078	SP T2-3.2/0.2-9.0 T2-038
2-5	ZS465298	PAN23 × 10STL CMT	2-18	ZG313960	SP PUSH
2-6	HP311634	HEAD R/P RP-5042-CM-0510 C	2-19	ZW550642	PW31 × 0B0 × 050STL CMT
2-7	ZS608106	PAN20 × 06STL CMT	2-20	ZW270088	RING E 190SUP CMT
2-8	ZG328305	ANGLE SPRING	2-21	MV357208	STEEL BALL D2
2-9	ZS592378	PAN26 × 03STL CMT	2-22	MH314340	HEAD HOLDER
2-10	HE325859	HEAD E HF213131 C	2-23	ZS592378	PAN26 × 03STL CMT
2-11	ZG313316	ERASE HEAD SPRING (A)	2-24	ZG312946	SP T1-3.2/0.29-16.0 T1-062
2-12	ZG313874	ERASE HEAD SPRING (B)	2-25x	ZW328682	PW31 × 070 × 050PBR
2-13	ZW618884	N20STL CMT 1			

When ordering parts, please quote Parts Number, Description and Model Number.

3. REEL BASE BLOCK

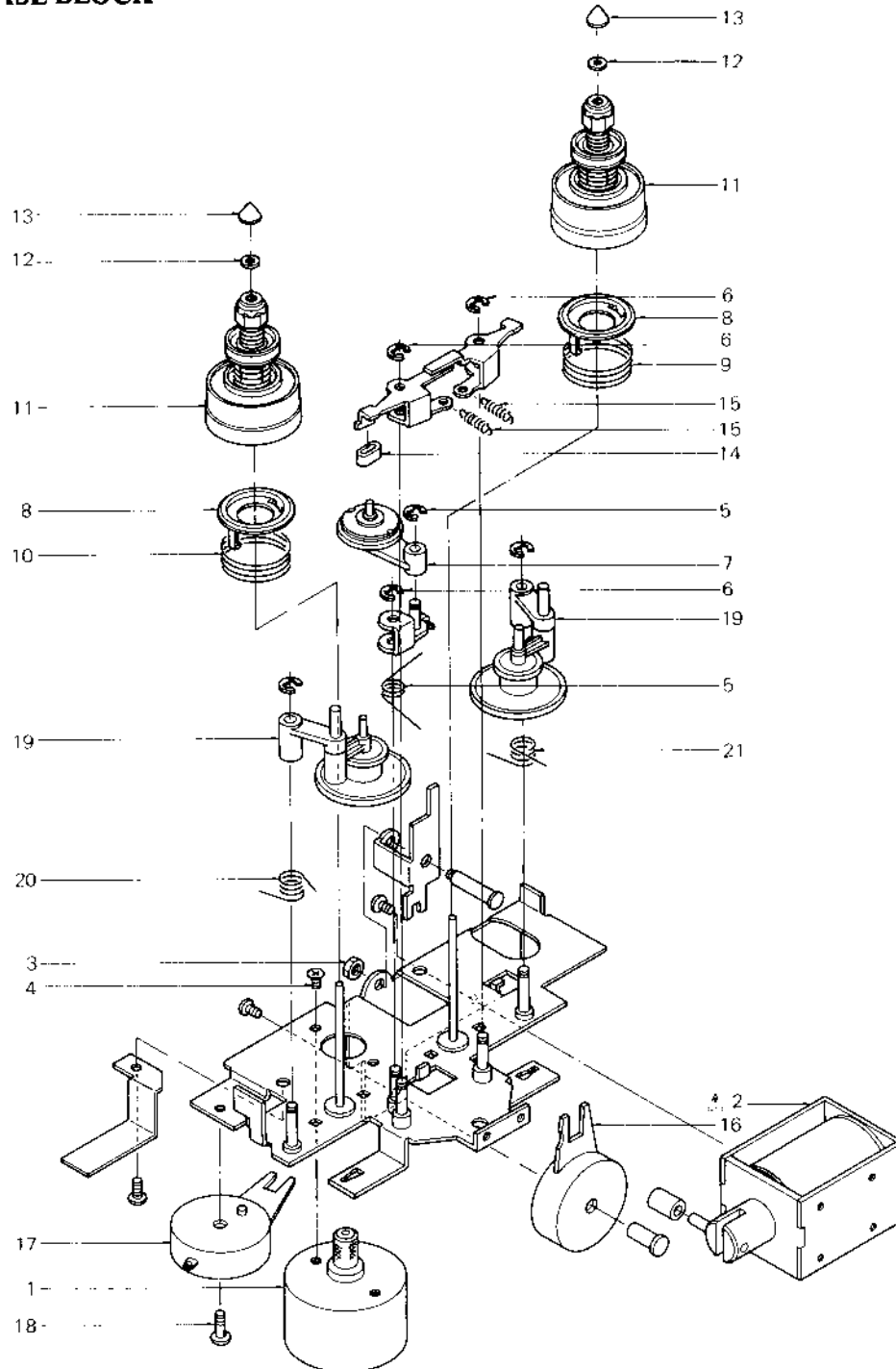

REEL BASE BLOCK

Ref. No.	Parts No.	Description	Ref. No.	Parts No.	Description
REEL MOTOR BLOCK			3-9	ZG328366	BT SPRING
3-1	BMT2016A320A	△ REEL MOTOR BLK (W/PULLEY) GX-F35	3-10	ZG330049	SP PUSH BACK TENSION
PLUNGER ASSY			3-11	BR328424	TAKE-UP REEL TABLE ASSY
3-2	EP318645	△ SOLENOID 1240PLT 27V	3-12	ZS330073	PW21 × 040 × 020
REEL BASE BLOCK			3-13	MT305793	REEL CAP
3-3	ZW516993	N30STL CMT 1	3-14	MB282104	BRAKE RUBBER
3-4	ZS430413	CTS26 × 04STL CMT	3-15	ZG321534	SP T2-3.2/0.29-12.5 T2-060
3-5	ZG314747	SP TORSION IDLER	3-16	BZT2022A260A	DAMPER (C) ASSY CS-F33R
3-6	ZW270088	RING E 190SUP CMT	3-17	BZT2016A330A	DAMPER (B) ASSY GX-F35
3-7	BI312117	REW IDLER ASSY	3-18	ZS479474	PAN26 × 05STL CMT
3-8	TC328365	BT DRUM	3-19	BI312118	TAKE-UP IDLER ASSY
			3-20	ZG314876	SP TORSION IDLER CLAMP (A)
			3-21	ZG314749	SP TORSION IDLER CLAMP (B)

When ordering parts, please quote Parts Number, Description and Model Number.

4. MECHA FRAME BLOCK

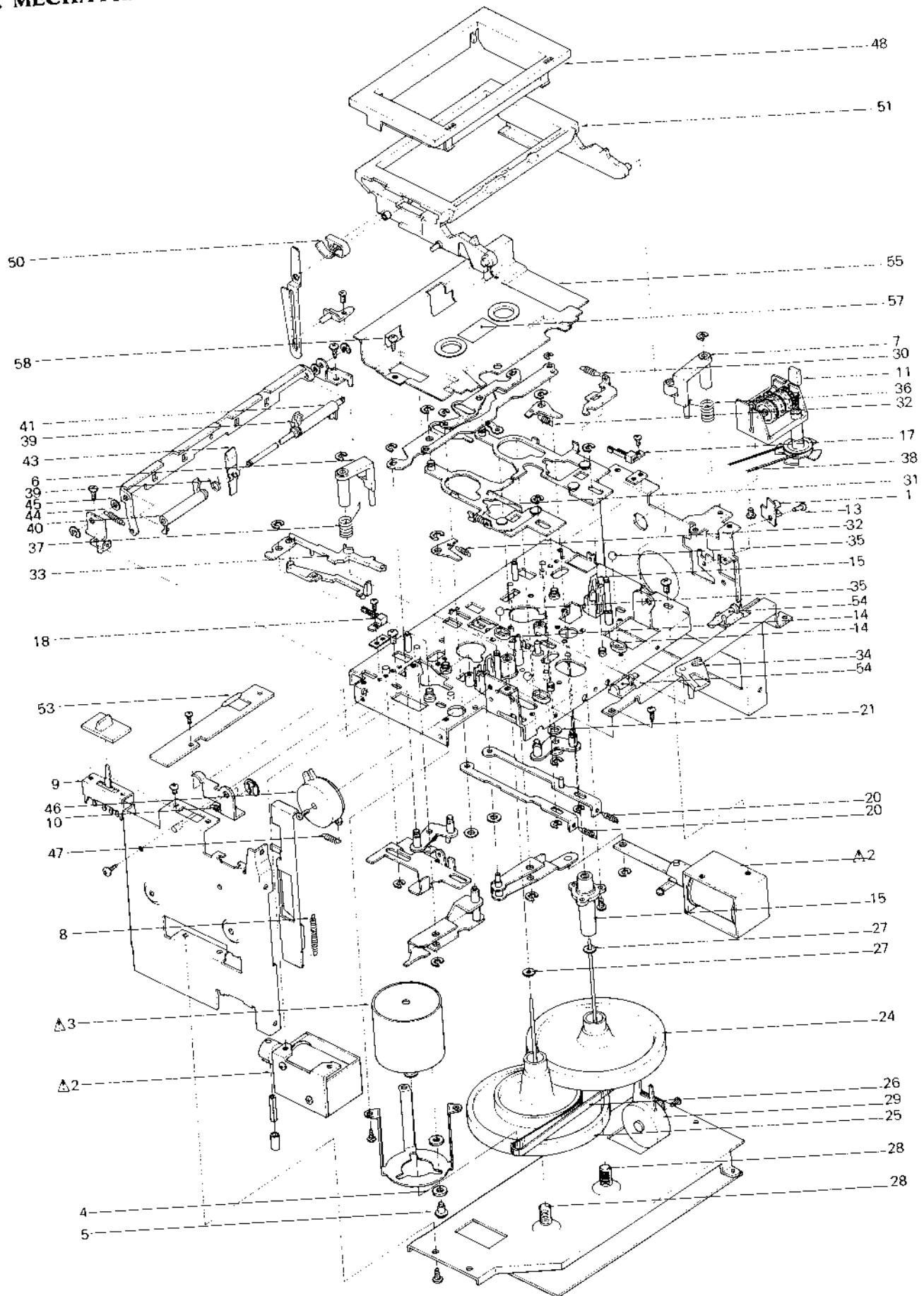

MECHA FRAME BLOCK

Ref. No.	Parts No.	Description
DETECTION P.C. BOARD BLOCK		
4-1	ET311977	PHOTO SENSOR SP1-201
PLUNGER BLOCK		
4-2	EP318644	SOLENOID 1240PLT 27V
MOTOR BLOCK		
4-3	BMT2022A080A	MOTOR (PULLEY) BLK CS-F33R
4-4	MB282778	RUBBER BUSH
4-5	ZS321338	MOTOR SCREW
PINCH ROLLER (L) BLOCK		
4-6	TCT2010D090A	PINCH ROLLER (L) BLK CS-M40R
PINCH ROLLER (R) BLOCK		
4-7	TCT2010D100A	PINCH ROLLER (R) BLK CS-M40R
MECHA FRAME BLOCK		
4-8	ZG318204	SP T2-3.2/0.29-16 T2-062
4-9	ES328416	SW SLIDE SSB02385 2-02-03S (SW901)
4-10	ZG312944	SP T1-3.2/0.29-12.5 T1-060
4-11	MC312119	COUNTER MP-390-474
4-12x	MC312120	COUNTER MP-390-475 (BL)
4-13	ZW312121	RV NYL26 × 042 BL
4-14	MS302191	BALL GUIDE
4-15	MV328322	MAIN CASE
4-16	TC314156	HOLDER CASSETTE
4-17	ES201804	SW LEAF BSW-47PBC 01-1 NC (SW902)
4-18	ES201805	SW LEAF BSW-47PC 01-1 NC (SW903)
4-19	ZW438928	PW31 × 048 × 020PBR
4-20	ZG312942	SP T1-3.2/0.29-10.0 T1-058
4-21	ZW259773	PW41 × 070 × 050NYL
4-22	ZW649991	PW41 × 070 × 030PBR
4-23x	ZG314069	SP PLATE HEAD BASE
4-24	MIB601782	FLYWHEEL (A) PART
4-25	MIB601783	FLYWHEEL (B) PART
4-26	MB314317	BELT CAPSTAN
4-27	ZW694798	PW31 × 070 × 020TFL
4-28	ZS302318	HOLD SCREW
4-29	BZT2016A330A	DAMPER (B) ASSY GX-F35
4-30	ZG318083	SP PULL CLAMP
4-31	ZG318083	SP PULL CLAMP
4-32	ZG310531	SP T 1-4.0/0.4-12.5 T1-109
4-33	ML314337	LEVER EJECT CHECK
4-34	MR314339	CAM HEAD CHANGE
4-35	MV269965	BALL 400STL
4-36	ZG310694	PINCH ROLLER RETURN SPRING (A)
4-37	ZG310695	PINCH ROLLER RETURN SPRING (B)
4-38	MB314722	BELT COUNTER
4-39	ZG314464	SP TORSION DETECTOR
4-40	ML314404	LEVER DETECTION (A)
4-41	ML314384	LEVER DETECTION (B)
4-42	ZG314481	SP PLATE CASSETTE HOLDER
4-43	TC328312	CASSETTE HOLDER
4-44	ZG318080	SP PULL EJECT
4-45	ZW438928	PW31 × 048 × 020PBR
4-46	BZT2016A290A	DAMPER (A) ASSY GX-F35
4-47	ZG318228	SPT2-3.2/0.29-14 T2-061
4-48	TC328350	CASSETTE HOLDER
4-49x	TC328351	CASSETTE HOLDER (BL)
4-50	ZG321487	MOLD SPRING
4-51	SZ316010A	LID HOLDER
4-52x	SZ316010B	LID HOLDER (BL)
4-53	EL200096	PL LEAD 3.5V 100MA (IN1)
4-54	EL309960	PL CORD 24.0V 50MA 450/450 (IN902, 903)
4-55	SZ314713A	LID DECORATION PLATE
4-56x	SZ314713B	LID DECORATION PLATE (BL)
4-57	TC317366	REFLECTOR PLATE (B)
4-58	ZS609118	T2PAN30 × 05STL CMT

When ordering parts, please quote Parts Number, Description and Model Number.

**5. GROUP (I) P.C BOARD
(T2022A5100, T2022A5101) BLOCK**

Ref. No.	Parts No.	Description
5-1	BAT2022A130A	GROUP (I) PC BLK CS-F33R (U) (INCLUDING PRE AMP PCB AND VR PCB)
5-2	BAT2022A130B	GROUP (I) PC BLK CS-F33R (E) (INCLUDING PRE AMP PCB AND VR PCB)

PRE AMP P.C. BOARD (T2022A5100) BLOCK

5-IC1	EI312179	IC LM1111B
5-IC2	EI311959	IC HA12028
5-TR1, 2	ET603257	TR 2SC1312S G, H
5-TR3, 4	ET328437	TR 2SD1012-V F, G
5-TR5	ET309353	TR 2SC2274 E, F
5-TR6	ET328437	TR 2SD1012-V F, G
5-TR7	ET308954	TR 2SC1844 E, F
5-TR8	ET328868	TR 2SD1012-V G, H
5-TR9	ET200985	TR 2SC2603 F, G
5-TR10	ET603257	TR 2SC1312S G, H
5-TR11 to 13	ET200985	TR 2SC2603 F, G
5-TR14	ET309353	TR 2SC2274 E, F
5-TR15, 16	ET200985	TR 2SC2603 F, G
5-TR17	ET603257	TR 2SC1312S G, H
5-TR18	ET328868	TR2SD1012-V G, H
5-TR19	ET317919	TR 2SC1061 C, D
5-TR20, 21	ET309353	TR 2SC2274 E, F
5-TR22	ET200985	TR 2SC2603 F, G
5-TR23	ET310920	TR 2SC1846 R, S
5-TR24	ET200985	TR 2SC2603 F, G
5-D1	ED308952	D GERMA V 1K34A-LR F07
5-D2 to 4	ED560913	D SILICON V 1S2473VE
5-D5, 6	ED308952	D GERMA V 1K34A-LR F07
5-D7	ED318859	D ZENER H HZ9 C2
5-D9	ED306109	D SILICON W03B 100/1.0A
5-D10 to 12	ED560913	D SILICON V 1S2473VE
5-VC1, 2	EC300034	C S-FIX H ECR-CA100H12 9.0-100
5-FR1, 2	ER200595	△ R FUSE ERD2FC 1/4W 5R6J
5-FR3	ER318647	△ R FUSE ERD2FC 1/4W 4R7J
5-J1	EJ321328	PHONE J HLJ0345-010 2 × 3P
5-J2	EJ316156	PHONE J 3P HLJ0315-020 6.3
5-J3	EJ308986	PIN J 1784P1782 P 4P (U.J.C.A)
5-J3	EJ308985	JACK PLATE DIN, PIN JACK 4P (E.B.S)
5-SW1	EB283072	SW SLIDE SSC22LP 2-02-02N (E.B.S)
5-SW2	ES201314	SW LEVER 00430408 2-04-03S
5-SW3	ES321274	SW LEVER 63349 2-06-03S
5-SW4	ES311975	SW SOLENOID R8150050 27V 10-2W
5-VR1	EV315540	R S-FIX H D8 3P 502
5-VR2, 3	EV315541	R S-FIX H D8 3P503
5-VR4	EV322417	R S-FIX H D8 3P 303
5-VR5	EV315541	R S-FIX H D8 3P 503
5-VR6	EV315542	R S-FIX H D8 3P 103
5-VR7	EV315753	R S-FIX H D8 3P 203
5-RL1	EP318648	RELAY LEAD LAB2NS 2NO 6V
5-VL1	EO321336	COIL VARI 1 FE002 10MH
5-T1	EO311974	COIL OSC1 0322-1034-022 100 KHZ
5-FL1	ER328490	FILTER DB D07-001K 19 KHZ
5-FL2	ER328491	FILTER DB D07-003K 100KHZ
5-FL3, 4	EO315758	COIL TUN 1 100S-431 100KHZ
5-L1	EO330239	COIL FIX 1 FL09H 390UH J
5-C2	EC314997	C STY V SNP CQFS 391K 50DC
5-C3	EC315616	C STY V SNP CQFS 471K 50DC
5-C11	EC319634	C STY V SNP CQFS 561K 50DC
5-C36	EC315616	C STY V SNP CQFS 471K 50DC
5-C38	EC315616	C STY V SNP CQFS 471K 50DC
5-C53	EC318632	C STY V F05 CQF09 101K 50DC
5-C72	EC311880	C PP V F10 PFH 332K 630DC
5-C81	EC328856	C STY V F05 CQF09 331K 50DC
5-3	ZW263946	RV NYL40 × 050

VR. P.C BOARD (T2022A5101) BLOCK

5-VR1	EV329416	VR ROTARY 16P11 × OR 15A503 15A503
-------	----------	------------------------------------

**6. SYS. CON. P.C BOARD
(T2022B5120/T2022B5130) BLOCK**

Ref. No.	Parts No.	Description
6-1	BAT2022A120A	SYSCON PC BLK CS-F33R (U) (U,J,E,B,S)
6-2	BAT2022A120B	SYSCON PC BLK CS-F33R (C) (C, A)
6-IC1	EI311710	IC LM6402
6-TR1	ET200985	TR 2SC2603 F, G
6-TR2	ET324134	TR 2SA984K E, F
6-TR3	ET309353	TR 2SC2274 E, F
6-TR4, 5	ET200985	TR 2SC2603 F, G
6-TR6	ET324134	TR 2SA984K E, F
6-TR7	ET309353	TR 2SC2274 E, F
6-TR8, 9	ET200985	TR 2SC2603 F, G
6-TR10	ET324134	TR 2SA984K E, F
6-TR11	ET309353	TR 2SC2274 E, F
6-TR12	ET200985	TR 2SC2603 F, G
6-TR13	ET328437	TR 2SD1012-V F, G
6-TR14	ET328438	TR 2SB808-V F, G
6-TR15	ET328437	TR 2SD1012-V F, G
6-TR16	ET328438	TR 2SB808-V F, G
6-TR17 to 20	ET200985	TR 2SC2603 F, G
6-TR21	ET200558	TR2SA1115 E, F
6-TR22 to 24	ET200985	TR 2SC2603 F, G
6-TR25, 26	ET200558	TR 2SA1115 E, F
6-TR27 to 34	ET200985	TR 2SC2603 F, G
6-D1 to 6	ED306109	D SILICON W03B 100/1.0A
6-D9 to 12	ED560913	D SILICON V 1S2473VE
6-D13, 14	ED308952	D GERMA V 1K34A-LR F07
6-D15 to 20	ED560913	D SILICON V 1S2473VE
6-VR1	EV475470	R S-FIX V V8K1-1 3P 103
6-L1	EO669273	COIL FIX 2 FL5R200 18UH
6-X1	EZ328406	OSC CE CSB400A 0.4 MHZ
6-C9	EC306980	C STY V F05 500 221J 50DC
6-C10	EC306438	C STY V F05 500 101J 50DC

**7. POWER SUPPLY P.C BOARD
(T2022B5160/T2022B5170/T2022B5180/
T2022B5190) BLOCK**

Ref. No.	Parts No.	Description
7-1	BAT2022A151A	POWER PC BLK CS-F33R (U)
7-2	BAT2022A160B	POWER PC BLK CS-F33R (J)
7-3	BAT2022A160C	POWER PC BLK CS-F33R (C)
7-4	BAT2022A160D	POWER PC BLK CS-F33R (A)
7-5	BA-T2022A160E	POWER PC BLK CS-F33R (E)
7-6	BAT2022A160F	POWER PC BLK CS-F33R (B,S)
7-TR1	ET307349	△ TR 2SD794 P, Q
7-TR2	ET-200985	TR2SC2603 F, G
7-TR3	ET402682	△ TR 2SC1061 C
7-TR4	ET200985	TR 2SC2603 F, G
7-TR5	ET307349	△ TR 2SD794 P, Q
7-TR6	ET200985	TR 2SC2603 F, G
7-D1, 2	ED330987	△ D SILICON RB152 200/1.5A
7-D3	ED329449	D ZENER H HZ18 3
7-D4	ED319167	D ZENER H HZ6 C3
7-J1	EJ310567	△ SOCKET INLET 0378PC-GS E 2P (B, S)
7-SW1	ES312234	△ SW PUSH SDL-1P 01-1 E (U)
7-SW1	ES312235	△ SW PUSH SDL-1P 01-1 J (J)
7-SW1	ES312238	△ SW PUSH SDL-1P 01-1 UC (C,A)
7-SW1	ES312234	△ SW PUSH SDL-1P 01-1 E (E,B,S)
7-VS1	MZ283140	△ SOCKET SELECTER X-17238 6P (U)
7-FR1	ER200972	△ R FUSE ERD2FC 1/4W 33ROG
7-C1	EC330308	△ C MMY V ECQUF 103M 250AC (U)
7-C1	EC320548	△ C CE V F 103Z 250AC (J, A)
7-C1	EC314688	△ C CE V FZ 103P 125AC (C)
7-C1	EC330308	△ C MMY V ECQUF 103M 250AC (E,B,S)
7-C4	EC316230	C EC V CUT H222M 35DC

8. LED P.C BOARD (T2022D5200) BLOCK

Ref. No.	Parts No.	Description
8-D1	ED322772	D LED SLP-155D-01 RED
8-D2	ED328701	D LED SLP-455D-01 ORG

**9. OPERATION (C) P.C BOARD
(T2022C5084) BLOCK**

Ref. No.	Parts No.	Description
9-J1	EJ324276	DIN J TCS4680-01-111 P 8P

**10. OPERATION (A) P.C BOARD
(T2022C5081) BLOCK**

Ref. No.	Parts No.	Description
10-D1 to 3	ED329006	D LED GL-9NG12 GRN

**11. OPERATION (B) P.C. BOARD
(T2022C5083) BLOCK**

Ref. No.	Parts No.	Description
11-SW4	ES310836	SW ROTARY SRU1023S 1-02-03S

12. ASSEMBLY BLOCK

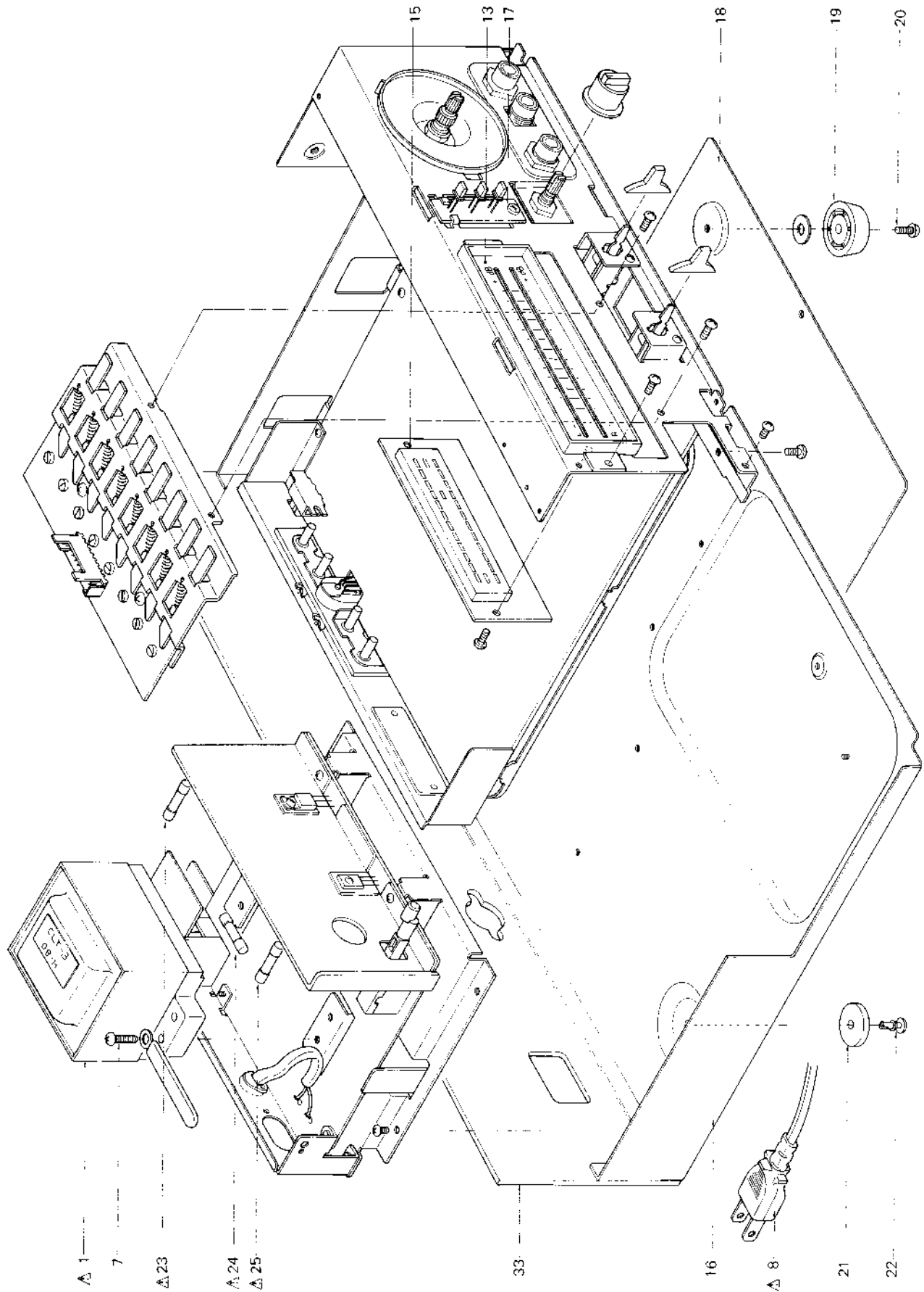

ASSEMBLY BLOCK

Ref. No.	Parts No.	Description
POWER BLOCK		
12-1	BT311464	△ TRANS POWER CLT-11 (U)
12-2x	BT311470	△ TRANS POWER CLT-12 (J)
12-3x	BT311505	△ TRANS POWER CLT-15 (C)
12-4x	BT311475	△ TRANS POWER CLT-14 (A)
12-5x	BT311488	△ TRANS POWER CLT-13 (E)
12-6x	BT311494	△ TRANS POWER CLT-16 (B, S)
12-7	ZS201872	ST BID40 × 25STL CMT
12-8	EW306428	△ AC CORD 2 CORES KP-205A, VFFUCJ (J)
12-9x	EW306427	△ AC CORD 2 CORES KP-211, VFFJ (J)
12-10x	EW305691	△ AC CORD 2 CORES KP-8, SPT-1 UC (C, A)
12-11x	EW201796	△ AC CORD 2 CORES KP-419C, LTCE-2F E (E)
12-12x	SZ631945	△ STRAIN RELIEF SR-4N-4 (U, J, C, A)

LED METER BLOCK

12-13	SE316000A	ESCUTCHEON LED METER
12-14x	SE316000B	ESCUTCHEON LED METER (BL)
12-15	EM329497	IND LE LT-1003 GRAPH

ASSEMBLY BLOCK

12-16	SP315350	CHASSIS BOTTOM
12-17	ZS329460	GRADUATED SCREW
12-18	SP315391	COVER BOTTOM PLATE
12-19	SA202118	FOOT
12-20	ZS494842	T2BID30 × 08STL CMT PW080
12-21	SA313811	RUBBER FOOT
12-22	ZW231030	RV NYL30 × 045 BL
12-23	EF311839	△ FUSE TSC A 250V 1.6A (U, J) (F1)
12-24	EF306949	△ FUSE TSC A 250V 1.25A (U, J) (F2)
12-25	EF309389	△ FUSE TSC A 250V 0.40A (U, J) (F3)
12-26x	EF308847	△ FUSE TSC 125V 1.60A (C, A) (F1)
12-27x	EF309392	△ FUSE TSC 125V 1.25A (C, A) (F2)
12-28x	EF308848	△ FUSE TSC 125V 0.40A (C, A) (F3)
12-29x	EF601964	△ FUSE SEMKO T 250V 1.60A (E, B, S) (F1)
12-30x	EF602550	△ FUSE SEMKO T 250V 1.25A (E, B, S) (F2)
12-31x	EF668474	△ FUSE SEMKO T 250V 0.40A (E, B, S) (F3)
12-32x	EF602550	△ FUSE SEMKO T 250V 1.25A (E, B, S) (F4)
12-33	SP316626B	PANEL REAR BOARD CS-F33R (U)
12-34x	SP316626F	PANEL REAR BOARD CS-F33R (J)
12-35x	SP316626D	PANEL REAR BOARD CS-F33R (C)
12-36x	SP316626E	PANEL REAR BOARD CS-F33R (A)
12-37x	SP316626C	PANEL REAR BOARD CS-F33R (E)
12-38x	SP316626A	PANEL REAR BOARD CS-F33R (B, S)
12-39x	ZS225134	T2PAN30 × 10STL CMT PW080

13. FINAL ASSEMBLY BLOCK

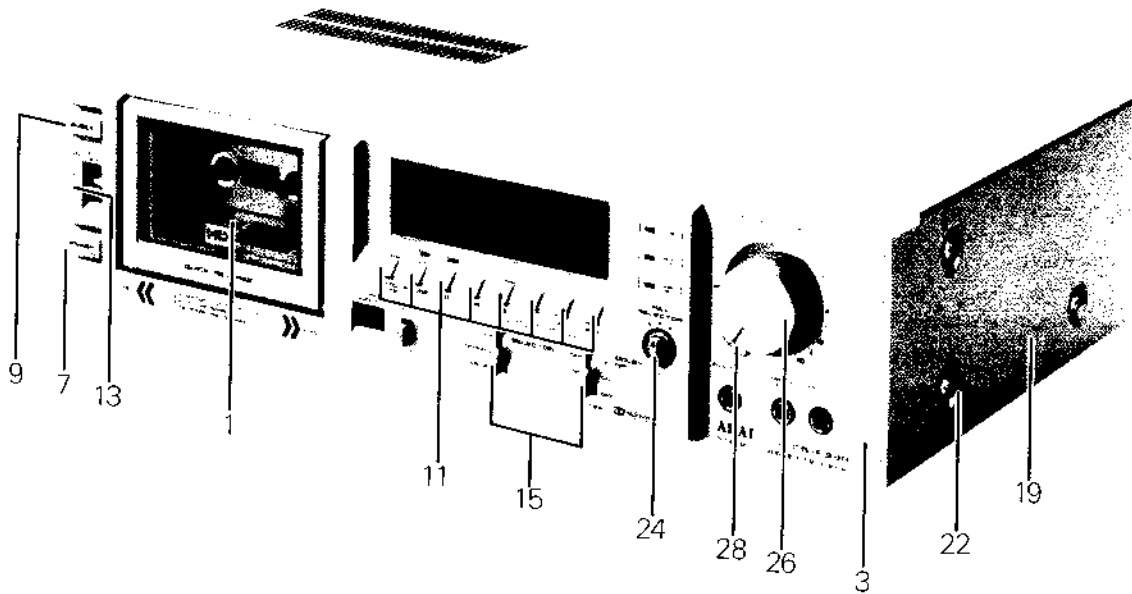

FINAL ASSEMBLY BLOCK

Ref. No.	Parts No.	Description	Ref. No.	Parts No.	Description
LID PANEL BLOCK			FINAL ASSEMBLY BLOCK		
13-1	BDT2022A240A	LID PANEL ASSY CS-F33R	13-13	SK315959A	KNOB SLIDE
13-2x	BDT2022A240B	LID PANEL ASSY CS-F33R-BL	13-14x	SK315959B	KNOB SLIDE (BL)
FRONT PANEL BLOCK			13-15	SK329033	LEVER KNOB (A)
13-3	BDT2022A230A	FRONT PANEL BLK CS-F33R (U) (U,J,C,A,PX)	13-16x	SK329034	LEVER KNOB (BL)
13-4x	BDT2022A230B	FRONT PANEL BLK CS-F33R (J) (E,B,S)	13-17x	SE315999A	MASK KNOB
13-5x	BDT2022A230C	FRONT PANEL BLK CS-F33RBL (U) (U,J,C,A)	13-18x	SE315999B	MASK KNOB (BL)
13-6x	BDT2022A230D	FRONT PANEL BLK CS-F33RBL (E) (E,B,S)	13-19	BC328685	UPPER COVER (C)
13-7	SK317468A	KNOB PUSH (A)	13-20x	BC328687	UPPER COVER (C-BL) (U,J,C,E,B,S,PX)
13-8x	SK317468B	KNOB PUSH (A)-BL	13-21x	BC328686	UPPER COVER (D) (A)
13-9	SK317468C	KNOB PUSH (B)	13-22	ZS315878	XST BID40 × 08STL N13
13-10x	SK317468D	KNOB PUSH (B)-BL	13-23x	ZS310588	XST BID40 × 08STL BNI (A,BL)
13-11	SK317506A	KNOB OPERATION	13-24	SK325782	KNOB (C)
13-12x	SK317506B	KNOB OPERATION (BL)	13-25x	SK325783	KNOB (C-BL)
			13-26	SK325785	DOUBLE KNOB (UPPER)
			13-27x	SK325786	DOUBLE KNOB (UPPER-BL)
			13-28	SK325787	DOUBLE KNOB (LOWER)
			13-29x	SK325788	DOUBLE KNOB (LOWER-BL)
			13-30x	BC330054	CASE WOOD (PX)
			13-31x	SA202118	FOOT (PX)
			13-32x	ZW326042	PW35 × 070 × 050STL CMT (PX)
			13-33x	ZS414268	TITRS35 × 10STL CMT (PX)
			13-34x	ZW381881	PW41 × 130 × 100STL CMT (PX)
			13-35x	ZS330057	ST BID40 × 22STL CMT (PX)
			13-36x	ZW305013	RV POP32 (A)

When ordering parts, please quote Parts Number, Description and Model Number.

INDEX

Parts No.	Ref. No. & Symbol No.	Parts No.	Ref. No. & Symbol No.	Parts No.	Ref. No. & Symbol No.	Parts No.	Ref. No. & Symbol No.
BAT2022A120A	6-1	EI311959	5-JC2	EV315540	5-VR1	ZG310694	4-36
BAT2022A120B	6-2	EI312179	5-IC1	EV315541	5-VR2,3	ZG310695	4-37
BAT2022A130A	5-1	EJ308985	5-J3	EV315541	5-VR5	ZG312942	4-20
BAT2022A130B	5-2	EJ308986	5-J3	EV315542	5-VR6	ZG312944	4-10
BAT2022A151A	7-1	EJ310567	7-J1	EV315753	5-VR7	ZG312946	2-24
BAT2022A160B	7-2	EJ316156	5-J2	EV322417	5-VR4	ZG313314	2-15
BAT2022A160C	7-3	EJ321328	5-J1	EV329416	5-VR1	ZG313316	2-11
BAT2022A160D	7-4	EJ324276	9-J1	EV475470	6-VR1	ZG313874	2-12
BAT2022A160E	7-5	EL200096	4-53	EW201796	12-11x	ZG313960	2-18
BAT2022A160F	7-6	EL309960	4-54	EW305691	12-10x	ZG314069	4-23x
BC328685	13-19	EM329497	12-15	EW306427	12-9x	ZG314464	4-39
BC328686	13-21x	EO311974	5-T1	EW306428	12-8	ZG314481	4-42
BC328687	13-20x	EO315758	5-FL3,4	EZ328406	6-X1	ZG314747	3-5
BC330054	13-30x	EO321336	5-VL1	HE325859	2-10	ZG314749	3-21
BDT2022A230A	13-3	EO330239	5-L1	HP311634	2-6	ZG314876	3-20
BDT2022A230B	13-4x	EO669273	6-L1	HZ313313	2-14	ZG318080	4-44
BDT2022A230C	13-5x	EP318644	4-2	MB282104	3-14	ZG318083	4-30
BDT2022A230D	13-6x	EP318645	3-2	MB282778	4-4	ZG318083	4-31
BDT2022A240A	13-1	EP318648	5-RL1	MB314317	4-26	ZG318204	4-8
BDT2022A240B	13-2x	ER200595	5-FR1,2	MB314722	4-38	ZG318228	4-47
BHT2022A110A	2-1x	ER200972	7-FR1	MC312119	4-11	ZG321487	4-50
BI312117	3-7	ER318647	5-FR3	MC312120	4-12x	ZG321534	3-15
BI312118	3-19	ER328490	5-FL1	MH314340	2-22	ZG328305	2-8
BMT2016A320A	3-1	ER328491	5-FL2	MIB601782	4-24	ZG328366	3-9
BMT2022A080A	4-3	ES201314	5-SW2	MIB601783	4-25	ZG330049	3-10
BR328424	3-11	ES201804	4-17	ML314337	4-33	ZG330078	2-17
BT311464	12-1	ES201805	4-18	ML314384	4-41	ZG369088	2-3
BT311470	12-2x	ES283072	5-SW1	ML314404	4-40	ZG402895	2-4
BT311475	12-4x	ES310836	11-SW4	MR314339	4-34	ZS201407	2-2x
BT-311488	12-5x	ES311975	5-SW4	MS302191	4-14	ZS201872	12-7
BT311494	12-6x	ES312234	7-SW1	MT305793	3-13	ZS225134	12-39x
BT311505	12-3x	ES312234	7-SW1	MV269965	4-35	ZS302318	4-28
BZT2010A070A	2-16	ES312235	7-SW1	MV328322	4-15	ZS310588	13-23x
BZT2016A290A	4-46	ES312238	7-SW1	MV357208	2-21	ZS315878	13-22
BZT2016A330A	3-17	ES321274	5-SW3	MZ283140	7-VS1	ZS321338	4-5
BZT2016A330A	4-29	ES328416	4-9	SA202118	12-19	ZS329460	12-17
BZT2022A260A	3-16	ET200558	6-TR25,26	SA202118	13-31x	ZS330057	13-35x
EC300034	5-VC1,2	ET200558	6-TR21	SA313811	12-21	ZS330073	3-12
EC306438	6-C10	ET200985	5-TR9	SE-315999A	13-17x	ZS414268	13-33x
EC306980	6-C9	ET200985	5-TR11 to 13	SE315999B	13-18x	ZS430413	3-4
EC311880	5-C72	ET200985	5-TR15,16	SE316000A	12-13	ZS465298	2-5
EC314688	7-C1	ET200985	5-TR24	SE316000B	12-14x	ZS479474	3-18
EC314997	5-C2	ET200985	5-TR22	SK315959A	13-13	ZS494842	12-20
EC315616	5-C3	ET200985	6-TR22 to 24	SK315959B	13-14x	ZS592378	2-23
EC315616	5-C36	ET200985	6-TR17 to 20	SK317468A	13-7	ZS592378	2-9
EC315616	5-C38	ET200985	6-TR27 to 34	SK317468B	13-8x	ZS608106	2-7
EC316230	7-C4	ET200985	6-TR1	SK317468C	13-9	ZS609118	4-58
EC318632	5-C53	ET200985	6-TR4,5	SK317468D	13-10x	ZW231030	12-22
EC319634	5-C11	ET200985	6-TR8,9	SK317506A	13-11	ZW259773	4-21
EC320548	7-C1	ET200985	6-TR12	SK317506B	13-12x	ZW263946	5-3
EC328856	5-C81	ET200985	7-TR2	SK325782	13-24	ZW270088	2-20
EC330308	7-C1	ET200985	7-TR6	SK325783	13-25x	ZW270088	3-6
EC330308	7-C1	ET200985	7-TR4	SK325785	13-26	ZW305013	13-36x
ED306109	5-D9	ET307349	7-TR1	SK325786	13-27x	ZW312121	4-13
ED306109	6-D1 to 6	ET307349	7-TR5	SK325787	13-28	ZW326042	13-32x
ED308952	5-D1	ET308954	5-TR7	SK325788	13-29x	ZW328682	2-25x
ED308952	5-D5,6	ET309353	5-TR5	SK329033	13-15	ZW381881	13-34x
ED308952	6-D13,14	ET309353	5-TR20,21	SK329034	13-16x	ZW438928	4-45
ED318859	5-D7	ET309353	5-TR14	SP315350	12-16	ZW438928	4-19
ED319167	7-D4	ET309353	6-TR11	SP315391	12-18	ZW516993	3-3
ED322772	8-D1	ET309353	6-TR3	SP316626A	12-38x	ZW550642	2-19
ED328701	8-D2	ET309353	6-TR7	SP316626B	12-33	ZW618884	2-13
ED329006	10-D1 to 3	ET310920	5-TR23	SP316626C	12-37x	ZW649991	4-22
ED329449	7-D3	ET311977	4-1	SP316626D	12-35x	ZW694798	4-27
ED330987	7-D1,2	ET317919	5-TR19	SP316626E	12-36x		
ED560913	5-D2 to 4	ET324134	6-TR6	SP316626F	12-34x		
ED560913	5-D10 to 12	ET324134	6-TR2	SZ314713A	4-55		
ED560913	6-D15 to 20	ET324134	6-TR10	SZ314713B	4-56x		
ED560913	6-D9 to 12	ET328437	5-TR6	SZ316010A	4-51		
EF306949	12-24	ET328437	5-TR3,4	SZ316010B	4-52x		
EF308847	12-26x	ET328437	6-TR15	SZ631945	12-12x		
EF308848	12-28x	ET328437	6-TR13	TCT2010D090A	4-6		
EF309389	12-25	ET328438	6-TR16	TCT2010D100A	4-7		
EF309392	12-27x	ET328438	6-TR14	TC314156	4-16		
EF311839	12-23	ET328868	5-TR8	TC317366	4-57		
EF601964	12-29x	ET328868	5-TR18	TC328312	4-43		
EF602550	12-30x	ET402682	7-TR3	TC328350	4-48		
EF602550	12-32x	ET603257	5-TR1,2	TC328351	4-49x		
EF668474	12-31x	ET603257	5-TR17	TC328365	3-8		
EI311710	6-IC1	ET603257	5-TR10	ZG310531	4-32		

SECTION 3

SCHEMATIC DIAGRAM

1. SCHEMATIC DIAGRAM OF ICs
2. CS-F33R No. 1620802A SCHEMATIC DIAGRAM
3. CS-F33R No. 1620803A SCHEMATIC DIAGRAM

HA12028

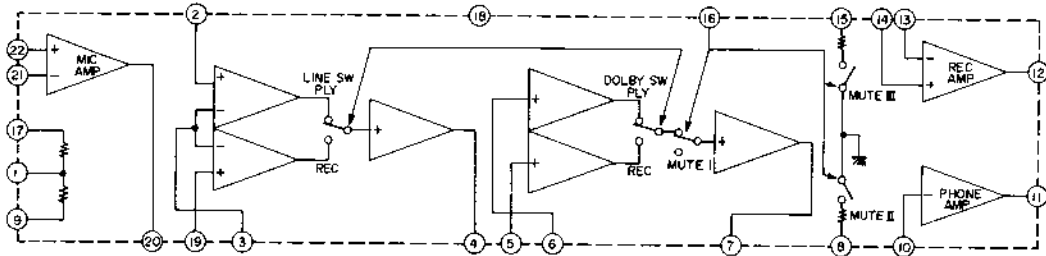

LM1111B

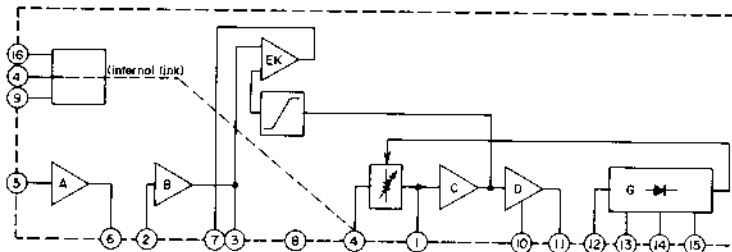

LM6402

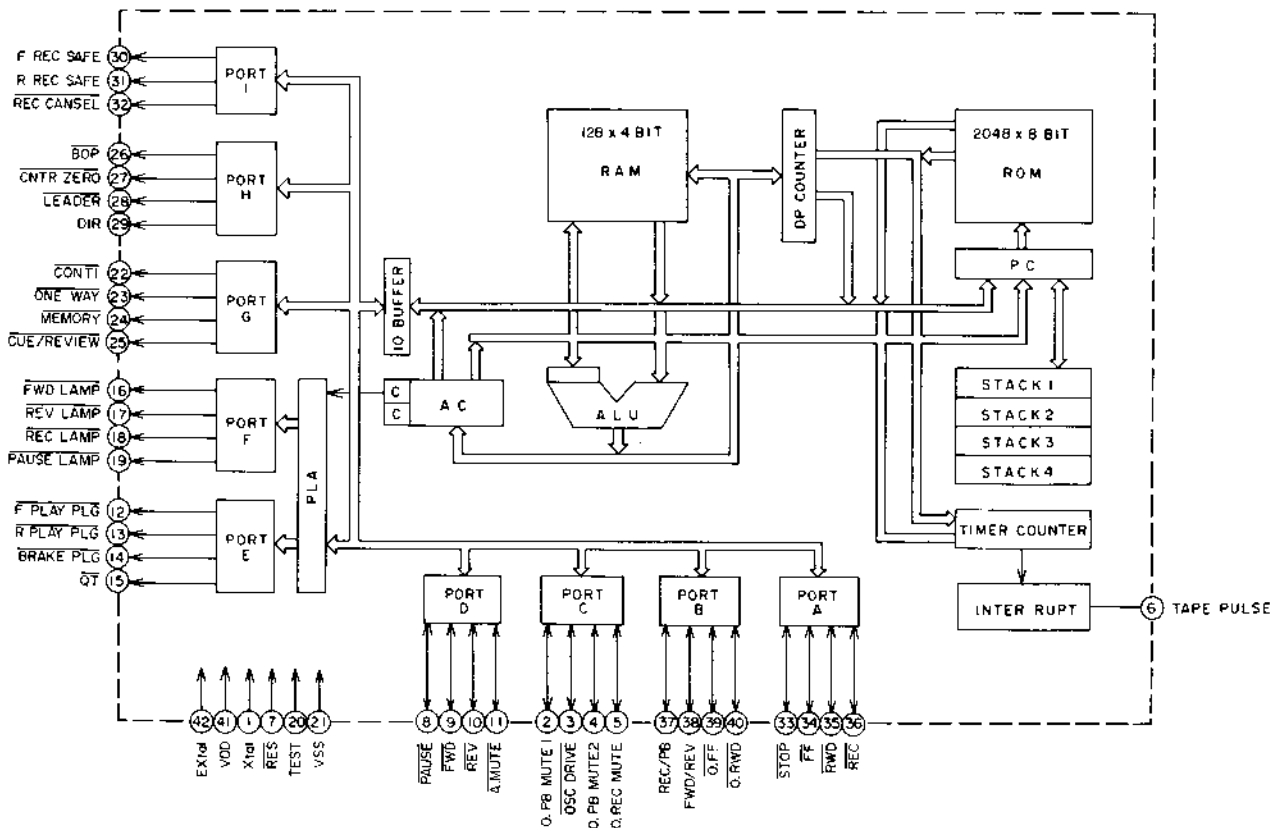

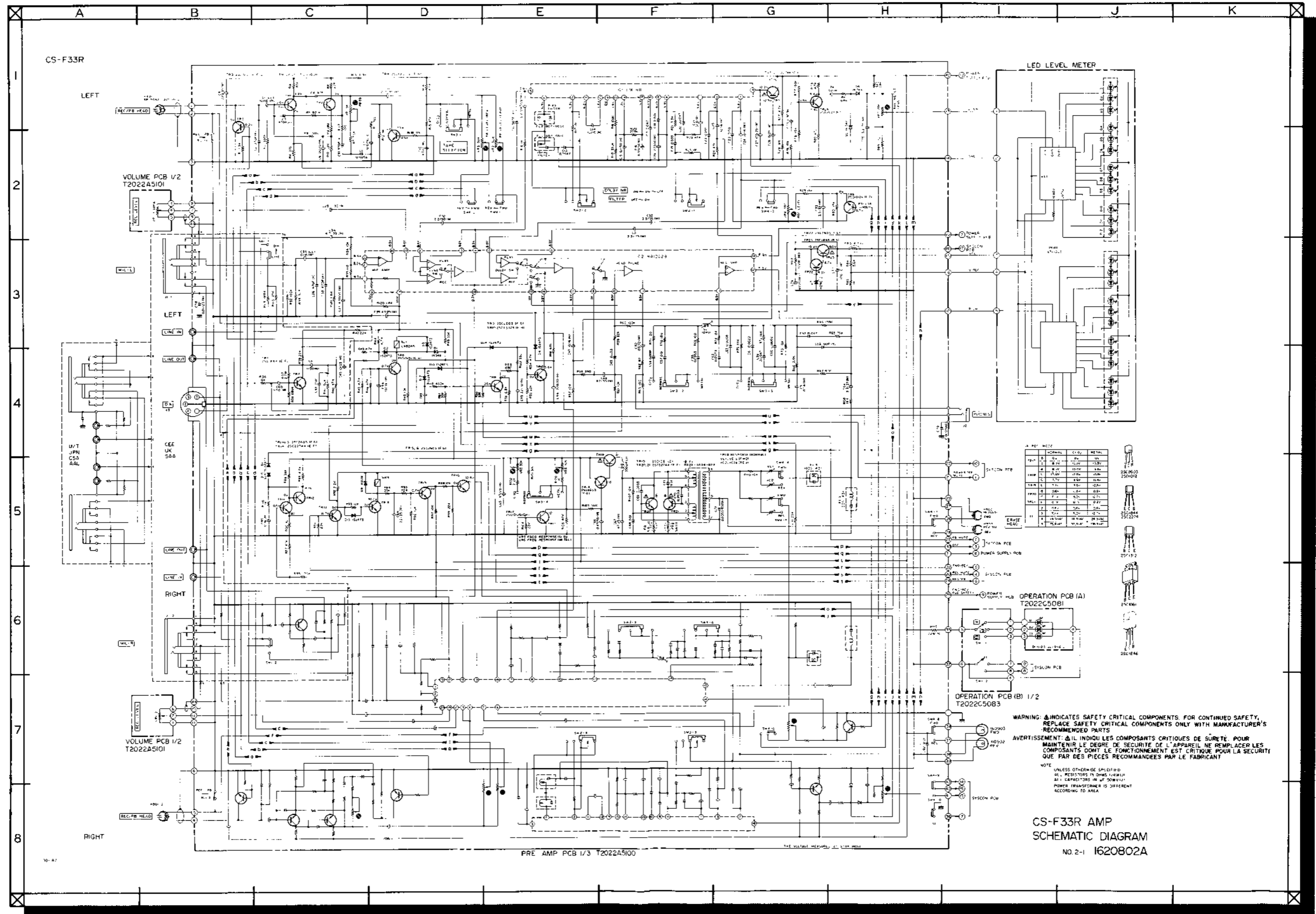

REF	DESCRIPTION	QTY	VALUE
1001	RES	10	10K
1002	RES	10	100K
1003	RES	10	1M
1004	RES	10	100K
1005	RES	10	10K
1006	RES	10	100K
1007	RES	10	1M
1008	RES	10	100K
1009	RES	10	10K
1010	RES	10	100K
1011	RES	10	1M
1012	RES	10	100K
1013	RES	10	10K
1014	RES	10	100K
1015	RES	10	1M
1016	RES	10	100K
1017	RES	10	10K
1018	RES	10	100K
1019	RES	10	1M
1020	RES	10	100K

WARNING: ⚠ INDICATES SAFETY CRITICAL COMPONENTS. FOR CONTINUED SAFETY, REPLACE SAFETY CRITICAL COMPONENTS ONLY WITH MANUFACTURER'S RECOMMENDED PARTS.

AVERTISSEMENT: ⚠ IL INDIQUE LES COMPOSANTS CRITIQUES DE SÛRETÉ. POUR MAINTENIR LE DEGRÉ DE SÛRETÉ DE L'APPAREIL, NE REMPLACER LES COMPOSANTS DONT LE FONCTIONNEMENT EST CRITIQUE POUR LA SÛRETÉ QUE PAR DES PIÈCES RECOMMANDÉES PAR LE FABRICANT.

NOTE: UNLESS OTHERWISE SPECIFIED ALL RESISTORS IN OHMS UNLESS ALL CAPACITORS IN μF UNLESS POWER TRANSFORMER IS DIFFERENT ACCORDING TO AREA.

CS-F33R AMP SCHEMATIC DIAGRAM
No. 2-1 1620802A

CS-F33R

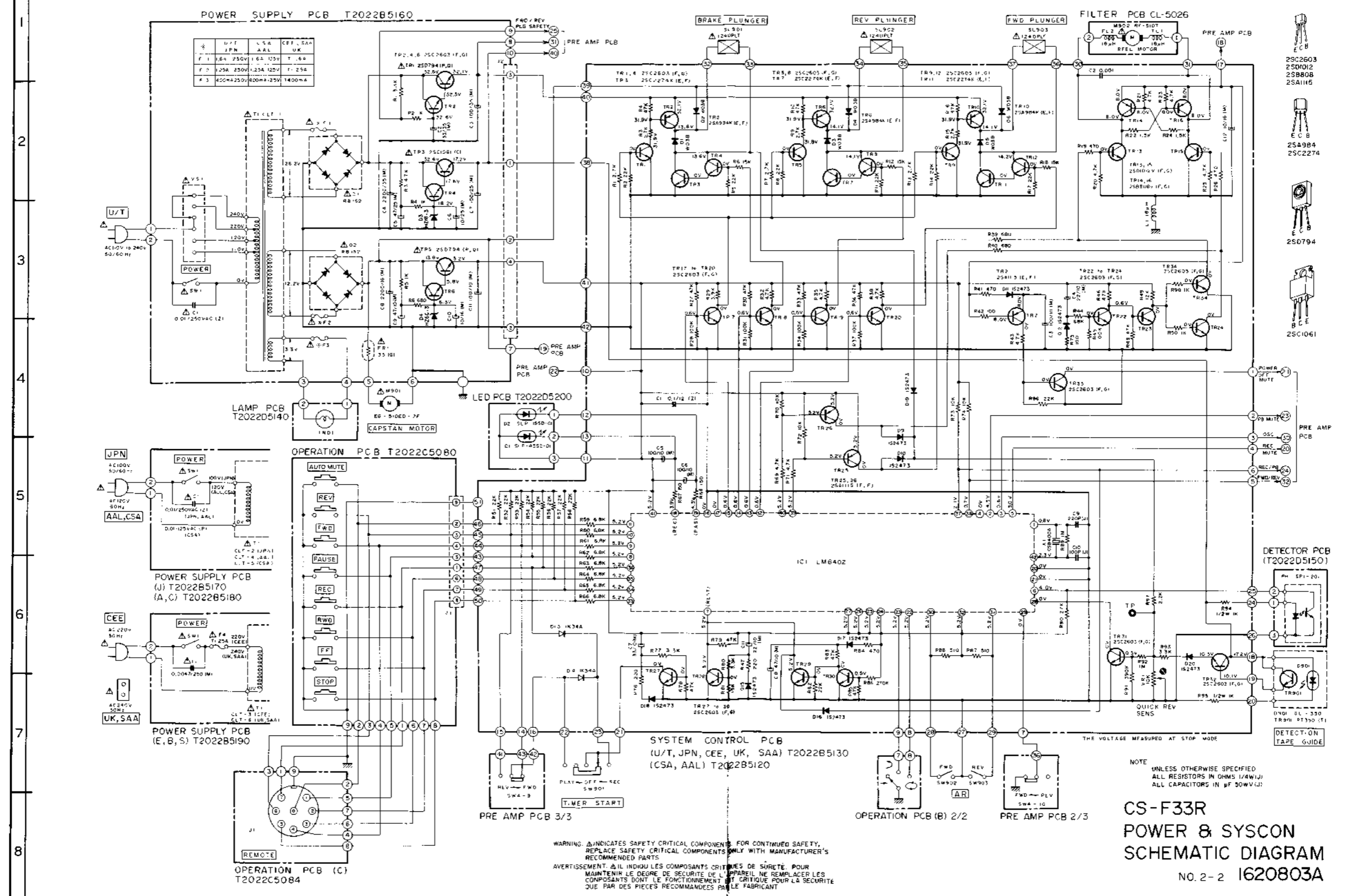

WARNING: Δ INDICATES SAFETY CRITICAL COMPONENTS. FOR CONTINUED SAFETY, REPLACE SAFETY CRITICAL COMPONENTS ONLY WITH MANUFACTURER'S RECOMMENDED PARTS.
 AVERTISSEMENT: Δ IL INDIQUE LES COMPOSANTS CRITIQUES DE SÛRETÉ. POUR MAINTENIR LE DEGRÉ DE SÛRETÉ DE L'APPAREIL, NE REMPLACER LES COMPOSANTS DONT LE FONCTIONNEMENT EST CRITIQUE POUR LA SÛRETÉ QUE PAR DES PIÈCES RECOMMANDÉES PAR LE FABRICANT.

NOTE: UNLESS OTHERWISE SPECIFIED, ALL RESISTORS IN OHMS (1/4W/1/2), ALL CAPACITORS IN μF (50WV/50V).
CS-F33R
POWER & SYSCON
SCHEMATIC DIAGRAM
 NO.2-2 1620803A

MODEL **CS-F33R**

DATE February 1981

I. TECHNICAL DATA

Track System	4 Track 2 Channel Stereo System
Tape	Philips Type Cassette
Tape Speed	4.76 cm/s \pm 1.0% (1-7/8 ips. \pm 1.0%)
Heads	Erase head x 2 High Density Metallic head for recording/playback x 1
Motors	Electronically speed controlled DC motor for capstan drive x 1 DC motor for reel drive x 1
Wow & Flutter	Less than 0.04% WRMS, 0.12% (DIN 45500)
Tape Winding Time	80 sec. using a C-60 cassette tape
Frequency Response	Normal: 30 to 16,000 Hz \pm 3 dB CrO ₂ : 30 to 16,500 Hz \pm 3 dB (-20 VU) 30 to 8,500 Hz \pm 3 dB (0 VU) Metal: 30 to 18,000 Hz \pm 3 dB (-20 VU) 30 to 12,500 Hz \pm 3 dB (0 VU)
Signal to Noise Ratio	Normal: Better than 58 dB CrO ₂ : Better than 60 dB Metal: Better than 60 dB (measured via tape with peak recording level) Dolby NR switch ON: Improves up to 10 dB above 5 kHz
Harmonic Distortion	Normal: Less than 0.8% CrO ₂ : Less than 0.7% Metal: Less than 0.7%
Input	MIC: 0.25 mV (input impedance 5.0 kohms) Required microphone impedance: 600 ohms Line: 70 mV (input impedance 47 kohms)
Output	Line: 410 mV at 0 VU Required load impedance: more than 20 kohms Phone: 50 mV/8 ohms at 0 VU
DIN	Input: 2 mV (Input impedance 10 kohms) Output: 410 mV Required load impedance: more than 20 kohms
Power Requirements	100V, 50/60 Hz for Japan 120V, 60 Hz for USA and Canada 220V, 50 Hz for Europe except UK 240V, 50 Hz for UK and Australia 110V/120V/220V/240V, 50/60 Hz internally switchable for other countries
Power Consumption	U/T, JPN, AAL, CAS 20W
Dimensions	440(W) x 118(H) x 270(D) mm (17.3 x 4.6 x 10.6")
Weight	7.5 kg (16.5 lbs)

* For improvement purposes, specifications and design are subject to change without notice.

* "Dolby" and the Double D symbol are trademarks of Dolby Laboratories.
(Manufactured under license from Dolby Laboratories).

AKAI ELECTRIC CO., LTD.12-14, 2-chome, Higashi-Kojiya, Ohta-ku, Tokyo, Japan.
Printed in Japan.

II. VOLTAGE AND CYCLE CONVERSION

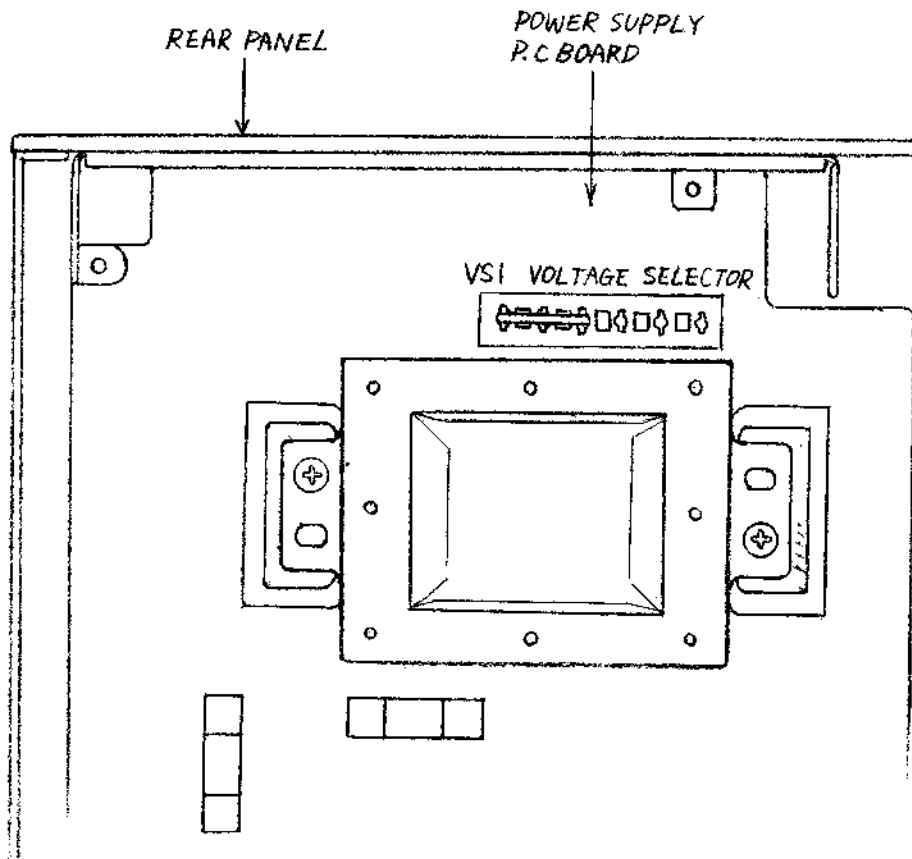

Fig. 2-1 Voltage Conversion (U/T Model Only)

1. VOLTAGE CONVERSION

Models for Canada, Europe, USA, UK, Australia and Japan are not equipped with this facility.

Each machine is preset at the factory according to destination, but some machines can be set to 110V, 120V, 220V or 240V as required.

If voltage change is necessary, this can be accomplished as follows:

- 1) Disconnect power cord.
- 2) Loosen holding screws and remove upper cover.
- 3) Remove short pin plug from present holes and replace in correct holes.

Follow the markings explicitly.

2. CYCLE CONVERSION

With DC motor, cycle conversion is not necessary.

III. MECHANICAL ADJUSTMENT

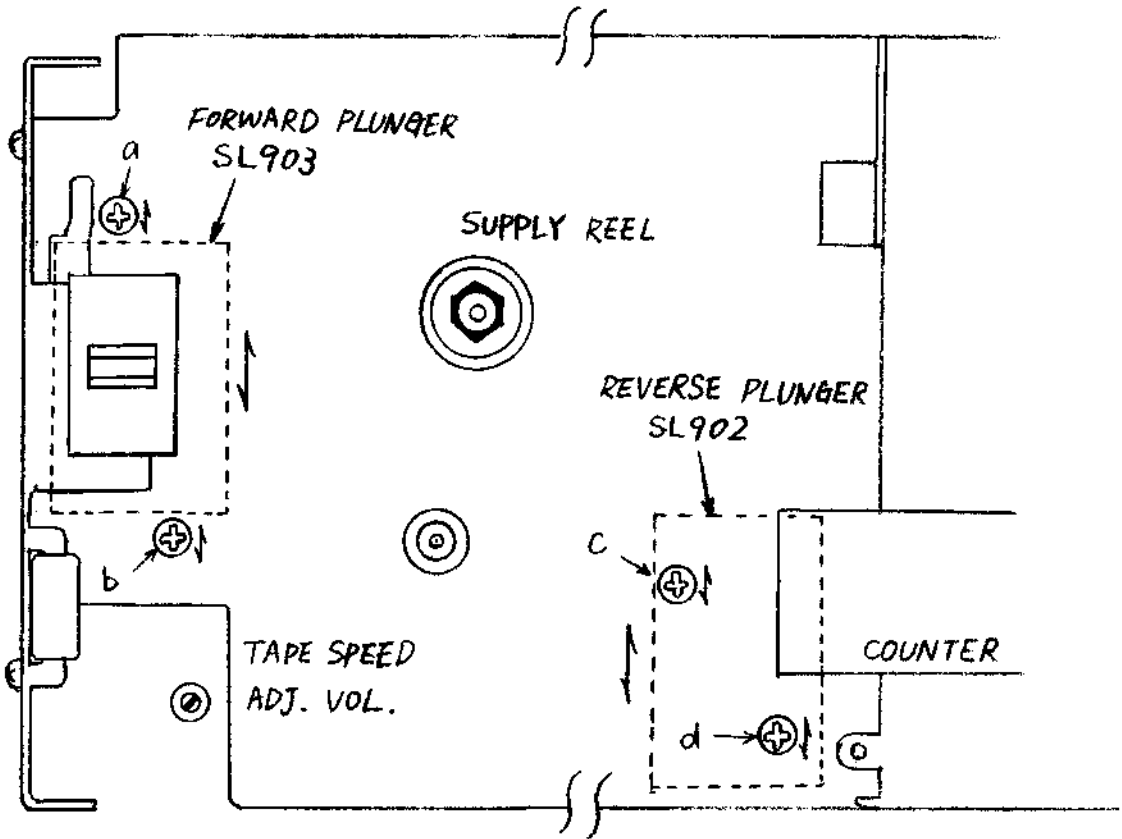

Fig. 3-1

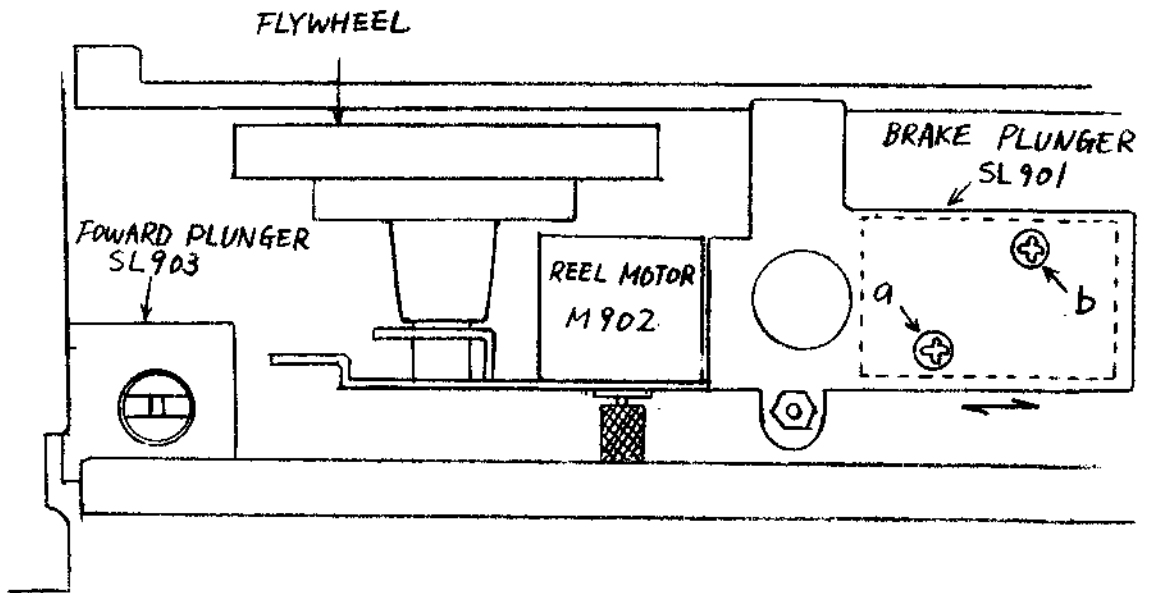

Fig. 3-2

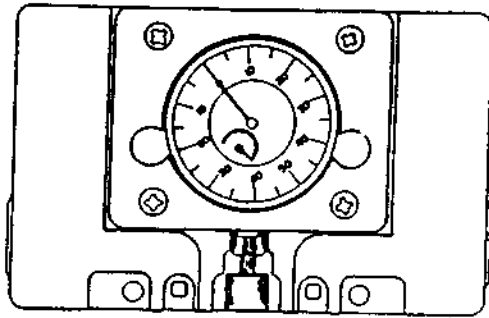

Fig. 3-3 AKAI Head Projection Gauge

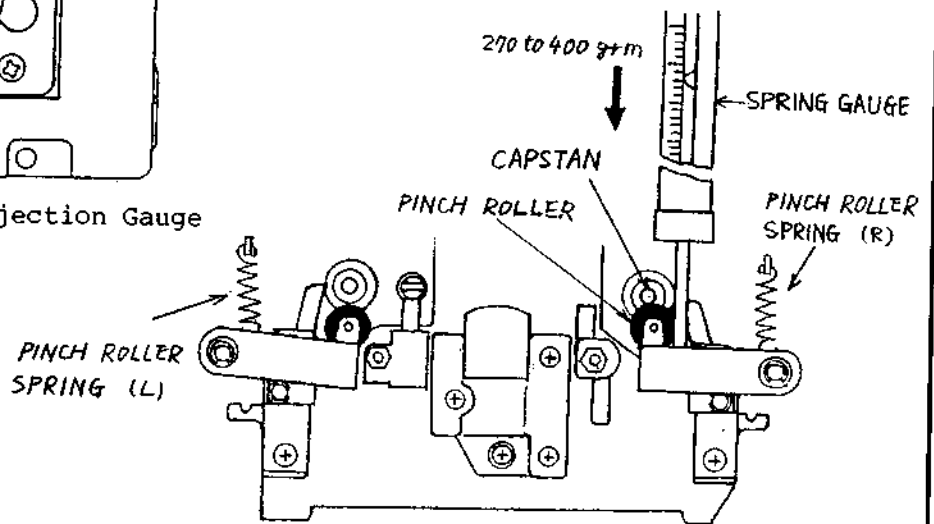

Fig. 3-4

1. PLUNGER POSITION ADJUSTMENT

1) Forward Plunger Adjustment (Refer to Figs. 3-1, 3-2)

Set the AKAI Head Projection Gauge.

Adjust the screws (a) and (b) so that when FWD PAUSE mode is engaged, the Head Projection Gauge indicates to $2.7 \text{ mm} \pm 0.1 \text{ mm}$.

2) Brake Plunger Adjustment (Refer to Figs. 3-2, 3-3)

Set the AKAI Head Projection Gauge.

Adjust the screws (a) and (b) so that when FWD PLAY mode is engaged, the Head Projection Gauge indicates to $3.35 \text{ mm} \pm 0.1 \text{ mm}$.

3) Reverse Plunger Adjustment (Refer to Figs. 3-1, 3-3)

Set the AKAI Head Projection Gauge.

Adjust the screws (c) and (d) so that when REV PAUSE mode is engaged, the Head Projection Gauge indicates to $2.5 \text{ mm} \pm 0.1 \text{ mm}$.

NOTE: This adjustment made is order of numbers.

2. PINCH ROLLER PRESSURE MEASUREMENT (Refer to Fig. 3-4)

Put in FWD PLAY mode. Push pinch roller arm down with the spring gauge push the pinch roller 1 - 2 mm from the capstan and release slowly.

Read the spring gauge at the moment the pinch roller touches the capstan and begins to rotate.

Specified contact pressure measurement of 270 of 400 gm.

If there is no measurement obtained, replace the pinch roller spring.

Do the same for the reverse side.

3. WINDING TORQUE MEASUREMENT IN EACH MODE

Insert cassette torque meter and measure in each mode.

For fast forward and rewind measure at the end of the tape when the tape has stopped running.

Forward, Reverse : 30 to 55 g-cm

Fast Forward, Rewind : 75 to 130 g-cm

4. TAPE SPEED ADJUSTMENT (Refer to Fig. 3-1)

Connect a frequency counter to line output terminals.

Playback a 1,000 Hz pre-recorded test tape and adjust tape speed adjustment volume to obtain a tape speed of 995 Hz \pm 5 Hz.

IV. HEAD ADJUSTMENT

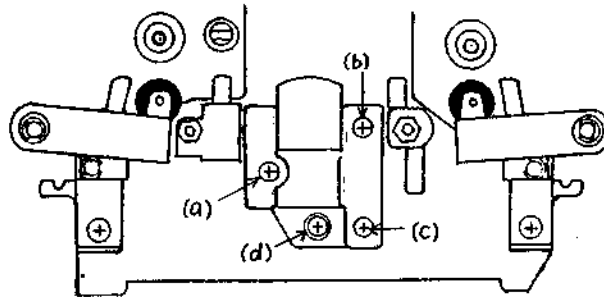

Fig. 4-1

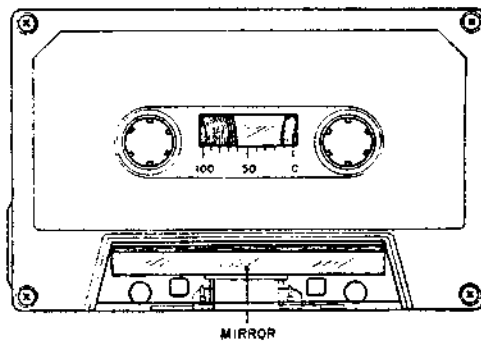

Fig. 4-2

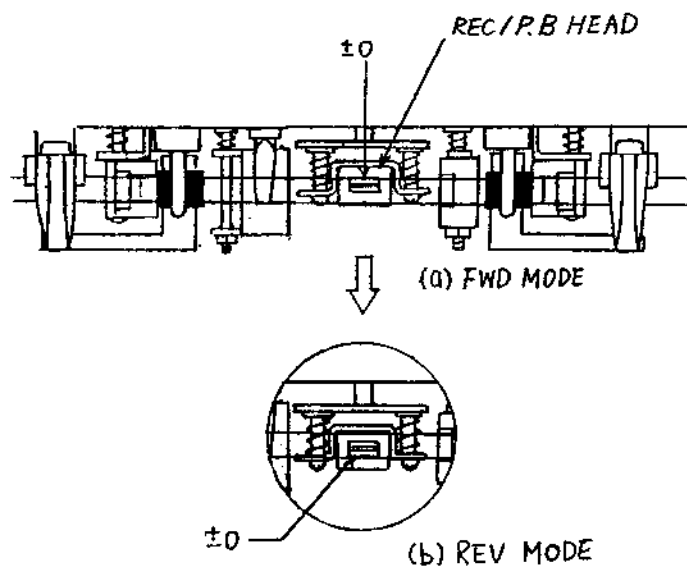

Fig. 4-3

1. REC/PB HEAD HEIGHT ADJUSTMENT (Refer to Figs. 4-1 to 4-3)
Playback the Head Height Adjustment Tape (4 Track 1,000 Hz) in the Reverse Play Mode and adjust the screws (a) (b) and (c) until the output level of both channels reaches maximum.
Next put in the Forward Mode and adjust the screw (d) so that output level reaches maximum same as above.
2. REC/PB HEAD AZIMUTH ADJUSTMENT (Refer to Fig. 4-1)
 - 1) Playback the azimuth adjustment tape (10 kHz) in the REV PLAY mode and adjust screw (a), (b), (c) until the output level of both channels reaches maximum (the AC voltmeter registers maximum).
 - 2) Put in reverse mode and check that the output level is the same as in the forward mode. If different, adjust with screw (a), (b), (c) until the level is the same in both modes.
 - 3) After adjustment, check both the head height and the azimuth.

- NOTES:
1. Be sure to clean the heads prior to head adjustment.
 2. Be careful not to use a magnetized driver or other magnetized tools in the vicinity of the heads.
 3. Be sure to demagnetize the heads with a Head Demagnetizer before and after head adjustment.

V. ELECTRICAL ADJUSTMENT

1. QUICK REVERSE SENSITIVITY ADJUSTMENT

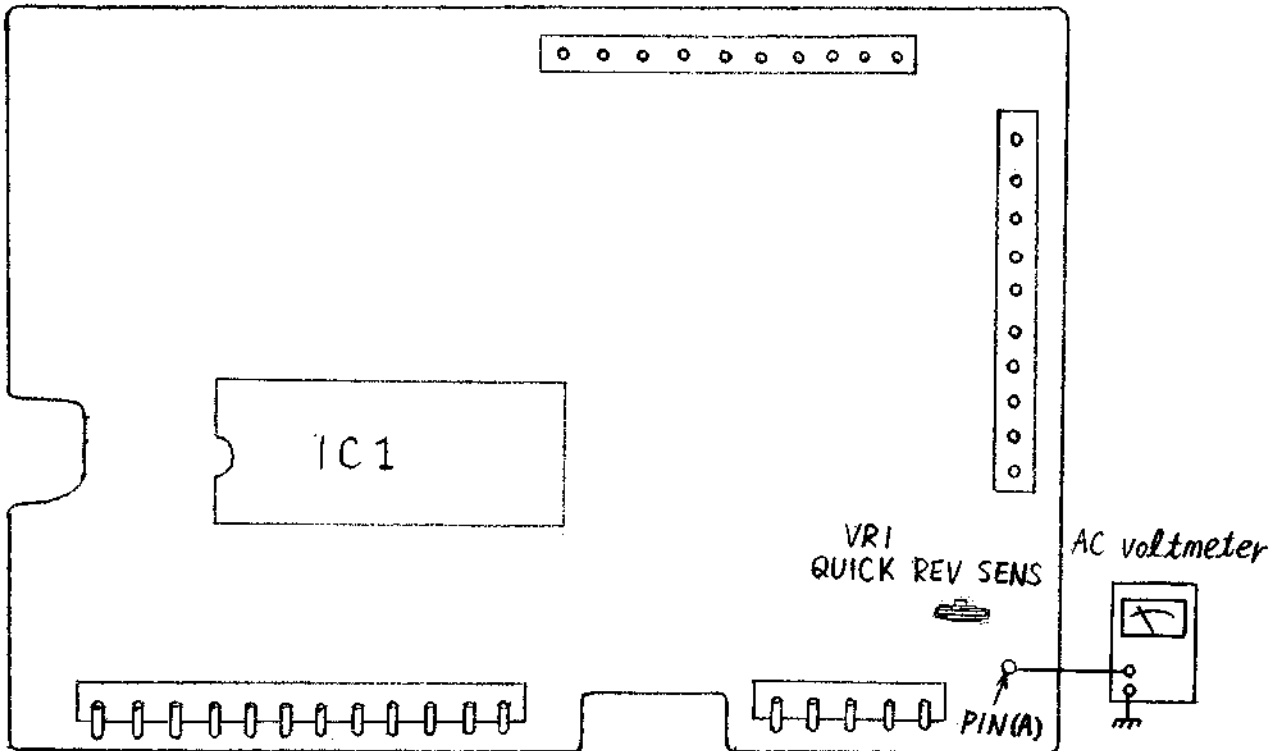

Fig. 5-1 Syscon P.C Board

- 1) Make a tapeless cassette pack by removing the tape from the white colored test tape.
- 2) Connect the AC Voltmeter between the PIN (A) and earth.
- 3) Using the tapeless cassette pack, adjust VR-1 so that the AC Voltmeter indicates $10V \pm 0.5V$ at REV play mode.

NOTE: Use only a clean tapeless cassette pack.

2. AMPLIFIER ADJUSTMENT

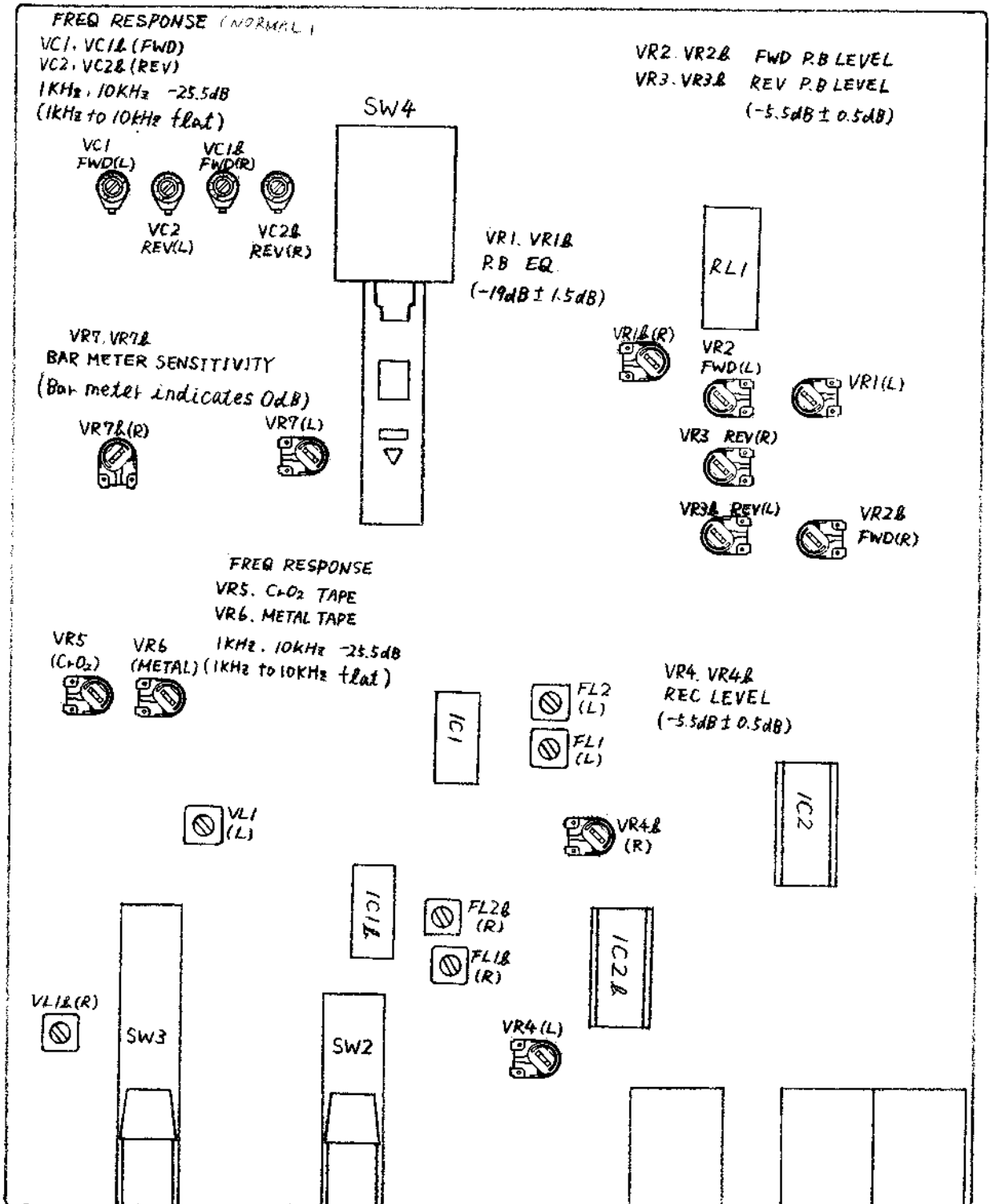

Fig. 5-2 Pre Amp P.C Board T2022A5100

VI. DC RESISTANCE OF VARIOUS COILS

DESCRIPTION	NAME	DC RESISTANCE
REC/PB Head	RP-5402-(AO)-0110	300 ohms \pm 20%
Erase Head	HF213131	3.2 ohms
Plunger Solenoid	1240PLT	90 ohms \pm 10%

VII. CLASSIFICATION OF VARIOUS P.C BOARDS

P.C BOARD TITLE	P.C BOARD NUMBER	REMARKS
Pre Amp P.C Board	T2022A5100	
Volume P.C Board	T2022A5101	
Syscon P.C Board	T2022B5120	CSA, AAL
Lamp P.C Board	T2022D5140	
Detector P.C Board	T2022D5150	
Power Supply P.C Board	T2022B5160	U/T
Power Supply P.C Board	T2022B5170	JPN
Power Supply P.C Board	T2022B5180	CSA, AAL
Power Supply P.C Board	T2022B5190	CEE, UK, SAA
LED P.C Board	T2022B5200	
Operation P.C Board	T2022C5080	
Remo Con P.C Board	T2022C5084	
Syscon P.C Board	T2022B5130	U/T, JPN, CEE, UK, SAA

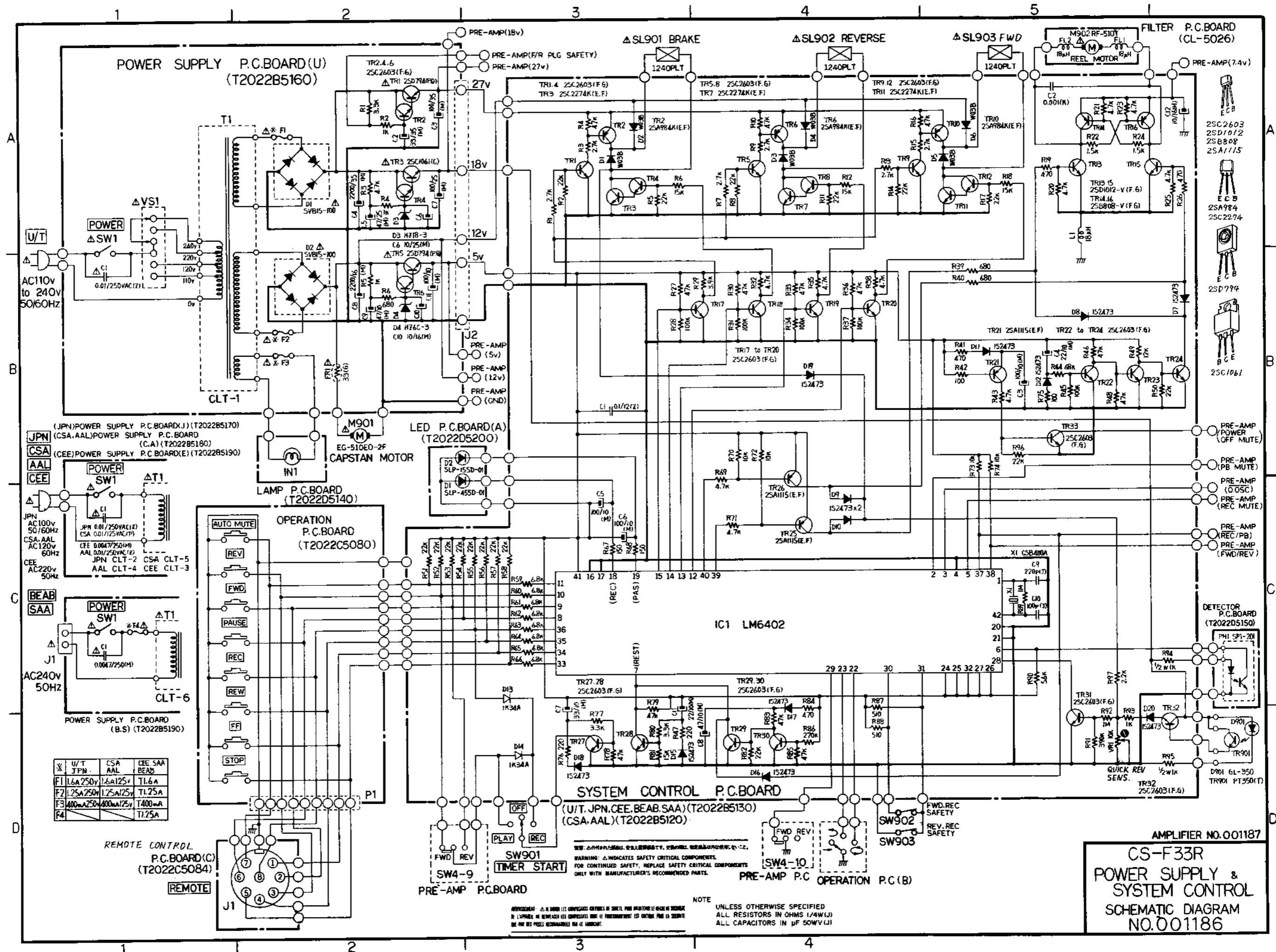

(JPN) POWER SUPPLY P.C. BOARD (J) (T2022B5170)
 (CSA.AAL) POWER SUPPLY P.C. BOARD (C.A.) (T2022B5180)
 (CEE) POWER SUPPLY P.C. BOARD (E) (T2022B5190)

JPN	AC 100V	50/60Hz
CSA.AAL	AC 120V	60Hz
CEE	AC 220V	50Hz

POWER SW1
 JPN 0.01/250VAC(1Z)
 CSA 0.01/125VAC(1P)
 CEE 0.0047/250V(M)
 AAL 0.01/250VAC(1Z)
 JPN CLT-2 CSA CLT-5
 AAL CLT-4 CEE CLT-3

(BEAB.SAA)

U/T	CSA	CEE	SAA
F1	1.6A 250V	1.6A 125V	TL6A
F2	1.25A 250V	1.25A 125V	TL25A
F3	400mA 250V	400mA 125V	T400mA
F4			TL25A

POWER SW1
 J1 AC 240V 50Hz
 0.0047/250V(M)
 CLT-6

REMOTE CONTROL P.C. BOARD (C) (T2022C5084)

7	1	2	3	4	5	6
8	9	10	11	12	13	14

REMOTE

NOTE
 UNLESS OTHERWISE SPECIFIED
 ALL RESISTORS IN OHMS (1/4W/1/2)
 ALL CAPACITORS IN pF 50WV(1)

AMPLIFIER NO.00187
 CS-F33R
 POWER SUPPLY &
 SYSTEM CONTROL
 SCHEMATIC DIAGRAM
 NO.001186

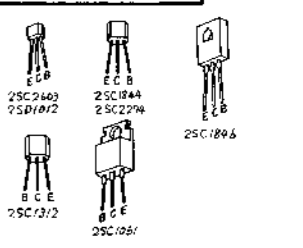
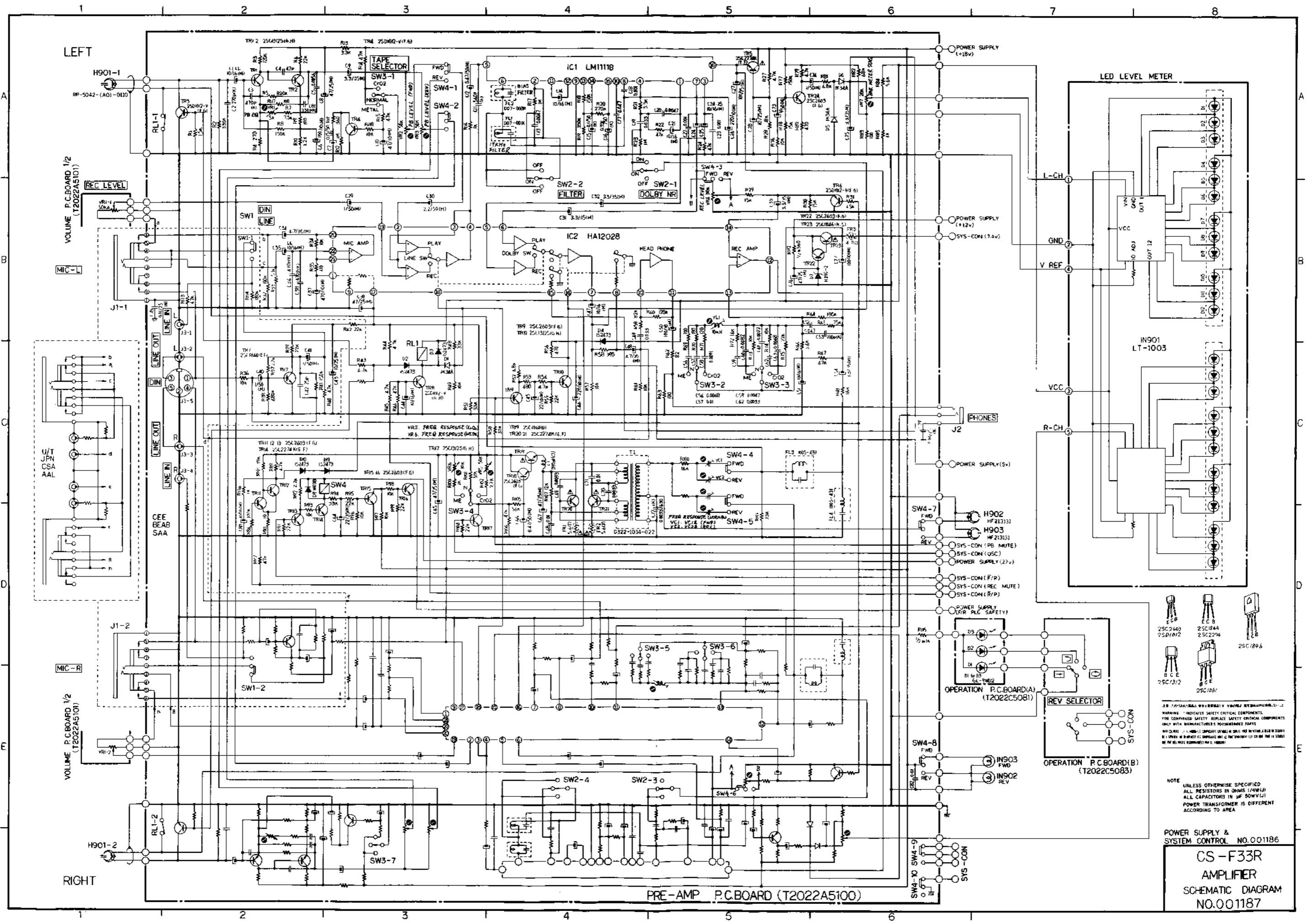

NOTE
UNLESS OTHERWISE SPECIFIED
ALL RESISTORS IN OHMS (1/4W/1%)
ALL CAPACITORS IN MF (50V/1%)
POWER TRANSFORMER IS DIFFERENT
ACCORDING TO AREA

POWER SUPPLY &
SYSTEM CONTROL NO.001186

**CS-F33R
AMPLIFIER
SCHEMATIC DIAGRAM
NO.001187**