

SERVICE MANUAL
PARTS LIST

CS-703D
MODEL GXC-704D



ALSO APPLICABLE TO BLACK PANEL MODEL



CS-703D



GXC-704D

STEREO CASSETTE DECK

CS-703D
MODEL GXC-704D

SECTION 1	SERVICE MANUAL	3
SECTION 2	PARTS LIST	39
SECTION 3	SCHEMATIC DIAGRAM	63

SECTION 1

SERVICE MANUAL

TABLE OF CONTENTS

I. TECHNICAL DATA	4
1. MODEL CS-703D	4
2. MODEL GXC-704D	5
II. DISMANTLING OF UNIT	6
III. CONTROLS	7
1. MODEL CS-703D	7
2. MODEL GXC-704D	8
IV. PRINCIPAL PARTS LOCATION	9
1. MODEL CS-703D	9
2. MODEL GXC-704D	10
V. MECHANISM ADJUSTMENT	11
1. FLYWHEEL LOOSE PLAY ADJUSTMENT	11
2. PINCH ROLLER PRESSURE MEASUREMENT	11
3. TAKE-UP TORQUE AT VARIOUS MODES	11
4. MUTE SWITCH ADJUSTMENT	12
5. MOTOR SWITCH ADJUSTMENT	12
6. TAPE SPEED ADJUSTMENT	12
IV. HEAD ADJUSTMENT	13
1. MODEL CS-703D	13
2. MODEL GXC-704D	14
VII. AMPLIFIER ADJUSTMENT	15
1. MODEL CS-703D	16
2. MODEL GXC-704D	18
VIII. DC RESISTANCE OF VARIOUS COILS	21
IX. CLASSIFICATION OF VARIOUS P.C BOARDS	21
1. P.C BOARD TITLES AND IDENTIFICATION NUMBERS	21
2. MODEL CS-703D COMPOSITION OF VARIOUS P.C BOARDS	22
3. MODEL GXC-704D COMPOSITION OF VARIOUS P.C BOARDS	28

For basic adjustments, measuring methods, and operating principles, refer to GENERAL TECHNICAL MANUAL.

I. TECHNICAL DATA

I. MODEL CS-703D

TRACK SYSTEM	4 track, 2 channel stereo system
TAPE	Philips type cassette tape
TAPE SPEED	4.76 cm/s $\pm 2\%$ (1-7/8 ips $\pm 2\%$)
WOW AND FLUTTER	Less than 0.06% WRMS, 0.16% (DIN 45500)
FREQUENCY RESPONSE	40 to 13,000 Hz ± 3 dB using LN tape 40 to 15,000 Hz ± 3 dB using CrO ₂ (SA) tape
DISTORTION (1,000 Hz "0" VU)	Less than 1.3% using LN tape Less than 2.0% using CrO ₂ (SA) tape
SIGNAL TO NOISE RATIO	Better than 54 dB using LN tape Better than 56 dB using CrO ₂ (SA) tape (measured via tape with peak recording level) Dolby NR switch ON: Improves up to 10 dB above 5 kHz
ERASE RATIO	Better than 65 dB
BIAS FREQUENCY	85 kHz
HEADS	(2): One recording/playback head, one erase head
MOTOR	(1): Electronically speed controlled DC Motor
FAST FORWARD AND REWIND TIME	120 sec using a C-60 cassette tape
OUTPUT JACKS	Line (2): 410 mV (0 VU) Required load impedance: more than 20 kohms Phone (1): 50 mV/8 ohms
INPUT JACKS	Microphone (2): 0.25 mV (Input impedance 5.0 kohms) Required microphone impedance: 600 ohms Line (2): 70 mV (Input impedance 100 kohms)
DIN JACK	Input: 0.25 mV (Input impedance 2.2 kohms) Output: 410 mV Required load impedance: more than 20 kohms
POWER REQUIREMENTS	100V, 50/60 Hz for JPN 120V, 60 Hz for U.S.A. and Canada 220V, 50 Hz for European countries except UK 240V, 50 Hz for UK and Australia 110/120/220/240V (Switchable), 50/60 Hz for the other countries
DIMENSION	380(W) x 150(H) x 266(D) mm (15.0 x 5.9 x 10.5")
WEIGHT	5.1 kg (11.2 lbs) * 6.0 kg (13.2 lbs) AAL Model only

* For improvement purposes, specifications and design are subject to change without notice.

* "Dolby" and the Double D symbol are trademarks of Dolby Laboratories.
(Manufactured under license from Dolby Laboratories).

2. MODEL GXC-704D

TRACK SYSTEM	4 track, 2 channel stereo system
TAPE	Philips type cassette
TAPE SPEED	4.76 cm/s $\pm 1\%$ (1-7/8 ips $\pm 1\%$)
WOW & FLUTTER	Less than 0.05% WRMS, 0.14% (DIN 45500)
FREQUENCY RESPONSE	35 to 14,000 Hz ± 3 dB using LN tape 35 to 14,000 Hz ± 3 dB using LH tape 35 to 15,000 Hz ± 3 dB using CrO ₂ (SA) tape 35 to 15,000 Hz ± 3 dB using FeCr tape
DISTORTION (1,000 Hz 0 VU)	Less than 1.3% using LN tape Less than 1.3% using LH tape Less than 2.0% using CrO ₂ (SA) tape Less than 2.0% using FeCr tape
SIGNAL TO NOISE RATIO	Better than 54 dB using LN tape Better than 54 dB using LH tape Better than 56 dB using CrO ₂ (SA) tape Better than 56 dB using FeCr tape (measured via tape with peak recording level) Dolby NR switch ON: Improves up to 10 dB above 5 kHz
ERASE RATIO	Better than 65 dB
BIAS FREQUENCY	85 kHz
HEADS	(2): One GX recording/playback head, one erase head
MOTOR	(1): Electronically speed controlled DC motor
FAST FORWARD AND REWIND TIME	120 sec. using a C-60 cassette tape
OUTPUT JACKS	Line: 410 mV (0 VU). Required load impedance; More than 20 kohms Phone: 100 mV/8 ohms
INPUT JACKS	Microphone: 0.25 mV (Input impedance 5.0 kohms). Required microphone impedance: 600 ohms Line: 70 mV (Input impedance 100 kohms)
DIN JACK	Input: 0.25 mV (Input impedance 2.2 kohms) Output: 410 mV. Required load impedance; More than 20 kohms
POWER REQUIREMENTS	100V, 50/60 Hz for JPN 120V/60 Hz for U.S.A. & Canada 220V/50 Hz for European Countries except UK 240V/50 Hz for UK & Australia 110/120/220/240V (Switchable), 50/60 Hz for the other countries
DIMENSIONS	380(W) \times 150(H) \times 295(D) mm, (15.0 \times 5.9 \times 11.6")
WEIGHT	5.2 kg (11.4 lbs), *6.1 kg (13.4 lbs) AAL Model only

* For improvement purposes, specifications and design are subject to change without notice.

* "Dolby" and the Double D symbol are trade marks of Dolby Laboratories.
(Manufactured under license from Dolby Laboratories).

II. DISMANTLING OF UNIT

In case of trouble, etc. necessitating dismantling, please dismantle in the order shown in the photographs. Reassemble in reverse order.

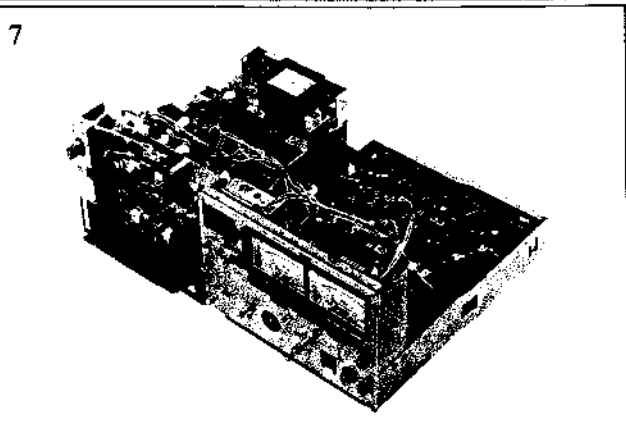
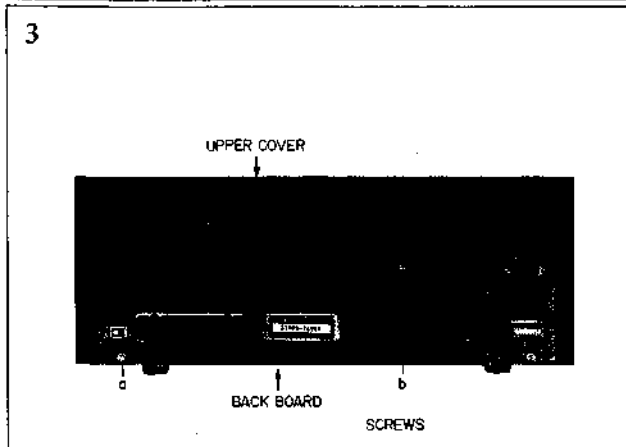
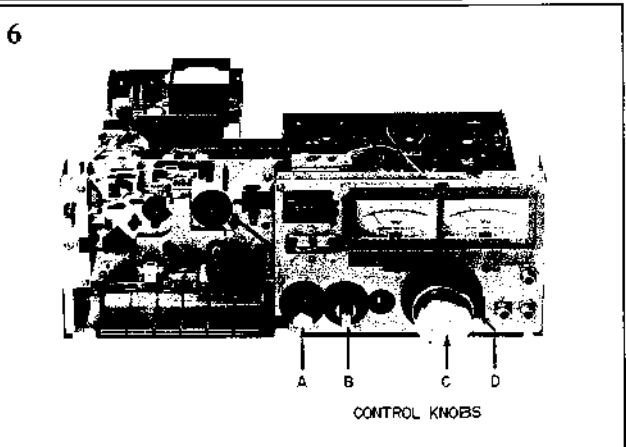
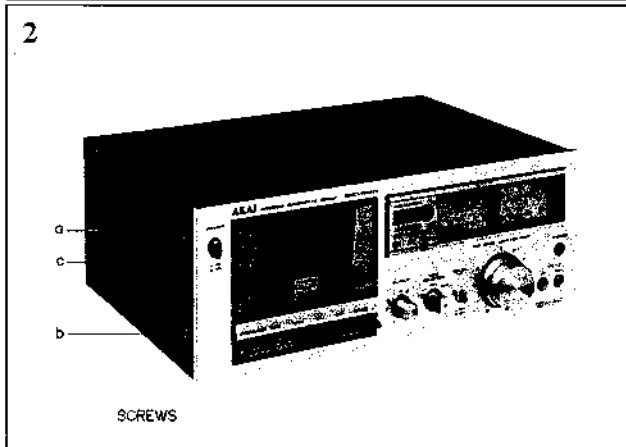
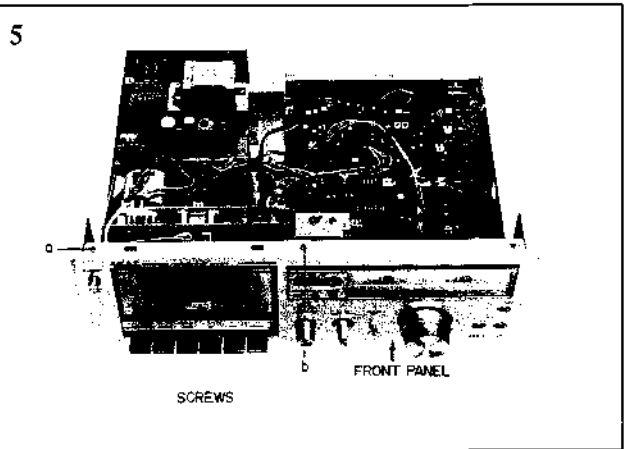
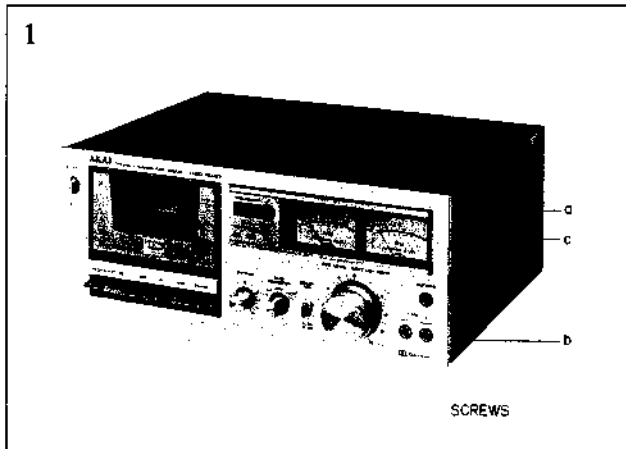
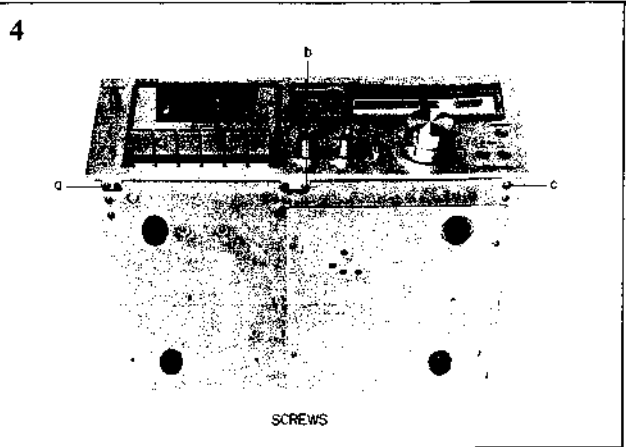

III. CONTROLS

1. MODEL CS-703D

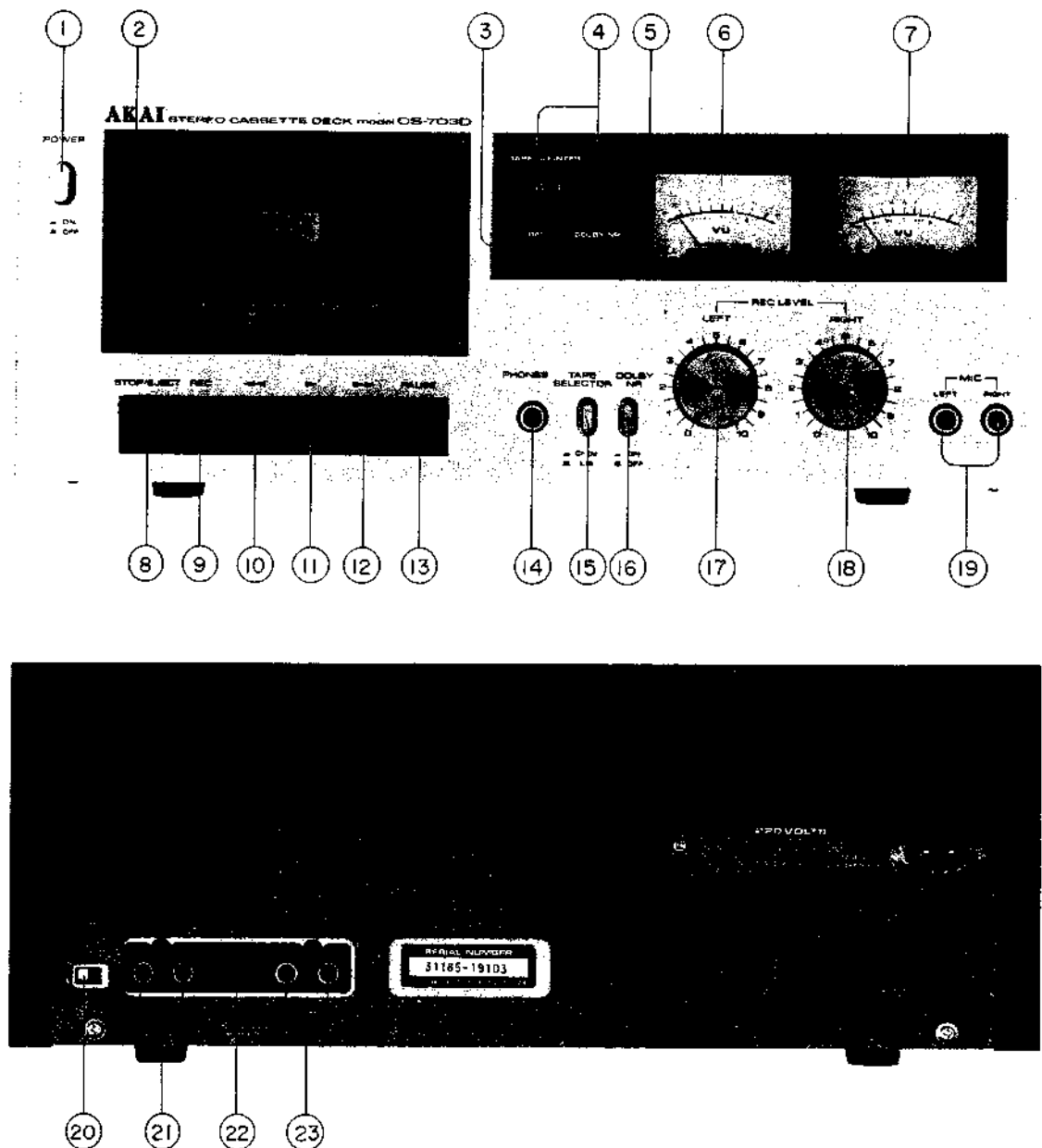

Fig. 1 Controls

- | | |
|-----------------------------------|-----------------------------------|
| 1. POWER SWITCH | 13. PAUSE KEY |
| 2. CASSETTE RECEPTACLE | 14. HEADPHONE JACK |
| 3. RECORDING INDICATOR LAMP | 15. TAPE SELECTOR |
| 4. INDEX COUNTER AND RESET BUTTON | 16. DOLBY NR SWITCH |
| 5. DOLBY NR INDICATOR LAMP | 17. LEFT RECORDING LEVEL CONTROL |
| 6. LEFT VU METER | 18. RIGHT RECORDING LEVEL CONTROL |
| 7. RIGHT VU METER | 19. MICROPHONE JACKS |
| 8. STOP/EJECT KEY | 20. *LINE/DIN INPUT SELECTOR |
| 9. RECORDING (REC) KEY | 21. LINE INPUT JACKS |
| 10. REWIND (◀) KEY | 22. *DIN JACK |
| 11. PLAY (▶) KEY | 23. LINE OUTPUT JACKS |
| 12. FAST FORWARD (▶▶) KEY | |

* JPN and AAL models are not equipped with this facility

2. MODEL GXC-704D

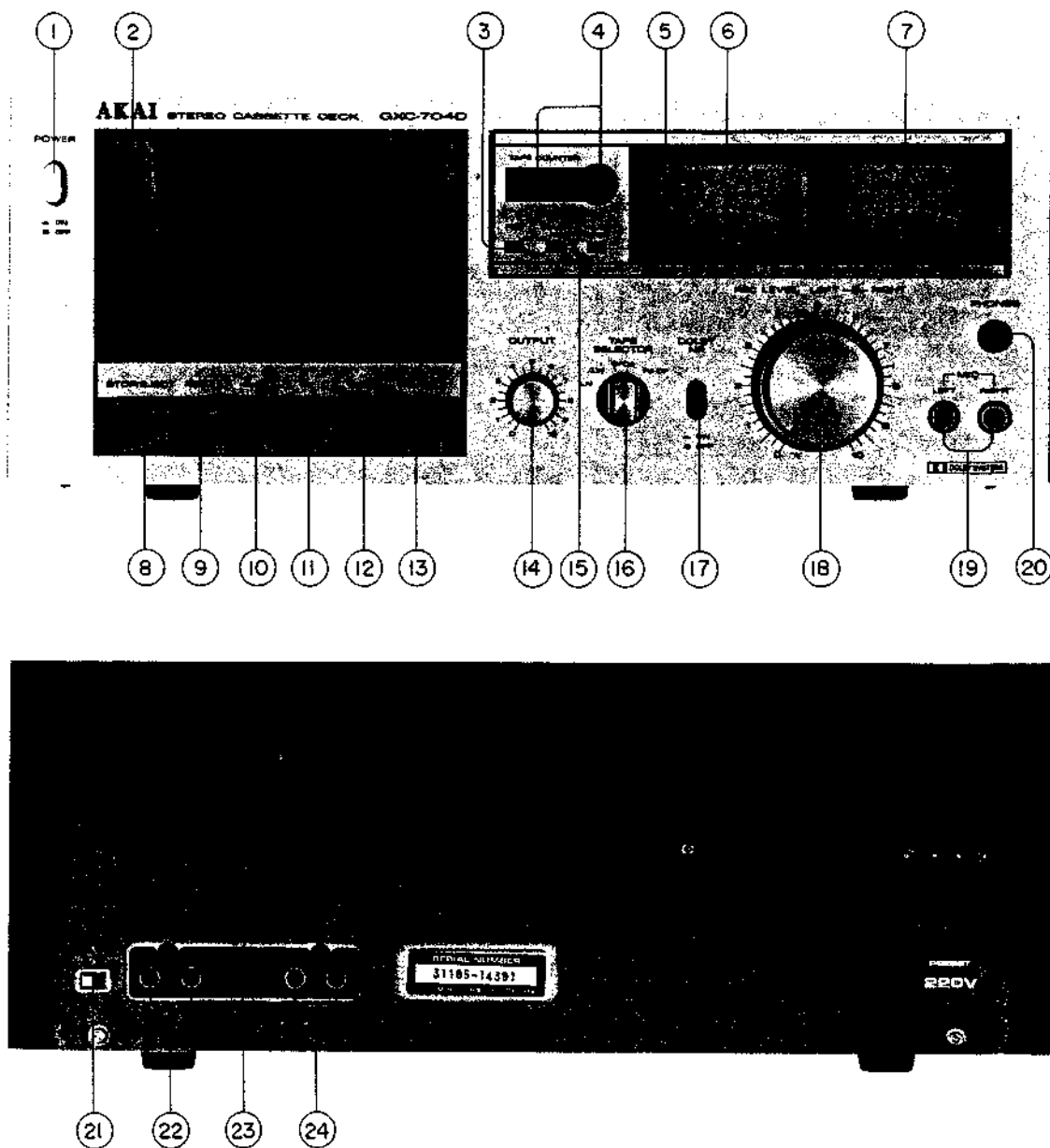

Fig. 2 Controls

- | | |
|-----------------------------------|---|
| 1. POWER SWITCH | 13. PAUSE KEY |
| 2. CASSETTE RECEPTACLE | 14. OUTPUT LEVEL CONTROL |
| 3. RECORDING INDICATOR LAMP | 15. DOLBY NR INDICATOR LAMP |
| 4. INDEX COUNTER AND RESET BUTTON | 16. TAPE SELECTOR SWITCH |
| 5. PEAK LEVEL INDICATOR | 17. DOLBY NR SWITCH |
| 6. LEFT VU METER | 18. LEFT → RIGHT RECORDING LEVEL CONTROLS |
| 7. RIGHT VU METER | 19. MICROPHONE JACKS |
| 8. STOP/EJECT KEY | 20. HEADPHONE JACK |
| 9. RECORDING (REC) KEY | 21. *INPUT SELECTOR SWITCH |
| 10. REWIND (◀) KEY | 22. LINE INPUT JACKS |
| 11. PLAY (▶) KEY | 23. *DIN JACK |
| 12. FAST FORWARD (▶▶) KEY | 24. LINE OUTPUT JACKS |

* JPN and AAL models are not equipped with this facility

IV. PRINCIPAL PARTS LOCATION

1. MODEL CS-703D

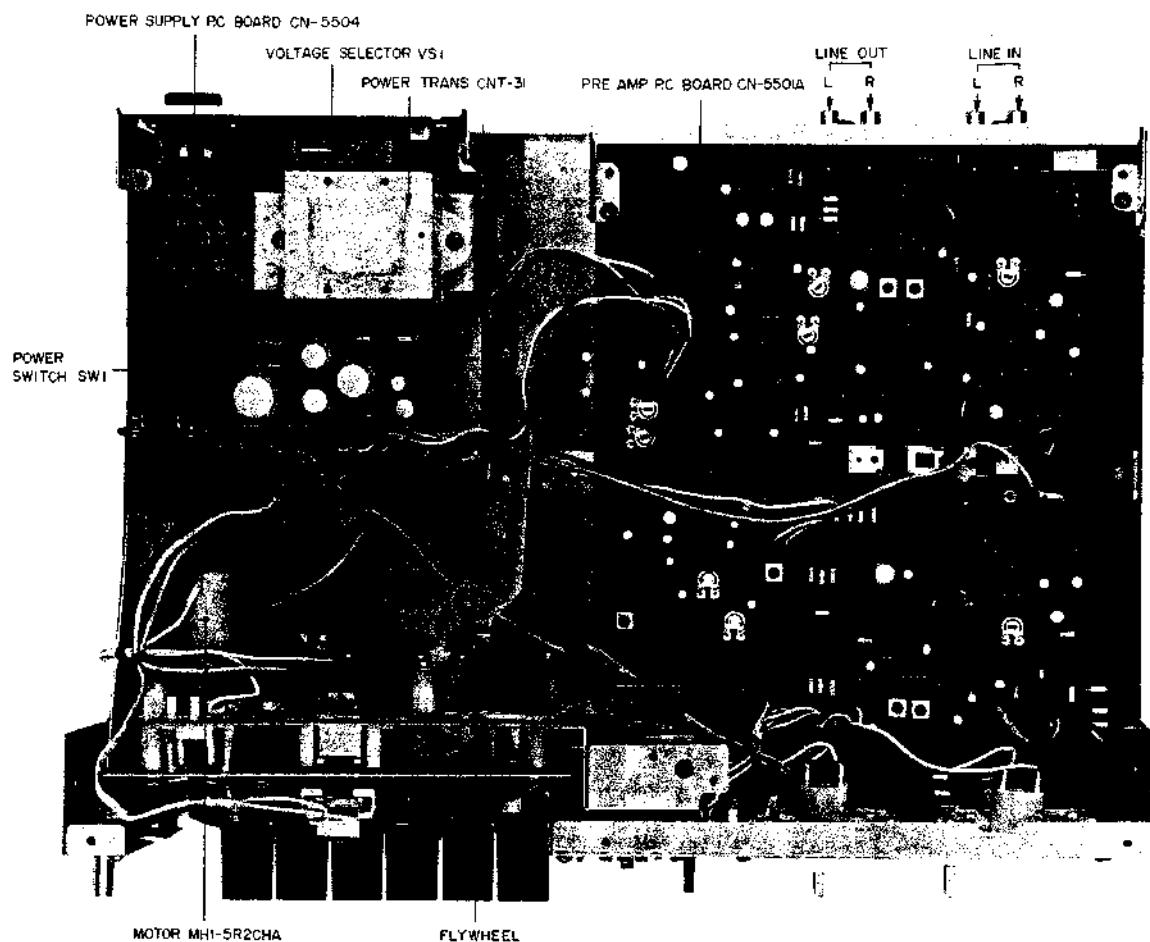

Fig. 3 Top View

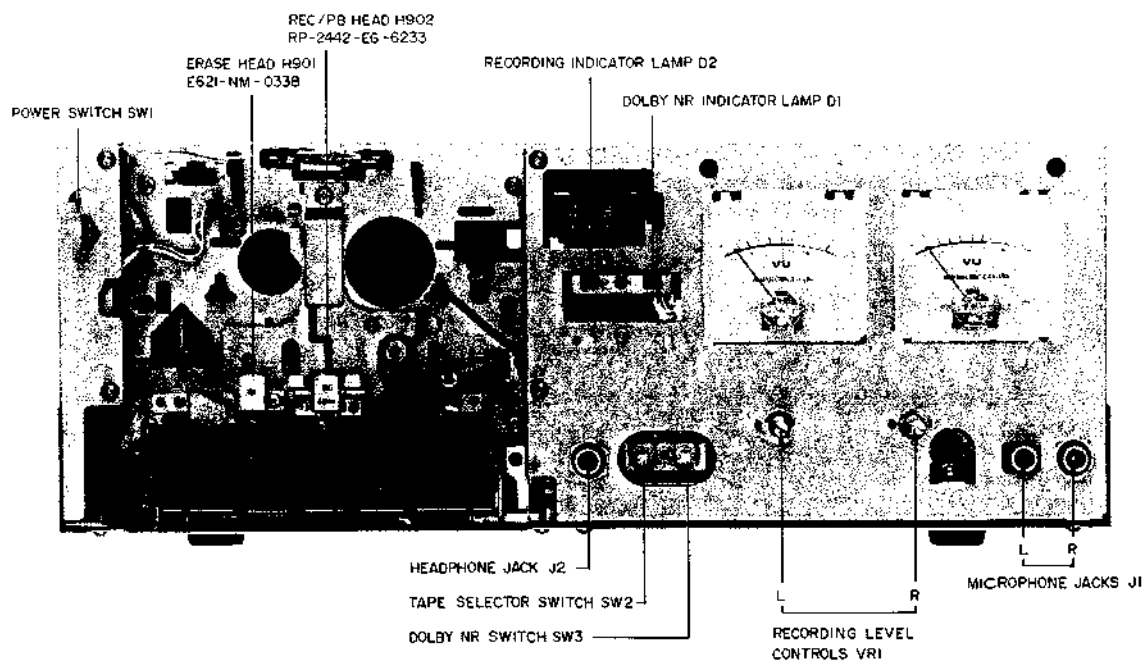

Fig. 4 Front View

2. MODEL GXC-704D

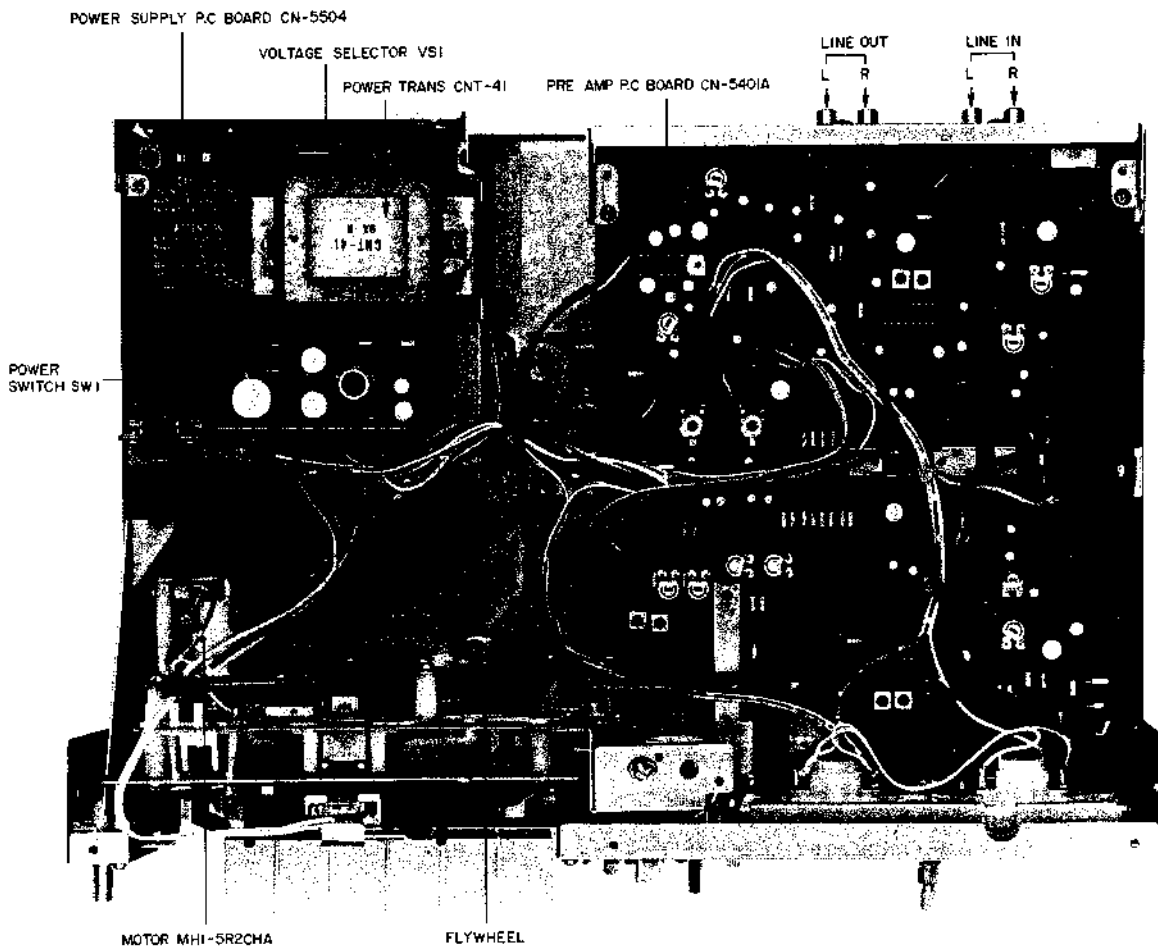

Fig. 5 Top View

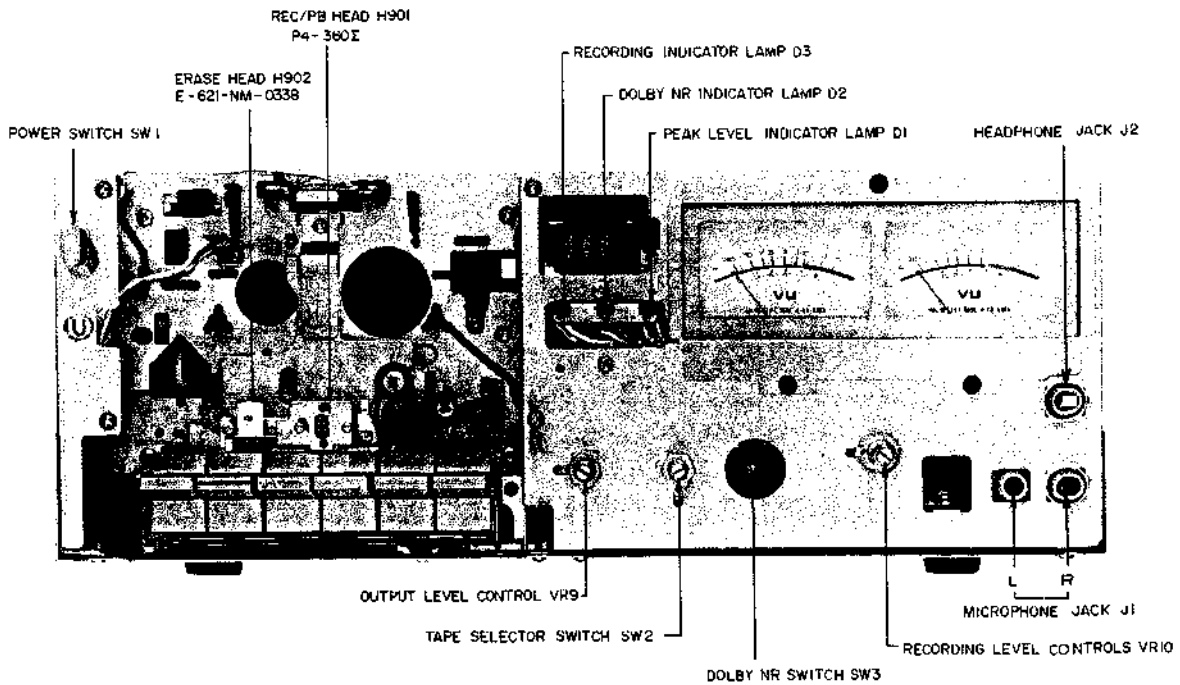

Fig. 6 Front View

V. MECHANISM ADJUSTMENT

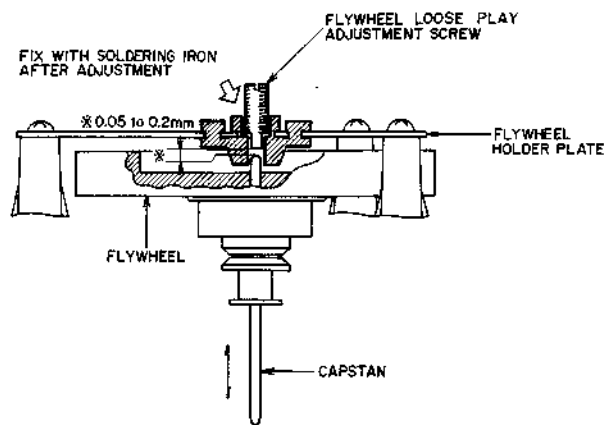

Fig. 7 Flywheel Loose Play Adjustment

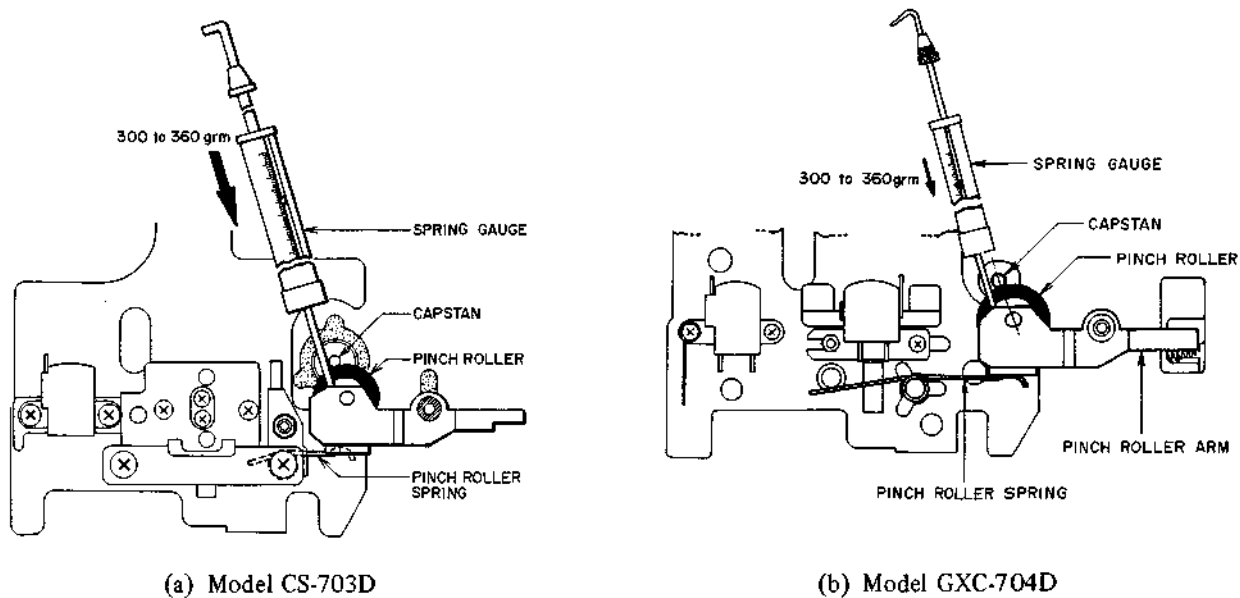

Fig. 8 Pinch Roller Pressure Measurement

1. FLYWHEEL LOOSE PLAY ADJUSTMENT (Refer to Fig. 7)

Adjust by turning flywheel loose play adjustment screw to obtain a 0.05 to 0.2 mm of loose play when the flywheel is moved as indicated by the arrow mark.

2. PINCH ROLLER PRESSURE MEASUREMENT (Refer to Fig. 8)

At playback mode, push the pinch roller with a spring gauge until the pinch roller separates from the capstan by about 1 to 2 mm and then gently return.

Take a reading of the spring gauge indication at the moment the pinch roller touches the capstan and begins to rotate.

Specified Pinch Roller Pressure: 300 to 360 gm

In case specified pressure cannot be attained, replace the pinch roller spring.

3. TAKE-UP TORQUE AT VARIOUS MODES

Playback mode : 35 to 55 gm-cm

Fast Forward mode : 70 to 120 gm-cm

Rewind mode : 70 to 120 gm-cm

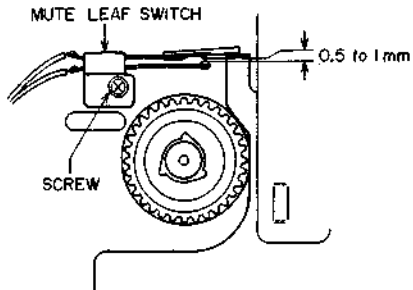

Fig. 9 Mute Switch Adjustment

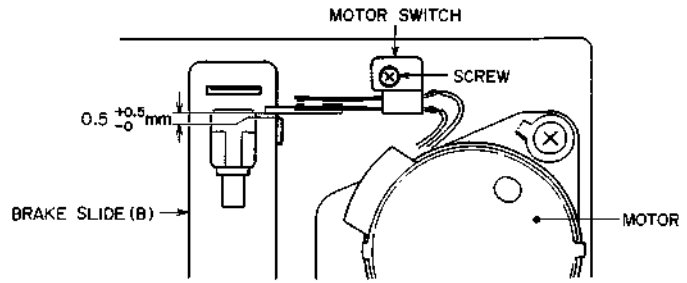
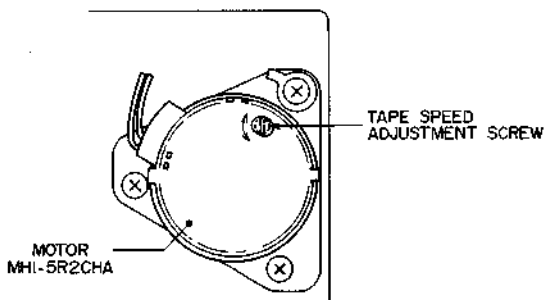
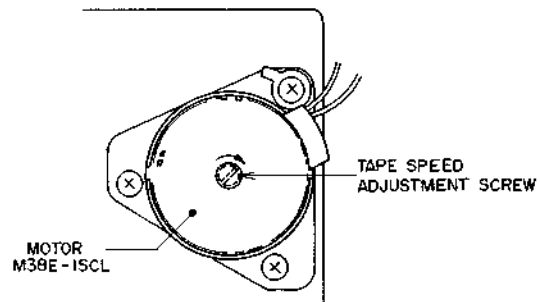

Fig. 10 Motor Switch Adjustment



(a) Except JPN Model



(b) JPN Model

Fig. 11 Tape Speed Adjustment

4. MUTE SWITCH ADJUSTMENT

(Refer to Fig. 9)

When in the playback mode, the space should be 0.5 to 1 mm as in Fig. 9. To adjust, turn the leaf switch screw.

5. MOTOR SWITCH ADJUSTMENT

(Refer to Fig. 10)

When in the Stop position, the space between the upper part of the Brake Slide switch and the lower part of the Motor leaf switch should be $0.5 +0.5/-0$ mm.

To adjust, loosen the leaf switch screw and move the leaf switch.

6. TAPE SPEED ADJUSTMENT

Connect the Frequency Counter to the line output terminals. Playback a 1,000 Hz pre-recorded test tape and adjust tape speed adjustment screw to obtain a tape speed of 1,000 Hz $\pm 1\%$.
(CS-703D: 1,000 Hz $\pm 2\%$)

IV. HEAD ADJUSTMENT

1. MODEL CS-703D

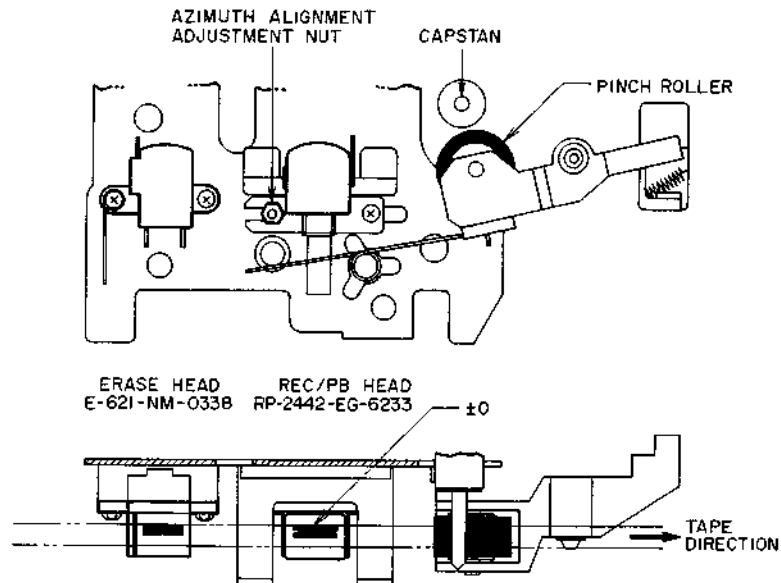

Fig. 12 Head Adjustment (CS-703D)

1) Recording/Playback Head Azimuth Alignment

(Refer to Fig. 12)

- a) Playback a 10 kHz pre-recorded cassette azimuth alignment test tape and adjust nut shown in Fig. 12 to obtain maximum output on both channels.
- b) Invert cassette and confirm that the output level does not change from that obtained in Item 1)-a above. If the output level differs, adjust in the same way as in Item 1)-a above until both sides of the test tape display equal output.

NOTES:

1. Be sure to clean the heads prior to head adjustment.
2. Be careful not to use a magnetized driver or other magnetized tools in the vicinity of the heads.
3. Be sure to demagnetize the heads with a Head Demagnetizer before and after head adjustment.

2. MODEL GXC-704D

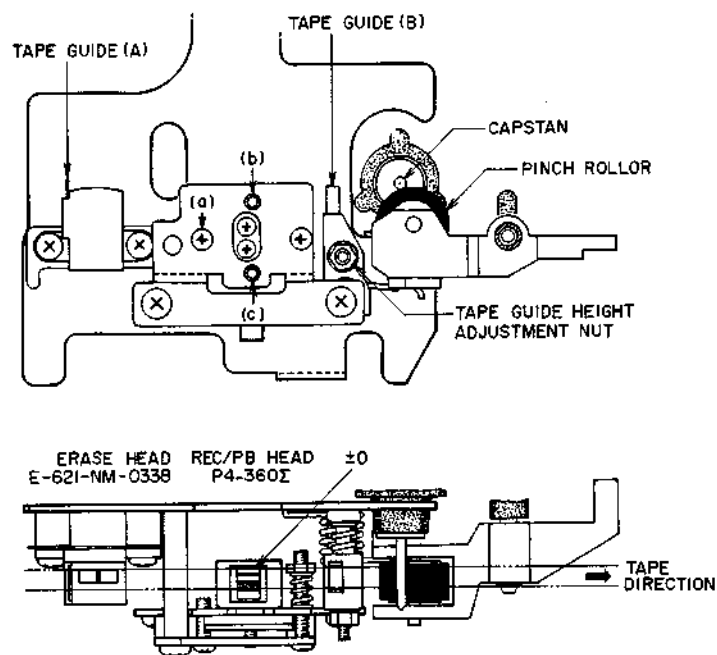

Fig. 13 Head Adjustment (GXC-704D)

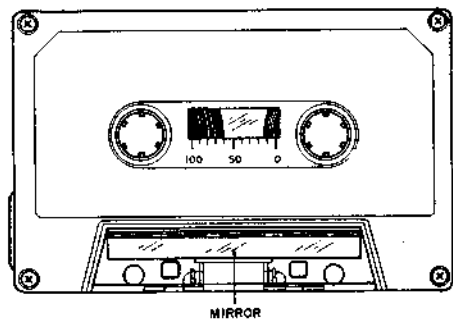

Fig. 14

1) Tape Guide Height Adjustment

(Refer to Figs. 13, 14)

- a) When using an ordinary cassette, the tape guides and heads, etc. are not visible. As shown in Fig. 14 use a cassette tape from which part of the cassette case has been cut out and a mirror installed for easy visibility of the head area when making tape guide height adjustment.
- b) At playback mode, using the Tape guide (A) shown in Fig. 13 as standard for height, adjust tape guide (B) height with tape guide height adjustment nut so that the tape runs smoothly and does not catch on the tape guides.

2) Recording/Playback Head Height Adjustment

(Refer to Figs. 13, 14)

- a) Utilize the cassette tape used in Tape Guide Height Adjustment above, and playback the leader tape part of cassette tape.
- b) As shown in Fig. 13, adjust head height with

screws (a), (b) and (c) until the upper edge of the tape is the same height as the upper edge of the left channel REC/PB head core.

- c) After completing adjustment step b), playback the Head Height Adjustment tape (4 track, 1,000 Hz) and adjust Head Height Adjustment screws (a), (b), (c) to put the output power from both channels to maximum.

3) Recording/Playback Head Azimuth Alignment Adjustment (Refer to Fig. 13)

- a) Playback a 10 kHz pre-recorded cassette azimuth alignment test tape and adjust screw (a) shown in Fig. 11 to obtain maximum output on both channels.
- b) Invert cassette and confirm that the output level does not change from that obtained in Item 3)-a above. If the output level differs, adjust in the same way as in Item 3)-a above until both sides of the test tape display equal output.
- c) After adjustment, it is better to check again head height and azimuth alignment.

NOTES:

1. Be sure to clean the heads prior to head adjustment.
2. Be careful not to use a magnetized driver or other magnetized tools in the vicinity of the heads.
3. Be sure to demagnetize the heads with a Head Demagnetizer before and after head adjustment.
4. When a mirror installed cassette test tape as shown in Fig. 14 is required, it can be ordered from AKAI Electric Co.

VII. AMPLIFIER ADJUSTMENT

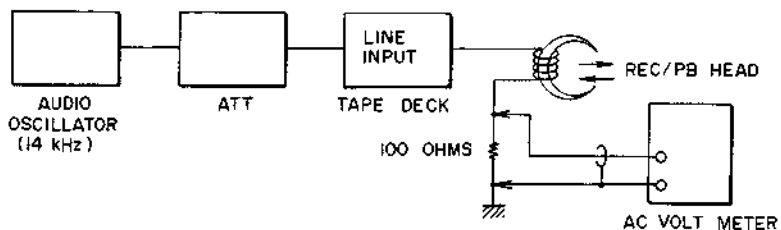
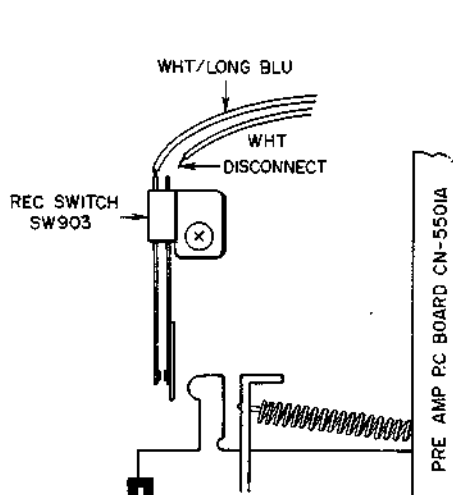
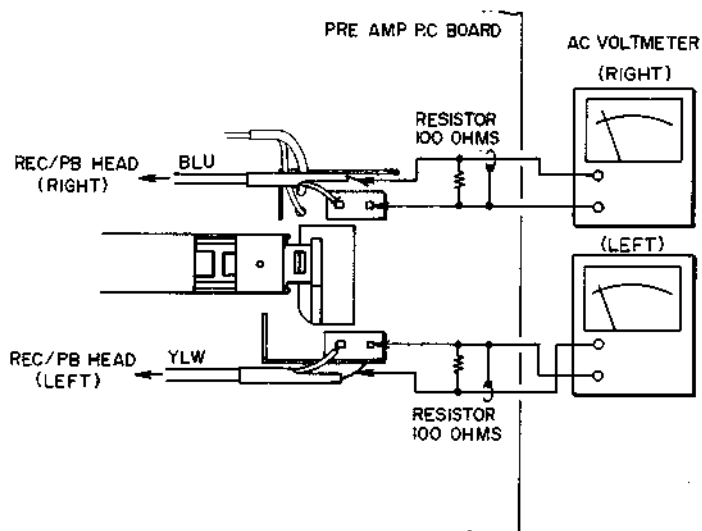
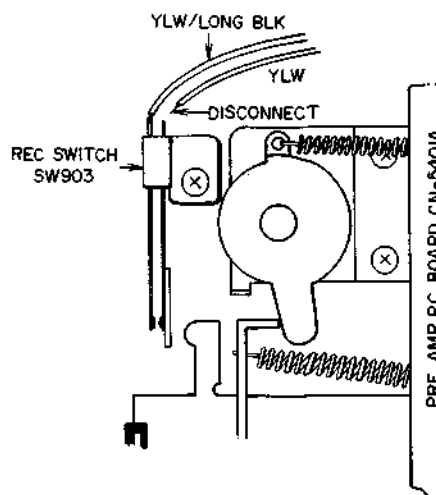

Fig. 15 Rec Peaking Adjustment Instrument Connection



(a) Model CS-703D



(b) Model GXC-704D

Fig. 16 Rec Peaking Adjustment

1. MODEL CS-703D

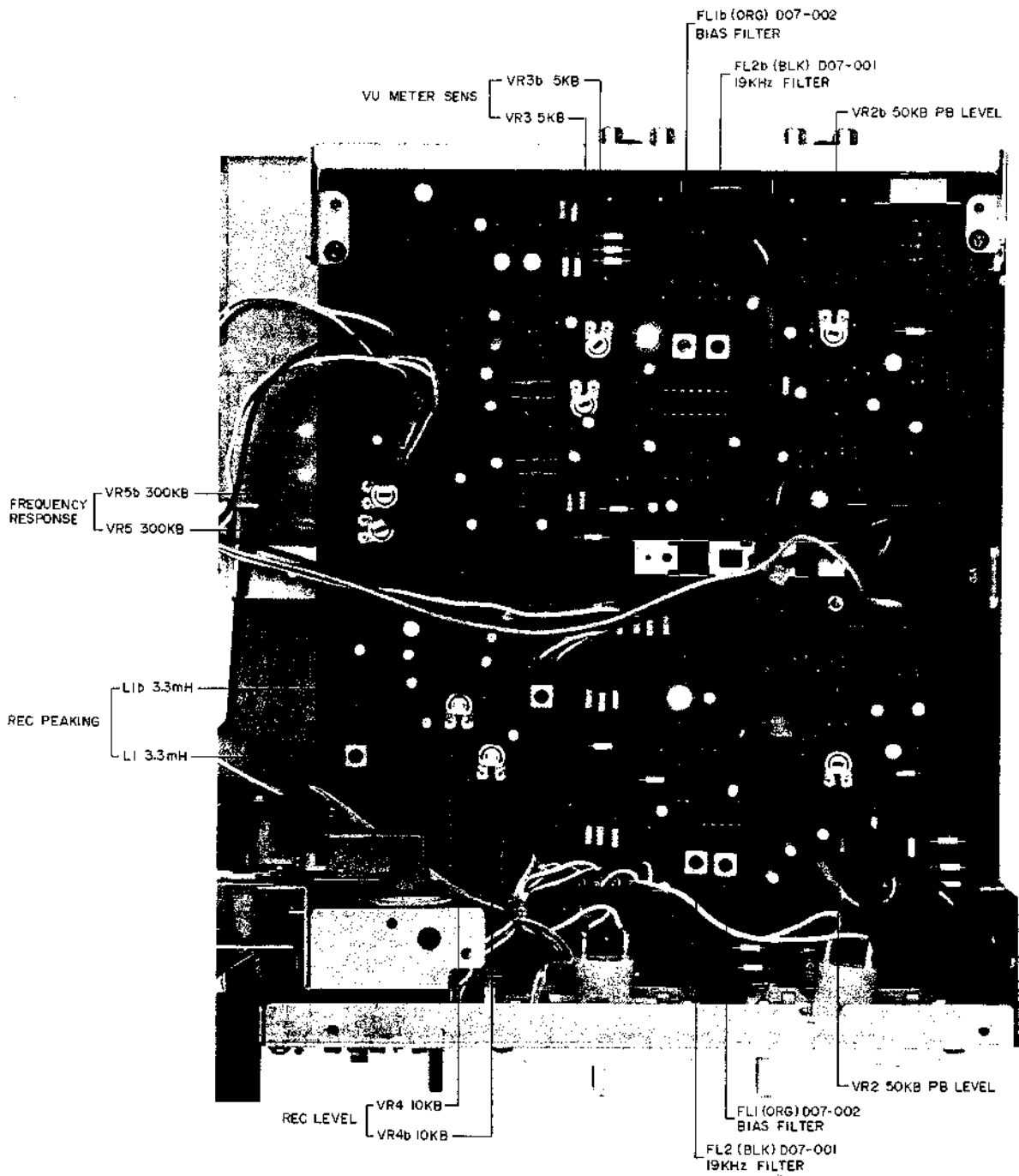

Fig. 17 Pre Amp P.C Board CN-5501A

Step	Adjustment Item	Test Tape Supply Signal	Mode	Adjustment Point	Result	Remarks
1	Playback level adjustment	333 Hz, 0 VU Test Tape	PLAY	VR2 50 kΩ	-5.5 ±0.5 dBm (410 mV)	
2	VU Meter Sensitivity adjustment	333 Hz, 0 VU Test Tape	PLAY	VR3 5 kΩ	0 VU indication	
3	Rec peaking adjustment	14 kHz from an oscillator	REC	L1 3.3 mH	Maximum AC voltmeter indication	(Refer to NOTE 5 and Figs. 15, 16)
4	LN Position frequency response adjustment	Low Noise Blank tape 1,000 Hz 10,000 Hz -25.5 dBm recording	REC/PLAY	VR5 300 kΩ	1,000 Hz to 10,000 Hz flat response	
5	CrO ₂ Position frequency response confirmation	CrO ₂ Blank tape 1,000 Hz 10,000 Hz -25.5 dBm recording	REC/PLAY		1,000 Hz to 10,000 Hz flat response	Set tape selector to CrO ₂ . (Refer to NOTE 6)
6	Recording level adjustment	Low Noise Blank tape 1,000 Hz -5.5 dBm recording	REC/PLAY	VR4 10 kΩ	-5.5 ±0.5 dBm (410 mV)	
7	Distortion Factor Confirmation	1,000 Hz -5.5 dBm recording	REC/PLAY	LN: Less than 1.3% CrO ₂ : Less than 2.0%		(Refer to NOTE 7)
8	Bias Filter adjustment	No signal input	REC	FL1 D07-002 (ORG)	Minimum AC voltmeter indication	Recording volume to maximum. (Refer to NOTE 9)
9	19 kHz filter adjustment	19 kHz from an oscillator	REC	FL2 D07-001 (BLK)	Minimum AC voltmeter indication	(Refer to NOTES 8, 9)

Chart-1

- NOTES:**
1. Because each of these adjustments are vital to perfect Dolby NR circuit operation, be sure that they are carried out with as little error as possible.
 2. Except for Steps 5 and 7 set tape selector to Low Noise position.
 3. Set Dolby NR switch to OFF position.
 4. Use the following cassette measuring tape:
LN tape: Fuji FL C-60
CrO₂ tape: TDK SA C-60
 5. Stop recording bias oscillator while making Rec Peaking Adjustment (Refer to Fig. 16).
 6. If a flat characteristic cannot be obtained from 1,000 Hz to 10,000 Hz at CrO₂ position, re-adjust at Step 4.
 7. If it does not comply with the specifications, repeat Steps 4 to 6 and re-adjust.
 8. Adjust the oscillators frequency to give a frequency counter reading of 19.00 kHz.
 9. Unless the core is moved intentionally this adjustment is not necessary.

2. MODEL GXC-704D

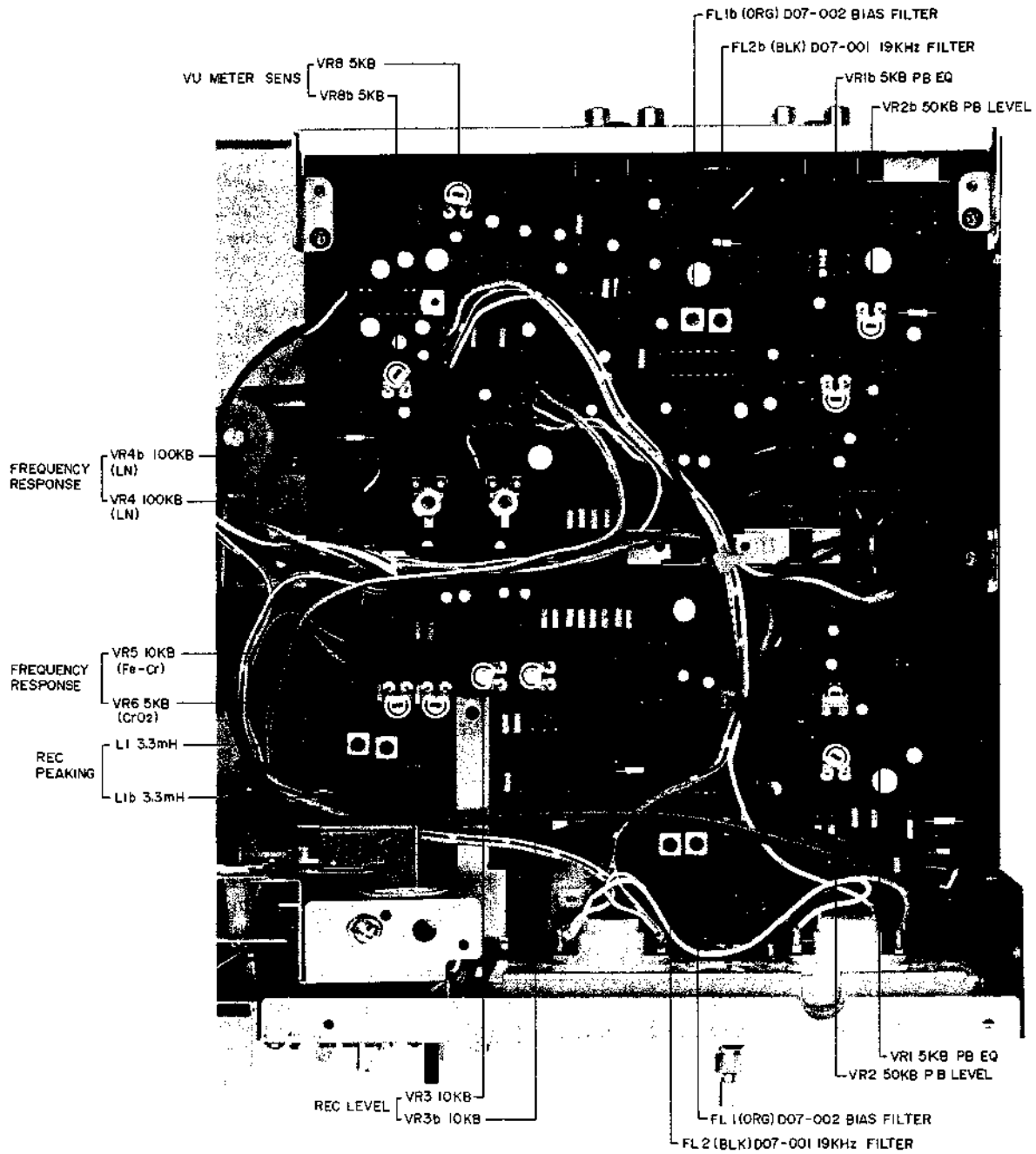

Fig. 18 Pre Amp P.C Board CN-5401A

Step	Adjustment Item	Test Tape Supply Signal	Mode	Adjustment Point	Result	Remarks
1	Playback level adjustment	333 Hz, 0 VU Test Tape	PLAY	VR2 50 kB	-5.5 ±0.5 dBm (410 mV)	
2	VU Meter sensitivity adjustment	333 Hz, 0 VU Test Tape	PLAY	VR8 5 kB	0 VU indication	
3	Playback equalizer adjustment	10 kHz Test Tape	PLAY	VR1 5 kB	-20.0 ±0.5 dBm	
4	Rec peaking adjustment	14 kHz from an oscillator	REC	L1 3.3 mH	Maximum AC voltmeter indication	(Refer to NOTE 6 and Figs. 13, 14)
5	LN Position frequency response adjustment	Low Noise Blank tape 1,000 Hz, 10,000 Hz, -25.5 dBm recording	REC/PLAY	VR4 100 kB	1,000 Hz to 10,000 Hz flat response	
6	CrO ₂ Position frequency response adjustment	CrO ₂ Blank tape, 1,000 Hz 10,000 Hz, -25.5 dBm recording	REC/PLAY	VR6 5 kB	1,000 Hz to 10,000 Hz flat response	Set tape selector to CrO ₂ . (Refer to NOTE 7)
7	Fe-Cr Position frequency response adjustment	Fe-Cr Blank tape 1,000 Hz, 10,000 Hz -25.5 dBm recording	REC/PLAY	VR5 10 kB	1,000 Hz to 10,000 Hz flat response	Set tape selector to Fe-Cr. (Refer to NOTE 7)
8	Recording level adjustment	Low Noise Blank tape, 1,000 Hz, -5.5 dBm recording	REC/PLAY	VR3 10 kB	-5.5 ±0.5 dBm (410 mV)	
9	Distortion Factor Confirmation	1,000 Hz -5.5 dBm recording	REC/PLAY	LN: Less than 1.3% LH: Less than 1.3% CrO ₂ : Less than 2.0% Fe-Cr: Less than 2.0% (Refer to NOTE 8)		
10	Bias Filter adjustment	No signal input	REC	FL1 D07-002 (ORG)	Minimum AC voltmeter indication	Recording volume to maximum. (Refer to NOTE 10)
11	19 kHz filter adjustment	19 kHz from an oscillator	REC	FL2 D07-00 (BLK)	Minimum AC voltmeter indication	(Refer to NOTES 9, 10)

Chart-2

-
- NOTES:**
1. Output Level Control should be at maximum.
 2. Because each of these adjustments are vital to perfect Dolby NR circuit operation, be sure that they are carried out with as little error as possible.
 3. Except for Steps 6, 7 and 9 set tape selector to Low Noise position.
 4. Set Dolby NR switch to OFF position.
 5. Use the following cassette measuring tapes:

LN Tape:	Fuji FL C-60
LH Tape:	Maxell UD C-60
CrO ₂ Tape:	TDK SA C-60
Fe-Cr Tape:	SONY Duad C-60
 6. Stop recording bias oscillator while making Rec Peaking Adjustment (Refer to Fig. 16).
 7. If a flat characteristic cannot be obtained from 1,000 Hz to 10,000 Hz at CrO₂, or Fe-Cr positions, fine adjust at VR6 (CrO₂), or VR5 (Fe-Cr) respectively.
 8. If it does not comply with the specifications, repeat Steps 5 to 8 and re-adjust.
 9. Adjust the oscillators frequency to give a frequency counter reading of 19.00 kHz.
 10. Unless the core is moved intentionally this adjustment is not necessary.

VIII. DC RESISTANCE OF VARIOUS COILS

Parts	Designation	DC Resistance
REC/PB HEAD (CS-703D)	RP-2442-EG-6233	260 ohms \pm 20%
REC/PB HEAD (GXC-704D)	P4-360 Σ	370 ohms
ERASE HEAD	E-621-NM-0338	5 ohms \pm 20%

Chart-3

IX. CLASSIFICATION OF VARIOUS P.C BOARDS

1. P.C BOARD TITLES AND IDENTIFICATION NUMBERS

1) Model CS-703D

P.C Boards Title	P.C Board Number
Pre Amp P.C Board	CN-5501A
Power Supply P.C Board	CN-5403
Power Supply P.C Board	CN-5502
Power Supply P.C Board	CN-5503
Power Supply P.C Board	CN-5504
LED P.C Board	CN-5501B
Lamp P.C Board	CN-5506
Housing Lamp P.C Board	CN-5303

Chart-4

2) Model GXC-704D

P.C Board Title	P.C Board Number
Pre Amp P.C Board	CN-5401A
Power Supply P.C Board	CN-5403
Power Supply P.C Board	CN-5502
Power Supply P.C Board	CN-5503
Power Supply P.C Board	CN-5504
LED P.C Board	CN-5402
Headphone P.C Board	CN-5401B
Housing Lamp P.C Board	CN-5303

Chart-5

2. MODEL CS-703D COMPOSITION OF VARIOUS P.C BOARDS

1) PRE AMP P.C BOARD CN-5501A (2ED) & LED P.C BOARD CN-5501B

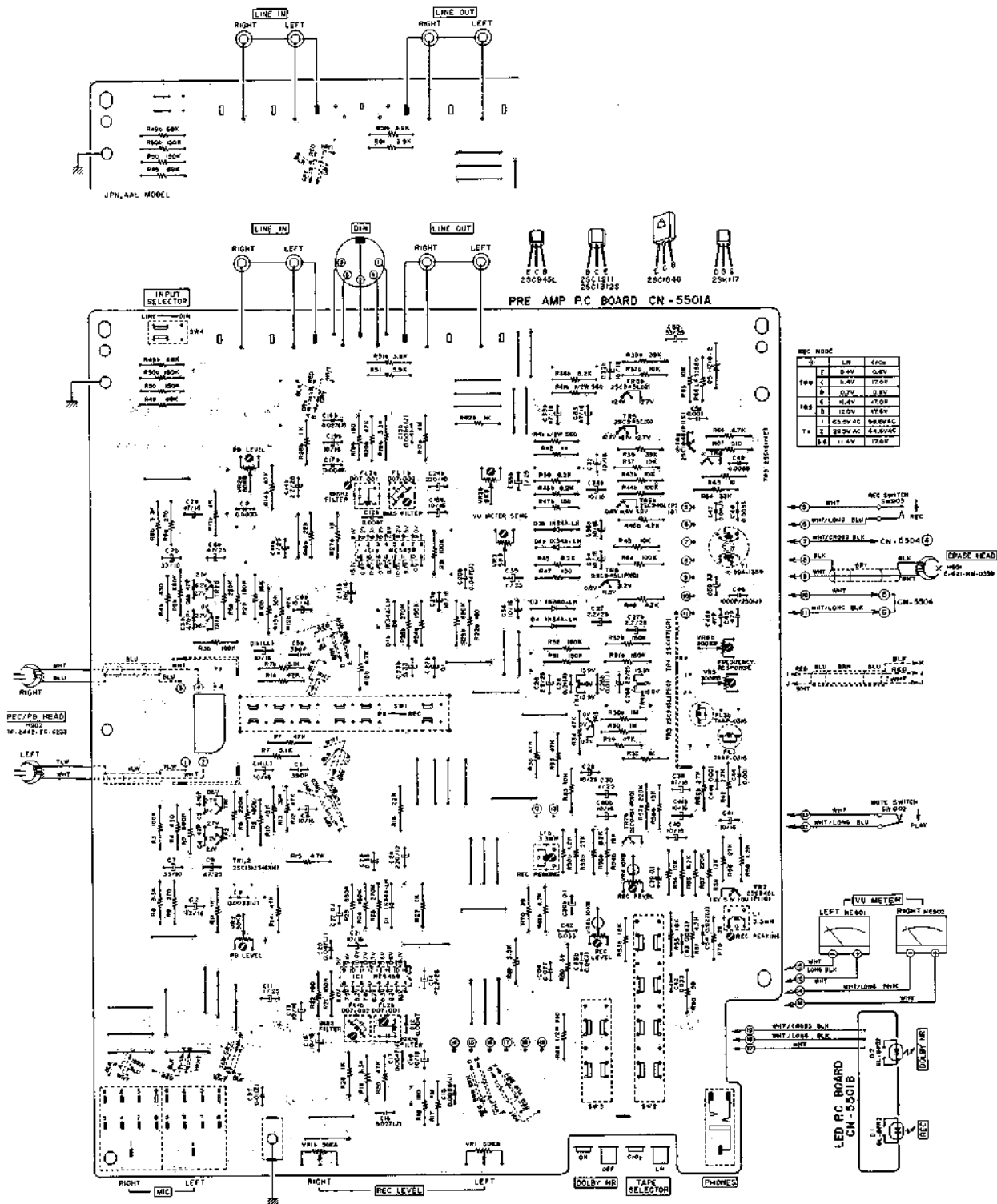

2) POWER SUPPLY P.C BOARD CN-5504, LAMP P.C BOARD CN-5506 & HOUSING LAMP P.C BOARD CN-5303 (U/T)

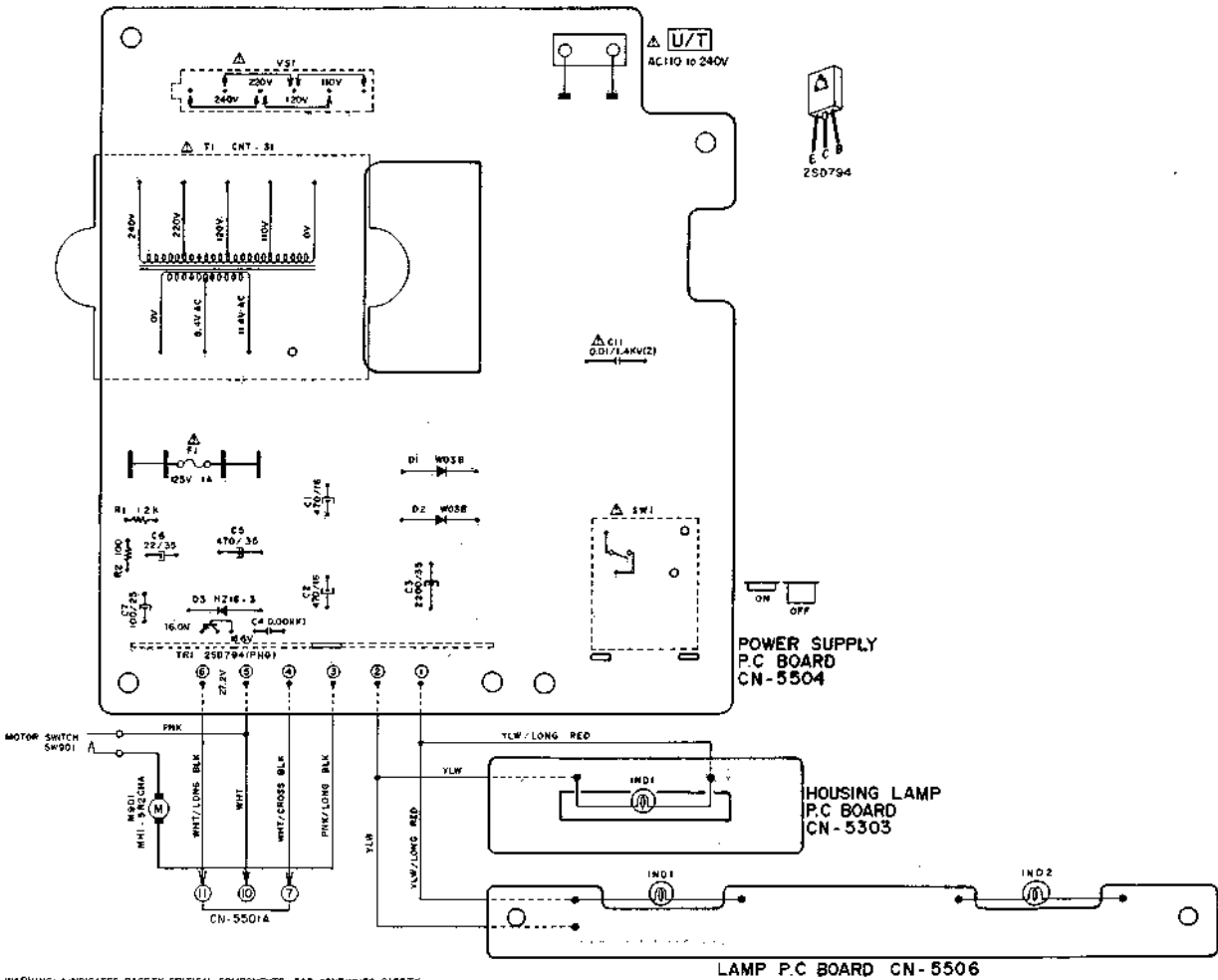

WARNING: Δ INDICATES SAFETY CRITICAL COMPONENTS. FOR CONTINUED SAFETY, REPLACE SAFETY CRITICAL COMPONENTS ONLY WITH MANUFACTURER'S RECOMMENDED PARTS.
 AVERTISSEMENT: Δ IL INDIQUE LES COMPOSANTS CRITIQUES DE SÛRETÉ. POUR MAINTENIR LE DEGRÉ DE SÛRETÉ DE L'APPAREIL, NE REMPLACER LES COMPOSANTS DONT LE FONCTIONNEMENT EST CRITIQUE POUR LA SÛRETÉ QUE PAR DES PIÈCES RECOMMANDÉES PAR LE FABRICANT.

3) POWER SUPPLY P.C BOARD CN-5502, LAMP P.C BOARD CN-5506 & HOUSING LAMP P.C BOARD CN-5303 (CSA, AAL)

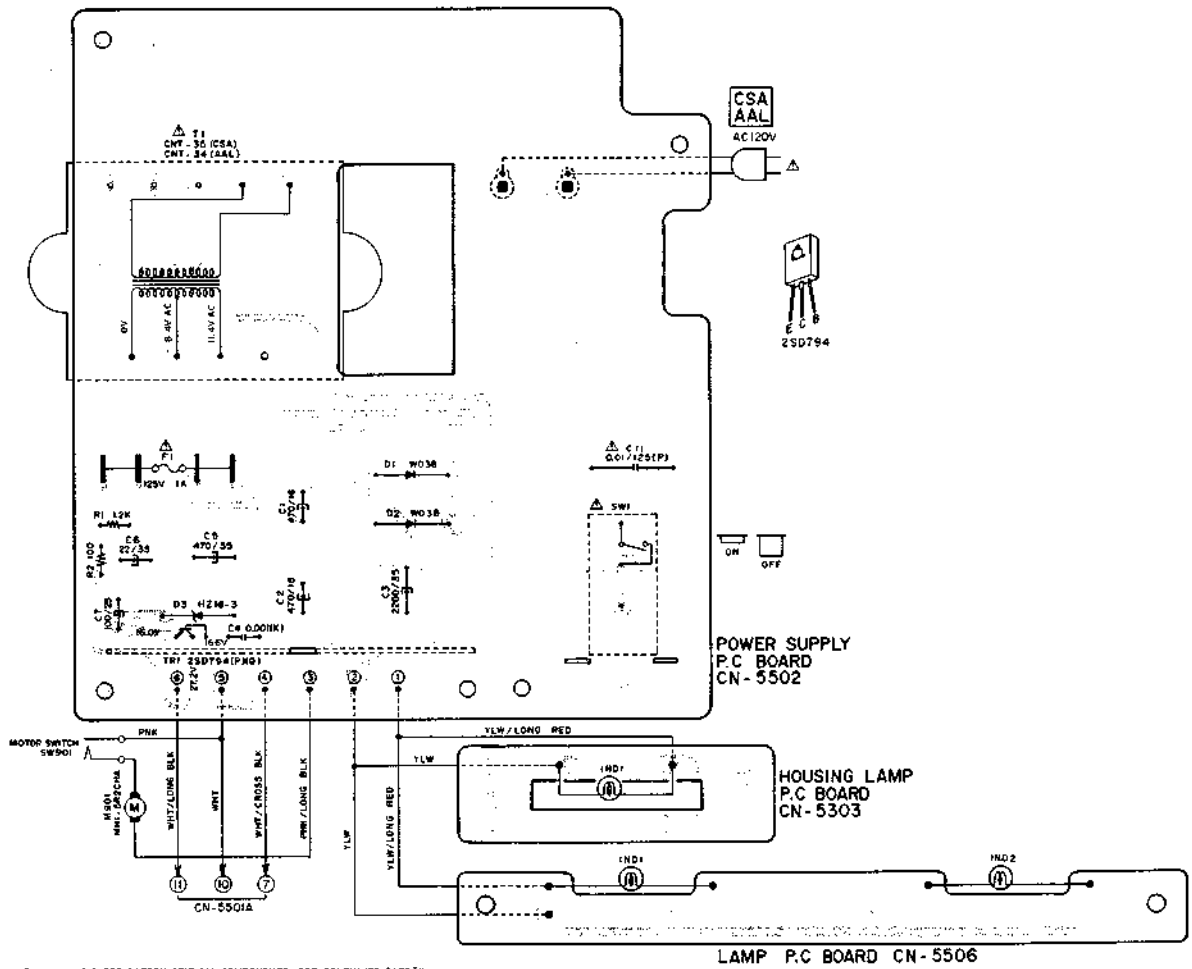

WARNING ⚠ INDICATES SAFETY CRITICAL COMPONENTS FOR CONTINUED SAFETY. REPLACE SAFETY CRITICAL COMPONENTS ONLY WITH MANUFACTURER'S RECOMMENDED PARTS.
 AVERTISSEMENT ⚠ ILL INDIQUE LES COMPOSANTS CRITIQUES DE SÛRETÉ. POUR MAINTENIR LE DEGRÉ DE SÛRETÉ DE L'APPAREIL, NE REMPLACEZ LES COMPOSANTS DONT LE FONCTIONNEMENT EST CRITIQUE POUR LA SÛRETÉ QUE PAR DES PIÈCES RECOMMANDÉES PAR LE FABRICANT.

4) POWER SUPPLY P.C BOARD CN-5503, LAMP P.C BOARD CN-5506 & HOUSING LAMP P.C BOARD CN-5303 (CEE)

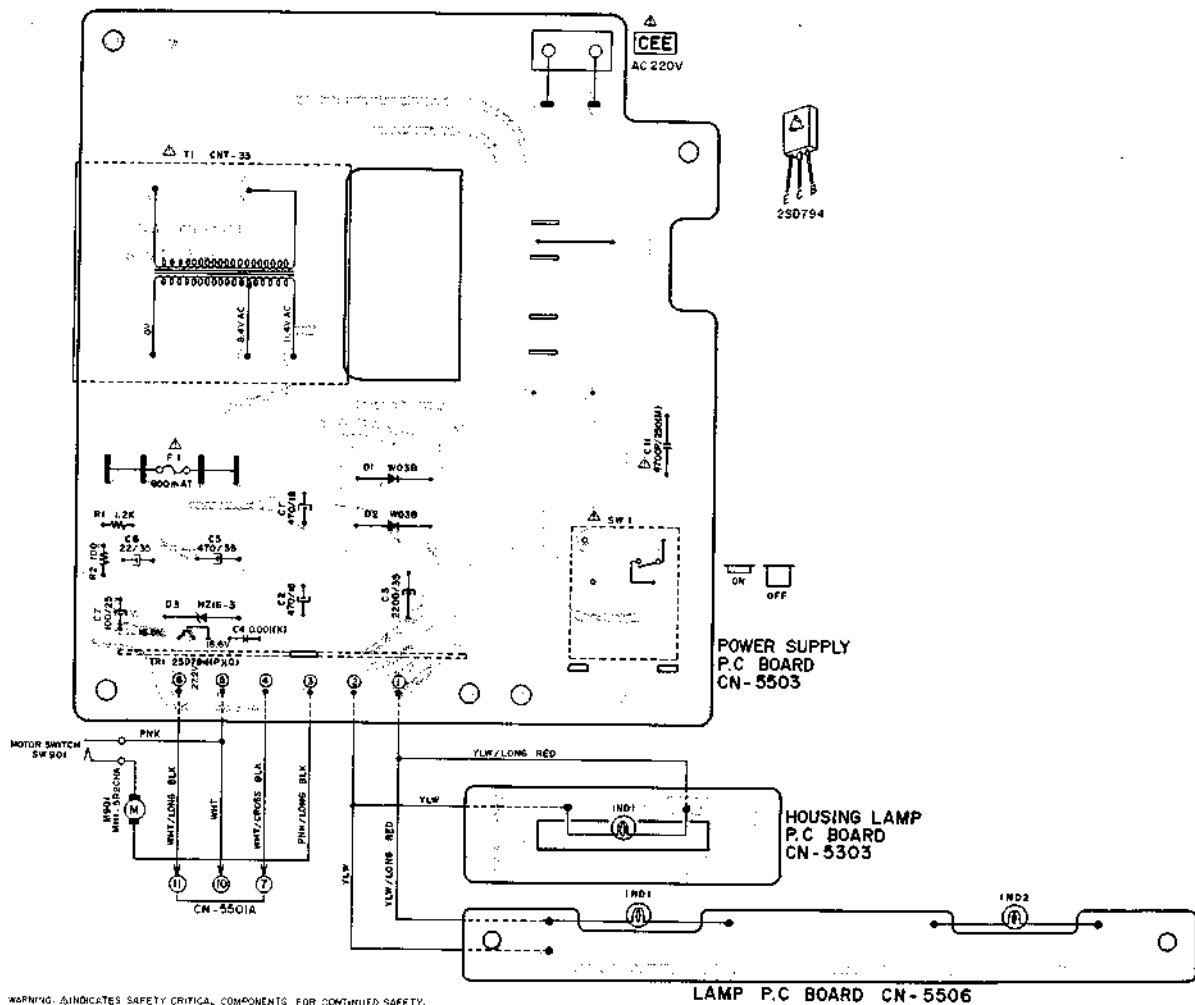

WARNING: Δ INDICATES SAFETY CRITICAL COMPONENTS. FOR CONTINUED SAFETY, REPLACE SAFETY CRITICAL COMPONENTS ONLY WITH MANUFACTURER'S RECOMMENDED PARTS.

AVERTISSEMENT: Δ IL INDIQUE LES COMPOSANTS CRITIQUES DE SÛRETÉ. POUR MAINTENIR LE DEGRÉ DE SÛRETÉ DE L'APPAREIL, NE REMPLACER LES COMPOSANTS DONT LE FONCTIONNEMENT EST CRITIQUE POUR LA SÛRETÉ QUE PAR DES PIÈCES RECOMMANDÉES PAR LE FABRICANT.

5) POWER SUPPLY P.C BOARD CN-5503, LAMP P.C BOARD CN-5506 & HOUSING LAMP P.C BOARD CN-5303 (UK)

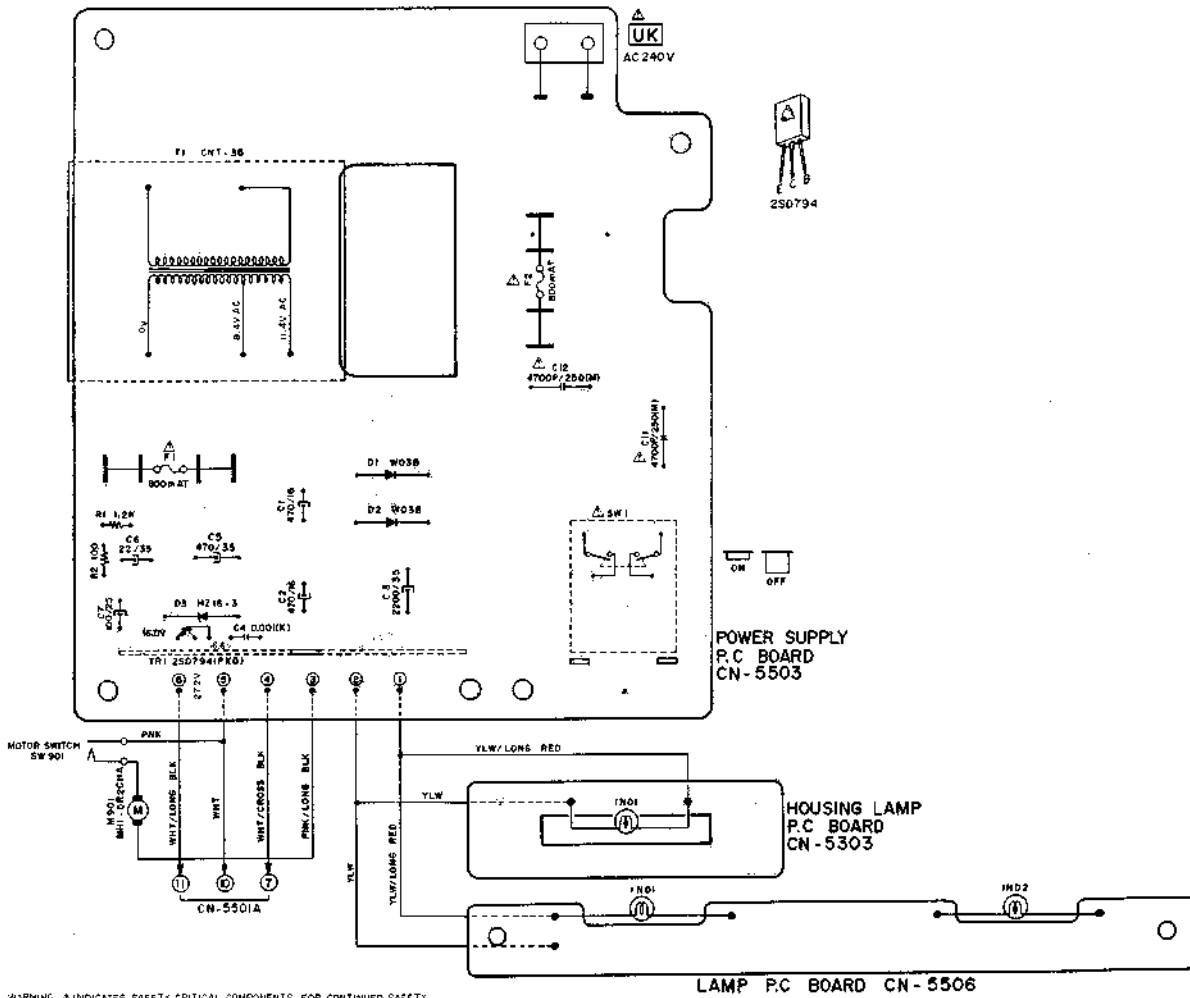

6) POWER SUPPLY P.C BOARD CN-5403, LAMP P.C BOARD CN-5506 & HOUSING LAMP P.C BOARD CN-5303 (JPN)

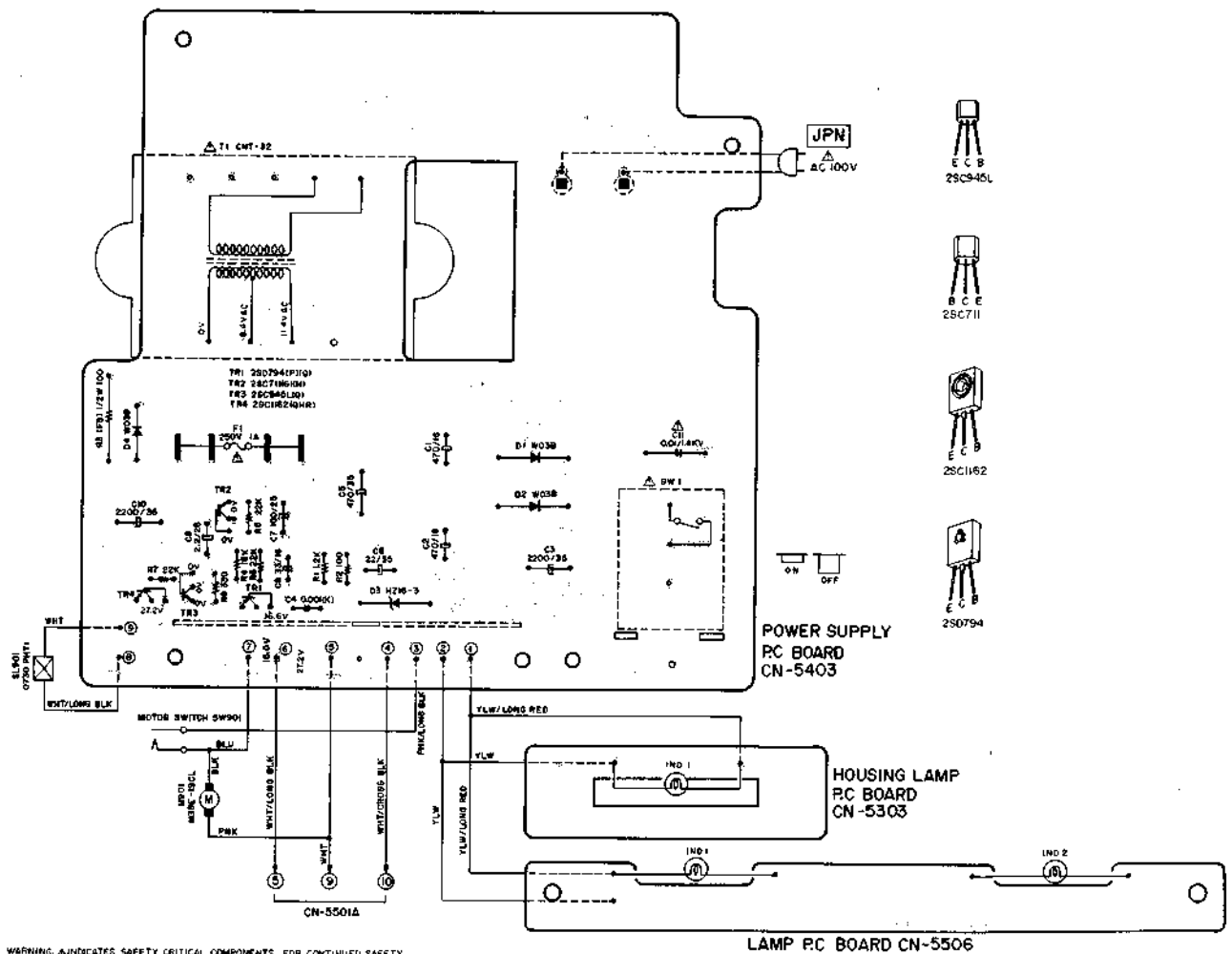

WARNING: Δ INDICATES SAFETY CRITICAL COMPONENTS. FOR CONTINUED SAFETY, REPLACE SAFETY CRITICAL COMPONENTS ONLY WITH MANUFACTURER'S RECOMMENDED PARTS.

AVERTISSEMENT: Δ IL INDIQUE LES COMPOSANTS CRITIQUES DE SÛRETÉ. POUR MAINTENIR LE DEGRÉ DE SÛRETÉ DE L'APPAREIL, NE REMPLACER LES COMPOSANTS DONT LE FONCTIONNEMENT EST CRITIQUE POUR LA SÛRETÉ QUE PAR DES PIÈCES RECOMMANDÉES PAR LE FABRICANT.

3. MODEL GXC-704D COMPOSITION OF VARIOUS P.C BOARDS

1) PRE AMP P.C BOARD CN-5401A, LED P.C BOARD CN-5402 & HEADPHONE P.C BOARD CN-5401B

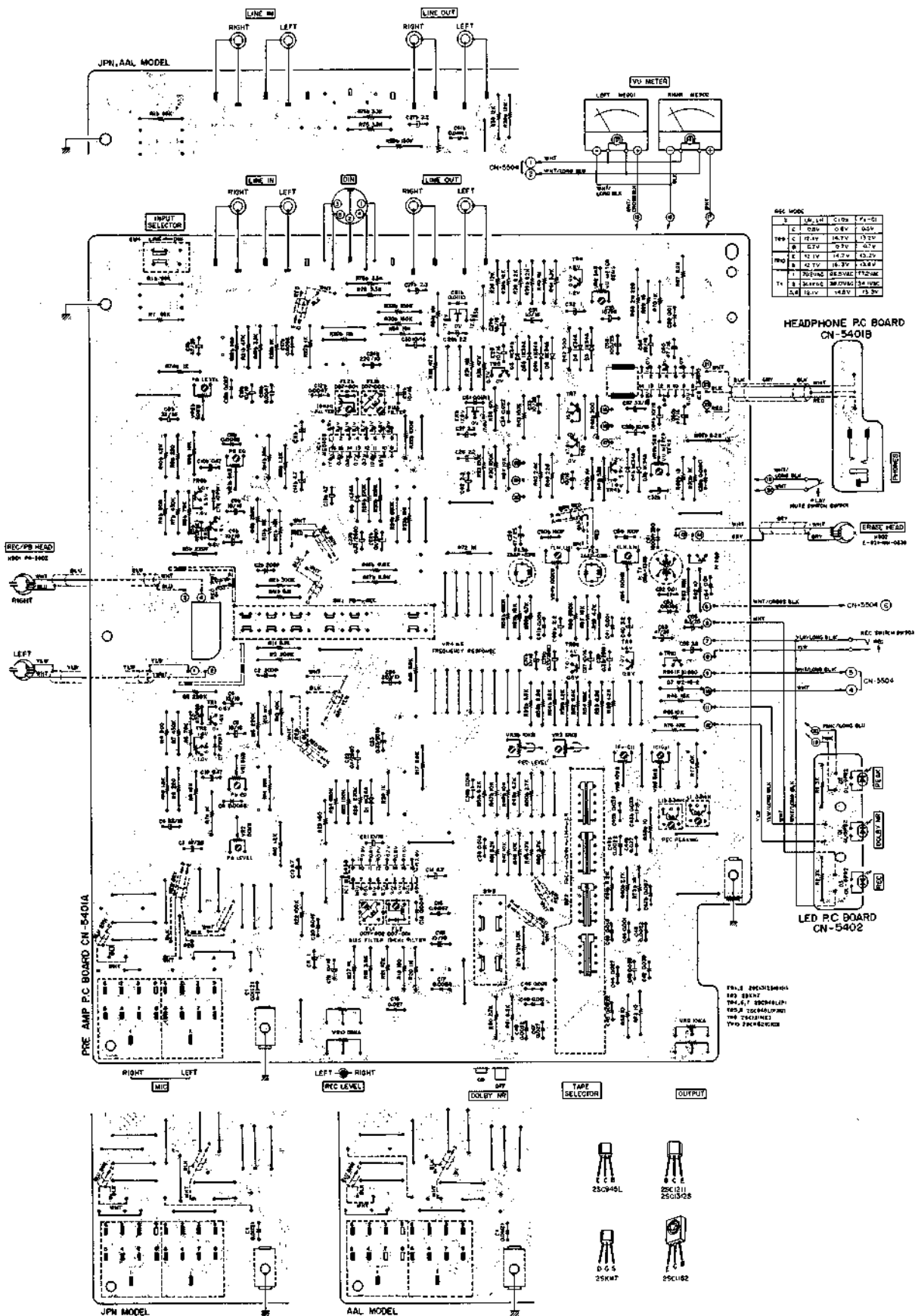

2) POWER SUPPLY P.C BOARD CN-5504 & HOUSING LAMP P.C BOARD CN-5303 (U/T)

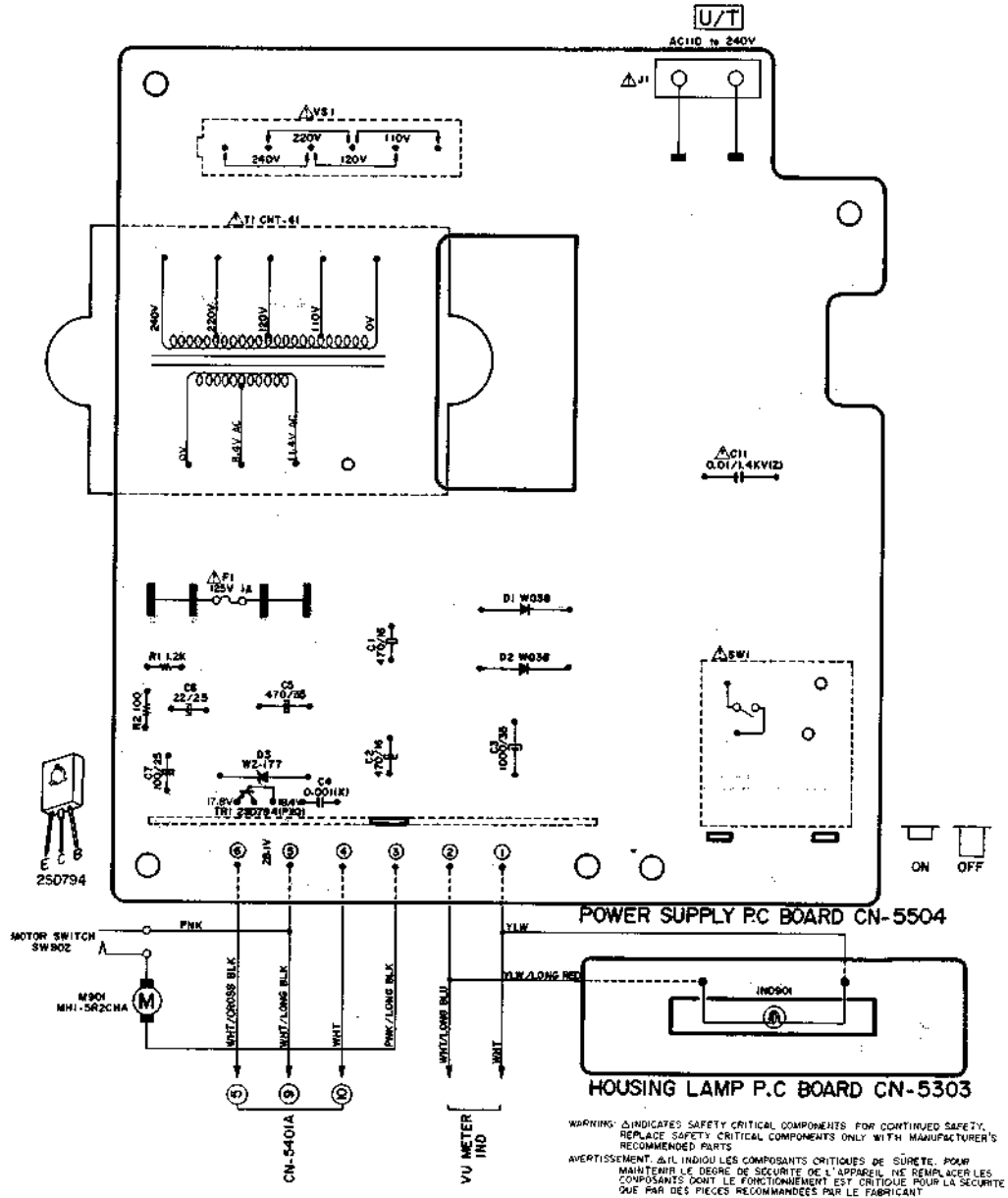

3) POWER SUPPLY P.C BOARD CN-5502 & HOUSING LAMP P.C BOARD CN-5303 (CSA, AAL)

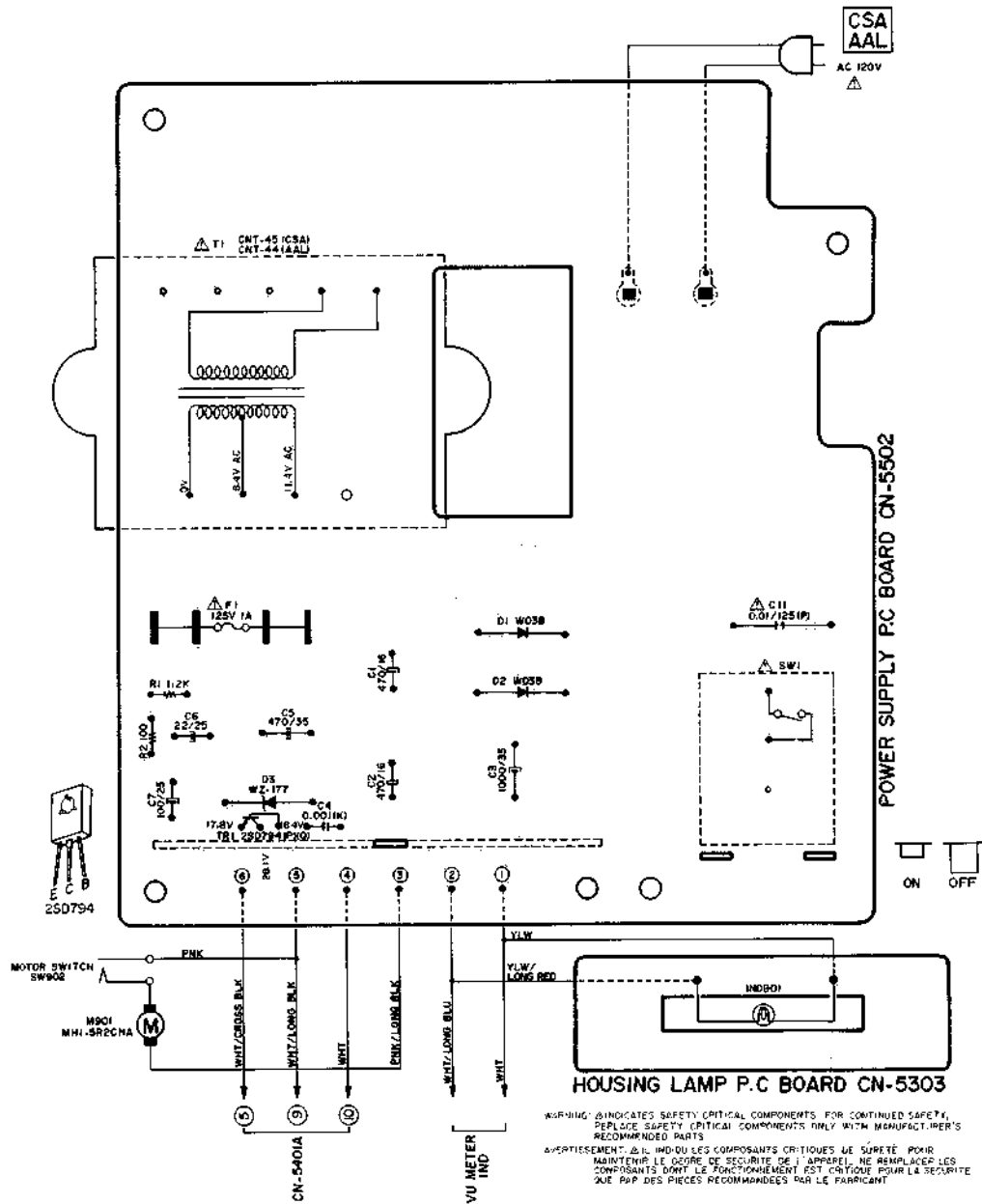

4) POWER SUPPLY P.C BOARD CN-5503 & HOUSING LAMP P.C BOARD CN-5303 (CEE)

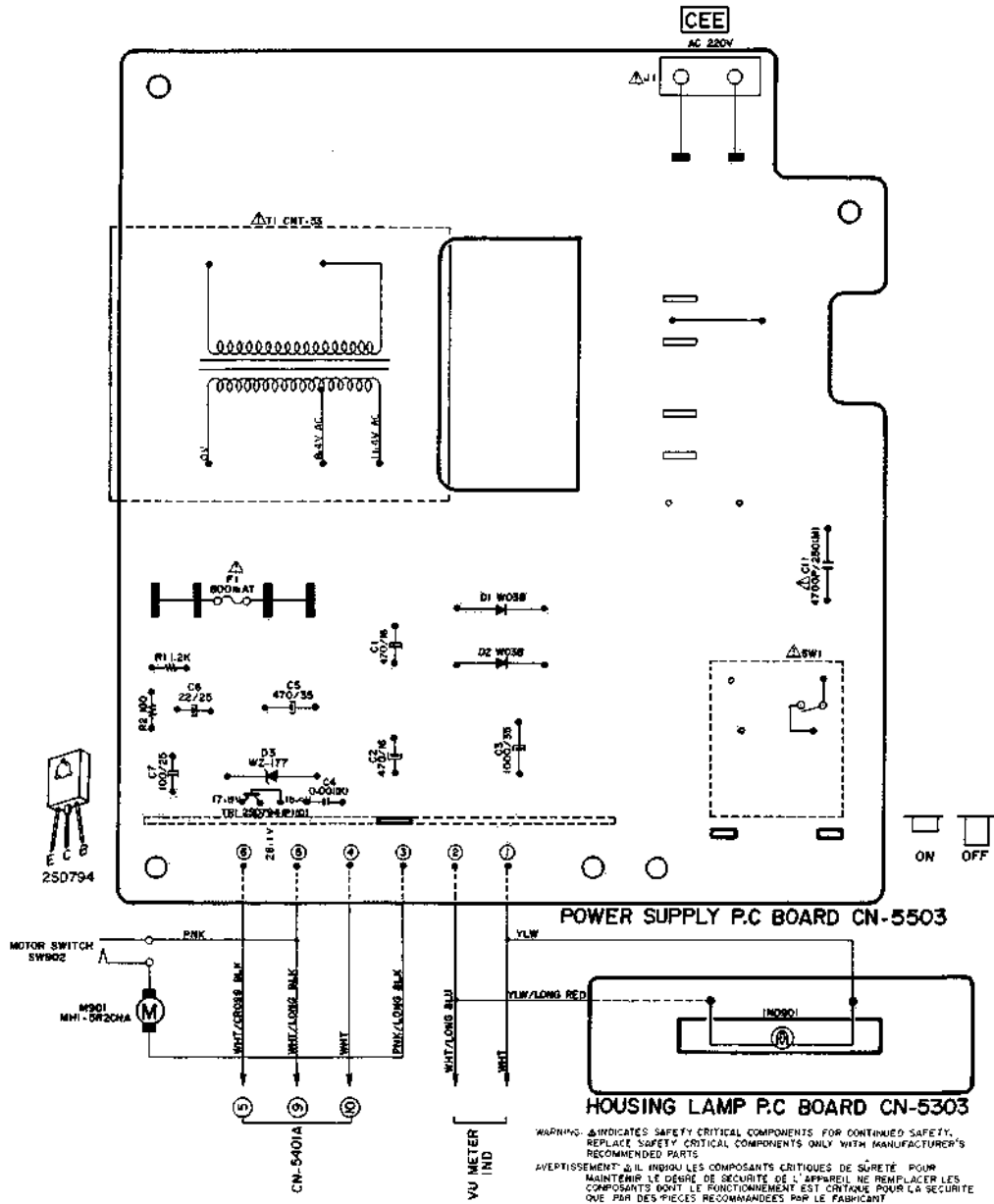

5) POWER SUPPLY P.C BOARD CN-5503 & HOUSING LAMP P.C BOARD CN-5303 (UK)

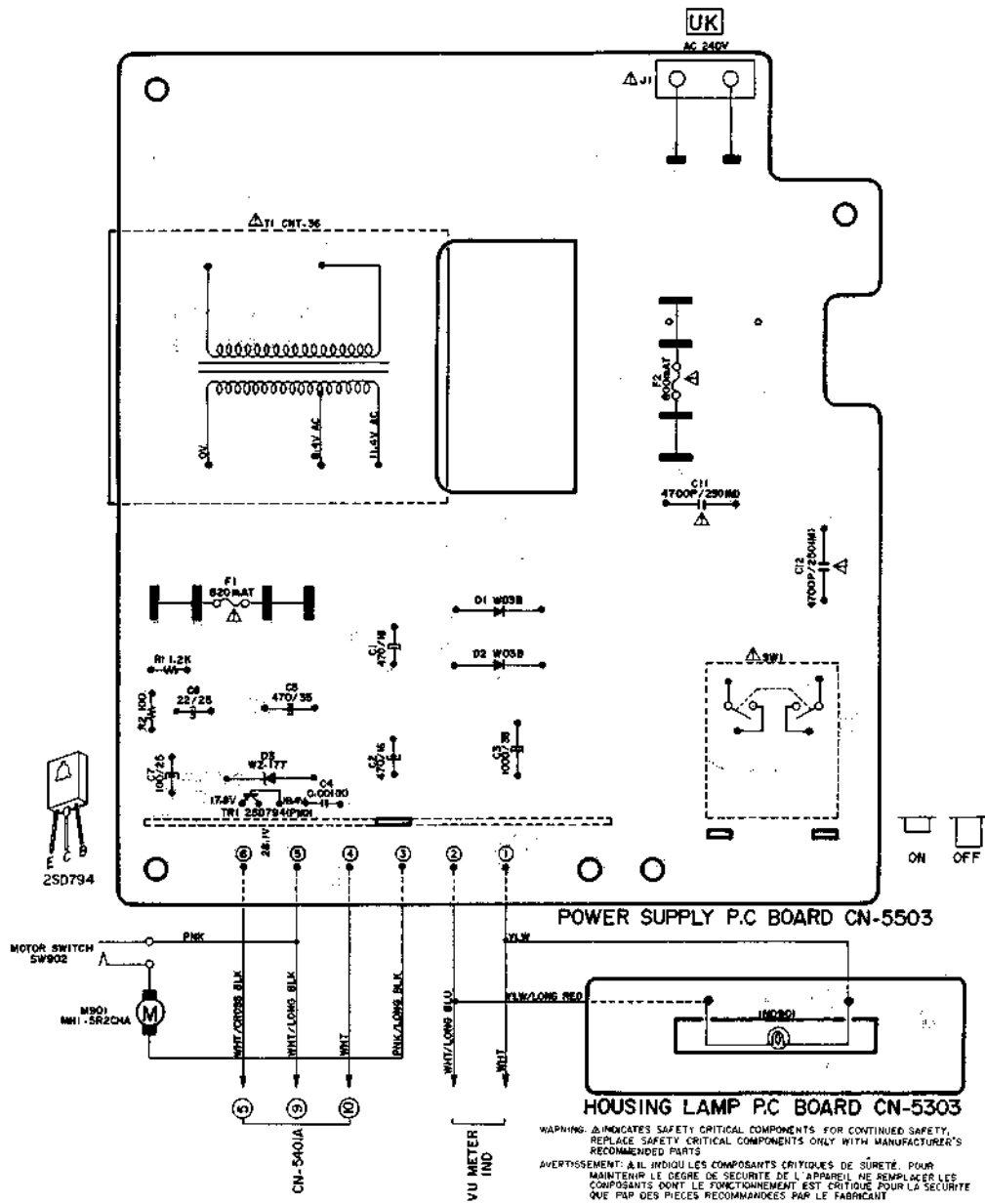

6) POWER SUPPLY P.C BOARD CN-5403 & HOUSING LAMP P.C BOARD CN-5303 (JPN)

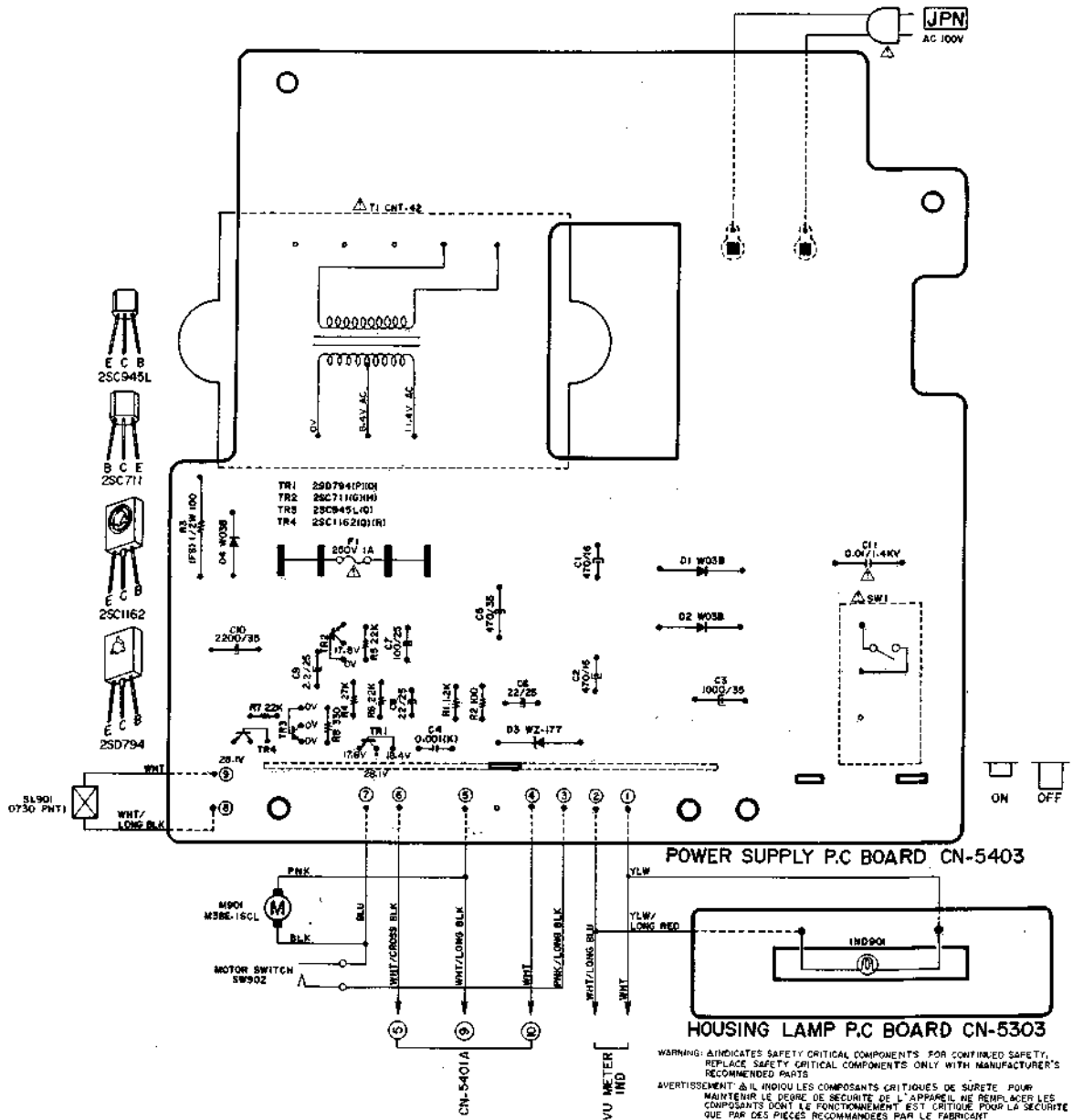

MEMO

MEMO

MEMO

MEMO

SECTION 2

PARTS LIST

TABLE OF CONTENTS

1. RECOMMENDED SPARE PARTS LIST	42
MODEL CS-703D	
2. HEAD BASE BLOCK	44
3. MOTOR BLOCK	45
4. MECHA FRAME BLOCK	46
5. P.C BOARDS	48
(1) PRE AMP P.C BOARD (CN-5501A) BLOCK	48
(2) POWER SUPPLY P.C BOARD (CN-5502/5503/5504, CN-5303) BLOCK	48
6. FINAL ASSEMBLY BLOCK (1)	49
7. FINAL ASSEMBLY BLOCK (2)	50
MODEL GXC-704D	
8. HEAD BLOCK	52
9. MOTOR BLOCK	53
10. MECHA FRAME BLOCK	54
11. P.C BOARDS	56
(1) PRE AMP P.C BOARD (CN-5401A) BLOCK	56
(2) POWER SUPPLY P.C BOARD (CN-5502/5503/5504, CN-5303) BLOCK	56
12. AMP CHASSIS BLOCK	57
13. FINAL ASSEMBLY BLOCK	58
14. LIST OF INTERCHANGEABLE SEMICONDUCTORS	60
INDEX	61

Resistor and Capacitor which is not listed in this parts list, please refer to COMMON LIST FOR SERVICE PARTS.

HOW TO USE THIS PARTS LIST

1. This parts list is compiled by various individual blocks based on assembly process.
2. When ordering parts, please describe parts number, serial number, and model number in detail.
3. How to read List

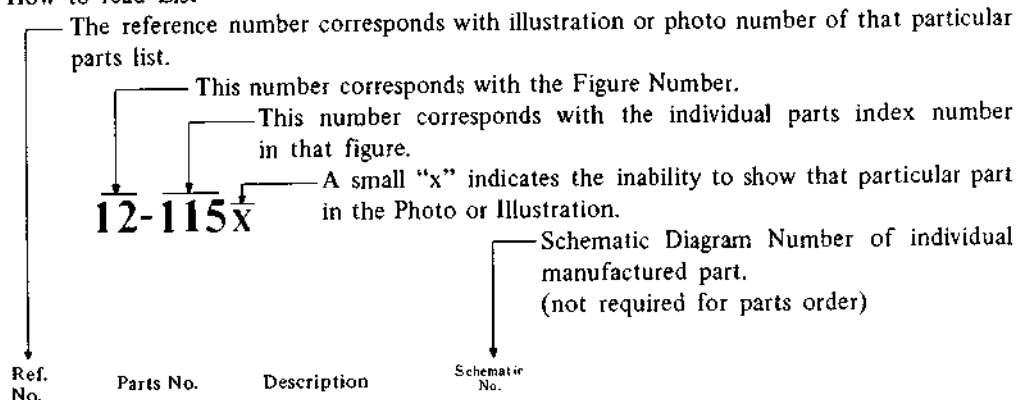

FLYWHEEL BLOCK #13

Ref. No.	Parts No.	Description	Schematic No.
12-115x	800425	Flywheel Block Assy. Comp.	RDG #13
12-116	244506	Flywheel Only	RD-233
12-117x	244754	Felt, Flywheel	RD-275
12-118	251324	Main Metal Case	RD-236
12-119	253080	Main Metal	RD-237

4. The symbol numbers shown on the P.C. Board list can be matched with the Composite Views of Components of the Schematic Diagram or Service Manual.
5. Please utilize separate "Common List for Service Parts" for Resistor Parts orders.
6. The shape of the parts and parts name, etc. can be confirmed by comparing them with the parts shown on the Electrical Parts Table of P.C. Board.
7. Both the kind of part and installation position can be determined by the Parts Number. To determine where a parts number is listed, utilize Parts Index at end of Parts List.
It is necessary first of all to find the Parts Number. This can be accomplished by using the Reference Number listed at right of parts number in the Parts Index. (meaning of ref. no. outlined in Item 3 above).
8. Utilize separate "Price List for Parts" to determine unit price. The most simple method of finding parts Price is to utilize the reference number.

- CAUTION:**
1. When placing an order for parts, be sure to list the parts no. model no., and description. There are instances in which if any of this information is omitted, parts cannot be shipped or the wrong parts will be delivered.
 2. Please be careful not to make a mistake in the parts no. If the parts no. is in error, a part different from the one ordered may be delivered.
 3. Because parts number and parts unit supply in the Preliminary Service Manual (Basic Parts List) may be partially changed, please use this parts list for all future reference.

WARNING: \triangle INDICATES SAFETY CRITICAL COMPONENTS. FOR CONTINUED SAFETY, REPLACE SAFETY CRITICAL COMPONENTS ONLY WITH MANUFACTURER'S RECOMMENDED PARTS.

AVERTISSEMENT: \triangle IL INDIQU LES COMPOSANTS CRITIQUES DE SURETE. POUR MAINTENIR LE DEGRE DE SECURITE DE L'APPAREIL NE REMPLACER LES COMPOSANTS DONT LE FONCTIONNEMENT EST CRITIQUE POUR LA SECURITE QUE PAR DES PIECES RECOMMANDEES PAR LE FABRICANT.

AC INLET SYSTEM

This model is equipped with an AC INLET SYSTEM. Please refer to the AC INLET SYSTEM CHART below for the specific type. By the AC INLET SYSTEM, AC (mains) cord can be connected to and disconnected from the model because the model is provided with socket exclusively for AC (mains) cord on its main body. Please note, however, that certain models are not equipped with this system and has a built-in AC (mains) cord as before.

AC INLET SYSTEM CHART

CLASS I

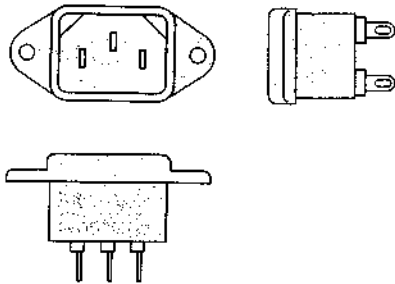

Picture 1
AC INLET
to be
installed
on machines

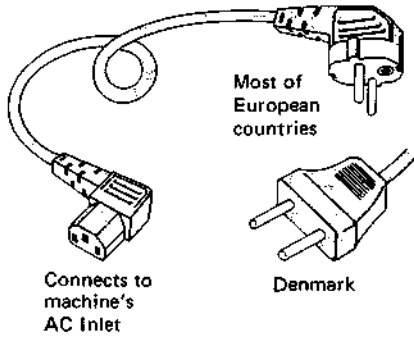

CLASS II

☐ This mark indicating double insulation will be attached to machine's rear panel

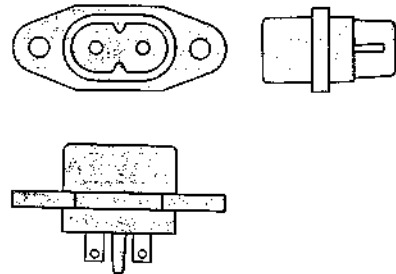

Connects to
machine's
AC Inlet

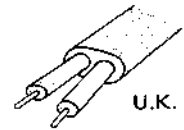
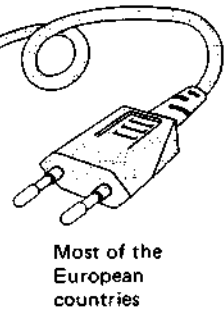

Picture 2
AC (mains)
cord

Parts List for AC (mains) Cord Set

Standard		Description	Type of AC Inlet	Parts No.
Class I	CEE	Cord Set CEE (3 cores)	3P	EW302993
	BEAB	Cord Set BEAB (3 cores)	3P	EW302994
	SAA	Cord Set SAA (3 cores)	3P	EW302996
	U/T	Cord Set U/T (3 cores)	3P	EW302646
Class II	CEE	Cord Set CEE (2 cores)	2P	EW638144
	BEAB	Cord Set BEAB (2 cores)	2P	EW302995
	SAA	Cord Set SAA (2 cores)	2P	EW302991
	U/T	Cord Set U/T (2 cores)	2P	EW302899

1. RECOMMENDED SPARE PARTS LIST

Because, if the parts listed below are on hand, almost any repair can be accomplished, we suggest that you stock these Recommended Spare Parts Items.

CS-703D

Parts No.	Description	Note
BA311108	Pre Amp P.C Board Comp. CS-703D (U/T)	U/T, CSA, CEE, UK
BA311110	Pre Amp P.C Board Comp. CS-703D-J	JPN
BA311158	Power Supply P.C Board Comp. CS-703D (U/T)	
BA311159	Power Supply P.C Board Comp. CS-703D (CSA)	
BA311160	Power Supply P.C Board Comp. CS-703D (CEE)	
BA311161	Power Supply P.C Board Comp. CS-703D (UK)	
BA311162	Power Supply P.C Board Comp. CS-703D-J	JPN
BF305887	Flywheel Part GXC-706D	Same as GXC-704D/GXC-706D
BK311346	Keyboard Block Comp. CS-703D	
BK305798	Keyboard Comp. (B) CN-2 (BL)	BL
BL282510	Middle Lever Part	Same as GXC-704D
BL300249	Pinch Roller Block Comp. GXC-709D	
BL282508	Take-up Lever Part	Same as GXC-706D
BM274230	Motor Block Comp. CN	Same as GXC-704D
BT310566	Power Trans. CNT-31	U/T
BT310562	Power Trans. CNT-32	JPN
BT310564	Power Trans. CNT-33	CEE
BT310563	Power Trans. CNT-34	AAL
BT310858	Power Trans. CNT-35	CSA
BT310565	Power Trans. CNT-36	UK
BZ282881	Auto Stop Comp.	Same as GXC-704D
ED308953	Germanium Diode (Home. Type) 1K34A-LH	
ED310585	LED GL-9PG2	
ED310584	LED GL-9PR2	
ED306109	Silicon Diode W03B	
ED313846	Zener Diode HZ16-3	
ED310607	Zener Diode HZ18-2	
EI605013	IC NE545B	
EL301541	Lamp (Lead Type) 8V 55 MA	
EM310600	VU Meter KL-289S-1	
EM312409	VU Meter MG-118S	
EO283050	OSC. Coil 09A-1359	Same as GXC-706D
EO310875	Trap Coil 7AAP-0316	Same as GXC-706D
EP300424	Plunger 0730PHTI	Same as GXC-704D
ER309119	Dolby Filter D07-001	Same as GXC-706D
ER309361	Dolby Filter D07-002	Same as GXC-706D
ET303697	FET 2SK117 (GR)	
ET301154	Transistor 2SC1162 (C) (D)	
ET520266	Transistor 2SC1211 (E)	
ET603257	Transistor 2SC1312S (G) (H)	
ET310920	Transistor 2SC1846 (R) (S)	
ET563905	Transistor 2SC711 (G) (H)	
ET399846	Transistor 2SC945L (Q)	
ET639437	Transistor 2SC945L (Q) (P)	
ET398711	Transistor 2SC945L (Q) (R)	
HE310582	ERASE HEAD E-621-NM-0338	
HP310602	REC/PB HEAD RP-2442-EG-6233	
MB283421	AS Belt	Same as GXC-704D
MB282093	Capstan Belt	Same as GXC-704D
MB313845	Counter Belt	Same as GXC-704D
MC310536	Counter ME360-003	Same as GXC-704D
MT305770	Supply Reel Table (B) Part	Same as GXC-704D
MT305769	Take-up Reel Table (B) Part	Same as GXC-704D
TC282161	RWD Wheel	Same as GXC-706D

GXC-704D

Parts No.	Description	Note
BA311056	Pre Amp P.C Board Comp. GXC-704D	
BA311057	Pre Amp P.C Board Comp. GXC-704D-J	JPN
BA311379	Pre Amp P.C Board Comp. GXC-704D (AAL)	
BA311067	Power Supply P.C Board Comp. GXC-704D (U/T)	
BA311068	Power Supply P.C Board Comp. GXC-704D (CSA)	
BA311069	Power Supply P.C Board Comp. GXC-704D (CEE)	
BA311070	Power Supply P.C Board Comp. GXC-704D (UK)	
BA311071	Power Supply P.C Board Comp. GXC-704D-J	JPN
BF305887	Flywheel Part GXC-706D	Same as CS-703D/GXC-706D
BK311328	Keyboard Block Comp. GXC-704D	
BK311329	Keyboard Block Comp. GXC-704D-BL	BL
BL282510	Middle Lever Part	Same as CS-703D
BL311391	Pinch Roller Block Comp. GXC-704D	
BL282508	Take-up Lever Part	Same as CS-704D
BM274230	Motor Block Comp. CN	Same as CS-703D
BT310564	Power Trans. CNT-33	CEE
BT310565	Power Trans. CNT-36	UK
BT313831	Power Trans. CNT-41	U/T
BT313832	Power Trans. CNT-42	JPN
BT313833	Power Trans. CNT-44	AAL
BT313834	Power Trans. CNT-45	CSA
BZ282881	Auto Stop Comp.	Same as CS-703D
ED309341	Germanium Diode 1K34A	
ED306109	Silicon Diode W03B	
ED624903	Silicon Diode 1S2473	
ED310607	Zener Diode HZ18-2	
ED310578	Zener Diode WZ-177	
EI605013	IC NE545B	
EI306141	IC LA4170	
EM305634	VU Meter S11ADR68B	
EM306132	VU Meter S11ADR68C	
EO283050	OSC. Coil 09A-1359	Same as CS-704D
EO310875	Trap Coil 7AAP-0316	Same as CS-704D
EP300424	Plunger 0730PHTI	Same as CS-704D
ER309119	Dolby Filter D07-001	Same as CS-704D
ER309361	Dolby Filter D07-002	Same as CS-704D
ET303697	FET 2SK117 (GR)	
ET301154	Transistor 2SC1162 (C) (D)	
ET520266	Transistor 2SC1211 (E)	
ET603257	Transistor 2SC1312S (G) (H)	
ET563905	Transistor 2SC711 (G) (H)	
ET638504	Transistor 2SC945L (P)	
ET399846	Transistor 2SC945L (Q)	
ET639437	Transistor 2SC945L (Q) (P)	
ET307349	Transistor 2SD794 (P) (Q)	
HE310582	ERASE HEAD E-621-NM-0338	
HP310933	REC/PB HEAD P4-361 (Sigma)	
MB283421	AS Belt	Same as CS-703D
MB282093	Capstan Belt	Same as CS-703D
MB313845	Counter Belt	Same as CS-703D
MC310536	Counter ME360-003	Same as CS-703D
MT305770	Supply Reel Table (B) Part	Same as CS-703D
MT305769	Take-up Reel Table (B) Part	Same as CS-703D
TC282161	RWD Wheel	Same as CS-703D

2. ILLUSTRATION OF HEAD BASE BLOCK

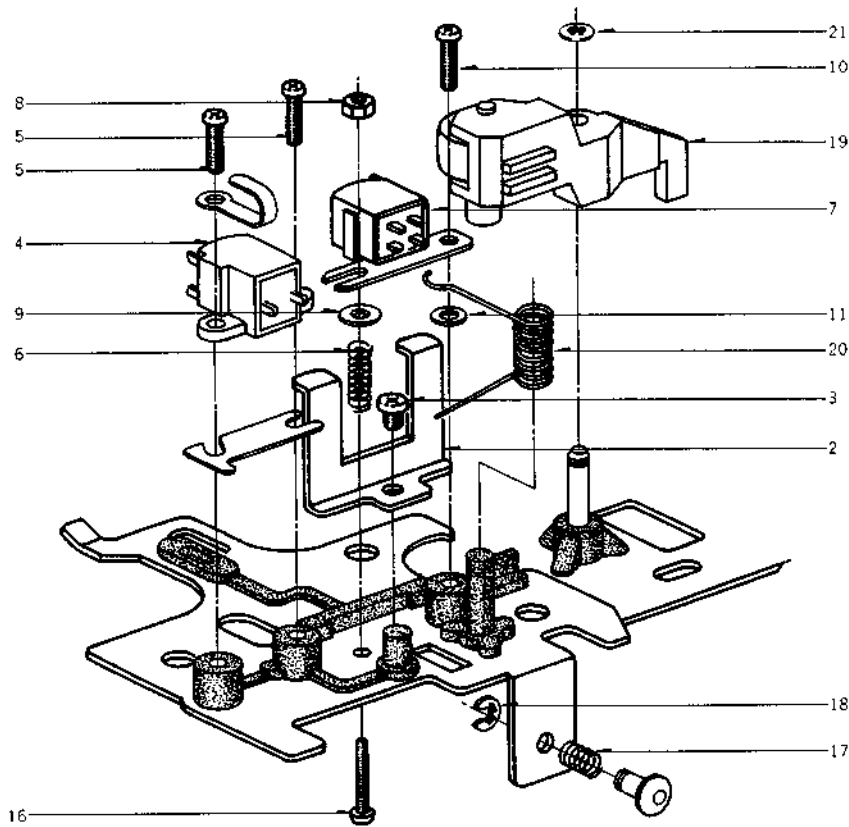

2) HEAD BASE BLOCK

Ref. No.	Parts No.	Description	Schematic No.
2-1x	BH312065	Head Base Block Comp. CS-703D	
2-2	TC282025	Safety Base	CN-0003
2-3	ZS432674	Screw, Pan Head 3x3	
2-4	HE310582	Erase Head E-621-NM-0338	37-2-17
2-5	ZS300436	Tapping Screw #2, 2.3x8 (Bind)	
2-6	ZG282036	Adjust. Spring	CN-0004
2-7	HP310602	REC/PB Head RP-2442-EG-6233	37-2-18
2-8	ZW273734	Nut #1 M2	
2-9	ZW305492	Washer (Polyslider)	
2-10	ZS522180	Tapping Screw #2, 2x8 (Pan)	
2-11	ZW300883	Washer D2.3x6x0.1t PBP	
2-12x	ZW300884	Washer D2.3x6x0.15t PBP	
2-13x	ZW300885	Washer D2.3x6x0.2t PBP	
2-14x	ZW300886	Washer D2.3x6x0.25t PBP	
2-15x	ZW300887	Washer D2.3x6x0.3t PBP	
2-16	ZS306126	Screw, Pan Head 2x12	
2-17	ZG298350	Spring (B)	CN-1068
2-18	ZW270088	'E' Ring 1.9M	6-1-9
2-19	BL300249	Pinch Roller Block Comp. GXC-709D	CN-9708
2-20	ZG282374	Pinch Roller Spring	CN-1053
2-21	ZW282407	Push Washer (B)	CN-1056

When ordering parts, Please describe Parts Number, Description, and Model Number in detail.

3. ILLUSTRATION OF MOTOR BLOCK

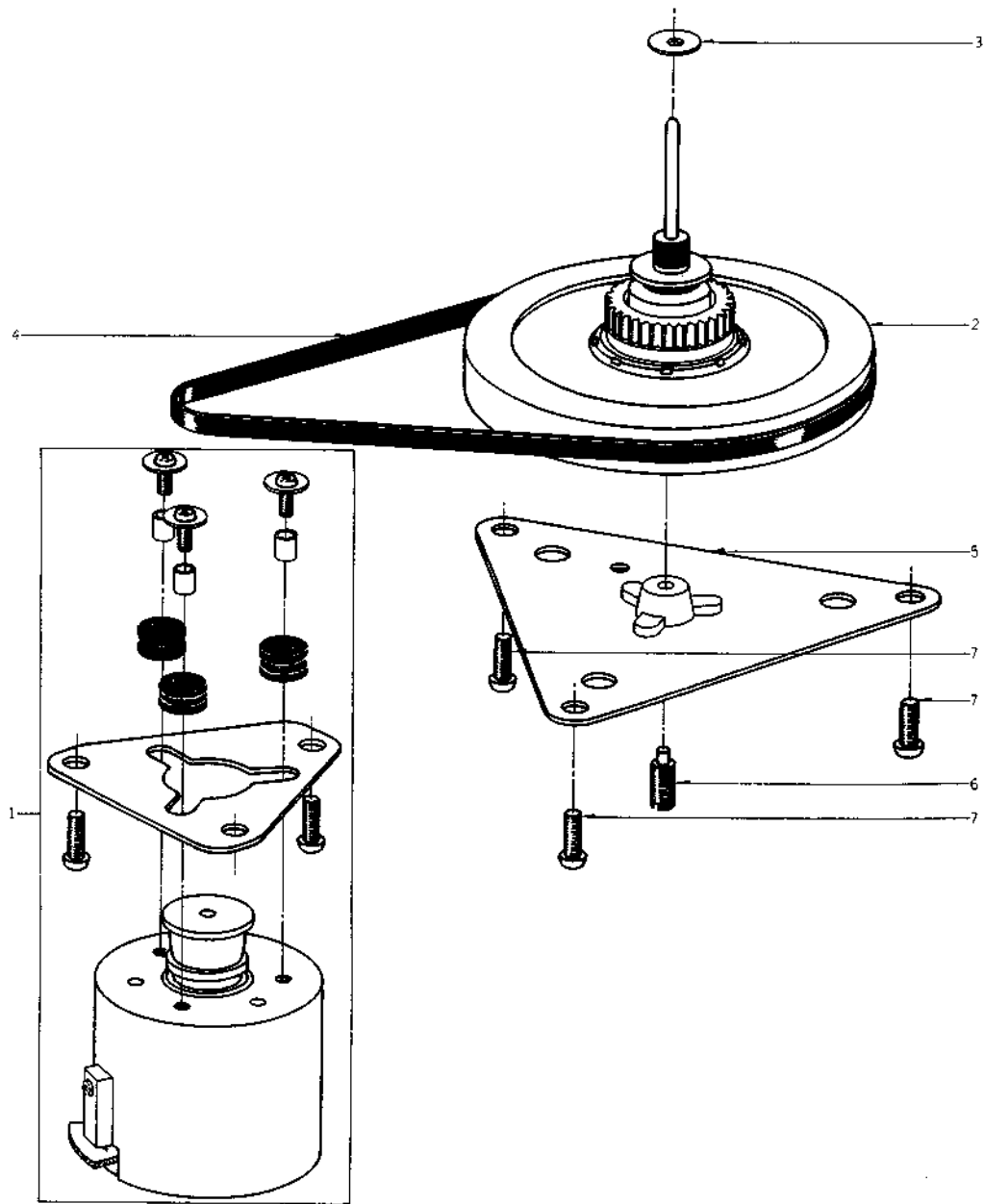

3) MOTOR BLOCK

Ref. No.	Parts No.	Description	Schematic No.
3-1	BM274230	Motor Block Comp. CN	
3-2	BF305887	Flywheel Part GXC-706D	
3-3	ZW282442	Thrust Washer	CN-1060
3-4	MB282093	Capstan Belt	CN-1017
3-5	BZ280337	Flywheel Holder Plate Part	CN-1018
3-6	ZS297628	Adjust Screw	CN-1069
3-7	ZS447840	Tapping Screw #2, 3×8 (BR)	

When ordering parts, Please describe Parts Number, Description, and Model Number in detail.

4. ILLUSTRATION OF MECHA FRAME BLOCK

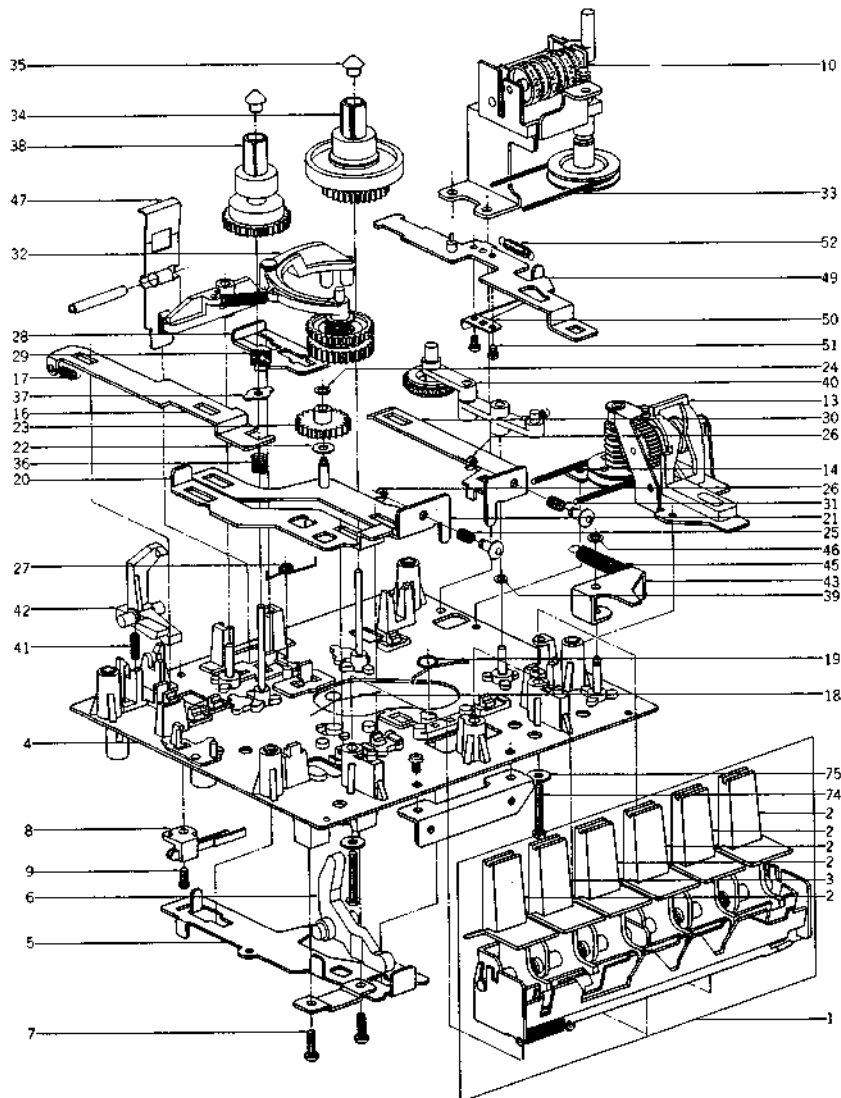
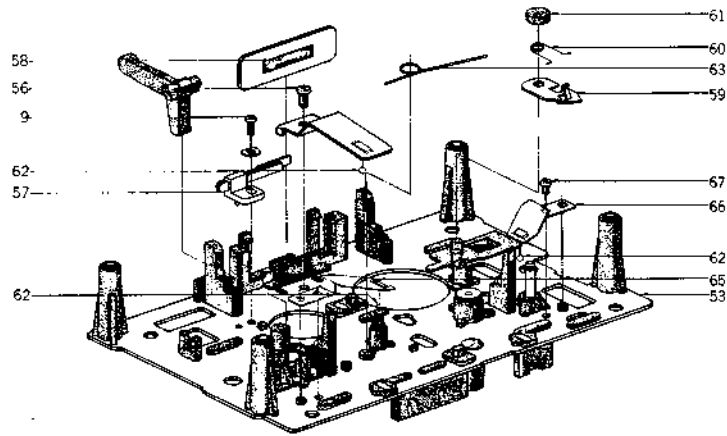

4) MECHA FRAME BLOCK

Ref. No.	Parts No.	Description	Schematic No.	Ref. No.	Parts No.	Description	Schematic No.
KEY BOARD BLOCK				4-70x	ZS592378	Screw, Pan Head 2.6x3	
4-1	BK311346	Keyboard Block Comp. CS-703D		4-71x	BK305798	Keyboard Comp. (B) CN-2 (BL)	25-5-274
4-2	SK310913	Function Key (E)	CN-3031	4-72x	SK306098	Function Key (C) (BL)	CN-3031
4-3	SK310914	Function Key (F)	CN-3031	4-73x	SK306099	Function Key (D) (BL)	CN-3031
4-4	TC309641	Chassis (A) Part (P)-2	20-1-9	4-74	ZS608253	Screw, Pan Head 3x20	
4-5	TC282047	Brake Slide (B)	CN-1012	4-75	ZW550642	Washer (SPC) D3.1x8x0.5t	
4-6	ML282328	REC Lever	CN-1043	4-76x	ZW287458	Washer D3.3x6x0.3t	
4-7	ZS447840	Tapping Screw #2, 3x8 (BR)					
4-8	ES283151	Leaf SW. BSW-31 (PL)	25-10-25				
4-9	ZS537085	Screw, Binding Head 2x5					
4-10	MC310536	Counter ME360-003	9-1-68				
4-11x	ZS313267	Tapping Screw #2, 2.6x6 (Countersunk)					
4-12x	ZS200384	Screw, Countersunk Head 3x6					
4-13	BZ282881	Auto Stop Comp.	CN-3014				
4-14	MB283421	AS Belt	CN-1066				
4-15x	ZS432843	Screw, Pan Head 2.6x4					
4-16	ML305618	Eject Slide	CN-1302				
4-17	ZG385986	Safety Lever Return Spring	CS-2539				
4-18	ZG282126	Return Spring	CN-1022				
4-19	ZG282464	Return Spring (B)	CN-1065				
4-20	TC282137	REC Slide	CN-1023				
4-21	TC281788	RWD Slide Part CN	CN-1024				
4-22	ZW694798	Washer (Teflon) D3.1x7x0.2t					
4-23	TC282161	RWD Wheel	CN-1026				
4-24	ZW357164	'E' Ring 2.3M	6-1-9				
4-25	ZG282183	Spring	CN-1028				
4-26	ZW270088	'E' Ring 1.9M	6-1-9				
4-27	ZG282115	Brake Spring	CN-1021				
4-28	TC282262	Brake Slide (A)	CN-1037				
4-29	MB282104	Brake Rubber	CN-1020				
4-30	TC282194	F.F Slide	CN-1029				
4-31	ZG298350	Spring (B)	CN-1068				
4-32	BL282510	Middle Lever Part	CN-2023				
4-33	MB313845	Counter Belt	CN-1406				
4-34	MT305769	Take-up Reel Table (B) Part	13-2-49				
4-35	MT305793	Reel Cap	CF-2039				
4-36	ZG313829	Back Tension Spring	CN-1503				
4-37	ZW282420	Spring Spot Facing Washer	CN-1058				
4-38	MT-305770	Supply Reel Table (B) Part	13-2-50				
4-39	ZW381644	Washer (Polyslider) D2.1x4.0x0.13t					
4-40	BL282508	Take-up Lever Part	CN-2022				
4-41	ZG282431	REC Safety Spring	CN-1059				
4-42	ML282240	REC Safety Lever	CN-1035				
4-43	ML282273	Auto Stop Lever	CN-1038				
4-44x	ZS523664	Tapping Screw #2, 3x10 (BR)					
4-45	ZG606723	Spring T	KJ-2059				
4-46	ZW282407	Push Washer (B)	CN-1056				
4-47	ZG282251	Cassette Stopping Spring	CN-1036				
4-48x	ZW381644	Washer (Polyslider) D2.1x4x0.13t					
4-49	TC268468	Pause Slide Part CN	CN-1031				
4-50	TC282227	Scraper	CN-1033				
4-51	ZS374646	Screw, Pan Head 2x2					
4-52	ZG387178	Idler Tension Spring	CS-1106				
4-53	BZ280315	Mecha Chassis (B) Part-G	CN-1004				
4-54x	ZG303225	Tapping Screw #2, 3x10 (Bind)					
4-55x	ZS650013	Tapping Screw #1, 3x25 (BR)					
4-56	ZS417216	Screw, Pan Head 3x4					
4-57	ES283173	Leaf SW. BUW-31PLC	25-10-26				
4-58	EL301541	Lamp (Lead Type) 8V 55 MA	28-2-65				
4-59	TC515575	SW. Lock Cam (B)	CG-2301				
4-60	ZG632553	Button Lock Spring (C)	CG-2303				
4-61	TC282396	Cap	CN-1055				
4-62	MV357208	Steel Ball D2					
4-63	ZG282341	Head Return Spring	CN-1048				
4-64	ZG282352	Head Base Stopping Spring	CN-1049				
4-65	ZG300881	Head Retaining Spring (A)	CN-1070				
4-66	ZG300882	Head Retaining Spring (B)	CN-1070				
4-67	ZS201407	Screw, Pan Head 2.3x3					
4-68x	EP300424	Plunger 0730PHTI (JPN)	44-1-88				
4-69x	ZG310717	Plunger Spring	CY-1043				

When ordering parts, Please describe Parts Number, Description, and Model Number in detail.

5. P.C BOARDS

(1) PRE AMP P.C BOARD (CN-5501A) BLOCK

Symbol No.	Parts No.	Description	Schematic No.
(1)-1	BA311108	Pre Amp P.C Board Comp. CS-703D (U/T) (CSA, CEE, UK)	
(1)-2	BA311110	Pre Amp P.C Board Comp. CS-703D-J (JPN, AAL)	
(1)-IC1	E1605013	I.C. NE545B	45-8-117
(1)-TR1	ET603257	Transistor 2SC1312S(G)(H)	45-1-182
(1)-TR2	ET603257	Transistor 2SC1312S(G)(H)	45-1-182
(1)-TR3	ET639437	Transistor 2SC945L(Q)(P)	45-1-85
(1)-TR4	ET303697	FET 2SK117(GR)	45-12-15
(1)-TR5	ET399846	Transistor 2SC945L(Q)	45-1-85
(1)-TR6,7	ET639437	Transistor 2SC945L(Q)(P)	45-1-85
(1)-TR8	ET520266	Transistor 2SC1211(E)	45-1-96
(1)-TR9	ET310920	Transistor 2SC1846(R)(S)	45-1-267
(1)-D1,2	ED308953	Germanium Diode (Home. Type) 1K34A-LH	45-3-46
(1)-D3,4	ED308953	Germanium Diode (Home. Type) 1K34A-LH	45-3-46
(1)-D5	ED310607	Zener Diode HZ18-2	45-6-80
(1)-VR1	EV310606	Volume V16L4-N25KC-15A 50kA	36-6-36
(1)-VR2	EV305636	Semi-Fixed/Vol. D8 Axial Type 50 kB	36-10-273
(1)-VR3	EV305635	Semi-fixed/Vol. D8 Axial Type 5 kB	36-10-273
(1)-VR4	EV305637	Semi-Fixed/Vol. D8 Axial Type 10 kB	36-10-273
(1)-VR5	EV310610	Semi-Fixed/Vol. D8 Axial Type 300 kB	36-10-273
(1)-T1	EO283050	OSC. Coil 09A-1359	23-4-40
(1)-L1	EO310608	Ferri Inductor FE-001 3.3MH	23-1-304
(1)-FL1	ER309361	Dolby Filter D07-002	53-1-143
(1)-FL2	ER309119	Dolby Filter D07-001	53-1-143
(1)-FL3	EO310875	Trap Coil 7AAP-0316	23-1-296
(1)-J1	EJ313581	Mic Jack HLJ0335-01A	31-2-102
(1)-J2	EJ313580	Headphone Jack HLJ0305-01A	31-2-101
(1)-J3	EJ308985	4P Pin Jack (U/T, CSA, CEE, UK)	31-5-144
(1)-J3	EJ309366	4P Pin Jack X-Q3910#01 (JPN, AAL)	31-5-146
(1)-SW1	ES310591	Slide SW. 122074	25-3-164
(1)-SW2,3	ES310609	2 Throw Push SW. SUF22	25-5-313
(1)-SW4	ES283072	Slide SW. SSC22LP	25-3-131
(1)-C3	EC308990	Styrol/C. (Homing Type) 470PF(K) 50WV	24-11-14
(1)-C5	EC310599	Styrol/C. (Homing Type) 390PF(K) 50WV	24-11-14
(1)-C46	EC284163	Styrol/C. (w/Rubber) 1000PF(J) 250WV	24-11-13
(1)-3	ZW263946	Nylon Rivet 4x5	2-7-57
(1)-4	ZS325495	Tapping Screw #2, 3x6 (BR)	

(2) POWER SUPPLY P.C BOARD (CN-5502/5503/5504, CN-5303) BLOCK

Symbol No.	Parts No.	Description	Schematic No.
(2)-1	BA311158	Power Supply P.C Board Comp. CS-703D (U/T)	
(2)-2	BA311162	Power Supply P.C Board Comp. CS-703D-J	
(2)-3	BA311159	Power Supply P.C Board Comp. CS-703D(CSA)(AAL)	
(2)-4	BA311160	Power Supply P.C Board Comp. CS-703D (CEE)	
(2)-5	BA311161	Power Supply P.C Board Comp. CS-703D (BEAB)	
(2)-TR2	ET563905	Transistor 2SC711(G)(H)	45-1-67
(2)-TR3	ET398711	Transistor 2SC945L(Q)(R)	45-1-85
(2)-TR4	ET301154	Transistor 2SC1162(C)(D)	45-1-268
(2)-D1,2	ED306109	Silicon Diode W03B	45-2-78
(2)-D3	ED313846	Zener Diode HZ16-3	45-6-80
(2)-D4	ED306109	Silicon Diode W03B	45-2-78
(2)-SW1	ES309059	Δ Push SW. JP-27 (JPN, CSA, AAL)	25-5-285
(2)-SW1	ES310333	Δ Push SW. JP-28 (U/T, CEE, UK)	25-5-308
(2)-VS1	MZ283140	Δ Voltage Change 12M-60031	40-2-13
(2)-C3	EC242537	Elect./C. (Vert. Type) 1000μF 63WV (U/T, CSA, AAL, CEE, UK)	24-12-16
(2)-C3	EC295997	Elect./C. (Vert. Type) 2200μF 35WV (JPN)	24-12-9
(2)-C8	EC551160	Δ Ceramic/C. DB821 NA 0.01μF(Z) 1.4KWV	24-5-55
(2)-C8	EC294118	Δ Ceramic/C. DPN6600 YM 0.01μF(P) 125WV	24-5-70
(2)-C8	EC301320	Δ MP/C. 4700PF(M) 250WV	24-9-122
(2)-C9	EC301320	Δ MP/C. 4700PF(M) 250WV	24-9-122
(2)-C11	EC295997	Elect./C. (Vert. Type) 2200μF 35WV	24-12-9
(2)-6	ZS422076	Screw, Pan Head 3x5	

When ordering parts, Please describe Parts Number, Description, and Model Number in detail.

6. ILLUSTRATION OF FINAL ASSEMBLY BLOCK (1)

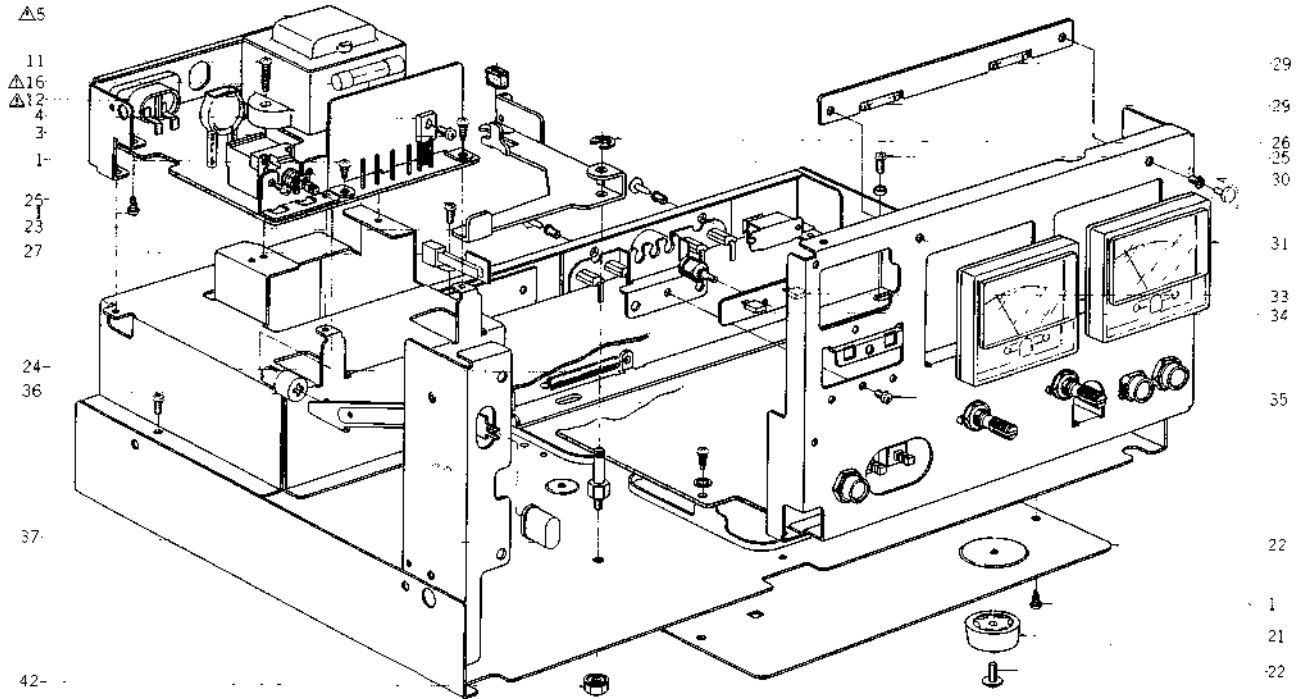

6. FINAL ASSEMBLY BLOCK (1)

Ref. No.	Parts No.	Description	Schematic No.	Ref. No.	Parts No.	Description	Schematic No.
6-1	ZS325495	Tapping Screw #2, 3x6 (BR)		6-21	SA306240	Rubber Foot (B)	LE-6740
6-2x	ZS447840	Tapping Screw #2, 3x8 (BR)		6-22	ZS306463	S-Tight Screw, 3x8 (Pan) w/Flange	
6-3	ZS379350	Screw, Pan Head 3x6		6-23	ML305628	REC Lever	CN-5312
6-4	ET307349	Transistor 2SD794 (P) (Q)	45-1-334	6-24	ZG305641	REC Spring	CN-5313
6-5	BT310566	△ Power Trans. CNT-31 (U/T)	38-4-679	6-25	ZS306021	S-Tight Screw, 3x6 (Pan)	
6-6x	BT310562	△ Power Trans. CNT-32 (JPN)	38-4-675	6-26	ZW290283	'U' Ring 2.85M	6-1-1
6-7x	BT310858	△ Power Trans. CNT-35 (CSA)	38-4-680	6-27	ES310460	Leaf SW. BSW-IFTX 3	25-10-37
6-8x	BT310563	△ Power Trans. CNT-34 (AAL)	38-4-676	6-28x	ZS200676	Tapping Screw #2, 3x6 (Countersunk)	
6-9x	BT310564	△ Power Trans. CNT-33 (CEE)	38-4-677	6-29	EL301541	Lamp (Lead Type) 8V 55 MA	28-2-65
6-10x	BT310565	△ Power Trans. CNT-36 (UK)	38-4-678	6-30	ZW260370	Nylon Rivet 3.4x5.5	2-7-56
6-11	ZS225134	Tapping Screw #2, 3x10 (PAN), w/washer (CEE, UK)		6-31	EM310600	VU Meter KL-289S-1	46-1-218
6-12	EJ310567	△ Inlet, Board Type (U/T, CEE, UK)	31-1-234	6-32x	EM312409	VU Meter MG-118S (BL)	46-1-221
6-13x	EZ631945	Strain Relief SR-4N-4 (JPN, CSA, AAL)	2-7-49	6-33	ED310584	LED GL-9PR2	45-15-21
6-14x	EW306427	△ AC Cord (JPN)	26-3-63	6-34	ED310585	LED GL-9PG2	45-15-22
6-15x	EW305691	△ AC Cord CUL (CSA, AAL)	26-3-65	6-35	ZS422076	Screw, Pan Head 3x5	
6-16	EF310229	△ Fuse 1A 125V	39-1-65	6-36	TC289484	SW. Joint	CN-6015
6-17x	EF309387	△ Fuse 1A 250V	39-1-64	6-37	SK305674	Power SW. Cap	CN-6338
6-18x	EF258344	△ Fuse (SEMKO T-type) 800MAT	39-1-53	6-38x	SK306130	Power SW. Cap (BL)	CN-6338
6-19x	EF258344	△ Fuse (SEMKO T-type) 800MAT	39-1-53	6-39x	ZS523664	Tapping Screw #2, 3x10(BR)	
6-20	SP310482	Bottom Plate	CN-5408	6-40x	ZS200384	Screw, Countersunk Head 3x6	
				6-41x	EW306152	△ AC Cord Set U/T Type 2	26-3-71
				6-42	ZW413267	Flange Nut M4	

When ordering parts, Please describe Parts Number, Description, and Model Number in detail.

7. ILLUSTRATION & PHOTO OF FINAL ASSEMBLY BLOCK (2)

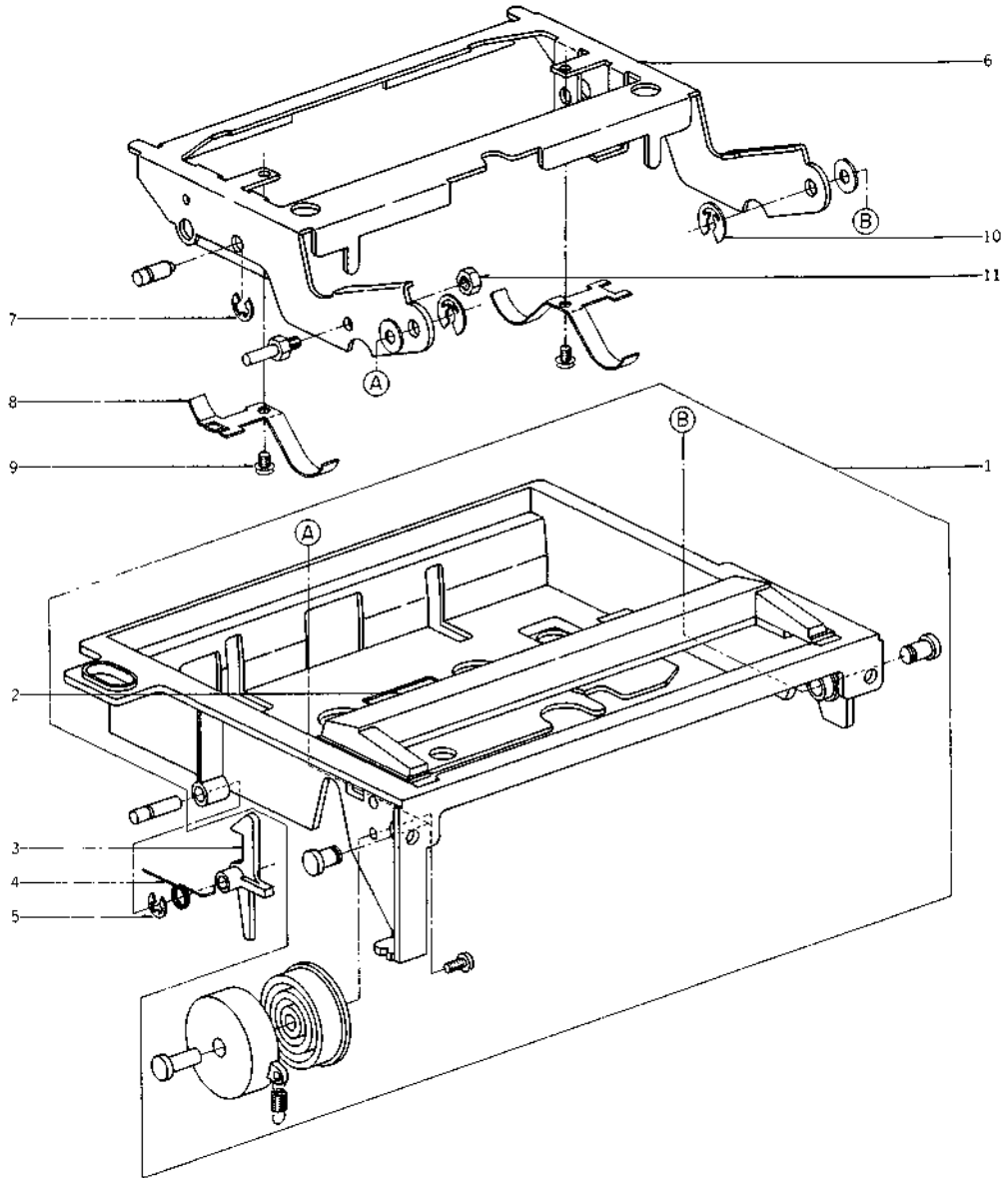

7) FINAL ASSEMBLY BLOCK (2)

Ref. No.	Parts No.	Description	
LID HOUSING BLOCK			
7-1	BZ311198	Lid Housing Assy GXC-704D	CN-6436
7-2	TC645186	Reflector	CA-2071
7-3	SZ310521	Lock Plate	CN-6422
7-4	ZG310519	Lock Spring	CN-6420
7-5	ZW270088	'E' Ring 1.9M	6-1-9
7-6	TC306770	Lid Frame (B)	CN-6358
7-7	ZW270101	'E' Ring 3M	6-1-9
7-8	ZG282690	Set Spring	CN-6009
7-9	ZS201407	Screw, Pan Head 2.3x3	
7-10	ZW290283	'U' Ring 2.85M	6-1-1
7-11	ZW273756	Nut M3, #1	
FRONT PANEL BLOCK			
7-12	BD311167	Front Panel Block Comp. CS-703D	
7-13x	BD311168	Front Panel Block Comp. CS-703D-BL (BL)	
7-14x	BD312072	Front Panel Block Comp. CS-703D-J (JPN)	
7-15	SE310625	Meter Escutcheon	CN-6503,6511
7-16x	SE310626	Meter Escutcheon (BL)	CN-6503,6511
7-17	SE310629	Button Escutcheon (A)	CN-6505
7-18x	SE310630	Button Escutcheon (A-BL) (Black)	CN-6505
7-19x	TC310515	Side Panel (L)	CN-6418
7-20x	TC310516	Side Panel (L-BL)	CN-6418
7-21	TC310517	Side Panel (R)	CN-6419
7-22x	TC310518	Side Panel (R-BL)	CN-6419
7-23	BD311171	Lid Panel Assy CS-703D	CN-6514
7-24x	BD311172	Lid Panel Assy CS-703D-BL	CN-6514
7-25x	TC310504	Lid Cover	CN-6410
7-26x	ZW260370	Nylon Rivet 3.4x5.5	2-7-56
FINAL ASSEMBLY BLOCK			
7-27	SK305653	Push Button (A)	CN-6309
7-28x	SK305656	Push Button (D) (BL)	CN-6309
7-29x	ZG305657	Button Spring	CN-6310
7-30x	ZS325495	Tapping Screw #2, 3x6 (BR)	
7-31x	ZS406416	Tapping Screw #2, 3x8 (Countersunk)	
7-32	SK310627	Vol. Knob	CN-6504
7-33x	SK310628	Vol. Knob (BL) (Black)	CN-6504
7-34x	SP310540	Back Board (B-9) (U) (U/T)	CN-6407,6507
7-35x	SP310478	Back Board (B-10) (J) (JPN)	CN-6407,6507
7-36x	SP310637	Back Board (B-6) (C) (CSA)	CN-6407,6509
7-37x	SP310635	Back Board (A-2) (A) (AAL)	CN-6405,6506
7-38x	SP310638	Back Board (B-7) (E) (CEE)	CN-6407,6508
7-39x	SP310639	Back Board (B-8) (B) (UK)	CN-6407,6508
7-40x	ZS462194	Tapping Screw #2, 3x8 (Pan) W=8	
7-41	BC310510	Upper Cover (B) (Except AAL)	CN-6414
7-42x	BC310509	Upper Cover (A) (AAL)	CN-6413
7-43	ZW548010	Spot Facing Washer	MU-6028
7-44	ZS306798	S-Tight Screw, 4x8 (Bind) (Black)	

8. ILLUSTRATION OF HEAD BLOCK

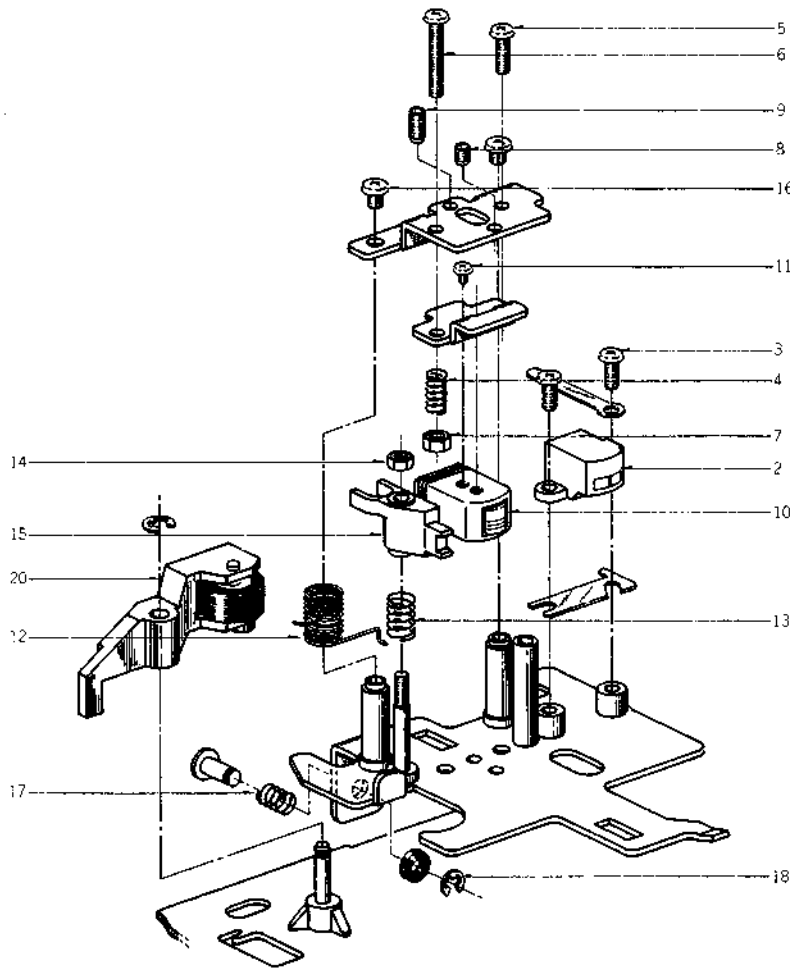

8) HEAD BLOCK

Ref. No.	Parts No.	Description	Schematic No.
8-1	BH311038	Head Block Comp. GXC-704D	
8-2	HE310582	Erase Head E-621-NM-0338	37-2-17
8-3	ZS375118	Screw, Binding Head 2.3x6	
8-4	ZG465636	Angle Adjust Spring	CG-0029
8-5	ZS391522	Screw, Pan Head 2.3x8	
8-6	ZS303625	Screw, Pan Head 2.3x16	
8-7	ZW273690	Nut #1 M2.3	
8-8	ZS356804	Set Screw, Hexagon Socket 3x4 (Cup/P.)	
8-9	ZS356815	Set Screw, Hexagon Socket 3x6 (Cup/P.)	
8-10	HP310933	REC/PB Head P4-360 Sigma	
8-11	ZS300626	Screw, Pan Head 2x2.5 (Camera Standard)	
8-12	ZG313866	Pinch Roller Spring	CN-0401
8-13	ZG269236	Tape Guide Spring	CM-0005
8-14	ZW273734	Nut #1 M2	
8-15	TC286007	Tape Guide (B)	CM-0002
8-16	ZS422076	Screw, Pan Head 3x5	
8-17	ZG310453	Clamp Spring	CN-0311
8-18	ZW270088	'E' Ring 1.9M	6-1-9
8-19x	ZS375107	Screw, Pan Head 2.6x4	
8-20	BL311391	Pinch Roller Block Comp. GXC-704D	

When ordering parts, Please describe Parts Number, Description, and Model Number in detail.

9. ILLUSTRATION OF MOTOR BLOCK

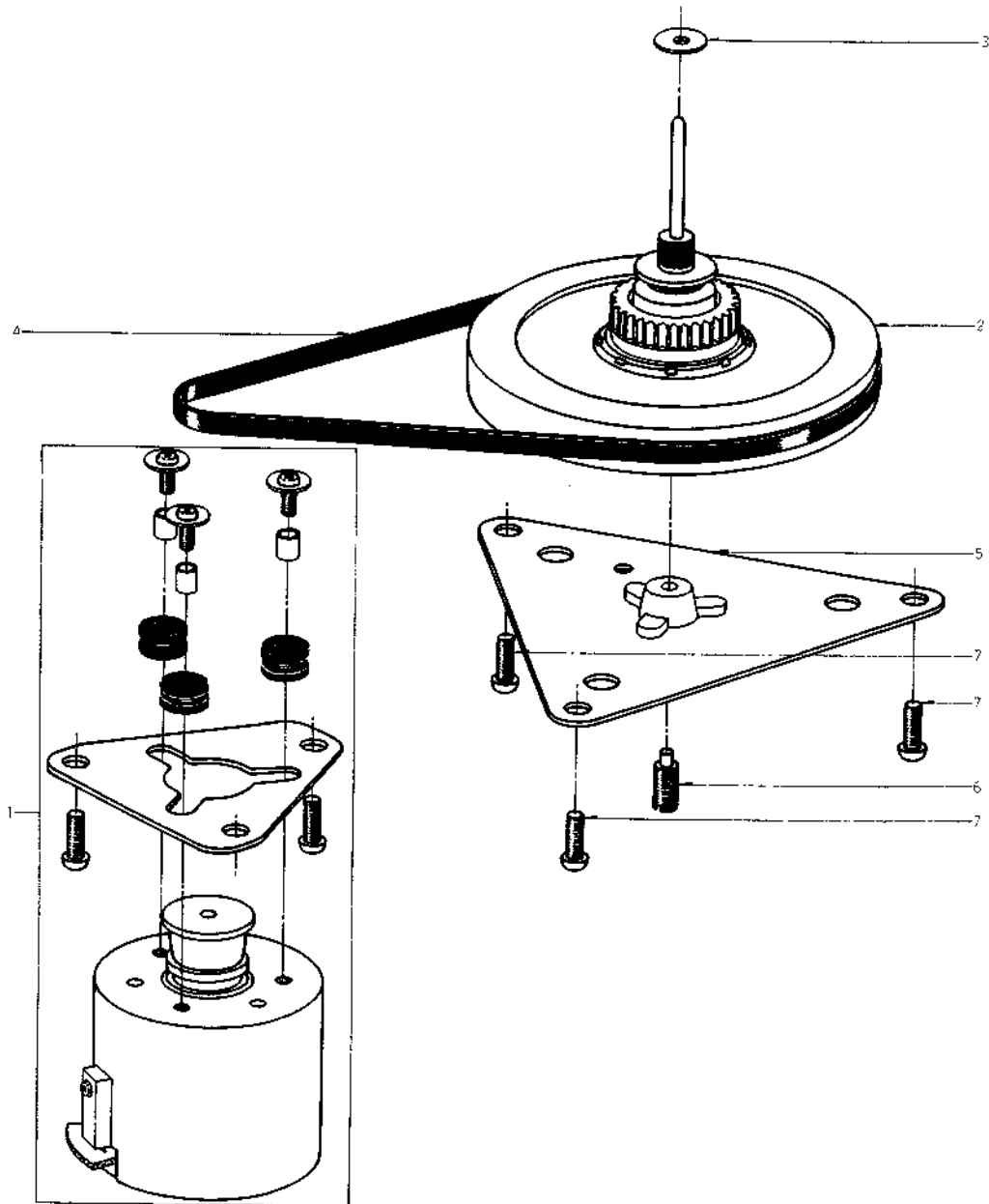

9) MOTOR BLOCK

Ref. No.	Parts No.	Description	Schematic No.
9-1	BM274230	Motor Block Comp. CN	
9-2	BF305887	Flywheel Part GXC-706D	
9-3	ZW282442	Thrust Washer	
9-4	MB282093	Capstan Belt	CN-1060
9-5	BZ280337	Flywheel Holder Plate Part	CN-1017
9-6	ZS297628	Adjust Screw	CN-1018
9-7	ZS447840	Tapping Screw #2, 3x8 (BR)	

When ordering parts, Please describe Parts Number, Description, and Model Number in detail.

10. ILLUSTRATION OF MECHA FRAME BLOCK

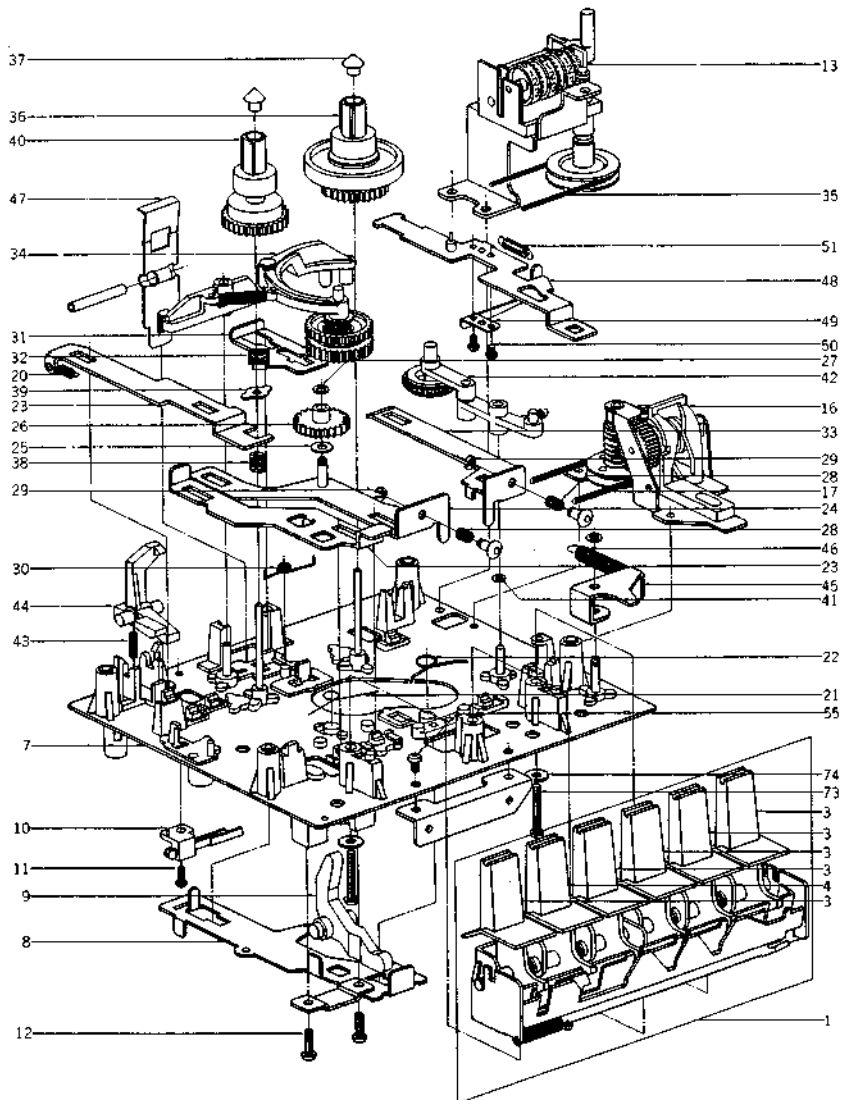
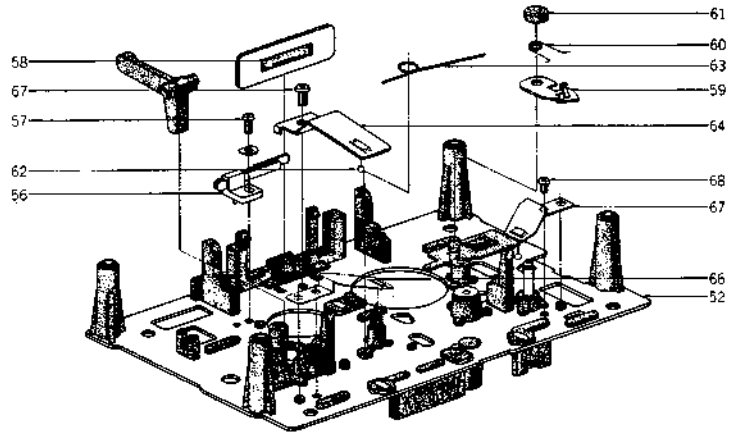

10) MECHA FRAME BLOCK

Ref. No.	Parts No.	Description	Schematic No.	Ref. No.	Parts No.	Description	Schematic No.
KEYBOARD BLOCK							
10-1	BK311328	Keyboard Block Comp. GXC-704D		10-68	ZS201407	Screw, Pan Head 2.3x3	
10-2x	BK311329	Keyboard Block Comp. GXC-704D-BL		10-69x	ZW357164	'E' Ring 2.3M	6-1-9
10-3	SK310469	Function Key (A)	CN-1408	10-70x	EP300424	Plunger 0730PHT1	44-1-88
10-4	SK310470	Function Key (B)	CN-1408	10-71x	ZG310717	Plunger Spring	CY-1043
10-5x	SK310471	Function Key (A-BL)	CN-1408	10-72x	ZS592378	Screw, Pan Head 2.6x3	
10-6x	SK310472	Function Key (B-BL)	CN-1408	10-73	ZS608253	Screw, Pan Head 3x20	
MECHA FRAME BLOCK				10-74	ZW550642	Washer (SPC) D3.1x8x0.5t	
10-7	TC309641	Chassis (A) Part (P)-2	20-1-9	10-75x	ZW287458	Washer D3.3x6x0.3t	
10-8	TC282047	Brake Slide (B)	CN-1012				
10-9	ML282328	REC Lever	CN-1043				
10-10	ES283151	Leaf SW. BSW-31 (PL)	25-10-25				
10-11	ZS537085	Screw, Binding Head 2x5					
10-12	ZS447840	Tapping Screw #2, 3x8 (BR)					
10-13	MC310536	Counter ME360-003	9-1-68				
10-14x	ZS313267	Tapping Screw #2, 2.6x6 (Countersunk)					
10-15x	ZS200384	Screw, Countersunk Head 3x6					
10-16	BZ282881	Auto Stop Comp.	CN-3014				
10-17	MB283421	AS Belt	CN-1066				
10-18x	ZS432843	Screw, Pan Head 2.6x4					
10-19	ML305618	Eject Slide	CN-1302				
10-20	ZG385936	Safety Lever Return Spring	CS-2539				
10-21	ZG282126	Return Spring	CN-1022				
10-22	ZG282464	Return Spring (B)	CN-1065				
10-23	TC282137	REC Slide	CN-1023				
10-24	TC281788	RWD Slide Part CN	CN-1024				
10-25	ZW694798	Washer (Teflon) D3.1x7x0.2t					
10-26	TC282161	RWD Wheel	CN-1026				
10-27	ZW282407	Push Washer (B)	CN-1056				
10-28	ZG282183	Spring	CN-1028				
10-29	ZW270088	'E' Ring 1.9M	6-1-9				
10-30	ZG282115	Brake Spring	CN-1021				
10-31	TC282262	Brake Slide (A)	CN-1037				
10-32	MB282104	Brake Rubber	CN-1020				
10-33	TC282194	F.F Slide	CN-1029				
10-34	BL282510	Middle Lever Part	CN-2023				
10-35	MB313845	Counter Belt	CN-1406				
10-36	MT305769	Take-up Reel Table (B) Part	13-2-49				
10-37	MT305793	Reel Cap	CF-2039				
10-38	ZG313829	Back Tension Spring	CN-1503				
10-39	ZW282420	Spring Spot Facing Washer	CN-1058				
10-40	MT305770	Supply Reel Table (B) Part	13-2-50				
10-41	ZW381644	Washer (Polyslider) D2.1x4.0x0.13t					
10-42	BL282508	Take-up Lever Part	CN-2022				
10-43	ZG282431	REC Safety Spring	CN-1059				
10-44	ML282240	REC Safety Lever	CN-1035				
10-45	ML282273	Auto Stop Lever	CN-1038				
10-46	ZG606723	Spring T	KJ-2059				
10-47	ZG282251	Cassette Stopping Spring	CN-1036				
10-48	TC268468	Pause Slide Part CN	CN-1031				
10-49	TC282227	Scraper	CN-1033				
10-50	ZS374646	Screw, Pan Head 2x2					
10-51	ZG387178	Idler Tension Spring	CS-1106				
10-52	BZ280315	Mecha Chassis (B) Part	CN-1004				
10-53x	ZG303225	Tapping Screw #2, 3x10(Bind)					
10-54x	ZS650013	Tapping Screw #1, 3x25 (BR)					
10-55	ZS417216	Screw, Pan Head 3x4					
10-56	ES283173	Leaf SW. BUW-31PLC	25-10-26				
10-57	ZS537085	Screw, Binding Head 2x5					
10-58	EL301541	Lamp (Lead Type) 8V 5MA	28-2-65				
10-59	TC515575	SW. Lock Cam (B)	CG-2301				
10-60	ZG632553	Button Lock Spring (C)	CG-2303				
10-61	TC282396	Cap	CN-1055				
10-62	MV357208	Steel Ball D2					
10-63	ZG282341	Head Return Spring	CN-1048				
10-64	ZG305620	Head Base Holder Spring	CN-1304				
10-65	ZS417216	Screw, Pan Head 3x4					
10-66	ZG300881	Head Retaining Spring (A)	CN-1070				
10-67	ZG300882	Head Retaining Spring (B)	CN-1070				

When ordering parts, Please describe Parts Number, Description, and Model Number in detail.

11. P.C BOARDS

(1) PRE AMP P.C BOARD (CN-5401A) BLOCK

Symbol No.	Parts No.	Description	Schematic No.
(1)-1	BA311056	Pre Amp P.C Board Comp. GXC-704D	
(1)-2	BA311057	Pre Amp P.C Board Comp. GXC-704D-J	
(1)-3	BA311379	Pre Amp P.C Board Comp. GXC-704D (AAL)	
(1)-IC1	EI605013	IC NE545B	45-8-117
(1)-IC2	EI306141	IC LA4170	45-8-305
(1)-TR1	ET603257	Transistor 2SC1312S(G)(H)	45-1-182
(1)-TR2	ET603257	Transistor 2SC1312S(G)(H)	45-1-182
(1)-TR3	ET303697	FET 2SK117 (GR)	45-12-15
(1)-TR4	ET399846	Transistor 2SC945L(Q)	45-1-85
(1)-TR5	ET639437	Transistor 2SC945L(Q)(P)	45-1-85
(1)-TR6,7	ET638504	Transistor 2SC945L(P)	45-1-85
(1)-TR8	ET639437	Transistor 2SC945L(Q)(P)	45-1-85
(1)-TR9	ET520266	Transistor 2SC1211(E)	45-1-95
(1)-TR10	ET301154	Transistor 2SC1162(C)(D)	45-1-268
(1)-D1	ED309341	Germanium Diode 1K34A	45-3-45
(1)-D2	ED624903	Silicon Diode 1S2473	45-3-28
(1)-D3toD6	ED309341	Germanium Diode 1K34A	45-3-45
(1)-D7	ED310607	Zener Diode HZ18-2	45-6-80
(1)-VR1	EV305635	Semi-Fixed/Vol. D8 Axial Type 5 k Ω	36-10-273
(1)-VR2	EV464220	Semi-Fixed/Vol. V8K4-1 50k(B)	36-10-266
(1)-VR3	EV305637	Semi-Fixed/Vol. D8 Axial Type 10 k Ω	36-10-273
(1)-VR4	EV550023	Semi-Fixed/Vol. V10K8-4-2 100k(B)	36-10-250
(1)-VR5	EV305637	Semi-Fixed/Vol. D8 Axial Type 10 k Ω	36-10-273
(1)-VR6	EV464207	Semi-Fixed/Vol. V8K4-1 5 k Ω	36-10-266
(1)-VR7	EV306989	Semi-Fixed/Vol. D8 Axial Type 1 k Ω	36-10-273
(1)-VR8	EV305635	Semi-Fixed/Vol. D8 Axial Type 5 k Ω	36-10-273
(1)-VR9	EV310571	Single Axial 2 Throw Vol. V16L4-15 10 k Ω x2	36-22-41
(1)-VR10	EV310572	Double Axial 2 Throw Vol. V16L4-15 50 k Ω x2	36-18-14
(1)-T1	EO283050	OSC. Coif 09A-1359	23-4-40
(1)-L1	EO310608	Ferri Inductor FE-001 3.3MH	23-1-304
(1)-FL1	ER309361	Dolby Filter D07-002	53-1-143
(1)-FL2	ER309119	Dolby Filter D07-001	53-1-143
(1)-FL3	EO310875	Trap Coif 7AAP-0316	23-1-296
(1)-J1	EJ313581	Mic Jack HLJ0335-01A	31-2-102
(1)-J2	EJ313580	Headphone Jack HLJ0305-01A	31-2-101
(1)-SW1	ES310591	Slide SW. 122074	25-3-164
(1)-SW2	ES310570	Rotary SW. SRZV084S	25-6-162
(1)-SW3	ES313579	Push SW. J-K2006#01	25-5-314
(1)-SW4	ES283072	Slide SW. SSC22LP(U/T)	25-3-131
(1)-R68	ER305722	Metal Oxide Film/R. (Homing Type) 2W 220 ohms (J)	35-11-22
(1)-C2	EC309416	Styrol/C. (Homing Type) 200PF(J) 50WV	24-11-14
(1)-C5	EC308990	Styrol/C. (Homing Type) 470PF(K) 50WV	24-11-14
(1)-C22	EC313826	Solid Aluminum/C. (Vert. Type) 0.1 μ F(K) 25WV	24-19-2
(1)-C23	EC313825	Solid Aluminum/C. (Vert. Type) 0.33 μ F(K) 25WV	24-19-2
(1)-C45	EC313825	Solid Aluminum/C. (Vert. Type) 0.22 μ F(K) 25WV	24-19-2

Symbol No.	Parts No.	Description	Schematic No.
(1)-C50	EC306438	Styrol/C. (Homing Type) 100PF(J) 50WV	24-11-14
(1)-C47	EC284163	Styrol/C. (w/Rubber) 1000PF(J) 250WV	24-11-13

(2) POWER SUPPLY P.C BOARD (CN-5502/5503/5504, CN-5303) BLOCK

Symbol No.	Parts No.	Description	Schematic No.
(2)-1	BA311067	Power Supply P.C Board Comp. GXC-704D (U/T)	
(2)-2	BA311071	Power Supply P.C Board Comp. GXC-704D-J	
(2)-3	BA311068	Power Supply P.C Board Comp. GXC-704D (CSA)	
(2)-4	BA311069	Power Supply P.C Board Comp. GXC-704D (CEE)	
(2)-5	BA311070	Power Supply P.C Board Comp. GXC-704D(BEAB)	
(2)-TR1	ET307349	Transistor 2SD794(P)(Q)	45-1-334
(2)-TR2	ET563905	Transistor 2SC711(G)(H) (JPN)	45-1-67
(2)-TR3	ET399846	Transistor 2SC945L(Q) (JPN)	45-1-85
(2)-TR4	ET301154	Transistor 2SC1162(C)(D) (JPN)	45-1-268
(2)-D1,2	ED306109	Silicon Diode W03B	45-2-78
(2)-D3	ED310578	Zener Diode WZ-177	45-6-67
(2)-D4	ED306109	Silicon Diode W03B(JPN)	45-2-78
(2)-J1	EJ310567	Δ Inlet, Board Type	31-1-234
(2)-SW1	ES310333	Δ Push SW. JP-28 (U/T, CEE, UK)	25-5-308
(2)-SW1	ES309059	Δ Push SW. JP-27 (JPN, CSA, AAL)	25-5-285
(2)-VS1	MZ283140	Δ Voltage Changer 12M-60031 (U/T)	40-2-13
(2)-C3	EC432652	Elect./C. (Vert. Type) 1000 μ F 35WV	24-12-9
(2)-C10	EC295997	Elect./C. (Vert. Type) 2200 μ F 35WV (JPN)	24-12-9
(2)-C11	EC551160	Δ Ceramic/C. DB821 NA 0.01 μ F(Z) 1.4WV (U/T, JPN)	24-5-55
(2)-C11	EC294118	Δ Ceramic/C. DPN6600 YM 0.01 μ F(P) 125WV (CSA, AAL)	24-5-70
(2)-C11	EC301320	Δ MP/C. 4700PF(M) 250WV (CEE, UK)	24-9-122
(2)-C12	EC301320	Δ MP/C. 4700PF(M) 250WV (UK)	24-9-122
(2)-6	ZS422076	Screw, Pan Head 3x5	
(2)-7	ZS447840	Tapping Screw #2, 3x8 (BR)	
(2)-8	ZS379350	Screw, Pan Head 3x6	

When ordering parts, Please describe Parts Number, Description, and Model Number in detail.

12. ILLUSTRATION OF AMP CHASSIS BLOCK

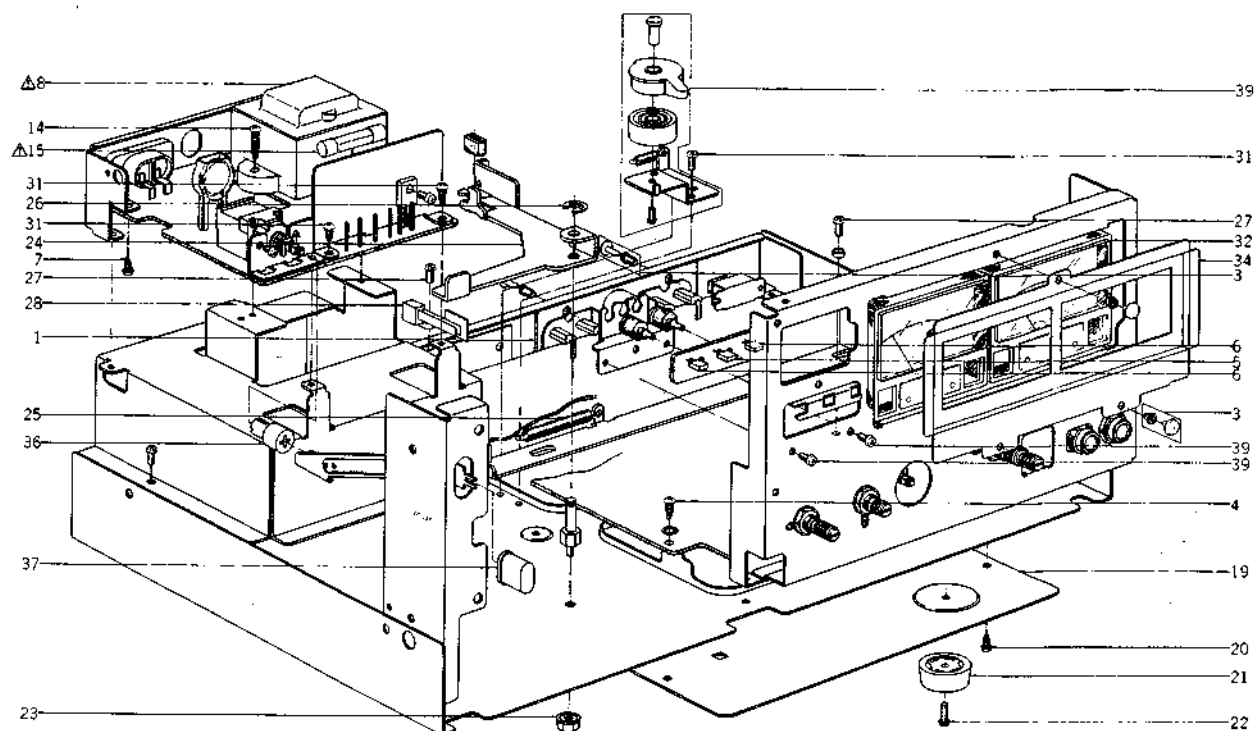

12) AMP CHASSIS BLOCK

Ref. No.	Parts No.	Description	Schematic No.	Ref. No.	Parts No.	Description	Schematic No.
PRE AMP BLOCK				AMP CHASSIS BLOCK			
12-1	EJ283094	4P Pin Jack 1-01-0107-01	31-5-137	12-19	SP310482	Bottom Plate	CN-5408
12-2x	EJ309366	4P Pin Jack X-Q3910#01(JPN)	31-5-146	12-20	ZS325495	Tapping Screw #2, 3x6 (BR)	
12-3	ZW263946	Nylon Rivet 4x5	2-7-57	12-21	SA306240	Rubber Foot (B)	LE-6740
12-4	ZS325495	Tapping Screw #2, 3x6 (BR)		12-22	ZS306463	S-Tight Screw, 3x8 (Pan) w/Flange	
LED P.C BOARD BLOCK				12-23	ZW413267	Flange Nut M4	
12-5	ED310585	LED GL-9PG2	45-15-22	12-24	ML305628	REC Lever	CN-5312
12-6	ED310584	LED GL-9PR2	45-15-21	12-25	ZG305641	REC Spring	CN-5313
POWER SUPPLY BLOCK				12-26	ZW290283	'U' Ring 2.85M	6-1-1
12-7	ZS447840	Tapping Screw #2, 3x8 (BR)		12-27	ZS306021	S Tight Screw, 3x6 (PAN)	
12-8	BT313831	Δ Power Trans. CNT-41(U/T)	38-4-710	12-28	ES301747	Leaf SW. BSW-1F TX-2	25-10-30
12-9x	BT313832	Δ Power Trans. CNT-42 (JPN)	38-4-711	12-29x	ZS200676	Tapping Screw #2, 3x6 (Countersunk)	
12-10x	BT313834	Δ Power Trans. CNT-45 (CSA)	38-4-713	12-30	ZS379350	Screw, Pan Head 3x6	
12-11x	BT310858	Δ Power Trans. CNT-44 (AAL)	38-4-712	12-31	ZS306021	S-Tight Screw, 3x6 (Pan)	
12-12x	BT310564	Δ Power Trans. CNT-33 (CEE)	38-4-677	12-32	EM305634	VU Meter S11ADR68B	46-1-187
12-13x	BT310565	Δ Power Trans. CNT-36 (UK)	38-4-678	12-33x	EM306132	VU Meter S11 ADR68C (BL)	46-1-193
12-14	ZS225134	Tapping Screw #2, 3x10 (Pan), w/washer		12-34	SP310487	Meter Panel	CN-5413
12-15	EF310229	Δ Fuse 1A 125V	39-1-65	12-35x	SP310488	Meter Panel (BL)	CN-5413
12-16x	EF309387	Δ Fuse 1A 250V	39-1-64	12-36	TC289484	SW. Joint	2-9-187,CM-6015
12-17x	EF258344	Δ Fuse (SEMKO T-type) 800MAT	39-1-53	12-37	SK305674	Power SW. Cap	CN-6338
12-18x	EF258344	Δ Fuse (SEMKO T-type) 800MAT	39-1-53	12-38x	SK306130	Power SW. Cap	CN-6338
				12-39	TC311075	Oil Clutch Assy GXC-704D	CN-5419

When ordering parts, Please describe Parts Number, Description, and Model Number in detail.

13. ILLUSTRATION & PHOTO OF FINAL ASSEMBLY BLOCK

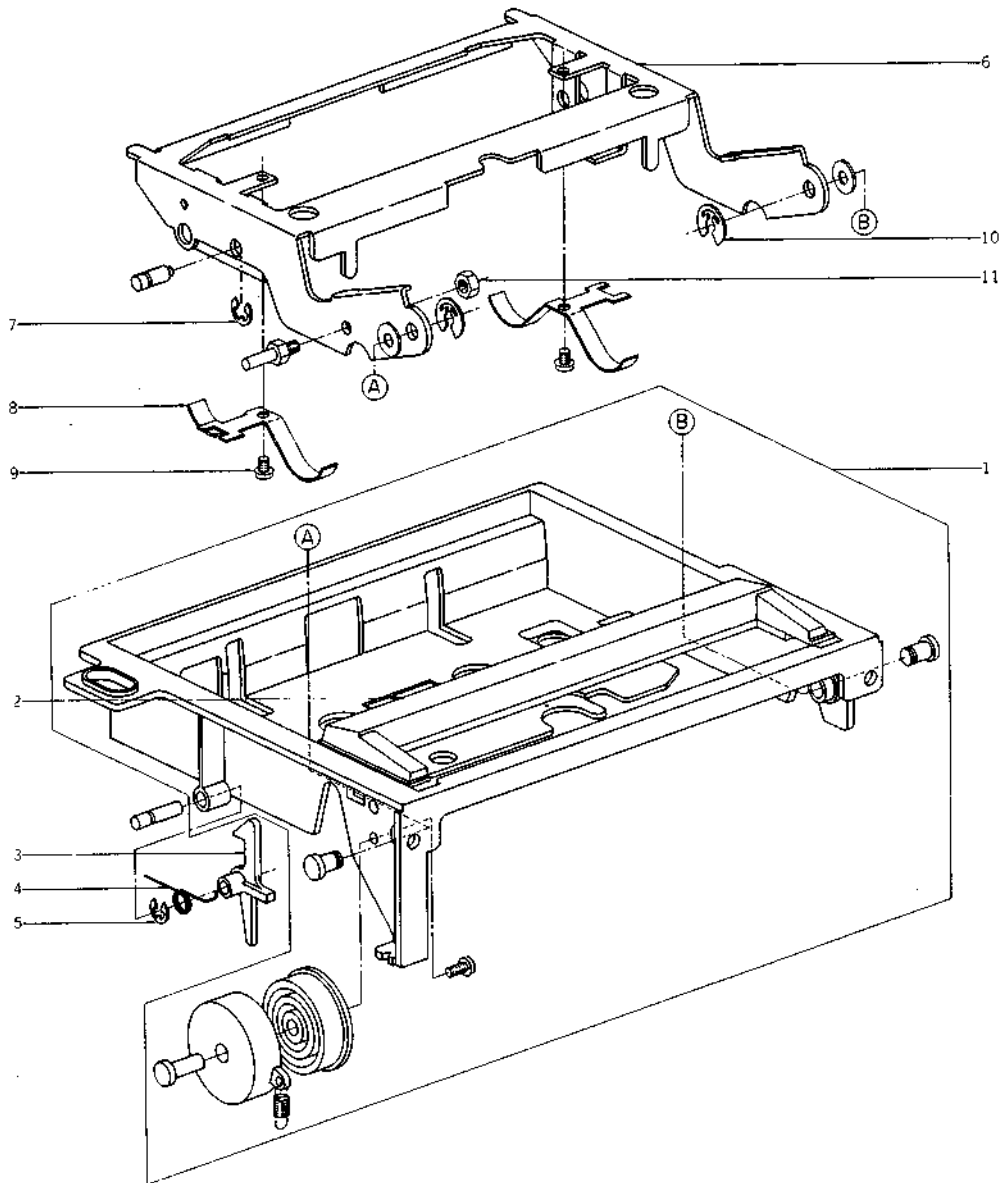

13) FINAL ASSEMBLY BLOCK

Ref. No.	Parts No.	Description	Schematic No.
LID HOUSING BLOCK			
13-1	BZ311198	Lid Housing Assy GXC-704D	CN-6436
13-2	TC645186	Reflector	CA-2071
13-3	SZ310521	Lock Plate	CN-6422
13-4	ZG310519	Lock Spring	CN-6420
13-5	ZW270088	'E' Ring 1.9M	6-1-9
13-6	TC306770	Lid Frame (B)	CN-6358
13-7	ZW270101	'E' Ring 3M	6-1-9
13-8	ZG282690	Set Spring	CN-6009
13-9	ZS201407	Screw, Pan Head 2.3x3	
13-10	ZW290283	'U' Ring 2.85M	6-1-1
13-11	ZW273756	Nut M3, #1	

Ref. No.	Parts No.	Description	Schematic No.
FRONT PANEL BLOCK			
13-12	BD311028	Front Panel Block Comp. GXC-704D (U/T, CSA, AAL, CEE, UK)	
13-13x	BD312177	Front Panel Block Comp. GXC-704D-J (JPN)	
13-14x	BD311029	Front Panel Block Comp. GXC-704D-BL (BL)	
13-15	SE310512	Meter Escutcheon	CN-6416,6435
13-16x	SE310513	Meter Escutcheon (BL)	CN-6416,6435
13-17	SZ310514	Meter Plate	CN-6417
13-18	SE310631	Button Escutcheon (B)	CN-6505
13-19x	SE310632	Button Escutcheon (B-BL)	CN-6505
13-20	SK305653	Push Button (A)	CN-6309
13-21x	SK305656	Push Button (D) (BL)	CN-6309
13-22x	ZG305657	Button Spring	CN-6310
13-23	TC310517	Side Mold (R)	CN-6419
13-24x	TC310518	Side Mold (R-BL)	CN-6419
13-25x	TC310515	Side Mold (L)	CN-6418
13-26x	TC310516	Side Mold (L-BL)	CN-6418
13-27	BD311033	Lid Panel Assy GXC-704D	CN-5424
13-28x	TC310504	Lid Cover	CN-6410
13-29x	ZW260370	Nylon Rivet 3.4x5.5	2-7-56
13-30	SE310525	Keyboard Escutcheon	CN-6426,6427
13-31x	SE310526	Keyboard Escutcheon (BL)	CN-6426,6427

Ref. No.	Parts No.	Description	Schematic No.
FINAL ASSEMBLY BLOCK			
13-32x	ZS325495	Tapping Screw #2, 3x6 (BR)	
13-33x	ZS200676	Tapping Screw #2, 3x6 (Countersunk)	
13-34x	ZS200384	Screw, Countersunk Head 3x6	
13-35x	ZS523664	Tapping Screw #2, 3x10 (BR)	
13-36x	ZW302909	Nylon Rivet (FNPR) 3x3.5 (Black)	
13-37x	ZS406416	Tapping Screw #2, 3x8 (Countersunk)	
13-38	SK311988	Double Knob (Upper) Part GXC-704D	CN-6429
13-39x	SK311989	Double Knob (Upper-BL) Part GXC-704D-BL	CN-6429
13-40	SK311990	Double Knob (Lower) Part GXC-704D	CN-6431
13-41x	SK311991	Double Knob (Lower-BL) Part GXC-704D-BL	CN-6431
13-42	SK310494	Knob (A)	CN-6401
13-43x	SK310495	Knob (A-BL)	CN-6401
13-44	SK310527	Knob (B)	CN-6428
13-45x	SK310528	Knob (B-BL) (BLACK)	CN-6428
13-46x	SP310636	Back Board (B-5) (U) (U/T)	CN-6407,6439
13-47x	SP310500	Back Board (B-1) (J) (JPN)	CN-6407,6408
13-48x	SP310501	Back Board (B-2) (C) (CSA)	CN-6407,6408
13-49x	SP310499	Back Board (A-1) (A) (AAL)	CN-6405,6406
13-50x	SP310502	Back Board (B-3) (E) (CEE)	CN-6407,6409
13-51x	SP310503	Back Board (B-4) (B) (UK)	CN-6407,6409
13-52x	ZS462194	Tapping Screw #2, 3x8 (Pan) W=8	
13-53	BC310510	Upper Cover (B) (BLACK)	CN-6414
13-54x	BC310509	Upper Cover (A) (AAL)	CN-6413
13-55	ZS306798	S-Tight Screw, 4x8 (Bind) (Black)	
13-56	ZW548010	Spot Facing Washer	MU-6028

Ref. No.	Parts No.	Description	Schematic No.
13-57x	EZ631945	Strain Relief SR-4N-4 (JPN, CSA, AAL)	2-7-49
13-58x	EW306152	△ AC Cord Set U/T Type 2 (U/T)	26-3-71
13-59x	EW306427	△ AC Cord (JPN)	26-3-63
13-60x	EW305691	△ AC Cord CUL (CSA, AAL)	26-3-65

When ordering parts, Please describe Parts Number, Description, and Model Number in detail.

14. LIST OF INTERCHANGEABLE SEMICONDUCTORS

If, while servicing, the original parts cannot be obtained, the interchangeable parts listed below can be substituted.

Original Parts			Interchangeable Parts	
Description	Parts No.	Utilizing P.C Board	Description	Parts No.
2SC945L (P) 2SC945L (Q) (P)	ET638504 ET639437	CN-5501A CN-5301A	2SC2130 (F) (G)	ET311868
2SC1211 (E)	ET520266	CN-5501A CN-5401A	2SC1214 (C) (D)	ET302495
2SC1162 (C) (D)	ET301154	CN-5401A	2SC1846 (R) (S) 2SD794 (P) (Q) 2SD360 (D) (E)	ET310920 ET307349 ET517375
2SD794 (P) (Q)	ET307349	CN-5504	2SC1162 (C) (D) 2SD360 (D) (E)	ET301154 ET517375
1K34A 1K34A-LH	ED309341 ED308953	CN-5501A CN-5401A	1N34A	ED219464

Chart-6

INDEX

Parts No.	Ref. No. & Symbol No.	Parts No.	Ref. No. & Symbol No.	Parts No.	Ref. No. & Symbol No.	Parts No.	Ref. No. & Symbol No.	Parts No.	Ref. No. & Symbol No.
BA311056	(1)-1	EC310599	(1)-C5	ET520266	(1)-TR9	TC282262	4-28	SZ310514	13-17
BA311057	(1)-2	EC313825	(1)-C23	ET563905	(2)-TR2	TC282262	10-31	SZ310521	7-3
BA311067	(2)-1	EC313825	(1)-C39	ET603257	(1)-TR1	TC282396	4-61	SZ310521	13-3
BA311068	(2)-3	EC313826	(1)-C22	ET603257	(1)-TR2	TC282396	10-61	ZG282036	2-6
BA311069	(2)-4	EC432652	(2)-C3	ET638504	(1)-TR6,7	TC286007	8-15	ZG282115	4-27
BA311070	(2)-5	EC551160	(2)-C8	ET639437	(1)-TR3	TC289484	6-36	ZG282115	10-30
BA311071	(2)-2	EC551160	(2)-C11	ET639437	(1)-TR5	TC289484	12-36	ZG282126	4-18
BA311108	(1)-1	ED306109	(2)-D1,2	ET639437	(1)-TR6,7	TC306770	7-6	ZG282126	10-21
BA311110	(1)-2	ED306109	(2)-D4	ET639437	(1)-TR8	TC306770	13-6	ZG282183	4-25
BA311158	(2)-1	ED308953	(1)-D1,2	EV305635	(1)-VR1	TC309641	4-4	ZG282183	10-28
BA311159	(2)-3	ED308953	(1)-D3,4	EV305635	(1)-VR3	TC309641	10-7	ZG282251	4-47
BA311160	(2)-4	ED309341	(1)-D1	EV305635	(1)-VR8	TC310504	7-25x	ZG282251	10-47
BA311161	(2)-5	ED309341	(1)-D3toD6	EV305636	(1)-VR2	TC310504	13-28x	ZG282341	4-63
BA311162	(2)-2	ED310578	(2)-D3	EV305637	(1)-VR3	TC310515	7-19x	ZG282341	10-63
BA311379	(1)-3	ED310584	6-33	EV305637	(1)-VR4	TC310515	13-25x	ZG282352	4-64
BC310509	7-42x	ED310584	12-6	EV305637	(1)-VR5	TC310516	7-20x	ZG282374	2-20
BC310509	13-54x	ED310585	6-34	EV306989	(1)-VR7	TC310516	13-26x	ZG282431	4-41
BC310510	7-41	ED310585	12-5	EV310571	(1)-VR9	TC310517	7-21	ZG282431	10-43
BC310510	13-53	ED310607	(1)-D5	EV310572	(1)-VR10	TC310517	13-23	ZG282464	4-19
BD311028	13-12	ED310607	(1)-D7	EV310606	(1)-VR1	TC310518	7-22x	ZG282464	10-22
BD311029	13-14x	ED313846	(2)-D3	EV310610	(1)-VR5	TC310518	13-24x	ZG282690	7-8
BD311033	13-27	ED624903	(1)-D2	EV464207	(1)-VR6	TC311075	12-39	ZG282690	13-8
BD311167	7-12	EF258344	6-18x	EV464220	(1)-VR2	TC515575	4-59	ZG289236	8-13
BD311168	7-13x	EF258344	6-19x	EV550023	(1)-VR4	TC515575	10-59	ZG298350	2-17
BD311171	7-23	EF258344	12-17x	EW305691	6-15x	TC645186	7-2	ZG298350	4-31
BD311172	7-24x	EF258344	12-18x	EW305691	13-60x	TC645186	13-2	ZG300881	4-65
BD312072	7-14x	EF309387	6-17x	EW306152	6-41x	SA306240	6-21	ZG300881	10-66
BD312177	13-13x	EF309387	12-16x	EW306152	13-58x	SA306240	12-21	ZG300882	4-66
BF305887	3-2	EF310229	6-16	EW306427	6-14x	SE310512	13-15	ZG300882	10-67
BF305887	9-2	EF310229	12-15	EW306427	13-59x	SE310513	13-16x	ZG303225	4-54x
BH311038	8-1	EI306141	(1)-IC2	EZ631945	6-13x	SE310525	13-30	ZG303225	10-53x
BH312065	2-1x	EI605013	(1)-IC1	EZ631945	13-57x	SE310526	13-31x	ZG305620	10-64
BK305798	4-71x	EJ283094	12-1	HE310582	2-4	SE310625	7-15	ZG305641	6-24
BK311328	10-1	EJ308955	(1)-J3	HE310582	8-2	SE310626	7-16x	ZG305641	12-25
BK311329	10-2x	EJ309366	(1)-J3	HP310602	2-7	SE310629	7-17	ZG305657	7-29x
BK311346	4-1	EJ309366	12-2x	HP310933	8-10	SE310630	7-18x	ZG305657	13-22x
BL282508	4-40	EJ310567	(2)-J1	MB282093	3-4	SE310631	13-18	ZG310453	8-17
BL282508	10-42	EJ310567	6-12	MB282093	9-4	SE310632	13-19x	ZG310519	7-4
BL282510	4-32	EJ313580	(1)-J2	MB282104	4-29	SK305653	7-27	ZG310519	13-4
BL282510	10-34	EJ313581	(1)-J1	MB282104	10-32	SK305653	13-20	ZG310717	4-69x
BL300249	2-19	EL301541	4-58	MB283421	4-14	SK305656	7-28x	ZG310717	10-71x
BL311391	8-20	EL301541	6-29	MB283421	10-17	SK305656	13-21x	ZG313829	4-36
BM274230	3-1	EL301541	10-58	MB313845	4-33	SK305674	6-37	ZG313829	10-38
BM274230	9-1	EM305634	12-32	MB313845	10-35	SK305674	12-37	ZG313866	8-12
BT310562	6-6x	EM306132	12-33x	MC310536	4-10	SK306098	4-72x	ZG385986	4-17
BT310563	6-8x	EM310600	6-31	MC310536	10-13	SK306099	4-73x	ZG385986	10-20
BT310564	6-9x	EM312409	6-32x	ML282240	4-42	SK306130	6-38x	ZG387178	4-52
BT310564	12-12x	EO283050	(1)-T1	ML282240	10-44	SK306130	12-38x	ZG387178	10-51
BT310565	6-10x	EO310608	(1)-L1	ML282273	4-43	SK310469	10-3	ZG465636	8-4
BT310565	12-13x	EO310875	(1)-FL3	ML282273	10-45	SK310470	10-4	ZG606723	4-45
BT310566	6-5	EP300424	4-68x	ML282328	4-6	SK310471	10-5x	ZG606723	10-46
BT310858	6-7x	EP300424	10-70x	ML282328	10-9	SK310472	10-6x	ZG632553	4-60
BT313831	12-8	ER305722	(1)-R68	ML305618	4-16	SK310494	13-42	ZG632553	10-60
BT313832	12-9x	ER309119	(1)-FL2	ML305618	10-19	SK310495	13-43x	ZS200384	4-12x
BT313833	12-11x	ER309361	(1)-FL1	ML305628	6-23	SK310527	13-44	ZS200384	6-40x
BT313834	12-10x	ES283072	(1)-SW4	ML305628	12-24	SK310528	13-45x	ZS200384	10-15x
BZ280315	4-53	ES283151	4-8	MT305769	4-34	SK310627	7-32	ZS200384	13-34x
BZ280315	10-52	ES283151	10-10	MT305769	10-36	SK310628	7-33x	ZS200676	6-28x
BZ280337	3-5	ES283173	4-57	MT305770	4-38	SK310913	4-2	ZS200676	12-29x
BZ280337	9-5	ES283173	10-56	MT305770	10-40	SK310914	4-3	ZS200676	13-33x
BZ282881	4-13	ES301747	12-28	MT305793	4-35	SK311988	13-38	ZS201407	4-67
BZ282881	10-16	ES309059	(2)-SW1	MT305793	10-37	SK311989	13-39x	ZS201407	7-9
BZ311198	7-1	ES310333	(2)-SW1	MV357208	4-62	SK311990	13-40	ZS201407	10-68
BZ311198	13-1	ES310460	6-27	MV357208	10-62	SK311991	13-41x	ZS201407	13-9
EC242537	(2)-C3	ES310570	(1)-SW2	MZ283140	(2)-VS1	SP310478	7-35x	ZS225134	6-11
EC284163	(1)-C46	ES310591	(1)-SW1	TC268468	4-49	SP310482	6-20	ZS225134	12-14
EC284163	(1)-C51	ES310609	(1)-SW2,3	TC268468	10-48	SP310482	12-19	ZS297628	3-6
EC294118	(2)-C8	ES313579	(1)-SW3	TC281788	4-21	SP310487	12-34	ZS297628	9-6
EC294118	(2)-C11	ET301154	(1)-TR10	TC281788	10-24	SP310488	12-35x	ZS300436	2-5
EC295997	(2)-C3	ET301154	(2)-TR4	TC282025	2-2	SP310499	13-49x	ZS300626	8-11
EC295997	(2)-C10	ET303697	(1)-TR3	TC282047	4-5	SP310500	13-47x	ZS303625	8-6
EC295997	(2)-C11	ET303697	(1)-TR4	TC282047	10-8	SP310501	13-48x	ZS306021	6-25
EC301320	(2)-C8	ET307349	(2)-TR1	TC282137	4-20	SP310502	13-50x	ZS306021	12-27
EC301320	(2)-C9	ET307349	6-4	TC282137	10-23	SP310503	13-51x	ZS306021	12-31
EC301320	(2)-C11	ET310920	(1)-TR9	TC282161	4-23	SP310540	7-34x	ZS306126	2-16
EC301320	(2)-C12	ET398711	(2)-TR3	TC282161	10-26	SP310635	7-37x	ZS306463	6-22
EC306438	(1)-C50	ET399846	(1)-TR4	TC282194	4-30	SP310636	13-46x	ZS306463	12-22
EC308990	(1)-C3	ET399846	(1)-TR5	TC282194	10-33	SP310637	7-36x	ZS306798	7-44
EC308990	(1)-C5	ET399846	(2)-TR3	TC282227	4-50	SP310638	7-38x	ZS306798	13-55
EC309416	(1)-C2	ET520266	(1)-TR8	TC282227	10-49	SP310639	7-39x	ZS313267	4-11x

INDEX

Parts No.	Ref. No. & Symbol No.	Parts No.	Ref. No. & Symbol No.	Parts No.	Ref. No. & Symbol No.	Parts No.	Ref. No. & Symbol No.	Parts No.	Ref. No. & Symbol No.
ZS313267	10-14x	ZW290283	13-10						
ZS325495	(1)-4	ZW300883	2-11						
ZS325495	6-1	ZW300884	2-12x						
ZS325495	7-30x	ZW300885	2-13x						
ZS325495	12-4	ZW300886	2-14x						
ZS325495	12-20	ZW300887	2-15x						
ZS325495	13-32x	ZW302909	13-36x						
ZS356804	8-8	ZW305492	2-9						
ZS356815	8-9	ZW357164	4-24						
ZS374646	4-51	ZW357164	10-69x						
ZS374646	10-50	ZW381644	4-39						
ZS375107	8-19x	ZW381644	4-48x						
ZS375118	8-3	ZW381644	10-41						
ZS379350	(2)-8	ZW413267	6-42						
ZS379350	6-3	ZW413267	12-23						
ZS379350	12-30	ZW548010	7-43						
ZS391522	8-5	ZW548010	13-56						
ZS406416	7-31x	ZW550642	4-75						
ZS406416	13-37x	ZW550642	10-74						
ZS417216	4-56	ZW694798	4-22						
ZS417216	10-55	ZW694798	10-25						
ZS417216	10-65								
ZS422076	(2)-6								
ZS422076	6-35								
ZS422076	8-16								
ZS432843	4-15x								
ZS432843	10-18x								
ZS432674	2-3								
ZS447840	3-7								
ZS447840	4-7								
ZS447840	(2)-7								
ZS447840	6-2x								
ZS447840	9-7								
ZS447840	10-12								
ZS447840	12-7								
ZS462194	7-40x								
ZS462194	13-52x								
ZS522180	2-10								
ZS523664	4-44x								
ZS523664	6-39x								
ZS523664	13-35x								
ZS537085	4-9								
ZS537085	10-11								
ZS537085	10-57								
ZS592378	4-70x								
ZS592378	10-72x								
ZS608253	4-74								
ZS608253	10-73								
ZS650013	4-55x								
ZS650013	10-54x								
ZW260370	6-30								
ZW260370	7-26x								
ZW260370	13-29x								
ZW263946	(1)-3								
ZW263946	12-3								
ZW270088	2-18								
ZW270088	4-26								
ZW270088	7-5								
ZW270088	8-18								
ZW270088	10-29								
ZW270088	13-5								
ZW270101	7-7								
ZW270101	13-7								
ZW273690	8-7								
ZW273734	2-8								
ZW273734	8-14								
ZW273756	7-11								
ZW273756	13-11								
ZW282407	2-21								
ZW282407	4-46								
ZW282407	10-27								
ZW282420	4-37								
ZW282420	10-39								
ZW282442	3-3								
ZW282442	9-3								
ZW287458	4-76x								
ZW287458	10-75x								
ZW290283	6-26								
ZW290283	7-10								
ZW290283	12-26								

IC NE545B

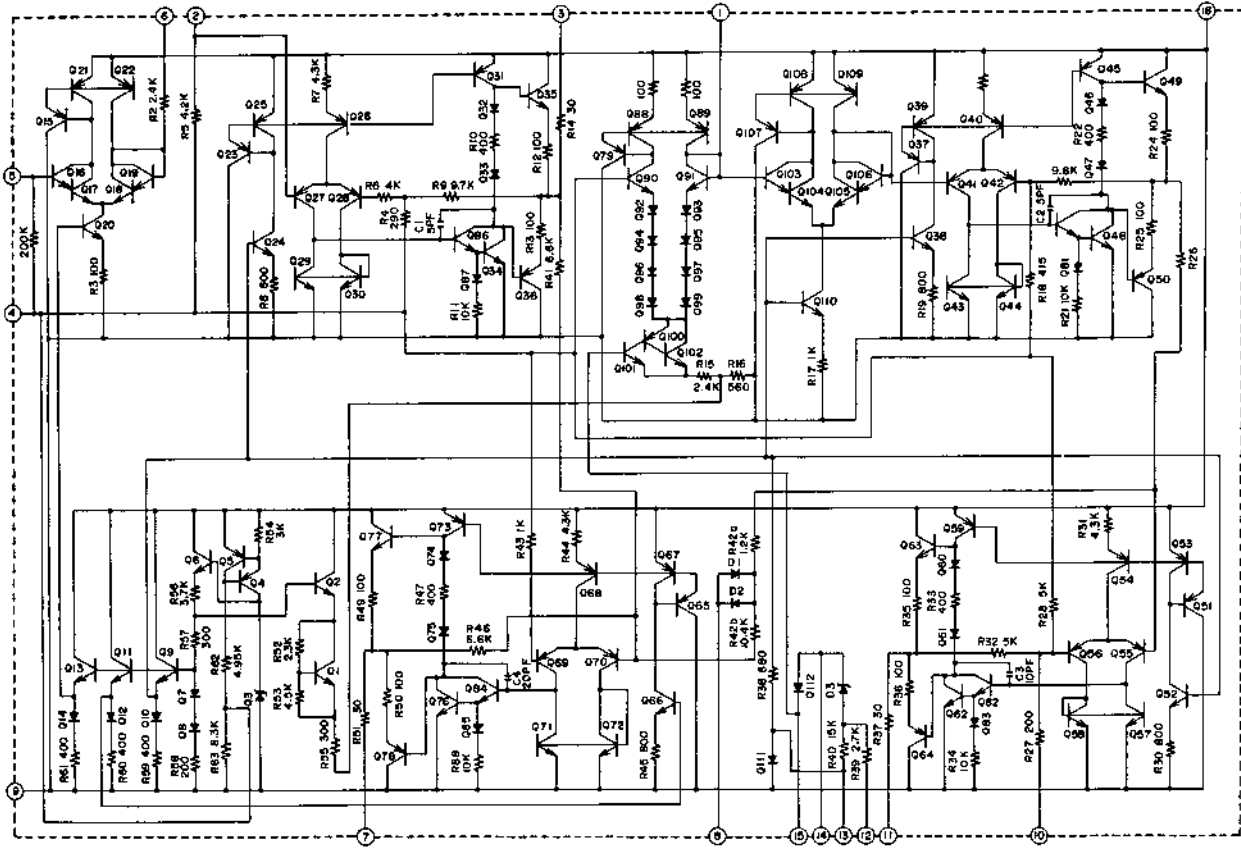

SECTION 3

SCHEMATIC DIAGRAM

1. CS-703D NO. 1580250A SCHEMATIC DIAGRAM
2. GXC-704D NO. 1580251A SCHEMATIC DIAGRAM

GXC-704D

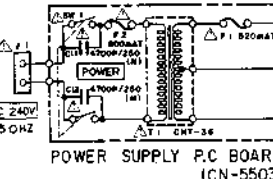
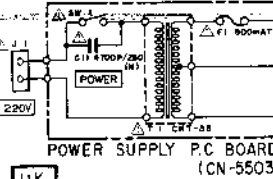
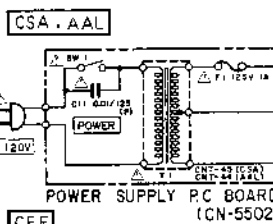
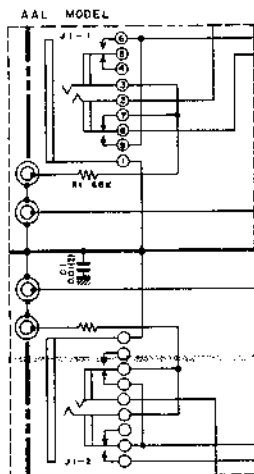
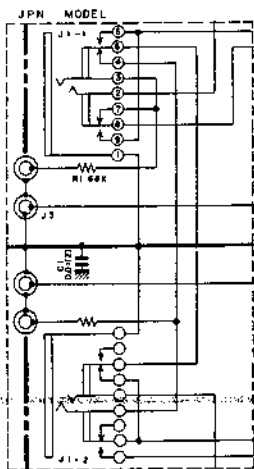

LEFT

REC/PB HEAD

MIC

LINE IN

LINE OUT

D.I.N

LINE IN

LINE OUT

MIC

REC/PB HEAD

RIGHT

JPN

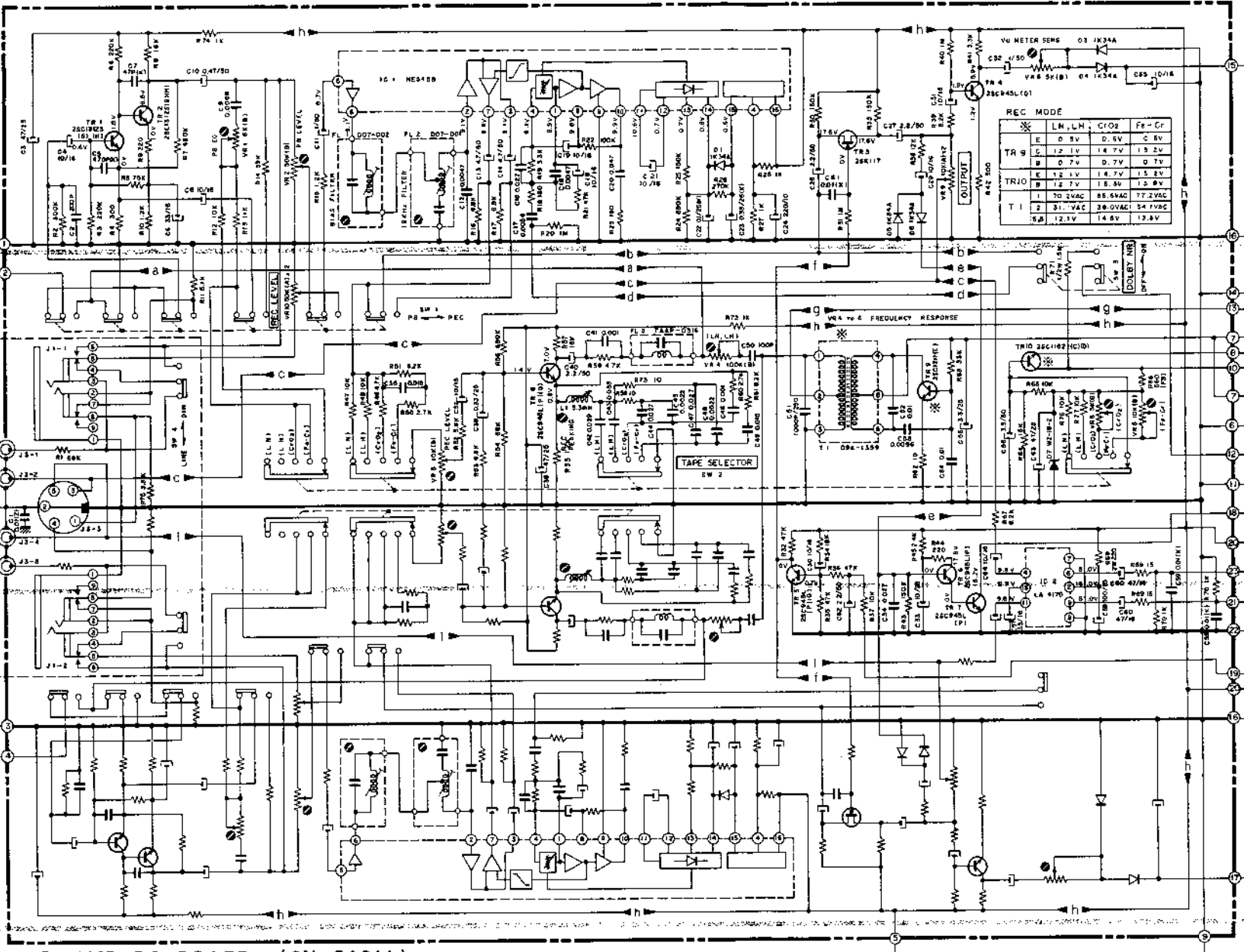

PRE AMP P.C BOARD (CN-5401A)

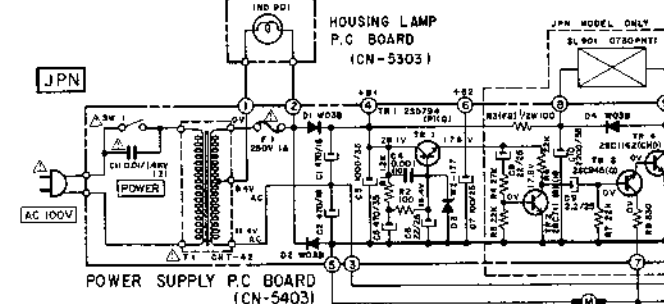

POWER SUPPLY P.C BOARD (CN-5403)

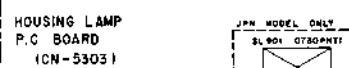

HOUSING LAMP P.C BOARD (CN-5303)

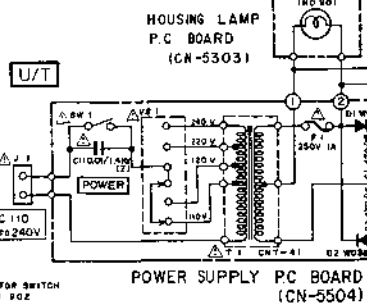

POWER SUPPLY P.C BOARD (CN-5504)

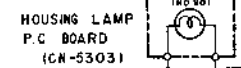

HOUSING LAMP P.C BOARD (CN-5303)

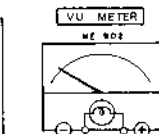
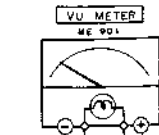
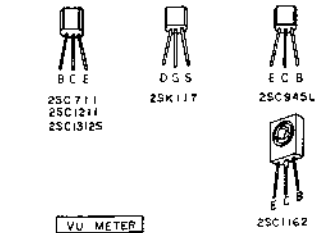

WARNING: INDICATES SAFETY CRITICAL COMPONENTS FOR CONTINUED SAFETY, REPLACE SAFETY CRITICAL COMPONENTS ONLY WITH MANUFACTURER'S RECOMMENDED PARTS.

NOTE: UNLESS OTHERWISE SPECIFIED, ALL RESISTORS IN OHMS 1/4W (J), ALL CAPACITORS IN UF 50WV (J).

GXC-704D SCHEMATIC DIAGRAM NO. 1580251A

CS-703D

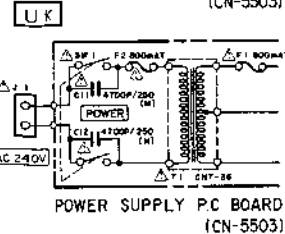
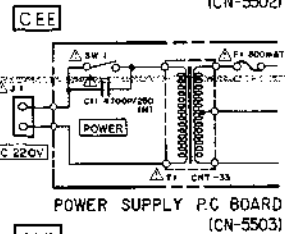
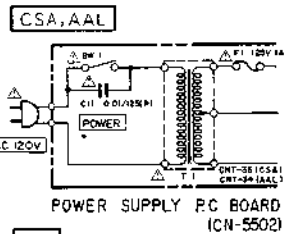
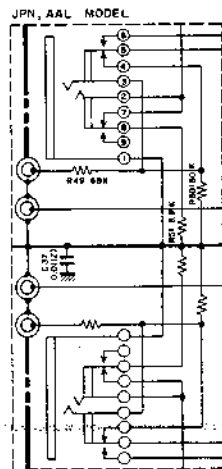
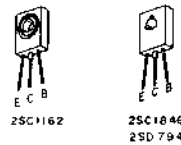

LEFT

REC/PB HEAD

MIC

LINE IN

LINE OUT

DIN REC/PLAY

LINE OUT

LINE IN

MIC

REC/PB HEAD

RIGHT

MIC

REC/PB HEAD

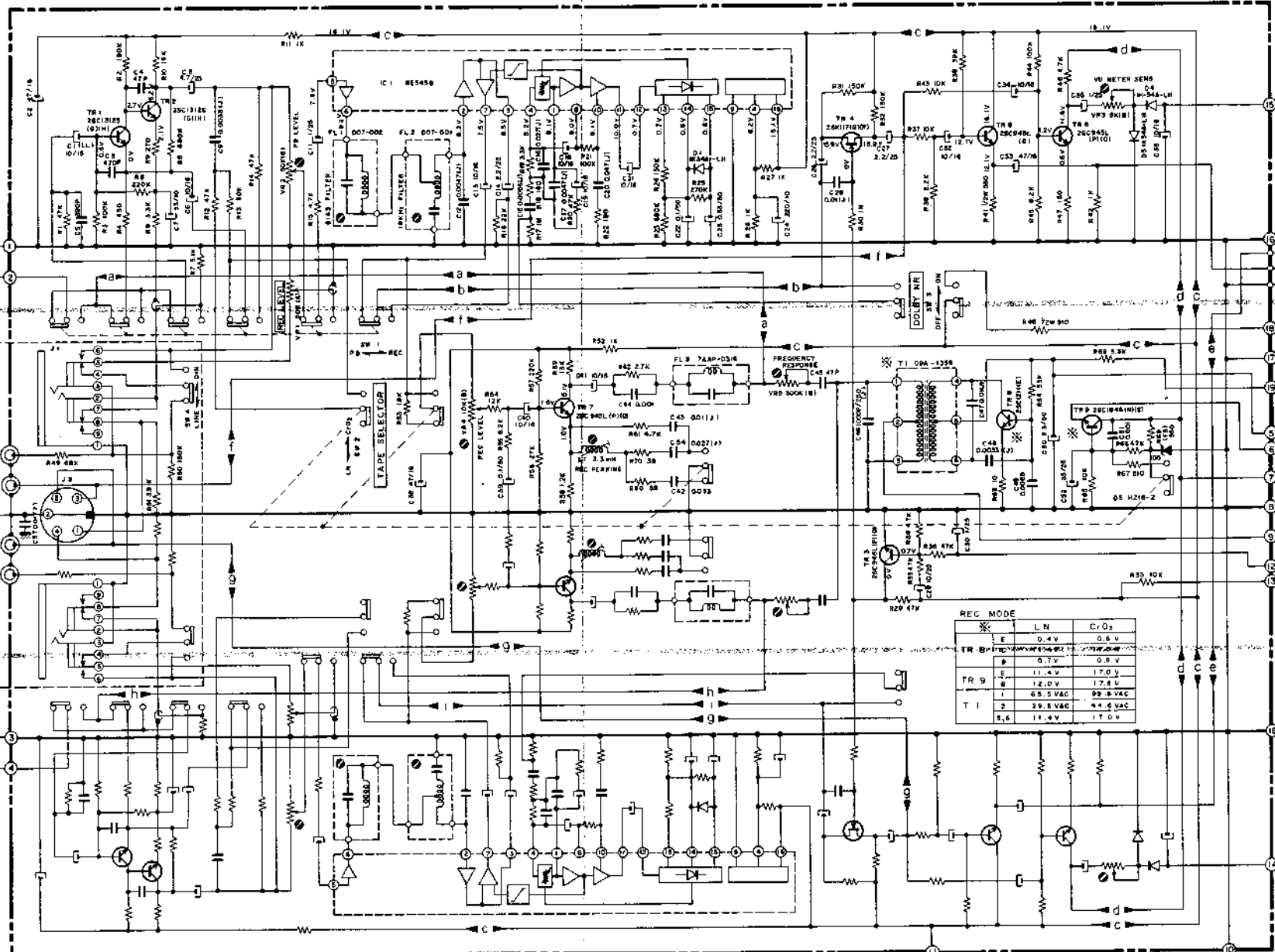

REC/PB HEAD

MIC

LINE IN

LINE OUT

MIC

REC/PB HEAD

PRE AMP P.C. BOARD (CN-5501A)

REC/PB HEAD

MIC

LINE IN

LINE OUT

MIC

REC/PB HEAD

LAMP P.C. BOARD (CN-5506)

HOUSING LAMP P.C. BOARD (CN-5303)

JPN MODEL ONLY

POWER SUPPLY P.C. BOARD (CN-5403)

POWER SUPPLY P.C. BOARD (CN-5504)

LAMP P.C. BOARD (CN-5506)

HOUSING LAMP P.C. BOARD (CN-5303)

JPN MODEL ONLY

POWER SUPPLY P.C. BOARD (CN-5504)

POWER SUPPLY P.C. BOARD (CN-5504)

TR	LN	C ₁ O ₂
E	0.4V	0.5V
B	0.7V	0.8V
TR 9	11.5V	17.0V
B	12.0V	17.8V
I	65.5 VAC	22.5 VAC
2	29.5 VAC	4.4 VAC
T 1	11.4V	17.0V

WARNING: INDICATES SAFETY CRITICAL COMPONENTS. FOR CONTINUED SAFETY, REPLACE SAFETY CRITICAL COMPONENTS ONLY WITH MANUFACTURER'S RECOMMENDED PARTS.

AVERTISSEMENT: ΔIL INDIQU LES COMPOSANTS CRITIQUES DE SÛRETÉ. POUR MAINTENIR LE DEGRÉ DE SÛRETÉ DE L'APPAREIL, NE REMPLACEZ LES COMPOSANTS DONT LE FONCTIONNEMENT EST CRITIQUE POUR LA SÛRETÉ QUE PAR DES PIÈCES RECOMMANDÉES PAR LE FABRICANT.

NOTE
UNLESS OTHERWISE SPECIFIED
ALL RESISTORS IN OHMS 1/4W (J)
ALL CAPACITORS IN μF 50V (K)
(FS) = FAIL SAFE RESISTORS

CS-703D
SCHEMATIC DIAGRAM
NO. 1580250A