

AKAI SERVICE MANUAL

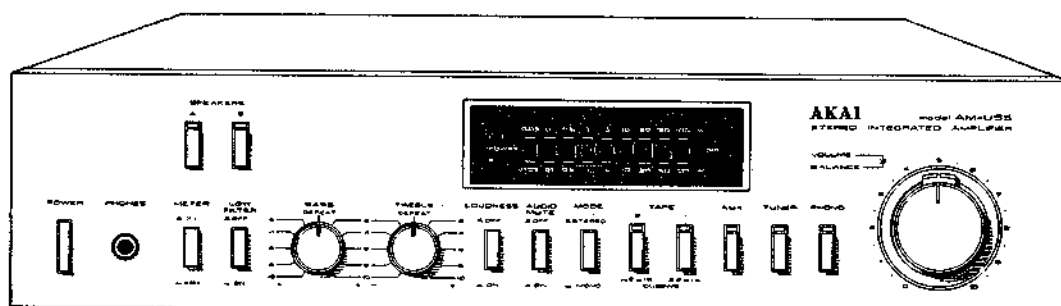
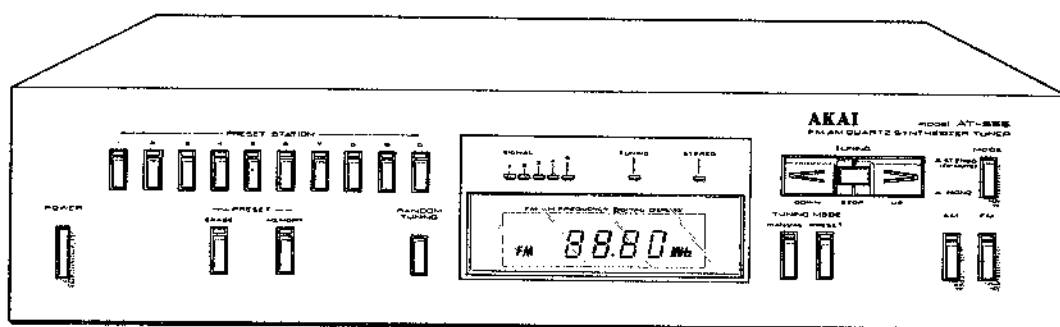

FM/AM QUARTZ SYNTHESIZER TUNER

MODEL **AT-S55/L**

STEREO INTEGRATED AMPLIFIER

MODEL **AM-U55/J**

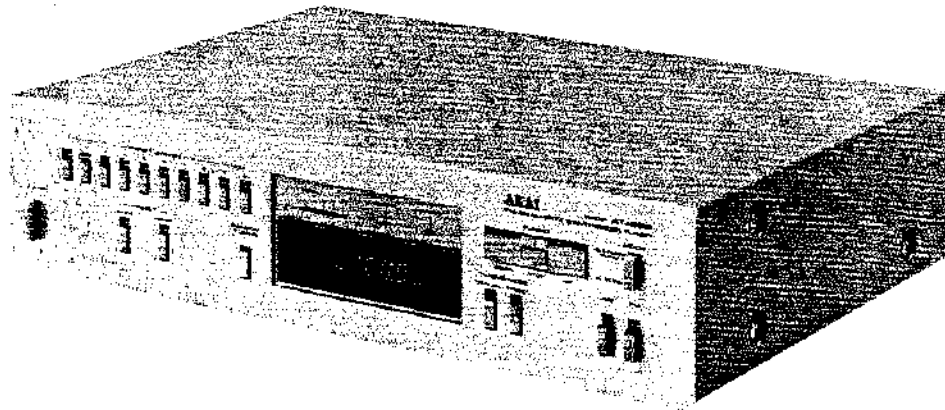

AT-S55/L

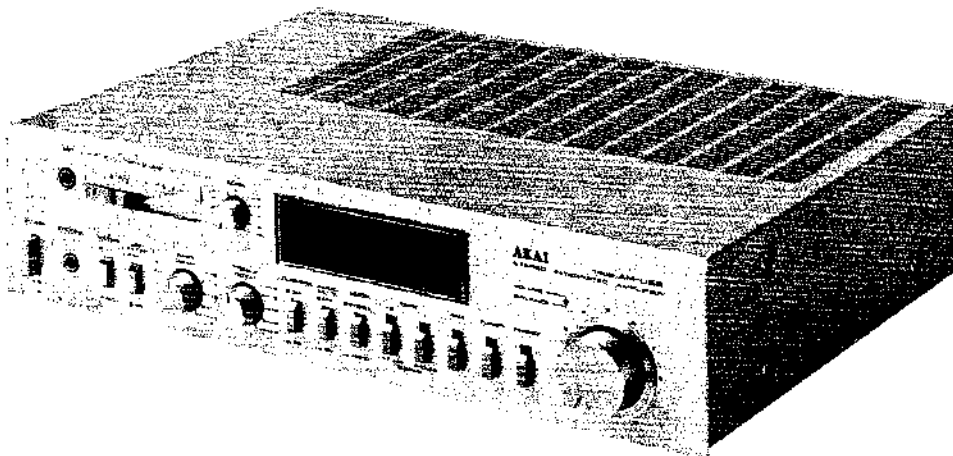

AM-U55/J

FM/AM QUARTZ SYNTHESIZER TUNER
MODEL AT-S55/L
STEREO INTEGRATED AMPLIFIER
MODEL AM-U55/J

THIS MANUAL IS ALSO APPLICABLE TO BLACK PANEL MODELS

SECTION 1	MODEL AT-S55/L SERVICE MANUAL	3
SECTION 2	MODEL AM-U55/J SERVICE MANUAL	25
SECTION 3	PARTS LIST	49
SECTION 4	SCHEMATIC DIAGRAM	61

SECTION 1

SERVICE MANUAL

MODEL AT-S55/L

TABLE OF CONTENTS

I.	SPECIFICATIONS	4
II.	DISMANTLING OF UNIT	5
III.	CONTROLS	6
IV.	PRINCIPAL PARTS LOCATION	7
V.	VOLTAGE CONVERSION	8
VI.	ADJUSTMENTS	9
	1. AM (AT-S55L: MW) SECTION ADJUSTMENTS	12
	2. LW SECTION ADJUSTMENTS	13
	3. FM SECTION ADJUSTMENTS	14
VII.	CLASSIFICATION OF VARIOUS P.C BOARDS	16
	1. P.C BOARD TITLES AND IDENTIFICATION NUMBERS	16
	2. MODEL AT-S55; COMPOSITION OF VARIOUS P.C BOARDS	17
	3. MODEL AT-S55L; COMPOSITION OF VARIOUS P.C BOARDS	21

For basic adjustments, measuring methods, and operating principles, refer to GENERAL TECHNICAL MANUAL.

I . SPECIFICATIONS

FM TUNER SECTION

TUNING FREQUENCY RANGE	87.4MHz to 108.1MHz
USABLE SENSITIVITY (300 ohms)	1.9 μ V
CAPTURE RATIO	1.3dB
SELECTIVITY (IHF, 400kHz)	65dB
IMAGE REJECTION	80dB
IF REJECTION	90dB
SPURIOUS REJECTION	85dB
AM SUPPRESSION	60dB
SUB CARRIER SUPPRESSION	60dB
S/N RATIO (MONO/STEREO)	75dB/65dB
T.H.D. (MONO/STEREO)	0.1%/0.15%
STEREO SEPARATION (1kHz)	50dB
MUTING LEVEL	22dB

AM TUNER SECTION (AT-S55L:MW)

TUNING FREQUENCY RANGE	530kHz to 1,610kHz for U.S.A. and Canada 522kHz to 1,611kHz for other countries
USABLE SENSITIVITY (BAR) (EXT.)	100 μ V/m 10 μ V
SELECTIVITY (IHF)	30dB
IMAGE REJECTION	48dB
IF REJECTION	75dB
S/N RATIO	55dB
T.H.D.	0.3%

LW TUNER SECTION (AT-S55L ONLY)

TUNING FREQUENCY RANGE	137kHz to 362kHz
USABLE SENSITIVITY (BAR) (EXT.)	200 μ V/m 20 μ V
SELECTIVITY (IHF)	30dB
IMAGE REJECTION	48dB
IF REJECTION	75dB
S/N RATIO	55dB
T.H.D.	0.3%

OUTPUT SECTION

OUTPUT LEVEL FM (100% MOD.) AM (30% MOD.)	775mV 250mV
POWER CONSUMPTION	20 Watts
POWER REQUIREMENTS	120V, 60Hz for Canada and U.S.A. 220V, 50Hz for Europe except UK 240V, 50Hz for UK and Australia 110V/220V/240V, 50/60Hz internally switchable for the other countries
DIMENSIONS	440(W) x 105(H) x 327(D) mm (17.3 x 4.1 x 12.9 inches)
WEIGHT	5.4 kg (11.2 lbs)

* For improvement purposes, specifications and design are subject to change without notice.

II. DISMANTLING OF UNIT

AT-S55/L

In case of trouble, etc. necessitating dismantling, please dismantle in the order shown in the photographs. Reassemble in reverse order.

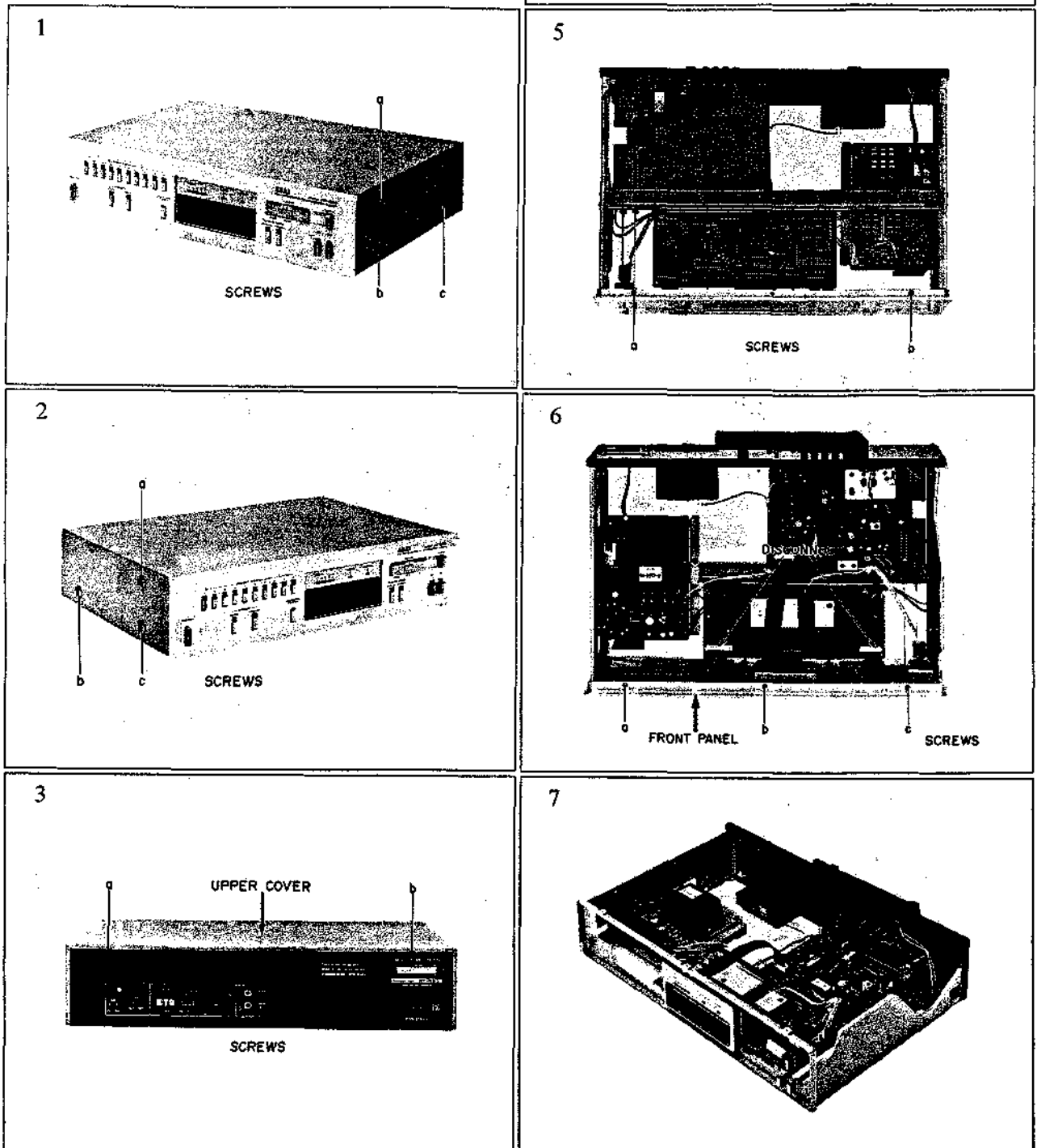

III. CONTROLS

2000 1000 500 250 125 62.5 31.25 15.625 7.8125 3.90625

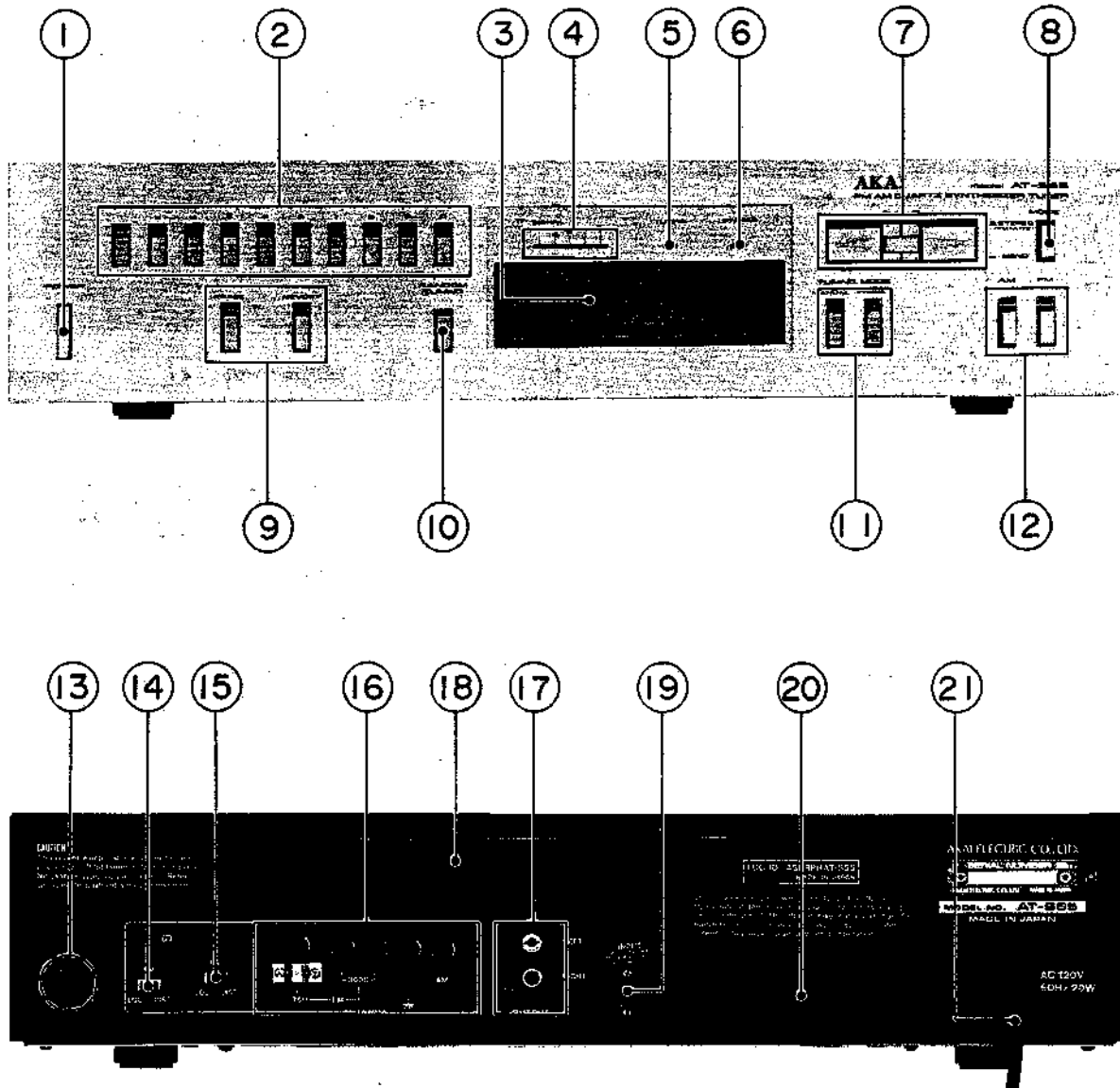

Fig. 1 Controls

- | | |
|---|--|
| 1. POWER SWITCH | 12. BAND SWITCHES AND INDICATORS |
| 2. PRESET STATION KEYS AND INDICATORS | 13. AM ANTENNA (ANT) SELECTOR (AT-S65L ONLY) |
| 3. DIGITAL LED DISPLAY | 14. AM LOCATION SELECTOR |
| 4. SIGNAL STRENGTH INDICATORS | 15. FM LOCATION SELECTOR |
| 5. FM TUNING INDICATOR | 16. FM/AM ANTENNA TERMINALS |
| 6. FM STEREO INDICATOR | 17. OUTPUT JACKS (LEFT AND RIGHT) |
| 7. TUNING KEYS | 18. AM FERRITE BAR ANTENNA |
| 8. FM MODE SELECTOR | 19. AC ADAPTER INPUT FOR STATION MEMORY |
| 9. PRESET SWITCHES AND INDICATORS | 20. BATTERY COMPARTMENT FOR STATION MEMORY |
| 10. RANDOM TUNING SWITCH | 21. AC CORD (CEE, UK, SAA: AC INLET) |
| 11. TUNING MODE SWITCHES AND INDICATORS | |

IV. PRINCIPAL PARTS LOCATION

AT-S55/L

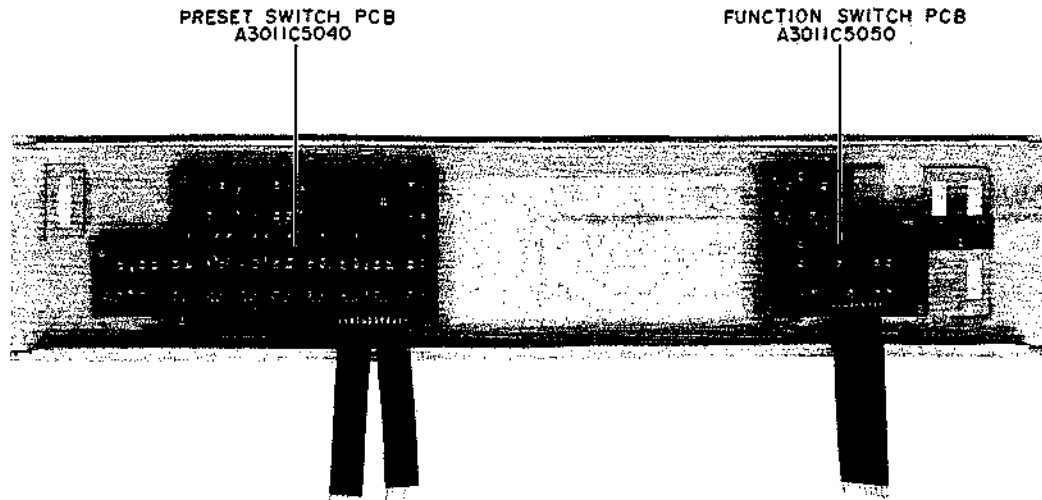

Fig. 2 Back View of Front Panel

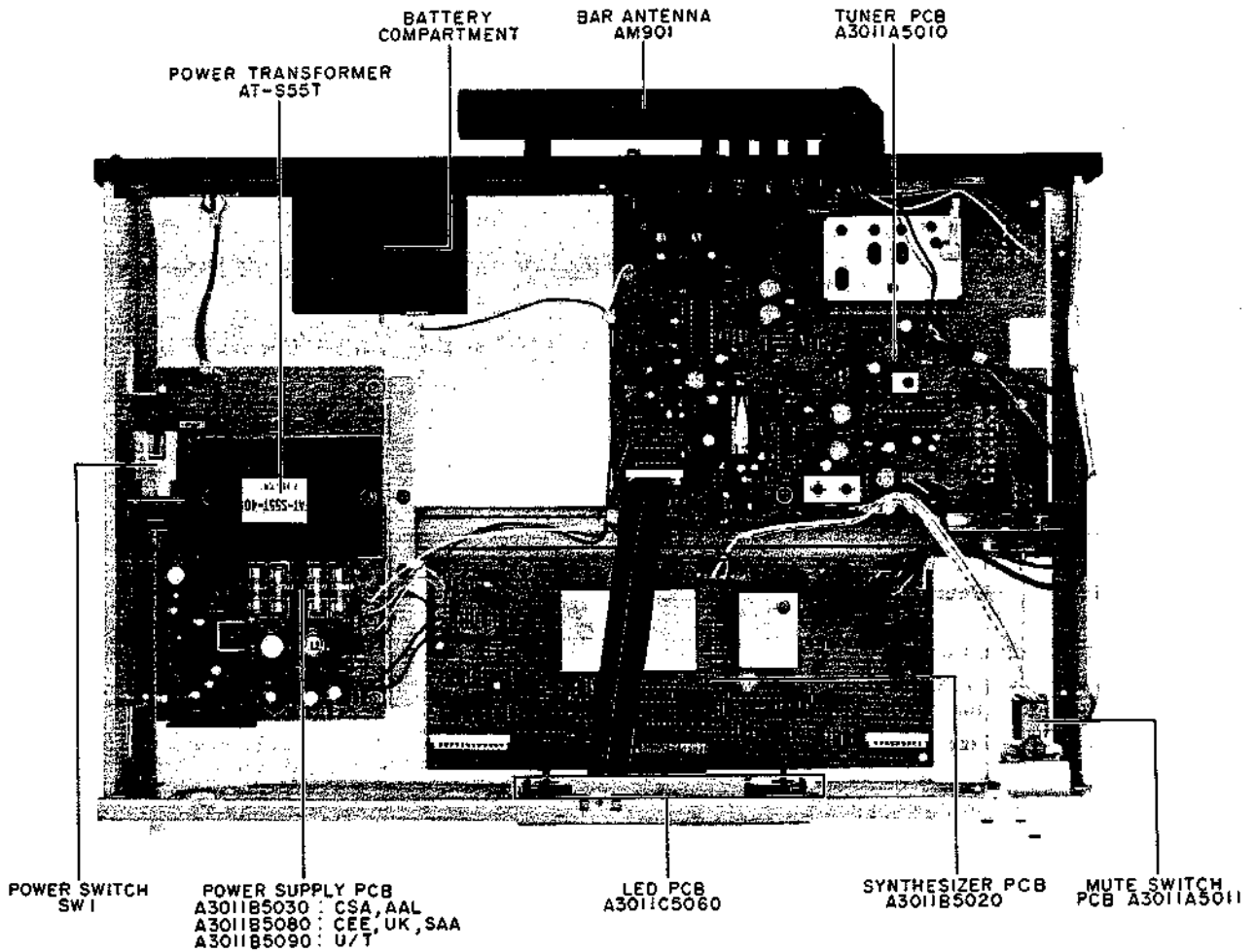

Fig. 3 Top View

V. VOLTAGE CONVERSION

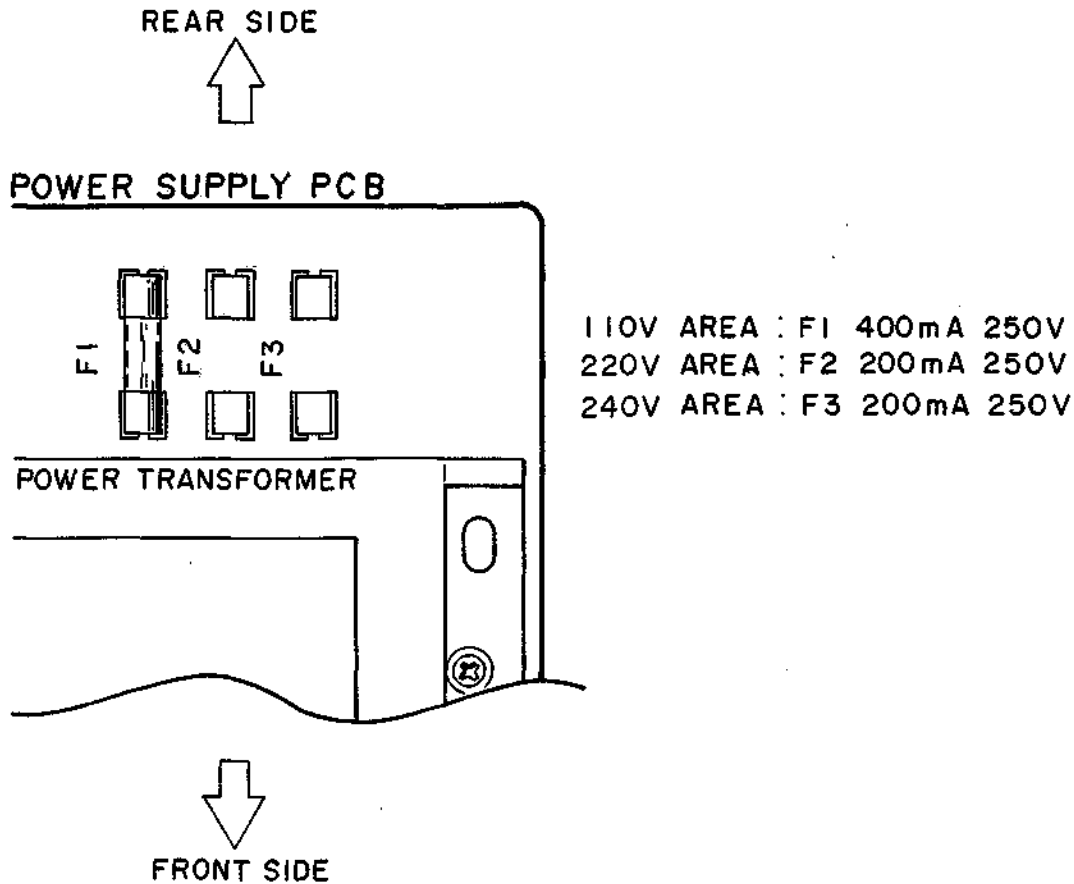

Fig. 4 Voltage Conversion (U/T Model Only)

Models for Canada, U.S.A., Europe, UK, and Australia are not equipped with this facility.

Each machine is preset at the factory according to destination but some machines can be set to 110V, 220V or 240V as required.

If voltage change is necessary, this can be accomplished as follows.

- 1) Disconnect AC Power Cord.
- 2) Loosen holding screws and remove upper cover.
- 3) Remove existing Line Voltage Fuse and insert required Line Voltage Fuse in the proper fuse holder.

VI. ADJUSTMENTS

AT-S55/L

BAR ANTENNA CORE LOW RANGE SENS.

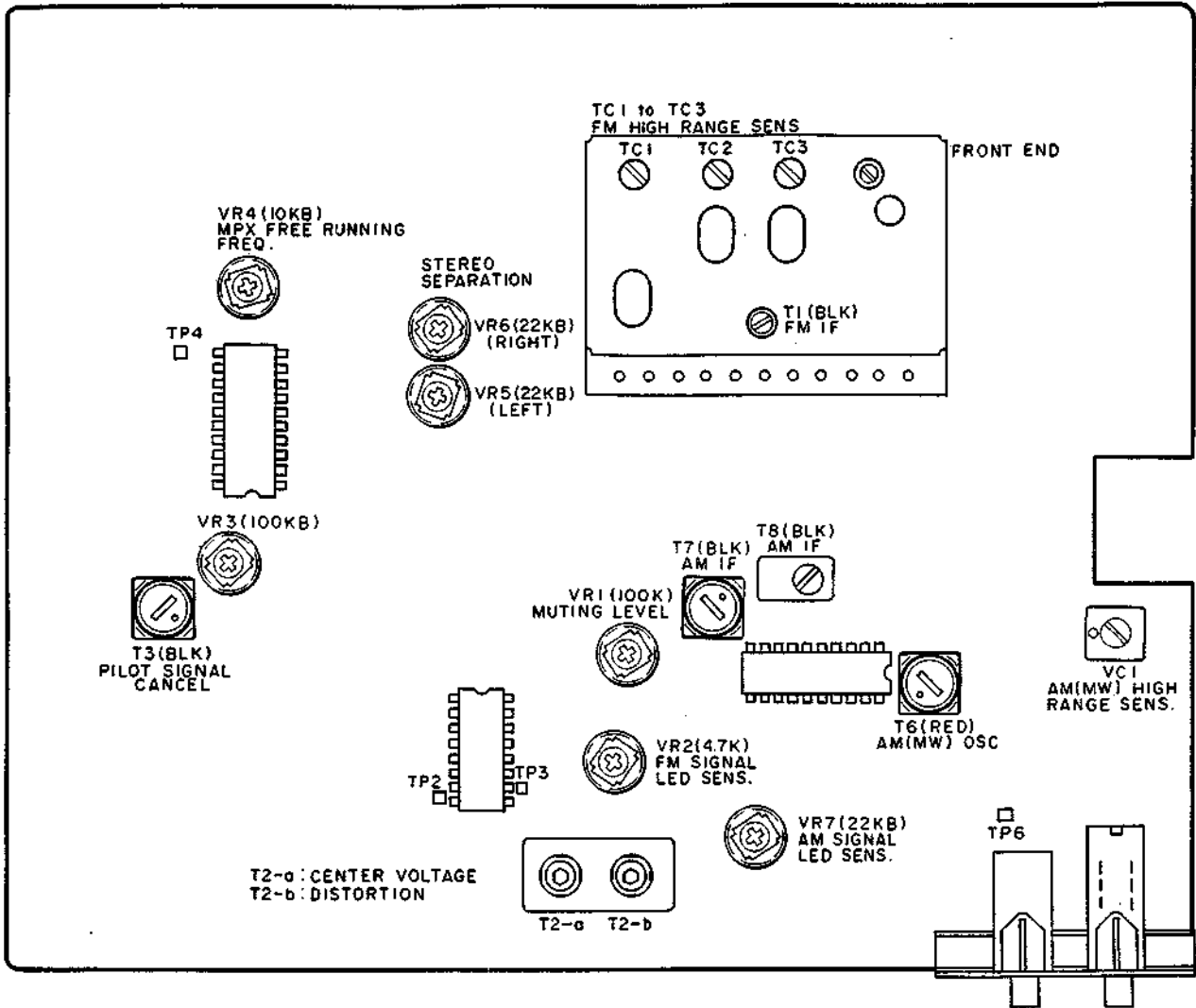

Fig. 5 Tuner P.C Board A3011A5010 and Bar Antenna (AT-S55)

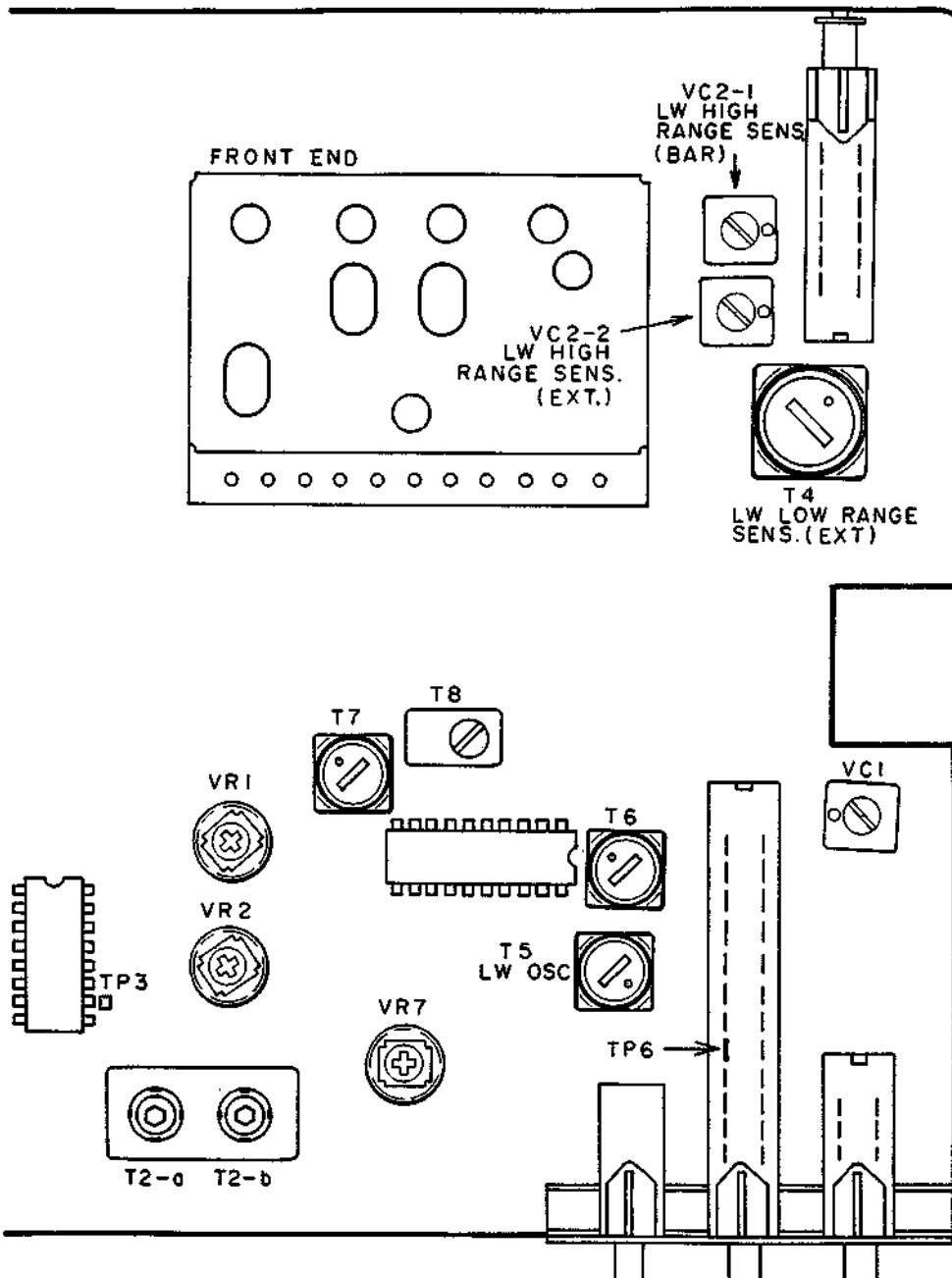
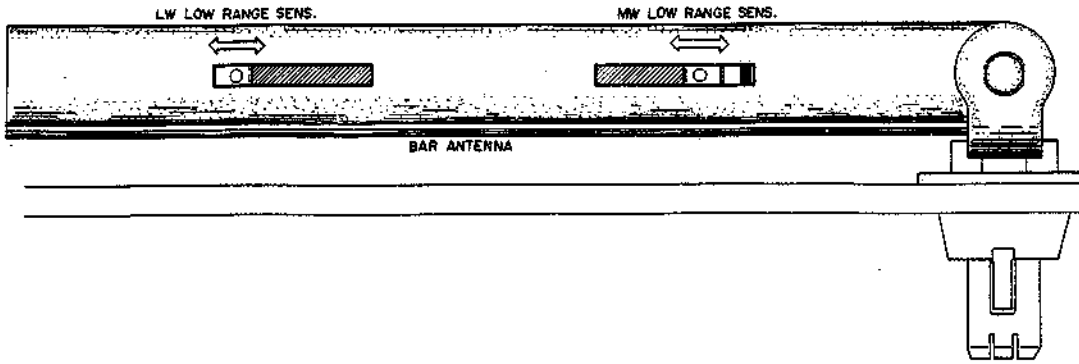

Fig. 6 Tuner P.C Board A3011A5010 and Bar Antenna (AT-S55L)

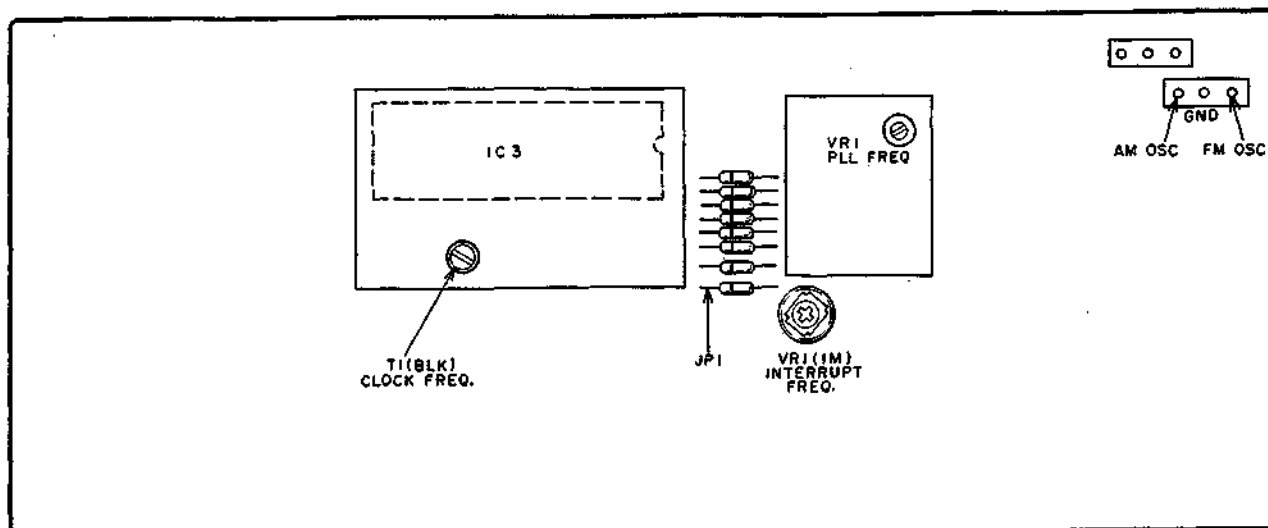

Fig. 7 Synthesizer P.C Board A3011B5020

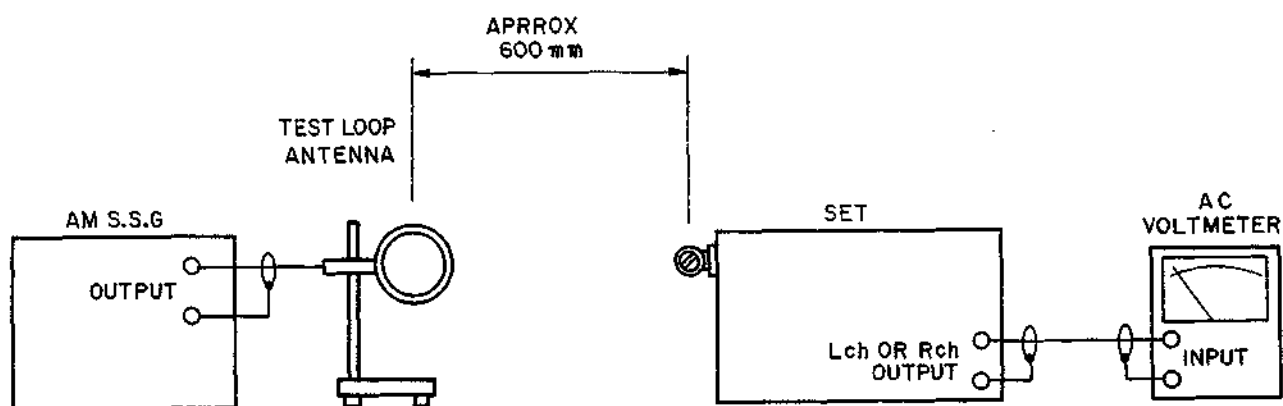

Fig. 8 Instrument Connections for AM(MW) Section Adjustments and Steps 2, 3 of LW Section Adjustments

1. AM (AT-S55L: MW) SECTION ADJUSTMENTS (Refer to Figs. 5 to 8)

Unless otherwise specified, use the adjustment points provided on the Tuner P.C Board (Fig. 5).

Step	Adjustment Item	Adjustment Point	Result	Remarks
1	Clock Frequency	T1 (BLK) Synthesizer P.C Board (Fig. 7)	420kHz	Connect a Frequency Counter between IC3 Pin (28) and GND on the Synthesizer P.C Board.
2	Interrupt Frequency	VR1 (1M) Synthesizer P.C Board (Fig. 7)	400Hz	Connect a Frequency Counter between JP1 (IC3 Pin (32)) and GND on the Synthesizer P.C Board.
3	PLL Frequency	VC1 Synthesizer P.C Board (Fig. 7)	118.800MHz (Digital display indicating frequency +10.7MHz)	BAND switch to FM. Connect a Frequency Counter between FM OSC and GND on the Synthesizer P.C Board. Adjust the Digital Display to 108.1MHz.
4	AM (MW) OSC	T6 (RED)	719kHz	BAND switch to AM (MW). Short TP6 to GND on the Tuner P.C Board. Connect a Frequency Counter between AM OSC and GND on the Synthesizer P.C Board.
5	AM IF Coil	T7 (BLK) T8 (BLK)	Maximum Output	1,000kHz (1,008kHz), 50dB, 400Hz (30%) input.
6	Low Range Sensitivity 600kHz (603kHz)	Bar Antenna Core ATS55: Fig. 5 AT-S55L: Fig. 6	Maximum Output Distortion Factor: Less than 10%	600kHz (603kHz), 50dB, 400Hz (30%) input.
7	High Range Sensitivity 1,400kHz (1,404kHz)	VC1	Maximum Output Distortion Factor: Less than 10%	1,400kHz (1,404kHz), 50dB, 400Hz (30%) input.
8				Readjust in Steps 6 and 7.
9	Signal LED Sensitivity	VR7		1,000kHz (1,008kHz), 74dB input. Adjust VR7 to a point where 5th LED of SIGNAL LED lights up.

2. LW SECTION ADJUSTMENTS (AT-S55L Only; Refer to Figs. 6, 8, 9)

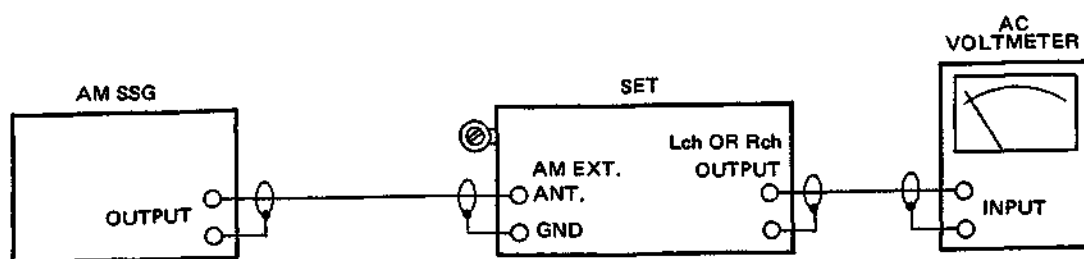

Fig. 9 Instrument Connections for Steps 4 and 5 of LW Section Adjustments

Unless otherwise specified, use the adjustment points provided on the Tuner P.C Board (Fig. 6).

Step	Adjustment Item	Adjustment Point	Result	Remarks
1	LW OSC	T5	530kHz	BAND switch to LW. Short TP6 to GND on the Tuner P.C Board. Connect a Frequency Counter between AM OSC and GND on the synthesizer P.C Board.
2	Low Range Sensitivity (Bar Antenna)	Bar Antenna Core (Fig. 6)	Maximum Output Distortion Factor: Less than 10%	ANTENNA SELECTOR to INT. 160kHz, 50dB, 400Hz (30%) input. (Refer to Fig. 8)
3	High Range Sensitivity (Bar Antenna)	VC2-1	Maximum Output Distortion Factor: Less than 10%	300kHz, 50dB, 400Hz (30%) input. (Refer to Fig. 8)
4	Low Range Sensitivity (EXT. Antenna)	T4	Maximum Output Distortion Factor: Less than 10%	ANTENNA SELECTOR to EXT. 160kHz, 20dB, 400Hz (30%) input. (Refer to Fig. 9)
5	High Range Sensitivity (EXT. Antenna)	VC2-2	Maximum Output Distortion Factor: Less than 10%	300kHz, 20dB, 400Hz (30%) input. (Refer to Fig. 9)

3. FM SECTION ADJUSTMENTS (Refer to Figs. 5, 10)

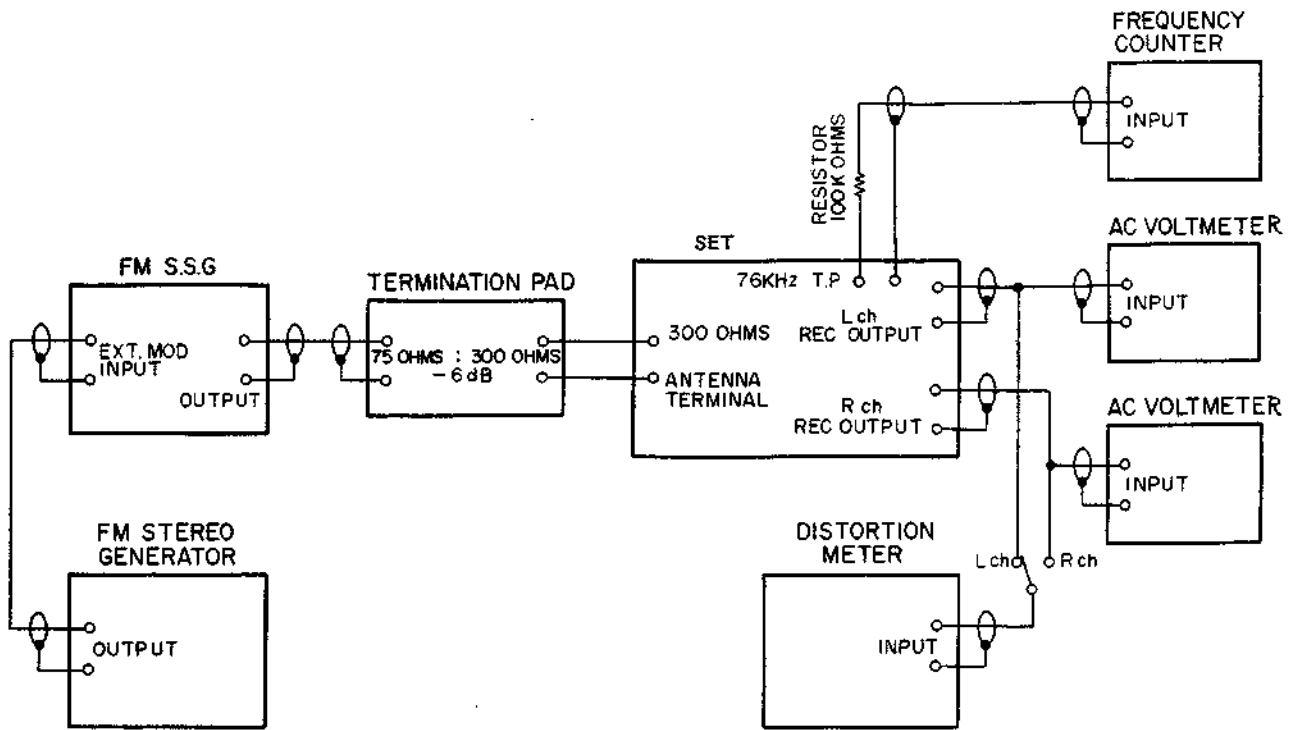

Fig. 10 Instrument Connections

Unless otherwise specified, use the adjustment points provided on the Tuner P.C Board (Fig. 5).

Step	Adjustment Item	Adjustment Point	Result	Remarks
1	Front-end IF Coil	T1 (BLK) (Front-end)	Maximum Noise Level	BAND switch to FM, and MODE to MONO. Turns only noise without interference from broadcasting.
2	Center Voltage	T2-a	Centered Tuning Meter Indication	Connect a Center Tuning Meter between TP2 and TP3. (See Note 1) Turns only noise without interference from broadcasting.
3	Distortion Factor	T2-b	Distortion Factor: Less than 0.3%	98MHz, 60dB, 1kHz (mono 100%) input. Less than 0.3% in both channels.
4	MPX Free Running Frequency	VR4 (10KB)	76kHz±50Hz	Connect a Frequency Counter between TP4 and GND on the Tuner P.C Board. (See Note 2)
5	High Range Sensitivity	TC1, TC2, TC3 (Front-end)	Distortion Factor: Less than 3%	MODE switch to MONO. 108MHz, Less than 8dB, 1kHz (mono) input.
6	Confirmation of Low Range Sensitivity		Distortion Factor: Less than 3%	88MHz, Less than 8dB, 1kHz (mono) input. (See Note 3, 4)
7	Pilot Signal Cancel	T3 (BLK) VR3 (100KB)	Minimum Output	MODE switch to STEREO. 98MHz, 60dB (stereo), Pilot signal only input.
8	Stereo Separation (Left → Right)	VR5 (22KB)	More than 40dB	98MHz, 60dB, 1kHz (stereo 100%) Lch input. Minimum output of Rch.
9	Stereo Separation (Right → Left)	VR6 (22KB)	More than 40dB	98MHz, 60dB, 1kHz (stereo 100%) Rch input. Minimum output of Lch.
10	Confirmation of Stereo Distortion Factor		Distortion Factor: Less than 0.5%	98MHz, 60dB, 1kHz (stereo 100%) input. If distortion exceeds 0.5%, first check according to Steps 2, 3, 4, 8 and 9, and then readjust according to Step 1.
11	Signal LED Sensitivity	VR2 (4.7K)		98MHz, 40dB input. Adjust VR2 to a point where 5th LED of SIGNAL LED lights up. (See Note 5)
12	Muting Level	VR1 (100K)	22dB ± 6dB	MODE switch to STEREO. 98MHz, 22dB, 1kHz (mono 100%) input. Adjust VR1 until the output signal is reduced to zero. Vary the SSG output by ±6dB and check muting operation.

Notes:

1. For the Center Meter should be used the tuning meter and the like available as a part of the other models.
2. When connecting a Frequency Counter, connect from TP via 100 kohms resistor. (Refer to Fig. 10)
3. When the specified sensitivity of 8dB cannot be obtained at the two frequency points, 88MHz and 108MHz, repeat the adjustment as described in Step 5.
4. When the distortion factor of sensitivity still does not comply with the data specifications, adjust by turning the Front-end IF Coil core, but not more than 1/2 turn.
5. The 5th LED lights up at 40dB but when the attenuator is decreased 2dB it is extinguished.

VII. CLASSIFICATION OF VARIOUS P.C BOARDS

1. P.C BOARD TITLES AND IDENTIFICATION NUMBERS

1) Model AT-S55

P.C Board Title	P.C Board Number
Tuner P.C Board	A3011A5010
Mute Switch P.C Board	A3011A5011
Synthesizer P.C Board	A3011B5020
Preset Switch P.C Board	A3011C5040
Function Switch P.C Board	A3011C5050
LED P.C Board	A3011C5060
Power Supply P.C Board (CSA, AAL)	A3011B5030
Power Supply P.C Board (CEE, UK, SAA)	A3011B5080
Power Supply P.C Board (U/T)	A3011B5090
Battery P.C Board	A3011D5070

2) Model AT-S55L

P.C Board Title	P.C Board Number
Tuner P.C Board	A3011A5010
Mute Switch P.C Board	A3011A5011
Synthesizer P.C Board	A3011B5020
Preset Switch P.C Board	A3011C5040
Function Switch P.C Board	A3011C5050
LED P.C Board	A3011C5060
Power Supply P.C Board	A3011B5080
Battery P.C Board	A3011D5070

2. MODEL AT-S55; COMPOSITION OF VARIOUS P.C BOARDS

1) Tuner P.C Board A3011A 5010 (4ED), Mute Switch P.C Board A3011A3011 and LED P.C Board A3011C5060

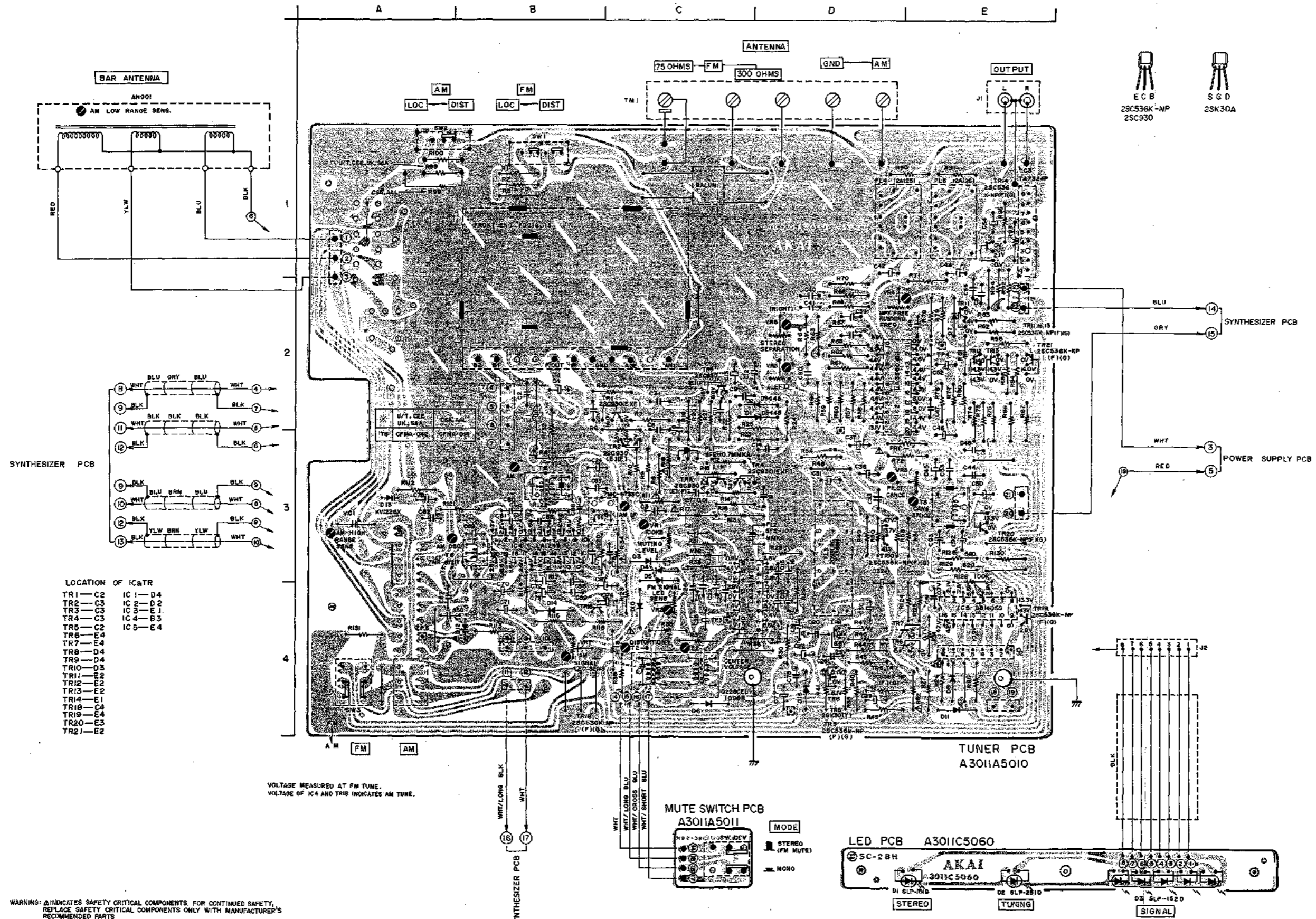

2) Synthesizer P.C Board A3011B5020 (2ED), Preset Switch P.C Board A3011C5040, Function Switch P.C Board A3011C5050 and Battery P.C Board A3011D5070

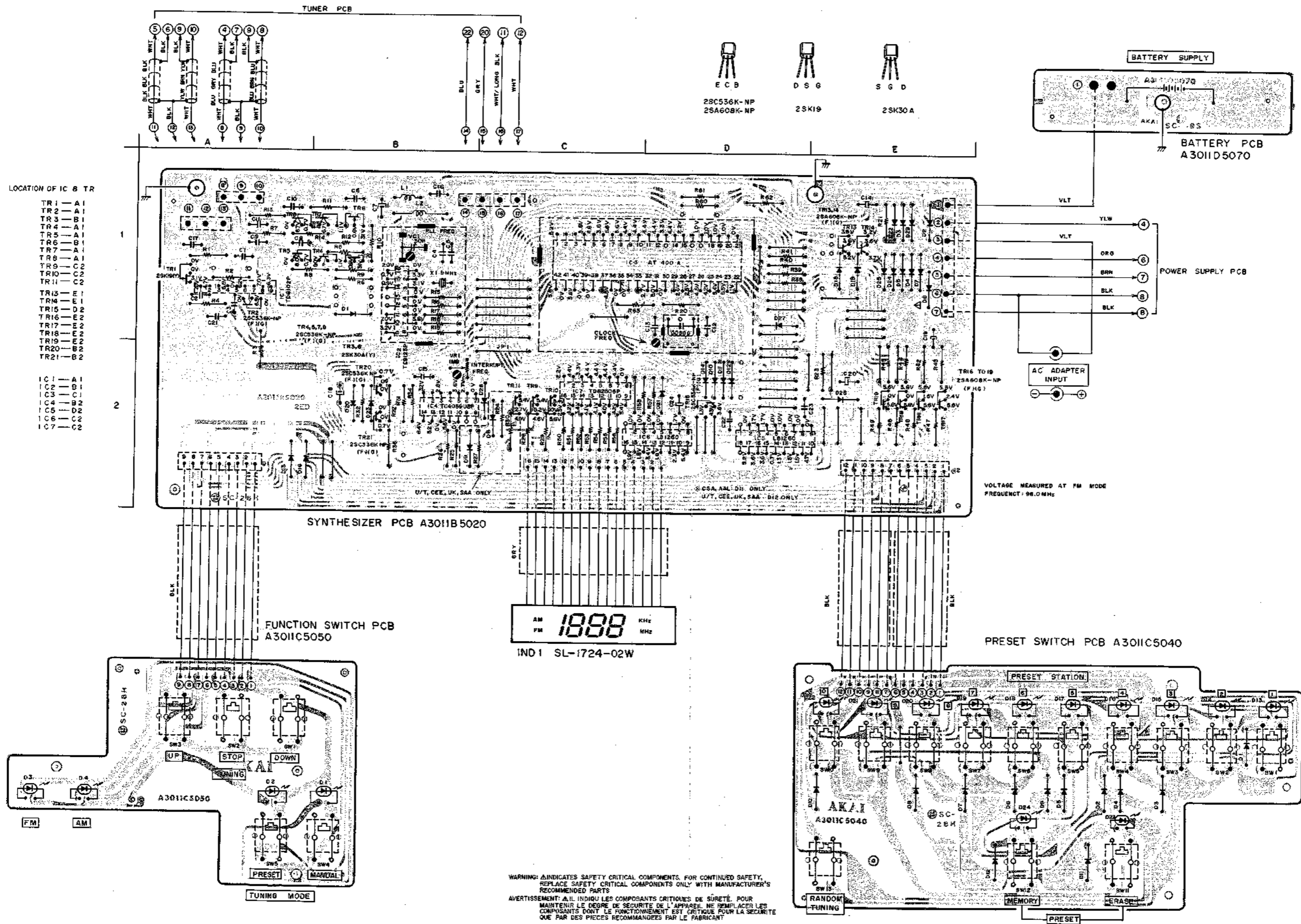

- LOCATION OF IC & TR
- TR1 - A1
 - TR2 - B1
 - TR3 - B1
 - TR4 - A1
 - TR5 - A1
 - TR6 - B1
 - TR7 - A1
 - TR8 - A1
 - TR9 - C2
 - TR10 - C2
 - TR11 - C2
 - TR13 - E1
 - TR14 - E1
 - TR15 - D2
 - TR16 - E2
 - TR17 - E2
 - TR18 - E2
 - TR19 - E2
 - TR20 - B2
 - TR21 - B2
- IC1 - A1
 - IC2 - B1
 - IC3 - C1
 - IC4 - B2
 - IC5 - D2
 - IC6 - C2
 - IC7 - C2

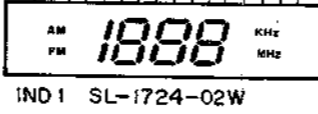

VOLTAGE MEASURED AT FM MODE
FREQUENT - 98.0MHz

3) Power Supply P.C Board A3011B5090 (U/T)

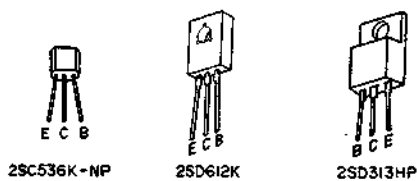

LOCATION OF IC & TR

- TR 1 ~ C4
- TR 2 - C4
- TR 3 - C3
- TR 4 - C4
- TR 5 - B4
- TR 6 - B4
- TR 7 - A4
- TR 8 - B4

- TR 1, 3, 5, 6---2SC536K-NP(F,G)
- TR 2, 4, 7---2SD612K(D, E, F)
- TR 8-----2SD313HP(D, E, F)

TUNER PCB
A3011A5010

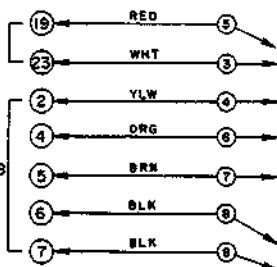

SYNTHESIZER PCB
A3011B5020

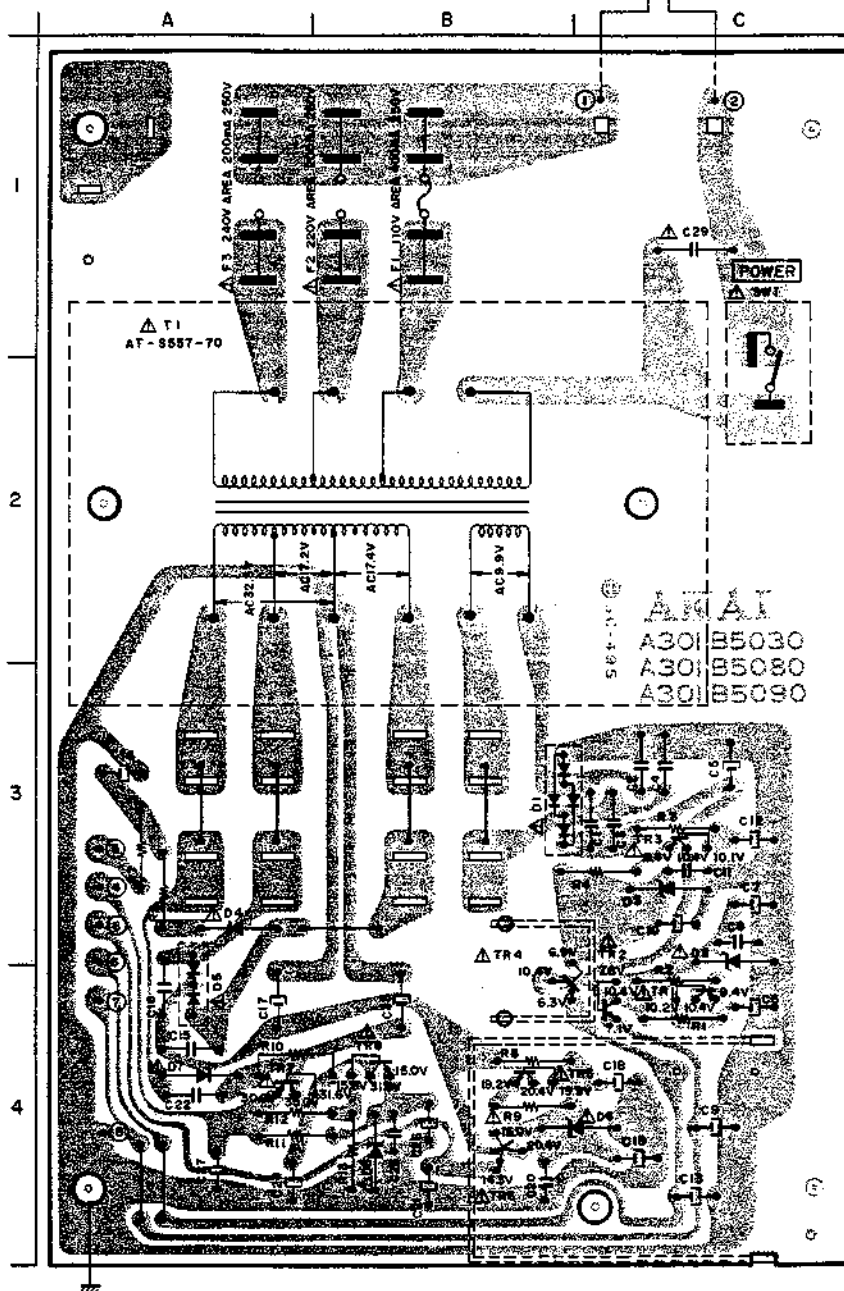

WARNING: Δ INDICATES SAFETY CRITICAL COMPONENTS. FOR CONTINUED SAFETY, REPLACE SAFETY CRITICAL COMPONENTS ONLY WITH MANUFACTURER'S RECOMMENDED PARTS.

AVERTISSEMENT: Δ IL INDIQUÉ LES COMPOSANTS CRITIQUES DE SÛRETÉ. POUR MAINTENIR LE DEGRÉ DE SÛRETÉ DE L'APPAREIL, NE REMPLACER LES COMPOSANTS DONT LE FONCTIONNEMENT EST CRITIQUE POUR LA SÛRETÉ QUE PAR DES PIÈCES RECOMMANDÉES PAR LE FABRICANT.

4) Power Supply P.C Board A3011B5030 (CSA, AAL)

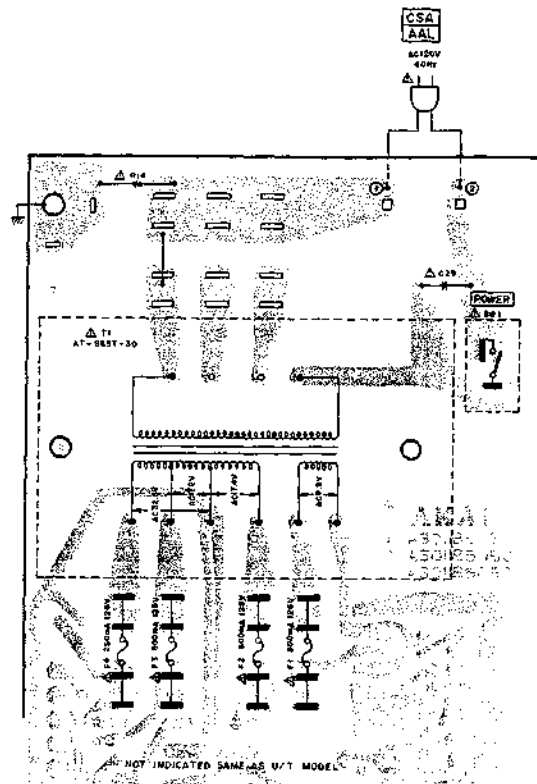

5) Power Supply P.C Board A3011B5080 (CEE, UK, SAA)

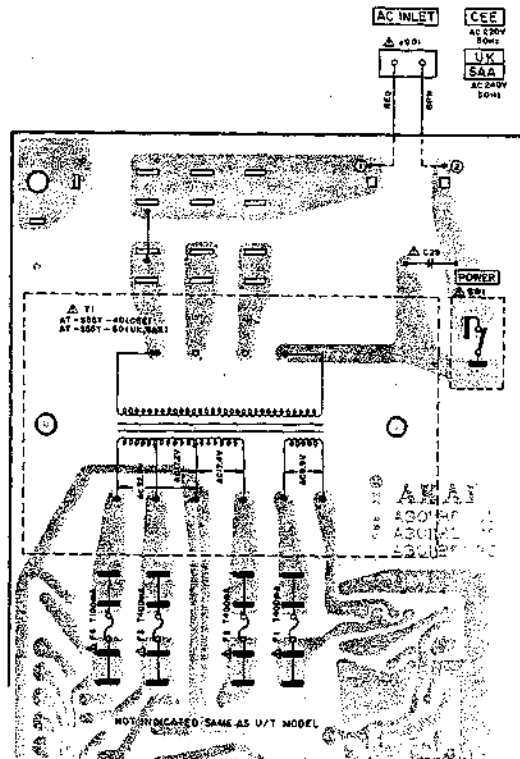

WARNING: Δ INDICATES SAFETY CRITICAL COMPONENTS. FOR CONTINUED SAFETY, REPLACE SAFETY CRITICAL COMPONENTS ONLY WITH MANUFACTURER'S RECOMMENDED PARTS.
 AVERTISSEMENT: Δ IL INDIQUE LES COMPOSANTS CRITIQUES DE SÛRETÉ. POUR MAINTENIR LE DEGRÉ DE SÛRETÉ DE L'APPAREIL, NE REMPLACER LES COMPOSANTS DONT LE FONCTIONNEMENT EST CRITIQUE POUR LA SÛRETÉ QUE PAR DES PIÈCES RECOMMANDÉES PAR LE FABRICANT.

3. MODEL AT-S55L; COMPOSITION OF VARIOUS P.C BOARDS

1) Tuner P.C Board A3011A 5010 (4ED), Mute Switch P.C Board A3011A5011 and LED P.C Board A3011C5060

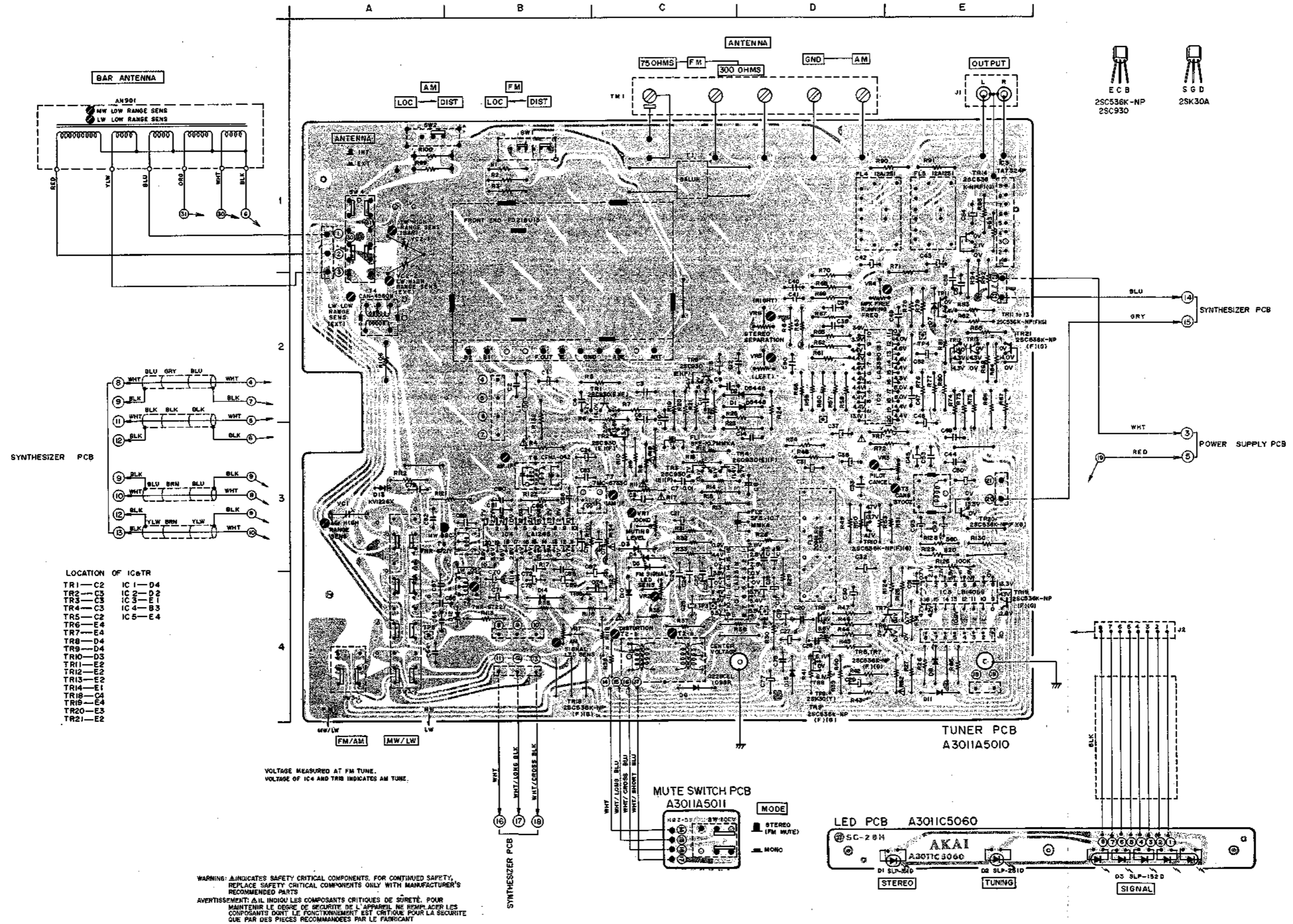

2) Synthesizer P.C Board A3011B5020 (2ED), Preset Switch P.C Board A3011C5040, Function Switch P.C Board A3011C5050 and Battery P.C Board A3011D5070

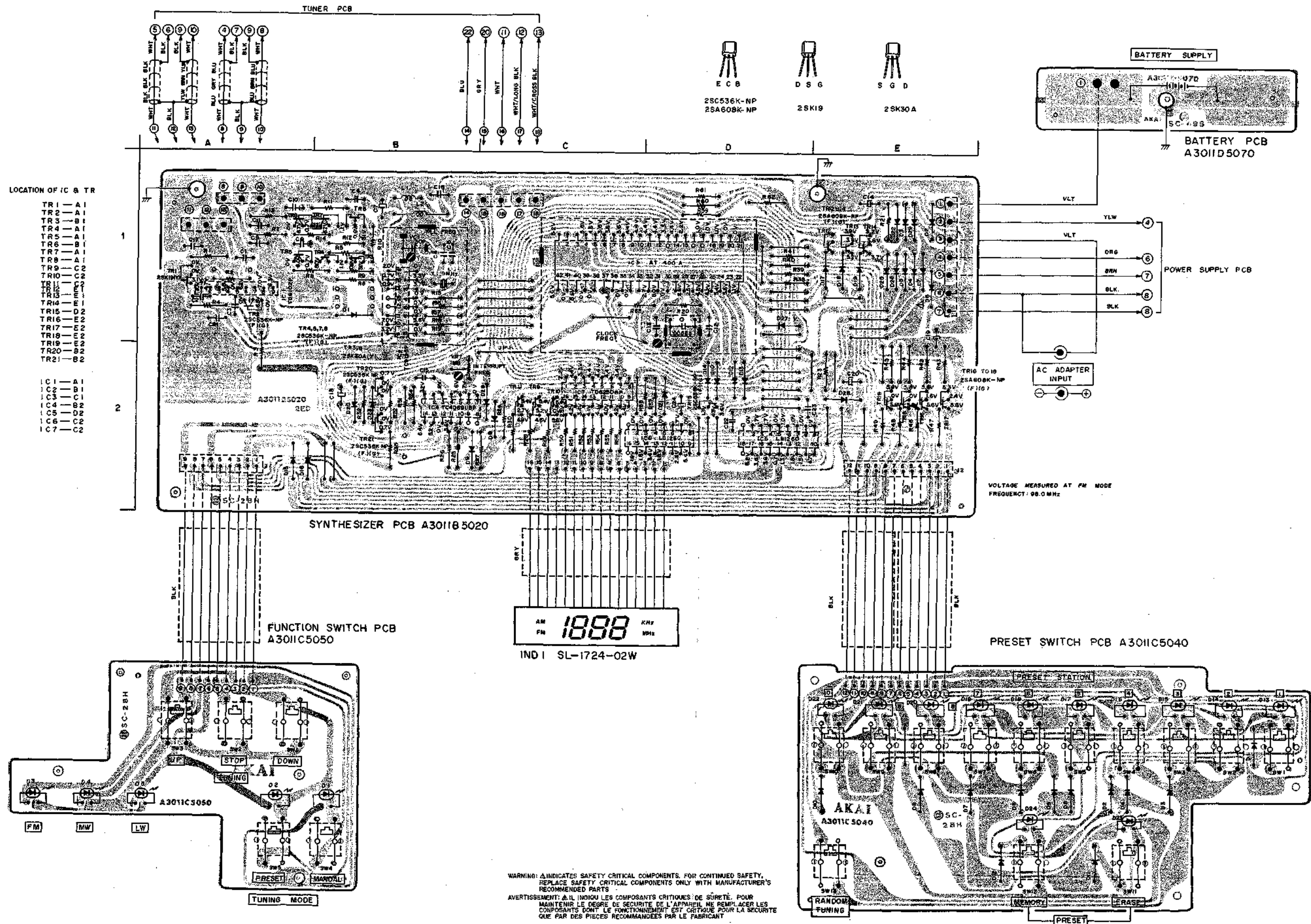

- LOCATION OF IC & TR
- TR1 - A1
 - TR2 - B1
 - TR3 - B1
 - TR4 - A1
 - TR5 - A1
 - TR6 - B1
 - TR7 - A1
 - TR8 - A1
 - TR9 - C2
 - TR10 - C2
 - TR11 - C2
 - TR12 - C2
 - TR13 - E1
 - TR14 - E1
 - TR15 - D2
 - TR16 - E2
 - TR17 - E2
 - TR18 - C2
 - TR19 - E2
 - TR20 - B2
 - TR21 - B2
 - TR22 - B2
- IC1 - A1
 - IC2 - B1
 - IC3 - C1
 - IC4 - B2
 - IC5 - D2
 - IC6 - C2
 - IC7 - C2

AM 1888 kHz
 FM
 IND 1 SL-1724-02W

WARNING: Δ INDICATES SAFETY CRITICAL COMPONENTS. FOR CONTINUED SAFETY, REPLACE SAFETY CRITICAL COMPONENTS ONLY WITH MANUFACTURER'S RECOMMENDED PARTS.
 AVERTISSEMENT: Δ IL INDIQUE LES COMPOSANTS CRITIQUES DE SÛRETÉ. POUR MAINTENIR LE DEGRÉ DE SÛRETÉ DE L'APPAREIL, NE REMPLACER LES COMPOSANTS DONT LE FONCTIONNEMENT EST CRITIQUE POUR LA SÛRETÉ QUE PAR DES PIÈCES RECOMMANDÉES PAR LE FABRICANT.

3) Power Supply P.C Board A3011B5080

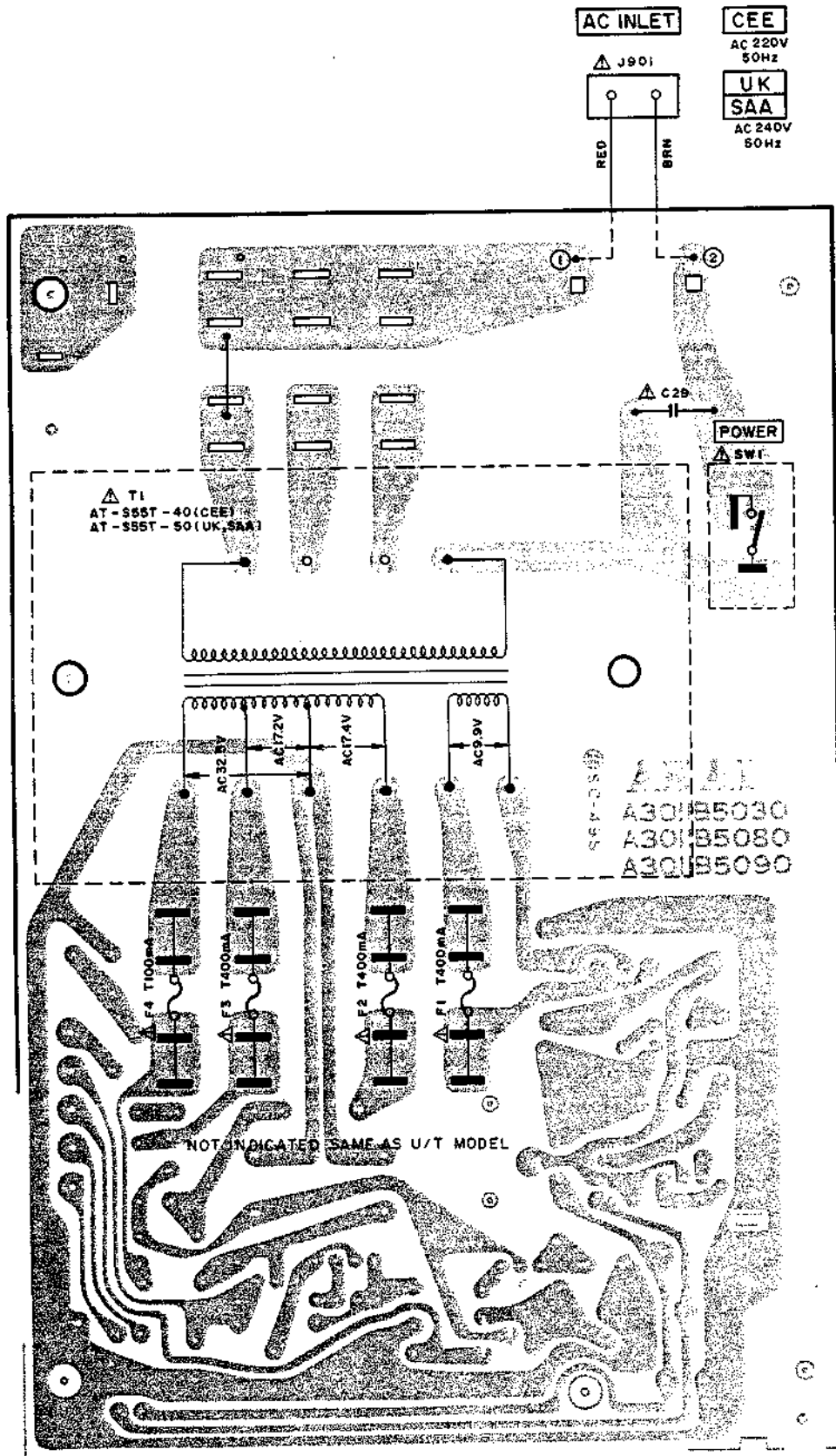

WARNING: Δ INDICATES SAFETY CRITICAL COMPONENTS. FOR CONTINUED SAFETY, REPLACE SAFETY CRITICAL COMPONENTS ONLY WITH MANUFACTURER'S RECOMMENDED PARTS
 AVERTISSEMENT: Δ IL INDIQUE LES COMPOSANTS CRITIQUES DE SÛRETÉ. POUR MAINTENIR LE DEGRÉ DE SÛRETÉ DE L'APPAREIL, NE REMPLACER LES COMPOSANTS DONT LE FONCTIONNEMENT EST CRITIQUE POUR LA SÛRETÉ QUE PAR DES PIÈCES RECOMMANDÉES PAR LE FABRICANT

SECTION 2

SERVICE MANUAL

MODEL AM-U55/J

TABLE OF CONTENTS

I.	SPECIFICATIONS	26
II.	DISMANTLING OF UNIT	27
III.	CONTROLS	28
	1. MODEL AM-U55	28
	2. MODEL AM-U55J	29
IV.	PRINCIPAL PARTS LOCATION	30
	1. MODEL AM-U55	30
	2. MODEL AM-U55J	31
V.	VOLTAGE CONVERSION	32
VI.	ADJUSTMENTS	33
	1. POWER METER SENSITIVITY ADJUSTMENT	34
	2. CENTER OFF-SET VOLTAGE ADJUSTMENT	34
VII.	CLASSIFICATION OF VARIOUS P.C BOARDS	35
	1. P.C BOARD TITLES AND IDENTIFICATION NUMBERS	35
	2. MODEL AM-U55; COMPOSITION OF VARIOUS P.C BOARDS	36
	3. MODEL AM-U55J; COMPOSITION OF VARIOUS P.C BOARDS	41

For basic adjustments, measuring methods, and operating principles, refer to GENERAL TECHNICAL MANUAL.

I. SPECIFICATIONS

POWER AMPLIFIER SECTION

RATED POWER OUTPUT (2-Channel Driven)	55 watts per channel, minimum RMS, at 8 ohms from 20Hz to 20,000Hz with no more than 0.05% total harmonic distortion.
POWER BANDWIDTH	5Hz to 60kHz/8 ohms (Total Harmonic Distortion: 0.07%)
SIGNAL TO NOISE RATIO (IHF) PHONO AUX	Better than 85dB Better than 102dB
RESIDUAL NOISE	Less than 180 μ V at 8 ohms
CHANNEL SEPARATION (IHF)	Better than 60dB at 1,000 Hz
DAMPING FACTOR	More than 60 (1kHz, 8 ohms)
OUTPUT SPEAKERS HEADPHONES	A, B (4 to 16 ohms)/A+B (8 to 16 ohms) 4 to 16 ohms

PRE AMPLIFIER SECTION

INPUT SENSITIVITY/IMPEDANCE PHONO AUX TUNER TAPE MONITOR	3mV/47 kohms 150mV/100 kohms 150mV/100 kohms 150mV/100 kohms
OUTPUT LEVEL/IMPEDANCE TAPE REC PRE OUT	150mV 1V/600 ohms
FREQUENCY RESPONSE PHONO (RIAA Deviation) TUNER, AUX, TAPE	20Hz to 20kHz \pm 0.3dB 6Hz to 100kHz +0dB, -3dB
TONE CONTROL BASS TREBLE	\pm 8dB at 100Hz \pm 8dB at 10kHz
LOUDNESS CONTROL	+10dB at 100Hz, +6dB at 10kHz (Volume control set at -30dB position)
LOW CUT FILTER	-6dB/oct. at 18Hz.

MISCELLANEOUS

POWER REQUIREMENTS	100V, 50/60Hz for Japan 120V, 60Hz for U.S. A. and Canada 220V, 50Hz for Europe except UK 240V, 50Hz for UK and Australia 110V/220V/240V, 50/60Hz internally switchable for other countries
POWER CONSUMPTION	U/T Model: 200 Watts, JPN Model: 130 Watts
DIMENSIONS	JPN Model: 440(W) x 105(H) x 323(D) mm Other Models: 440(W) x 105(H) x 383(D) mm (17.3 x 4.1 x 15.1 inches)
WEIGHT	JPN Model: 8.6 kg Other Models: 10.1 kg (22.2 lbs)

* For improvement purposes, specifications and design are subject to change without notice.

II. DISMANTLING OF UNIT

AM-U55/J

In case of trouble, etc. necessitating dismantling, please dismantle in the order shown in the photographs. Reassemble in reverse order.

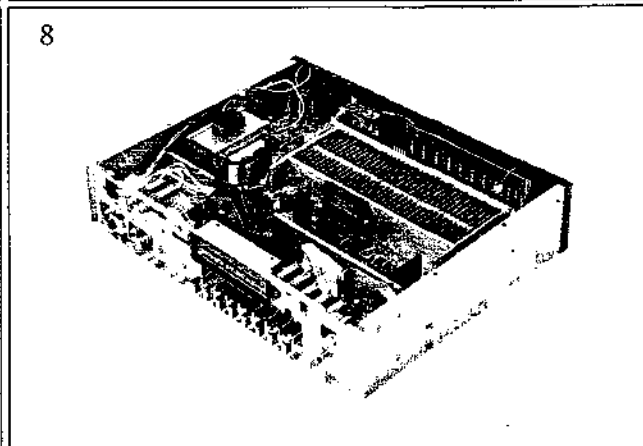
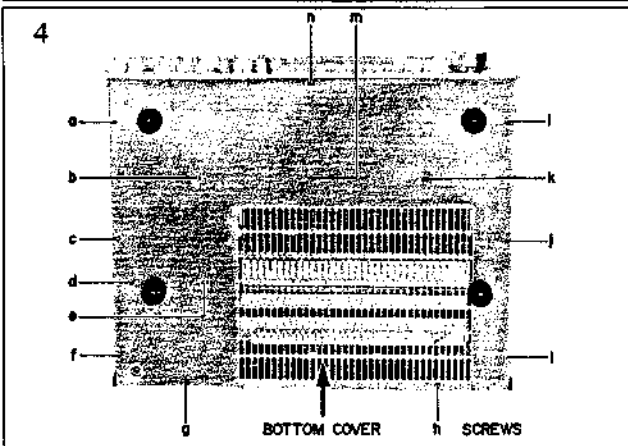
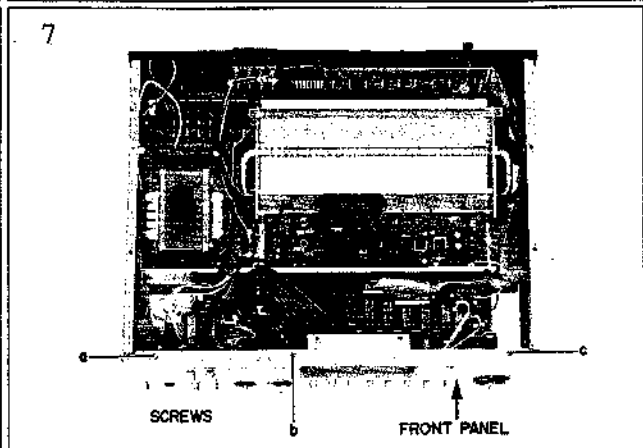
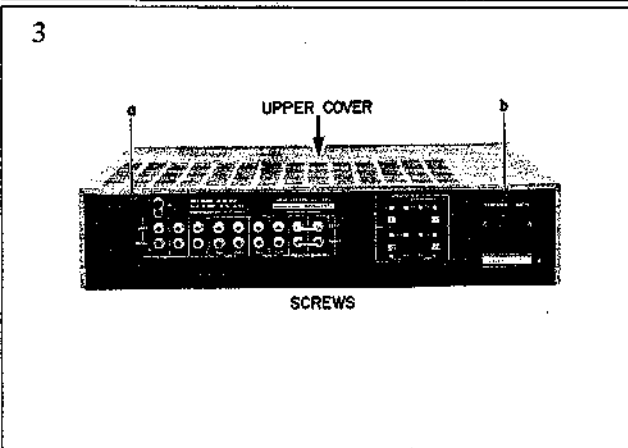
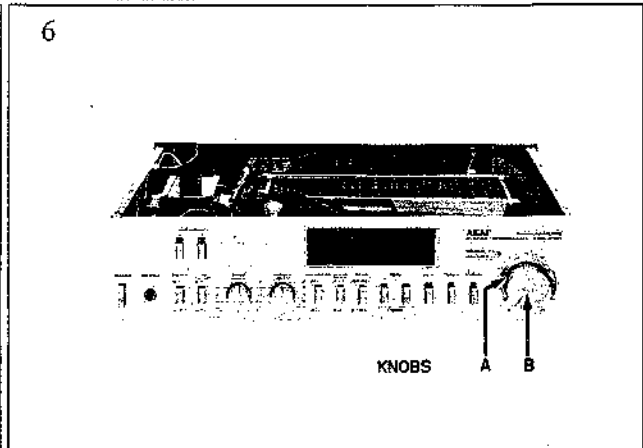
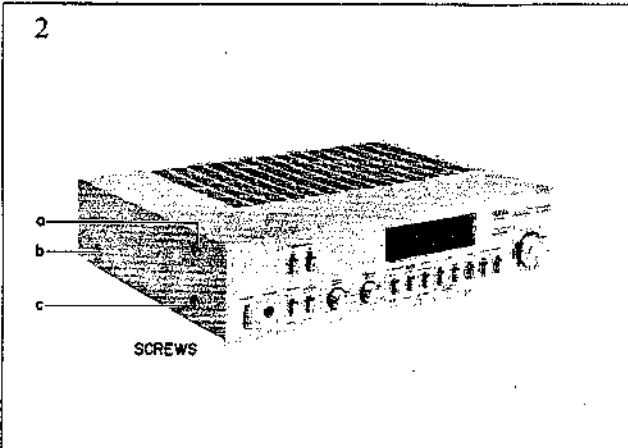
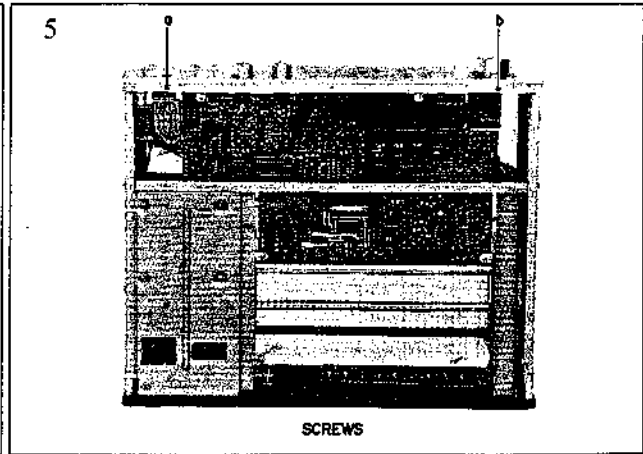
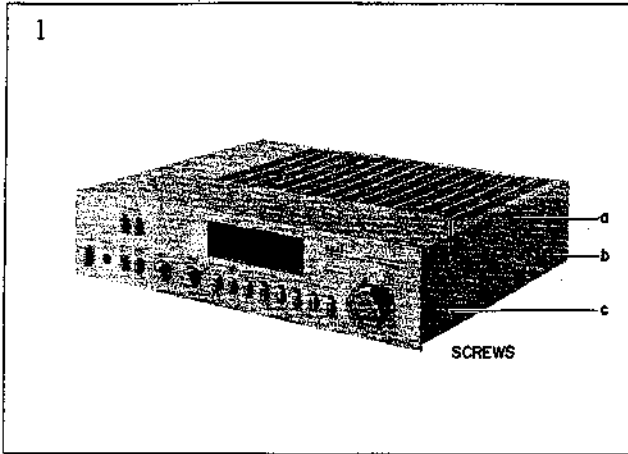

III. CONTROLS

1. MODEL AM-U55

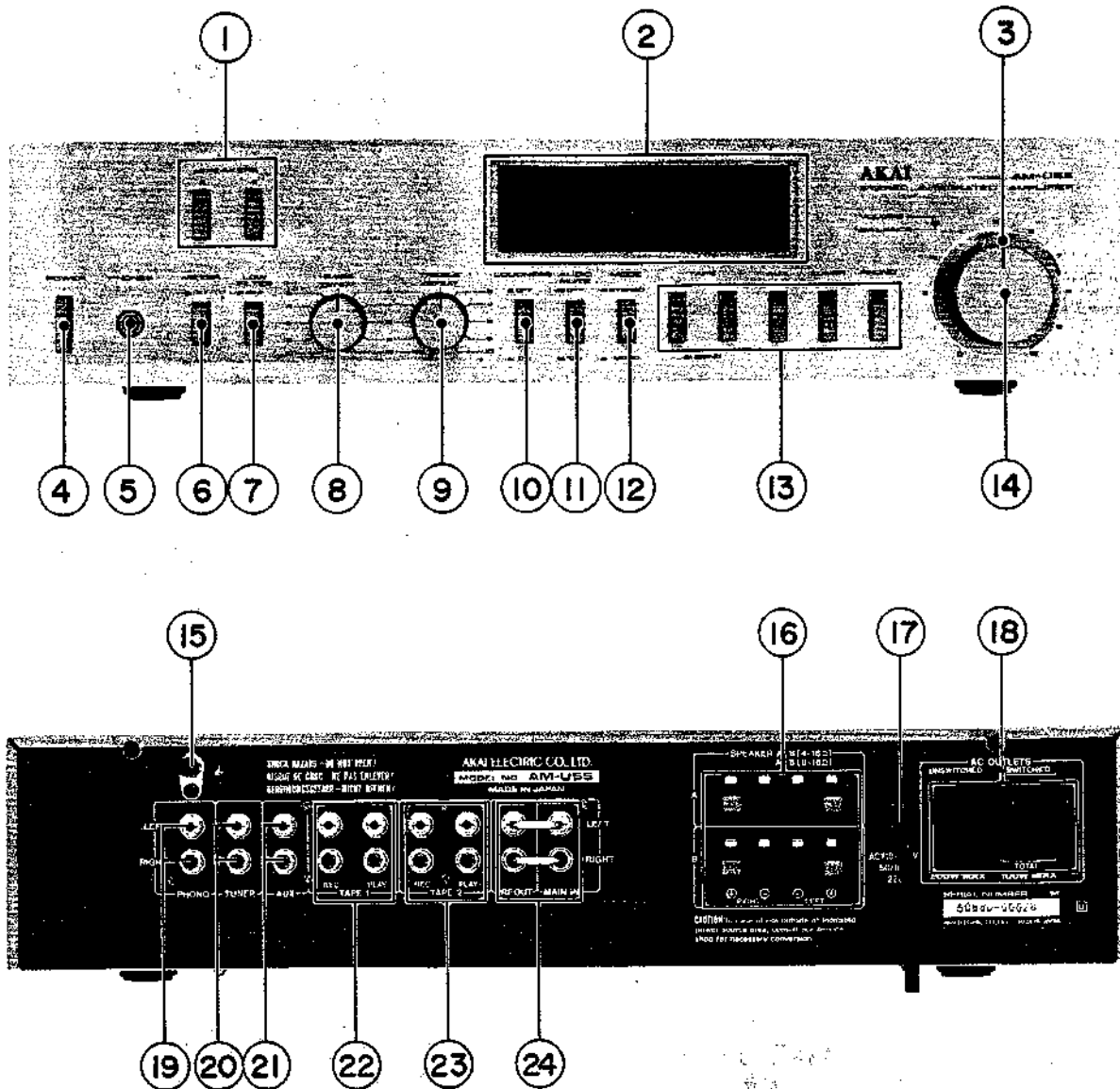



Fig. 1. Controls (AM-U55)

- | | |
|------------------------------------|---|
| 1. SPEAKER SWITCHES AND INDICATORS | 13. INPUT SELECTOR SWITCHES AND INDICATORS |
| 2. LED BAR METER | 14. VOLUME CONTROL |
| 3. STEREO BALANCE CONTROL | 15. GROUND TERMINAL () |
| 4. POWER SWITCH | 16. A AND B SPEAKER SYSTEM TERMINALS |
| 5. HEADPHONE JACK (PHONES) | 17. AC CORD (CEE, UK, SAA: AC INLET) |
| 6. METER SELECTOR | 18. AC OUTLETS (U/T, CSA, AAL ONLY) |
| 7. LOW FILTER SWITCH | 19. PHONO JACKS |
| 8. BASS CONTROL | 20. TUNER JACKS |
| 9. TREBLE CONTROL | 21. AUX JACKS |
| 10. LOUDNESS SWITCH | 22. TAPE 1 SYSTEM RECORDING (REC)/PLAY JACKS |
| 11. AUDIO MUTE SWITCH | 23. TAPE 2 SYSTEM REC/PLAY JACKS |
| 12. MODE SELECTOR | 24. PRE OUT AND MAIN IN JACKS |

2. MODEL AM-U55J

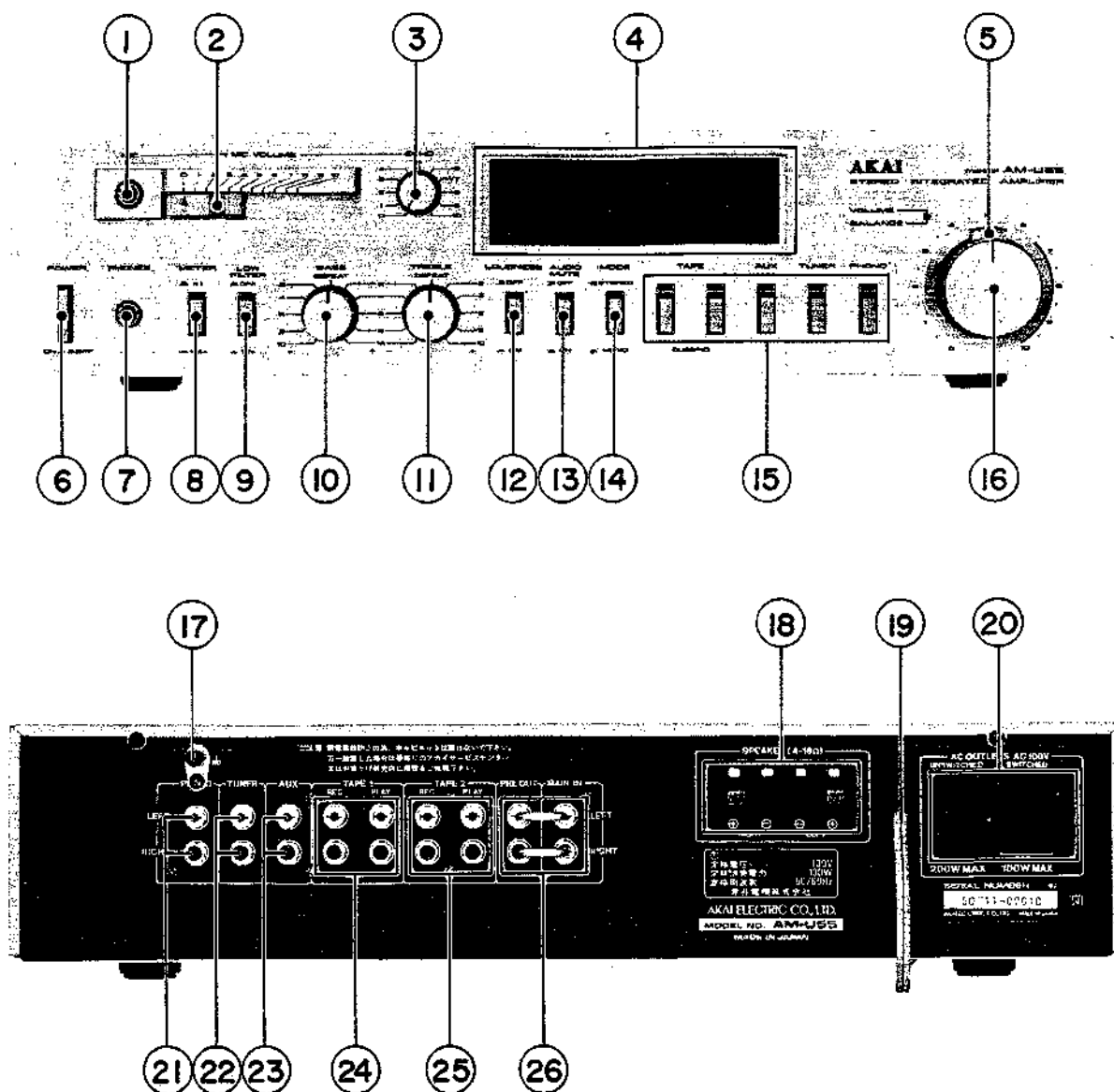

Fig. 2 Controls (AM-U55J)

- | | |
|----------------------------|--|
| 1. MIC JACK | 14. MODE SELECTOR |
| 2. MIC VOLUME CONTROL | 15. INPUT SELECTOR SWITCHES AND INDICATORS |
| 3. ECHO CONTROL | 16. VOLUME CONTROL |
| 4. LED BAR METER | 17. GROUND TERMINAL (\perp) |
| 5. STEREO BALANCE CONTROL | 18. SPEAKER TERMINALS |
| 6. POWER SWITCH | 19. AC CORD |
| 7. HEADPHONE JACK (PHONES) | 20. AC OUTLETS |
| 8. METER SELECTOR | 21. PHONO JACKS |
| 9. LOW FILTER SWITCH | 22. TUNER JACKS |
| 10. BASS CONTROL | 23. AUX JACKS |
| 11. TREBLE CONTROL | 24. TAPE 1 SYSTEM REC/PLAY JACKS |
| 12. LOUDNESS SWITCH | 25. TAPE 2 SYSTEM REC/PLAY JACKS |
| 13. AUDIO MUTE SWITCH | 26. PRE OUT AND MAIN IN JACKS |

IV. PRINCIPAL PARTS LOCATION

1. MODEL AM-U55

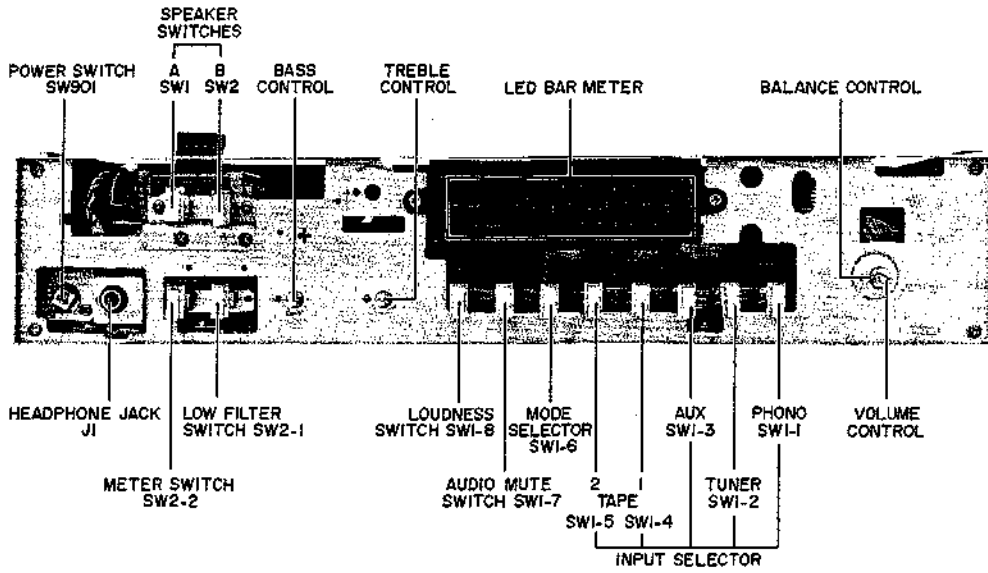

Fig. 3 Front View

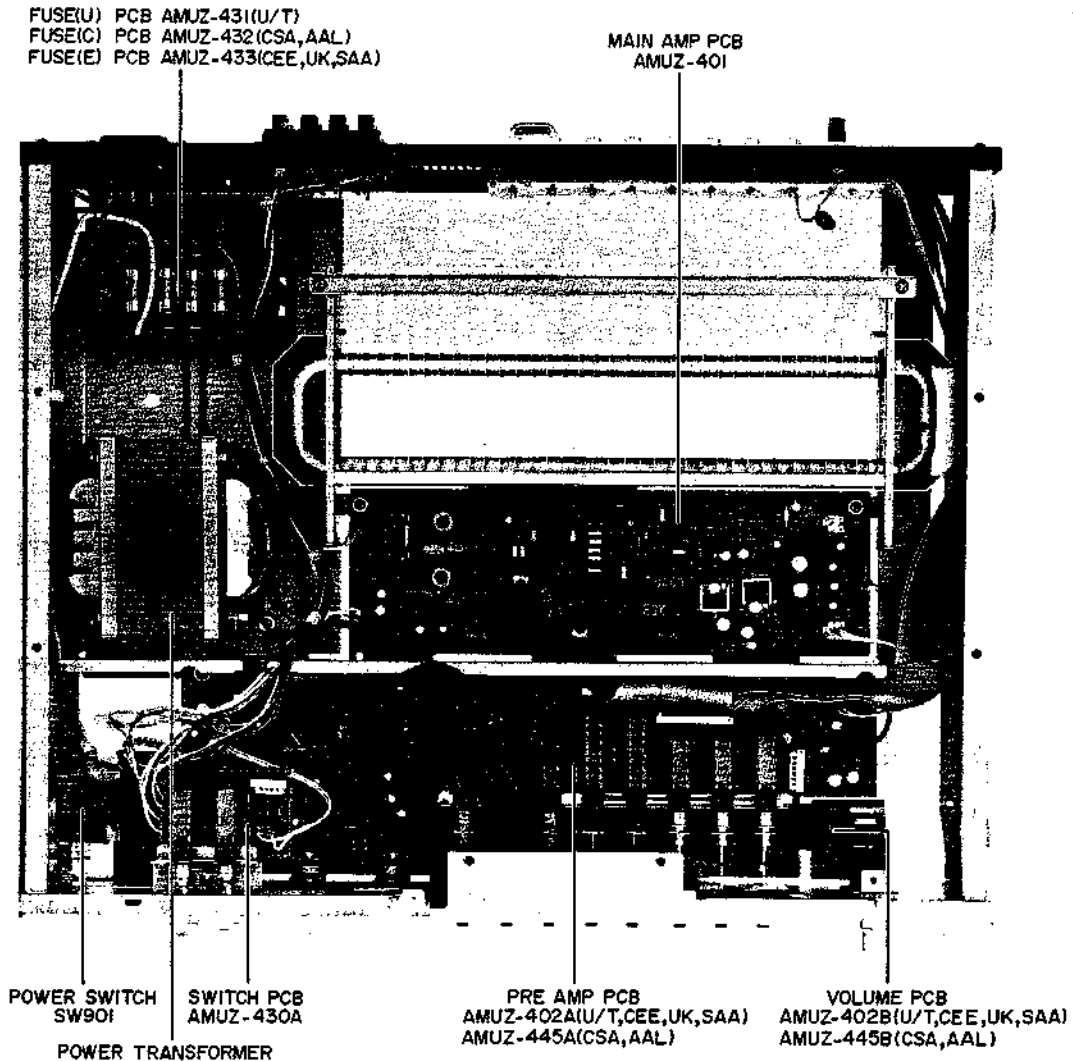

Fig. 4 Top View

2. MODEL AM-U55J

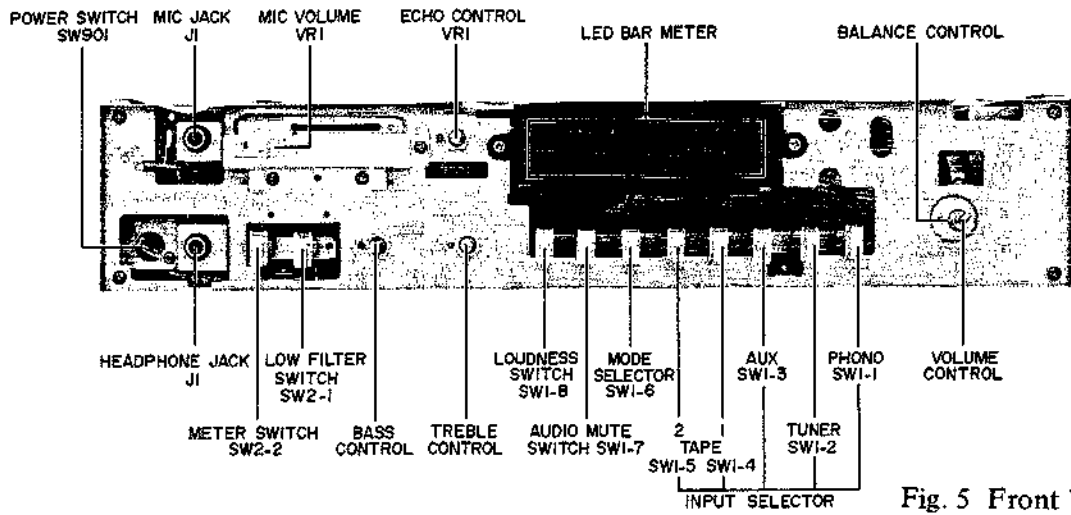

Fig. 5 Front View

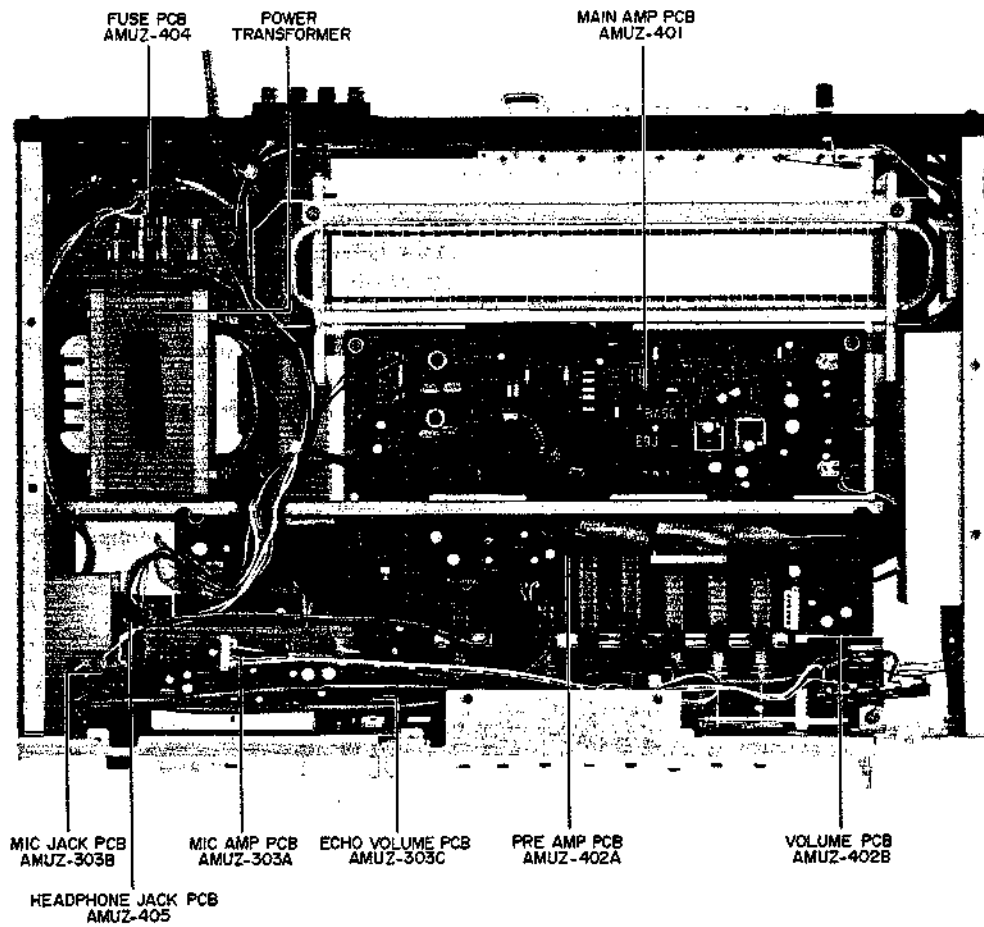

Fig. 6 Top View

V. VOLTAGE CONVERSION

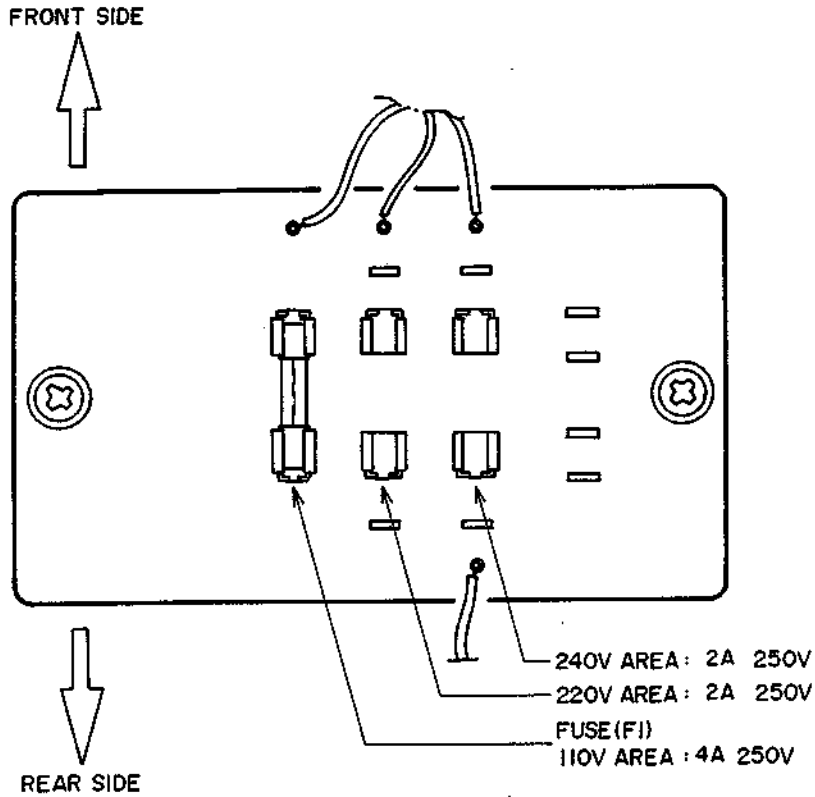

Fig. 7 Voltage Conversion (U/T Model Only)

Models for Canada, U.S.A., Europe, UK, Australia (AM-U55) and Japan (AM-U55J) are not equipped with this facility.

Each machine is preset at the factory according to destination but some machines can be set to 110V, 220V or 240V as required.

If voltage change is necessary, this can be accomplished as follows.

- 1) Disconnect AC Power Cord.
- 2) Loosen holding screws and remove upper cover.
- 3) Remove existing Line Voltage Fuse and insert the required Line Voltage Fuse into the proper fuse holder.

VI. ADJUSTMENTS

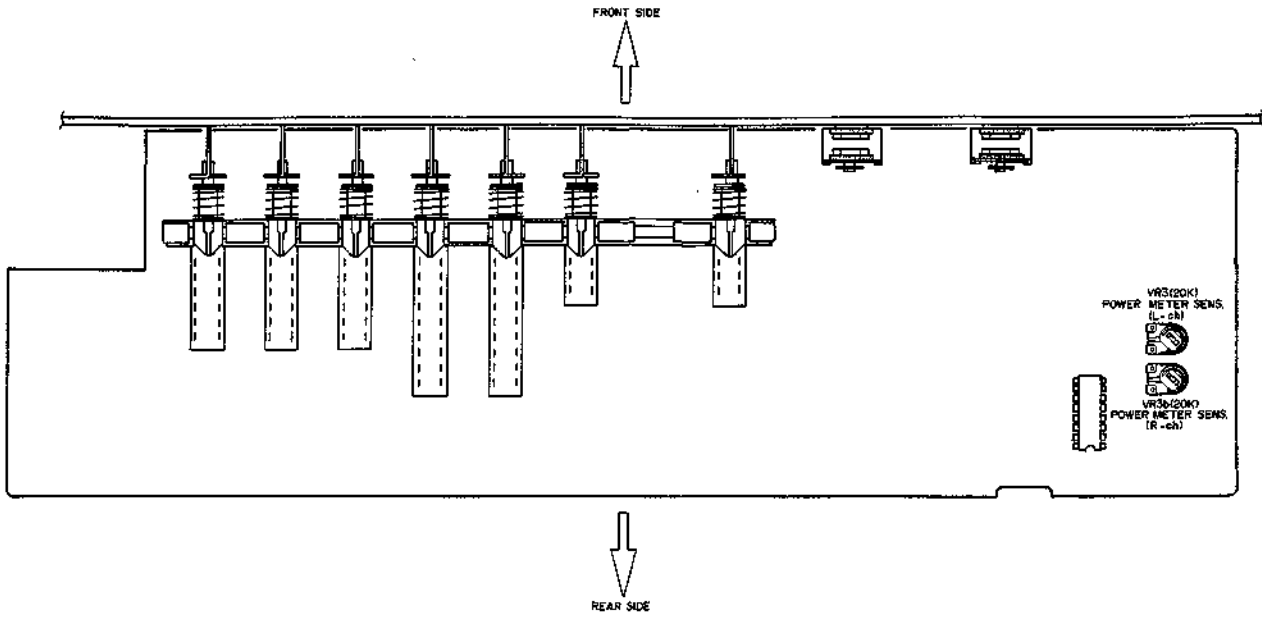

Fig. 8 Pre Amp P.C Board

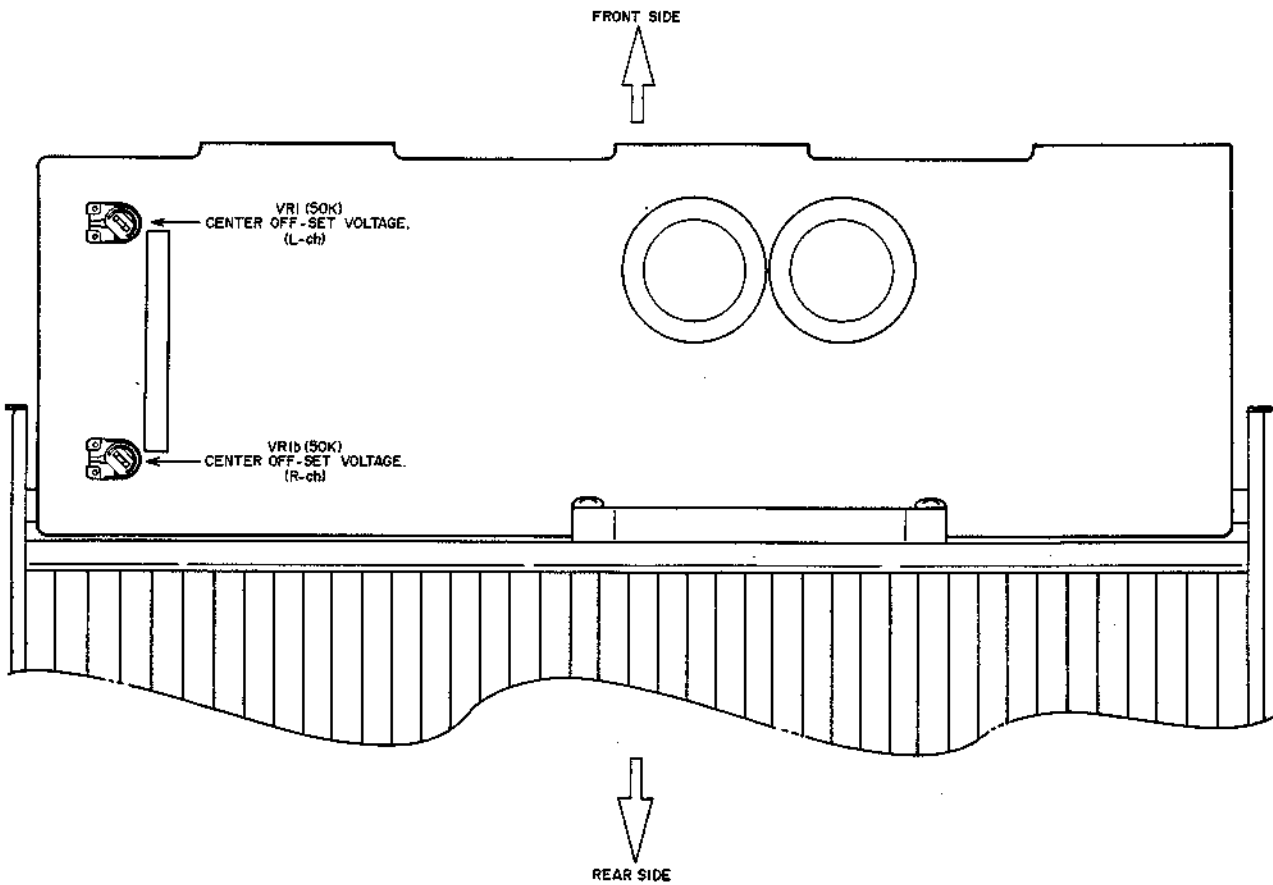

Fig. 9 Main Amp P.C Board

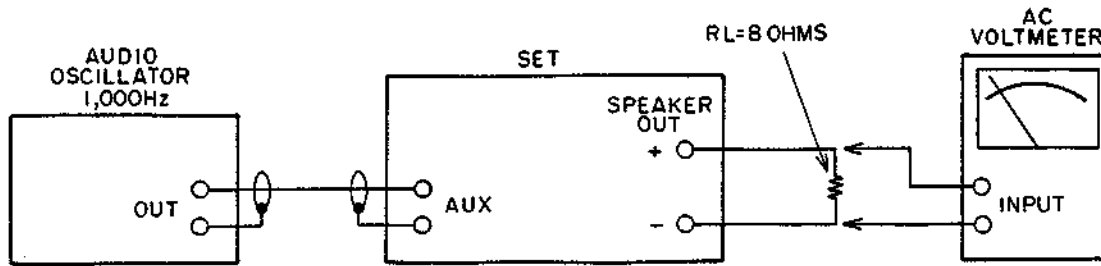

Fig. 10 Instrument Connections for Power Meter Sensitivity Adjustment

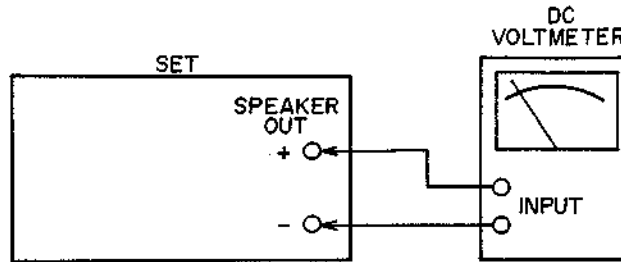

Fig. 11 Instrument Connections for Center Off-set Voltage Adjustment

1. POWER METER SENSITIVITY

ADJUSTMENT (Refer to Figs. 8, 10)

Set the Meter Range switch to "x1", and connect the load resistor ($RL=8$ ohms) to speaker terminals. Then apply a 1kHz signal to the AUX input terminals, adjusting the input level so as to obtain the rated output voltage level (12.6V) at both ends of the load resistor.

Adjust VR3 (left channel) and VR3b (right channel) on the Pre Amp P.C Board so that the 7th LED (20 Watts) in the Power Meter light up.

2. CENTER OFF-SET VOLTAGE

ADJUSTMENT (Refer to Figs. 9, 11)

Connect the DC Voltmeter or Digital Voltmeter to the speaker terminals. Adjust the VR1 (left channel) and VR1b (right channel) on the Main Amp P.C Board, so that the Voltmeter reads $0 \pm 50mV$.

VII. CLASSIFICATION OF VARIOUS P.C BOARDS

AM-U55/J

1. P.C BOARD TITLES AND IDENTIFICATION NUMBERS

1) Model AM-U55

P.C Board Title	P.C Board Number	Remarks
Main Amp P.C Board	AMUZ-401	
Pre Amp P.C Board	AMUZ-402A	U/T, CEE, UK, SAA
Pre Amp P.C Board	AMUZ-445A	CSA, AAL
Volume P.C Board	AMUZ-402B	U/T, CEE, UK, SAA
Volume P.C Board	AMUZ-445B	CSA, AAL
Pin Jack P.C Board	AMUZ-403	
Headphone Jack P.C Board	AMUZ-405	
LED (A) P.C Board	AMUZ-406A	
LED (B) P.C Board	AMUZ-406B	
Switch P.C Board	AMUZ-430A	
LED (C) P.C Board	AMUZ-430B	
Fuse (U) P.C Board	AMUZ-431	U/T
Fuse (C) P.C Board	AMUZ-432	CSA, AAL
Fuse (E) P.C Board	AMUZ-433	CEE, UK, SAA

2) Model AM-U55J

P.C Board Title	P.C Board Number	Remarks
Main Amp P.C Board	AMUZ-401	
Pre Amp P.C Board	AMUZ-402A	
Volume P.C Board	AMUZ-402B	
Pin Jack P.C Board	AMUZ-403	
Fuse P.C Board	AMUZ-404	
Headphone Jack P.C Board	AMUZ-405	
LED (A) P.C Board	AMUZ-406A	
LED (B) P.C Board	AMUZ-406B	
Mic Amp P.C Board	AMUZ-303A	
Mic Jack P.C Board	AMUZ-303B	
Echo Volume P.C Board	AMUZ-303C	

2. MODEL AM-U55; COMPOSITION OF VARIOUS P.C BOARDS

1) Main Amp P.C Board AMUZ-401 (2ED)

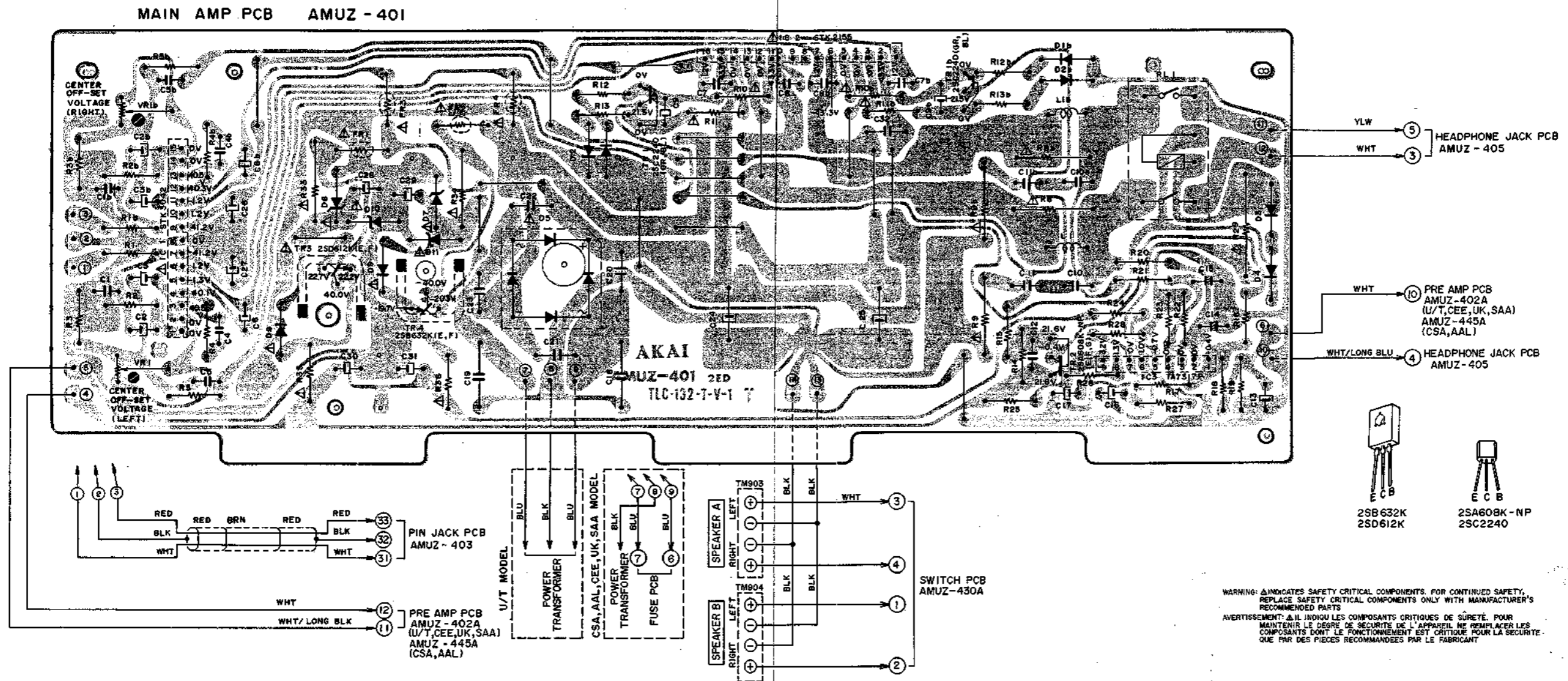

2) Pre Amp P.C Board AMUZ-402A (2ED) (U/T, CEE, UK, SAA), AMUZ-445A (2ED) (CSA, AAL), Volume P.C Board AMUZ-402B (U/T, CEE, UK, SAA), AMUZ-445B (CSA, AAL), Headphone Jack P.C Board AMUZ-405, LED (A) P.C Board AMUZ-406A and LED (B) P.C Board AMUZ-406B

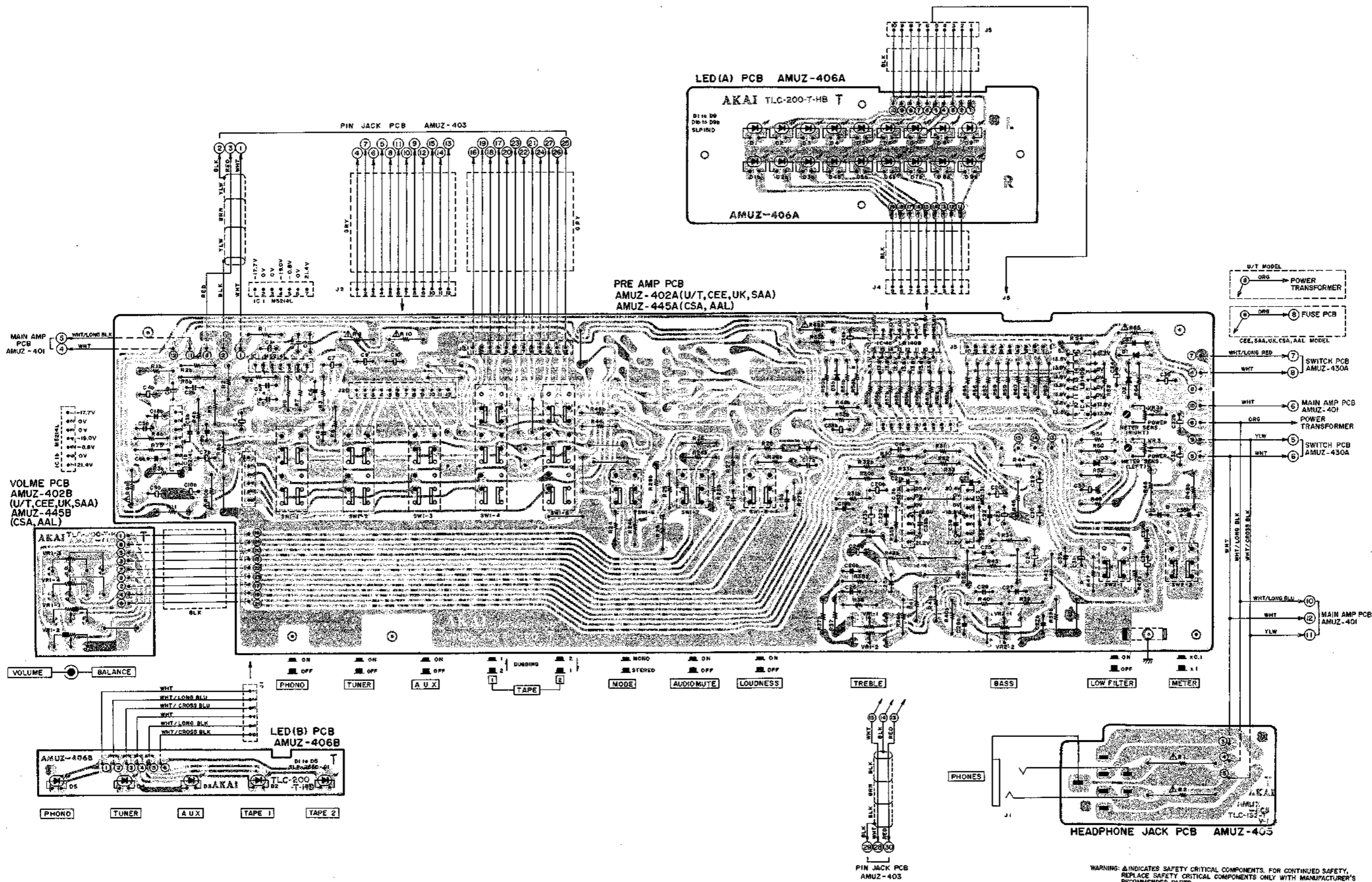

WARNING: & INDICATES SAFETY CRITICAL COMPONENTS. FOR CONTINUED SAFETY, REPLACE SAFETY CRITICAL COMPONENTS ONLY WITH MANUFACTURER'S RECOMMENDED PARTS
 AVERTISSEMENT: & IL INDIQUE LES COMPOSANTS CRITIQUES DE SÛRETÉ. POUR MAINTENIR LE DEGRÉ DE SÛRETÉ DE L'APPAREIL, NE REMPLACER LES COMPOSANTS DONT LE FONCTIONNEMENT EST CRITIQUE POUR LA SÛRETÉ, QUE PAR DES PIÈCES RECOMMANDÉES PAR LE FABRICANT

3) Pin Jack P.C Board AMUZ-403

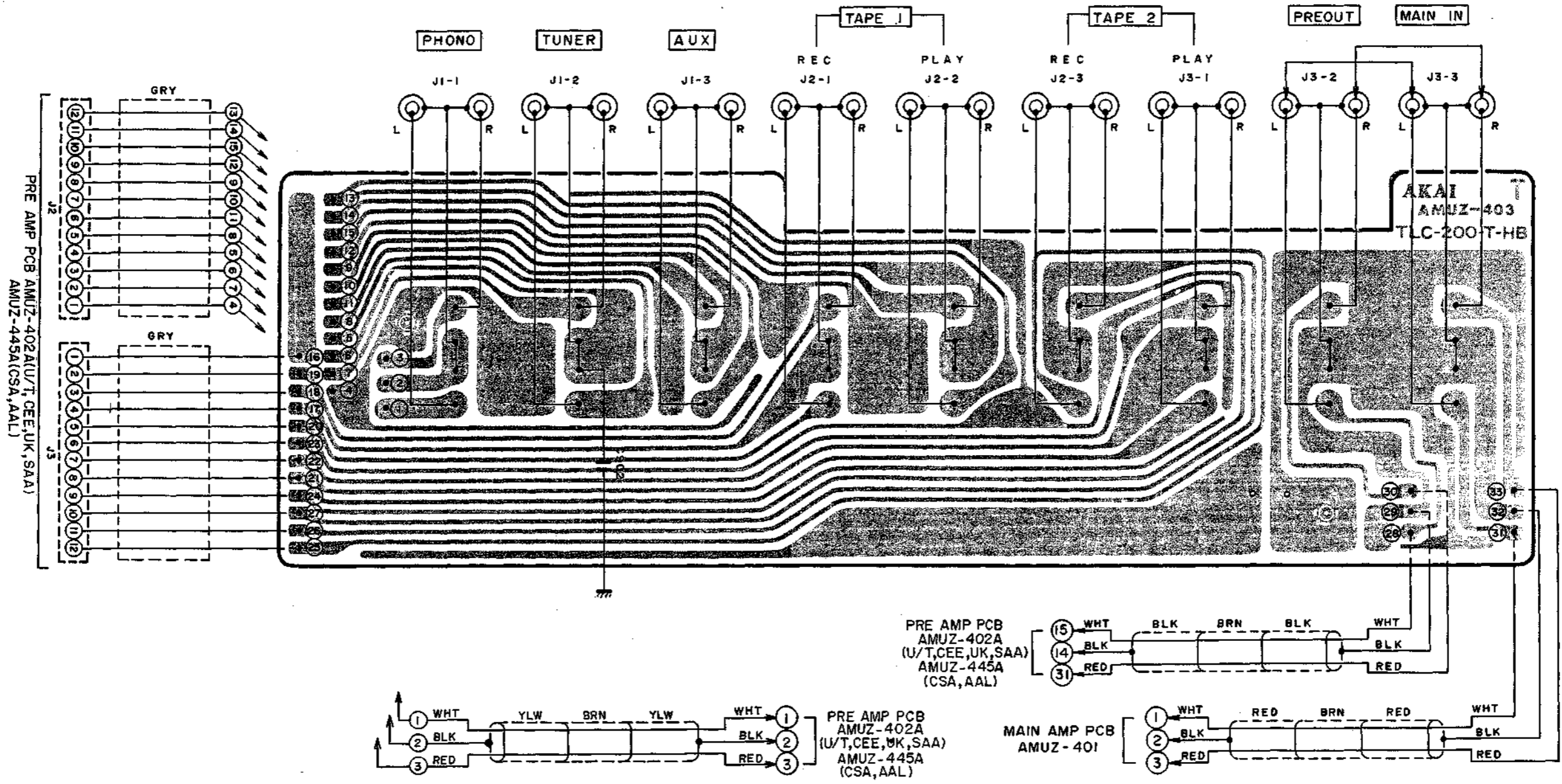

4) Switch P.C Board AMUZ-430A and LED (C) P.C Board AMUZ-430B

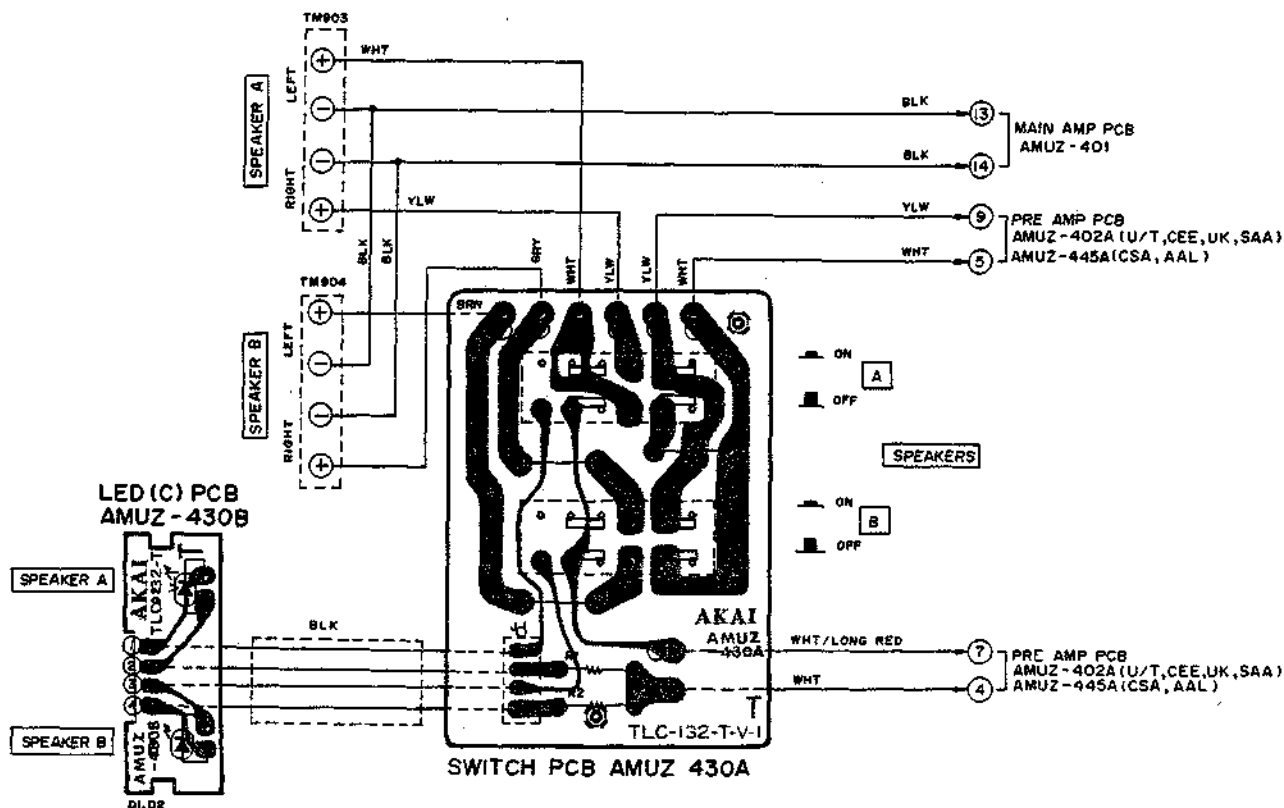

5) Fuse (U) P.C Board AMUZ-431 (U/T)

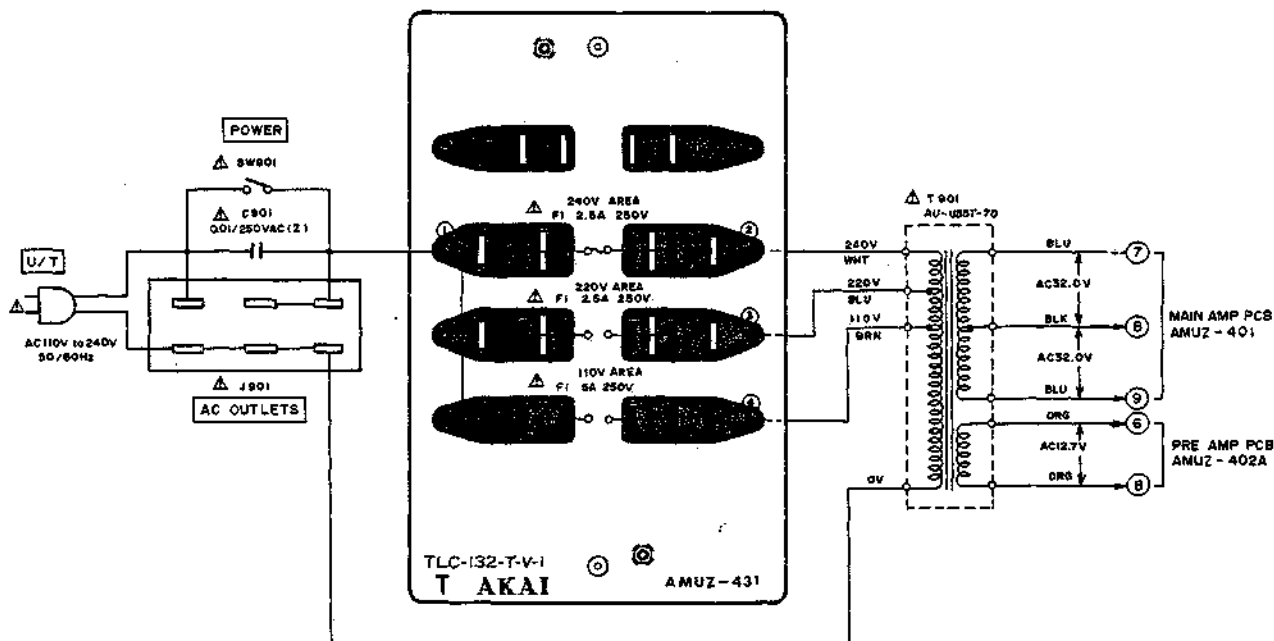

WARNING: Δ INDICATES SAFETY CRITICAL COMPONENTS. FOR CONTINUED SAFETY, REPLACE SAFETY CRITICAL COMPONENTS ONLY WITH MANUFACTURER'S RECOMMENDED PARTS
 AVERTISSEMENT: Δ IL INDIQUE LES COMPOSANTS CRITIQUES DE SÛRETÉ. POUR MAINTENIR LE DEGRÉ DE SÛRETÉ DE L'APPAREIL, NE REMPLACER LES COMPOSANTS DONT LE FONCTIONNEMENT EST CRITIQUE POUR LA SÛRETÉ QUE PAR DES PIÈCES RECOMMANDÉES PAR LE FABRICANT

6) Fuse (C) P.C Board AMUZ-432 (CSA, AAL)

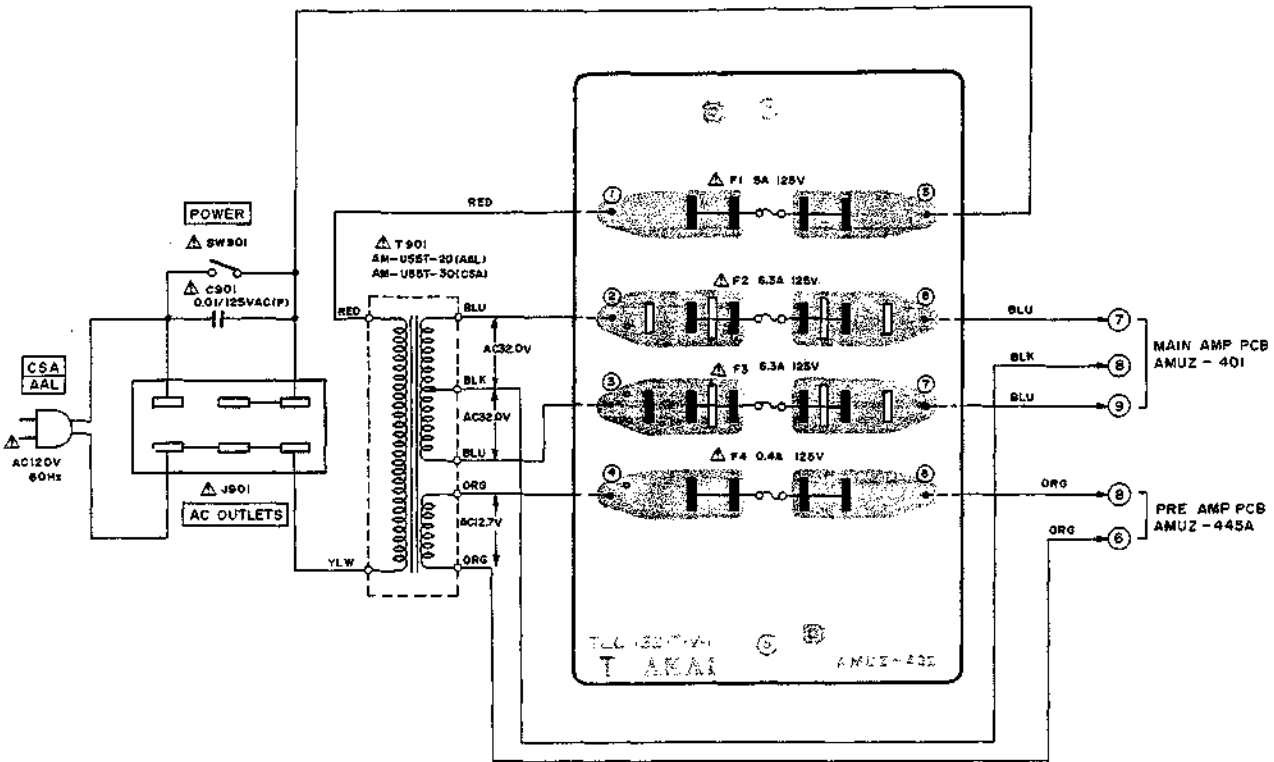

7) Fuse (E) P.C Board AMUZ-433 (CEE, UK, SAA)

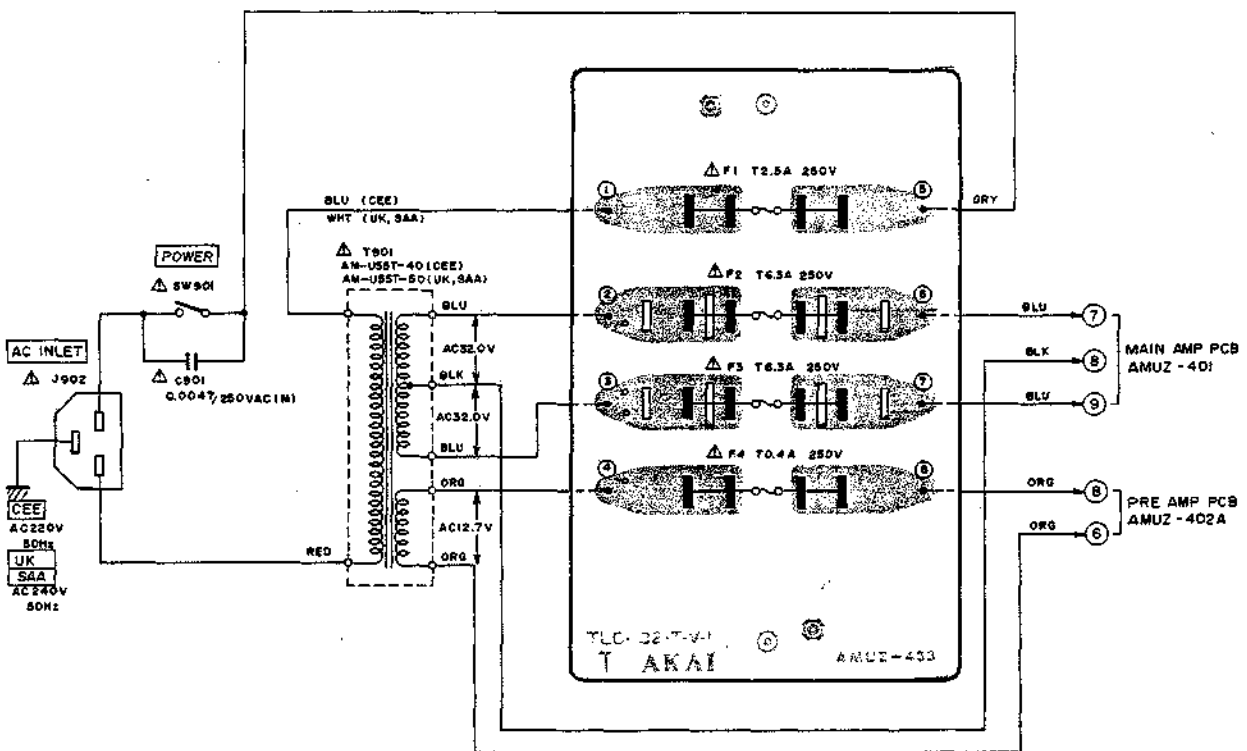

WARNING: Δ INDICATES SAFETY CRITICAL COMPONENTS. FOR CONTINUED SAFETY, REPLACE SAFETY CRITICAL COMPONENTS ONLY WITH MANUFACTURER'S RECOMMENDED PARTS
 AVERTISSEMENT: Δ IL INDIQUE LES COMPOSANTS CRITIQUES DE SÛRETÉ. POUR MAINTENIR LE DEGRÉ DE SÛRETÉ DE L'APPAREIL, NE REMPLACER LES COMPOSANTS DONT LE FONCTIONNEMENT EST CRITIQUE POUR LA SÛRETÉ QUE PAR DES PIÈCES RECOMMANDÉES PAR LE FABRICANT

3. MODEL AM-U55J; COMPOSITION OF VARIOUS P.C BOARDS

1) Main Amp P.C Board AMUZ-401

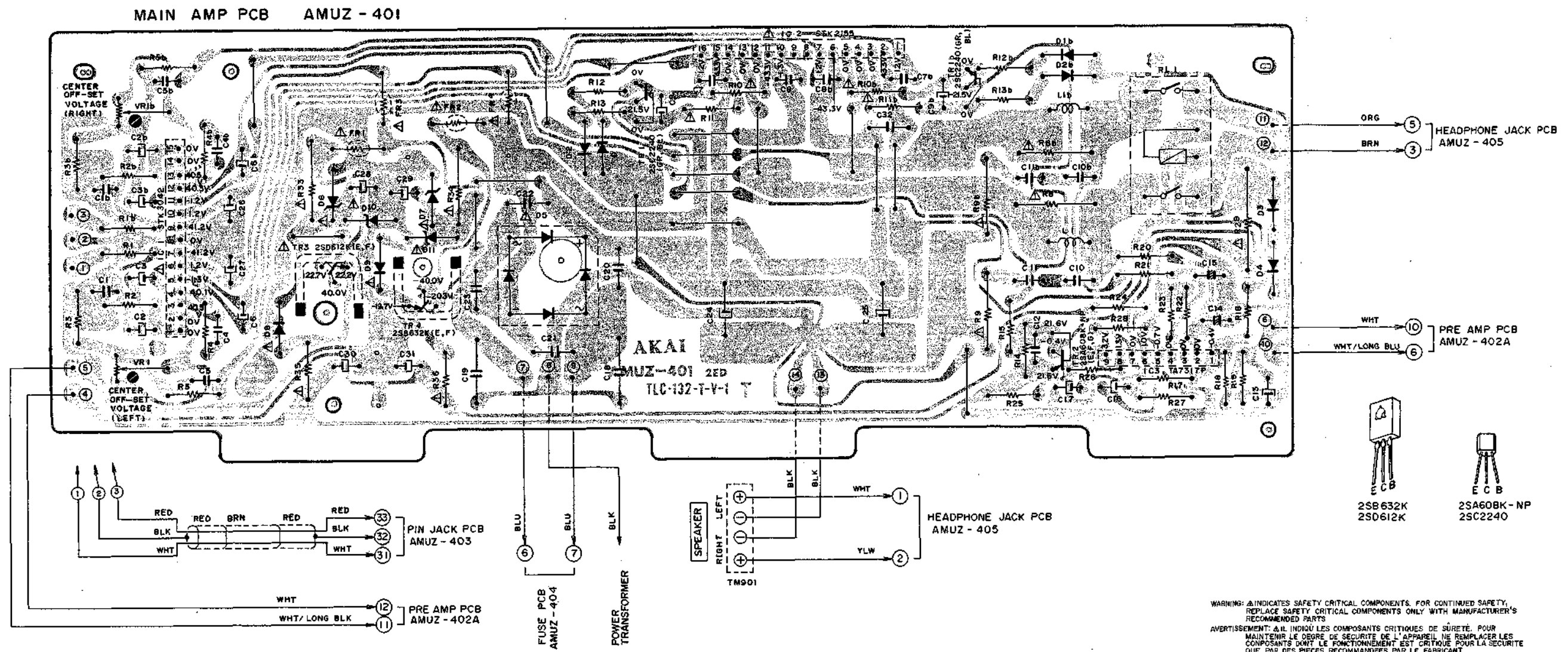

2) Pre Amp P.C Board AMUZ-402A (2ED), Volume P.C Board AMUZ-402B, Headphone Jack P.C Board AMUZ-405, LED (A) P.C Board AMUZ-406A and LED (B) P.C Board AMUZ-406B

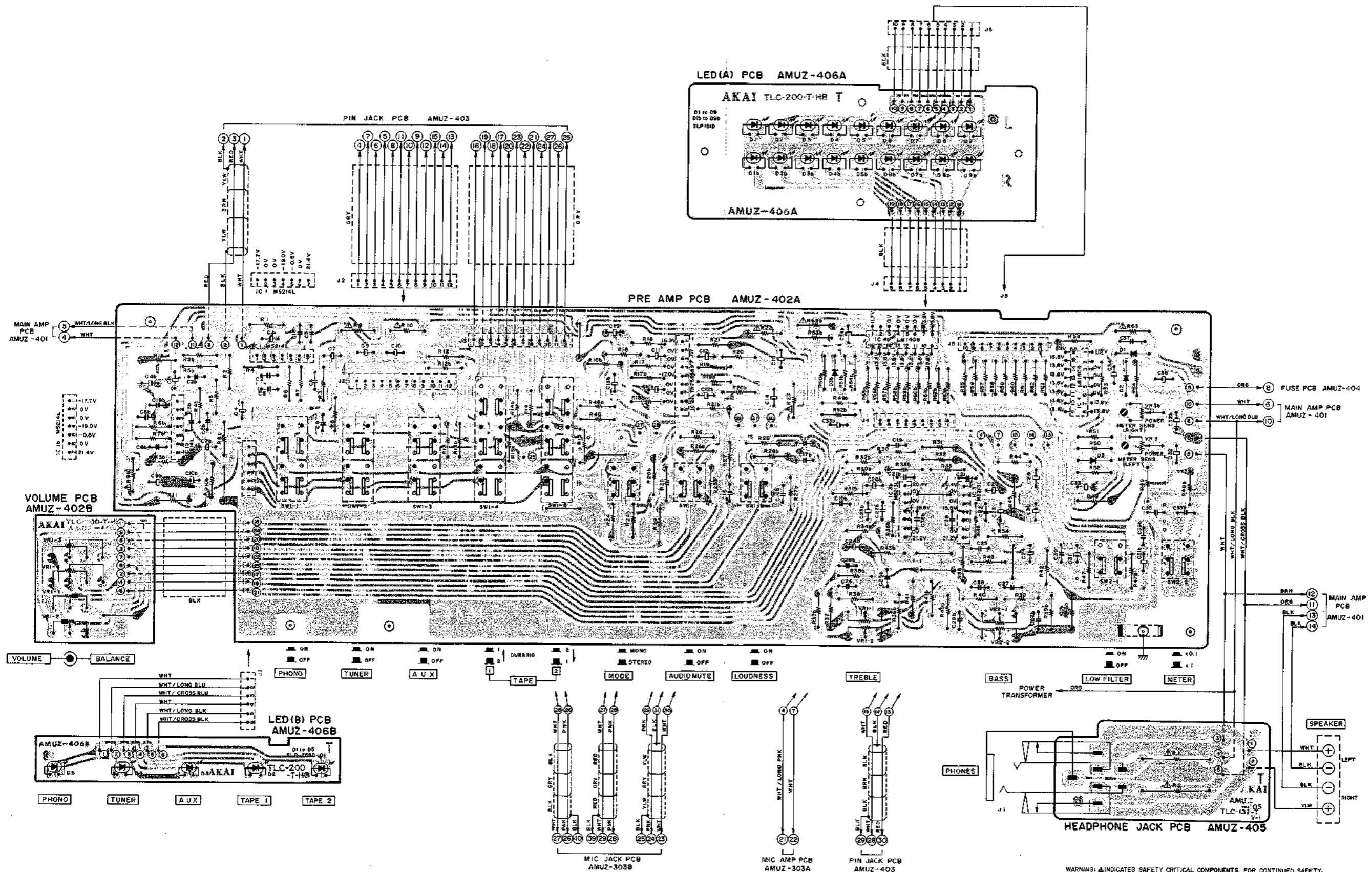

WARNING: Δ INDICATES SAFETY CRITICAL COMPONENTS. FOR CONTINUED SAFETY, REPLACE SAFETY CRITICAL COMPONENTS ONLY WITH MANUFACTURER'S RECOMMENDED PARTS.
 AVERTISSEMENT: Δ IL INDIQUE LES COMPOSANTS CRITIQUES DE SÛRETÉ. POUR MAINTENIR LE DEGRÉ DE SÛRETÉ DE L'APPAREIL, NE REMPLACER LES COMPOSANTS DONT LE FONCTIONNEMENT EST CRITIQUE POUR LA SÛRETÉ QUE PAR DES PIÈCES RECOMMANDÉES PAR LE FABRICANT.

3) Pin Jack P.C Board AMUZ-403

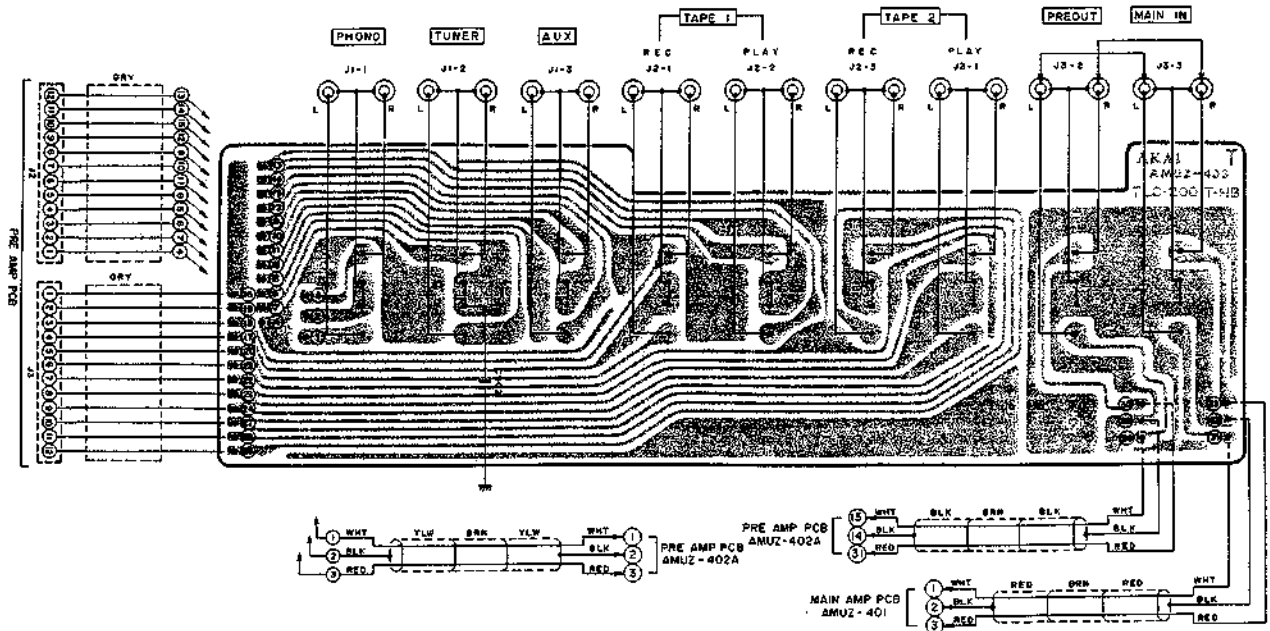

4) Mic Amp P.C Board AMUZ-303A, Mic Jack P.C Board AMUZ-303B and Echo Volume P.C Board AMUZ-303C

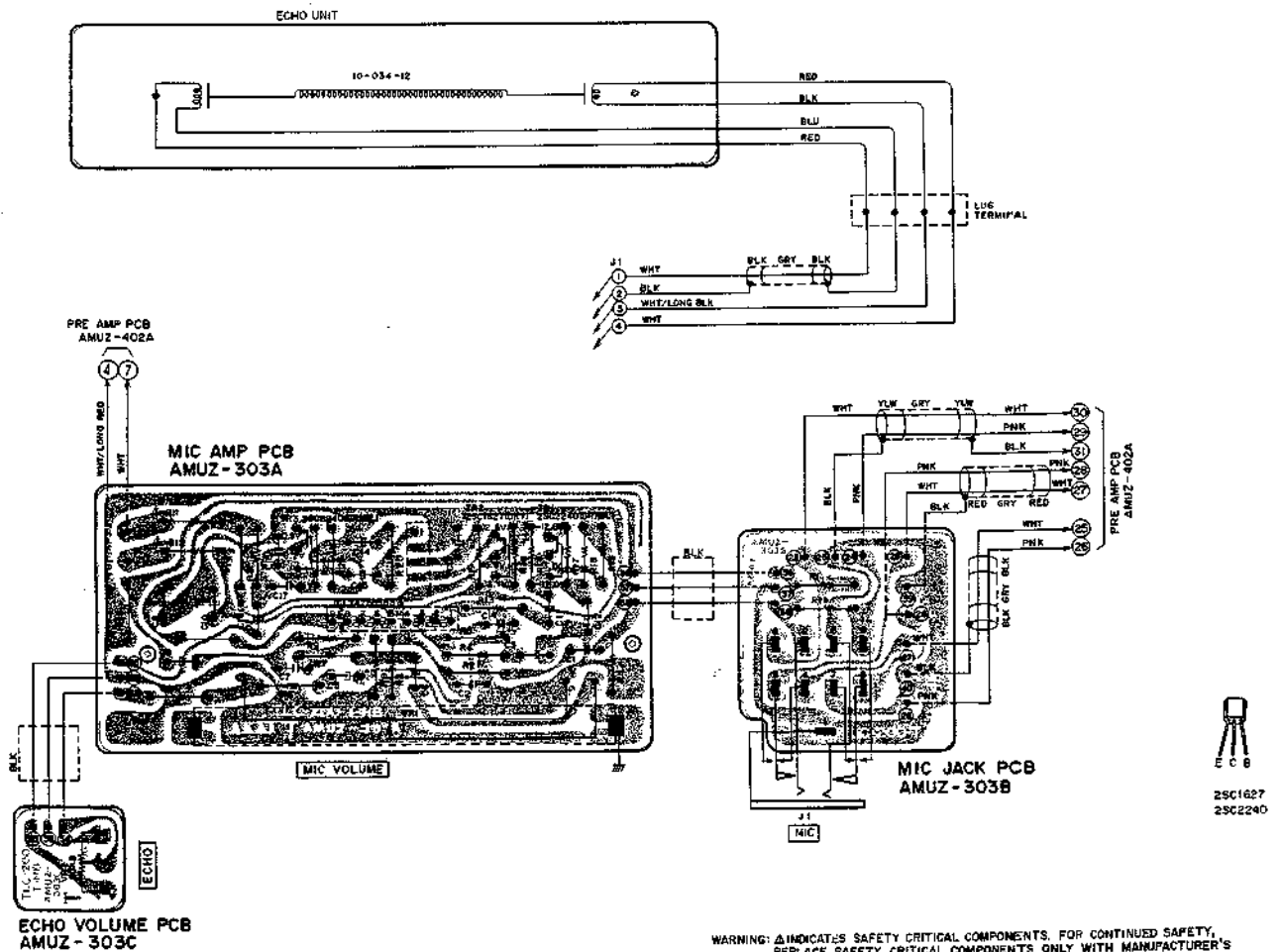

WARNING: Δ INDICATES SAFETY CRITICAL COMPONENTS. FOR CONTINUED SAFETY, REPLACE SAFETY CRITICAL COMPONENTS ONLY WITH MANUFACTURER'S RECOMMENDED PARTS
 AVERTISSEMENT: Δ IL INDIQUE LES COMPOSANTS CRITIQUES DE SÛRETÉ. POUR MAINTENIR LE DEGRÉ DE SÛRETÉ DE L'APPAREIL, NE REMPLACER LES COMPOSANTS DONT LE FONCTIONNEMENT EST CRITIQUE POUR LA SÛRETÉ QUE PAR DES PIÈCES RECOMMANDÉES PAR LE FABRICANT

5) Fuse P.C Board AMUZ-404 (JPN)

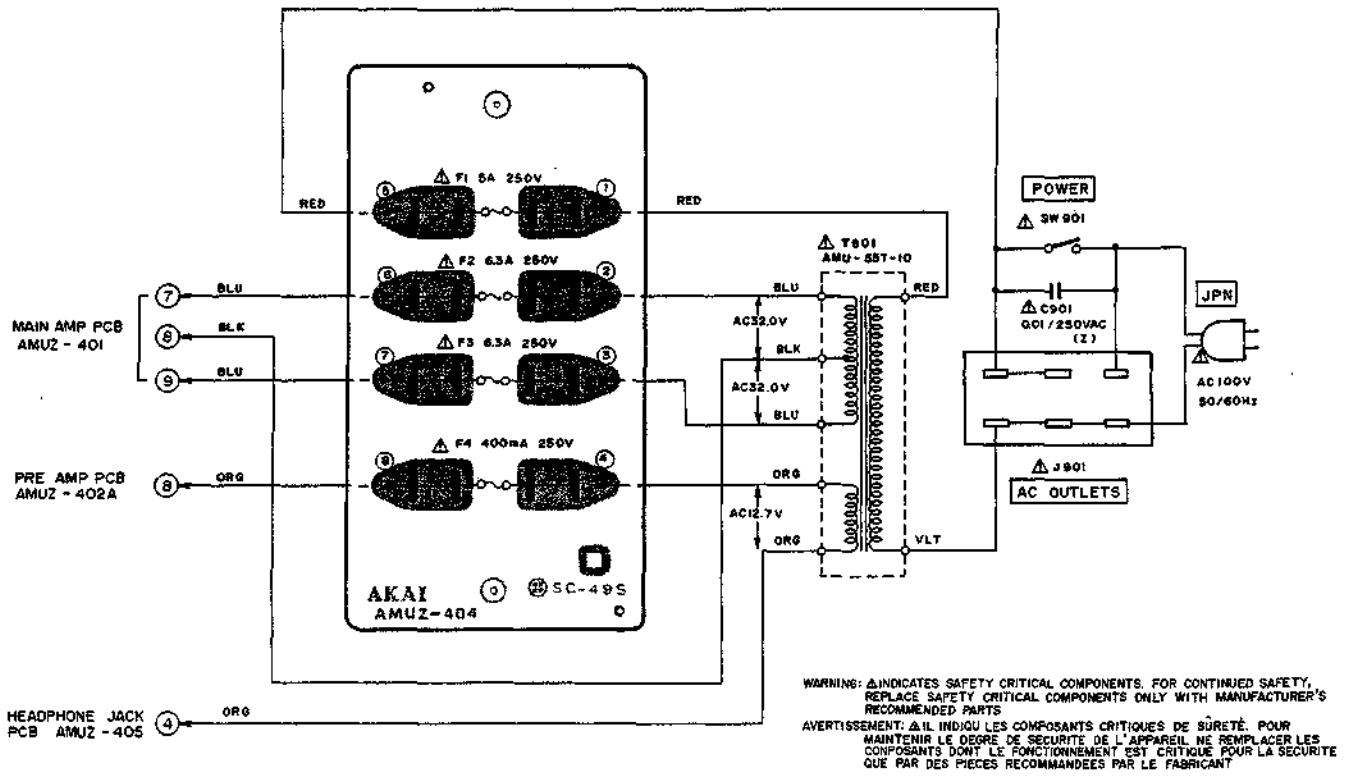

SECTION 3

PARTS LIST

TABLE OF CONTENTS

I. MODEL AT-S55/L	51
1. RECOMMENDED SPARE PARTS	51
2. TUNER P.C BOARD BLOCK	51
3. SYNTHESIZER P.C BOARD BLOCK	52
4. POWER SUPPLY P.C BOARD BLOCK	52
5. ASSEMBLY BLOCK	52
6. FINAL ASSEMBLY BLOCK	54
II. MODEL AM-U55/J	55
1. RECOMMENDED SPARE PARTS	55
2. MAIN AMP P.C BOARD BLOCK	55
3. GROUP (1) P.C BOARD BLOCK	56
4. GROUP (2) P.C BOARD BLOCK (JPN MODEL ONLY)	56
5. ASSEMBLY BLOCK	56
6. FINAL ASSEMBLY BLOCK	58
INDEX	59

Resistor and Capacitor which is not listed in this parts list, please refer to COMMON LIST FOR SERVICE PARTS.

HOW TO USE THIS PARTS LIST

1. This parts list is compiled by various individual blocks based on assembly process.
2. When ordering parts, please describe parts number, serial number, and model number in detail.
3. How to read list.

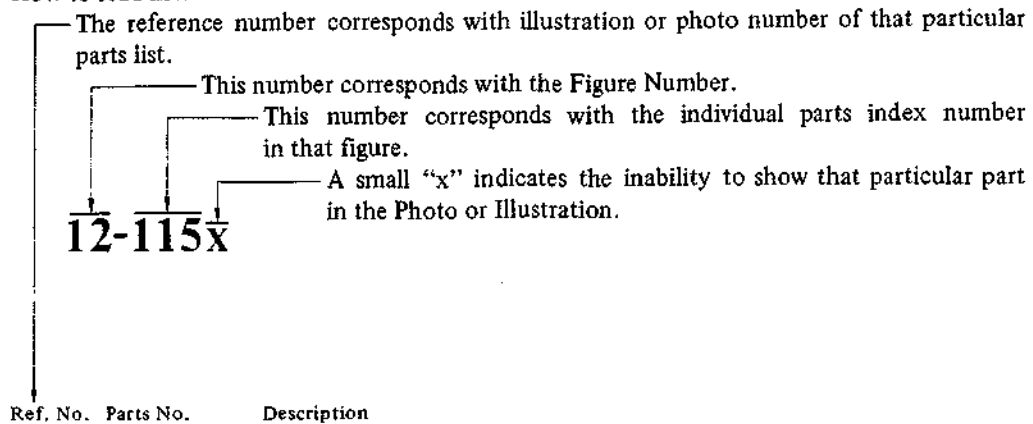

4. The symbol numbers shown on the P.C. Board list can be matched with the Composite Views of components of the Schematic Diagram of Service Manual.
5. The indications of Resistors and Capacitors in the photos of P.C. Board are being eliminated.
6. The shape of the parts and parts name, etc. can be confirmed by comparing them with the parts shown on the Electrical Parts Table of P.C. Board.
7. Both the kind of part and installation position can be determined by the Parts Number. To determine where a parts number is listed, utilize Parts Index at end of Parts List.
It is necessary first of all to find the Parts Number. This can be accomplished by using the Reference Number listed at right of parts number in the Parts Index. (meaning of ref. no. outlined in Item 3 above).
8. Utilize separate "Price List for Parts" to determine unit price. The most simple method of finding parts Price is to utilize the reference number.

CAUTION:

1. When placing an order for parts, be sure to list the parts no. model no., and description. There are instances in which if any of this information is omitted, parts cannot be shipped or the wrong parts will be delivered.
2. Please be careful not to make a mistake in the parts no. If the parts no. is in error, a part different from the one ordered may be delivered.
3. Because parts number and parts unit supply in the Preliminary Service Manual (Basic Parts List) may be partially changed, please use this parts list for all future reference.

WARNING: Δ INDICATES SAFETY CRITICAL COMPONENTS. FOR CONTINUED SAFETY, REPLACE SAFETY CRITICAL COMPONENTS ONLY WITH MANUFACTURER'S RECOMMENDED PARTS.

AVERTISSEMENT: Δ IL INDIQU LES COMPOSANTS CRITIQUES DE SURETE. POUR MAINTENIR LE DEGRE DE SECURITE DE L'APPAREIL NE REMPLACER LES COMPOSANTS DONT LE FONCTIONNEMENT EST CRITIQUE POUR LA SECURITE QUE PAR DES PIECES RECOMMANDEES PAR LE FABRICANT.

I. MODEL AT-S55/L

1. RECOMMENDED SPARE PARTS

Because, if the parts listed below are on hand, almost any repair can be accomplished, we suggest that you stock these Recommended Spare Parts Items.

REF. NO.	PARTS NO.	DESCRIPTION
1-1	BT300163	△ TRANS POWER AT-S55T-30 (C, A)
1-2	BT300165	△ TRANS POWER AT-S55T-40 (E)
1-3	BT300177	△ TRANS POWER AT-S55T-50 (B, S)
1-4	BT300185	△ TRANS POWER AT-S55T-70 (U)
1-5	ED223547	D SILICON DS131A 100/1.8A
1-6	ED200469	D SILICON H DS448 FA1 F10
1-7	ED322238	D SILICON 1B4B41 100/1.0A
1-8	ED224526	D SILICON 10D1 100/1.0A
1-9	ED325115	D ZENER H 05Z15 L
1-10	ED300257	D ZENER H 05Z6.8 L
1-11	ED306722	D ZENER H 05Z7.5 U
1-12	ED322247	D LED SLP-151D RED
1-13	ED322184	D LED SLP-152D RED
1-14	ED322772	D LED SLP-155D-01 RED
1-15	ED322215	D LED SLP-251D GRN
1-16	ED322773	D LED SLP-255D-01 GRN
1-17	ED200469	D SILICON H DS448 FA1 F10
1-18	ED224526	D SILICON 10D1 100/1.0A
1-19	ED324197	D VARACTOR KV1226X 2 THROW
1-20	ED323057	D VARISTER MV12
1-21	ED324194	D ZENER H 05Z5.1 L
1-22	EE202207	ANT BAR AT-S55 MW
1-23	EE307784	ANT BAR AT-S55L LW/MW
1-24	EE325119	FRONT END FD216U15 87-109MHz
1-25	EF300575	△ FUSE EAWK T 250V 0.10A (F1,2,3) (E,B,S)
1-26	EF300599	△ FUSE FST3100 T 250V 0.40A (F1,2,3) (E,B,S)
1-27	EF308933	△ FUSE TSC A 250V 0.20A (F2) (U)
1-28	EF309389	△ FUSE TSC A 250V 0.40A (F1) (U)
1-29	EF315334	△ FUSE TSC 125V 0.25A (F4) (C, A)
1-30	EF309390	△ FUSE TSC 125V 0.50A (F1,2,3)(C, A)
1-31	EI202210	IC AT400A
1-32	EI322248	IC LA1231N
1-33	EI202218	IC LA1245
1-34	EI322185	IC LA3380 (B)
1-35	EI307990	IC LB1260
1-36	EI307991	IC LB1269
1-37	EI315491	IC LB1405S
1-38	EI323247	IC TA7324P
1-39	EI306726	IC TC4069UBP
1-40	EI327064	IC TC9125P
1-41	EI315381	IC TD6102P
1-42	EI202211	IC TD62506P
1-43	EI327074	OSC X'TAL HC-18/U 9MHz
1-44	EM202209	IND LED SL1724-02W CHARACTER
1-45	ER328855	FILTER LC LP 12A1251 AKAI
1-46	ER322237	FILTER LC LP 209BLRG-3368N
1-47	ER315407	FILTER CE SFE10.7MMKA 10.7MHz
1-48	ES310839	△ SW PUSH SDG1P-E 01-1 E (U, E, B, S)
1-49	ES665875	△ SW PUSH SDG1P-J 01-1 UC (C, A)
1-50	ES300264	SW PUSH SUF12 2-02-02N
1-51	ES202219	SW PUSH SUF12 2-04-02N (L)
1-52	ES202212	SW PUSH SUF22 2 THROW
1-53	ES300194	SW PUSH SUF32 3 THROW (L)
1-54	ES323241	SW SLIDE SW0525-01-010 1-02-02
1-55	ES323240	SW SLIDE 12156 1-01-02N
1-56	ES328414	SW TACT KHC10901
1-57	ET316643	TR 2SC536K-NP F, G
1-58	ET323366	TR 2SD313HP D, E, F
1-59	ET307193	TR 2SD612K D, E, F
1-60	ET323232	TR FET 2SK19 Y
1-61	ET230534	TR FET 2SK30A Y
1-62	ET322244	TR 2SA608K-NP F, G
1-63	ET316643	TR 2SC536K-NP F, G
1-64	ET618873	TR 2SC930 E, F

2. TUNER P.C BOARD BLOCK

REF. NO.	PARTS NO.	DESCRIPTION
2-1	BAA3011A050A	PC TUNER BLK AT-S55 (U) (INCLUDING SW MUTE PCB) (U,E,B,S)
2-2	BAA3011A050B	PC TUNER BLK AT-S55(C) (INCLUDING SW MUTE PCB) (C,A)
2-3	BAA3011A050C	PC TUNER BLK AT-S55L (INCLUDING SW MUTE PCB)
TUNER PC BLOCK		
2-4	EE325119	FRONT END FD216U15 87-109MHz
2-IC1	EI322248	IC LA1231N
2-IC2	EI322185	IC LA3380 (B)
2-IC3	EI323247	IC TA7324P
2-IC4	EI202218	IC LA1245
2-IC5	EI315491	IC LB1405S
2-TR1to5	ET618873	TR 2SC930 E, F
2-TR6,7	ET316643	TR 2SC536K-NP F, G
2-TR8	ET230534	TR FET 2SK30A Y
2-TR9to14	ET316643	TR 2SC536K-NP F, G
2-TR18to21	ET316643	TR 2SC536K-NP F, G
2-D1to8	ED200469	D SILICON H DS448 FA1 F10
2-D10,11	ED200469	D SILICON H DS448 FA1 F10
2-D12,13	ED324197	D VARACTOR KV1226X DOUBLE
2-D14	ED323057	D VARISTER MV12
2-D15	ED200469	D SILICON H DS448 FA1 F10
2-SW1	ES323241	SW SLIDE SW0525-01-010 1-02-02
2-SW2	ES323240	SW SLIDE 12156 1-01-02N
2-SW3	ES202212	SW PUSH SUF22 2 THROW
2-SW3	ES300194	SW PUSH SUF32 3 THROW (L)
2-SW4	ES202219	SW PUSH SUF12 2-04-02N (L)
2-VR1	EV380215	R S-FIX H SR19R 3P 0.15W 104
2-VR2	EV427858	R S-FIX H SR19R 3P 0.15W 472
2-VR3	EV380215	R S-FIX H SR19R 3P 0.15W 104
2-VR4	EV618131	R S-FIX H CR19R 3P 0.50W 103
2-VR5to7	EV551452	R S-FIX H SR19R 3P 0.15W 223
2-L1	EO328137	COIL FIX 2 NI-0036 2.2 μH
2-T1	BT328136	COIL BALAN 75/300 OHMS
2-T2	EO328854	COIL DET2 Q228CEL-1098R
2-T3	EO322241	COIL VARI 1 CANS-3700Z 15mH
2-T4	EO307785	COIL VARI 2 CAN-4560N (L)
2-T5	EO307786	COIL OSC 2 7NR-6722Y 580 μH (L)
2-T6	EO202215	COIL OSC 2 7NR-6721Y 100 μH
2-T7	EO202216	COIL IFT 7MC-6733C 460KHz
2-T8	EO325117	COIL IFT CFMA-042 459KHz (U,E,B,S)
2-T8	EO315401	COIL IFT CFMA-014 460KHz (C,A)
2-FL1,2	ER315407	FILTER CE SFE10.7MMKA 10.7MHz
2-FL3	ER322237	FILTER LC LP 209BLRG-3368N
2-FL4,5	ER328855	FILTER LC LP 12A1251 AKAI
2-VC1	EC616342	C S-FIX H CTY122D33 1.5-16
2-VC2	EC675742	C S-FIX H CTY212D27 1.5-16 (L)
2-R4	ER324184	△ R CB H SNP FS RDS 1/4W 121J
2-R11	ER324184	△ R CB H SNP FS RDS 1/4W 121J
2-R17	ER324184	△ R CB H SNP FS RDS 1/4W 121J
2-R18	ER324185	△ R CB H SNP FS RDS 1/4W 221J
2-R35	ER324184	△ R CB H SNP FS RDS 1/4W 121J
2-R52	ER324185	△ R CB H SNP FS RDS 1/4W 221J
2-R134	ER324184	△ R CB H SNP FS RDS 1/4W 121J
2-FR1	ER318248	△ R FUSE ERD2FC 1/4W 47R0G
2-C20	EC300193	C EC V F05 NP SM 100M 16DC
2-C28	EC300193	C EC V F05 NP SM 100M 16DC
2-C33	EC300245	C EC V F05 NP SM 330M 10.0DC
2-C38,39	EC330309	C STY F05 CQ09S 511J 50DC (U,E,B,S)
2-C38,39	EC323252	C STY V CQ09S 771J 50DC (C,A)
2-C44	EC300254	C STY V F05 CQ09S 472J 50DC
2-C49	EC330310	C STY V F05 CQ09S 561J 50DC
2-C66	EC201253	C STY V F05 CQF09 161J 50DC
2-C67	EC300448	C STY V F05 CQ09S 4900G 50DC (L)
2-TM1	TA307988	TERMINAL SCREW TYPE T5559-B P 5P

SW MUTE PC BLOCK

2-SW1	ES300264	SW PUSH SUF12 2-02-02N
-------	----------	------------------------

3. SYNTHESIZER P.C BOARD BLOCK

REF. NO.	PARTS NO.	DESCRIPTION
3-1	BAA3011A060A	SYNTHESIZER PC BLK AT-S55 (U) (U,E,B,S)
3-2	BAA3011A060B	SYNTHESIZER PC BLK AT-S55 (C) (C,A)
3-3	BAA3011A060C	SYNTHESIZER PC BLK AT-S55L
3-IC1	EI315381	IC TD6102P
3-IC2	EI327064	IC TC9125P
3-IC3	EI202210	IC AT400A
3-IC4	EI306726	IC TC4069UBP
3-IC5	EI307990	IC LB1260
3-IC6	EI307991	IC LB1269
3-IC7	EI202211	IC TD62506P
3-TR1	ET323232	TR FET 2SK19 Y
3-TR2	ET316643	TR 2SC536K-NP F,G
3-TR3	ET230534	TR FET 2SK30A Y
3-TR4,5	ET316643	TR 2SC536K-NP F,G
3-TR6	ET230534	TR FET 2SK30A Y
3-TR7,8	ET316643	TR 2SC536K-NP F,G
3-TR9,10	ET322244	TR 2SA608K-NP F,G
3-TR11	ET322244	TR 2SA608K-NP F,G (U,E,B,S)
3-TR12	ET322244	TR 2SA608K-NP F,G (L)
3-TR13,14	ET322244	TR 2SA608K-NP F,G
3-TR15	ET316643	TR 2SC536K-NP F,G
3-TR16to19	ET322244	TR 2SA608K-NP F,G
3-TR20,21	ET316643	TR 2SC536K-NP F,G
3-D1 to 5	ED200469	D SILICON H DS448 FA1 F10
3-D6	ED224526	D SILICON 10D1 100/1.0A
3-D7	ED200469	D SILICON H DS448 FA1 F10
3-D8,9	ED200469	D SILICON H DS448 FA1 F10 (U,E,B,S)
3-D10	ED200469	D SILICON H DS448 FA1 F10
3-D11	ED200469	D SILICON H DS448 FA1 F10 (C,A)
3-D12	ED200469	D SILICON H DS448 FA1 F10 (U,E,B,S)
3-D13	ED200469	D SILICON H DS448 FA1 F10 (L)
3-D14to16	ED200469	D SILICON H DS448 FA1 F10
3-D17	ED200469	D SILICON H DS448 FA1 F10 (L)
3-D18to20	ED200469	D SILICON H DS448 FA1 F10
3-D21	ED324194	D ZENER H 05Z5.1 L
3-D22to29	ED200469	D SILICON H DS448 FA1 F10
3-J3	EJ315377	SOCKET IC S-12457 P 42P
3-VR1	EV241323	R S-FIX H SR19R 3P 0.15W 10S
3-L1	EO328137	COIL FIX 2 NI-0036 2.2μH
3-L2	EO485278	COIL FIX1 FL05H 220μH K
3-T1	BT327067	COIL IFT RMC-44357Z 460KHz
3-IND1	EM202209	IND LED SL1724-02W CHARACTER
3-X1	EI327074	OSC X'TAL HC-18/U 9MHz
3-VC1	EC300191	C S-FIX H ECV-1 ZW30x32E 4.0-34

4. POWER SUPPLY P.C BOARD BLOCK

REF. NO.	PARTS NO.	DESCRIPTION
4-1	BAA3011A070A	POWER PC BLK AT-S55 (U) (U)
4-2	BAA3011A070B	POWER PC BLK AT-S55 (C) (C,A)
4-3	BAA3011A070C	POWER PC BLK AT-S55 (E) (E,B,S)
4-TR1	ET316643	△ TR 2SC536K-NP F,G
4-TR2	ET307193	△ TR 2SD612K D,E,F
4-TR3	ET316643	△ TR 2SC536K-NP F,G
4-TR4	ET307193	△ TR 2SD612K D,E,F
4-TR5	ET316643	△ TR 2SC536K-NP F,G
4-TR6	ET323366	△ TR 2SD313HP D,E,F
4-TR7	ET307193	△ TR 2SD612K D,E,F
4-TR8	ET316643	△ TR 2SC536K-NP F,G
4-D1	ED322238	△ D SILICON 1B4B41 100/1.0A
4-D2	ED306722	△ D ZENER H 05Z7.5 U
4-D3	ED300257	△ D ZENER H 05Z6.8 L
4-D4	ED200469	△ D SILICON H DS448 FA1 F10
4-D5	ED223547	△ D SILICON DS131A 100/1.8A
4-D6	ED325115	△ D ZENER H 05Z15 L
4-D7	ED224526	△ D SILICON 10D1 100/1.0A
4-D8	ED325115	△ D ZENER H 05Z15 L
4-SW1	ES310839	△ SW PUSH SDG1P-E 01-1 E (U,E,B,S)
4-SW1	ES665875	△ SW PUSH SDG1P-J 01-1 UC (C,A)
4-R9	ER324186	△ R CBH SNP FS RDS 1/4W 681J
4-R14	ER669328	△ R SD 1/2W 225J (C,A)
4-C15,16	EC320548	C CE V F 103Z 250AC
4-C22	EC320548	C CE V F 103Z 250AC
4-C29	EC320548	△ C CE V F 103Z 250AC (U)
4-C29	EC314688	△ C CE V FZ 103P 125AC (C,A)
4-C29	EC327382	△ C MP V 472M 250AC (E,B,S)

ASSEMBLY BLOCK

REF. NO.	PARTS NO.	DESCRIPTION
LED PC BLOCK		
5-1x	ED322247	D LED SLP-151D RED (D1)
5-2x	ED322215	D LED SLP-251D GRN (D2)
5-3x	ED322184	D LED SLP-152D RED (D3)
BATTERY PC BLOCK		
5-4x	EA202205	PC BATTERY
ASSEMBLY BLOCK		
5-5	SP300873A	PANEL REAR AT-S55 (U)
5-6x	SP300873B	PANEL REAR AT-S55 (C)
5-7x	SP300873C	PANEL REAR AT-S55 (A)
5-8x	SP300873D	PANEL REAR AT-S55 (E)
5-9x	SP300873E	PANEL REAR AT-S55 (S)
5-10x	SP300873F	PANEL REAR AT-S55L (E)
5-11x	SP300873G	PANEL REAR AT-S55L (B,S)
5-12	ZS319460	T2BR30x06STL BZN PROJECTION

When ordering parts, please quote Parts Number, Description and Model Number.

5. ASSEMBLY BLOCK

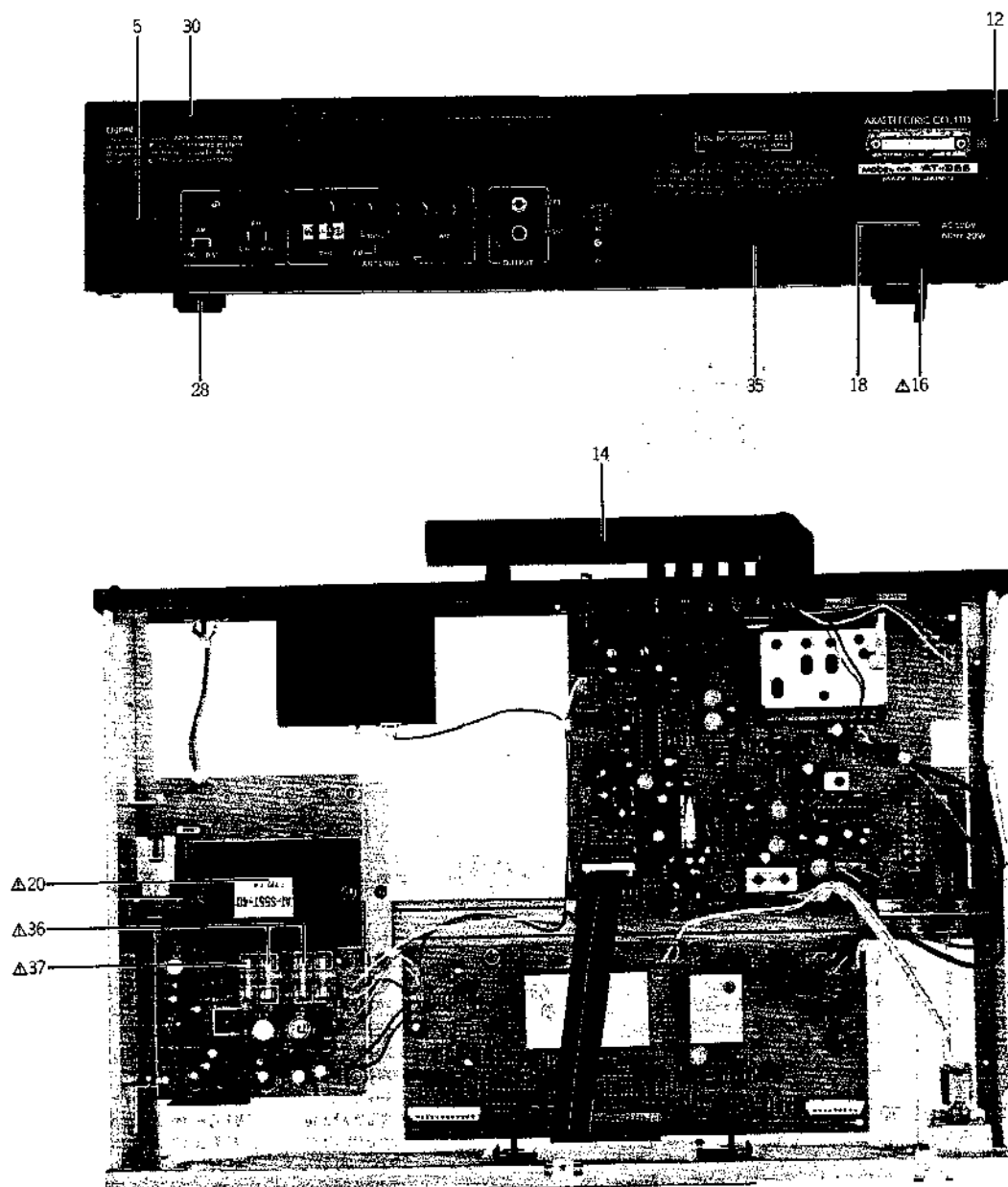

REF. NO.	PARTS NO.	DESCRIPTION	REF. NO.	PARTS NO.	DESCRIPTION
5-13x	ZS308673	T2PAN30x20STL NI3 GUIDE	5-29x	ZS463094	T2BID40x08STL CMT
5-14	EE202207	ANT BAR AT-S55 MW	5-30	ZS319460	T2BR30x06STL BZN PROJECTION
5-15x	EE307784	ANT BAR AT-S55L LW/MW	5-31x	ZW305013	RV POP32 (A)
5-16	EW306428	Δ AC CORD 2 CORES KP-205A, VFF UCJ (U)	5-32x	EW315767	Δ AC CORD 2 CORES KP-419C/ KS-15 E (E)
5-17x	EW305691	Δ AC CORD 2 CORES KP-8,SPT-1 UC (C,A)	5-33x	EW322401	Δ AC CORD 2 CORES KP-560/ S-15 S (S)
5-18	SZ631945	STRAIN RELIEF SR-4N-4	5-34x	EW302995	Δ AC CORD 2 CORES VM-0112 B (B)
5-19x	EJ301513	Δ SOCKET INLET S-I6453 E 2P (E,B,S)	5-35	TA202208	BATTERY CASE ASSY AT-S55
5-20	BT300185	Δ TRANS POWER AT-S55T-70 (U)	5-36	EF309389	Δ FUSE TSC A 250V 0.40A (F1)(U)
5-21x	BT300163	Δ TRANS POWER AT-S55T-30 (C,A)	5-37	EF308933	Δ FUSE TSC A 250V 0.20A (F2)(U)
5-22x	BT300165	Δ TRANS POWER AT-S55T-40 (E)	5-38x	EF309390	Δ FUSE TSC 125V 0.50A (F1,2,3) (C,A)
5-23x	BT300177	Δ TRANS POWER AT-S55T-50 (B,S)	5-39x	EF315334	Δ FUSE TSC 125V 0.25A (F4)(C,A)
5-24x	ZS328675	BT BR30x16STL CMT PW080	5-40x	EF300599	Δ FUSE FST3100 T 250V 0.40A (F1,2,3)(E,B,S)
5-25x	ZW698308	RV NYL30x055 BL	5-41x	EF300575	Δ FUSE EAWK T 250V 0.10A (F1,2,3)(E,B,S)
5-26x	SP200694	BOTTOM PLATE			
5-27x	ZS447840	T2BR30x08STL CMT			
5-28	SA311742	ROUND FOOT			

When ordering parts, please quote Parts Number, Description and Model Number.

6. FINAL ASSEMBLY BLOCK

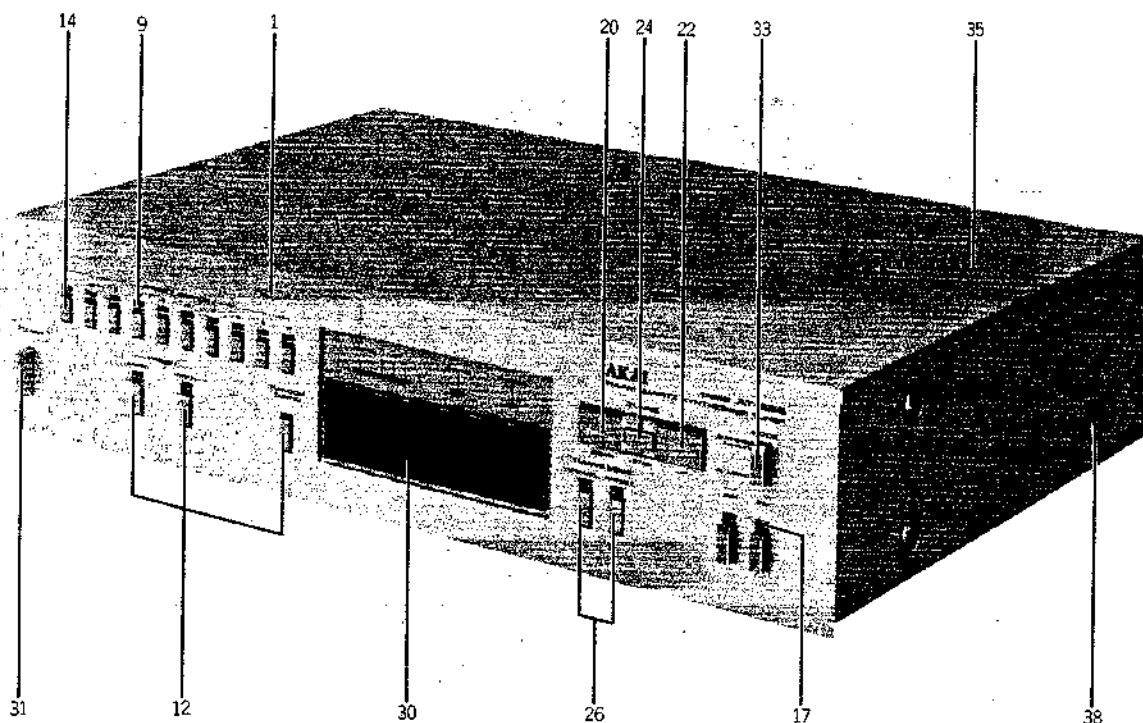

FINAL ASSEMBLY BLOCK

REF. NO.	PARTS NO.	DESCRIPTION	REF. NO.	PARTS NO.	DESCRIPTION
FRONT PANEL BLOCK			FINAL ASSEMBLY BLOCK		
6-1	SP300872A	PANEL FRONT AT-S55	6-28x	TA200911A	INDICATOR
6-2x	SP300872B	PANEL FRONT AT-S55-BL	6-29x	TA200911B	INDICATOR (BL)
6-3x	SP300872C	PANEL FRONT AT-S55L	6-30	SZ321494	METER WINDOW
6-4x	SP300872D	PANEL FRONT AT-S55L-BL	6-31	SB316498	BUTTON (B)
6-5x	SE200903A	ESCUTCHEON (A)	6-32x	SB316499	BUTTON (B-BL)
6-6x	SE200903B	ESCUTCHEON (A-BL)	6-33	SB200915A	BUTTON
SW PC (A) BLOCK			6-34x	SB200915B	BUTTON(BL)
6-7x	ES328414	SW TACT KHC10901 (SW1to13)	6-35	SP200921A	UPPER PLATE (A)
6-8x	ED200469	D SILICON H DS448 FA1 F10 (D1to12)	6-36x	SP200921B	UPPER PLATE (A-BL)
6-9	ED322772	D LED SLP-155D-01 RED (D13to24)	6-37x	SP200921C	UPPER PLATE (B)
6-10x	SE301196A	ESCUTCHEON PRESET	6-38	ZS322570	ST BID40x08STL NI3
6-11x	SE301196B	ESCUTCHEON PRESET-BL	6-39x	ZS322580	ST BID40x08STL BNI
6-12	SK301221A	KNOB PUSH (A)	6-40x	ZW305013	RV POP32 (A)
6-13x	SK301221B	KNOB PUSH (A)-BL			
6-14	SK301269A	KNOB PUSH (B)			
6-15x	SK301269B	KNOB PUSH (B)-BL			
SW PC (B) BLOCK					
6-16x	ES328414	SW TACT KHC10901 (SW1to5)			
6-17	ED322773	D LED SLP-255D-01 GEN (D1to4)			
6-18x	ES301335A	ESCUTCHEON TUNING			
6-19x	SE301335B	ESCUTCHEON TUNING-BL			
6-20	SK301369A	KNOB TUNING (A)			
6-21x	SK301369B	KNOB TUNING (A)-BL			
6-22	SK301406A	KNOB TUNING (B)			
6-23x	SK301406B	KNOB TUNING (B)-BL			
6-24	SK301407A	KNOB TUNING (C)			
6-25x	SK301407B	KNOB TUNING (C)-BL			
6-26	SK301221A	KNOB PUSH (A)			
6-27x	SK301221B	KNOB PUSH (A)-BL			

II. MODEL AM-U55/J

1. RECOMMENDED SPARE PARTS

Because, if the parts listed below are on hand, almost any repair can be accomplished, we suggest that you stock these Recommended Spare Parts Items.

REF. NO.	PARTS NO.	DESCRIPTION
1-1	BT200792	△ TRANS POWER AM-U55T-10 (J)
1-2	BT202177	△ TRANS POWER AM-U55T-20 (A)
1-3	BT202178	△ TRANS POWER AM-U55T-30 (C)
1-4	BT202179	△ TRANS POWER AM-U55T-40 (E)
1-5	BT202180	△ TRANS POWER AM-U55T-50 (B,S)
1-6	BT202181	△ TRANS POWER AM-U55T-70 (U)
1-7	BZA2008A080A	REVERSE UNIT BLK AM-U55J (J)
1-8	ED322247	D LED SLP-151D RED
1-9	ED322773	D LED SLP-255D-01 GRN
1-10	ED200749	D SILICON DBA60-K15 400/6.0A
1-11	ED300924	D SILICON GP08D 200/0.8A
1-12	ED200469	D SILICON H DS448 FA1 F10
1-13	ED214457	D SILICON H 1S2472
1-14	ED201445	D ZENER H WZ-187
1-15	ED557111	D ZENER H WZ-210
1-16	ED201448	D ZENER H WZ-280
1-17	EF325683	△ FUSE GGS A 125V 5A (C,A)
1-18	EF668474	△ FUSE SEMKO T 250V 0.40A (E,B,S)
1-19	EF623125	△ FUSE SEMKO T 250V 2.5A (E,B,S)
1-20	EF242605	△ FUSE SEMKO T 250V 6.30A (E,B,S)
1-21	EF303348	△ FUSE ST6 125V 6.30A (C,A)
1-22	EF200952	△ FUSE TSC A TYPE 250V 6.30A (J)
1-23	EF309389	△ FUSE TSC A 250V 0.40A (J)
1-24	EF306951	△ FUSE TSC A 250V 2.5A (U)
1-25	EF326613	△ FUSE TSC A 250V 5A (J)
1-26	EF326613	△ FUSE TSC A 250V 5A (U)
1-27	EF308848	△ FUSE TSC 125V 0.40A (C,A)
1-28	EI329612	IC LB1409
1-29	EI200795	IC M5213L
1-30	EI201446	IC M5214L
1-31	EI323563	IC STK-3042
1-32	EI200794	IC STK2155
1-33	EI323564	IC TA7317P
1-34	EI200938	IC TA75558S
1-35	EJ296853	△ SOCKET INLET CM-3 UCEB 3P (E,B,S)
1-36	EJ240535	△ SOCKET OUTLET S-16462 UC 3x2P
1-37	EJ316531	PHONE J 3P HLJ0315-010 6.3 2T
1-38	EJ329265	PHONE J 3P HLJ0315-040 6.3 2C
1-39	EJ322582	TERMINAL PUSH S-Q2370 S 4P
1-40	EP323565	RELAY POWER G2Z-222P-US 2NO 24V
1-41	ES310839	△ SW PUSH SDG1P-E 01-1 E (E,B,S)
1-42	ES679566	△ SW PUSH SDG1P001 02 UC (C,A)
1-43	ES315158	△ SW PUSH SDV1P 01-1 J (J)
1-44	ES200798	SW PUSH SUF24 2 THROW
1-45	ES202185	SW PUSH SUF24 2 THROW
1-46	ES200797	SW PUSH SUF84E01A 8 THROW
1-47	ET322778	TR 2SA608K-NP E,F,G
1-48	ET322598	TR 2SB632K E,F
1-49	ET293253	TR 2SC1627 O, Y
1-50	ET307195	TR 2SC2240 GR,BL
1-51	ET310148	TR 2SD612K E,F
1-52	EV315414	R S-FIX H D8 3P 203
1-53	EV315413	R S-FIX H D8 3P 503
1-54	EV200936	VR ROTARY 16P10x1B B503
1-55	EV325629	VR ROTARY 16P20x1Q C104
1-56	EV325630	VR ROTARY 16P20x1R C104
1-57	EV329572	VR ROTARY 16P22x0A 12254 3BM254
1-58	EV200937	VR SLIDE 45P1SV0B B503

2. MAIN AMP P.C BOARD BLOCK

REF. NO.	PARTS NO.	DESCRIPTION
2-1	BAA2008C070A	MAIN AMP PC BLK AM-U55 (EXCEPT J)
2-2	BAA2008A020A	MAIN AMP PC BLK AM-U55J
2-IC1	EI323563	△ IC STK-3042
2-IC2	EI200794	△ IC STK2155
2-IC3	EI323564	IC TA7317P
2-TR1	ET307195	TR 2SC2240 GR,BL
2-TR2	ET322778	TR 2SA608K-NP E,F,G
2-TR3	ET310148	△ TR 2SD612K E,F
2-TR4	ET322598	△ TR 2SB632K E,F
2-D1,2	ED200469	D SILICON H DS448 FA1 F10
2-D3,4	ED214457	D SILICON H 1S2472
2-D5	ED200749	△ D SILICON DBA60-K15 400/6.0A
2-D6	ED557111	△ D ZENER H WZ-210
2-D7	ED201445	△ D ZENER H WZ-187
2-D8,9	ED200469	△ D SILICON H DS448 FA1 F10
2-D10,11	ED201448	△ D ZENER H WZ-280
2-VR1	EV315413	R S-FIX H D8 3P 503
2-L1	EO324220	COIL FIX 2 2.2μH
2-RL1	EP323565	RELAY POWER G2Z-222P-μS 2NO 24V
2-R8,9	ER308875	△ R CB H SNP FS RDS 1/2W 100J
2-R10,11	ER328082	△ R CB H SNP FS RDS 1/4W 332J
2-R29	ER300159	△ R OMF H FS 2W 911J
2-R33,34	ER302240	R CB H SNP FS RDS 1/2W 222J
2-R35,36	ER322787	R CB H SNP FS RDS 1/4W 100J
2-FR1,2	ER200747	△ R FUSE ERD2FC 1/4W 68R0G
2-FR3,4	ER200746	△ R FUSE ERD2FC 1/4W 100G
2-C14,15	EC200949	C EC V F05 NP SM 470M 10DC
2-C18,19	EC326583	C MMY V CUT CF921 473K 400DC
2-C20to23	EC320548	C CE V F 103Z 250AC
2-C24,25	EC200811	C EC V SNP NM 103 50DC
2-C32	EC320548	C CE V F 103Z 250AC

3. GROUP (1) P.C BOARD BLOCK

REF. NO.	PARTS NO.	DESCRIPTION
3-1	BAA2008C130A	GROUP PC(1)BLK AM-U55(U) (INCLUDING PRE AMP PCB,VOL PCB) (U,E,B,S)
3-2	BAA2008C130B	GROUP PC(1)BLK AM-U55(C) (INCLUDING PRE AMP PCB,VOL PCB) (C,A)
3-3	BAA2008A050A	GROUP PC(1)BLK AM-U55J (INCLUDING PRE AMP PCB, VOL PCB)
PRE AMP PC BLOCK		
3-IC1	EI201446	IC M5214L
3-IC2	EI200938	IC TA75558S (J)
3-IC3	EI200795	IC M5213L
3-IC4	EI329612	IC LB1409
3-D1	ED300924	△ D SILICON GP08D 200/0.8A
3-D2	ED200469	△ D SILICON H DS448 FA1 F10
3-D3	ED200469	D SILICON H DS448 FA1 F10
3-SW1to8	ES200797	SW PUSH SUF84E01A 8 THROW
3-SW9,10	ES200798	SW PUSH SUF24 2 THROW
3-VR1	EV325629	VR ROTARY 16P20x1Q C104
3-VR2	EV325630	VR ROTARY 16P20x1R C104
3-VR3	EV315414	R S-FIX H D8 3P 203
3-R9,10	ER324480	△ R CB H SNP FS RDS 1/4W 470J
3-R22	ER323074	△ R CB H SNP FS RDS 1/4W 102J (J)
3-R23	ER316802	△ R CB H SNP FS RDS 1/4W 471J (J)
3-R44,45	ER324480	△ R CB H SNP FS RDS 1/4W 470J
3-R65	ER328067	△ R CB H SNP FS RDS 1/4W 331J
3-C37	EC320548	C CE V F 103Z 250AC
VOL PC BLOCK		
3-VR1	EV329572	VR ROTARY 16P22x0A 1Z254 3BM254

4. GROUP (2) P.C BOARD BLOCK (JPN MODEL ONLY)

REF. NO.	PARTS NO.	DESCRIPTION
4-1	BAA2007A100B	GROUP PC (2) BLK AM-U55J (INCLUDING MIC AMP PCB, MIC JACK PCB, ECHO VOL PCB)
MIC AMP PC BLOCK		
4-IC1	EI200938	IC TA75558S
4-TR1	ET307195	TR 2SC2240 GR,BL
4-TR2	ET293253	TR 2SC1627 O,Y
4-TR3	ET307195	TR 2SC2240 GR,BL
4-VR1	EV200937	VR SLIDE 45P1SV0B B503
4-R11	ER200939	△ R CB H SNP FS RDS 1/4W 181J
4-R12	ER322591	△ R CB H SNP FS RDS 1/4W 101J
MIC JACK PC BLOCK		
4-J1	EJ330544	PHONE J 3P HLJ0315-010 6.3 2T
ECHO VOL PC BLOCK		
4-VR1	EV200936	VR ROTARY 16P10x1B B503

ASSEMBLY BLOCK

REF. NO.	PARTS NO.	DESCRIPTION
REVERB UNIT BLOCK		
5-1x	BZA2008A080A	REVERB UNIT BLK AM-U55J
LED (A) BLOCK		
5-2x	ED322247	D LED SLP-151D RED (D1to9)
LED (B) BLOCK		
5-3x	ED322773	D LED SLP-255D-01 GRN (D1to5)
LED (C) BLOCK		
5-4x	ED322773	D LED SLP-255D-01 GRN (D1,2)
SW PC BLOCK		
5-5	ES202185	SW PUSH SUF24 2 THROW(SW1,2)
POWER SW BLOCK		
5-6	ES310839	△ SW PUSH SDG1P-E 01-1 E (U)
5-7x	ES315158	△ SW PUSH SDV1P 01-1 J (J)
5-8x	ES679566	△ SW PUSH SDG1P001 02 UC(C,A)
5-9x	ES310839	△ SW PUSH SDG1P-E 01-1 E (E,B,S)
5-10x	EC320548	△ C CE V F 103Z 250AC (U,J)
5-11x	EC314688	△ C CE V FZ 103P 125AC (C,A)
5-12x	EC330307	△ C MMY V ECQUF 472M 250A (E,B,S)
PIN JACK PC BLOCK		
5-13	EJ323144	PIN J T5718-C P6P (J1to3)
HEADPHONE PC BLOCK		
5-14x	EJ316156	PHONE J 3P HLJ0315-020 6.3 (EXCEPT J) (J1)
5-15x	EJ329265	PHONE J 3P HLJ0315-040 6.3 2C (J) (J1)
5-16x	ER658034	△ R OMF H FS 2W 221J (R1,2)
ASSEMBLY BLOCK		
5-17	SP200701F	REAR PANEL AM-U55 (U)
5-18x	SP200701A	REAR PANEL AM-U55J
5-19x	SP200701G	REAR PANEL AM-U55 (C,A)
5-20x	SP200701H	REAR PANEL AM-U55 (E)
5-21x	SP200701J	REAR PANEL AM-U55 (B,S)
5-22	EJ240535	△ SOCKET OUTLET S-16462 UC 3x2P
5-23	EJ322582	TERMINAL PUSH S-Q2370 S 4P
5-24	EW306428	△ AC CORD 2 CORES KP-205A, VFF UCJ (U)
5-25x	EW306427	△ AC CORD 2 CORES KP-211, VFF J (J)
5-26x	EW305691	△ AC CORD 2 CORES KP-8, SPT-1 UC (C,A)
5-27	SZ631945	STRAIN RELIEF SR-4N-4
5-28x	EJ296853	SOCKET INLET CM-3 UCEB 3P (E,B,S)
5-29	ZS463353	T2BR30x08STL BNI
5-30	EJ329610	TERMINAL W/SCREW UB-0067L1P
5-31	ZS319460	T2BR30x06STL BZN PROJECTION RV POP32 (A)
5-32x	ZW305013	T2BR30x06STL BZN PROJECTION
5-33	ZS319460	△ TRANS POWER AM-U55T-70(U)
5-34	BT202181	△ TRANS POWER AM-U55T-10(J)
5-35x	BT200792	△ TRANS POWER AM-U55T-30(C)
5-36x	BT202178	△ TRANS POWER AM-U55T-20(A)
5-37x	BT202177	△ TRANS POWER AM-U55T-40(E)
5-38x	BT202179	△ TRANS POWER AM-U55T-50 (B,S)
5-39x	BT202180	△ TRANS POWER AM-U55T-50 (B,S)
5-40x	ZW413267	N FRANGE 40STL CMT
5-41x	ZS424056	PAN40x10STL CMT
5-42x	EZ328570	CAP 3PINLET (B)
5-43x	SP202142	BOTTOM PLATE (B) (EXCEPT J)
5-44x	SP200714	BOTTOM PLATE (J)
5-45x	ZS325495	T2BR30x06STL CMT
5-46x	ZS447840	T2BR30x08STL CMT
5-47	SA311742	ROUND FOOT
5-48x	ZS565942	T2PAN40x08STL CMT

5. ASSEMBLY BLOCK

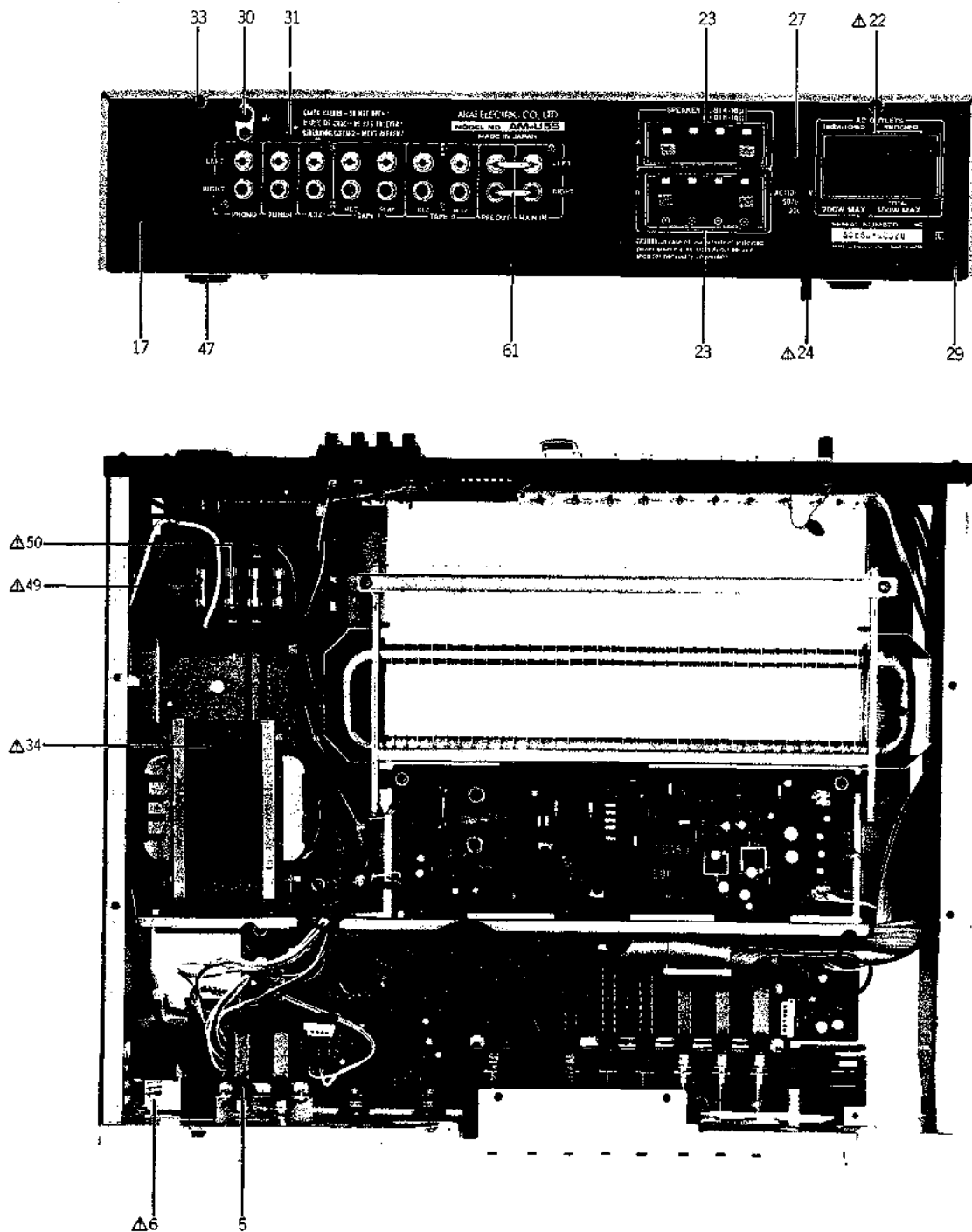

REF. NO.	PARTS NO.	DESCRIPTION	REF. NO.	PARTS NO.	DESCRIPTION
5-49	EF326613	△ FUSE TSC A 250V 5A (F1)(U)	5-56x	EF303348	△ FUSE ST6 125V 6.30A (F2,3) (C,A)
5-50	EF306951	△ FUSE TSC A 250V 2.5A(F1)(U)	5-57x	EF308848	△ FUSE TSC 125V 0.40A(F4)(C,A)
5-51x	EF326613	△ FUSE TSC A 250V 5A (F1)(J)	5-58x	EF623125	△ FUSE SEMKO T 250V 2.5A (F1) (E,B,S)
5-52x	EF200952	△ FUSE TSC A TYPE 250V 6.30A (F2) (J)	5-59x	EF242605	△ FUSE SEMKO T 250V 6.30A (F2,3)(E,B,S)
5-53x	EF200952	△ FUSE TSC A TYPE 250V 6.30A (F3) (J)	5-60x	EF668474	△ FUSE SEMKO T 250V 0.40A (F4) (E,B,S)
5-54x	EF309389	△ FUSE TSC A 250V 0.40A(F4)(J)	5-61	EJ326185	PLUG SHORT PIN UZ-0036
5-55x	EF325683	△ FUSE GGS A 125V 5A(F1)(C,A)			

When ordering parts, please quote Parts Number, Description and Model Number.

6. FINAL ASSEMBLY BLOCK

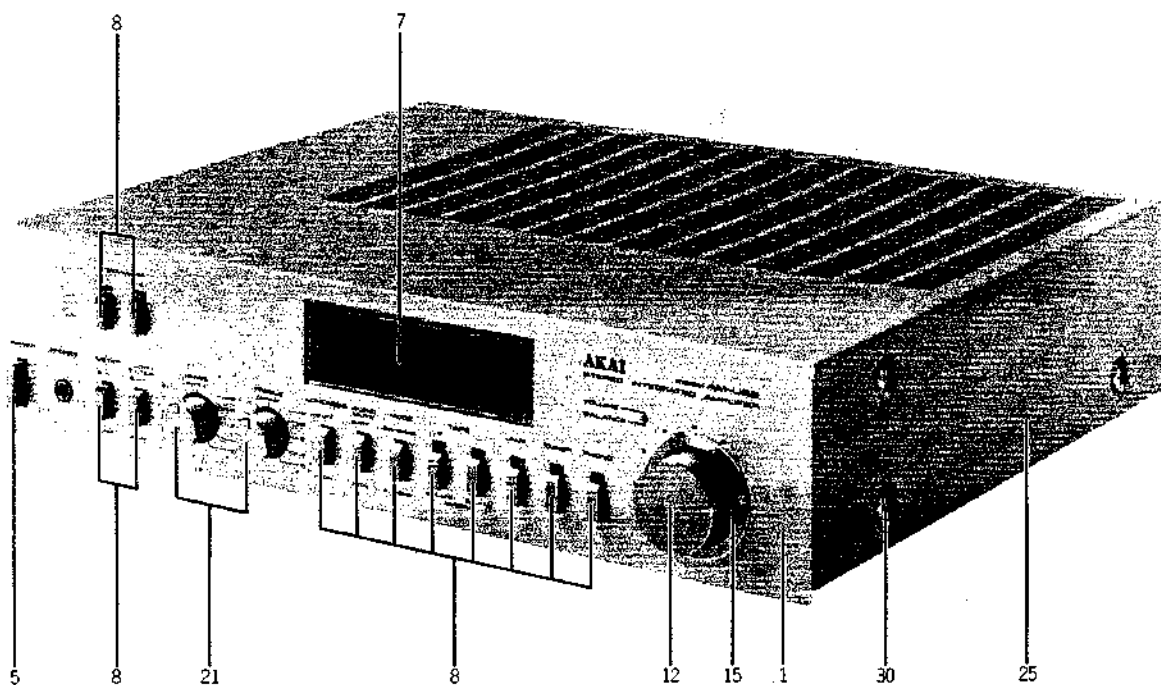

FINAL ASSEMBLY BLOCK

REF. NO.	PARTS NO.	DESCRIPTION
FRONT PANEL BLOCK		
6-1	BDA2008C120A	FRONT PANEL BLK AM-U55
6-2x	BDA2008C120B	FRONT PANEL BLK AM-U55-BL
6-3x	BDA2008A120A	FRONT PANEL BLK AM-U55J
6-4x	BDA2008A120B	FRONT PANEL BLK AM-U55J-BL
6-5	SB322576	BUTTON (A)
6-6x	SB322577	BUTTON (A-BL)
6-7	SZ321494	METER WINDOW
FINAL ASSEMBLY BLOCK		
6-8	SB200915A	BUTTON
6-9x	SB200915B	BUTTON (BL)
6-10x	SZ200770A	MASK
6-11x	SZ200770B	MASK (BL)
6-12	SK200651	DOUBLE KNOB (UPPER-2)
6-13x	SK200652	DOUBLE KNOB (UPPER-2-BL)
6-14x	ZW260144	PW61x100x030NYL
6-15	SK200772A	DOUBLE KNOB (LOWER)
6-16x	SK200772B	DOUBLE KNOB (LOWER-BL)
6-17x	SK200647	KNOB (A-2) (J)
6-18x	SK200648	KNOB (A-2-BL) (J)
6-19x	SK200778A	KNOB (J)
6-20x	SK200778B	KNOB (BL) (J)
6-21	SK200645	KNOB (A-2)
6-22x	SK200646	KNOB (A-2-BL)
6-23x	SZ316376	KNOB CUSHION (A)
6-24x	SZ316377	KNOB CUSHION (B)
6-25	SP202143A	UPPER PLATE (C)(U,C,E,B,S)
6-26x	SP202143B	UPPER PLATE (C-BL)(U,C,E,B,S)
6-27x	SP200717A	UPPER PLATE (A) (J)
6-28x	SP200717B	UPPER PLATE (A-BL) (J)
6-29x	SP202143C	UPPER PLATE (D) (A)
6-30	ZS322570	ST BID40x08STL N13
6-31x	ZS322580	ST BID40x08STL BNI
6-32x	ZS319460	T2BR30x06STL BZN PROJECTION
6-33	ZS322580	ST BID40x08STL BNI
6-34	ZS319460	T2BR30x06STL BZN PROJECTION

When ordering parts, please quote Parts Number, Description and Model Number.

INDEX

I. MODEL AT-S55/L

PARTS No.	REF. No.	PARTS No.	REF. No.	PARTS No.	REF. No.	PARTS No.	REF. No.	PARTS No.	REF. No.
BAA3011A050A	2-1	EF308933	5-37	ET316643	4-TR8	ZS328675	5-24x		
BAA3011A050B	2-2	EF309389	5-36	ET316643	4-TR5	ZS447840	5-27x		
BAA3011A050C	2-3	EF309390	5-38x	ET322244	3-TR13,14	ZS463094	5-29x		
BAA3011A060A	3-1	EF315334	5-39x	ET322244	3-TR9,10	ZW305013	5-31x		
BAA3011A060B	3-2	EI202210	3-IC3	ET322244	3-TR12	ZW305013	6-40x		
BAA3011A060C	3-3	EI202211	3-IC7	ET322244	3-TR16to19	ZW698308	5-25x		
BAA3011A070A	4-1	EI202218	2-IC4	ET322244	3-TR11				
BAA3011A070B	4-2	EI306726	3-IC4	ET323232	3-TR1				
BAA3011A070C	4-3	EI307990	3-IC5	ET323366	4-TR6				
BT300163	5-21x	EI307991	3-IC6	ET618873	2-TR1to5				
BT300165	5-22x	EI315381	3-IC1	EV241323	3-VR1				
BT300177	5-23x	EI315491	2-IC5	EV380215	2-VR1				
BT300185	5-20	EI322185	2-IC2	EV380215	2-VR3				
BT327067	3-T1	EI322248	2-IC1	EV427858	2-VR2				
BT328136	2-T1	EI323247	2-IC3	EV551452	2-VR5to7				
EA202205	5-4x	EI327064	3-IC2	EV618131	2-VR4				
EC201253	2-C66	EI327074	3-X1	EW302995	5-34x				
EC300191	3-VC1	EJ301513	5-19x	EW305691	5-17x				
EC300193	2-C20	EJ315377	3-J3	EW306428	5-16				
EC300193	2-C28	EM202209	3-IND1	EW315767	5-32x				
EC300245	2-C33	EO202215	2-T6	EW322401	5-33x				
EC300254	2-C44	EO202216	2-T7	SA311742	5-28				
EC300448	2-C67	EO307785	2-T4	SB200915A	6-33				
EC314688	4-C29	EO307786	2-T5	SB200915B	6-34x				
EC320548	4-C15,16	EO315401	2-T8	SB316498	6-31				
EC320548	4-C22	EO322241	2-T3	SB316499	6-32x				
EC320548	4-C29	EO325117	2-T8	SE200903A	6-5x				
EC323252	2-C38,39	EO328137	2-L1	SE200903B	6-6x				
EC327382	4-C29	EO328137	3-L1	SE301196A	6-10x				
EC330309	2-C38,39	EO328854	2-T2	SE301196B	6-11x				
EC330310	2-C49	EO485278	3-L2	SE301335A	6-18x				
EC616342	2-VC1	ER315407	2-FL1,2	SE301335B	6-19x				
EC675742	2-VC2	ER318248	2-FR1	SK301221A	6-26				
ED200469	2-D1to8	ER322237	2-FL3	SK301221A	6-12				
ED200469	2-D10,11	ER324184	2-R4	SK301221B	6-13x				
ED200469	2-D15	ER324184	2-R11	SK301221B	6-27x				
ED200469	3-D12	ER324184	2-R17	SK301269A	6-14				
ED200469	3-D14to16	ER324184	2-R35	SK301269B	6-15x				
ED200469	3-D18to20	ER324184	2-R134	SK301369A	6-20				
ED200469	3-D22to29	ER324185	2-R18	SK301369B	6-21x				
ED200469	3-D11	ER324185	2-R52	SK301406A	6-22				
ED200469	3-D8,9	ER324186	4-R9	SK301406B	6-23x				
ED200469	3-D13	ER328855	2-FL4,5	SK301407A	6-24				
ED200469	3-D17	ER669328	4-R14	SK301407B	6-25x				
ED200469	3-D1to5	ES202212	2-SW3	SP200694	5-26x				
ED200469	3-D7	ES202219	2-SW4	SP200921A	6-35				
ED200469	3-D10	ES300194	2-SW3	SP200921B	6-36x				
ED200469	4-D4	ES300264	2-SW1	SP200921C	6-37x				
ED200469	6-8x	ES310839	4-SW1	SP300872A	6-1				
ED223547	4-D5	ES323240	2-SW2	SP300872B	6-21x				
ED224526	3-D6	ES323241	2-SW1	SP300872C	6-3x				
ED224526	4-D7	ES328414	6-7x	SP300872D	6-4x				
ED300257	4-D3	ES328414	6-16x	SP300873A	5-5				
ED306722	4-D2	ES665875	4-SW1	SP300873B	5-6x				
ED322184	5-3x	ET230534	2-TR8	SP300873C	5-7x				
ED322215	5-2x	ET230534	3-TR3	SP300873D	5-8x				
ED322238	4-D1	ET230534	3-TR6	SP300873E	5-9x				
ED322247	5-1x	ET307193	4-TR7	SP300873F	5-10x				
ED322772	6-9	ET307193	4-TR4	SP300873G	5-11x				
ED322773	6-17	ET307193	4-TR2	SZ321494	6-30				
ED323057	2-D14	ET316643	2-TR9to14	SZ631945	5-18				
ED324194	3-D21	ET316643	2-TR6,7	TA200911A	6-28x				
ED324197	2-D12,13	ET316643	2-TR18to21	TA200911B	6-29x				
ED325115	4-D8	ET316643	3-TR7,8	TA202208	5-35				
ED325115	4-D6	ET316643	3-TR15	TA307988	2-TM1				
EE202207	5-14	ET316643	3-TR2	ZS308673	5-13x				
EE307784	5-15x	ET316643	3-TR4,5	ZS319460	5-30				
EE325119	2-4	ET316643	3-TR20,21	ZS319460	5-12				
EF300575	5-41x	ET316643	4-TR3	ZS322570	6-38				
EF300599	5-40x	ET316643	4-TR1	ZS322580	6-39x				

2. MODEL AM-U55/J

PARTS No.	REF. No.	PARTS No.	REF. No.	PARTS No.	REF. No.	PARTS No.	REF. No.	PARTS No.	REF. No.
BAA2007A100B	4-1	ER200746	2-FR3,4	SZ316377	6-24x				
BAA2008A020A	2-2	ER200747	2-FR1,2	SZ321494	6-7				
BAA2008A050A	3-3	ER200939	4-R11	SZ631945	5-27				
BAA2008C070A	2-1	ER300159	2-R29	ZS319460	5-31				
BAA2008C130A	3-1	ER302240	2-R33,34	ZS319460	5-33				
BAA2008C130B	3-2	ER308875	2-R8,9	ZS319460	6-32x				
BDA2008A120A	6-3x	ER316802	3-R23	ZS319460	6-34				
BDA2008A120B	6-4x	ER322591	4-R12	ZS322570	6-30				
BDA2008C120A	6-1	ER322787	2-R35,36	ZS322580	6-31x				
BDA2008C120B	6-2x	ER323074	3-R22	ZS322580	6-33				
BT200792	5-35x	ER324480	3-R9,10	ZS325495	5-45x				
BT202177	5-37x	ER324480	3-R44,45	ZS424056	5-41x				
BT202178	5-36x	ER328067	3-R65	ZS447840	5-46x				
BT202179	5-38x	ER328082	2-R10,11	ZS463353	5-29				
BT202180	5-39x	ER658034	5-16x	ZS65942	5-48x				
BT202181	5-34	ES200797	3-SW1to8	ZW260144	6-14x				
BZA2008A080A	5-1x	ES200798	3-SW9,10	ZW305013	5-32x				
EC200811	2-C24,25	ES202185	5-5	ZW413267	5-40x				
EC200949	2-C14,15	ES310839	5-6						
EC314688	5-11x	ES310839	5-9x						
EC320548	2-C20to23	ES315158	5-7x						
EC320548	2-C32	ES679566	5-8x						
EC320548	3-C37	ET293253	4-TR2						
EC320548	5-10x	ET307195	2-TR1						
EC326583	2-C18,19	ET307195	4-TR1						
EC330307	5-12x	ET307195	4-TR3						
ED200469	2-D1,2	ET310148	2-TR3						
ED200469	2-D8,9	ET322598	2-TR4						
ED200469	3-D2	ET322778	2-TR2						
ED200469	3-D3	EV200936	4-VR1						
ED200749	2-D5	EV200937	4-VR1						
ED201445	2-D7	EV315413	2-VR1						
ED201448	2-D10,11	EV315414	3-VR3						
ED214457	2-D3,4	EV325629	3-VR1						
ED300924	3-D1	EV325630	3-VR2						
ED322247	5-2x	EV329572	3-VR1						
ED322773	5-3x	EW305691	5-26x						
ED322773	5-4x	EW306427	5-25x						
ED557111	2-D6	EW306428	5-24						
EF200952	5-52x	EZ328570	5-42x						
EF200952	5-53x	SA311742	5-47						
EF242605	5-59x	SB200915A	6-8						
EF303348	5-56x	SB200915B	6-9x						
EF306951	5-50	SB322576	6-5						
EF308848	5-57x	SB322577	6-6x						
EF309389	5-54x	SK200645	6-21						
EF325683	5-55x	SK200646	6-22x						
EF326613	5-49	SK200647	6-17x						
EF326613	5-51x	SK200648	6-18x						
EF623125	5-58x	SK200651	6-12						
EF668474	5-60x	SK200652	6-13x						
EI200794	2-IC2	SK200772A	6-15						
EI200795	3-IC3	SK200772B	6-16x						
EI200938	3-IC2	SK200778A	6-19x						
EI200938	4-IC1	SK200778B	6-20x						
EI201446	3-IC1	SP200701A	5-18x						
EI323563	2-IC1	SP200701F	5-17						
EI323564	2-IC3	SP200701G	5-19x						
EI329612	3-IC4	SP200701H	5-20x						
EJ240535	5-22	SP200701J	5-21x						
EJ296853	5-28x	SP200714	5-44x						
EJ316156	5-14x	SP200717A	6-27x						
EJ322582	5-23	SP200717B	6-28x						
EJ323144	5-13	SP202142	5-43x						
EJ326185	5-61	SP202143A	6-25						
EJ329265	5-15x	SP202143B	6-26x						
EJ329610	5-30	SP202143C	6-29x						
EJ330544	4-J1	SZ200770A	6-10x						
EO324220	2-L1	SZ200770B	6-11x						
EP323565	2-RL1	SZ316376	6-23x						

SECTION 4

SCHEMATIC DIAGRAM

1. SCHEMATIC DIAGRAM OF ICs
2. AT-S55 No. 2-1 1621052A TUNER & POWER SCHEMATIC DIAGRAM
3. AT-S55 No. 2-2 1621053A SYNTHESIZER SCHEMATIC DIAGRAM
4. AT-S55L No. 2-1 1621054A TUNER & POWER SCHEMATIC DIAGRAM
5. AT-S55L No. 2-2 1621055A SYNTHESIZER SCHEMATIC DIAGRAM
6. AM-U55 No. 1621050A SCHEMATIC DIAGRAM
7. AM-U55J No. 1621051A SCHEMATIC DIAGRAM

LA1231N

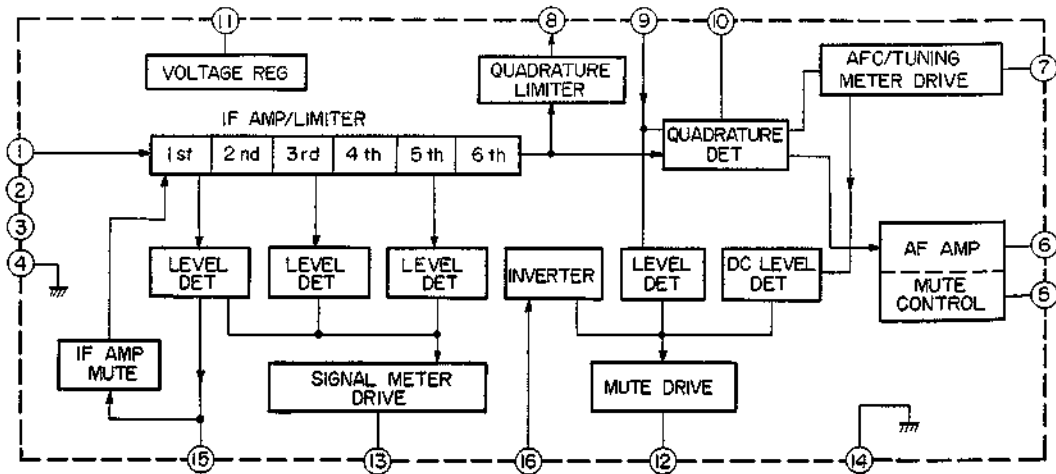

LA1245

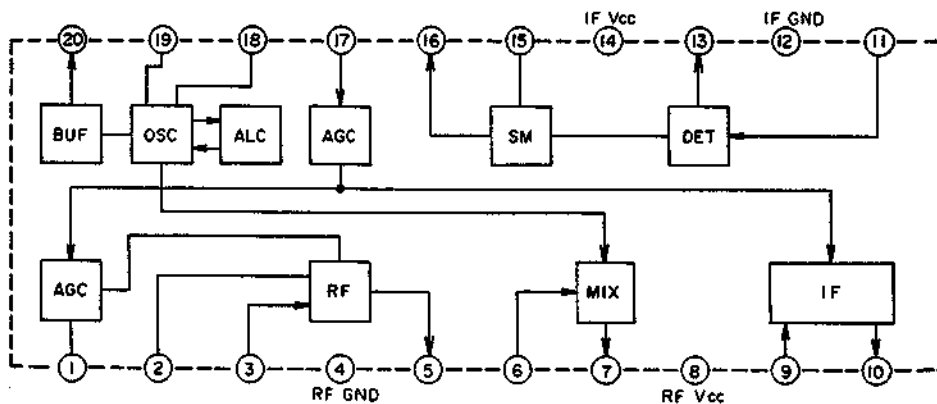

LA3380(B)

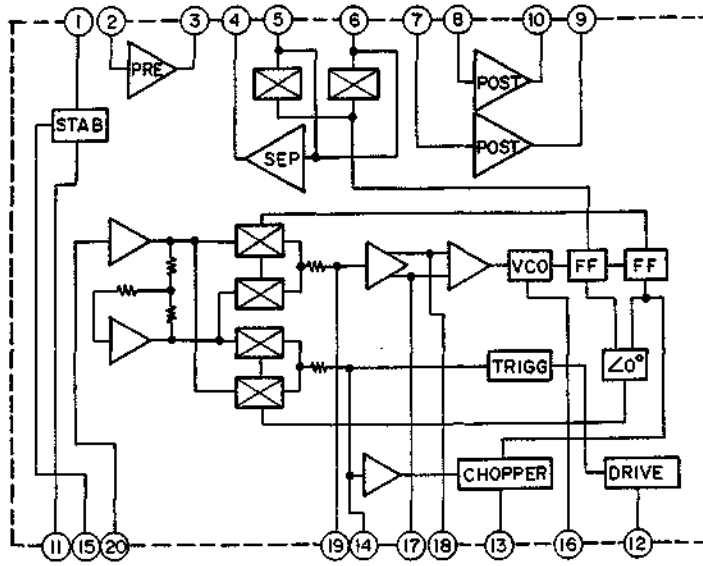

LB1260

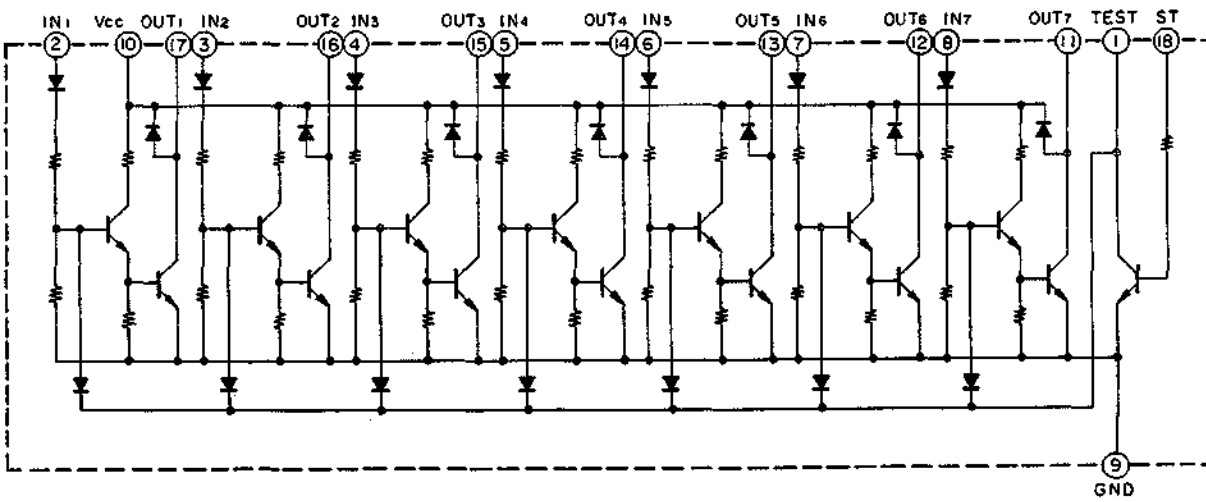

LB1269

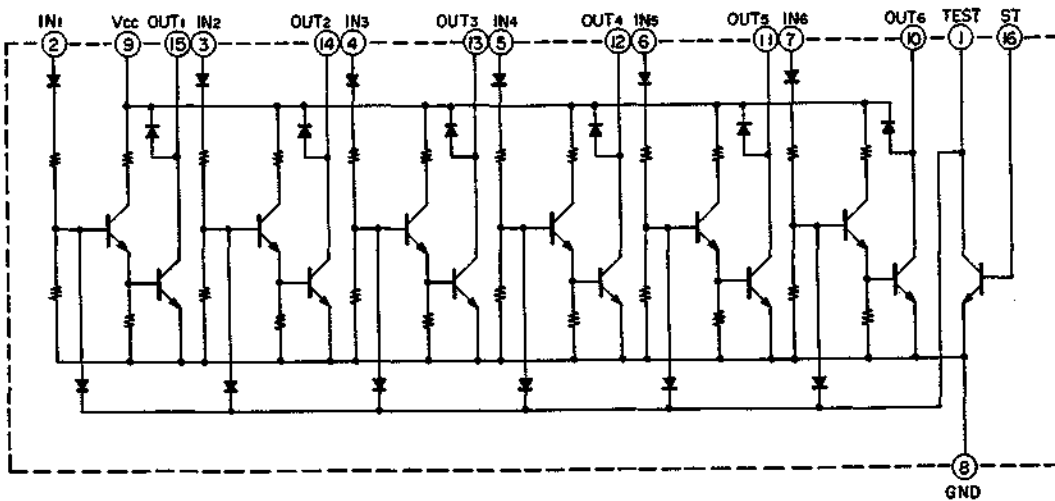

LB1405S

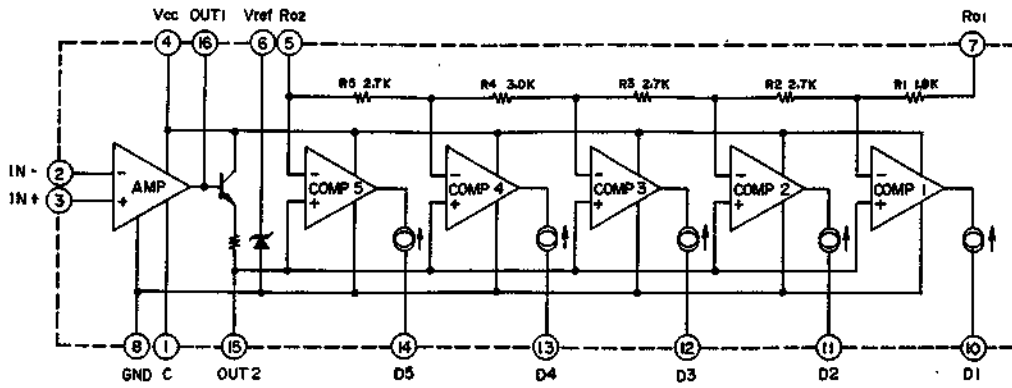

LB1409

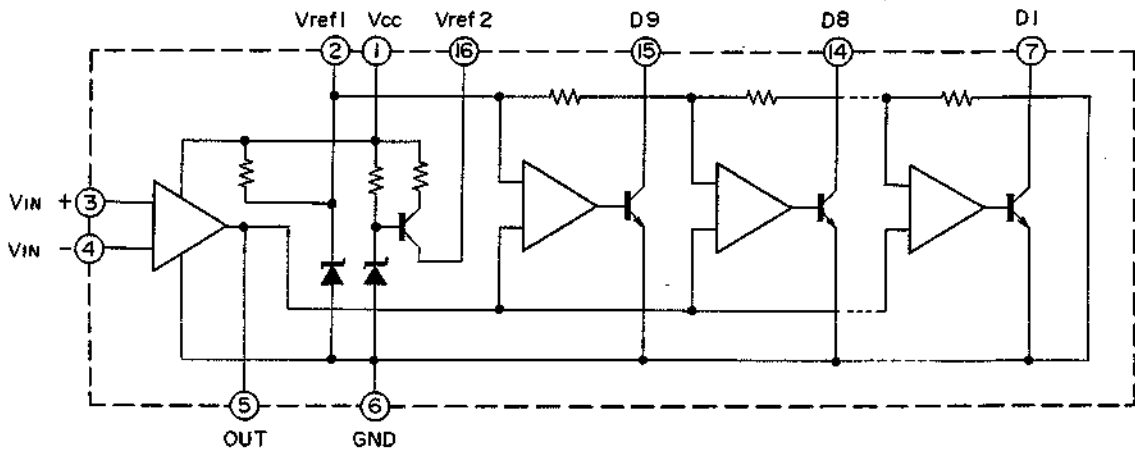

M5213L

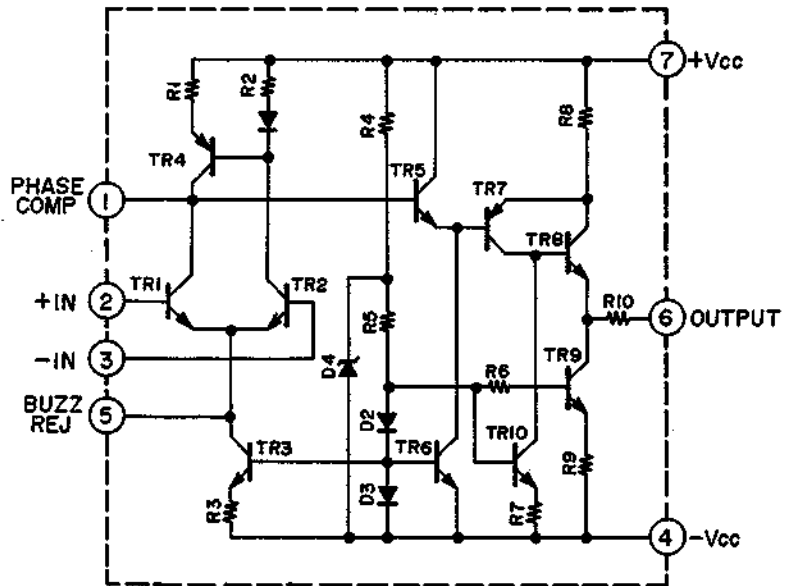

M5214L

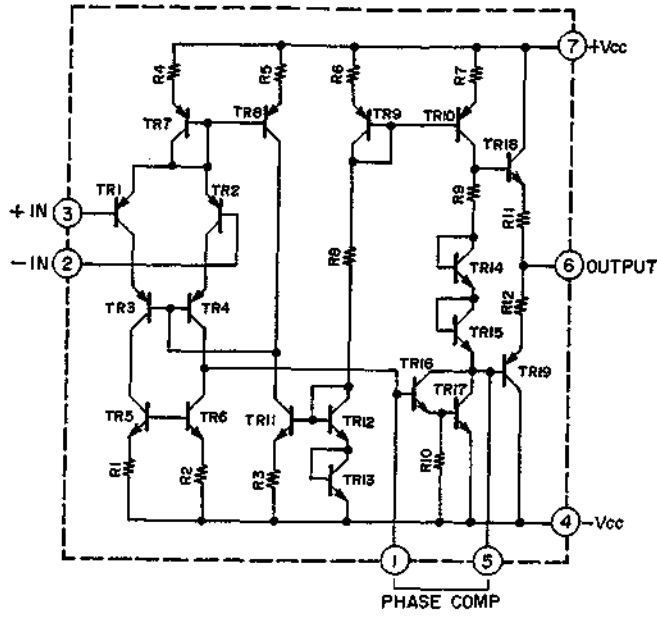

STK-2155

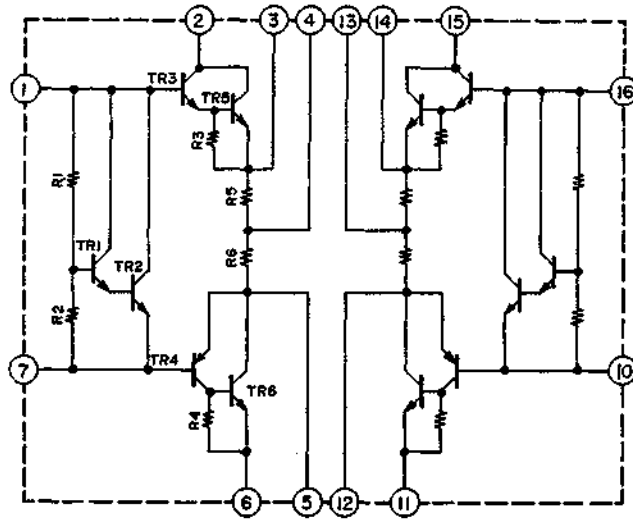

STK-3042

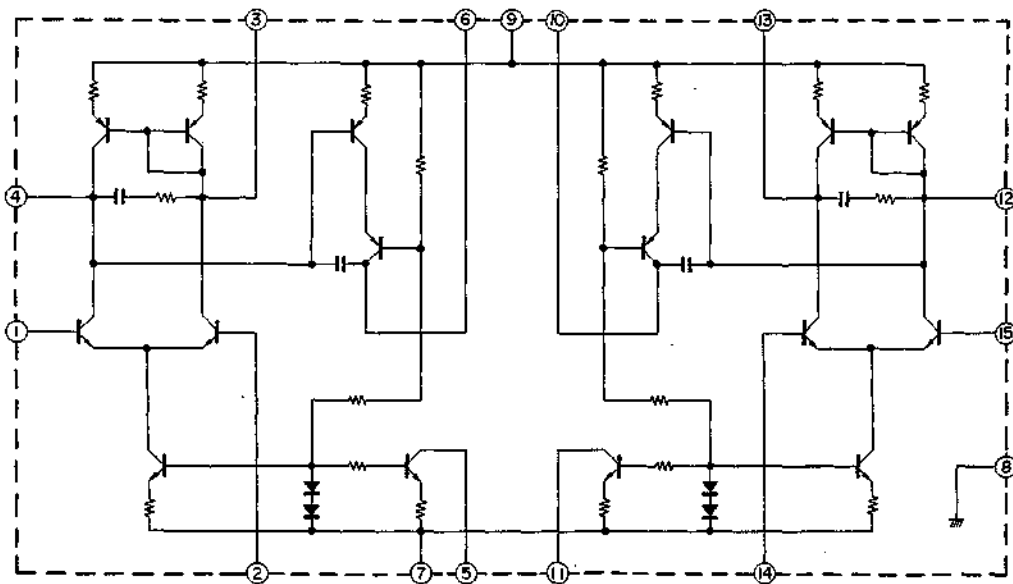

TA7317

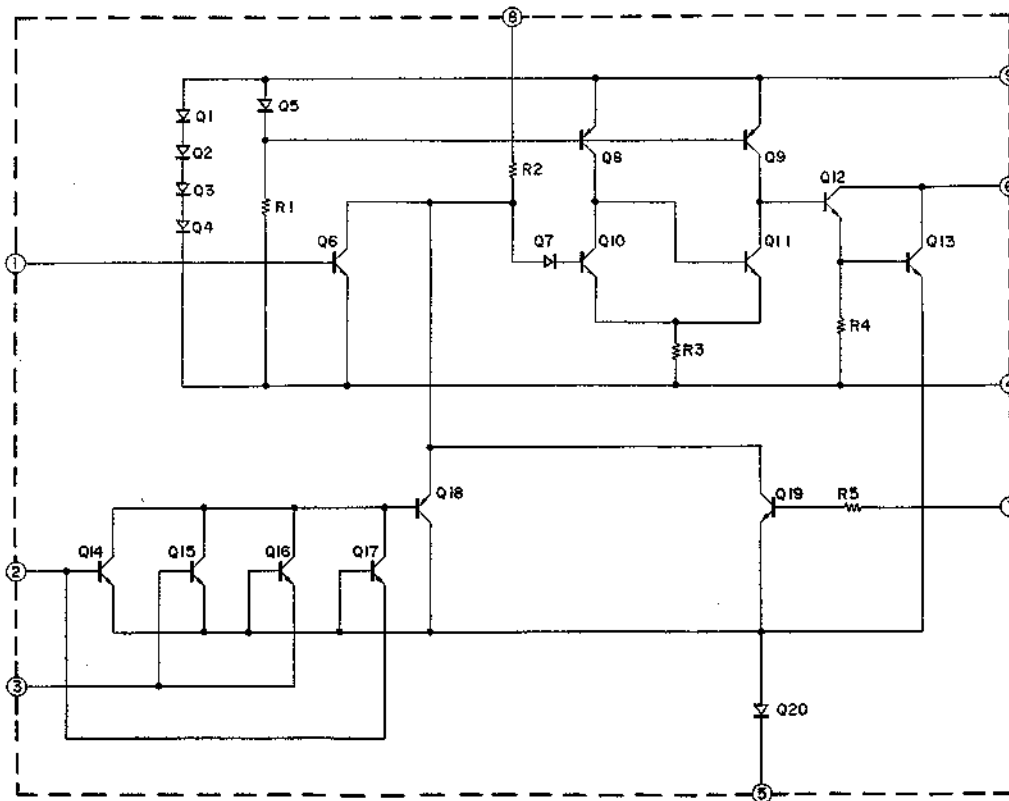
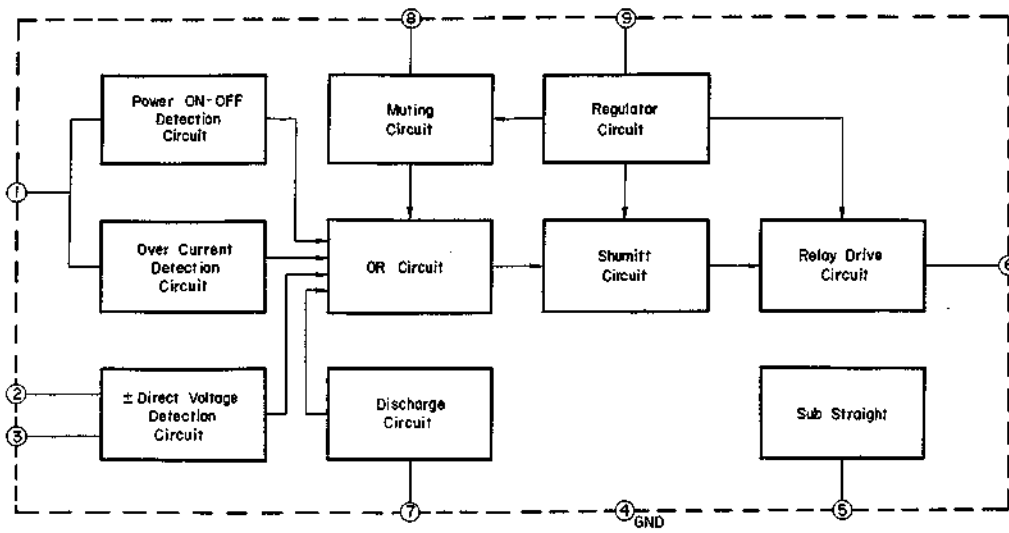

TA7324P

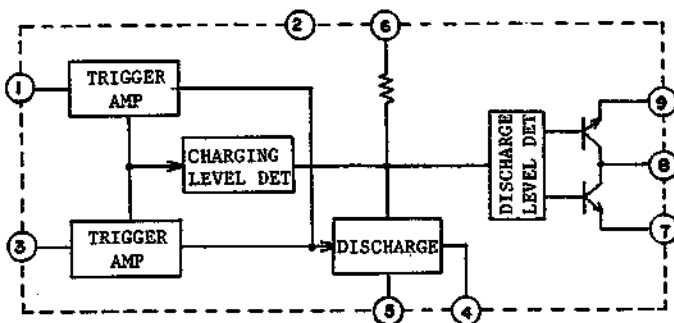

TA75558S

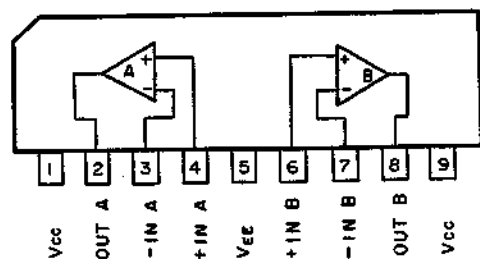

TC4069 UBP

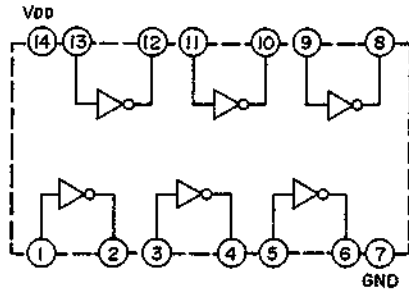

TC9125P

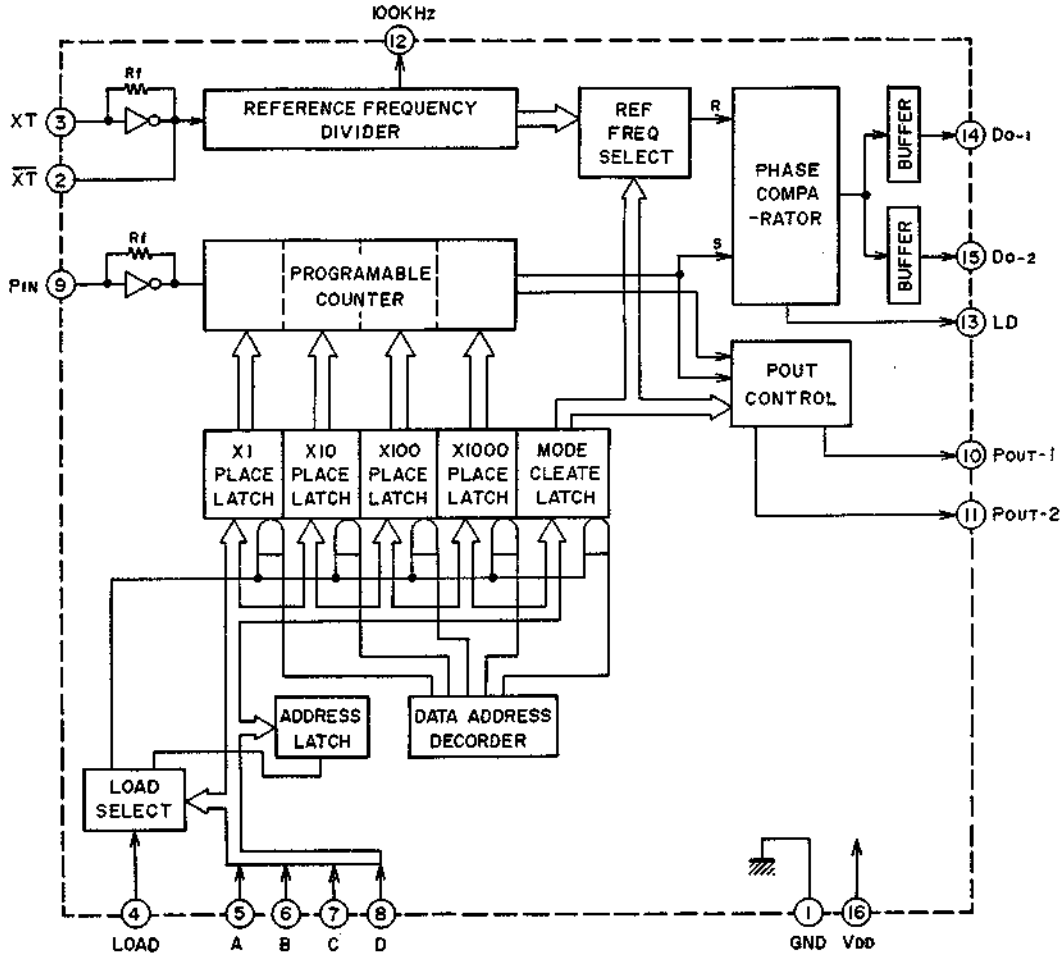

TD6102P

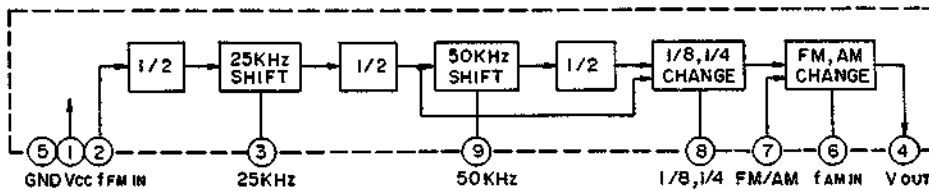

TD62506P

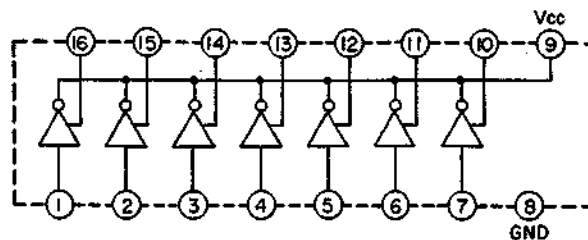

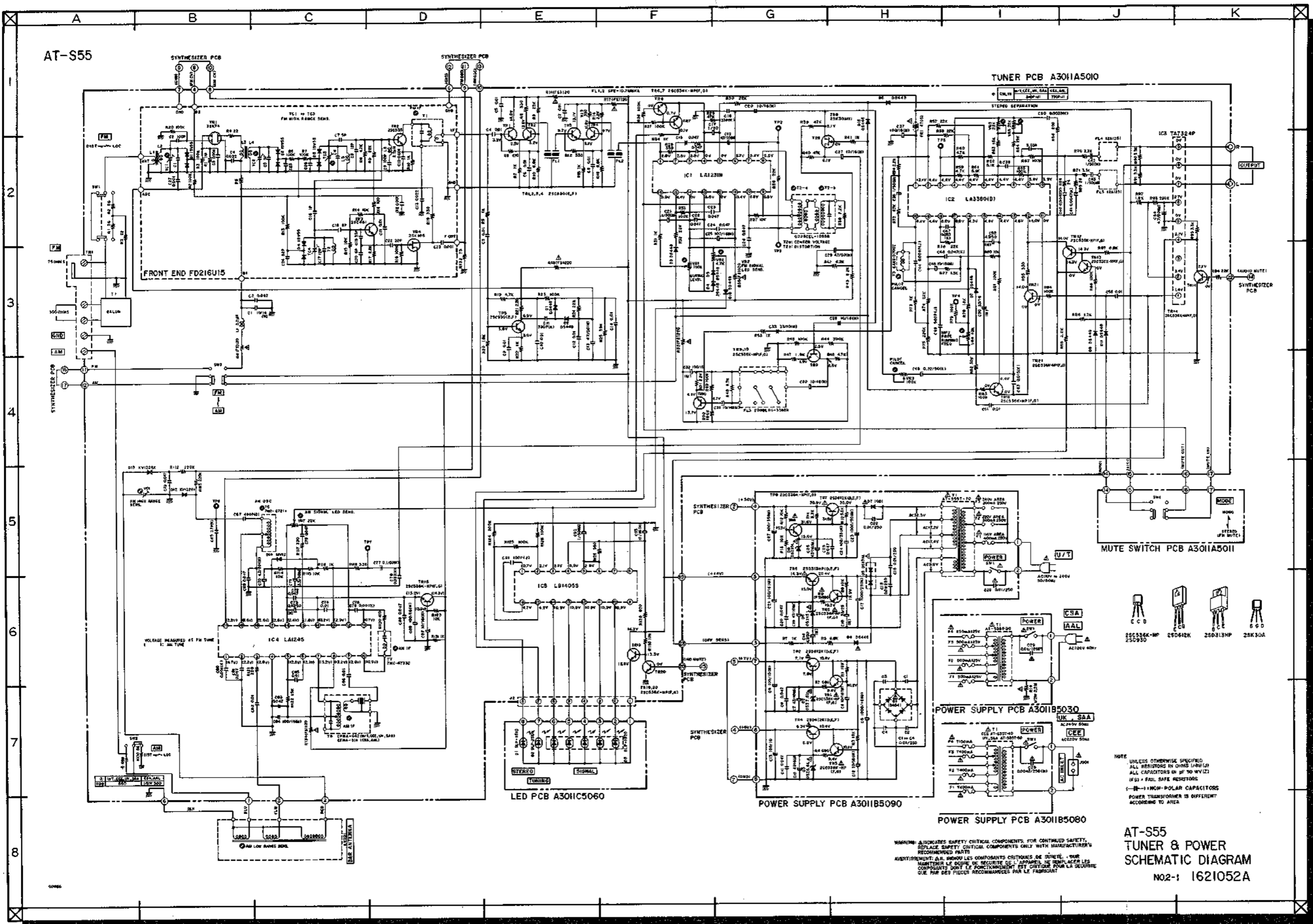

NOTE
UNLESS OTHERWISE SPECIFIED
ALL RESISTORS IN OHMS (UNLESS
ALL CAPACITORS IN μ F 50 WV(2)
IF 50 - FAIL SAFE RESISTORS
- - - - - NON-POLAR CAPACITORS
POWER TRANSFORMER IS DIFFERENT
ACCORDING TO AREA

AT-S55
TUNER & POWER
SCHEMATIC DIAGRAM
N02-1 1621052A

WARNING: INDICATES SAFETY CRITICAL COMPONENTS. FOR CONTINUED SAFETY,
REPLACE SAFETY CRITICAL COMPONENTS ONLY WITH MANUFACTURER'S
RECOMMENDED PARTS
AVERTISSEMENT: A.H. INDIQUE LES COMPOSANTS CRITIQUES DE SECURITE. POUR
MANTENIR LE NIVEAU DE SECURITE DE L'APPAREIL, NE REMPLACEZ LES
COMPOSANTS QU'AVEC LES RECOMMANDATIONS ESTABLIES POUR LA SECURITE
QUE PAR DES PIECES RECOMMANDEES PAR LE FABRICANT

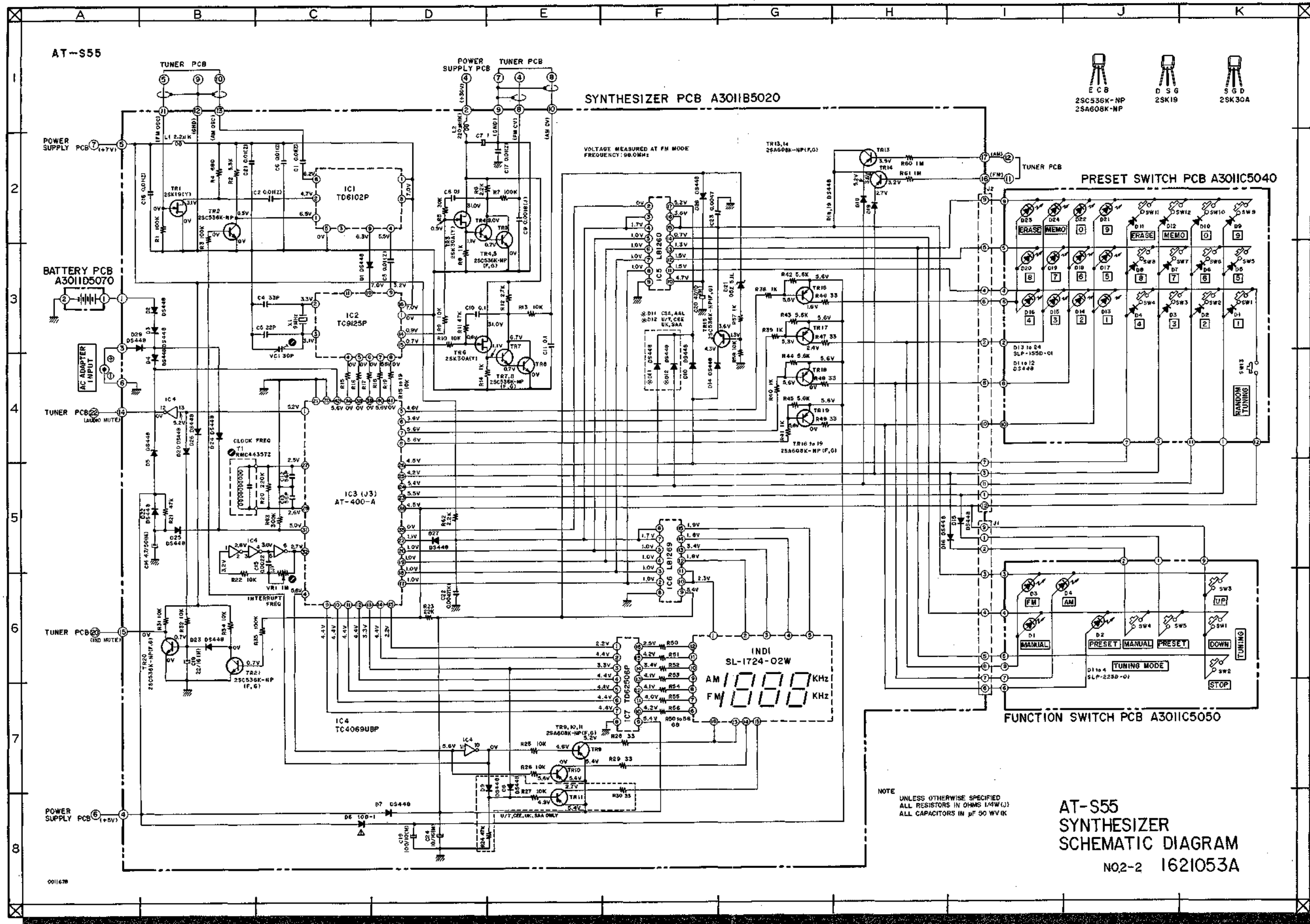

AT-S55L

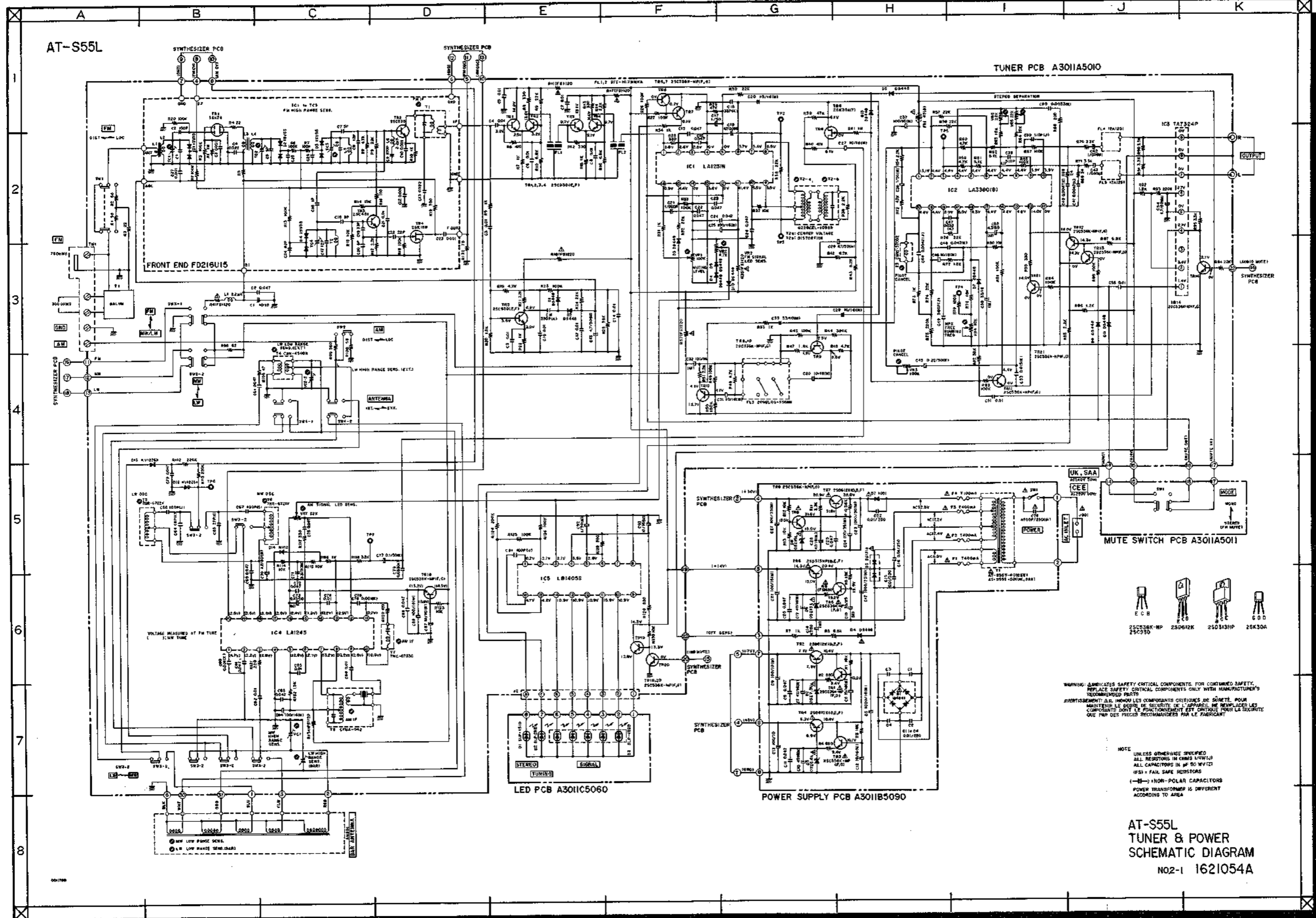

WARNING: AMBIGUOUS SAFETY CRITICAL COMPONENTS. FOR CONTINUED SAFETY, REPLACE SAFETY CRITICAL COMPONENTS ONLY WITH MANUFACTURER'S RECOMMENDED PARTS.
 AVERTISSEMENT: AVOIR UNiquement LES COMPOSANTS CRITIQUES DE SÛRETÉ. POUR MAINTENIR LE DEGRÉ DE SÛRETÉ DE L'APPAREIL, NE REMPLACEZ LES COMPOSANTS QU'EN FONCTIONNEMENT ET CRITIQUES POUR LA SÛRETÉ QUE PAR DES PIÈCES RECOMMANDÉES PAR LE FABRICANT.

NOTE: UNLESS OTHERWISE SPECIFIED, ALL RESISTORS IN OHMS (W/L), ALL CAPACITORS IN P.F. (W/L), (R/S) - FAN SAFE RESISTORS, (—) - NON-POLAR CAPACITORS, POWER TRANSFORMER IS DIFFERENT ACCORDING TO AREA.

AT-S55L
 TUNER & POWER
 SCHEMATIC DIAGRAM
 N02-1 1621054A

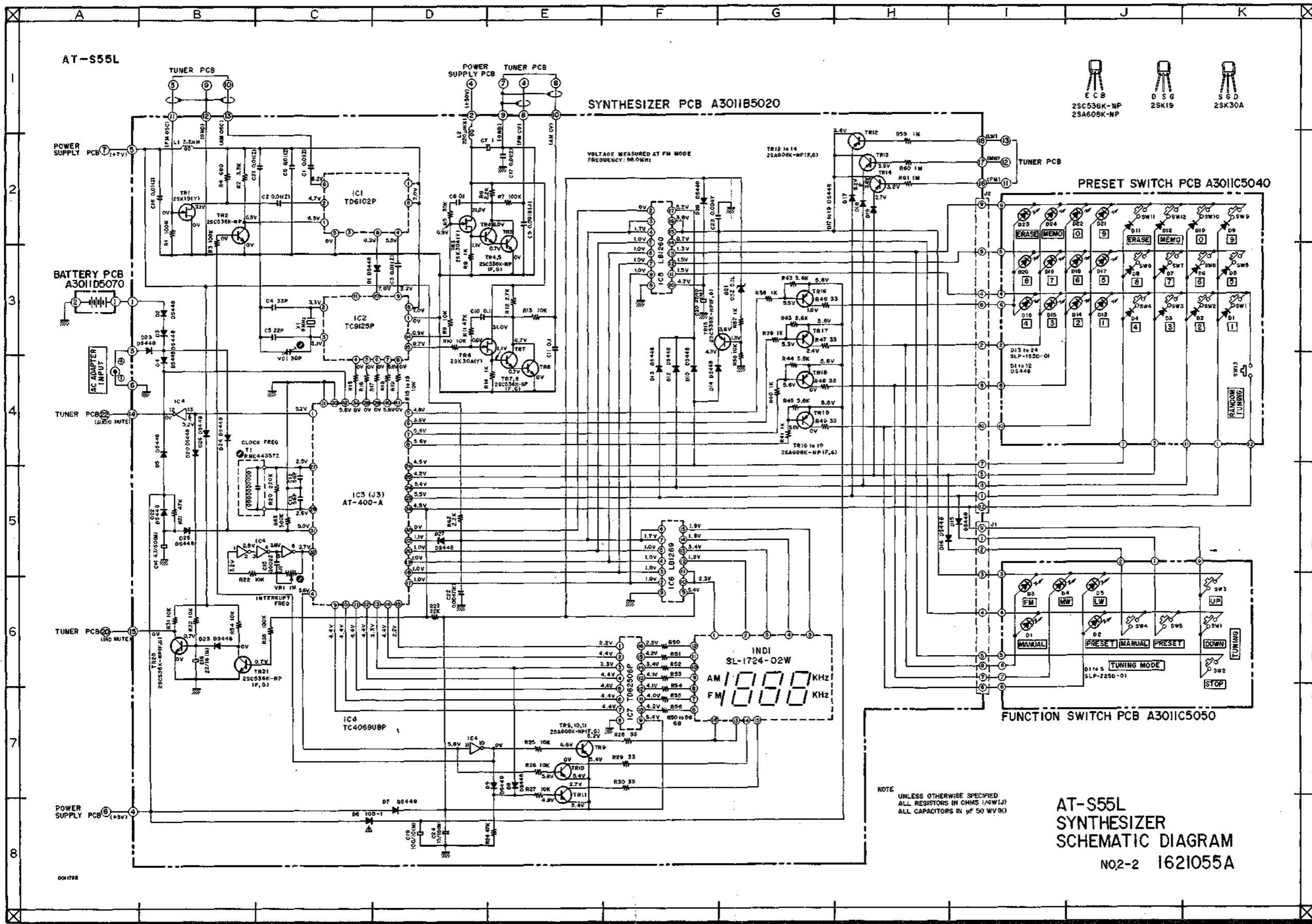

AT-S55L
SYNTHESIZER
SCHEMATIC DIAGRAM
NO2-2 1621055A

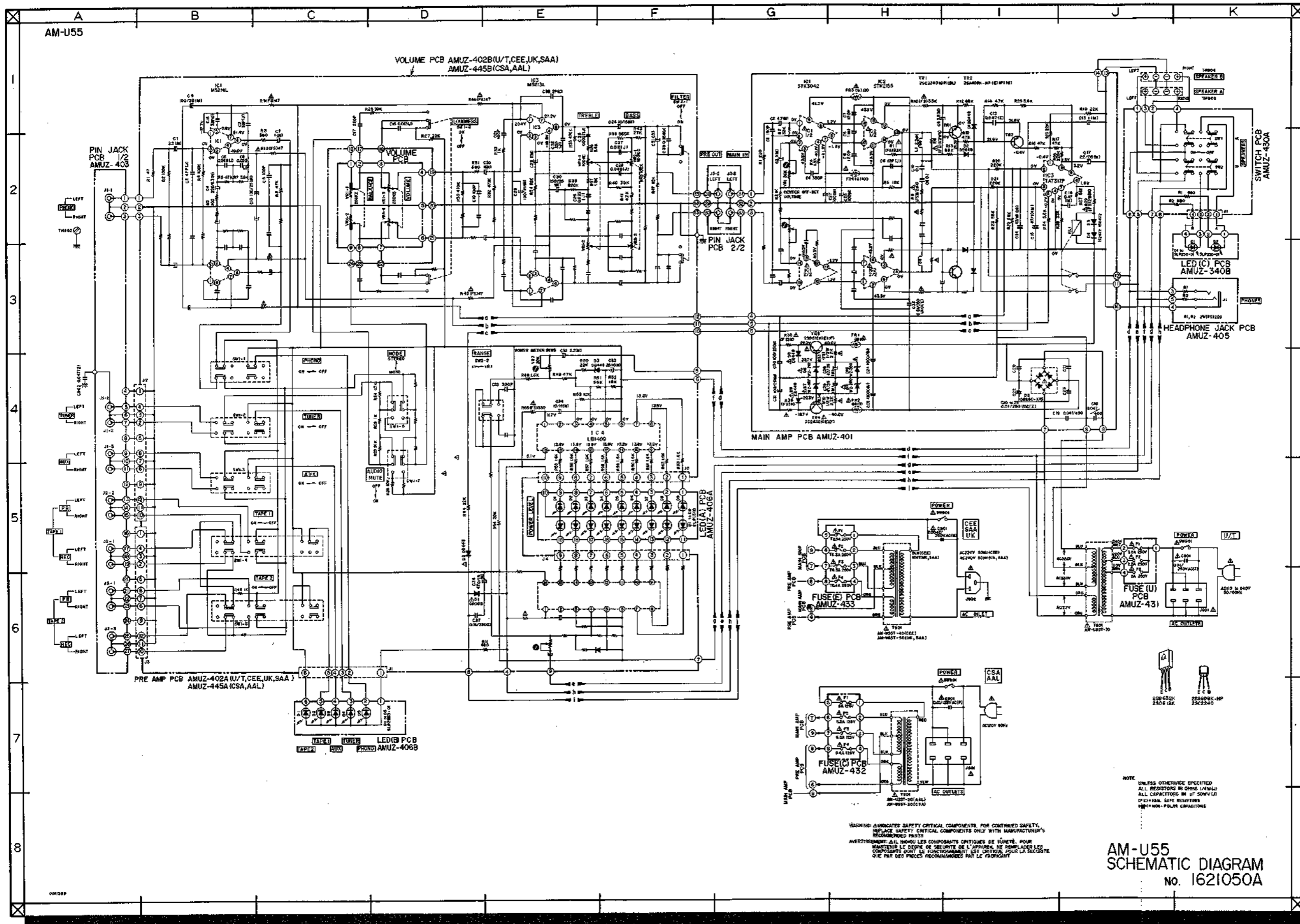

AM-U55
SCHEMATIC DIAGRAM
No. 1621050A

AM-U55J

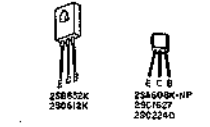
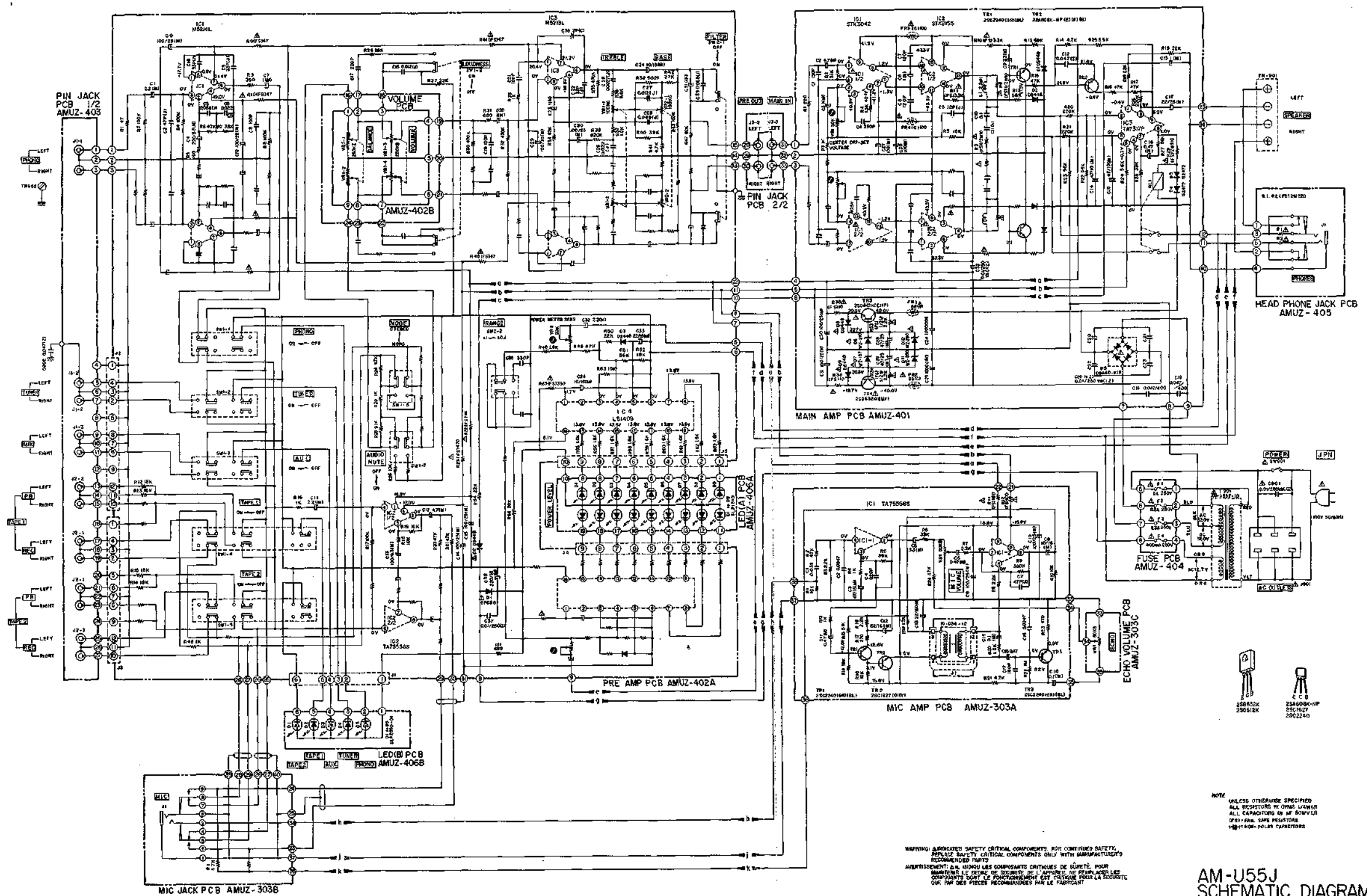

NOTE
UNLESS OTHERWISE SPECIFIED
ALL RESISTORS IN OHMS UNLESS
ALL CAPACITORS IN PF UNLESS
OTHERWISE SPECIFIED
RESISTORS
NON-POLAR CAPACITORS

WARNING: ASSOCIATED SAFETY CRITICAL COMPONENTS. FOR CONTINUED SAFETY,
REPLACE SAFETY CRITICAL COMPONENTS ONLY WITH MANUFACTURER'S
RECOMMENDED PARTS.
AVERTISSEMENT: DES COMPOSANTS CRITIQUES DE SÛRETÉ. POUR
MANTENIR LE DEGRÉ DE SÛRETÉ DE L'APPAREIL, NE REMPLACEZ LES
COMPOSANTS SANS LE FONCTIONNEMENT EST CRITIQUE POUR LA SÛRETÉ
OU PAR DES PIÈCES RECOMMANDÉES PAR LE FABRICANT.

AM-U55J
SCHEMATIC DIAGRAM
NO. 1621051A

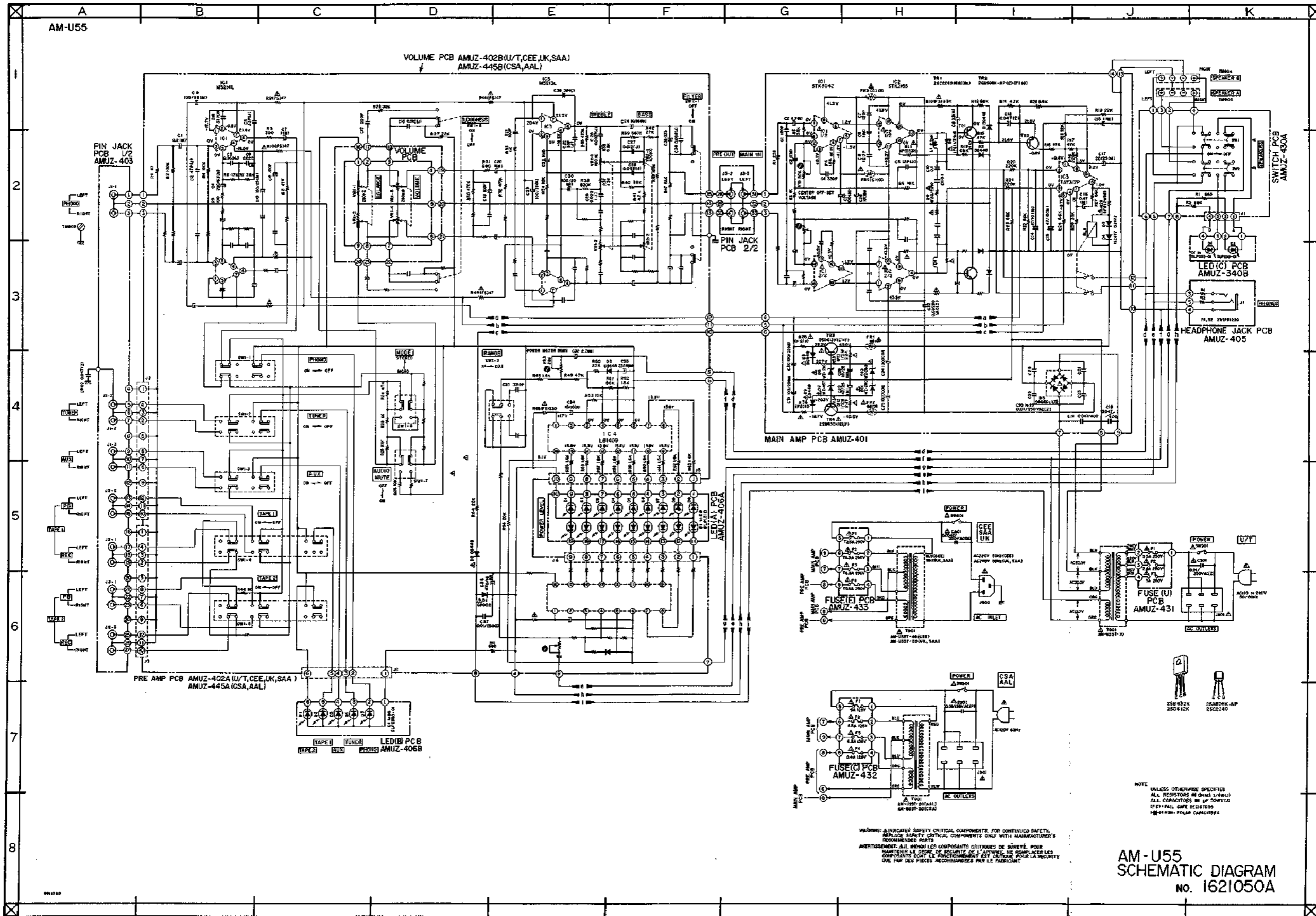

NOTE
UNLESS OTHERWISE SPECIFIED
ALL RESISTORS IN OHMS (Ω/Ω/Ω)
ALL CAPACITORS IN μF (μ/μ/μ)
1% ± 1% TOL. 5% ± 5% TOL.
100-μF POLAR CAPACITORS

WARNING: Δ INDICATES SAFETY CRITICAL COMPONENTS. FOR CONTINUED SAFETY,
REPLACE SAFETY CRITICAL COMPONENTS ONLY WITH MANUFACTURER'S
RECOMMENDED PARTS
AVERTISSEMENT: Δ IL INDICATE LES COMPOSANTS CRITIQUES DE SÉCURITÉ. POUR
MAINTENIR LE NIVEAU DE SÉCURITÉ DE L'APPAREIL, NE REMPLACEZ LES
COMPOSANTS QU'AVEC LE FONCTIONNEMENT EST OBTENU POUR LA SÉCURITÉ
DES PIÈCES RECOMMANDÉES PAR LE FABRICANT

AM-U55
SCHEMATIC DIAGRAM
No. 1621050A