

AT-K02  
AM-U02

# AKAI SERVICE MANUAL

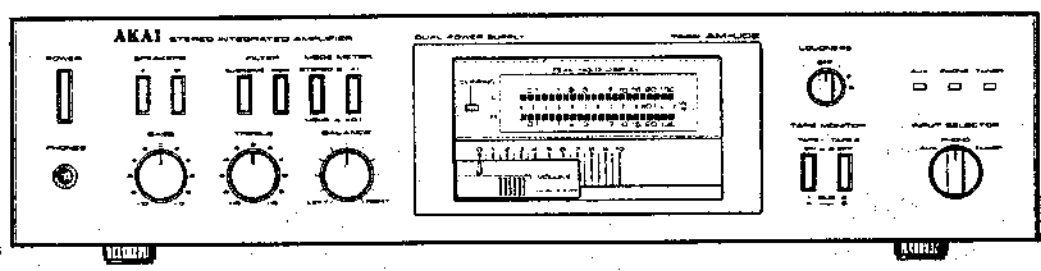
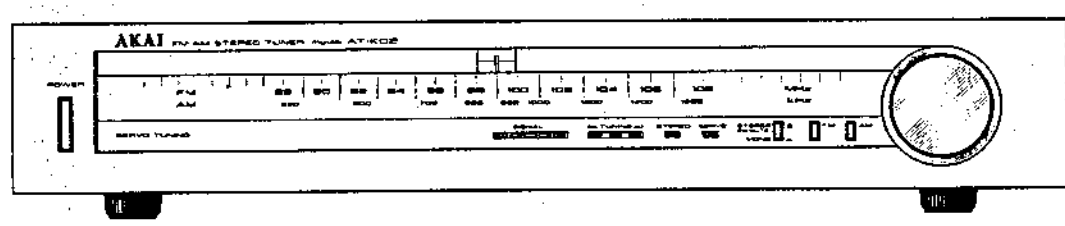

FM AM STEREO TUNER

## MODEL AT-K02

STEREO INTEGRATED AMPLIFIER

## MODEL AM-U02

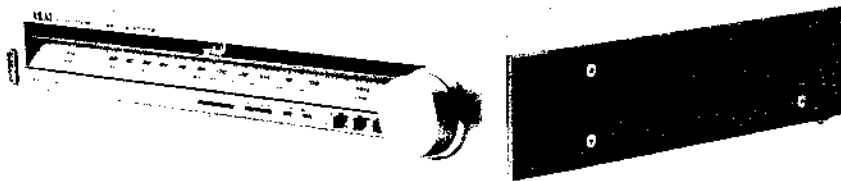

AT-K02



AM-U02

**FM AM STEREO TUNER**  
**MODEL AT-K02**  
**STEREO INTEGRATED AMPLIFIER**  
**MODEL AM-U02**

**ALSO APPLICABLE TO BLACK PANEL MODEL**

SECTION 1	MODEL AT-K02 SERVICE MANUAL	3
SECTION 2	MODEL AM-U02 SERVICE MANUAL	15
SECTION 3	PARTS LIST	31
SECTION 4	SCHEMATIC DIAGRAM	45

---

SECTION 1

**MODEL AT-K02**

**SERVICE MANUAL**

TABLE OF CONTENTS

I.	TECHNICAL DATA .....	4
II.	DISMANTLING OF UNIT .....	5
III.	CONTROLS .....	6
IV.	PRINCIPAL PARTS LOCATION .....	7
V.	VOLTAGE CONVERSION .....	8
VI.	TUNER ADJUSTMENT .....	9
	1. FM TUNER SECTION ADJUSTMENT .....	10
	2. AM TUNER SECTION ADJUSTMENT .....	11
VII.	TUNING CORD THREADING .....	12
VIII.	CLASSIFICATION OF VARIOUS P.C BOARDS .....	12
	1. P.C BOARD TITLES AND IDENTIFICATION NUMBERS .....	12
	2. COMPOSITION OF VARIOUS P.C BOARDS .....	13

For basic adjustments, measuring methods, and operating principles, refer to GENERAL TECHNICAL MANUAL.

## I. TECHNICAL DATA

### FM TUNER SECTION

FREQUENCY RANGE	87.5 MHz to 108 MHz	
SENSITIVITY (IHF)	1.9 $\mu$ V	
CAPTURE RATIO	1.2 dB	
SELECTIVITY (IHF)	More than 65 dB	
IMAGE REJECTION	More than 60 dB (98 MHz)	
IF REJECTION	More than 85 dB (98 MHz)	
SPURIOUS REJECTION	More than 85 dB (98 MHz)	
AM SUPPRESSION	60 dB	
SIGNAL TO NOISE RATIO	73 dB	
HARMONIC DISTORTION	MONO STEREO	Less than 0.09% (100% modulation) Less than 0.12% (100% modulation)
TUNING INDICATOR	3 LEDs	
SIGNAL INDICATOR	5 LEDs	
MUTING	Switchable to ON-OFF	
STEREO SEPARATION	More than 52 dB (1 kHz)	
SUB CARRIER SUPPRESSION	More than 60 dB	
OUTPUT VOLTAGE	Fixed 1 V (100% modulation)	
ANTENNA INPUT IMPEDANCE	300 ohms balanced, 75 ohms unbalanced	

### AM TUNER SECTION

FREQUENCY RANGE	520 kHz to 1,605 kHz
SENSITIVITY (IHF)	150 $\mu$ V/m (bar antenna), 10 $\mu$ V (external antenna)
SELECTIVITY (IHF)	More than 30 dB
IMAGE REJECTION	More than 55 dB (1,000 kHz)
IF REJECTION	More than 40 dB
SIGNAL TO NOISE RATIO	More than 55 dB
OUTPUT VOLTAGE	300 mV (30% modulation)
ANTENNA	Built-in ferrite bar antenna

### MISCELLANEOUS

SEMICONDUCTORS	Transistors: 26, Diodes: 13, LED: 6, ICs: 4
POWER REQUIREMENTS	120 V, 60 Hz for U.S.A. and Canada 220 V, 50 Hz for Europe except UK 240 V, 50 Hz for UK and Australia 110/220/240 V, 50/60 Hz internally switchable for the other countries
POWER CONSUMPTION	20 W
DIMENSIONS	440 (W) x 78 (H) x 340 (D) mm (17.3 x 3.1 x 13.4) inches
WEIGHT	4.9 kg (10.8 lbs)

\* For improvement purposes, specifications and design are subject to change without notice.

## II. DISMANTLING OF UNIT

In case of trouble, etc. necessitating dismantling, please dismantle in the order shown in the Photographs. Reassemble in reverse order.

1

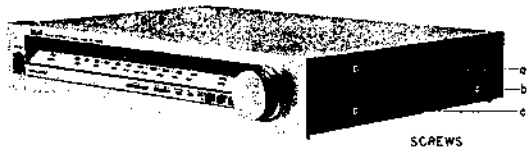

5

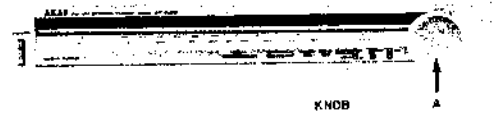

2

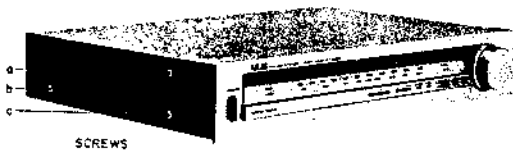

6

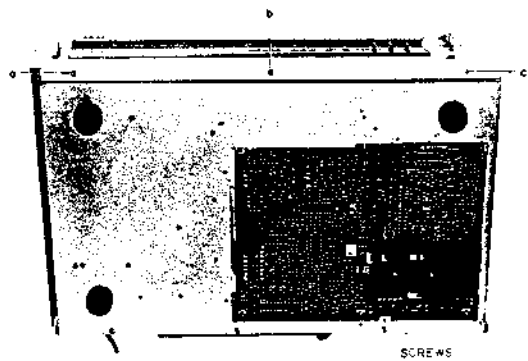

3

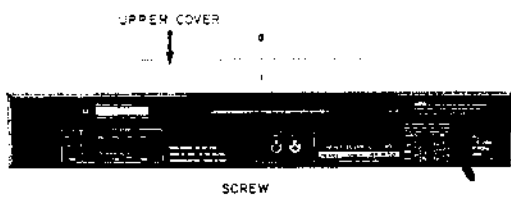

7

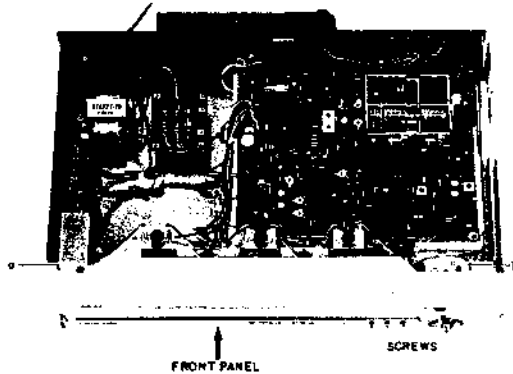

4

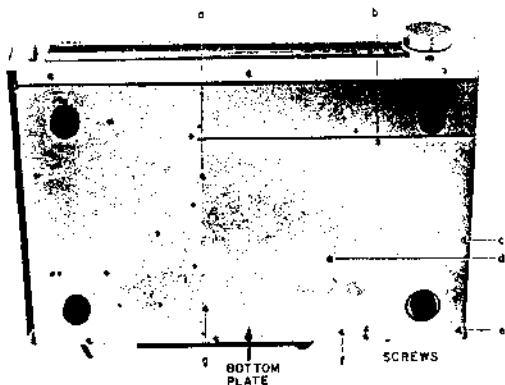

8

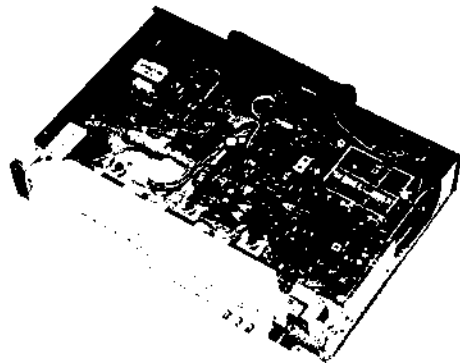

### III. CONTROLS

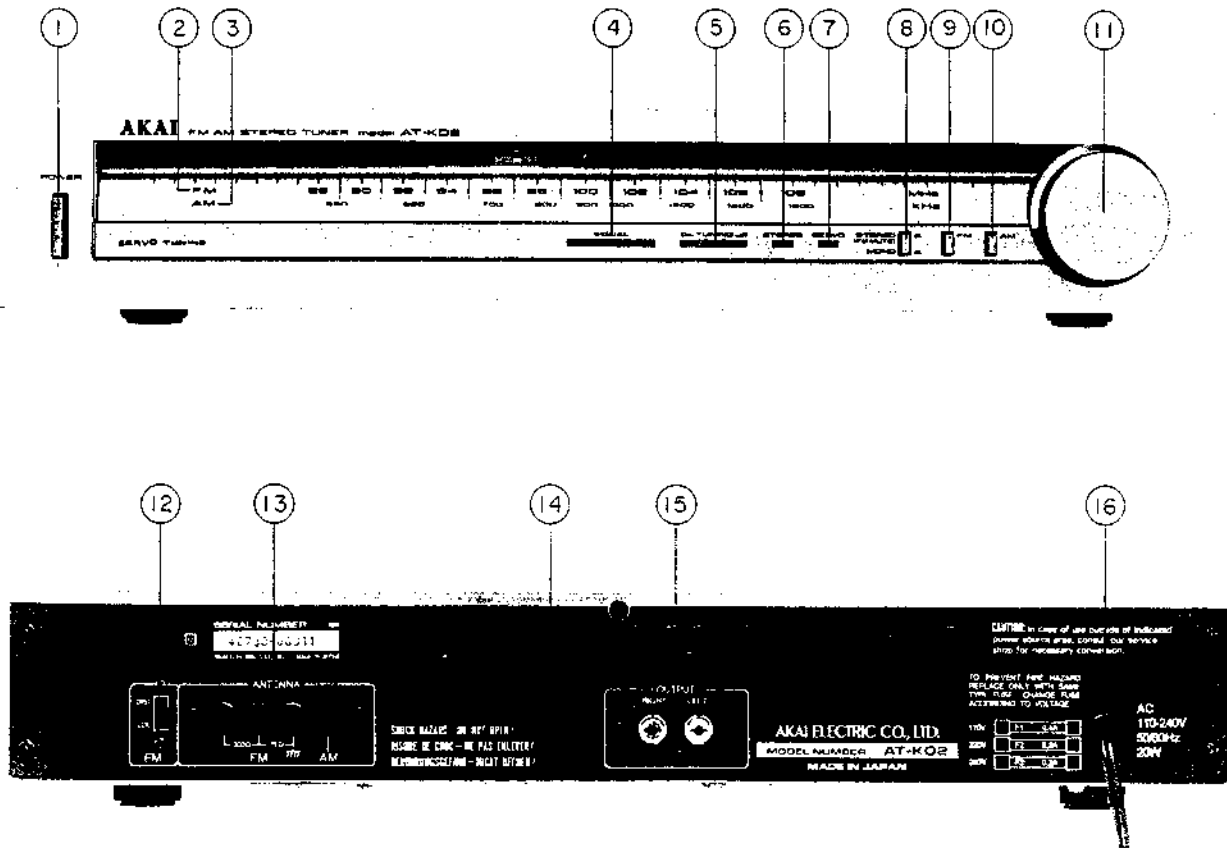

Fig. 1 Controls

- |                               |  |
|-------------------------------|--|
| 1. POWER SWITCH               | 9. FM SWITCH   |
| 2. FM DIAL SCALE              | 10. AM SWITCH  |
| 3. AM DIAL SCALE              | 11. TUNING KNOB  |
| 4. SIGNAL STRENGTH INDICATOR  | 12. FM LOC SWITCH  |
| 5. FM CENTER TUNING INDICATOR | 13. FM and AM ANTENNA TERMINALS                              |
| 6. FM STEREO LAMP             | 14. AM FERRITE BAR ANTENNA                                   |
| 7. FM SERVO LAMP              | 15. OUTPUT JACKS (Left and Right)                            |
| 8. FM MODE SWITCH             | 16. POWER CORD (Some models have power cord inlets instead.) |

# IV. PRINCIPAL PARTS LOCATION

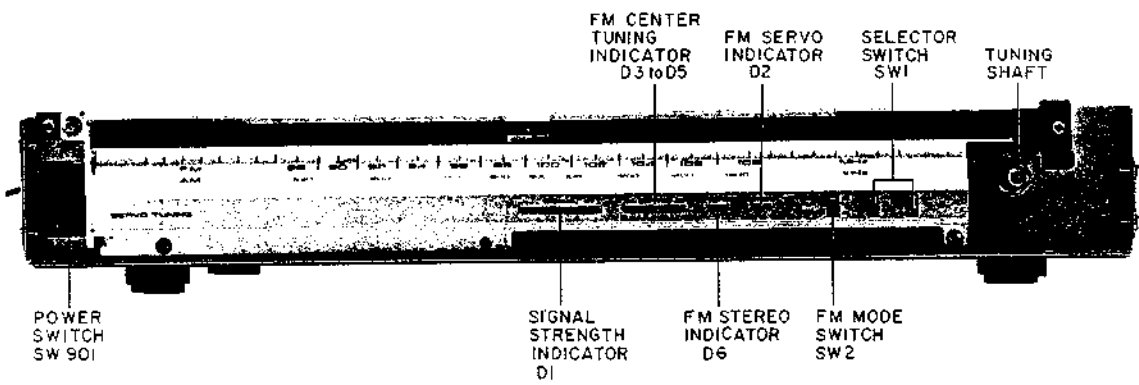

Fig. 2 Front View

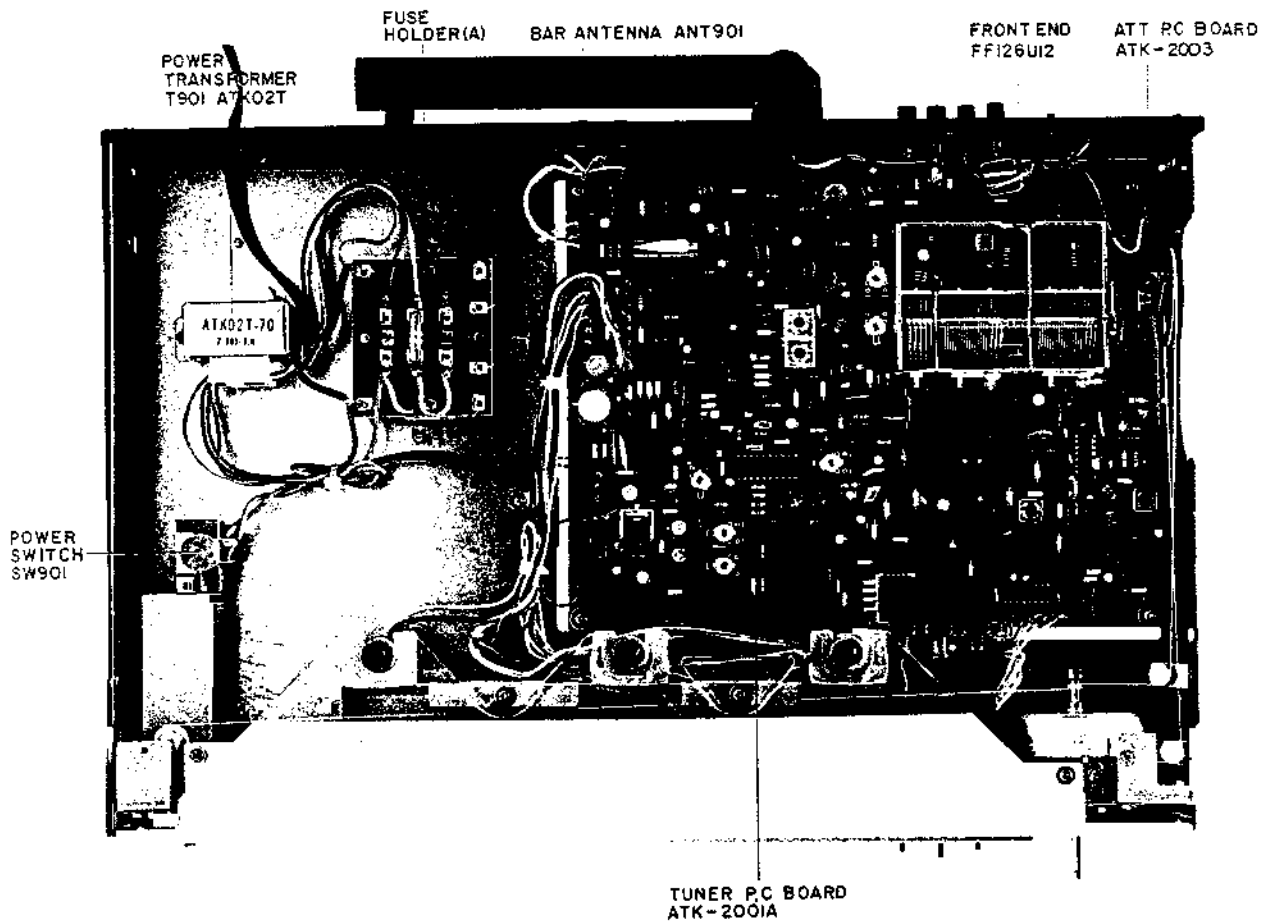

Fig. 3 Top View

## V. VOLTAGE CONVERSION

---

110V AREAS : F1 400mA  
220V AREAS : F2 200mA  
240V AREAS : F3 200mA

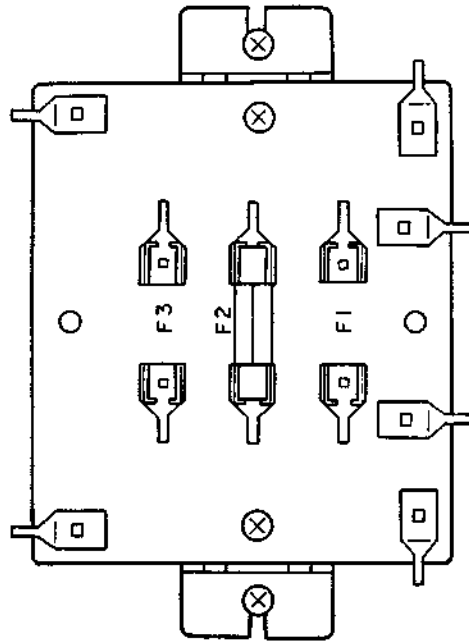
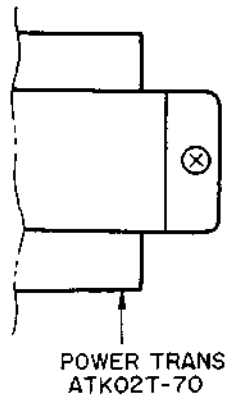

Fig. 4 Fuse Holder (A) (U/T Model)

Models for Canada, USA, Europe, UK and Australia are not equipped with this facility.

Each machine is preset at the factory according to destination but some machines can be set to 110V, 220V or 240V as required.

If voltage change is necessary, this can be accomplished as follows.

- 1) Disconnect AC Power Cord.
- 2) Loosen holding screws and remove upper case.
- 3) Remove existing line voltage fuse in proper fuse holder, explicitly following instructions printed on the rear panel.



# VI. TUNER ADJUSTMENT

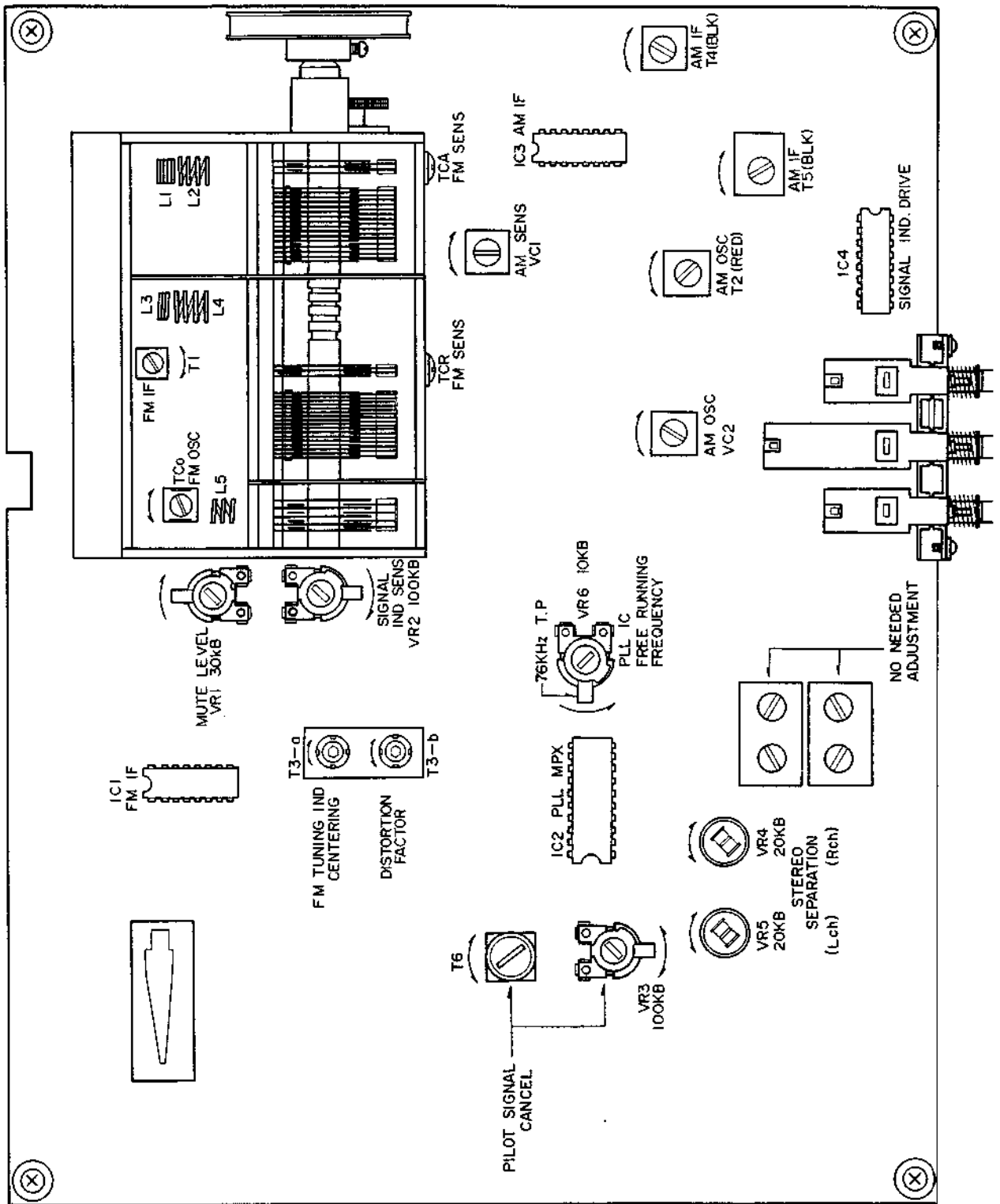

Fig. 5 Tuner P.C Board ATK-301A

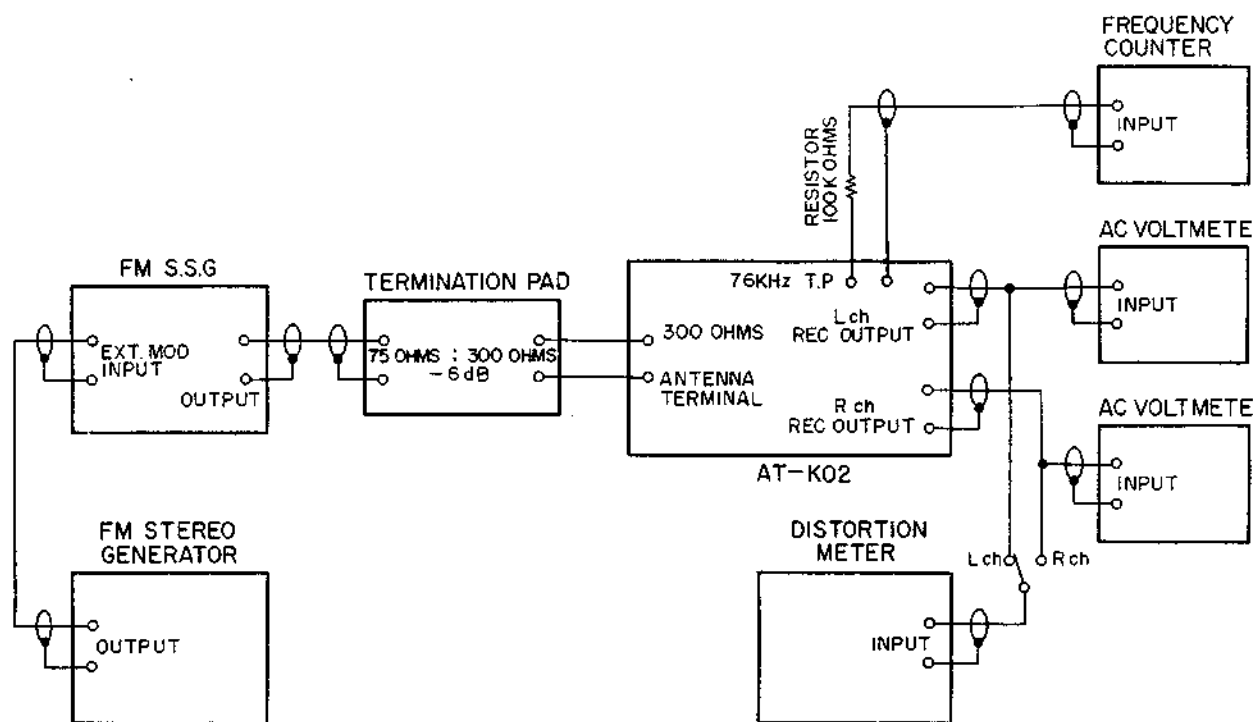

Fig. 6 Instrument Connections

### 1. FM TUNER SECTION ADJUSTMENT (Refer to Figs. 5, 6)

Step	Adjustment Item	Adjustment Point	Result	Remarks
1	Front End IF Coil	T1 (Front End)	Maximum Noise Level	Selector to FM, and Mode to MONO. Tune in noise only without broadcast interference.
2	Tuning indicator Centering	T3-a	Center indication of tuning LEDs	98 MHz, 60 dB (mono) input.
3	Distortion Factor	T3-b	Less than 0.09% Distortion Factor	98 MHz, 60 dB (mono) input. Less than 0.09% in both channels.
4	Confirmation of Tuning indicator Centering			If Tuning indicator is not centered, re-adjust Steps 2 and 3 above.
5	High Range Scale indication	TC0 (Front End)	Maximum output Minimum Distortion Factor	108 MHz, 60 dB (mono) input. Scale indicator to 108 MHz. Error: Within $\pm 250$ kHz
6	Confirmation of Low Range Scale indication		Maximum output Minimum Distortion Factor	88 MHz, 60 dB (mono) input. Scale indicator to 88 MHz. Error: Within $\pm 250$ kHz
7	High Range Sensitivity	TCR, TCA (Front End)	Less than 3% Distortion Factor	108 MHz, Less than 6 dB (mono) input.
8	Confirmation of Low Range Scale indication		Less than 3% Distortion Factor	88 MHz, Less than 6 dB (mono) input. Refer to NOTES 2, 3.
9	Mute level	VR1 30 k $\Omega$	No Signal emitted from output	Mode to STEREO. 98 MHz, 22 dB (mono) input.

10	PLL IC Free Running Frequency	VR6 10 kB	76.00 kHz	Frequency Counter to Test Point. Refer to NOTES 4, 5.
11	Confirmation of Stereo indicator Lighting			98 MHz, 60 dB (stereo) input. No lighting of stereo indicator indicates no stereo separation.
12	Pilot Signal Cancel	VR3 100 kB L6	Minimum output	98 MHz, 60 dB (stereo) pilot signal only input.
13	Stereo Separation (Left → Right)	VR5 20 kB	More than 52 dB	98 MHz, 60 dB (stereo) Lch input. Minimum output of Rch.
14	Stereo Separation (Right → Left)	VR4 20 kB	More than 52 dB	98 MHz, 60 dB (stereo) Rch input. Minimum output of Lch.
15	Signal indicator Sensitivity	VR2 100 kB		98 MHz, 50 dB (mono) input. Adjust VR2 to a point where 5th LED of SIGNAL INDICATOR lights up. Refer to NOTE 6.

Chart-1

- NOTES:
1. Set the FM ANTENNA ATT. switch to DIST.
  2. When the specified sensitivity of 6 dB cannot be obtained at the two frequency points, 88 MHz and 108 MHz repeat adjustment as in Step 7.
  3. When the distortion factor of the sensitivity still does not comply with the data specifications, adjust by turning the Front End FM IF coil (T1) core but not more than 1/2 turn.
  4. When connecting a frequency counter, connect from TP via a 100 kohms resistor.
  5. The free Running Frequency of the PLL IC must be an exactly 76.00 kHz.
  6. The 5th LED lights up at 50 dB but when the attenuator is decreased 2 dB it is extinguished.

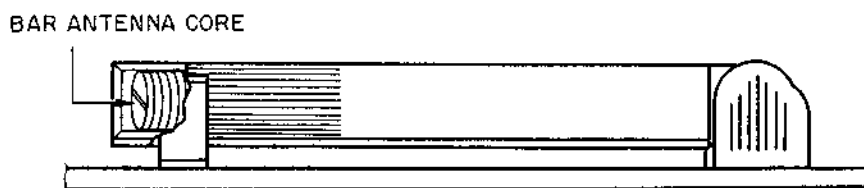

Fig. 7 Bar Antenna

## 2. AM TUNER SECTION ADJUSTMENT (Refer to Figs. 5, 7)

Step	Adjustment Item	Adjustment Point	Result	Remarks
1	Low Range Scale indication	T2 (RED)	Maximum Output	Selector to AM. 530 kHz 50 dB input. Error: Within 2%
2	Low Range Sensitivity	T4 (BLK) T5 (BLK) Bar Antenna Core	Maximum Output Minimum Distortion Factor	530 kHz 50 dB input. Less than 10% Distortion Factor
3	High Range Scale indication	VC 2	Maximum Output	1,600 kHz 50 dB input. Error: Within 2%
4	High Range Sensitivity	VC 1	Maximum Output Minimum Distortion Factor	1,600 kHz 50 dB input. Less than 10% Distortion Factor

Chr t-2

NOTE: For best results, repeat Steps 1 through 4 two or three times.

## VII. TUNING CORD THREADING

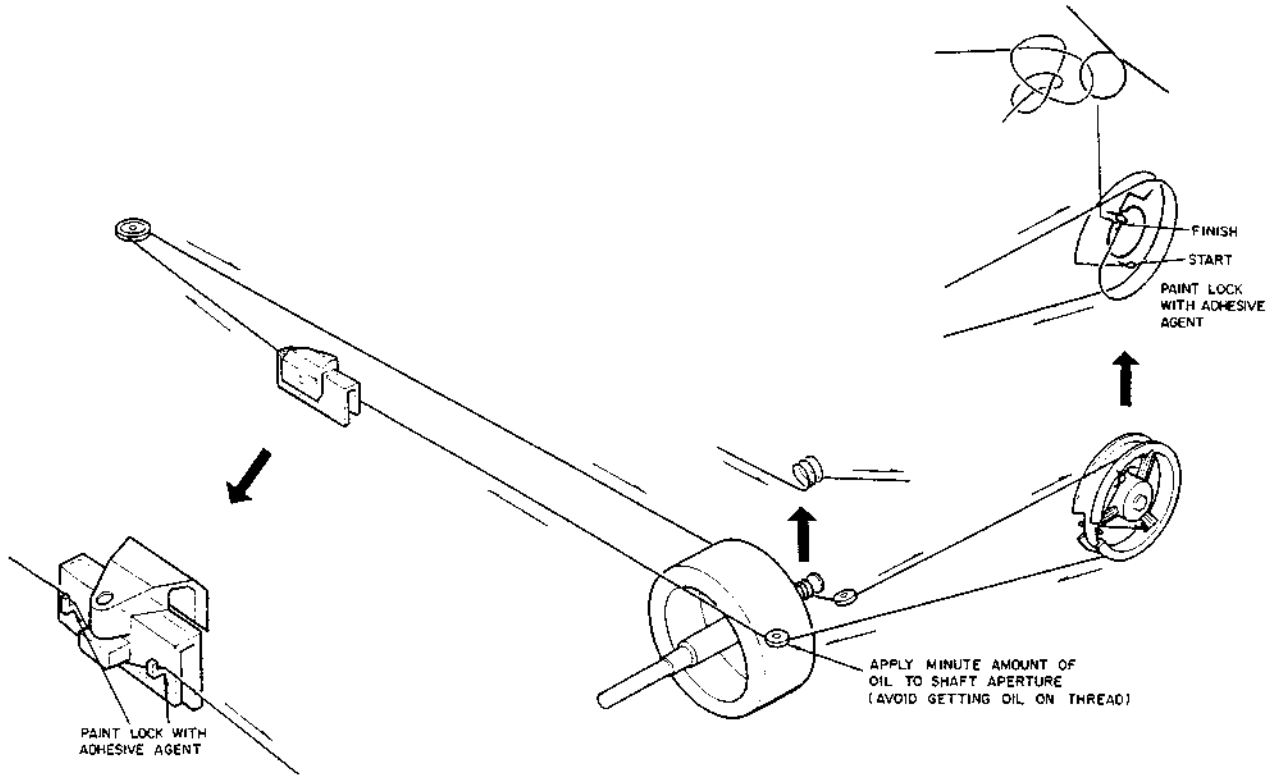

Fig. 8 Tuning Cord Threading

## VIII. CLASSIFICATION OF VARIOUS P.C BOARDS

### 1. P.C BOARD TITLES AND IDENTIFICATION NUMBERS

P.C Board Title	Number of P.C Board
Tuner P.C Board	ATK-2001A
LED P.C Board	ATK-2002
ATT P.C Board	ATK-2003

Chart-3

## 2. COMPOSITION OF VARIOUS P.C BOARDS

Tuner P.C Board ATK-2001A, LED P.C Board ATK-2002 and ATT P.C Board ATK-2003

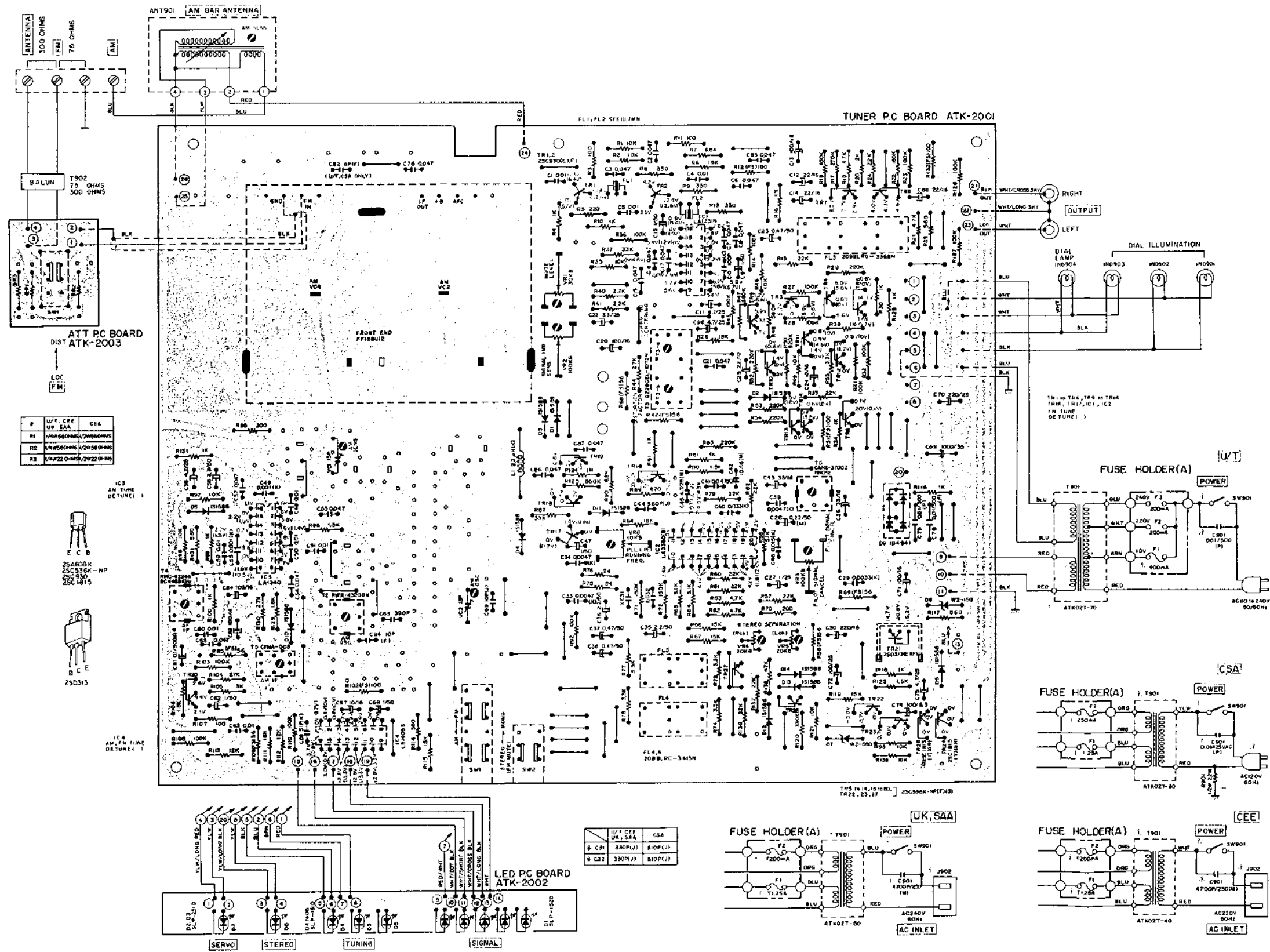

WARNING: INDICATE SAFETY CRITICAL COMPONENTS FOR CONTINUED SAFETY.  
 REPLACE SAFETY CRITICAL COMPONENTS ONLY WITH MANUFACTURER'S  
 RECOMMENDED PARTS.  
 AVERTISSEMENT: INDICER LES COMPOSANTS CRITIQUES DE SÛRETÉ. POUR  
 MAINTENIR LE DEGRÉ DE SÛRETÉ DE L'APPAREIL, NE REMPLACER LES  
 COMPOSANTS DONT LE FONCTIONNEMENT EST CRITIQUE POUR LA SÛRETÉ  
 QUE PAR LES PIÈCES RECOMMANDÉES PAR LE FABRICANT.



---

SECTION 2

**MODEL AM-U02  
SERVICE MANUAL**

TABLE OF CONTENTS

I. TECHNICAL DATA .....	16
II. DISMANTLING OF UNIT .....	17
III. CONTROLS .....	18
IV. PRINCIPAL PARTS LOCATION .....	19
V. VOLTAGE CONVERSION .....	20
VI. LEVEL DIAGRAM .....	21
VII. AMPLIFIER ADJUSTMENT .....	22
VIII. CLASSIFICATION OF VARIOUS P.C BOARDS .....	23
1. P.C BOARD TITLES AND IDENTIFICATION NUMBERS .....	23
2. COMPOSITION OF VARIOUS P.C BOARDS .....	24

For basic adjustments, measuring methods, and operating principles, refer to GENERAL TECHNICAL MANUAL.

## I . TECHNICAL DATA

### POWER AMPLIFIER SECTION

RATED OUTPUT POWER 2-CHANNELS DRIVEN		26 watts per channel, minimum RMS, at 8 ohms from 20 to 20,000 Hz with no more than 0.01% total harmonic distortion.
POWER BANDWIDTH (IHF)		6 Hz to 60 kHz/8 ohms (Total harmonic distortion: 0.1%)
SIGNAL TO NOISE RATIO (IHF)	PHONO	Better than 75 dB
	AUX	Better than 95 dB
RESIDUAL NOISE		Less than 0.5 mV at 8 ohms
CHANNEL SEPARATION (IHF)	PHONO	Better than 55 dB at 1,000 Hz
DAMPING FACTOR		More than 45 (1 kHz, 8 ohms)
OUTPUT	SPEAKERS	A, B (4 to 16 ohms)/A+B (8 to 16 ohms)
	HEADPHONE	4 to 16 ohms

### PRE AMPLIFIER SECTION

INPUT SENSITIVITY/IMPEDANCE	PHONO	3 mV/47 kohms
	AUX	150 mV/100 kohms
	TUNER	150 mV/100 kohms
	TAPE MONITOR	PIN: 150 mV/100 kohms DIN: 150 mV/100 kohms
OUTPUT LEVEL/IMPEDANCE	TAPE REC	PIN: 150 mV/1 kohm DIN: 30 mV/30 kohms
	PRE OUTPUT	1 V/1 kohm
FREQUENCY RESPONSE	PHONO (RIAA EQUALIZATION)	30 Hz to 15 kHz +0.5 dB, -0.5 dB
	TUNER, AUX, TAPE MONITOR	10 Hz to 40 kHz +0 dB, -2 dB
TONE CONTROL	BASS	±8.5 dB at 100 Hz
	TREBLE	±8.5 dB at 10 kHz
	LOUDNESS CONTROL	1: +3 dB at 100 Hz, +2.5 dB at 10 kHz 2: +6.5 dB at 100 Hz, +5.0 dB at 10 kHz 3: +10 dB at 100 Hz, +9.5 dB at 10 kHz (Volume control set at -30 dB position)
FILTER	HIGH	-3 dB at 10 kHz
	SUBSONIC	-3 dB at 18 Hz

### MISCELLANEOUS

SEMICONDUCTORS	Transistors: 16. Diodes: 19, ICs: 9
POWER REQUIREMENTS	120 V, 60 Hz for U.S.A. and Canada 220 V, 50 Hz for Europe except UK and Australia 240 V, 50 Hz for UK and Australia 110/220/240 V, 50/60 Hz Switchable for other countries
POWER CONSUMPTION	140 W
DIMENSIONS	440 (W) x 105 (H) x 300 (D) mm (17.3" x 4.1" x 11.8")
WEIGHT	7.8 kg (17.2 lbs)

\* For improvement purposes, specifications and design are subject to change without notice.



## II. DISMANTLING OF UNIT

In case of trouble, etc. necessitating dismantling, please dismantle in the order shown in the photographs. Reassemble in reverse order.

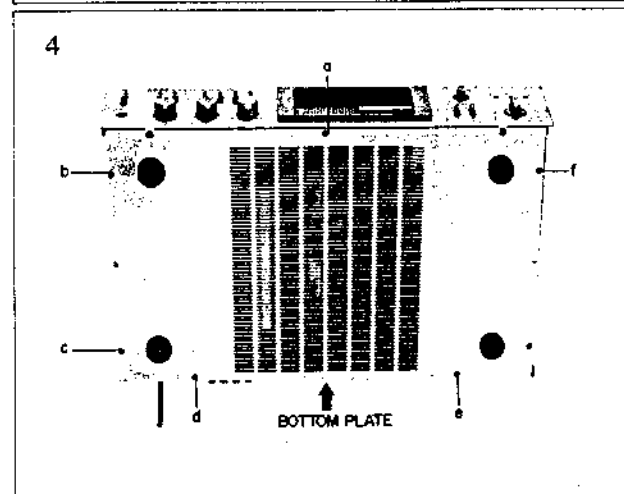
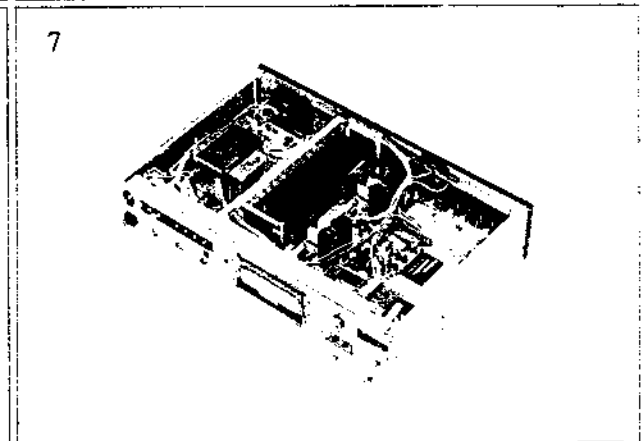
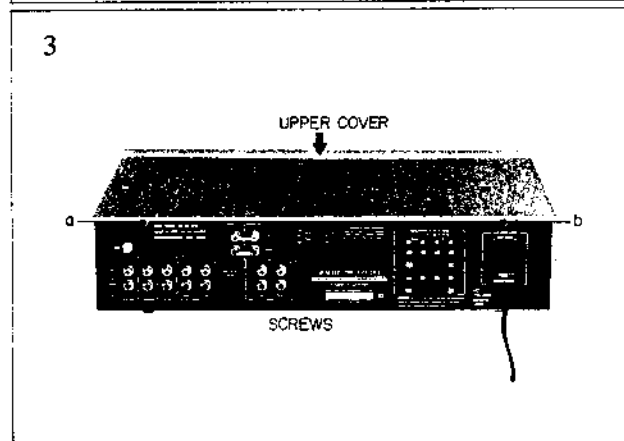
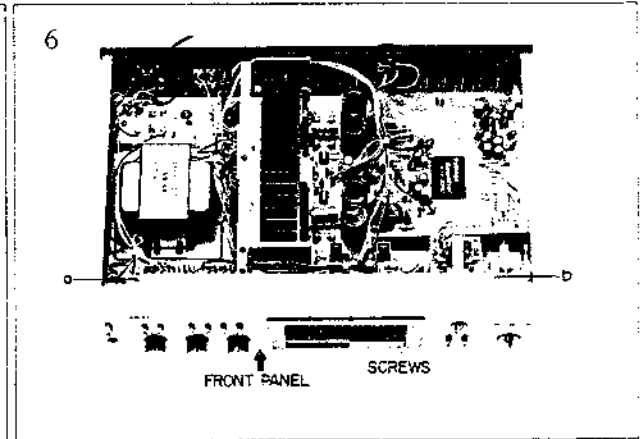
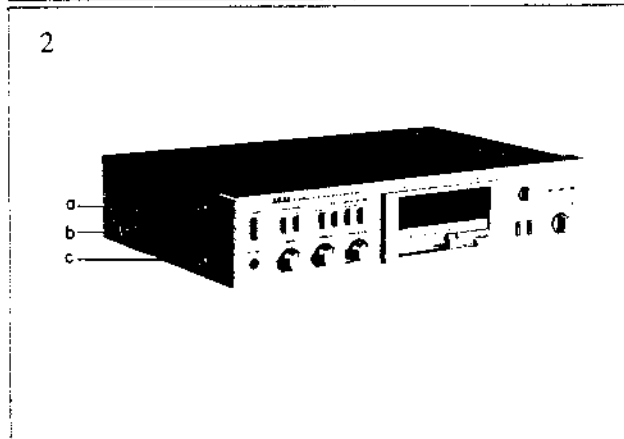
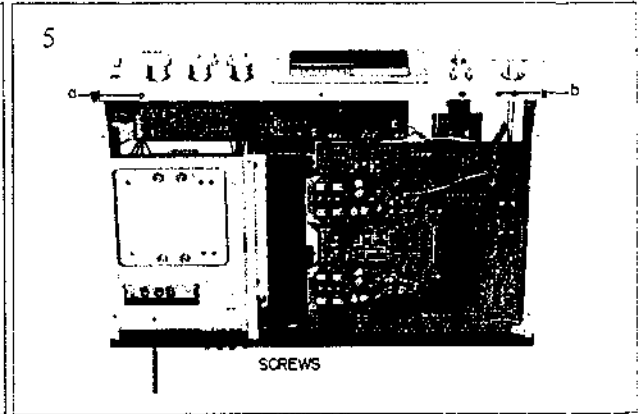
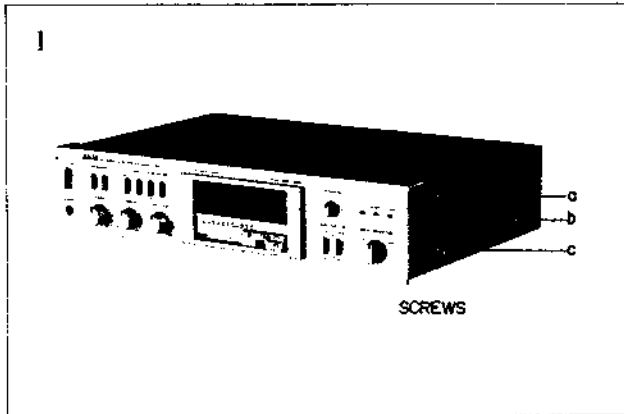

### III. CONTROLS

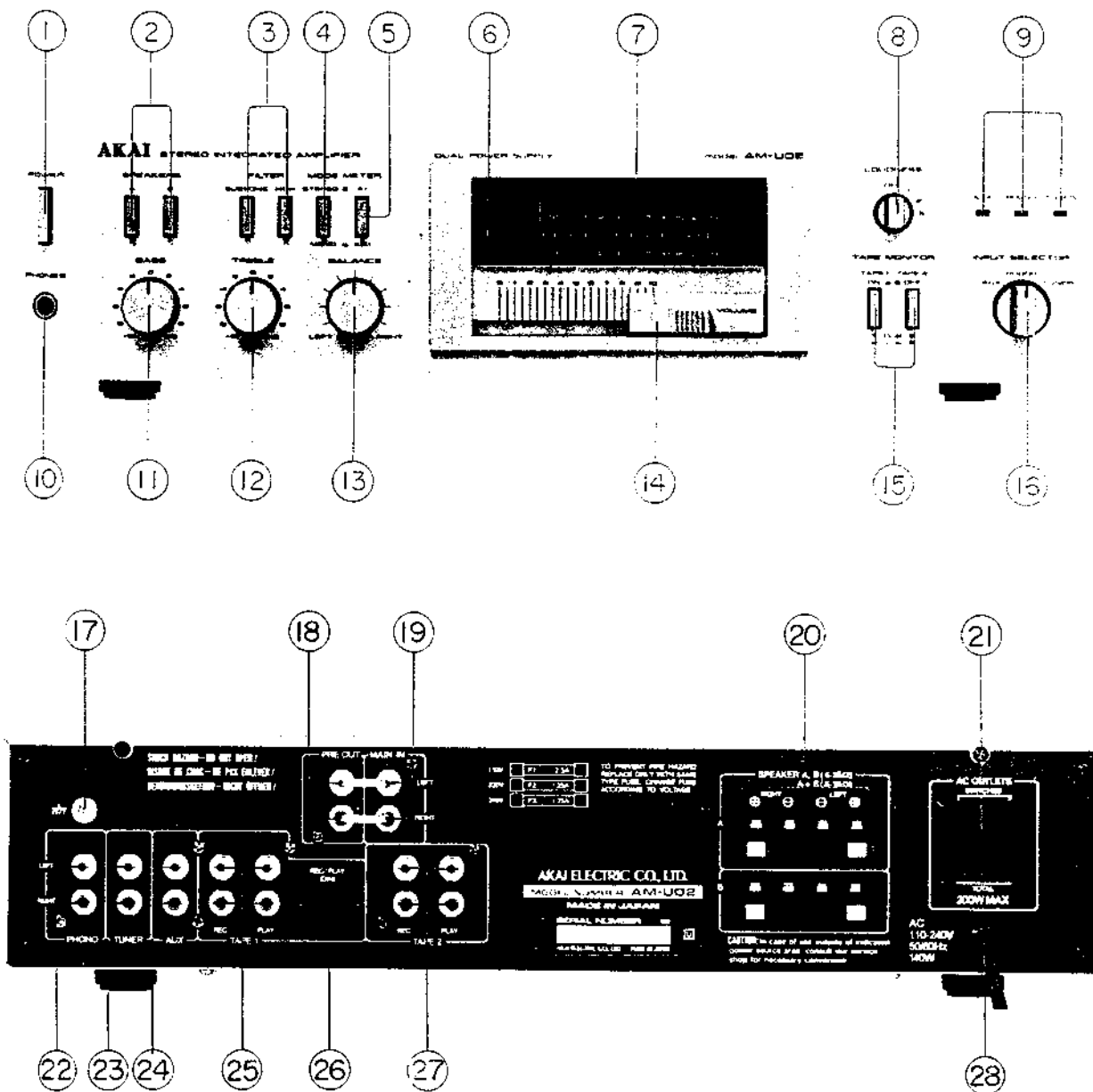

Fig. 1 Controls

- |                                     |  |
|-------------------------------------|--|
| 1. POWER SWITCH                     | 16. INPUT SELECTOR   |
| 2. SPEAKER SYSTEM SELECTOR SWITCHES | 17. GROUND TERMINAL  |
| 3. FILTER SWITCHES                  | 18. PRE-OUT TERMINALS  |
| 4. MODE SELECTOR                    | 19. MAIN-IN TERMINALS  |
| 5. METER SWITCH                     | 20. A AND B SYSTEM SPEAKER TERMINALS   |
| 6. CLIPPING INDICATOR               | 21. EXTRA AC OUTLETS (Some models are not equipped with this facility.)  |
| 7. FLD BAR METER                    | 22. PHONO TERMINALS  |
| 8. LOUDNESS SWITCH                  | 23. TUNER TERMINALS  |
| 9. INPUT SELECTOR INDICATOR         | 24. AUX TERMINALS  |
| 10. HEADPHONE JACK                  | 25. TAPE 1 SYSTEM REC/PLAY TERMINALS   |
| 11. BASS CONTROL                    | 26. TAPE 1 SYSTEM DIN JACK   |
| 12. TREBLE CONTROL                  | 27. TAPE 2 SYSTEM REC/PLAY TERMINALS   |
| 13. STEREO BALANCE CONTROL          | 28. AC CORD (Some models are equipped with an AC Inlet instead of an AC cord. Connect with an appropriate power cord.) |
| 14. VOLUME CONTROL                  |  |
| 15. TAPE MONITOR SWITCHES           |  |

# IV. PRINCIPAL PARTS LOCATION

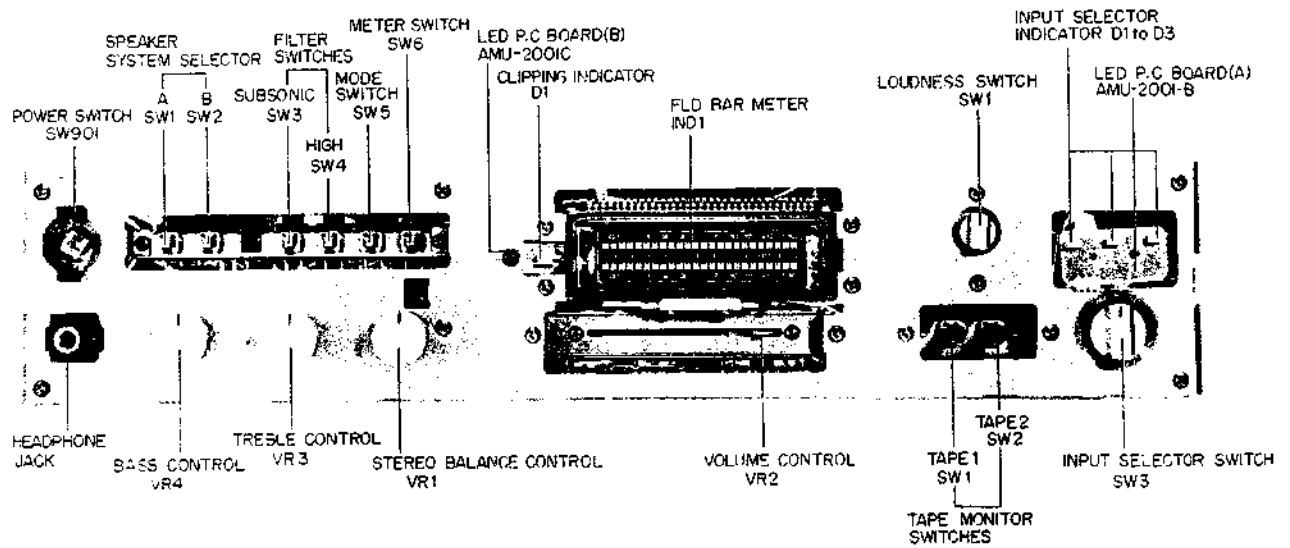

Fig. 2 Front View

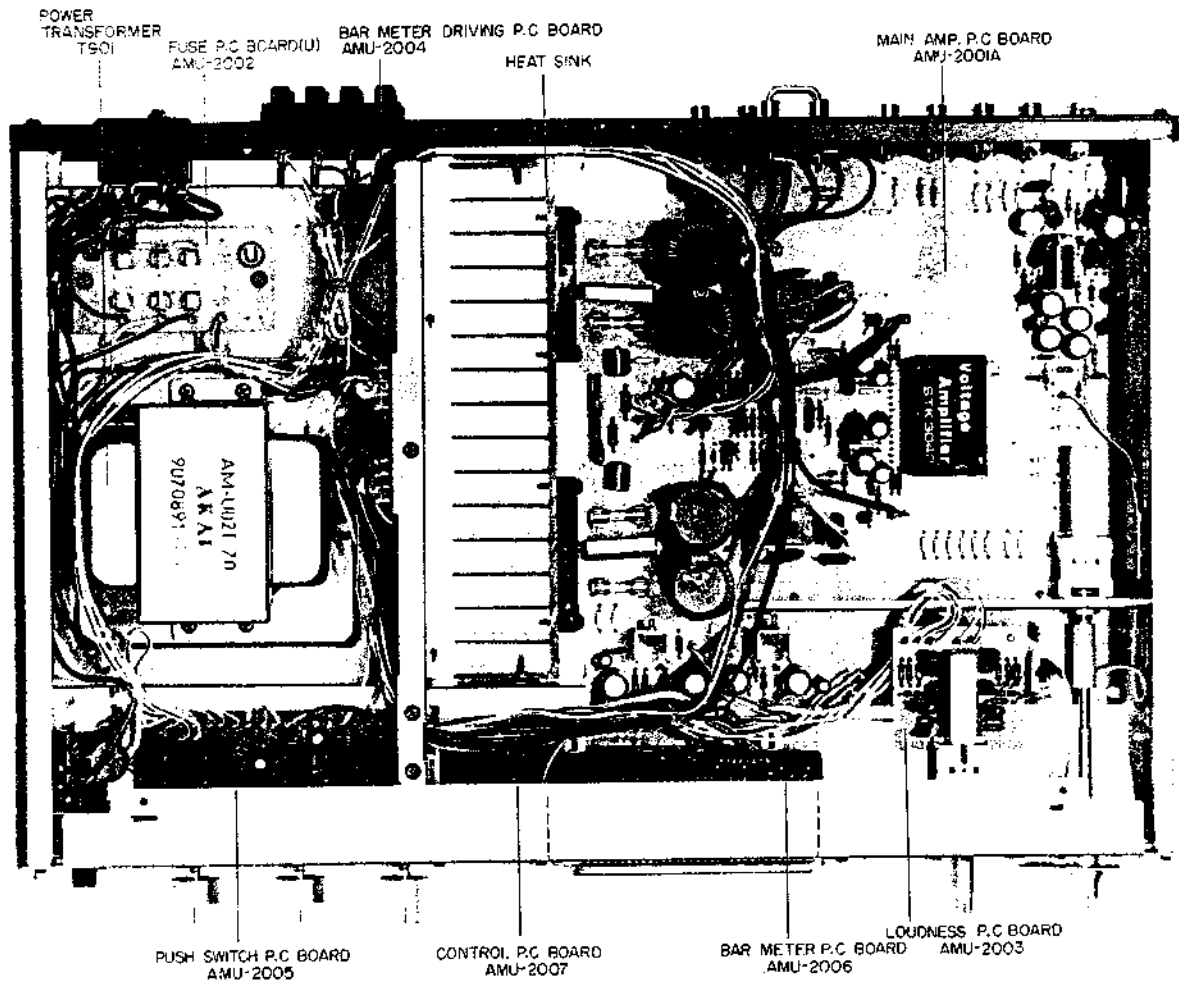

Fig. 3 Top View

## V. VOLTAGE CONVERSION

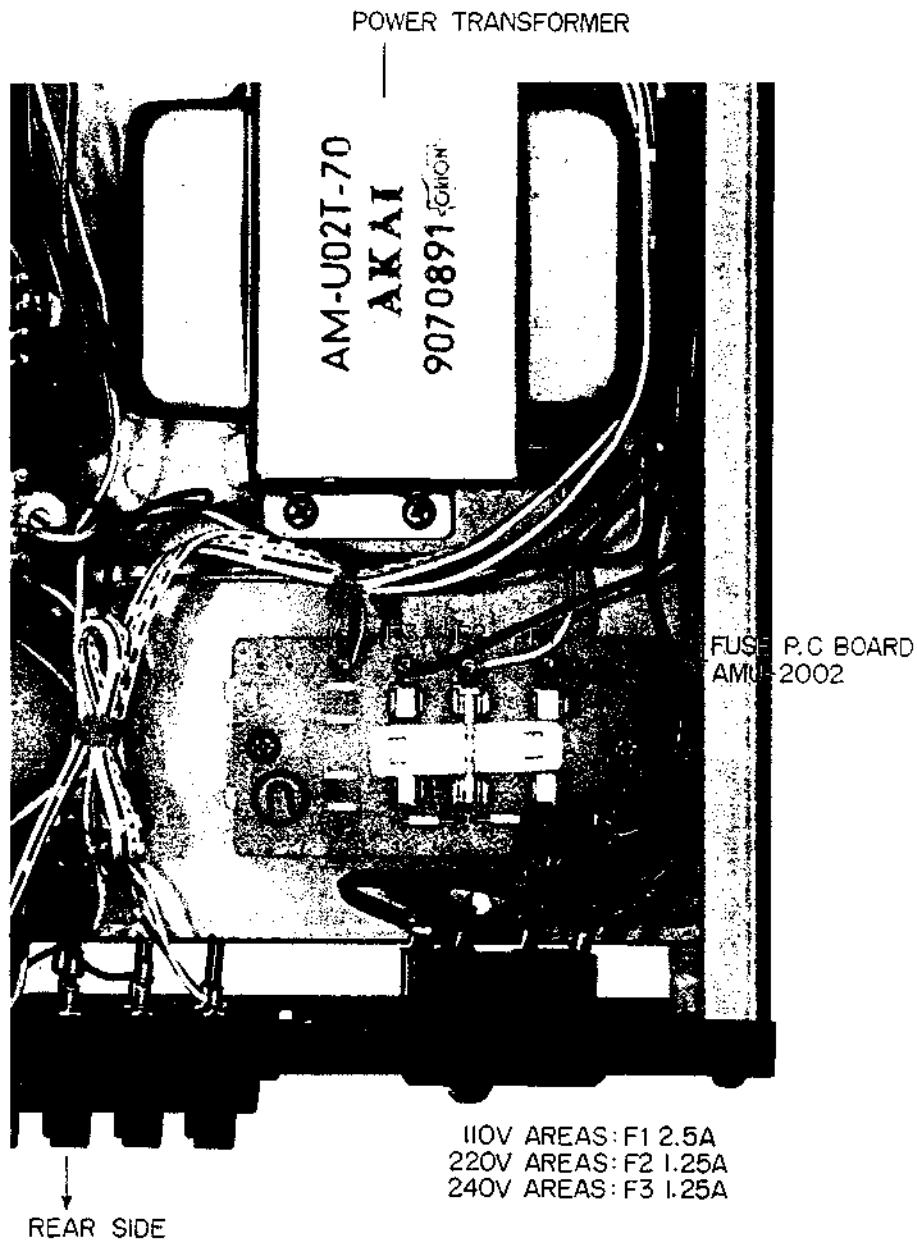

Fig. 4 Voltage Conversion (U/T Model)

Models for Canada, USA, Europe, UK, JPN and Australia are not equipped with this facility.

Each machine is preset at the factory according to destination but some machines can be set to 110 V, 220 V or 240 V as required.

If voltage change is necessary, this can be accomplished as follows.

- 1) Disconnect AC Power Cord.
- 2) Loosen holding screws and remove upper cover.
- 3) Remove existing line voltage fuse and insert required line voltage fuse in proper fuse holder, explicitly following instructions printed on rear panel.

# VI. LEVEL DIAGRAM

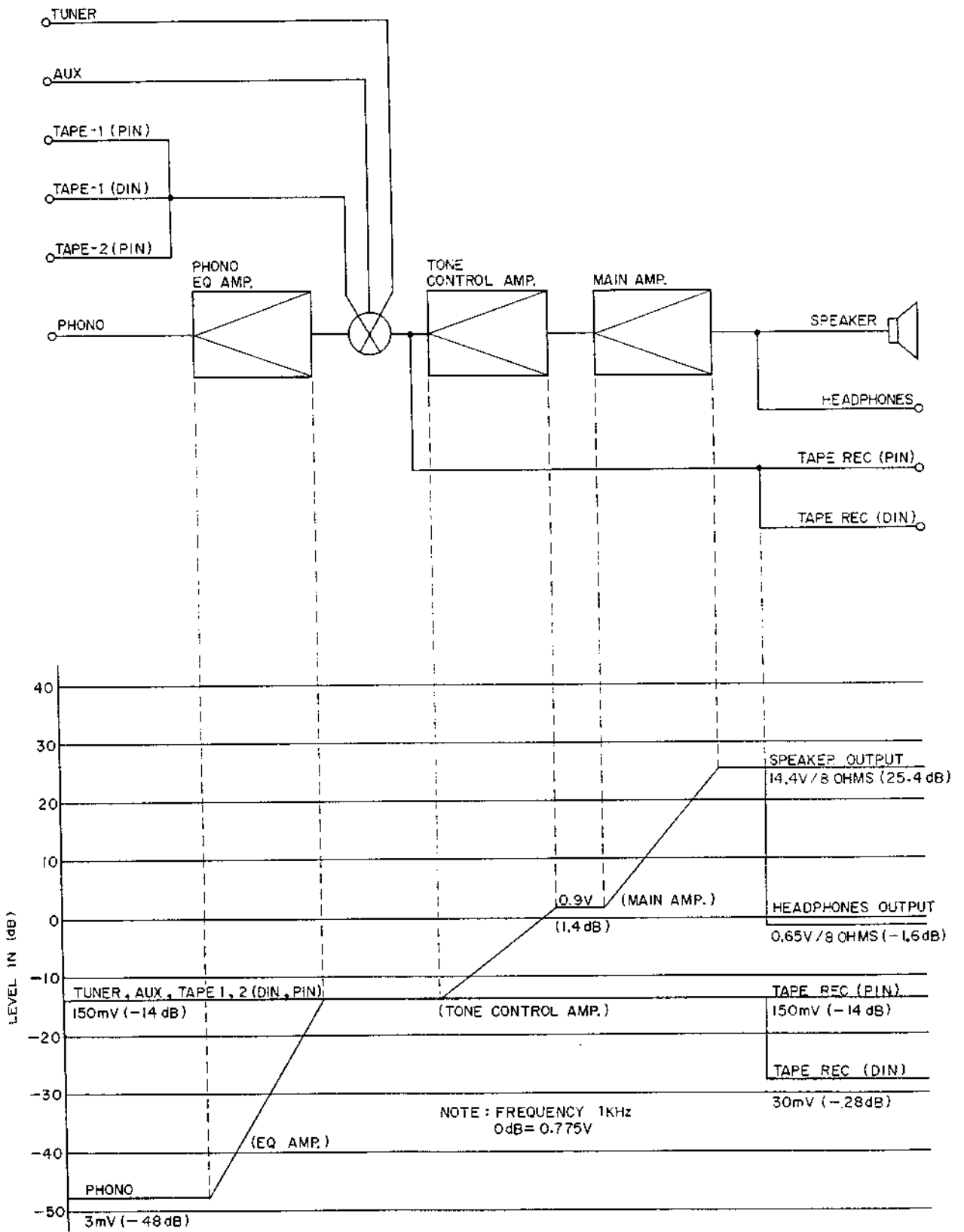

Fig. 5 Level Diagram

## VII. AMPLIFIER ADJUSTMENT

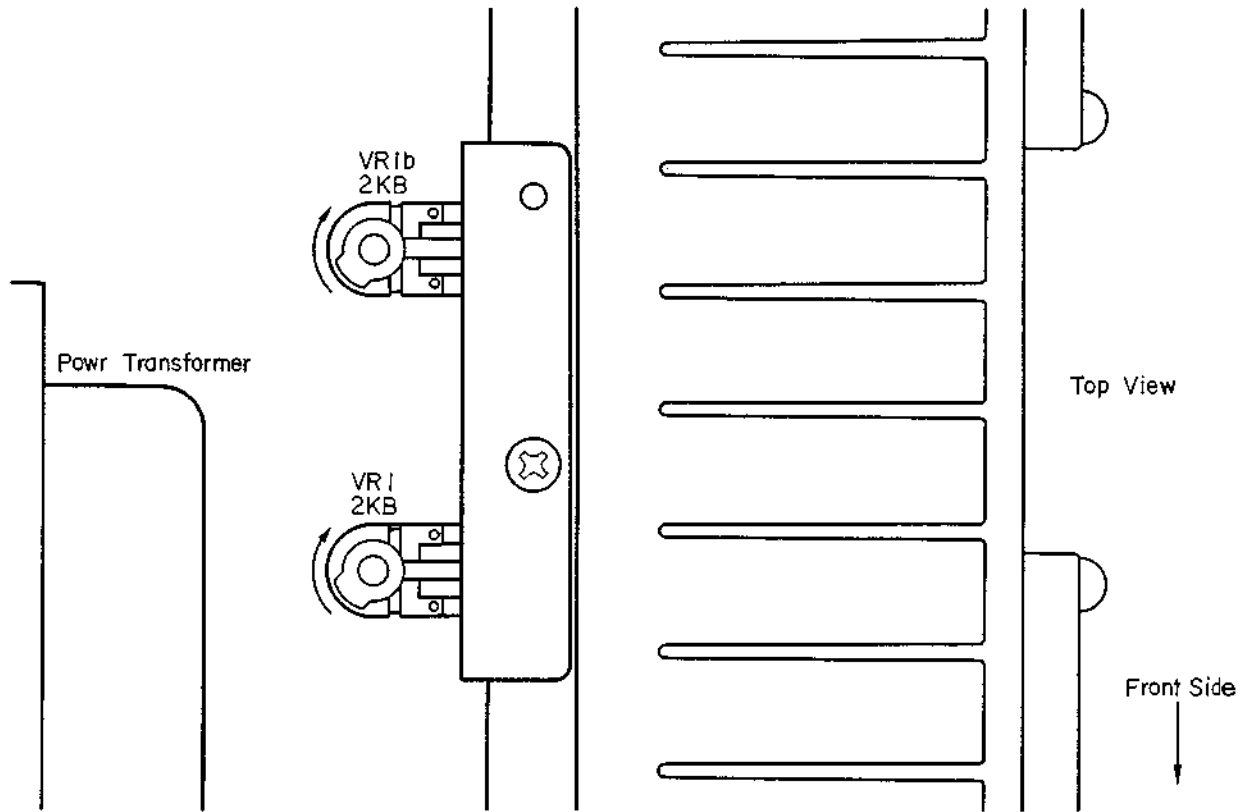

Fig. 6 Bar Meter Driving P.C Board AMU-2004

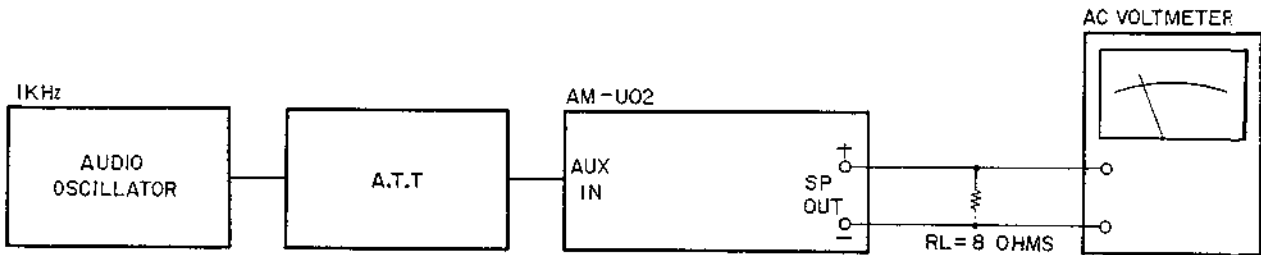

Fig. 7 Instrument Connections

### METER SENSITIVITY ADJUSTMENT

(Refer to Figs. 6, 7)

The Meter range switch should be set to "x1".

Feeding in 1 kHz from audio oscillator, adjustment the VOLUME knob so as to make the voltage at both ends of the RL (8 ohms) 8.9 V.

Also, adjust VR 1 (2 kB, L-ch) and VR 2 (2 kB, R-ch) to the point where the 10 watts indicator will start lighting up.

## VIII. CLASSIFICATION OF VARIOUS P.C BOARDS

### I. P.C BOARD TITLES AND IDENTIFICATION NUMBERS

P.C Board Title	P.C Board Number
Main Amp. P.C Board	AMU-2001A
LED P.C Board (A)	AMU-2001B
LED P.C Board (B)	AMU-2001C
Fuse P.C Board	AMU-2002
Loudness P.C Board	AMU-2003
Bar Meter Driving P.C Board	AMU-2004
Push Switch P.C Board	AMU-2005
Bar Meter P.C Board	AMU-2006
Control P.C Board	AMU-2007

Chart-1

## 2. COMPOSITION OF VARIOUS P.C BOARDS

### 1) Main Amp. P.C Board AMU-2001A (3ED) and LED P.C Board (A)/(B) AMU-2001B/C

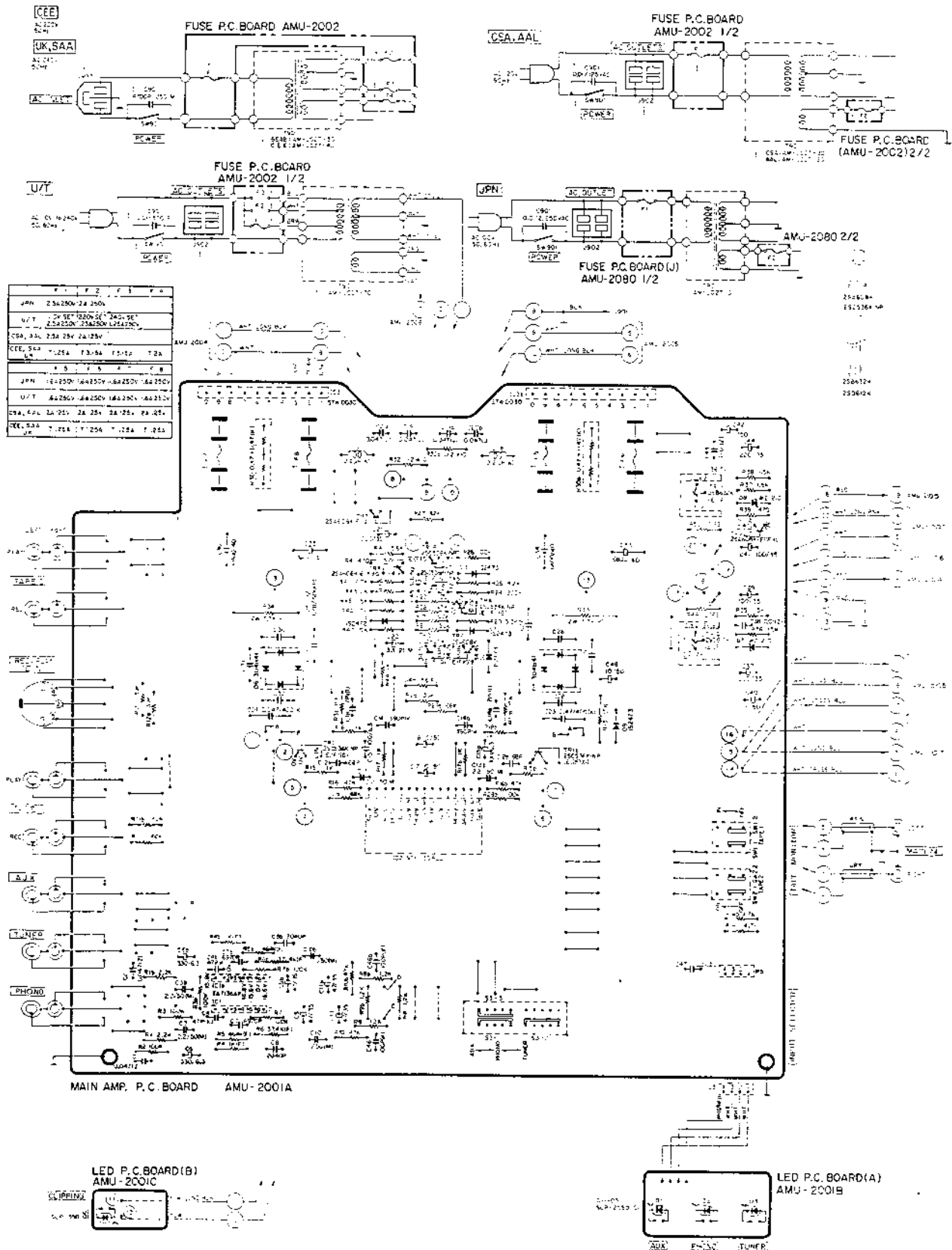

WARNING: INDICATES SAFETY CRITICAL COMPONENTS FOR CONTINUED SAFETY. REPLACE SAFETY CRITICAL COMPONENTS ONLY WITH MANUFACTURER'S RECOMMENDED PARTS.  
 AVERTISSEMENT: INDICATE LES COMPOSANTS CRITIQUES DE SURETE POUR MAINTENIR LE NIVEAU DE SURETE RECOMMANDE PAR LE FABRICANT. NE REMPLACEZ QUE LES COMPOSANTS CRITIQUES DE SURETE RECOMMANDES PAR LE FABRICANT.



2) Bar Meter Driving P.C Board AMU-2004

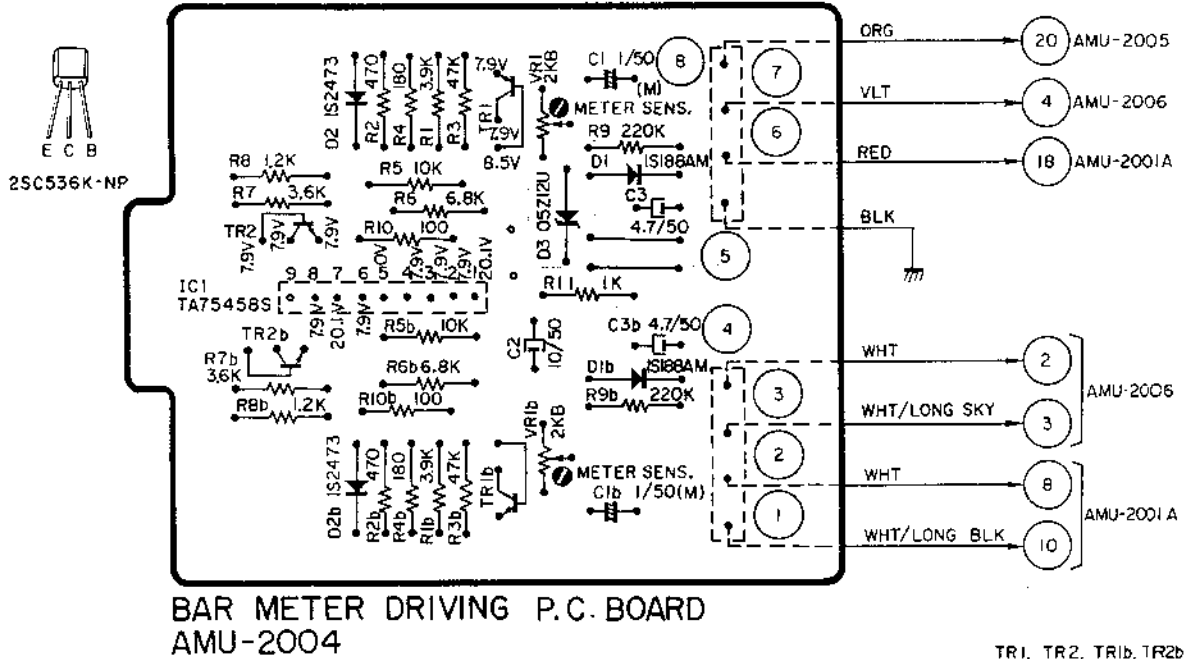

3) Bar Meter P.C Board AMU-2006

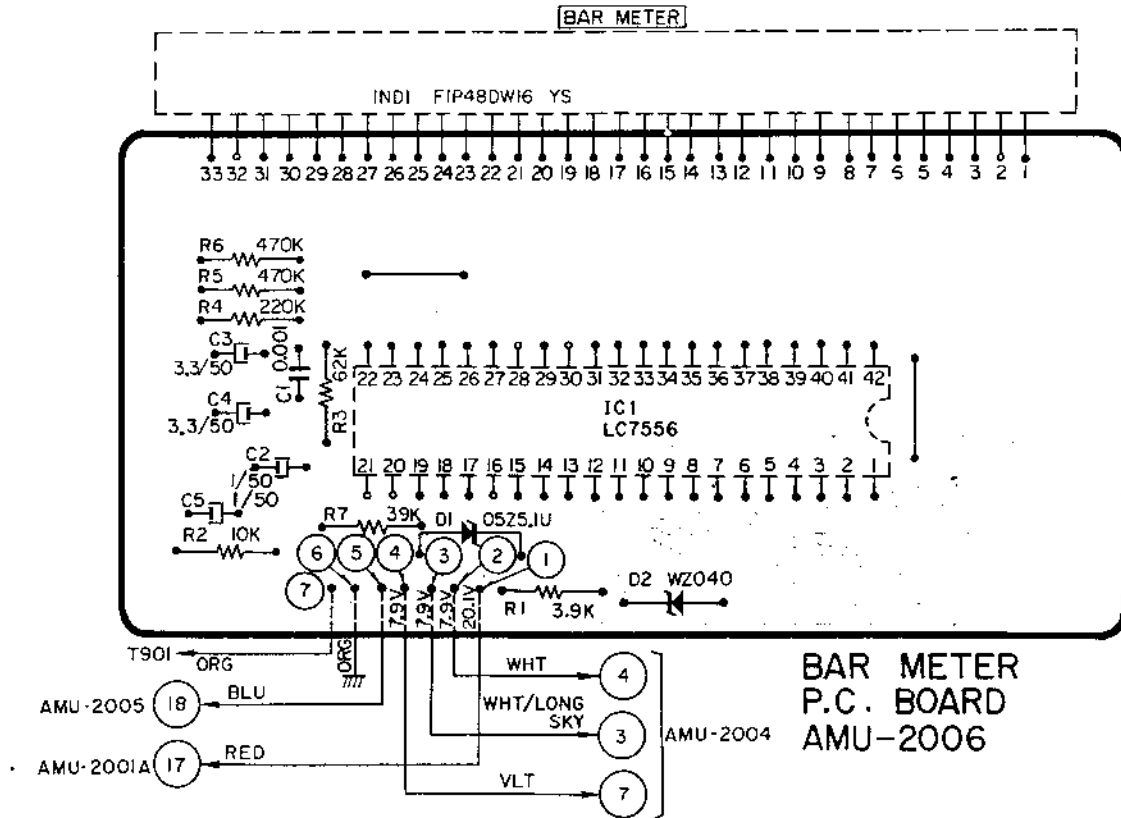

4) Push Switch P.C Board AMU-2005

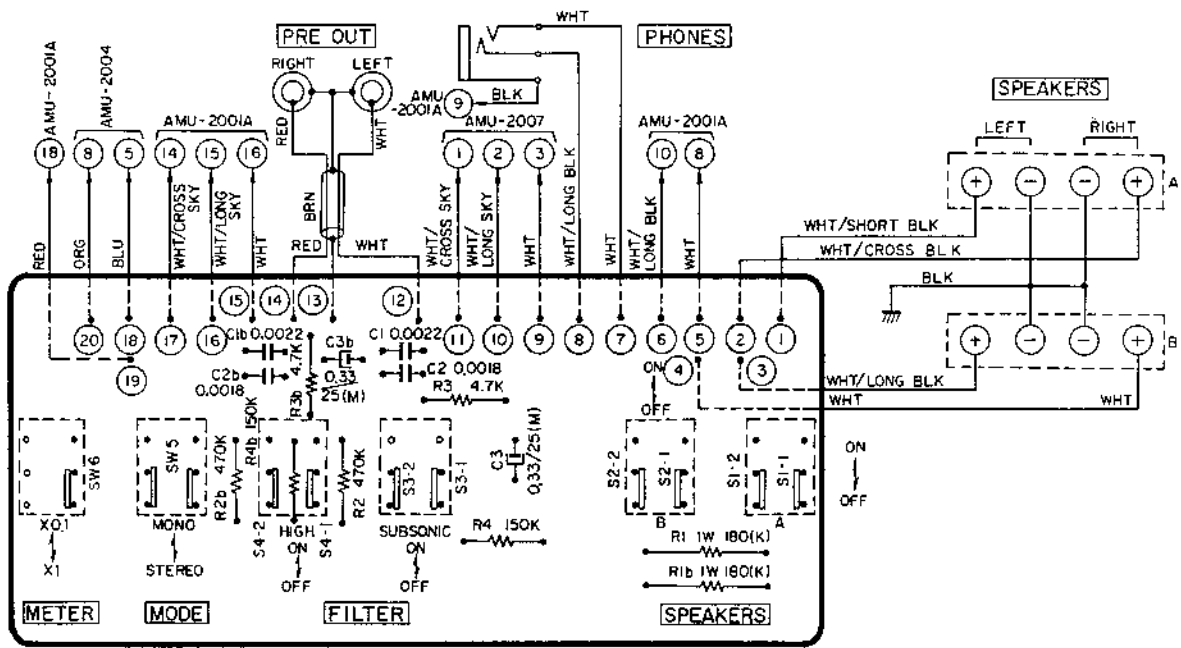

PUSH SWITCH P.C BOARD  
AMU-2005

5) Loudness P.C Board AMU-2003 and Control P.C Board AMU-2007

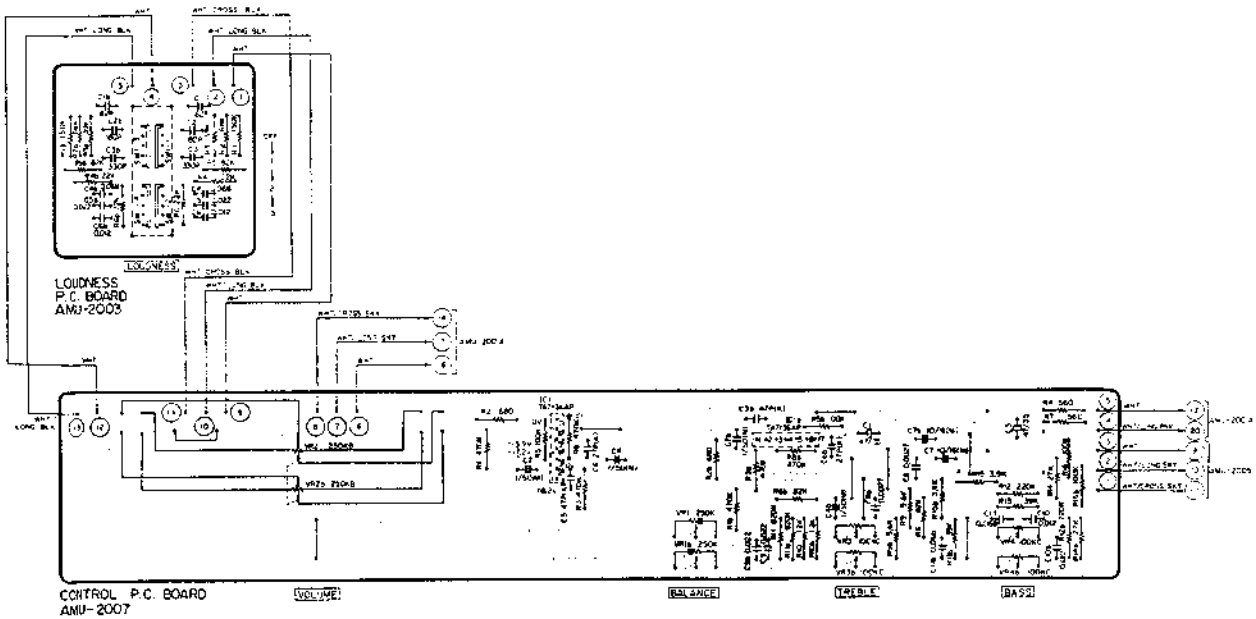

---

SECTION 3

**PARTS LIST**

TABLE OF CONTENTS

<b>I. AT-K02</b>	
1. RECOMMENDED SPARE PARTS LIST .....	34
2. TUNER P.C BOARD (ATK-2001A) BLOCK .....	36
3. FINAL ASSEMBLY BLOCK .....	37
<b>II. AM-U02</b>	
1. RECOMMENDED SPARE PARTS LIST .....	38
2. MAIN AMP P.C BOARD (AMU-2001A) BLOCK .....	40
3. CONTROL P.C BOARD (AMU-2007) BLOCK .....	40
4. BAR METER P.C BOARD (AMU-2006) BLOCK .....	41
5. BAR METER DRIVE P.C BOARD (AMU-2004) BLOCK .....	41
6. LOUDNESS P.C BOARD (AMU-2003) BLOCK .....	41
7. PUSH SW. P.C BOARD (AMU-2005) BLOCK .....	41
8. FINAL ASSEMBLY BLOCK .....	42
<b>INDEX</b> .....	<b>44</b>

Resistor and Capacitor which is not listed in this parts list, please refer to COMMON LIST FOR SERVICE PARTS.

## HOW TO USE THIS PARTS LIST

1. This parts list is compiled by various individual blocks based on assembly process.
2. When ordering parts, please describe parts number, serial number, and model number in detail.
3. How to read list.

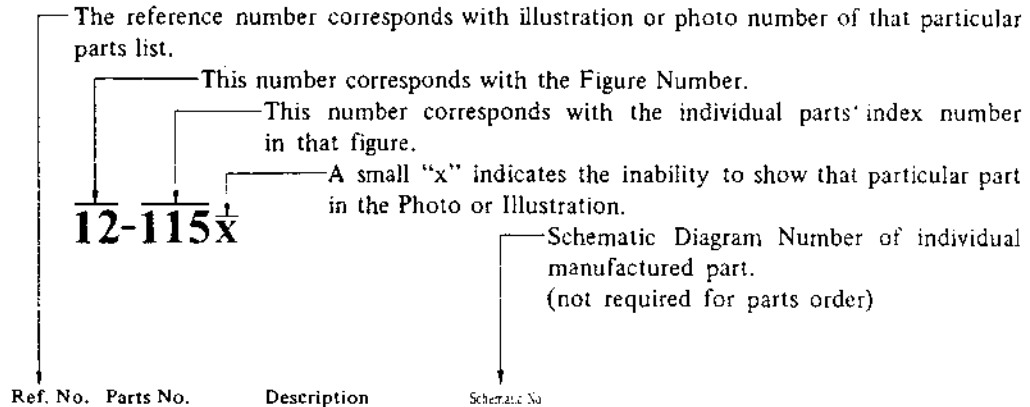

Ref. No.	Parts No.	Description	Schematic No.
<b>FLYWHEEL BLOCK #13</b>			
12-115x	800425	Flywheel Block Assy. Comp.	RD-13
12-116	244506	Flywheel Only	RD-13
12-117x	244754	Felt, Flywheel	RD-13
12-118	251324	Main Metal Case	RD-13
12-119	253080	Main Metal	RD-13

4. The symbol numbers shown on the P.C. Board list can be matched with the Composite Views of components of the Schematic Diagram or Service Manual.
5. The indications of Resistors and Capacitors in the photos of P.C. Board are being eliminated.
6. The shape of the parts and parts name, etc. can be confirmed by comparing them with the parts shown on the Electrical Parts Table of P.C. Board.
7. Both the kind of part and installation position can be determined by the Parts Number. To determine where a parts number is listed, utilize Parts Index at end of Parts List.  
It is necessary first of all to find the Parts Number. This can be accomplished by using the Reference Number listed at right of parts number in the Parts Index. (meaning of ref. no. outlined in Item 3 above).
8. Utilize separate "Price List for Parts" to determine unit price. The most simple method of finding parts Price is to utilize the reference number.

### CAUTION:

1. When placing an order for parts, be sure to list the parts no. model no., and description. There are instances in which if any of this information is omitted, parts cannot be shipped or the wrong parts will be delivered.
2. Please be careful not to make a mistake in the parts no. If the parts no. is in error, a part different from the one ordered may be delivered.
3. Because parts number and parts unit supply in the Preliminary Service Manual (Basic Parts List) may be partially changed, please use this parts list for all future reference.

**WARNING:** Δ INDICATES SAFETY CRITICAL COMPONENTS. FOR CONTINUED SAFETY, REPLACE SAFETY CRITICAL COMPONENTS ONLY WITH MANUFACTURER'S RECOMMENDED PARTS.

**AVERTISSEMENT:** Δ IL INDIQUE LES COMPOSANTS CRITIQUES DE SURETE. POUR MAINTENIR LE DEGRE DE SECURITE DE L'APPAREIL NE REMPLACER LES COMPOSANTS DONT LE FONCTIONNEMENT EST CRITIQUE POUR LA SECURITE QUE PAR DES PIECES RECOMMANDEES PAR LE FABRICANT.

## AC INLET SYSTEM

This model is equipped with an AC INLET SYSTEM. Please refer to the AC INLET SYSTEM CHART below for the specific type. By the AC INLET SYSTEM, AC (mains) cord can be connected to and disconnected from the model because the model is provided with socket exclusively for AC (mains) cord on its main body. Please note, however, that certain models are not equipped with this system and has a built-in AC (mains) cord as before.

### AC INLET SYSTEM CHART

#### CLASS I

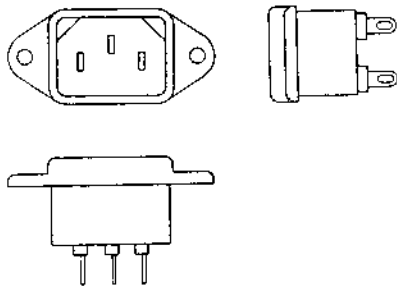

Picture 1  
AC INLET  
to be  
installed  
on machines

#### CLASS II

Ⓜ This mark indicating double insulation will be attached to machine's rear panel

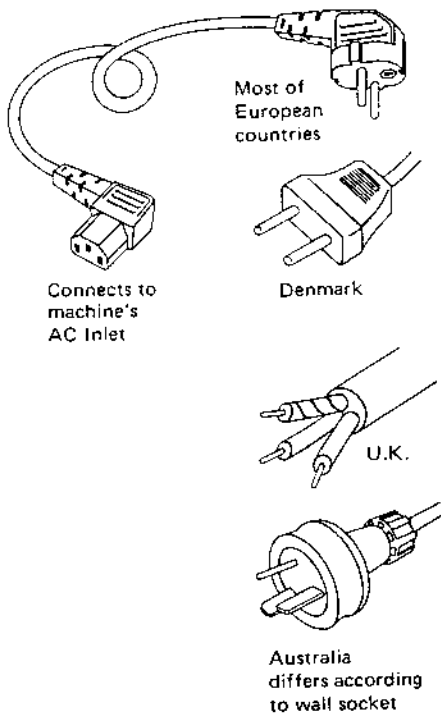
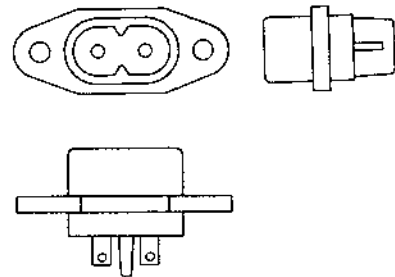

Picture 2  
AC (mains)  
cord

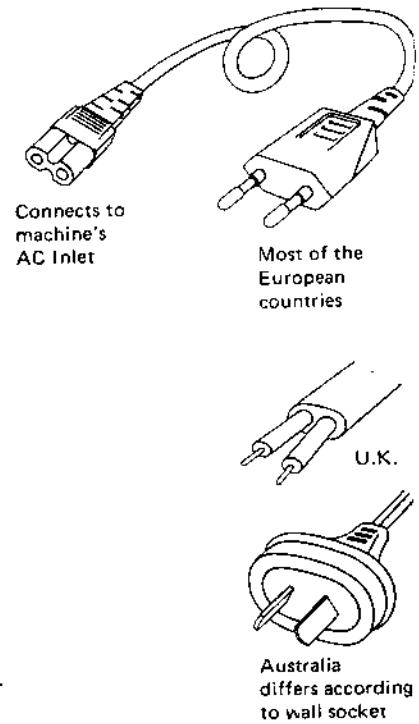

#### Parts List for AC (mains) Cord Set

Standard		Description	Type of AC Inlet	Parts No.
Class I	CEE	Cord Set CEE (3 cores)	3P	EW30293
	BEAB	Cord Set BEAB (3 cores)	3P	EW30294
	SAA	Cord Set SAA (3 cores)	3P	EW30296
	U/T	Cord Set U/T (3 cores)	3P	EW30246
Class II	CEE	Cord Set CEE (2 cores)	2P	EW63844
	BEAB	Cord Set BEAB (2 cores)	2P	EW30295
	SAA	Cord Set SAA (2 cores)	2P	EW30291
	U/T	Cord Set U/T (2 cores)	2P	EW30299

# I. MODEL AT-K02

## I. RECOMMENDED SPARE PARTS LIST

Because, if the parts listed below are on hand, almost any repair can be accomplished, we suggest that you stock these Recommended Spare Parts Items.

Parts No.	Description	Notes
BA320245	Tuner PCB Comp. AT-K02 (CEE)	(CEE, UK, SAA)
BA320244	Tuner PCB Comp. AT-K02 (CSA)	(CSA, AAL)
BA320243	Tuner PCB Comp. AT-K02 (U/T)	
BT322217	△ Power Trans. AT-K02T-30	(CSA, AAL)
BT322206	△ Power Trans. AT-K02T-40	(CEE)
BT322218	△ Power Trans. AT-K02T-50	(UK, SAA)
BT322177	△ Power Trans. AT-K02T-70	(U/T)
BT307204	AM-IF Trans. CFMA-008	
BT293398	AM-IF Trans. RMC-42246BCH 468 kHz	
EC204671	△ Ceramic/C. DD31-6E 0.01μF (P) 500WV	(U/T)
EC314688	△ Ceramic/C. DE7150 FZ 0.01μF (P) 125WV	(CSA, AAL)
EC301320	△ MP/C. 4700PF (M) 250WV	(CEE, UK, SAA)
EC616342	Trimmer/C. CTY122D33 15PF	
ED322247	LED SLP-151D	
ED322184	LED SLP-152D	
ED322215	LED SLP-251D	
ED557447	Silicon Diode 1S1588	
ED322238	Silicon Stack 1B4B41	
ED315367	Zener Diode WZ-050	
ED237960	Zener Diode WZ-150	
EE322245	Bar Ant	
EE322242	Front End FFJ26U12	
EF309392	△ Fuse 1.25A 125V	(CSA, AAL)
EF315334	△ Fuse 250mA 125V	(CSA, AAL)
EF309389	△ Fuse 400mA 250V	(U/T)
EF300588	△ Fuse (EAWK)	(CEE, UK, SAA)
EF602550	△ Fuse (SEMKO T Type) 1.25AT 250V	(CEE, UK, SAA)
EI293185	IC LA-1240	
EI315491	IC LB1405S	
EI322248	IC LA1231N	
EI322185	IC LA3380 (B)	
EJ301513	△ Inlet 2P	(CEE, UK, SAA)
EL322236	Lamp (Cord Type) 8V 300mA (400mmx2)	
EL322234	Lamp (Cord Type) 8V 50mA (350mmx2)	
EO322239	DET Coil Q228CEL-1072N	
EO322241	MPX Coil CANS-3700Z	
EO307186	OSC Coil RWR-43208N	
EO539820	Peaking Coil 2.2μH (K)	
ER307201	Ceramic Filter SFE10.7mm	
ER322181	Low Pass Filter 208BLRC-3415N	
ER322237	Low Pass Filter 209BLRG-3368N	

Parts No.	Description	Notes
ES310839	△ Push SW. SDG1P-E 5A/80A 250V	(U/T, CEE, UK, SAA)
ES665875	△ Push SW. SDG1P-J TV-3 UL/CSA	(CSA, AAL)
ES322243	Push SW. JK2108	
ES324238	Slide SW. SSB02204	
ET322244	Transistor 2SA608K-NP (F) (G)	
ET307234	Transistor 2SC1815 (Y) (GR)	
ET316643	Transistor 2SC536K-NP (F) (G)	
ET618873	Transistor 2SC930 (E) (F)	
EV604438	Semi-Fixed/Vol. V10K8-4-2 B10K	
EV593368	Semi-Fixed/Vol. V10K8-4-2 B30K	
EV550023	Semi-Fixed/Vol. V10K8-4-2 100K (B)	
EV551452	Semi-Fixed/Vol. (Solid Type) SR19R 22K B	
EW306428	△ AC Cord (U/T)	
EW305691	△ AC Cord CUL	(CSA, AAL)
EW302995	△ AC Cord SET BEAB 2 Cores	(UK)
EW315767	△ AC Cord SET CEE 2 Cores	(CEE)
EW322401	△ AC Cord SET SAA 2 Cores	(SAA)

## 2. TUNER P.C BOARD (ATK-2001A) BLOCK

Symbol No.	Parts No.	Description	Schematic No.	Symbol No.	Parts No.	Description	Schematic No.
2-1	BA320243	Tuner PCB Comp. AT-K02 (U/T)	ATK-2001A, B	2-R109	ER324337	Carbon/R. F 1/4WS 56 ohms (J)	35-11-30
2-2	BA320244	Tuner PCB Comp. AT-K02 (CSA) (CSA, AAL)	ATK-2001A, B	2-R132	ER307196	Carbon/R. F 1/4W 100 ohms (J)	35-11-25
2-3	BA320245	Tuner PCB Comp. AT-K02 (CEE) (CEE, UK, SAA)	ATK-2001A, B	2-C31	EC513990	Styrol/C. (Vert.) 330PF (J) 50WV (U/T, CEE, UK, SAA)	24-11-3
2-IC1	EI322248	IC LA1231N	45-8-113	2-C31	EC672287	Styrol/C. (Vert.) 510PF (J) 50WV (CSA, AAL)	24-11-3
2-IC2	EI322185	IC LA3380 (B)	45-8-113	2-C32	EC513990	Styrol/C. (Vert.) 330PF (J) 50WV (U/T, CEE, UK, SAA)	24-11-3
2-IC3	EI293185	IC LA-1240	45-8-220	2-C42	EC313534	NP/C.	
2-IC4	EI315491	IC LB1405S	45-8-365	2-C32	EC672287	Styrol/C. (Vert.) 510PF (J) 50WV (CSA, AAL)	24-17-31
2-TR1,2	ET618873	Transistor 2SC930 (E)(F)	45-1-185	2-C44	EC435690	Styrol/C. (Vert.) 560PF (J) 50WV	24-11-3
2-TR3,4	ET322244	Transistor 2SA608K-NP (F) (G)	45-1-375	2-C45	EC315335	NP/C. 4.7μF (M) 25WV	24-11-3
2-TR5to14	ET316643	Transistor 2SC536K-NP (F) (G)	45-1-362	2-C83	EC514001	Styrol/C. (Vert.) 390PF (J) 50WV	24-17-31
2-TR16to20	ET316643	Transistor 2SC536K-NP (F) (G)	45-1-362	2-4	EE322242	Front End FF126U12	24-11-3
2-TR21	ET452534	Transistor 2SD313(E)(F)	45-1-105	2-5	ZS325495	Tapping Screw, #2 BR 3x6	57-2-53
2-TR22,23	ET316643	Transistor 2SC536K-NP (F) (G)	45-1-362				
2-TR24,25	ET307234	Transistor 2SC1815 (Y) (GR)	45-1-299				
2-TR27	ET316643	Transistor 2SC536K-NP (F) (G)	45-1-362				
2-TR28	ET322244	Transistor 2SA608K-NP (F) (G)	45-1-375				
2-D1to6	ED557447	Silicon Diode 1S1588	45-3-22				
2-D7	ED315367	Zener Diode WZ-050	45-6-67				
2-D8	ED237960	Zener Diode WZ-150	45-6-67				
2-D9	ED322238	Silicon Stack 1B4B41	45-2-97				
2-D10to14	ED557447	Silicon Diode 1S1588	45-3-22				
2-DVC1,2	EC616342	Trimmer/C. CTY122D33 15PF	24-2-32				
2-SW1,2,3	ES322243	Push SW. JK-2108	25-5-359				
2-VR1	EV593368	Semi-Fixed/Vol. V10K8-4-2 B30K	36-10-250				
2-VR2,3	EV550023	Semi-Fixed/Vol. V10K8-4-2 100K (B)	36-10-250				
2-VR4,5	EV551452	Semi-Fixed/Vol. (Solid Type) SR19R 22kΩ	36-19-10				
2-VR6	EV604438	Semi-Fixed/Vol. V10K8-4-2 B10K	36-10-250				
2-L1	EO539820	Peaking Coil 2.2μH (K)	23-1-187				
2-T2	EO307186	OSC Coil RWR-43208N	23-4-47				
2-T3	EO322239	DET Coil Q228CEL-1072N	23-1-383				
2-T4	BT293398	AM-IF Trans. RMC-42246BCH 468kHz	23-1-276				
2-T5	BT307204	AM-IF Trans. CFMA-008	53-1-131				
2-T6	EO322241	MPX Coil CANS-3700Z	23-1-386				
2-FL1,2	ER307201	Ceramic Filter SFE10.7mm	53-1-132				
2-FL3	ER322237	Low Pass Filter 209BLRG-3368N	23-1-384				
2-FL4,5	ER322181	Low Pass Filter 208BLRC-3415N	23-1-385				
2-R12	ER322591	Carbon/R. F 1/4 WS 100 ohms (J)	35-11-30				
2-R42	ER324337	Carbon/R. F 1/4WS 56 ohms (J)	35-11-30				
2-R51	ER322591	Carbon/R. F 1/4WS 100 ohms (J)	35-11-30				
2-R56	ER324337	Carbon/R. F 1/4WS 56 ohms (J)	35-11-30				
2-R68	ER324337	Carbon/R. F 1/4WS 56 ohms (J)	35-11-30				
2-R69	ER324337	Carbon/R. F 1/4WS 56 ohms (J)	35-11-30				
2-R85	ER324337	Carbon/R. F 1/4WS 56 ohms (J)	35-11-30				
2-R102	ER322591	Carbon/R. F 1/4WS 100 ohms (J)	35-11-30				



### 3. FINAL ASSEMBLY BLOCK

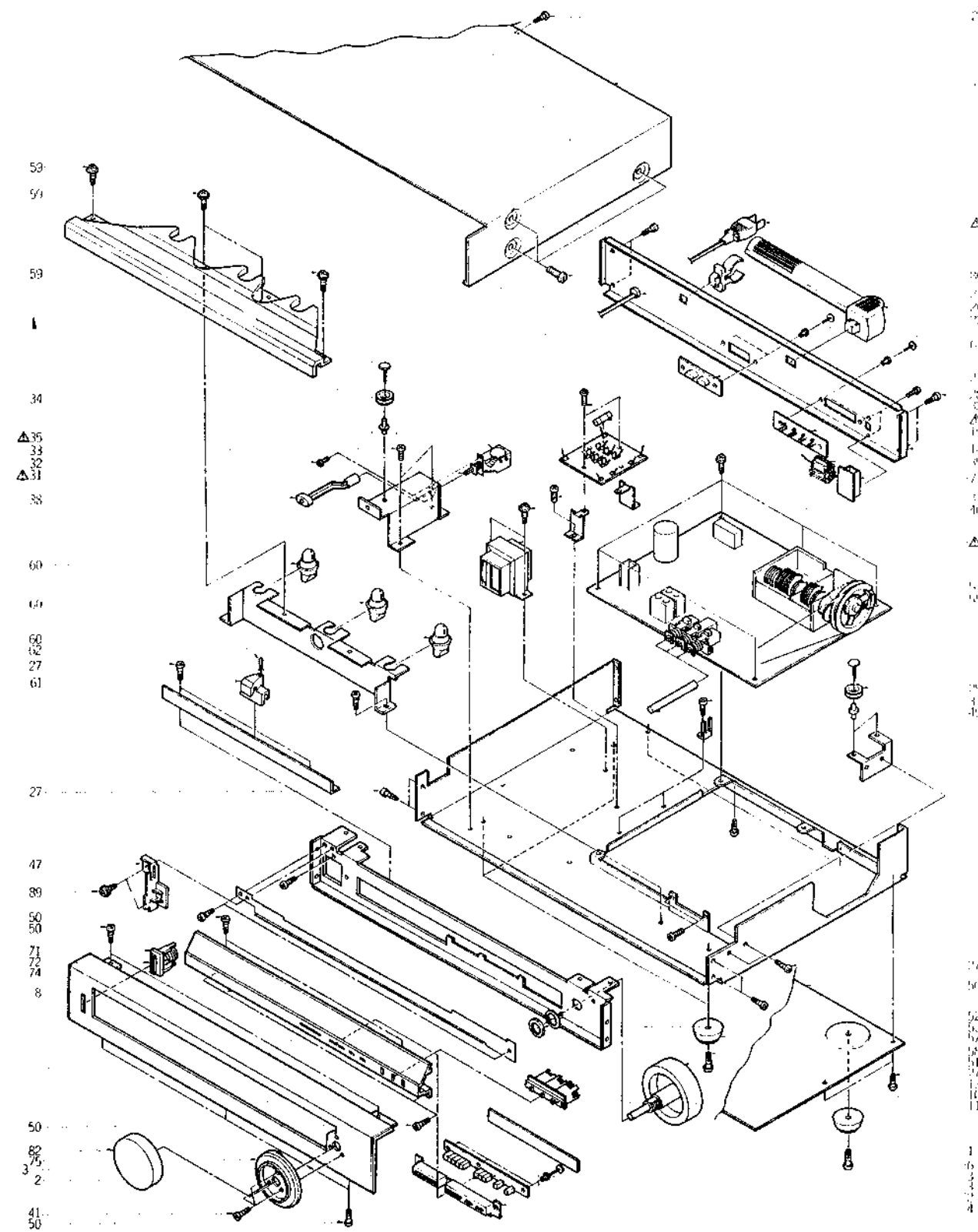

### FINAL ASSEMBLY BLOCK

Ref. No.	Parts No.	Description	Schematic No.	Ref. No.	Parts No.	Description	Schematic No.
<b>LED P.C BOARD BLOCK</b>							
3-1	ED322184	LED SLP-152D	45-15-40	3-51	TA322249	Tuning Wheel Assy	9-3-51
3-2	ED322215	LED SLP-251D	45-15-39	3-52	ZW436026	Washer (SPC) D9.2x15x0.5t	7-1-56
3-3	ED322247	LED SLP-151D	45-15-41	3-53	ZW554624	E Jack Nut	9-3-52
3-4	SE322190	LED Escutcheon	ATK-2021	3-54	TA322250	Dial Wheel Assy	1-2-1
3-5x	SE322191	LED Escutcheon (BL)	ATK-2021	3-55	TA307160	Dial String TK-1064 D0.5	ATK-2030
3-6	ZW698308	Nylon Rivet (NRB) 3x5.5 (Black)	2-1-51	3-56	SP322202	Bottom Plate	PC-2032
<b>ATTENUATOR P.C BOARD BLOCK</b>							
3-7	ES324238	Slide SW. SSB02204	25-1-185	3-57	SA311742	Circular Foot	
<b>SCALE PANEL BLOCK</b>							
3-8	SP322182	Scale Panel (A)	ATK-2016, 2017	3-58	ZS565942	Tapping Screw, #2 pan 4x8	
3-9x	SP322183	Scale Panel (A-BL)	ATK-2016, 2017	3-59	ZS225134	Tapping Screw #2, pan 3x10 W=8	
3-10	SE322188	Escutcheon (B)	ATK-2019	3-60	EL322236	Lamp (Cord Type) 8V 300mA (400mmx2)	28-2-83
3-11	SB322186	Button (B)	ATK-2018	3-61	TA320234	Pointer Part AT-K02	ATK-2038
3-12x	SB322187	Button (B-BL)	ATK-2018	3-62	EL322234	Lamp (Cord Type) 8V 50mA (350mmx2)	18-2-82
3-13	ZG322189	Spring (B)	ATK-2020	3-63	EF309389	△ Fuse 400mA 250V (U/T)	39-1-44
<b>REAR PANEL BLOCK</b>							
3-14	SP322168	Rear Panel (U/T-1)	ATK-2007	3-64x	EF309392	△ Fuse 1.25A 125V (CSA, AAL)	39-1-45
3-15x	SP322170	Rear Panel (CSA-1)	ATK-2007	3-65x	EF315334	△ Fuse 250mA 125V (CSA, AAL)	39-1-45
3-16x	SP322169	Rear Panel (AAL-1)	ATK-2007	3-66x	EF602550	△ Fuse (SEMKO T Type) 1.25AT 250V (CEE, UK, SAA)	39-1-53
3-17x	SP322171	Rear Panel (CEE-1)	ATK-2008	3-67x	EF300588	△ Fuse (EAWK) (CEE, UK, SAA)	39-1-60
3-18x	SP322172	Rear Panel (UK, SAA-1)	ATK-2008	<b>FRONT PANEL BLOCK</b>			
3-19	EJ603685	Antenna Terminal Plate 4P	32-1-52	3-68	BD320250	Front Panel BLK AT-K02	ATK-2052
3-20	EE322245	Bar Ant	55-1-62	3-69x	BD320251	Front Panel BLK AT-K02-BL	ATK-2052
3-21	EJ322246	2P Pin Jack	32-1-108	3-70x	BD320268	Front Panel BLK AT-K02-S	ATK-2052
3-22	ZW281463	Nylon Rivet (NRB) 3x6.5 (Black)	2-1-51	3-71	SE322578	Escutcheon (A)	ATK-2013
3-23	EZ631945	Strain Relief SR-4N-4 (U/T, CSA, AAL)	2-7-49	3-72	SB322576	Button (A)	ATK-2012
3-24	EW306428	△ AC Cord (U/T)	26-1-44	3-73x	SB322577	Button (A-BL)	ATK-2012
3-25x	EW305691	△ AC Cord CUL (CSA, AAL)	26-3-15	3-74	ZG322579	Spring (A)	ATK-2014
3-26x	EJ301513	△ Inlet 2P (CEE, UK, SAA)	31-1-200	3-75	TA322204	Tuning Knob Cover (A)	ATK-2032
3-27	ZS325495	Tapping Screw, #2 BR 3x6		3-76x	TA322205	Tuning Knob Cover (A-BL)	ATK-2032
3-28	ZS308846	Tapping Screw, #2 BR 3x8 (Oval Neck)	7-1-69	<b>FINAL ASSEMBLY BLOCK</b>			
3-29	MR308836	Pulley	13-2-40	3-77	BC322209	Upper Cover (A)	ATK-2034
3-30x	ES665875	△ Push SW. SDG1P-J TV-3 UL/CSA (CSA, AAL)	25-5-199	3-78x	BC322212	Upper Cover (B) (AAL)	ATK-2034
3-31	ES310839	△ Push SW. SDG1P-E 5A/80A 250V (U/T, CEE, UK, SAA)	25-5-310	3-79x	BC322210	Upper Cover (A-BL)	ATK-2034
3-32	ZS379350	Screw, pan 3x6		3-80	ZS322570	S-Tight Screw, bind 4x8	
3-33	ZS306021	S-Tight Screw, pan 3x6		3-81x	ZS322580	S-Tight Screw, bind 4x8 (AAL, BL)	
3-34	MZ307170	Pulley	13-2-39	3-82	SK322207	Tuning Knob (A)	1T K-2033
3-35	EC204671	△ Ceramic/C. DD31-6E 0.01μF (P) 500WV (U/T)	24-5-66	3-83x	SK322208	Tuning Knob (A-BL)	1T K-2033
3-36x	EC314688	△ Ceramic/C. DE7150 FZ 0.01μF (P) 125W (CSA, AAL)	24-5-87	3-84x	SK324433	Tuning Knob (B) (S)	1T K-2041
3-37x	EC301320	△ MP/C. 4700PF (M) 250WV (CEE, UK, SAA)	24-9-122	3-85x	ZW305013	Pop Rivet D3.2 (AAL)	1-6-9
3-38	TC309268	Push Rod	CF-6005	3-86x	EW315767	AC Cord Set CEE 2 Cores (CEE)	16-3-72
3-39	BT444137	Balun Trans. 75 ohm-300 ohm	23-1-129	3-87x	EW302995	AC Cord Set BEAB 2 Cores (UK)	16-3-57
3-40	ZS297641	Tapping Screw, #2, bind 3x8 W=10		3-88x	EW322401	AC Cord Set SAA 2 Cores (SAA)	16-3-77
3-41	ZS462194	Tapping Screw, #2 pan 3x8 (W=8)		3-89	ZS498273	Tapping Screw #2, BR 3x8 W=8	
3-42	BT322177	△ Power Trans. AT-K02T-70 (U/T)	38-4-777				
3-43x	BT322217	△ Power Trans. AT-K02T-30 (CSA, AAL)	38-4-778				
3-44x	BT322206	△ Power Trans. AT-K02T-40 (CEE)	38-4-779				
3-45x	BT322218	△ Power Trans. AT-K02T-50 (UK, SAA)	38-4-780				
3-46	ZS315511	S-Tight Screw, pan 3x6 Cut Point	7-1-72				
3-47	MS322192	Scale Guide	ATK-2022				
3-48x	MS322193	Scale Guide (BL)	ATK-2022				
3-49	SZ322214	Tube (A)	ATK-2036				
3-50	ZS447840	Tapping Screw, #2 BR 3x8					

When ordering parts, please quote Parts Number, Description and Model Number.

## II. MODEL AM-U02

### 1. RECOMMENDED SPARE PARTS LIST

Because, if the parts listed below are on hand, almost any repair can be accomplished, we suggest that you stock these Recommended Spare Parts Items.

Parts No.	Description	Notes
BA320192	Main Amp PCB Comp. AM-U02	
BA320136	Main Amp PCB Comp. AM-U02 (CEE)	
BA320135	Main Amp PCB Comp. AM-U02 (CSA)	
BA319362	Main Amp PCB Comp. AM-U02 (JPN)	
BT323582	△ Power Trans. AM-U02T-10	(JPN)
BT322572	△ Power Trans. AM-U02T-20	(AAL)
BT322573	△ Power Trans. AM-U02T-30	(CSA)
BT322574	△ Power Trans. AM-U02T-40	(CEE)
BT322575	△ Power Trans. AM-U02T-50	(UK, SAA)
BT322571	△ Power Trans. AM-U02T-70	(U/T)
EC321302	△ Ceramic/C. E 0.01μF (Z) 250VAC	(U/T, JPN)
EC204671	△ Ceramic/C. DD31-6E 0.01μF (P) 500WV	(U/T)
EC314688	△ Ceramic/C. DE7150 FZ 0.01μF (P) 125WV	(CSA, AAL)
EC301320	△ MP/C. 4700PF (M) 250WV	(CEE, SAA, UK)
EC320307	Elect./C. 6800μF 40WV	
ED562386	Germanium Diode 1S188AM	
ED322772	LED SLP-155D-01	
ED322773	LED SLP-255D-01	
ED214457	Silicon Diode 1S2472	
ED316143	Silicon Diode 1S2473-HS	
ED322589	Silicon Stack 3D4B41	
ED322810	Zener Diode WZ-040	
ED557111	Zener Diode WZ-210	
ED323530	Zener Diode 05Z-12U	
ED322774	Zener Diode 05Z5.1U	
EF306949	△ Fuse 1.25A 250V	(U/T)
EF311839	△ Fuse 1.6A 250V	(U/T, JPN)
EF306956	△ Fuse 2.5A 125V	(CSA, AAL)
EF306951	△ Fuse 2.5A 250V	(JPN)
EF306954	△ Fuse 2A 125V	(CSA, AAL)
EF306950	△ Fuse 2A 250V	(JPN)
EF300583	△ Fuse (EAK) 1.25AT	(CEE, UK, SAA)
EF300581	△ Fuse (EAK) 2AT	(CEE, UK, SAA)
EF300579	△ Fuse (EAK) 3.15AT	(CEE, UK, SAA)
EI322791	IC LC7556	
EI322583	IC STK-0030	
EI322587	IC STK-3042	
EI322588	IC TA7136AP	
EI322599	IC TA75458S	
EJ301199	Headphone Jack 3P64M	
EM322584	Bar Meter FIP48DW16YS	

Parts No.	Description	Notes
EO650823	Phase Compensation Coil 2.2 $\mu$ H (K)	
ES315159	$\Delta$ Push SW. SDG1P (JPN)	
ES310839	$\Delta$ Push SW. SDG1P-E 5A/80A 250V	(CEE, SAA, UK)
ES665875	$\Delta$ Push SW. SDG1P-J TV-3 UL/CSA	(CSA, AAL)
ES655806	$\Delta$ Push SW. SDG1P-J TV3 CSA	(U/T)
ES324348	Push SW. J-K2091	
ES324344	Push SW. J-K2102	
ES322586	Rotary Slide SW. SRZW43N	
ES322776	Rotary Slide SW. SRZW44S	
ET322778	Transistor 2SA608K-NP (E) (F) (G)	
ET322244	Transistor 2SA608K-NP (F) (G)	
ET322598	Transistor 2SB632K (E) (F)	
ET322775	Transistor 2SC536K-NP (E) (F) (G)	
ET310148	Transistor 2SD612K (E) (F)	
EV322789	Semi-Fixed/Vol. V10K8-1-2 2k $\Omega$	
EV324345	Single-Axial 2-Throw/Vol. V16L4G3N 100k $\Omega$ x2	
EV324346	Single-Axial 2-Throw/Vol. V16L4G3N 250k $\Omega$ x2	
EV322781	2-Throw Slide/Vol. MDV3B001-250k $\Omega$ x2	
EW306427	$\Delta$ AC Cord (JPN)	
EW306428	$\Delta$ AC Cord (U/T)	
EW305691	$\Delta$ AC Cord CUL	(CSA, AAL)

## 2. MAIN AMP P.C BOARD (AMU-2001A) BLOCK

Symbol No.	Parts No.	Description	Schematic No.
2-1	BA320192	Main Amp PCB Comp. AM-U02 (U/T)	AMU-2001A
2-2	BA319362	Main Amp PCB Comp. AM-U02 (JPN)	AMU-2001A
2-3	BA320135	Main Amp PCB Comp. AM-U02 (CSA)	AMU-2001A
2-4	BA320136	Main Amp PCB Comp. (CSA, AAL) AM-U02 (CEE)	AMU-2001A
2-IC1	EI322588	IC TA7136AP (CEE, UK, SAA)	45-8-414
2-IC2	EI322587	IC STK-3042-AL	45-8-416
2-TR1	ET322775	Transistor 2SC536K-NP (E) (F) (G)	45-1-362
2-TR2,3	ET322778	Transistor 2SA608K-NP (E) (F) (G)	45-1-375
2-TR4to6	ET322775	Transistor 2SC536K-NP (E) (F) (G)	45-1-362
2-TR7	ET322244	Transistor 2SA608K-NP (F) (G)	45-1-375
2-TR8,9	ET322778	Transistor 2SA608K-NP (E) (F) (G)	45-1-375
2-TR10	ET310148	Transistor 2SD612K (E) (F)	45-1-308
2-TR11	ET322598	Transistor 2SB632K (E) (F)	45-1-374
2-D1to3	ED316143	Silicon Diode 1S2473-HS	45-3-53
2-D4	ED214457	Silicon Diode 1S2472	45-3-41
2-D5,6	ED322589	Silicon Stack 3D4B41	45-2-96
2-D7,8	ED557111	Zener Diode WZ-210	45-6-67
2-D9	ED214457	Silicon Diode 1S2472	45-3-41
2-L1	EO650823	Phase Compensation Coil 2.2μH (K)	23-1-239
2-J1	EJ698051	Din Jack	31-1-158
2-J2,3	EJ293365	Pin Jack 4P	31-1-197
2-J4	EJ293376	Pin Jack 6P	31-1-198
2-SW1,2	ES324344	Push SW. J-K2102	25-5-383
2-SW3	ES322586	Rotary Slide SW. SRZW43N	25-6-189
2-R4	ER317686	Metal Oxide Film/R. 1/4WS 1K (F)	35-17-20
2-R5	ER322293	Metal Film/R. 1/4W 464K (F)	35-17-20
2-R6	ER322294	Metal Film/R. 1/4W 37.4K (F)	35-17-20
2-R30	ER322590	Cement/R. (Metal Plate) 5W (0.47+0.47) ohms (K)	35-16-84
2-R33,34	ER311673	Metal Oxide Film/R. 2W 3.3K (K)	35-15-8
2-R48	ER324337	Carbon/R. F 1/4WS 56 ohms (J)	35-11-30
2-R49,50	ER322787	Carbon/R. F 1/4WS 10 ohms (J)	35-11-36
2-C3	EC324379	NP/C. 2.2μF (M) 50WV	24-17-36
2-C7	EC322788	Styrol/C. 6970PF(J) 50WV	24-11-18
2-C8	EC322800	Styrol/C. 2040PF(J) 50WV	24-11-18
2-C10	EC324376	NP/C. 1μF (M) 50WV	24-17-36
2-C13	EC324379	NP/C. 2.2μF (M) 50WV	24-17-36
2-C22	EC322290	Solid Aluminum/C. 3.3μF (M) 25WV	24-19-3
2-C23,24	EC326583	Metalized Mylar/C. (Vert.) 0.047μF (K) 400WV	24-16-29
2-C33to36	EC320307	Elect./C. 6800μF 40WV	24-12-63
2-5	ZS447840	Tapping Screw, #2 BR 3x8	
2-6	ZS498273	Tapping Screw, #2, BR 3x8 W=8	
2-7	ZS422076	Screw, pan 3x5	

## 3. CONTROL P.C BOARD (AMU-2007) BLOCK

Symbol No.	Parts No.	Description	Schematic No.
3-IC1	EI322588	IC TA7136AP	45-8-414
3-VR1	EV324346	Single-Axial 2-Throw/Vol. V16L4G3N 250kZx2	36-22-65
3-VR2	EV322781	2-Throw Slide/Vol. MDV3B001-250kBX2	36-27-8
3-VR3,4	EV324345	Single-Axial 2-Throw/Vol. V16L4G3N 100kCx2	36-22-64
3-C2	EC324376	NP/C. 1μF (M) 50WV	24-17-36
3-C4	EC324376	NP/C. 1μF (M) 50WV	24-17-36
3-C7	EC323260	NP/C. 10μF (M) 16WV	24-17-36
3-1	ZS422076	Screw, pan 3x5	

#### 4. BAR METER P.C BOARD (AMU-2006) BLOCK

Symbol No.	Parts No.	Description	Schematic No.
4-IC1	EI322791	IC LC7556	45-8-425
4-D1	ED322774	Zener Diode 05Z5.1U	45-6-76
4-D2	ED322810	Zener Diode WZ-040	45-6-67
4-IND1	EM322584	Bar Meter FIP48DW16YS	59-1-2
4-1	ZS422076	Screw, pan 3x5	

#### 6. LOUDNESS P.C BOARD (AMU-2003) BLOCK

Symbol No.	Parts No.	Description	Schematic No.
6-SW1	ES322776	Rotary Slide SW. SRZW44S	25-6-188
6-C2	EC321173	Styrol/C. 180PF (J) 50WV	24-11-14
6-C3	EC306988	Styrol/C. 330PF (J) 50WV	24-11-14

#### 5. BAR METER DRIVE P.C BOARD (AMU-2004) BLOCK

Symbol No.	Parts No.	Description	Schematic No.
5-IC1	EI322599	IC TA75458S	45-8-415
5-TR1,2	ET322775	Transistor 2SC536K-NP (E) (F) (G)	45-1-362
5-D1	ED562386	Germanium Diode 1S188AM	45-3-24
5-D2	ED316143	Silicon Diode 1S2473-HS	45-3-53
5-D3	ED323530	Zener Diode 05Z-12U	45-6-76
5-VR1	EV322789	Semi-Fixed/Vol. V10K8-1-2 2kB	36-10-255
5-C1	EC657044	NP/C. (Vert. Type) 1μF (M) 50WV	24-17-26
5-1	ZS325495	Tapping Screw, #2 BR 3x6	

#### 7. PUSH SW. P.C BOARD (AMU-2005) BLOCK

Symbol No.	Parts No.	Description	Schematic No.
7-SW1 to 6	ES324348	Push SW. J-K2091	25-3-384
7-R1	ER511288	Metal Oxide Film/R. 1W 180 ohm (K)	35-15-10
7-C3	EC324378	Solid Aluminum/C. 0.33μF (M) 25WV	24-19-3

# INDEX

## 1. MODEL AT-K02

Parts No.	Ref. No. & Symbol No.	Parts No.	Ref. No. & Symbol No.	Parts No.	Ref. No. & Symbol No.	Parts No.	Ref. No. & Symbol No.	Parts No.	Ref. No. & Symbol No.
BA320243	2-1	ED322184	3-1	ER322591	2-R12	EW322401	3-88x	TA322205	3-76x
BA320244	2-2	ED322215	3-2	ER322591	2-R51	EZ631945	3-23	TA322249	3-51
BA320245	2-3	ED322238	2-D9	ER322591	2-R102	MR308836	3-29	TA322250	3-54
BC322209	3-77	ED322247	3-3	ER324337	2-R42	MS322192	3-47	TC309268	3-38
BC322210	3-79x	ED557447	2-D1to6	ER324337	2-R56	MS322193	3-48x	ZG322189	3-13
BC322212	3-78x	ED557447	2-D10to14	ER324337	2-R68	MZ307170	3-34	ZG322579	3-74
BD320250	3-68	EE322242	2-4	ER324337	2-R69	SA311742	3-57	ZS225134	3-59
BD320251	3-69x	EE322245	3-20	ER324337	2-R85	SB322186	3-11	ZS297641	3-40
BD320268	3-70x	EF300588	3-67x	ER324337	2-R109	SB322187	3-12x	ZS306021	3-33
BT293398	2-T4	EF309389	3-63	ES310839	3-31	SB322576	3-72	ZS308846	3-28
BT307204	2-T5	EF309392	3-64x	ES322243	2-SW1,2,3	SB322577	3-73x	ZS315511	3-46
BT322177	3-42	EF315334	3-65x	ES324238	3-7	SE322188	3-10	ZS322570	3-80
BT322206	3-44x	EF602550	3-66x	ES665875	3-30x	SE322190	3-4	ZS322580	3-81x
BT322217	3-43x	EI293185	2-IC3	ET307234	2-TR24,25	SE322191	3-5x	ZS325495	2-5
BT322218	3-45x	EI315491	2-IC4	ET316643	2-TR5to14	SE322578	3-71	ZS325495	3-27
BT444137	3-39	EI322185	2-IC2	ET316643	2-TR16to20	SK322207	3-82	ZS379350	3-32
EC204671	3-35	EI322248	2-IC1	ET316643	2-TR22,23	SK322208	3-83x	ZS447840	3-50
EC301320	3-37x	EJ301513	3-26x	ET316643	2-TR27	SK324433	3-84x	ZS462194	3-41
EC313534	2-C42	EJ322246	3-21	ET322244	2-TR3,4	SP322168	3-14	ZS498273	3-89
EC314688	3-36x	EJ603685	3-19	ET322244	2-TR28	SP322169	3-16x	ZS565942	3-58
EC315335	2-C45	EL322234	3-62	ET452531	2-TR21	SP322170	3-15x	ZW281463	3-22
EC435690	2-C44	EL322236	3-60	ET618873	2-TR1,2	SP322171	3-17x	ZW305013	3-85x
EC513990	2-C31	EO307186	2-T2	EV550023	2-VR2,3	SP322172	3-18x	ZW436026	3-52
EC513990	2-C32	EO322239	2-T3	EV551452	2-VR4,5	SP322182	3-8	ZW554624	3-53
EC514001	2-C83	EO322241	2-T6	EV593368	2-VR1	SP322183	3-9x	ZW698308	3-6
EC616342	2-DVC1,2	EO539820	2-L1	EV604438	2-VR6	SP322183	3-9x		
EC672287	2-C31	ER307196	2-R132	EW302995	3-87x	SP322202	3-56		
EC672287	2-C32	ER307201	2-FL1,2	EW305691	3-25x	SZ322214	3-49		
ED237960	2-D8	ER322181	2-FL4,5	EW306428	3-24	TA307160	3-55		
ED315367	2-D7	ER322237	2-FL3	EW315767	3-86x	TA320234	3-61		
						TA322204	3-75		

## 2. MODEL AM-U02

Parts No.	Ref. No. & Symbol No.	Parts No.	Ref. No. & Symbol No.	Parts No.	Ref. No. & Symbol No.	Parts No.	Ref. No. & Symbol No.	Parts No.	Ref. No. & Symbol No.
BA319362	2-2	ED562386	5-D1	ES322776	6-SW1	SP319998	8-64	ZS463353	8-36
BA320135	2-3	EF300579	8-59x	ES324344	2-SW1,2	SP319999	8-70x	ZS468101	8-91
BA320136	2-4	EF300581	8-60x	ES324348	7-SW1to6	SP322526	8-4	ZS498273	2-6
BA320192	2-1	EF300583	8-58x	ES655806	8-25	SP322527	8-7x	ZS522865	8-13
BT322571	8-42	EF300583	8-63x	ES665875	8-27x	SP322528	8-6x	ZS565942	8-99
BT322572	8-45x	EF306949	8-53	ET310148	2-TR10	SP322529	8-8x	ZW265983	8-95x
BT322573	8-44x	EF306950	8-56x	ET322244	2-TR7	SP322530	8-9x	ZW270088	8-83
BT322574	8-46x	EF306951	8-54x	ET322598	2-TR11	SP322560	8-97	ZW270123	8-38
BT322575	8-47x	EF306954	8-57x	ET322775	2-TR1	SP322561	8-100	ZW305013	8-22x
BT323582	8-43x	EF306954	8-62x	ET322775	2-TR4to6	SP322562	8-102x	ZW322110	8-39
EC204671	8-29x	EF306956	8-55x	ET322775	5-TR1,2	SP322563	8-101x	ZW324157	8-92x
EC301320	8-32x	EF311839	8-61	ET322778	2-TR2,3	SP323583	8-5x	ZW324158	8-93x
EC306988	6-C3	EI322583	8-1	ET322778	2-TR8,9	SZ322544	8-84	ZW324159	8-94x
EC314688	8-31x	EI322587	2-IC2	EV322781	3-VR2	SZ322545	8-87	ZW324161	8-96x
EC320307	2-C33to36	EI322588	2-IC1	EV322789	5-VR1	TA322261	8-40	ZW413267	8-49
EC321173	6-C2	EI322588	3-IC1	EV324345	3-VR3,4	TA322534	8-68	ZW616004	8-88
EC321302	8-30x	EI322599	5-IC1	EV324346	3-VR1	TA322535	8-71x	ZW652408	8-11
EC322290	2-C22	EI322791	4-IC1	EW305691	8-18x	TA322536	8-69	ZW698308	8-35
EC322788	2-C7	EJ293365	2-J2,3	EW306427	8-17x	TA322537	8-72x	ZW698308	8-52
EC322800	2-C8	EJ293376	2-J4	EW306428	8-16x	TA322546	8-85		
EC323260	C7	EJ296853	8-19x	EZ225145	8-21	TA322547	8-86x		
EC324376	2-C10	EJ301199	8-41	EZ631945	8-15	TA646773	8-37		
EC324376	3-C2	EJ322581	8-12	SA311742	8-98	ZG322566	8-78		
EC324376	3-C4	EJ322582	8-14	SB322557	8-76	ZG322579	8-75		
EC324378	7-C3	EJ325358	8-10	SB322558	8-77x	SG308846	8-51		
EC324379	2-C3	EJ554578	8-23	SB322576	8-73	ZS322402	8-89		
EC324379	2-C13	EJ698051	2-J1	SB322577	8-74x	ZS322570	8-103		
EC326583	2-C23,24	EM322584	4-IND1	SE322538	8-79	ZS322580	8-104x		
EC657044	5-C1	EO650823	2-L1	SE322539	8-80x	ZS325495	5-1		
ED214457	2-D4	ER311673	2-R33,34	SE322549	8-67	ZS325495	8-24		
ED214457	2-D9	ER317686	2-R4	SE322559	8-66	ZS422076	2-7		
ED316143	2-D1to3	ER322293	2-R5	SE322578	8-65	ZS422076	3-1		
ED316143	5-D2	ER322294	2-R6	SK319996	8-81	ZS422076	4-1		
ED322589	2-D5,6	ER322590	2-R30	SK319997	8-82x	ZS422076	8-33		
ED322772	8-34	ER322787	2-R49,50	SK322550	8-105	ZS424056	8-48		
ED322773	8-90	ER324337	2-R48	SK322551	8-106x	ZS434250	8-50x		
ED322774	4-D1	ER511288	7-R1	SK322553	8-107	ZS447840	2-5		
ED322810	4-D2	ES310839	8-28x	SK322554	8-108x	ZS447840	8-3		
ED323530	5-D3	ES315159	8-26x	SK322555	8-109	ZS462802	8-2		
ED557111	2-D7,8	ES322586	2-SW3	SK322556	8-110x	ZS463353	8-20x		

SECTION 4

# SCHEMATIC DIAGRAM

1. SCHEMATIC DIAGRAM OF ICs
2. AT-K02 NO. 1582437A SCHEMATIC DIAGRAM
3. AM-U02 NO. 1582436A SCHEMATIC DIAGRAM

MODEL AT-K02

LA1231

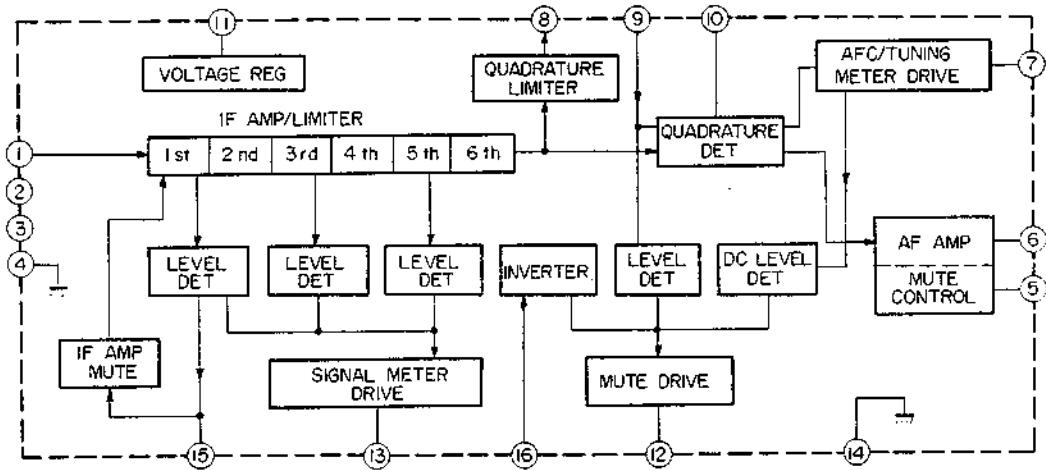

LA3380

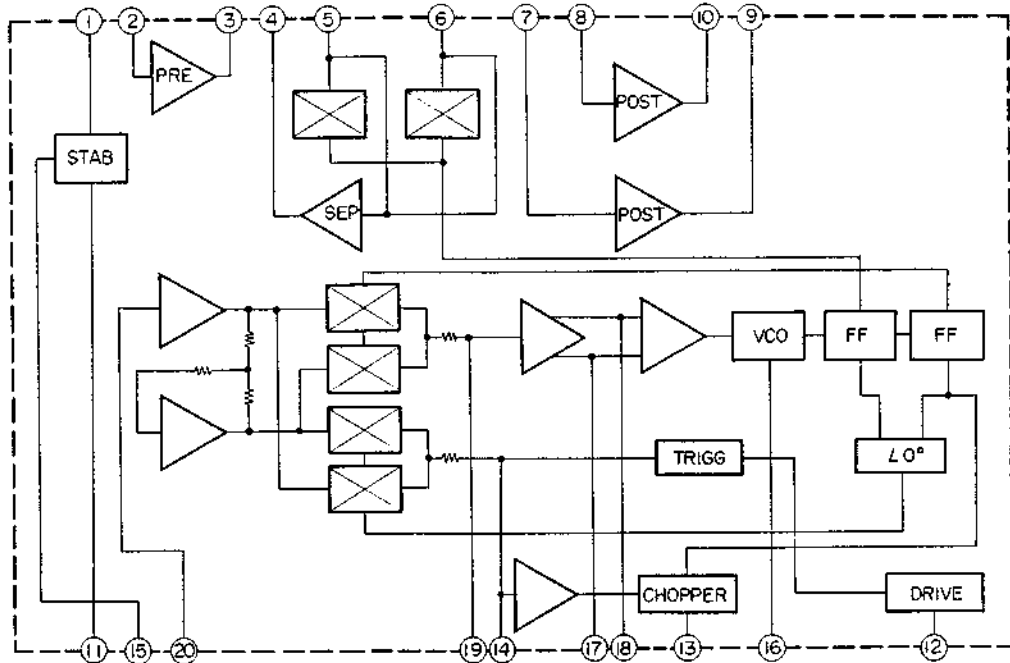

LA1240

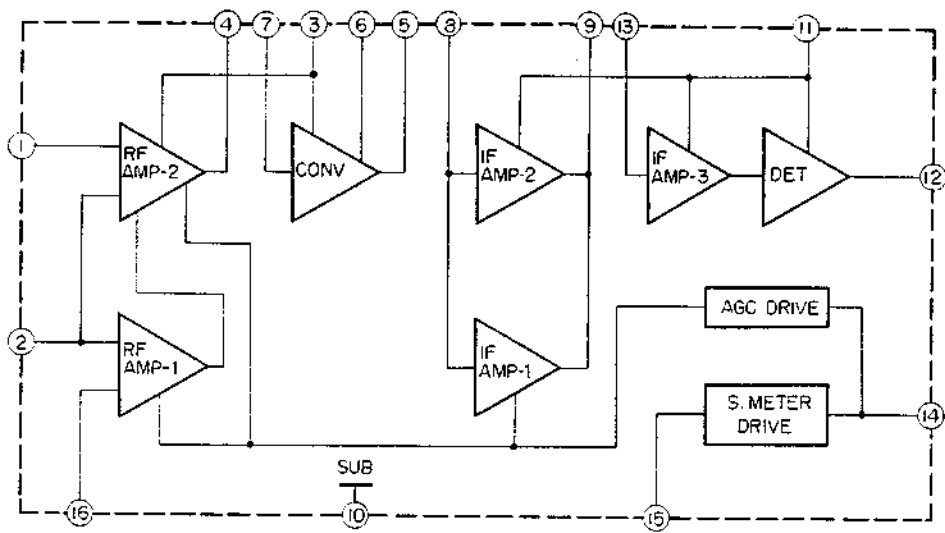

LB1405S

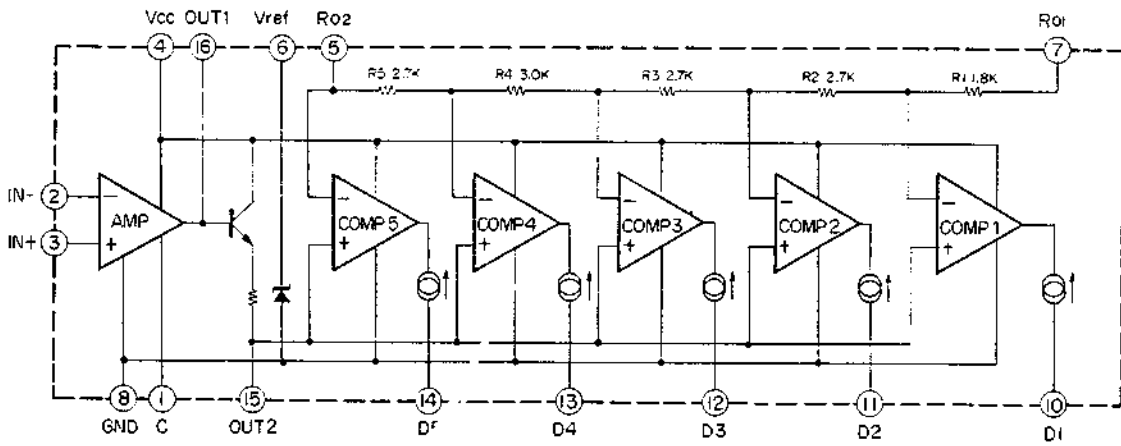



MODEL AM-U02

LC7556

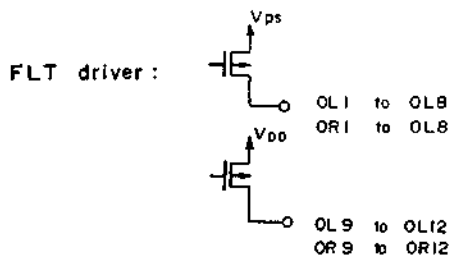
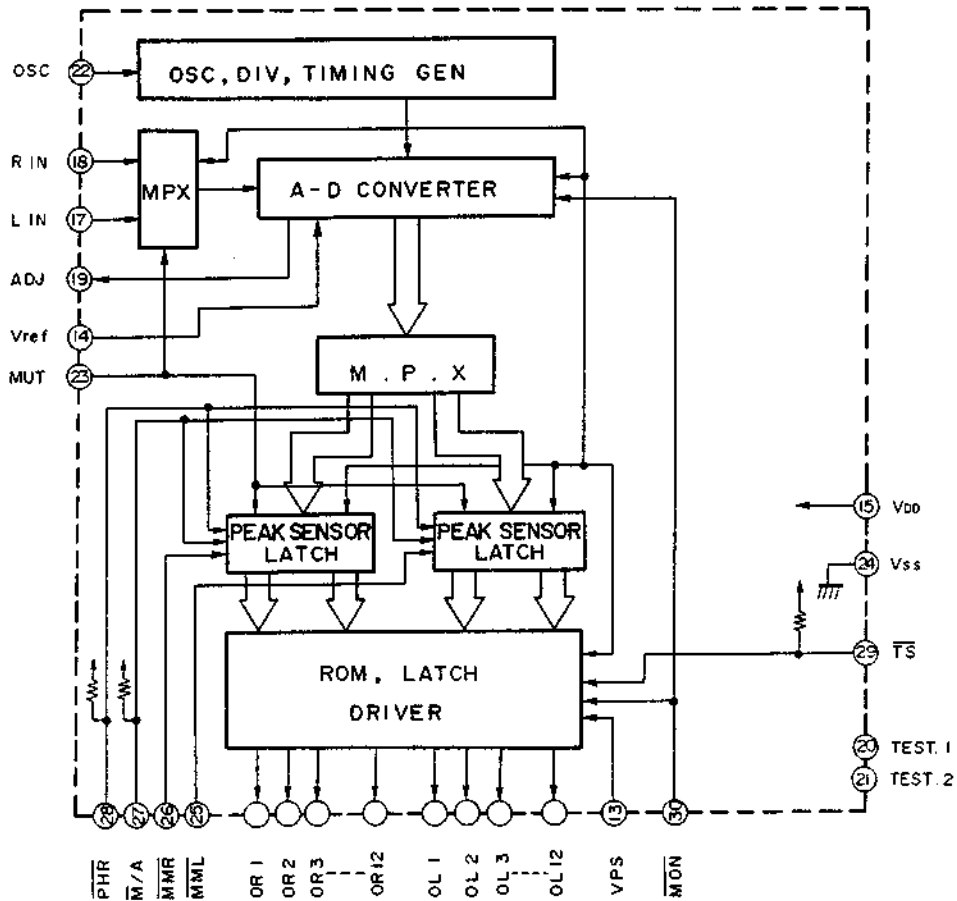

TA7136AP

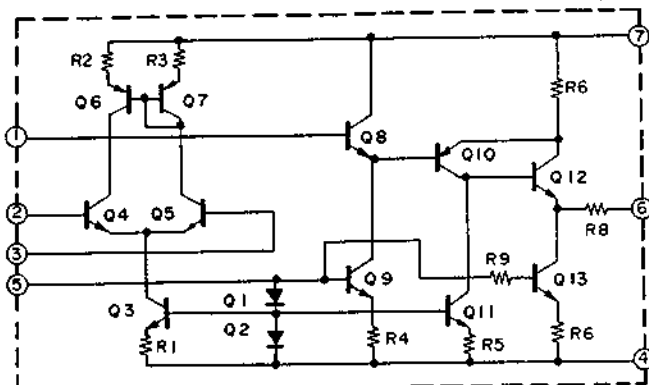

STK-0030

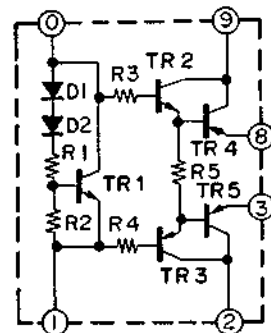

TA75458S

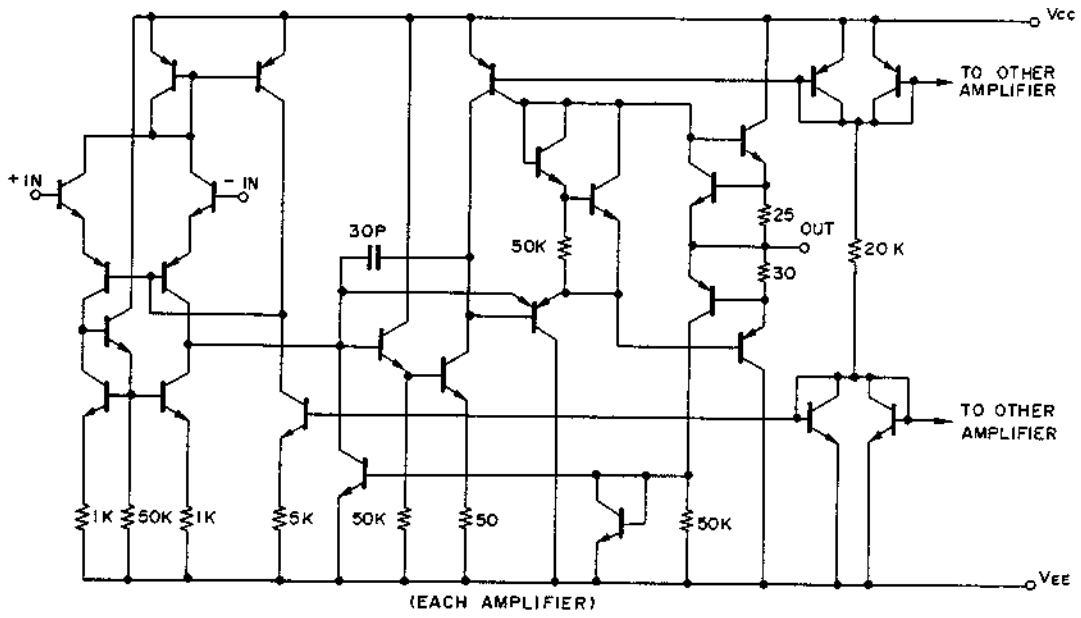
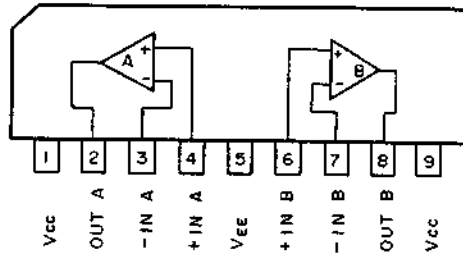

STK-3042L

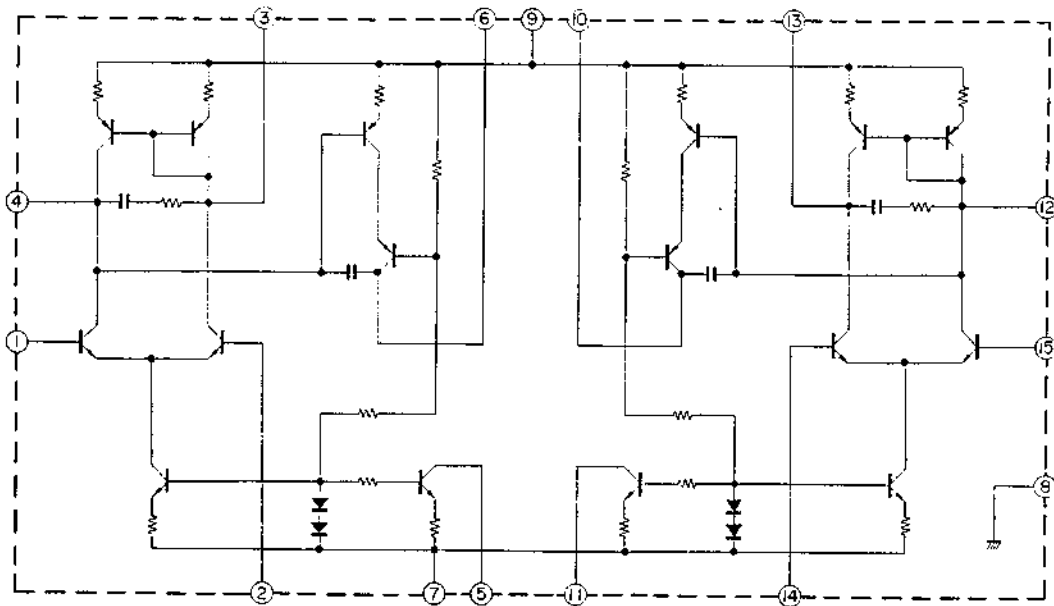

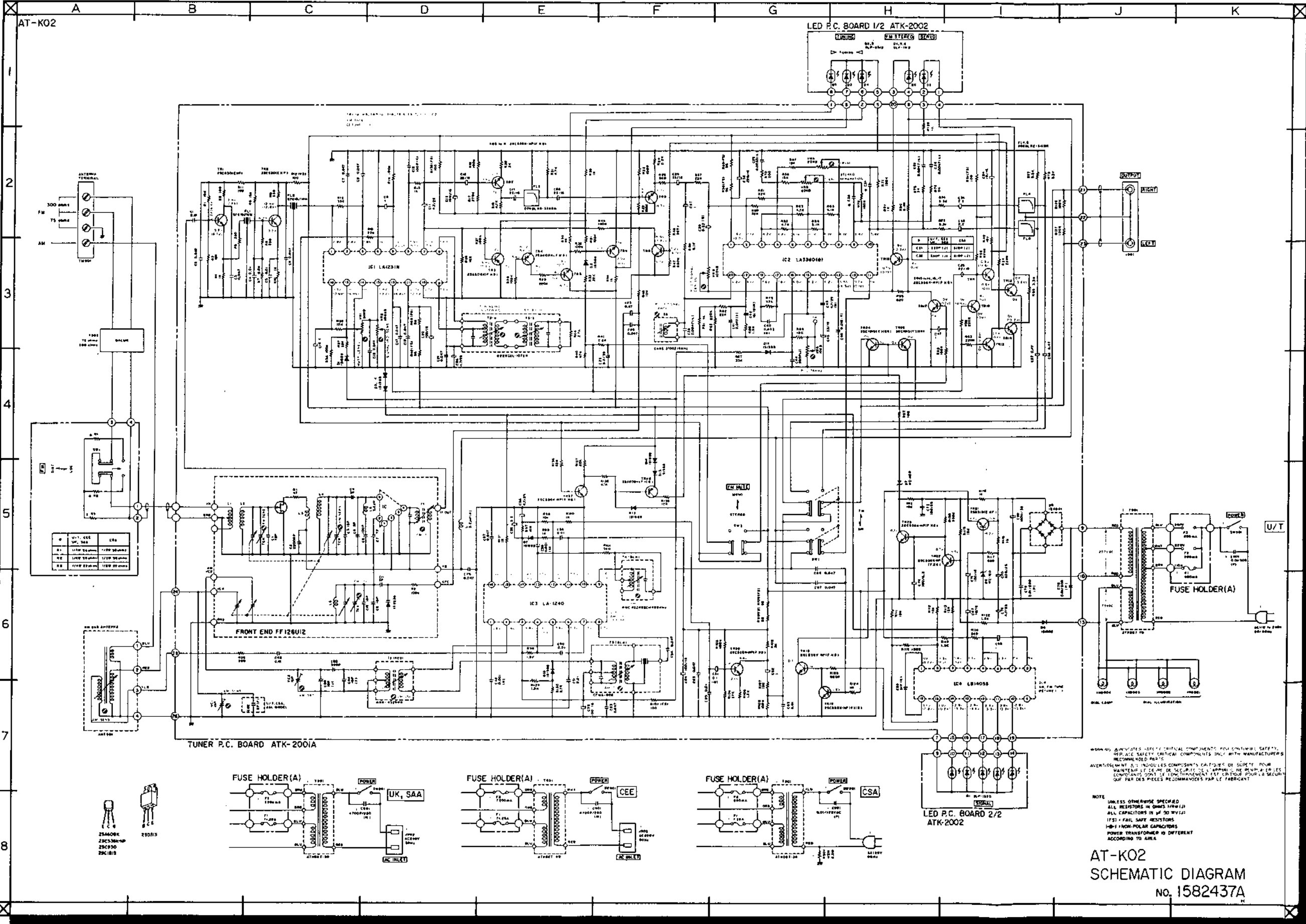

Q	VAL. RES	CR
Q1	100K 1/4W	100K 1/4W
Q2	100K 1/4W	100K 1/4W
Q3	100K 1/4W	100K 1/4W
Q4	100K 1/4W	100K 1/4W

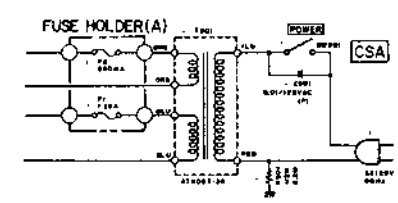
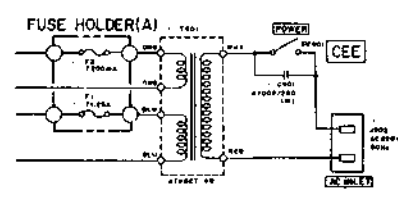
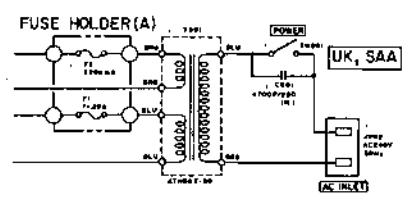

NOTE: UNLESS OTHERWISE SPECIFIED, ALL RESISTORS ARE 5% TOLERANCE. ALL CAPACITORS IN  $\mu$ F 50 VDC. (F) = FUL SAFETY RESISTORS. (H) = NON-POLAR CAPACITORS. POWER TRANSFORMER IS DIFFERENT ACCORDING TO AREA.

AT-K02  
SCHEMATIC DIAGRAM  
No. 1582437A

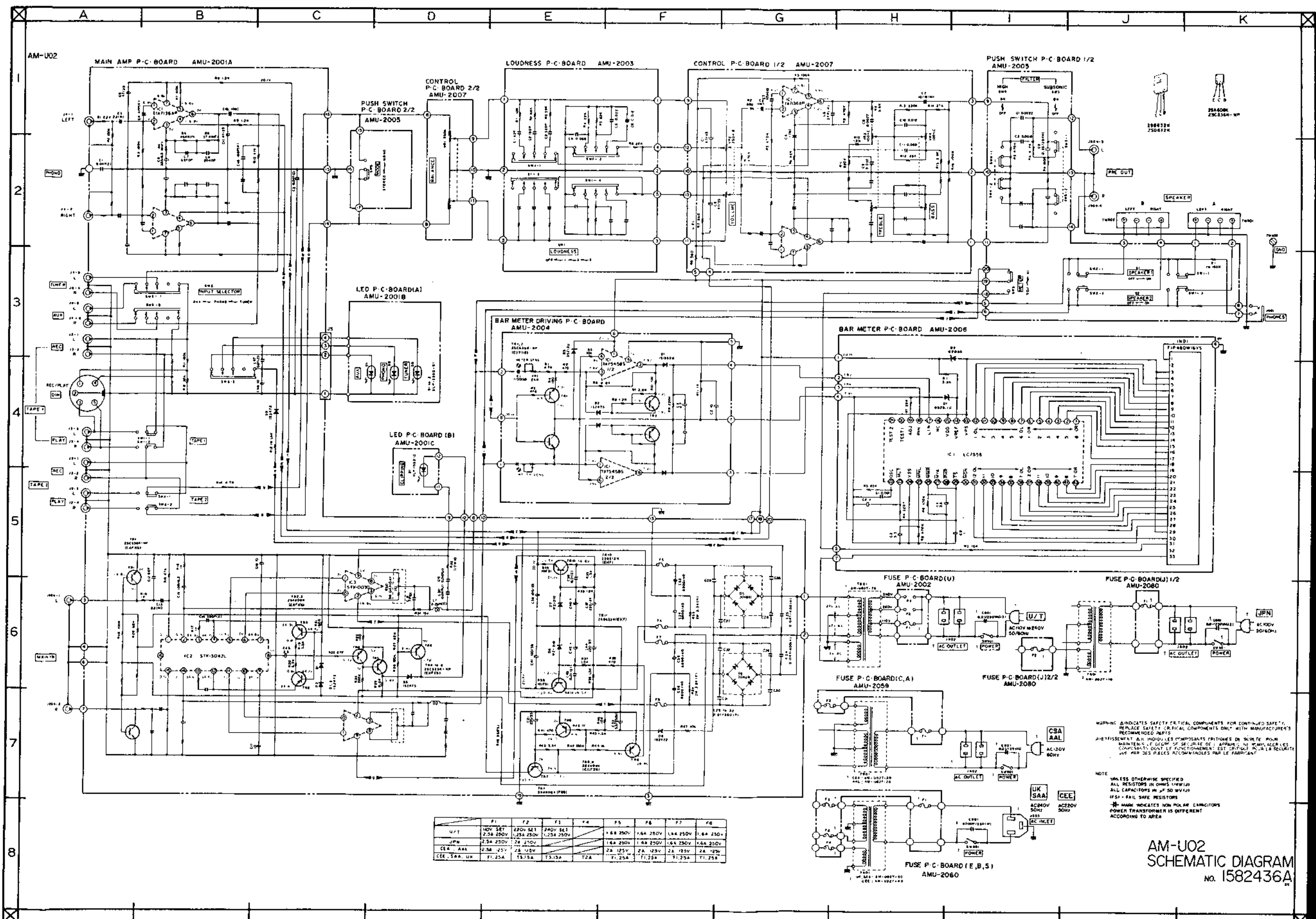

	F1	F2	F3	F4	F5	F6	F7	F8
U/T	10V 5E1	220V 5E1	240V 5E1		1.68 250V	1.6A 250V	1.6A 250V	1.6A 250V
JPN	2.5A 250V	2A 250V	1.25A 250V		1.6A 250V	1.6A 250V	1.6A 250V	1.6A 250V
CSA	2.5A 250V	2A 250V	1.25A 250V		1.6A 250V	1.6A 250V	1.6A 250V	1.6A 250V
CEE, SAA, UK	T1.25A	T1.5A	T1.5A	T2A	T1.25A	T1.25A	T1.25A	T1.25A

WARNING: INDICATES SAFETY CRITICAL COMPONENTS FOR CONTINUED SAFETY. REPLACE SAFETY CRITICAL COMPONENTS ONLY WITH MANUFACTURER'S RECOMMENDED PARTS.  
 AVERTISSEMENT: EN INDIQUE LES COMPOSANTS CRITIQUES EN SCRUTE POUR MAINTENIR LE NIVEAU DE SECURITE DE L'APPAREIL. NE REMPLACEZ LES COMPOSANTS QU'AVEC LE FONCTIONNAIRE EST CRITIQUE POUR LA SECURITE. NE REMPLACEZ QUE LES PIECES RECOMMANDEES PAR LE FABRICANT.

NOTE: UNLESS OTHERWISE SPECIFIED ALL RESISTORS IN OHMS (1/4W/1/2W) ALL CAPACITORS IN µF (50V/50V) 1/4W - FAIL SAFE RESISTORS \* MARK INDICATES NON POLAR CAPACITORS POWER TRANSFORMER IS DIFFERENT ACCORDING TO AREA

AM-U02 SCHEMATIC DIAGRAM No. 1582436A

# COMPOSITION OF VARIOUS P.C BOARDS

Main Amp. P.C Board AMU-2001A (3ED) and LED P.C Board (A)/(B) AMU-2001B/C

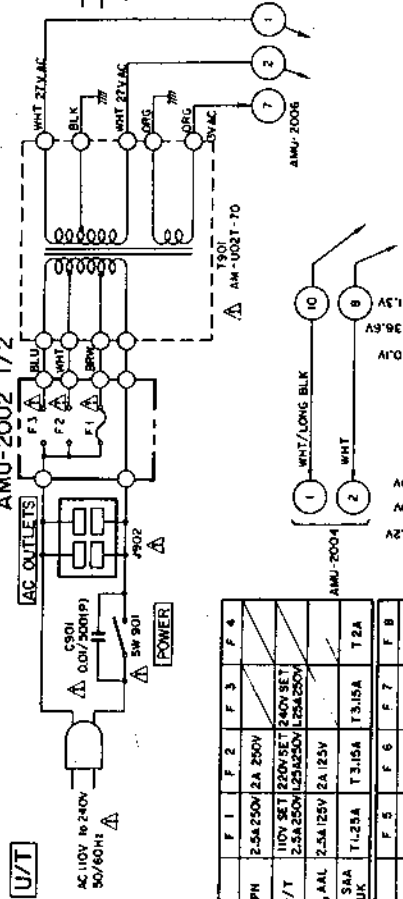
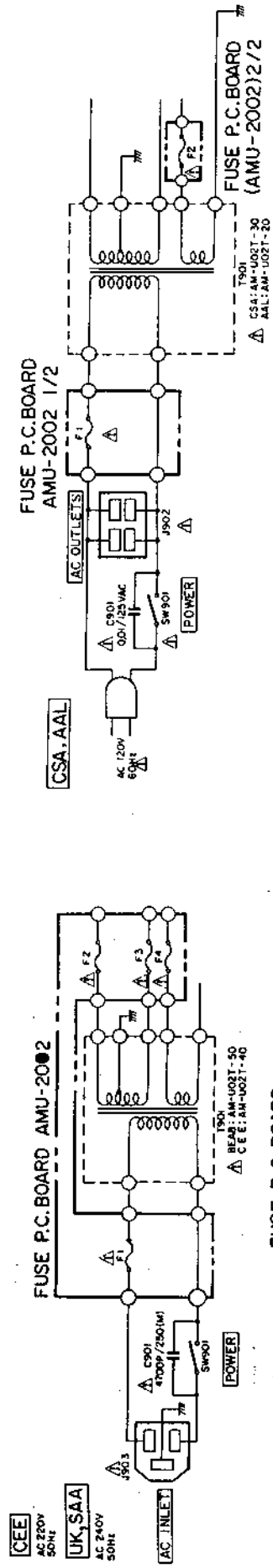

	F 1	F 2	F 3	F 4
JPN	2.5A 250V 2A 250V			
UK, SAA	100V SET 250V SET 250V SET 250V SET			
CSA, AAL	2.5A 125V 2A 125V			
CEE, SAA	T1.25A T1.25A T1.5A T1.5A	T2A		
UK				
	F 5	F 6	F 7	F 8
JPN	.6A 250V .6A 250V .6A 250V .6A 250V	.6A 250V .6A 250V		
U/T	.6A 250V .6A 250V .6A 250V .6A 250V	.6A 250V .6A 250V		
CSA, AAL	2A 125V 2A 125V 2A 125V 2A 125V	2A 125V 2A 125V		
CEE, SAA	T1.25A T1.25A T1.25A T1.25A	T1.25A T1.25A		
UK				

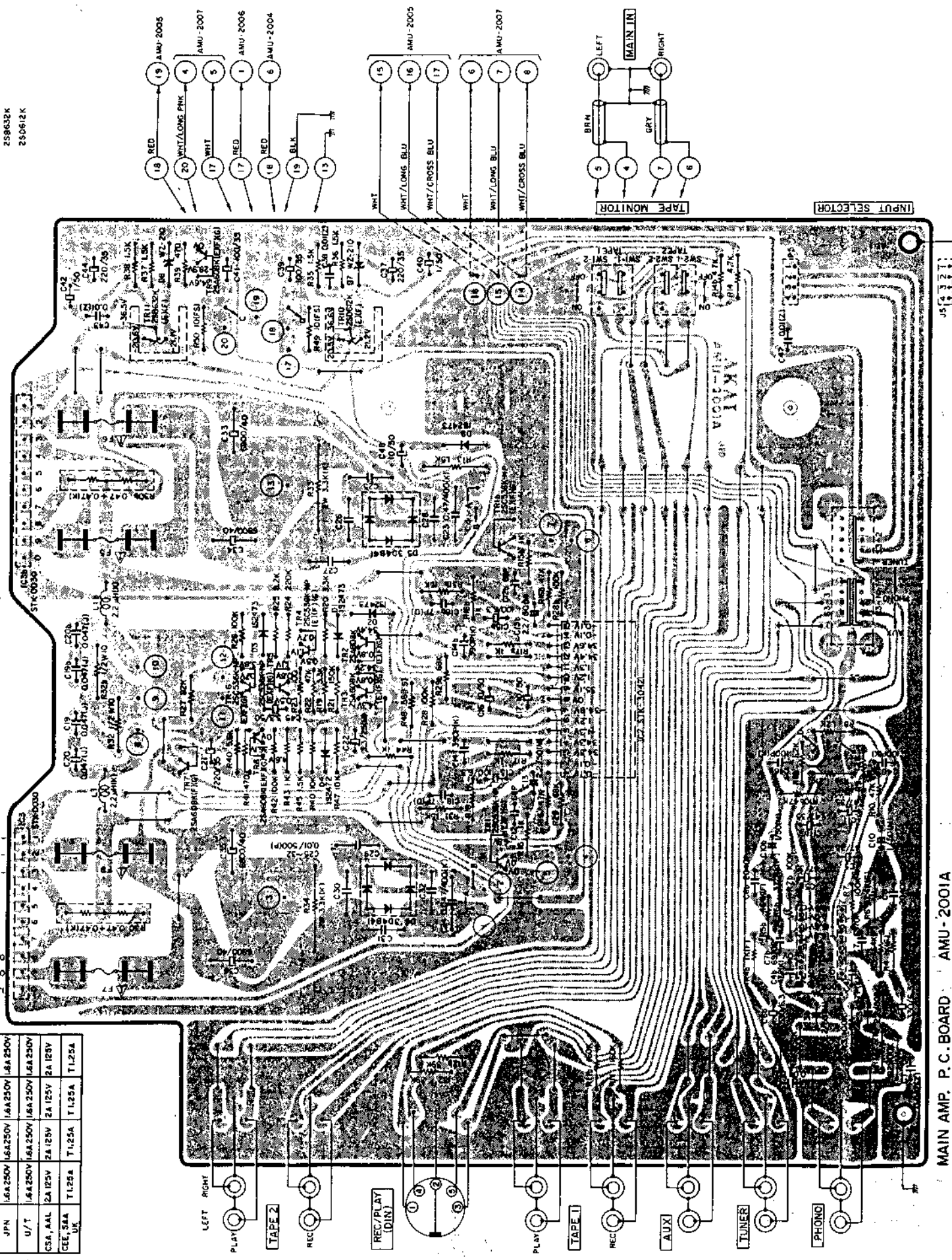

WARNING: INDICATES SAFETY CRITICAL COMPONENTS. FOR CONTINUED SAFETY, REPLACE SAFETY CRITICAL COMPONENTS ONLY WITH MANUFACTURER'S RECOMMENDED PARTS  
 AVERTISSEMENT: IL INDIQUE LES COMPOSANTS CRITIQUES DE SURETE. POUR MAINTENIR LE DEGRE DE SECURITE DE L'APPAREIL, NE REMPLACER LES COMPOSANTS DONT LE FONCTIONNEMENT EST CRITIQUE POUR LA SECURITE QUE PAR DES PIECES RECOMMANDEES PAR LE FABRICANT

Bar Meter Driving P.C Board AMU-2004

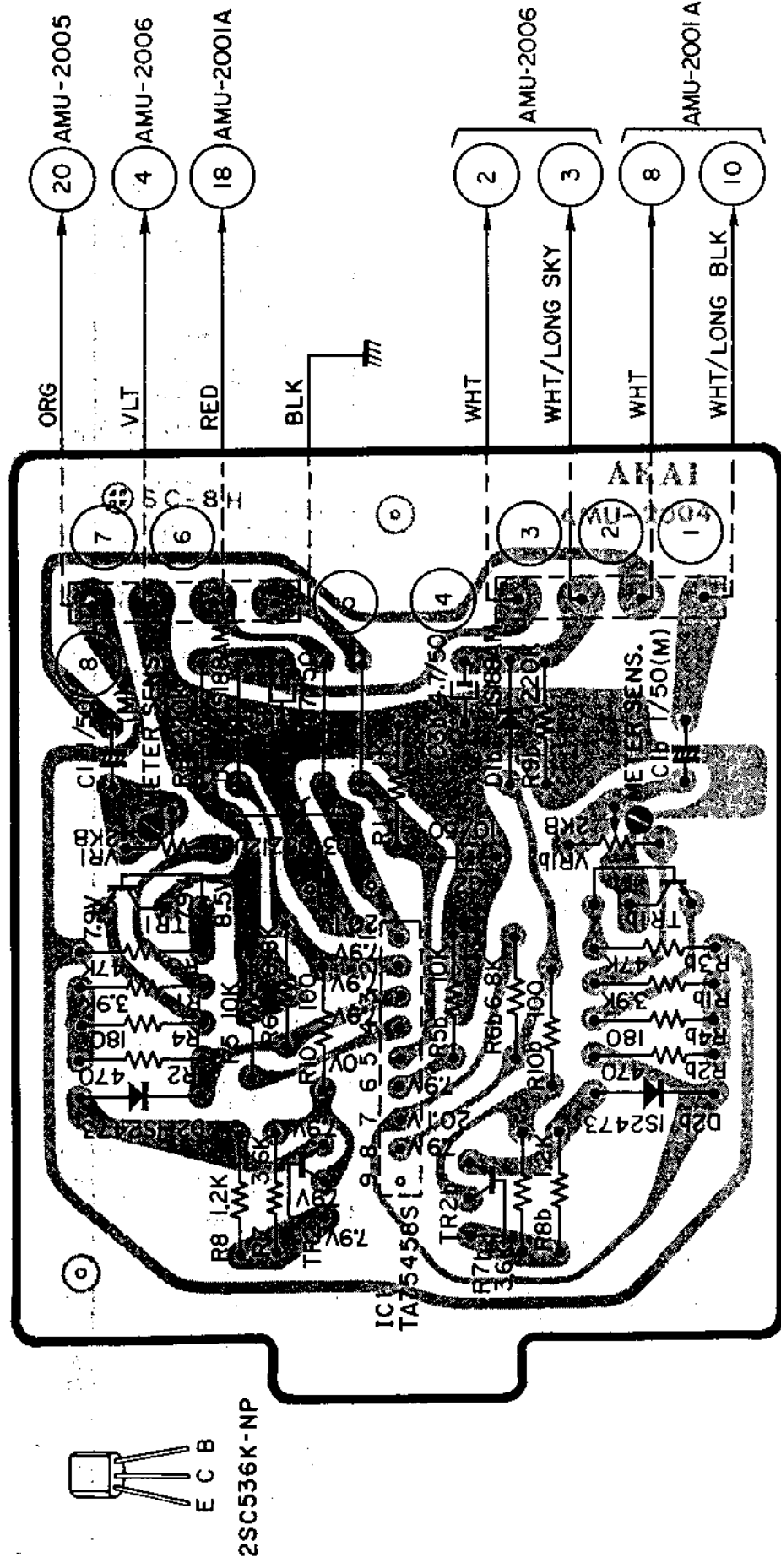

BAR METER DRIVING P.C BOARD  
 AMU-2004

TR1, TR2, TR1b, TR2b  
 2SC536K-NP (EXF)(G)

Bar Meter P.C Board AMU-2006

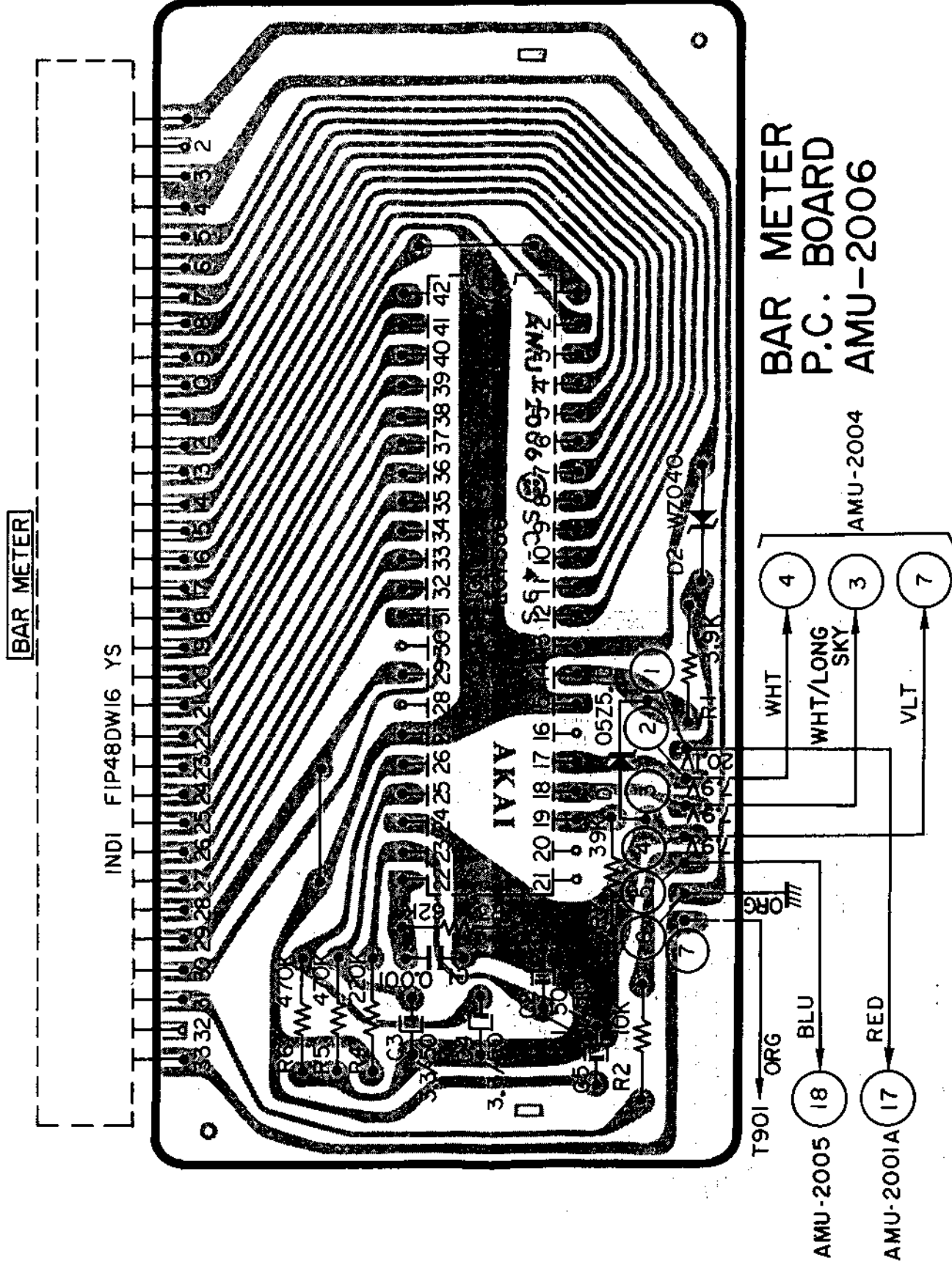

BAR METER  
 P.C. BOARD  
 AMU-2006



Push Switch P.C Board AMU-2005

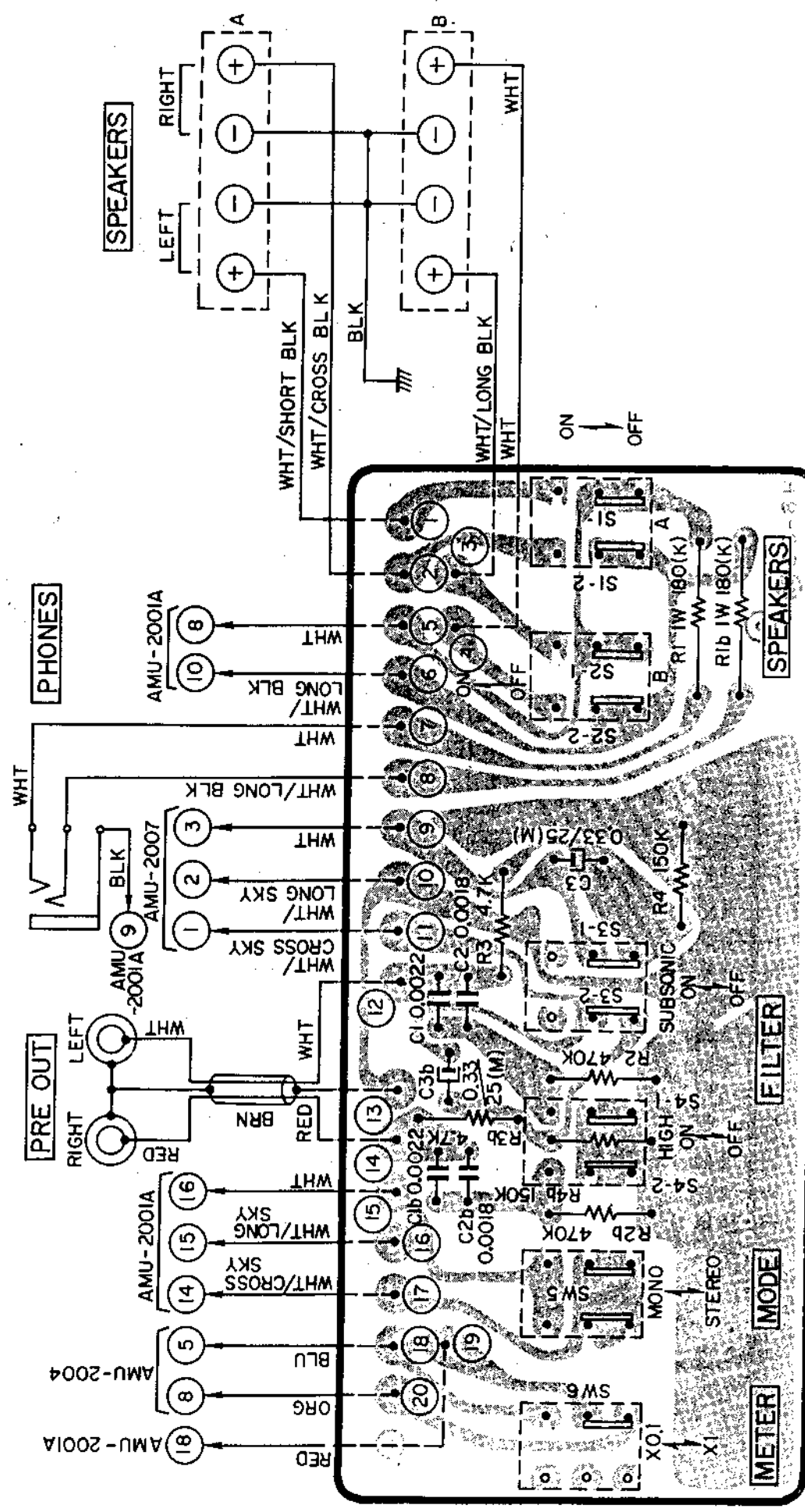

PUSH SWITCH P.C BOARD  
AMU-2005

Loudness P.C Board AMU-2003 and Control P.C Board AMU-2007

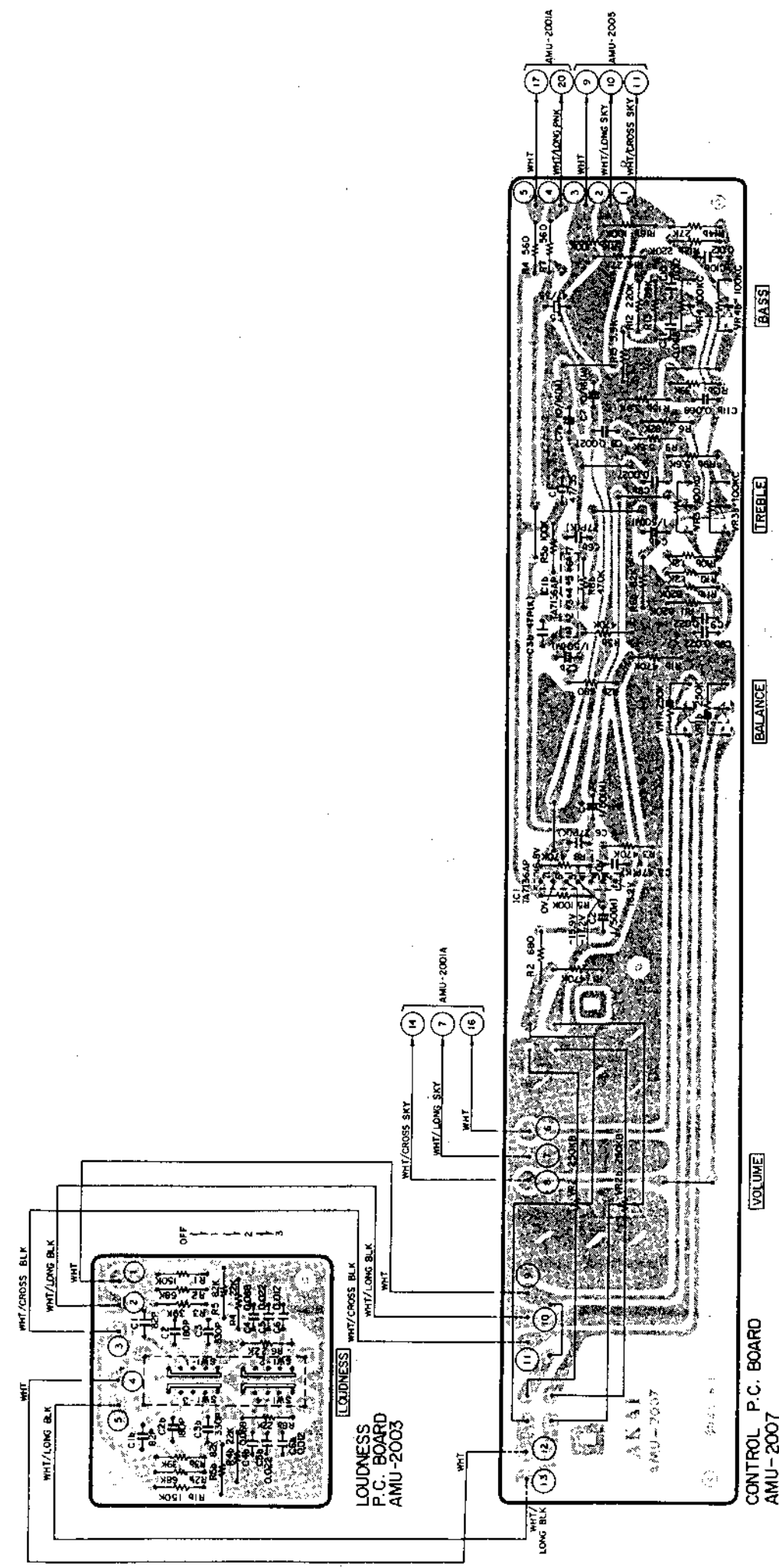

CONTROL P.C. BOARD  
AMU-2007