

AKAI SERVICE MANUAL

AM-U04

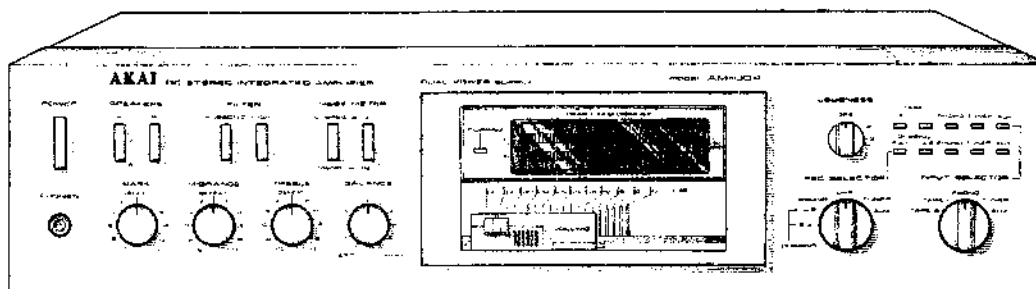

STEREO INTEGRATED AMPLIFIER

MODEL **AM-U04**

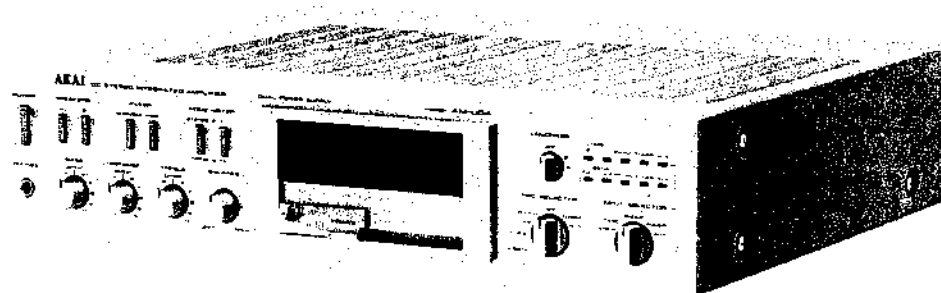

STEREO INTEGRATED AMPLIFIER

MODEL **AM- U04**

ALSO APPLICABLE TO BLACK PANEL MODEL

SECTION 1	SERVICE MANUAL	3
SECTION 2	PARTS LIST	23
SECTION 3	SCHEMATIC DIAGRAM	34

SECTION 1

SERVICE MANUAL

TABLE OF CONTENTS

I. TECHNICAL DATA	4
II. DISMANTLING OF UNIT	5
III. CONTROLS	6
IV. PRINCIPAL PARTS LOCATION	7
V. VOLTAGE CONVERSION	8
VI. LEVEL DIAGRAM	9
VII. AMPLIFIER ADJUSTMENT	10
1. CENTER OFF-SET VOLTAGE ADJUSTMENT	10
2. BAR METER SENSITIVITY ADJUSTMENT	10
VIII. CLASSIFICATION OF VARIOUS P.C BOARDS	11
1. P.C BOARD TITLES AND IDENTIFICATION NUMBERS	11
2. COMPOSITION OF VARIOUS P.C BOARDS	12

For basic adjustments, measuring methods, and operating principles, refer to GENERAL TECHNICAL MANUAL.

I. TECHNICAL DATA

POWER AMPLIFIER SECTION

RATED POWER OUTPUT 2-CHANNELS DRIVEN	48 watts per channel, minimum RMS. at 8 ohms from 20 to 20,000 Hz with no more than 0.008% total harmonic distortion.
POWER BANDWIDTH (IHF)	6 Hz to 60 kHz/8 ohms (Total Harmonic distortion 0.05%)
SIGNAL TO NOISE RATIO (IHF)	PHONO AUX
	Better than 82 dB Better than 95 dB
RESIDUAL NOISE	Less than 0.5 mV at 8 ohms
CHANNEL SEPARATION (IHF)	PHONO
	Better than 60 dB at 1,000 Hz
DAMPING FACTOR	More than 140 (1 kHz, 8 ohms)
OUTPUT EXPIRED LOAD IMPEDANCE SPEAKERS	A, B (4 to 16 ohms)/A+B (8 to 16 ohms)

PREAMPLIFIER SECTION

INPUT SENSITIVITY/IMPEDANCE	PHONO AUX TUNER TAPE MONITOR	3 mV/47 kohms 150 mV/100 kohms 150 mV/100 kohms PIN: 150 mV/100 kohms DIN: 150 mV/100 kohms
OUTPUT LEVEL/IMPEDANCE	TAPE REC PRE OUTPUT	PIN: 150 mV/1 kohms DIN: 30 mV/30 kohms 1 mV/1 kohms
FREQUENCY RESPONSE	PHONO (RIAA EQUALIZATION) TUNER, AUX, TAPE MONITOR	30 Hz to 15 kHz +0.2 dB, -0.2 dB 6 Hz to 100 kHz +0 dB, -0.2 dB
TONE CONTROL	BASS MIDRANGE TREBLE	±8 dB at 100 Hz ±6 dB at 1 kHz ±8 dB at 10 kHz
LOUDNESS CONTROL		at 100 Hz at 10 kHz 1. 3 dB 1. 2.5 dB 2. 6 dB 2. 5 dB 3. 9 dB 3. 8 dB (Volume control set at -30 dB position)
FILTER	HIGH LOW	-3 dB at 10 kHz -3 dB at 18 Hz

MISCELLANEOUS

POWER REQUIREMENTS	100 V, 50/60 Hz for Japan 120 V, 60 Hz for USA and Canada 220 V, 50 Hz for Europe except UK 240 V, 50 Hz for UK and Australia 110 V/220 V/240 V, 50/60 Hz internally switchable for others.
POWER CONSUMPTION	U/T 210 W AAL 150 W CSA 250 W CEE 340 W JPN 375 W UK, SAA 380 W
DIMENSIONS	440 (W) × 105 (H) × 308 (D) mm (17.3 × 4.1 × 12.1 inches)
WEIGHT	10.1 kg (22.2 lbs)

* For improvement purposes, specifications and design are subject to change without notice.

II. DISMANTLING OF UNIT

In case of trouble, etc. necessitating dismantling, please dismantle in the order shown in the Photographs. Reassemble in reverse order.

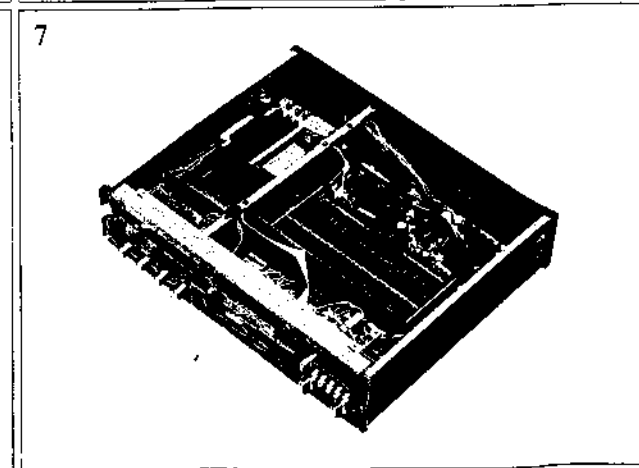
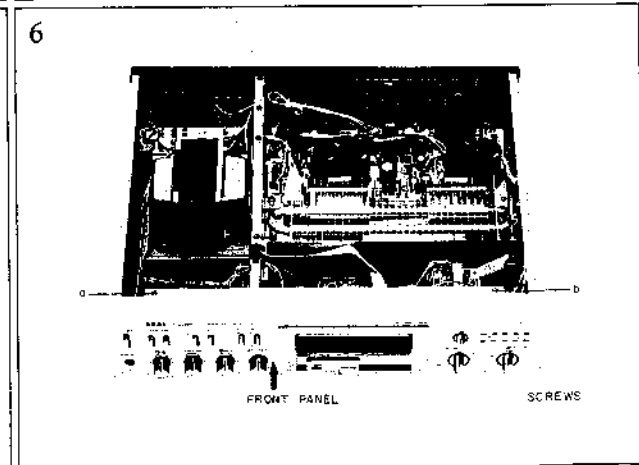
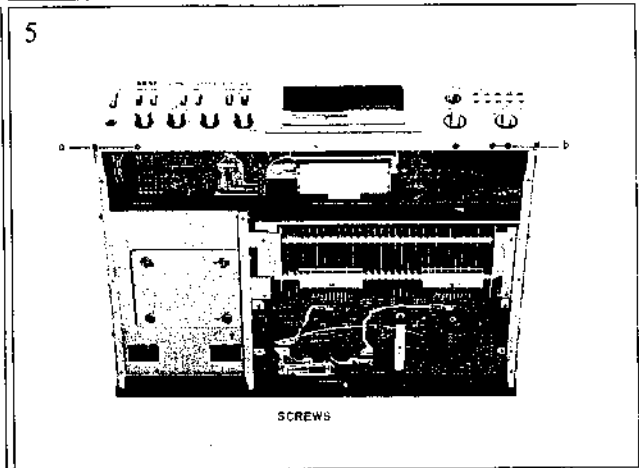
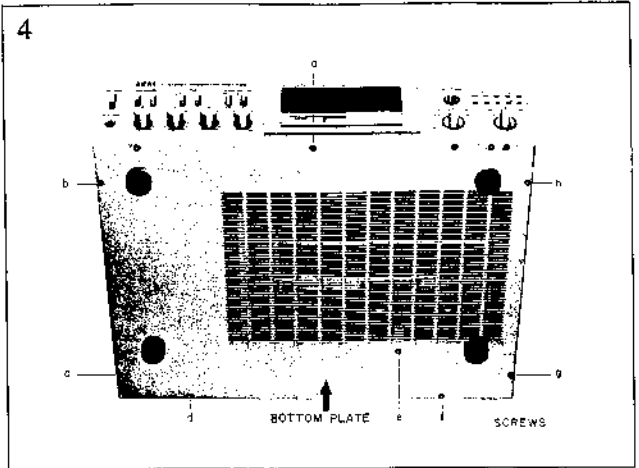
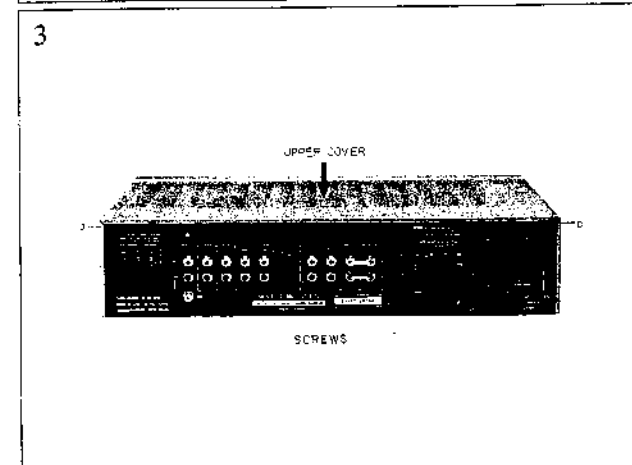
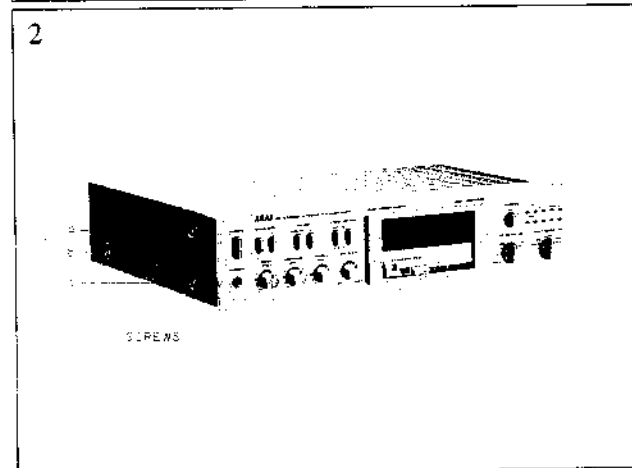
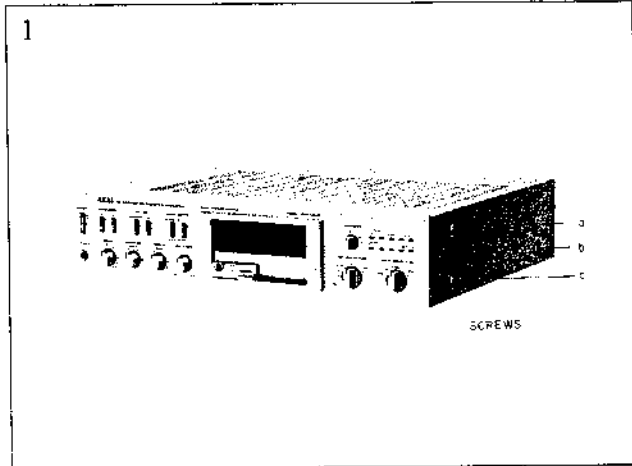

III. CONTROLS

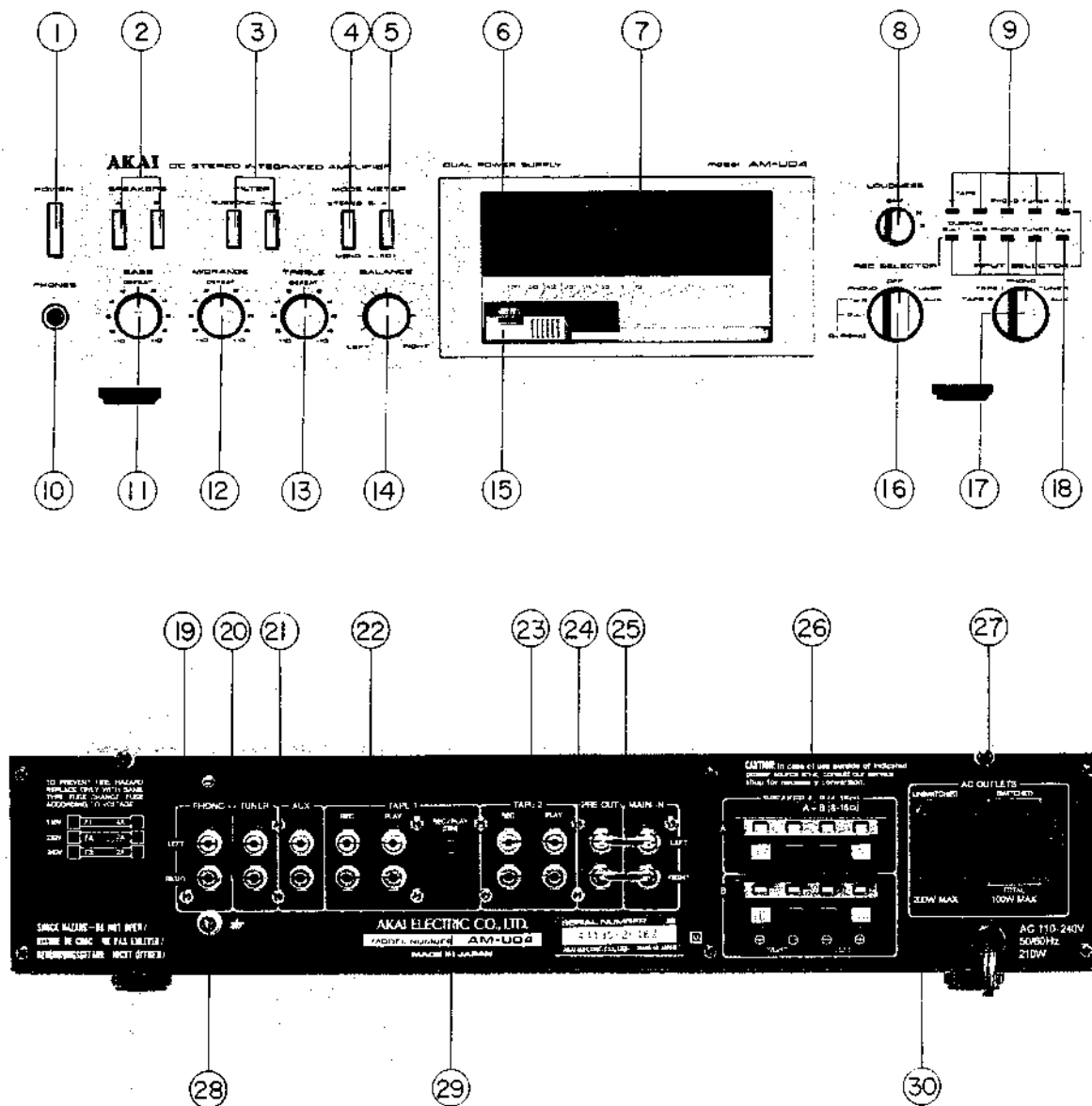

Fig. 1 Controls

- | | |
|--|--|
| <ol style="list-style-type: none"> 1. POWER SWITCH 2. SPEAKER SYSTEM SELECTOR SWITCHES 3. FILTER SWITCHES 4. MODE SELECTOR 5. METER SWITCH 6. CLIPPING INDICATOR 7. FLD BAR METER 8. LOUDNESS SWITCH 9. INPUT SELECTOR INDICATOR 10. HEADPHONE JACK 11. BASS CONTROL 12. MIDRANGE TONE CONTROL 13. TREBLE CONTROL 14. STEREO BALANCE CONTROL 15. VOLUME CONTROL 16. RECORDING SELECTOR 17. INPUT SELECTOR | <ol style="list-style-type: none"> 18. RECORDING SELECTOR INDICATOR 19. PHONO TERMINALS 20. TUNER TERMINALS 21. AUX TERMINALS 22. TAPE 1 SYSTEM REC/PLAY TERMINALS 23. TAPE 2 SYSTEM REC/PLAY TERMINALS 24. PRE-OUT TERMINALS 25. MAIN-IN TERMINALS 26. A AND B SYSTEM SPEAKER TERMINALS 27. EXTRA AC OUTLETS (Some models are not equipped with this facility.) 28. GROUND TERMINAL 29. TAPE 1 SYSTEM DIN JACK (Some models do not have this facility.) 30. AC CORD (Some models are equipped with an AC Inlet instead of an AC cord. Connect with an appropriate power cord.) |
|--|--|

IV. PRINCIPAL PARTS LOCATION

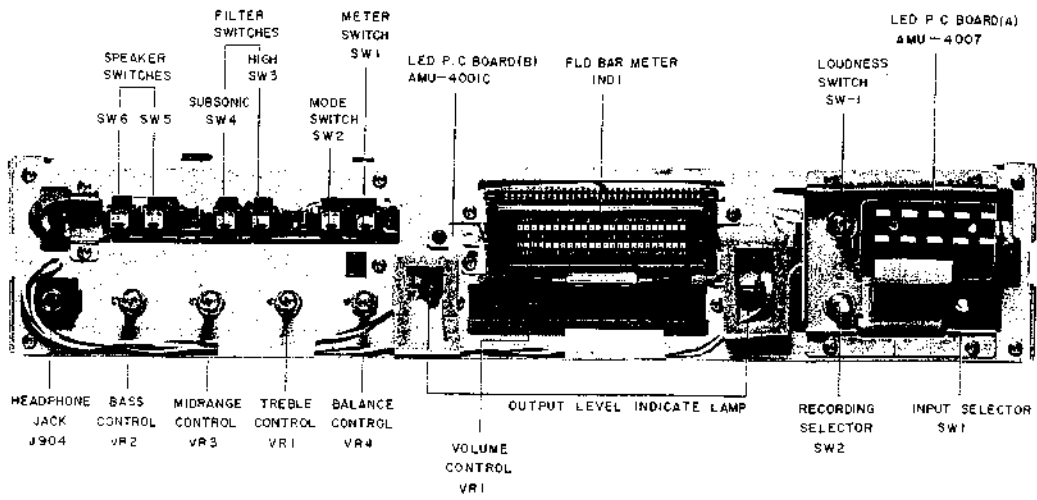

Fig. 2 Front View

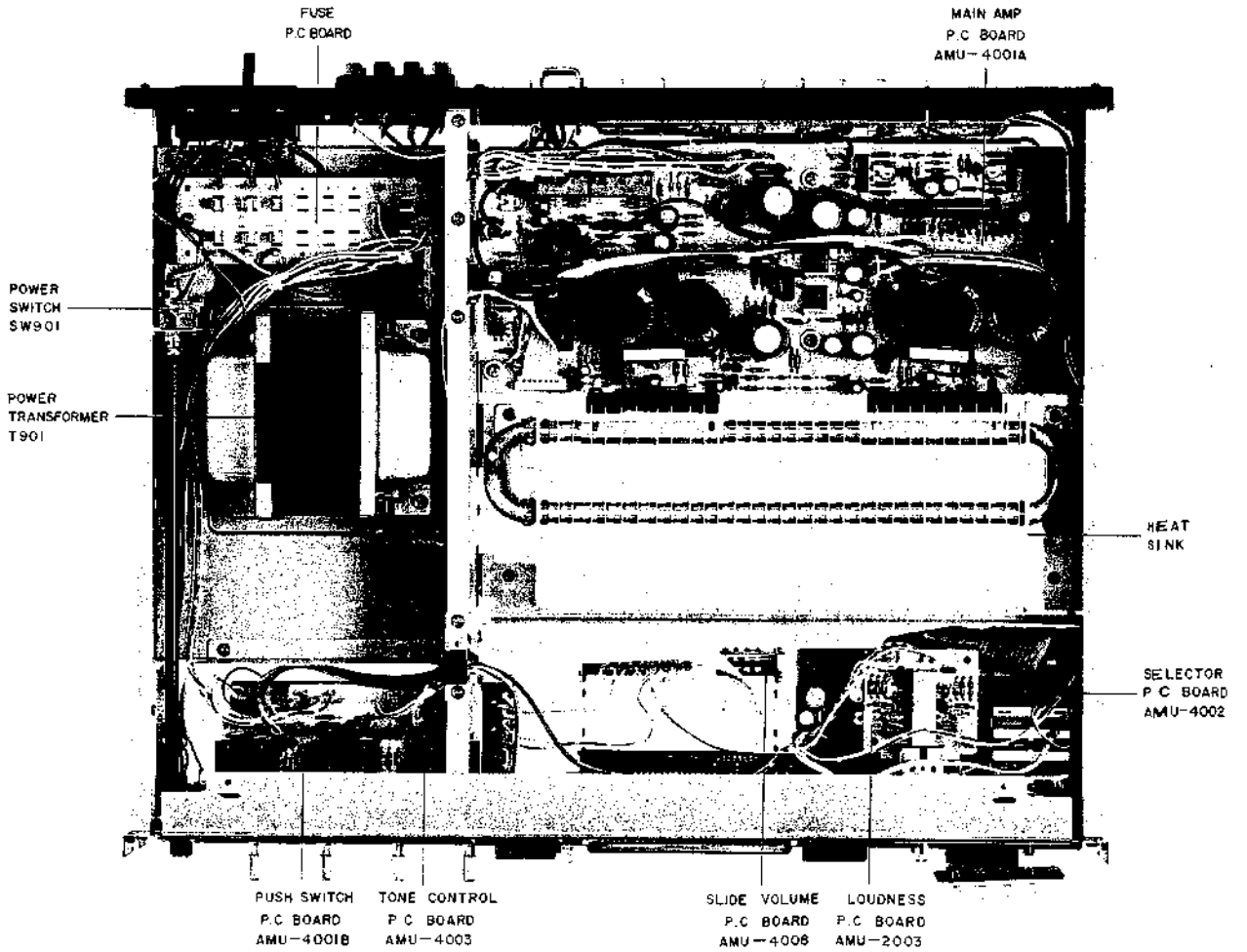

Fig. 3 Top View

V. VOLTAGE CONVERSION

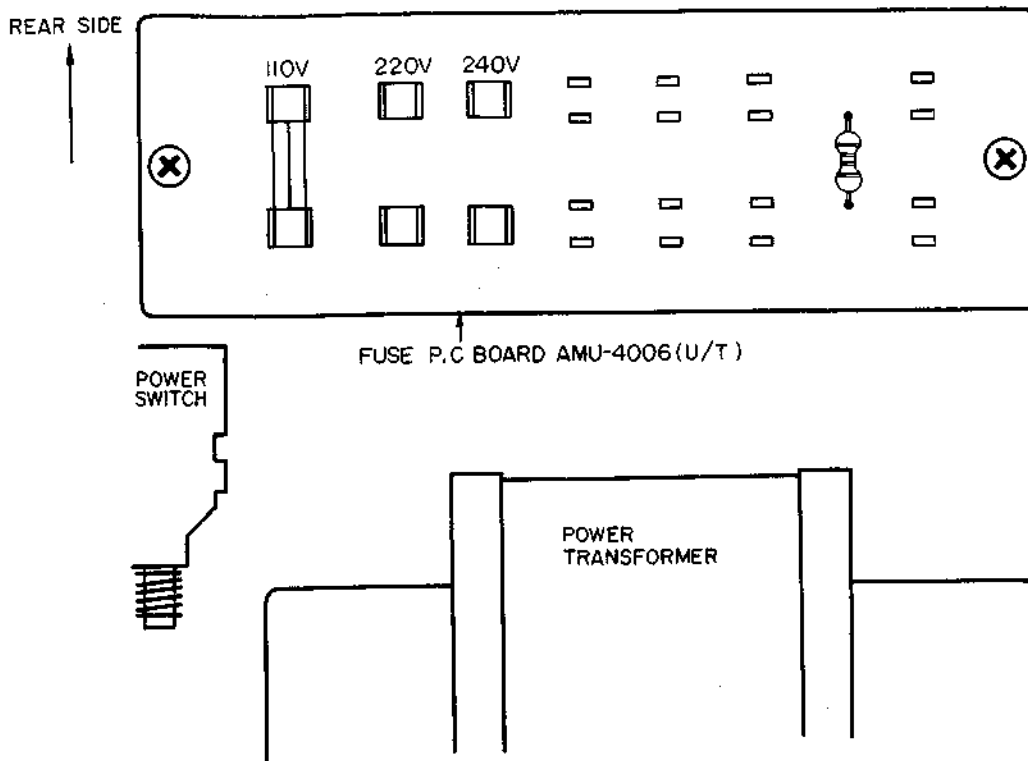

Fig. 4 Voltage Conversion (U/T Model)

Models for Canada, USA, Europe, UK, JPN and Australia are not equipped with this facility.

Each machine is preset at the factory according to destination but some machines can be set to 110 V, 220 V or 240 V as required.

If voltage change is necessary, this can be accomplished as follows.

- 1) Disconnect AC Power Cord.
- 2) Loosen holding screws and remove upper cover.
- 3) Remove existing line voltage fuse and insert required line voltage fuse in proper fuse holder, explicitly following instructions printed on rear panel.

110 V AREA: 4 A

220 V AREA: 2 A

240 V AREA: 2 A

VI. LEVEL DIAGRAM

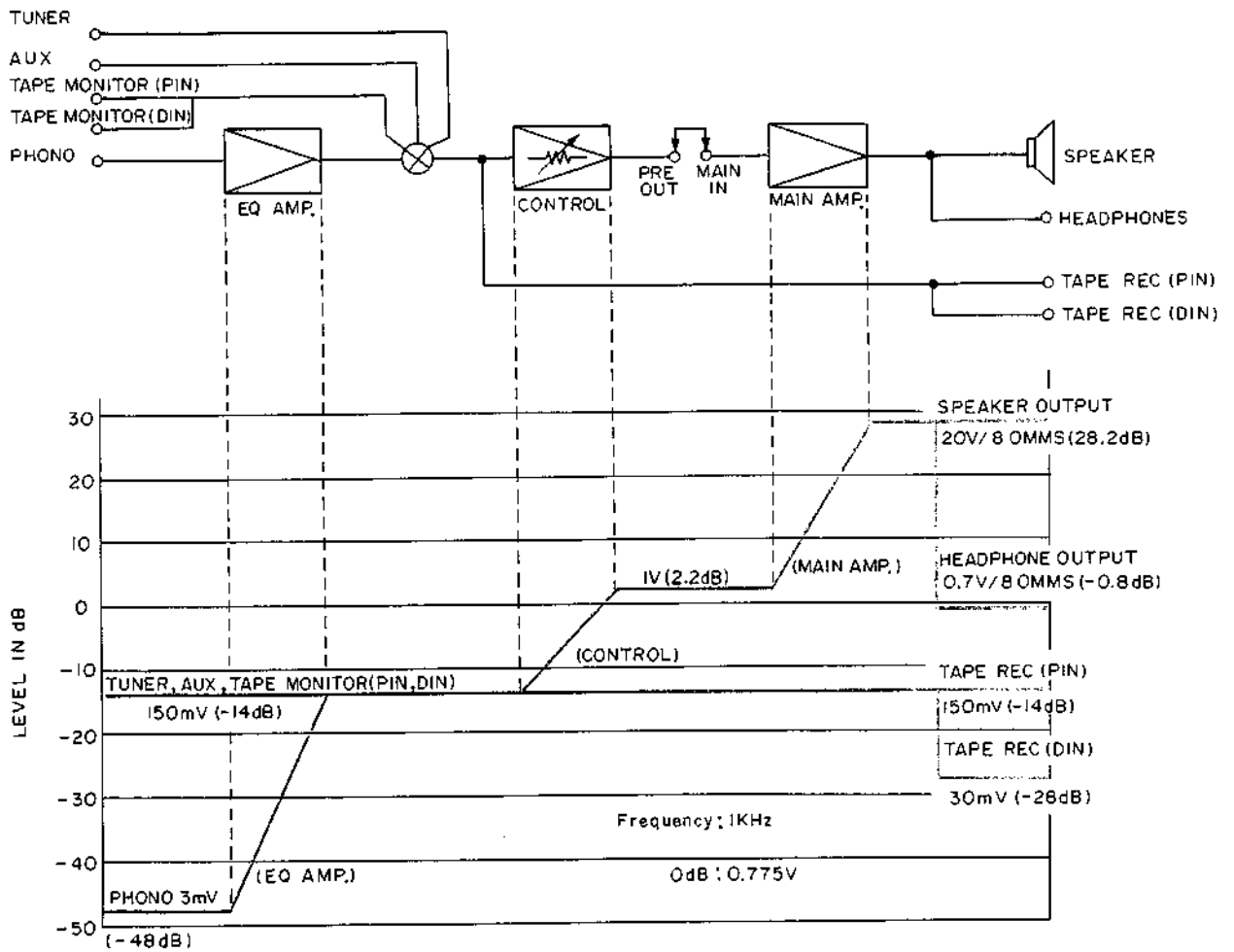

Fig. 5 Level Diagram

VII. AMPLIFIER ADJUSTMENT

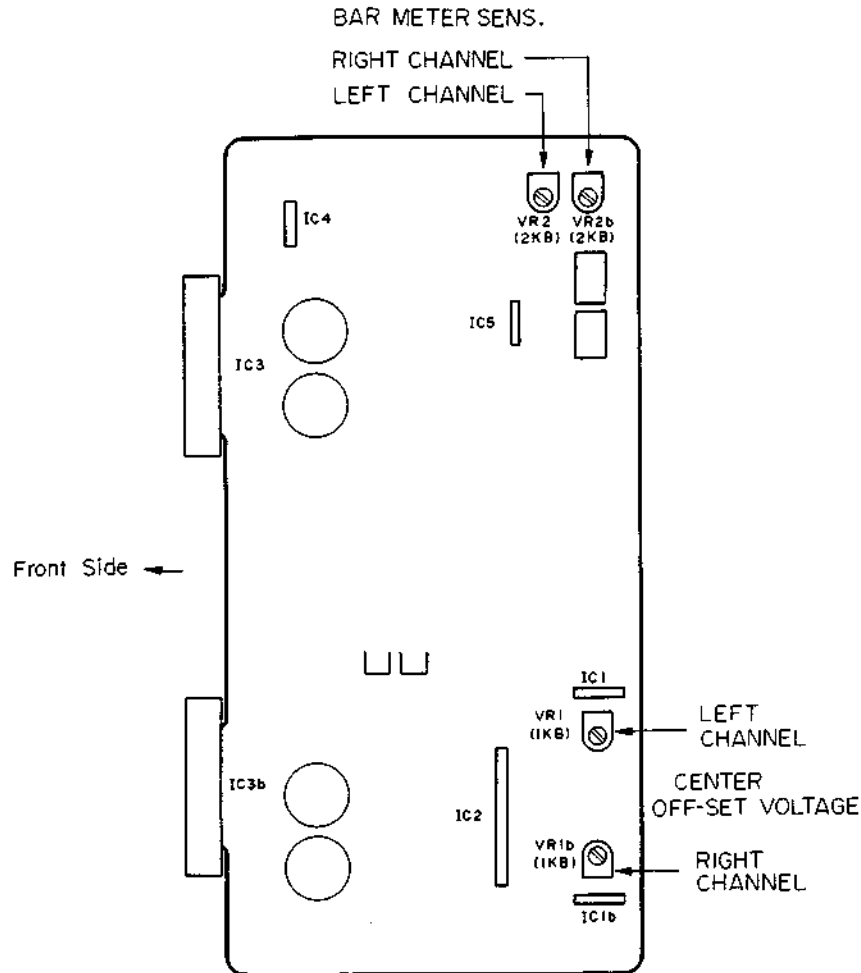

Fig. 6 Main Amp. P.C Board AMU-4001A

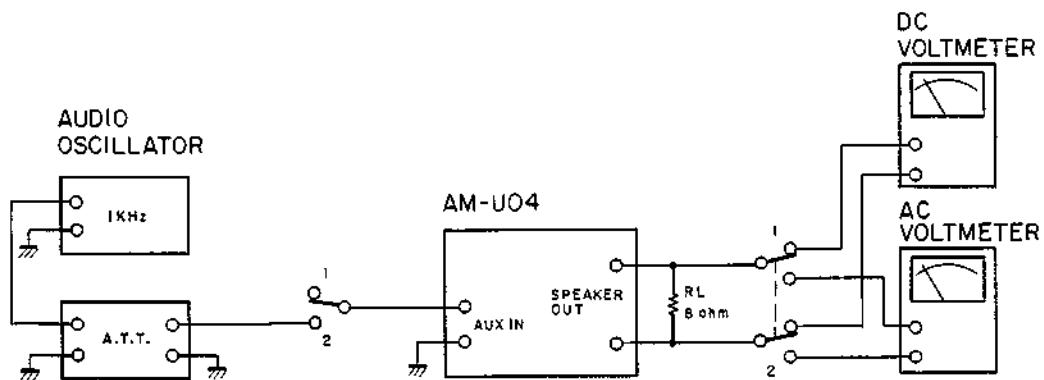

Fig. 7 Instrument Connections

1. CENTER OFF-SET VOLTAGE

ADJUSTMENT (Refer to Figs. 5, 6)

Connect the Digital Voltmeter or DC Voltmeter to the Speaker terminal. Adjust the VR 1 (1 KB) on the Main Amp. P.C Board, so that the Voltmeter reading is 0 ± 10 mV.

2. BAR METER SENSITIVITY ADJUSTMENT

(Refer to Figs. 5, 6)

The Meter Switch should be set to "x1". Connect a load resistor (RL: 8 ohms) to the Speaker terminal, and input 1 kHz through the AUX terminal. Adjust the VR 2 (2 KB) on the Main Amp. P.C Board until the voltage at both ends of the load resistor is 10.95 V (AC voltmeter) were the Power Meter indicate 15 watts.

VIII. CLASSIFICATION OF VARIOUS P.C BOARDS

1. P.C BOARD TITLES AND IDENTIFICATION NUMBERS

P.C Board Title	P.C Board Number
Main Amp P.C Board	AMU-4001A
Push Switch P.C Board	AMU-4001B
LED P.C Board (B)	AMU-4001C
Selector P.C Board	AMU-4002
Tone Control P.C Board	AMU-4003
Pin Jack P.C Board	AMU-4005
Fuse P.C Board (U/T)	AMU-4006
Fuse P.C Board (CSA, AAL)	AMU-4058
Fuse P.C Board (JPN)	AMU-4060
Fuse P.C Board (CEE, UK, SAA)	AMU-4059
LED P.C Board (A)	AMU-4007
Slide Volume P.C Board	AMU-4008
Loudness P.C Board	AMU-2003
Bar Meter P.C Board	AMU-2006

Chart-1

2. COMPOSITION OF VARIOUS P.C BOARDS

1) MAIN AMP P.C BOARD AMU-4001A (3ED) and LED P.C BOARD (B) AMU-4001C

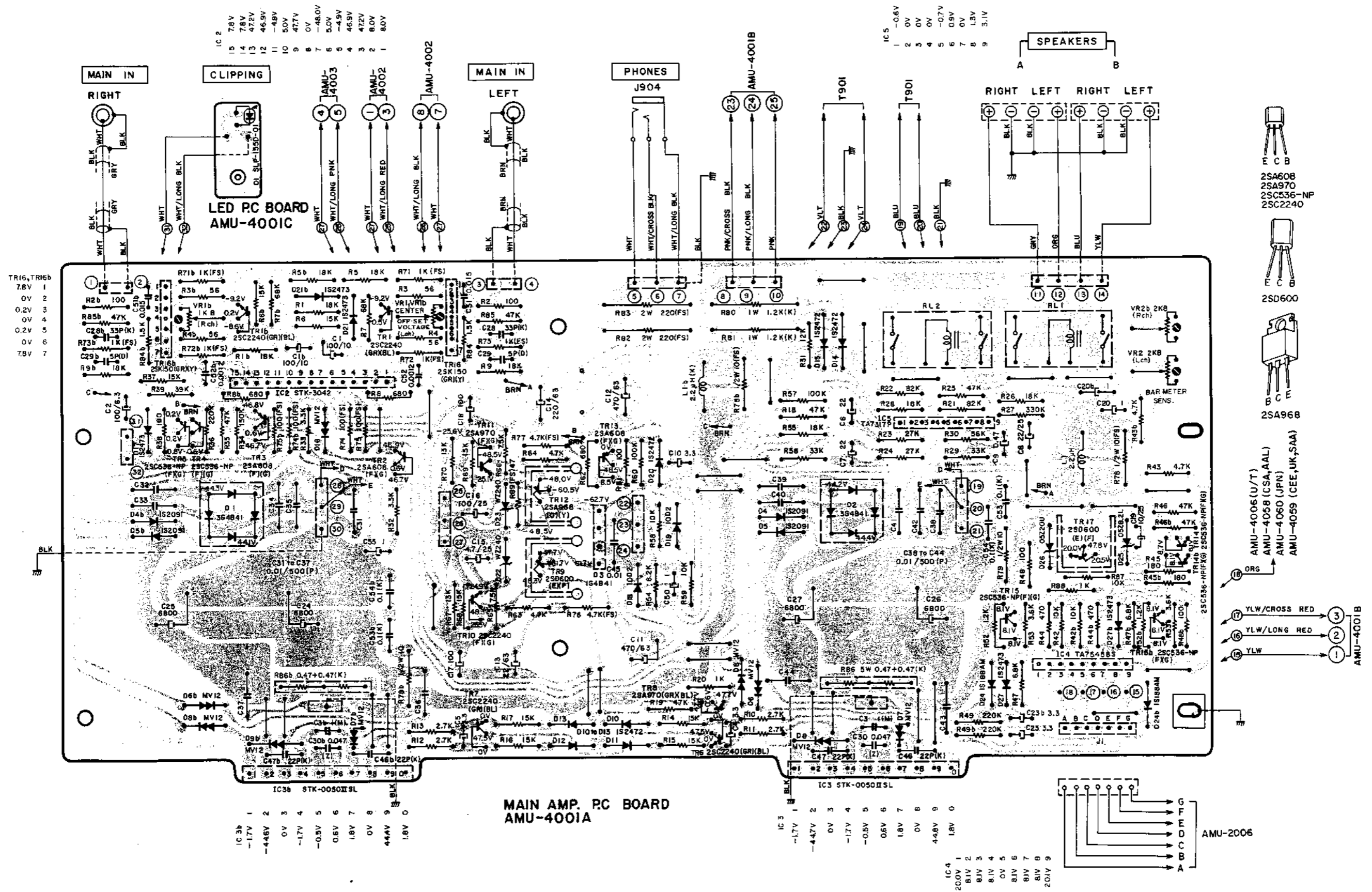

VIII. CLASSIFICATION OF VARIOUS P.C BOARDS

I. P.C BOARD TITLES AND IDENTIFICATION NUMBERS

P.C Board Title	P.C Board Number
Main Amp P.C Board	AMU-4001A
Push Switch P.C Board	AMU-4001B
LED P.C Board (B)	AMU-4001C
Selector P.C Board	AMU-4002
Tone Control P.C Board	AMU-4003
Pin Jack P.C Board	AMU-4005
Fuse P.C Board (U/T)	AMU-4006
Fuse P.C Board (CSA, AAL)	AMU-4058
Fuse P.C Board (JPN)	AMU-4060
Fuse P.C Board (CEE, UK, SAA)	AMU-4059
LED P.C Board (A)	AMU-4007
Slide Volume P.C Board	AMU-4008
Loudness P.C Board	AMU-2003
Bar Meter P.C Board	AMU-2006

Chart-1

2) PUSH SWITCH P.C BOARD AMU-4001B

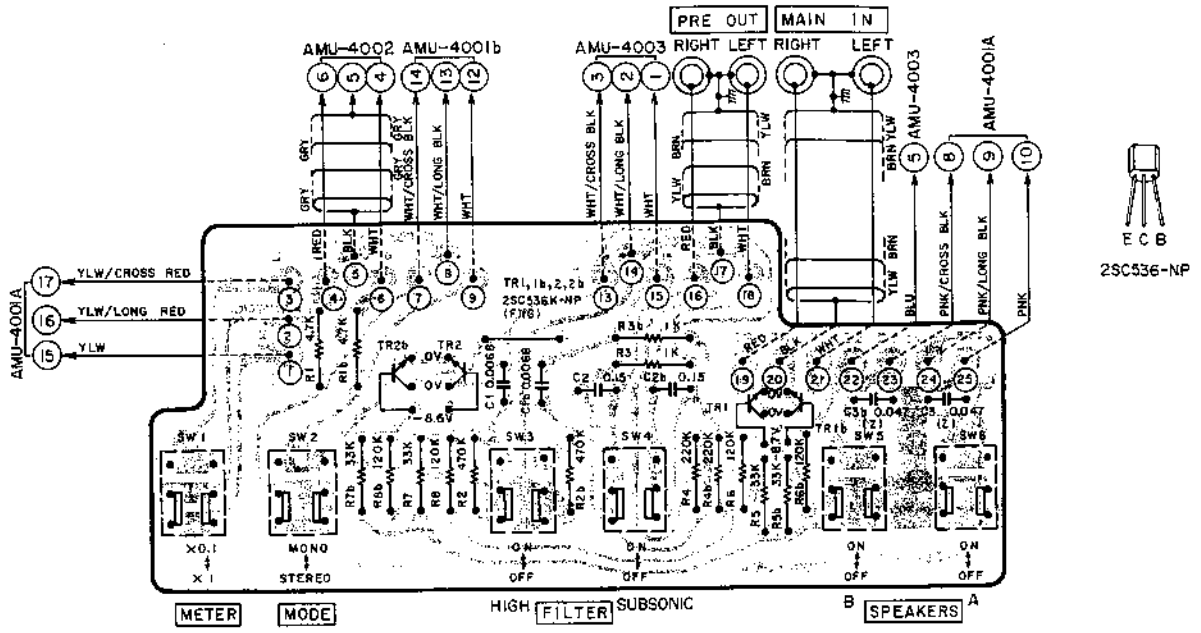

3) SELECTOR P.C BOARD AMU-4002

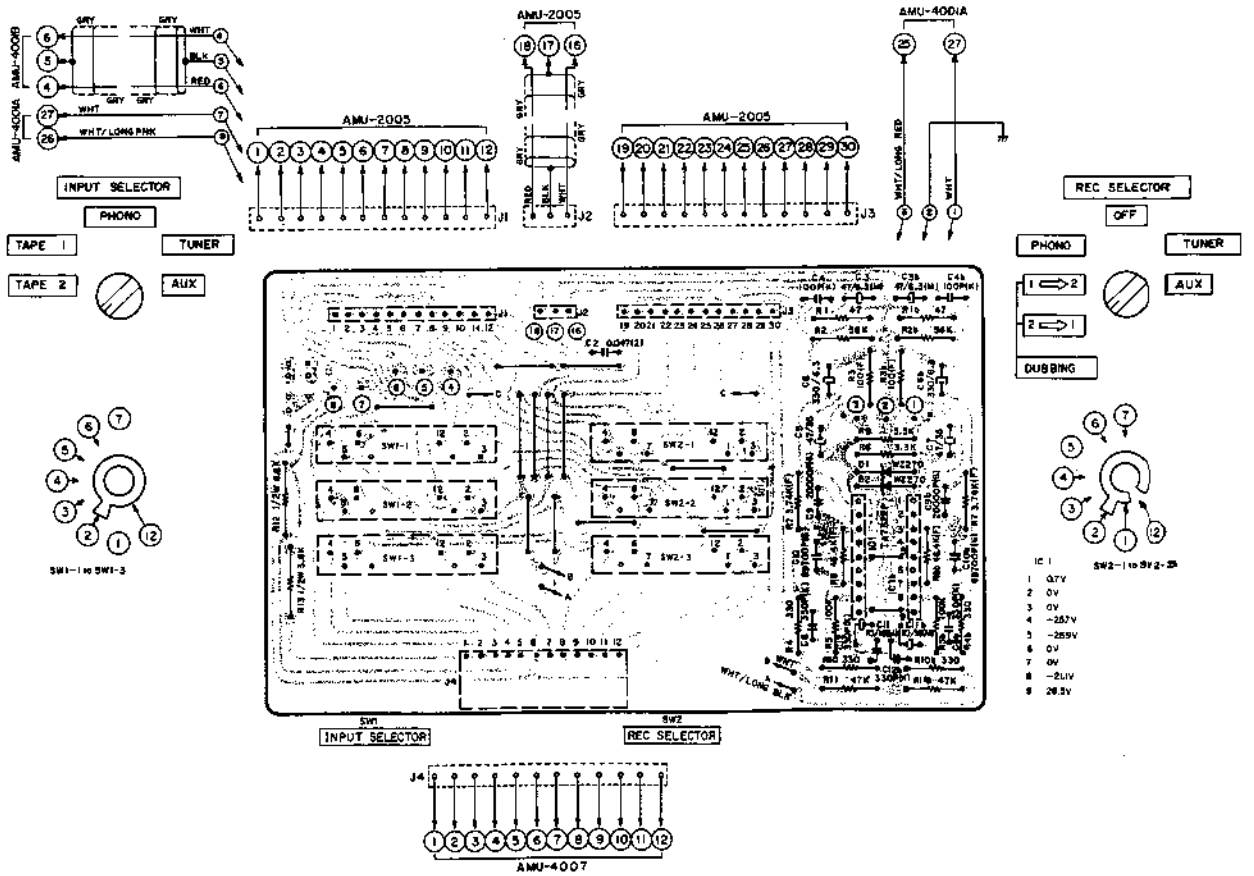

4) TONE CONTROL P.C BOARD AMU-4003

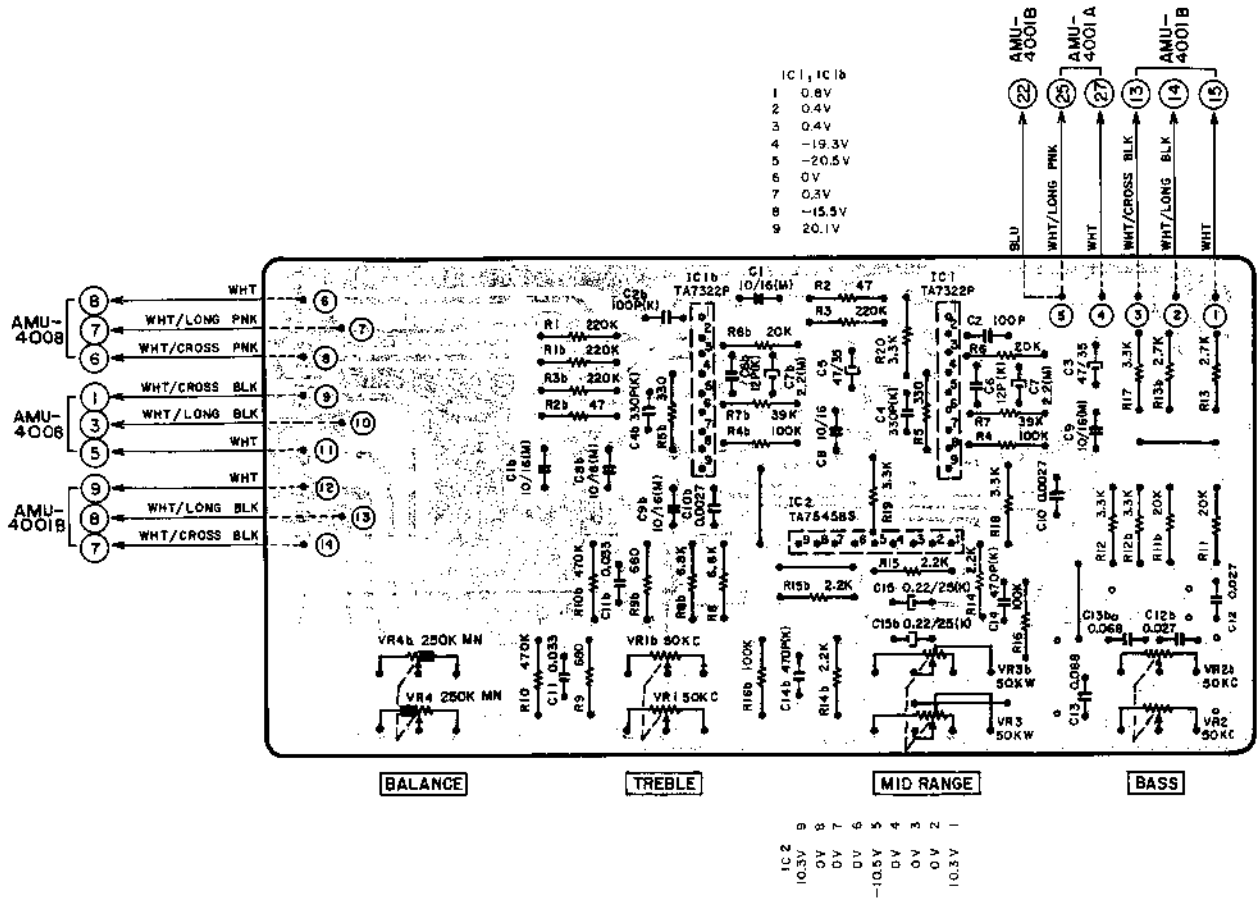

5) PIN JACK P.C BOARD AMU-4005

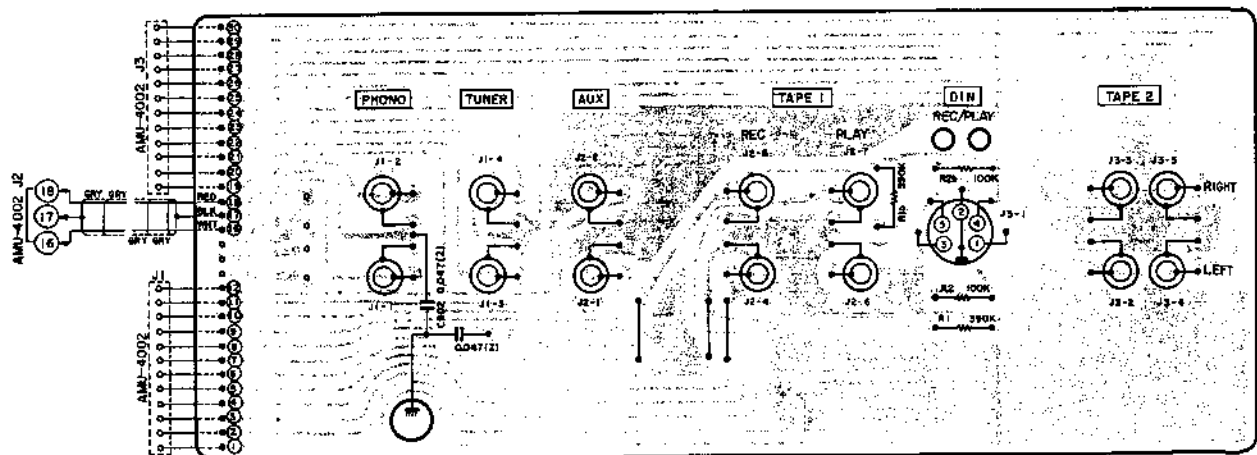

6) LED P.C BOARD AMU-4007

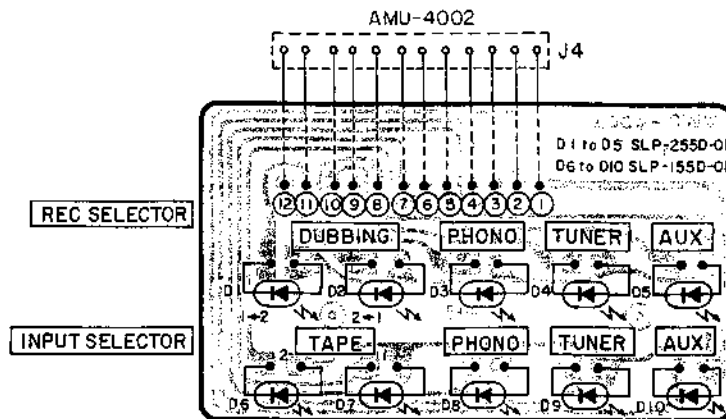

7) SLIDE VOLUME P.C BOARD AMU-4008

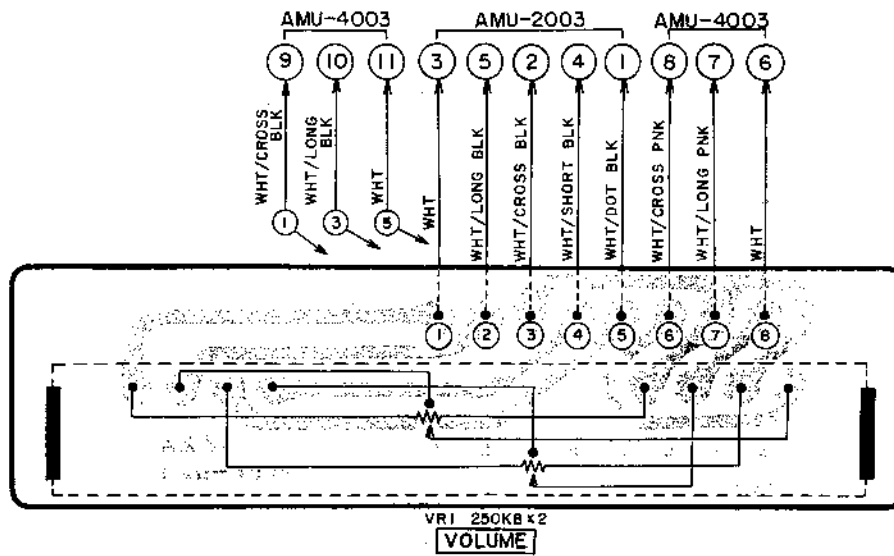

8) LOUDNESS P.C BOARD AMU-2003

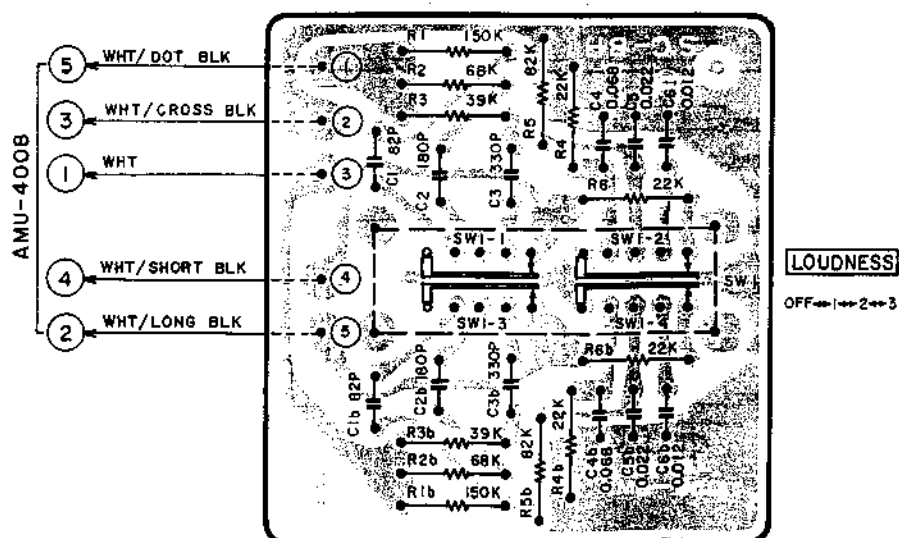

9) BAR METER P.C BOARD AMU-2006

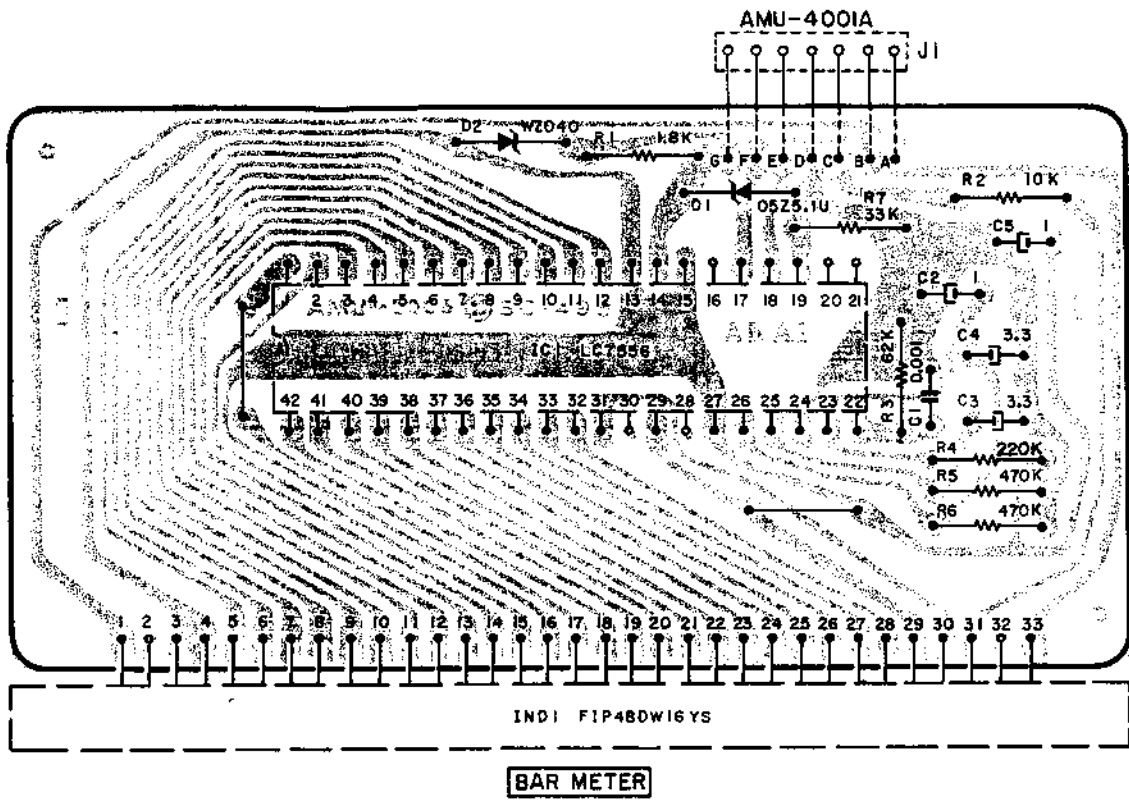

10) FUSE P.C BOARD AMU-4006 (U/T)

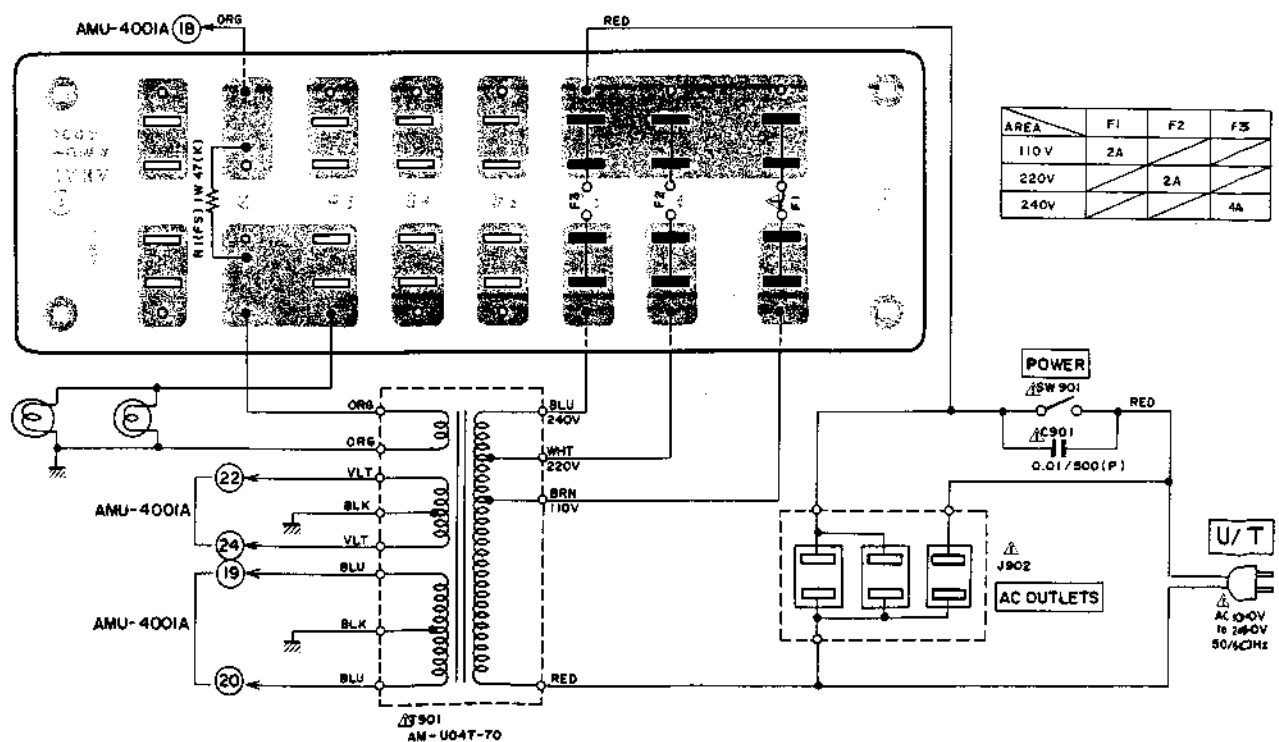

WARNING: INDICATES SAFETY CRITICAL COMPONENTS FOR CONTINUED SAFE USE. REPLACE SAFETY CRITICAL COMPONENTS ONLY WITH MANUFACTURER'S RECOMMENDED PARTS.
 AVERTISSEMENT: ILL INDIQUE LES COMPOSANTS CRITIQUES DE SURETE. POUR MAINTENIR LE NIVEAU DE SECURITE DE L'APPAREIL, NE REMPLACEZ LES COMPOSANTS QU'AVEC LE FONCTIONNEMENT IBI. CONTINUER POUR LES COMPOSANTS RECOMMENDES PAR LE FABRICANT.

11) FUSE P.C BOARD AMU-4058 (CSA, AAL)

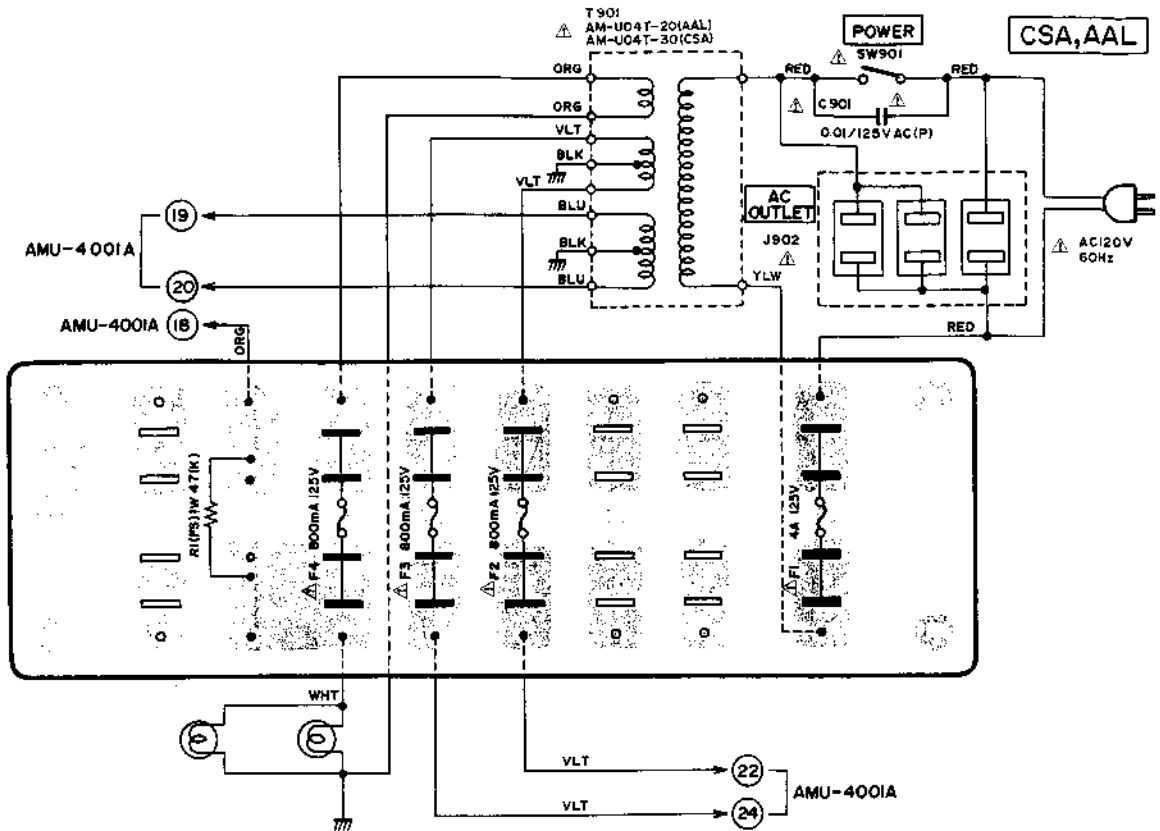

12) FUSE P.C BOARD AMU-4060 (JPN)

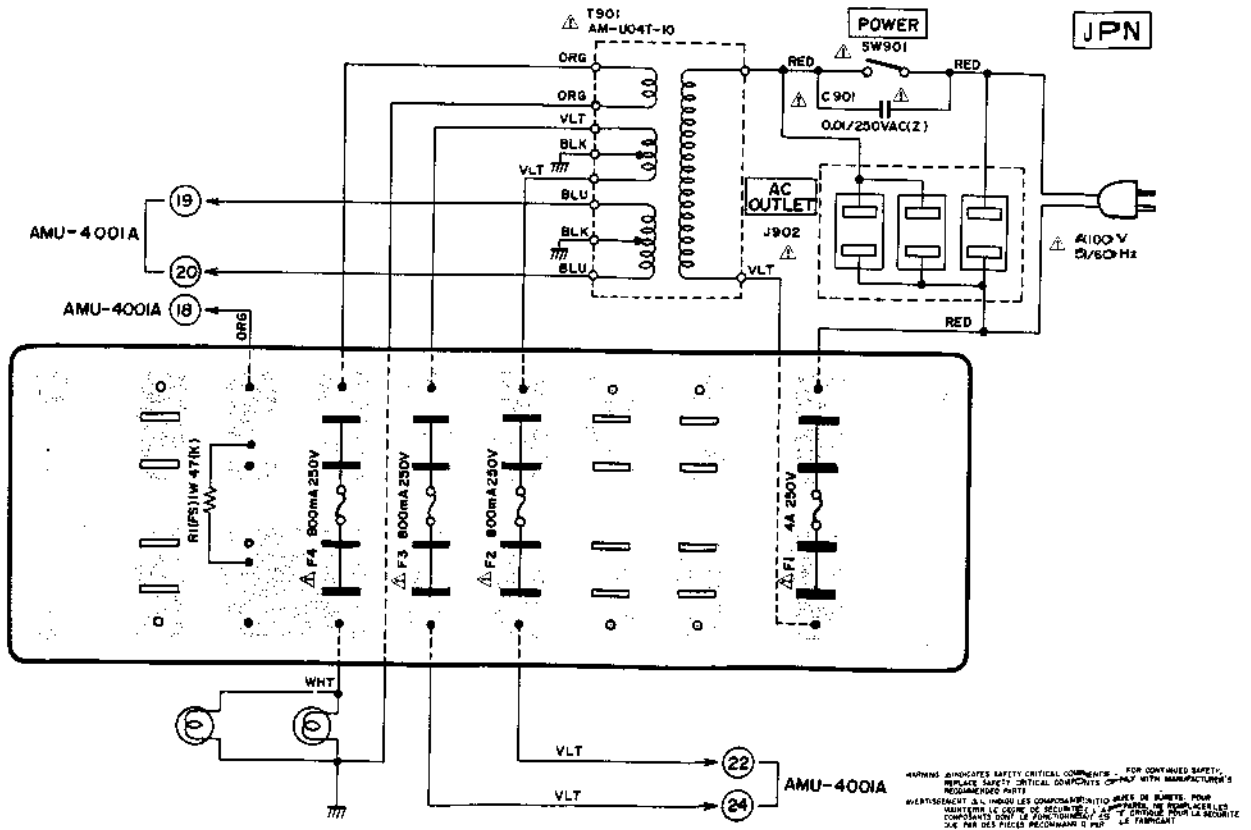

WARNING: INDICATES SAFETY CRITICAL COMPONENTS. FOR CONTINUED SAFETY, REPLACE SAFETY CRITICAL COMPONENTS ONLY WITH MANUFACTURER'S RECOMMENDED PARTS.
 AVERTISSEMENT: IL Y A DES COMPOSANTS CRITIQUES DE SÉCURITÉ. POUR MAINTENIR LE COÛT DE RÉPARATION À UN NIVEAU MINIMUM, REMPLACEZ SEULEMENT LES COMPOSANTS CRITIQUES DE SÉCURITÉ PAR DES PIÈCES RECOMMANDÉES PAR LE FABRICANT.

13) FUSE P.C BOARD AMU-4059 (CEE, UK, SAA)

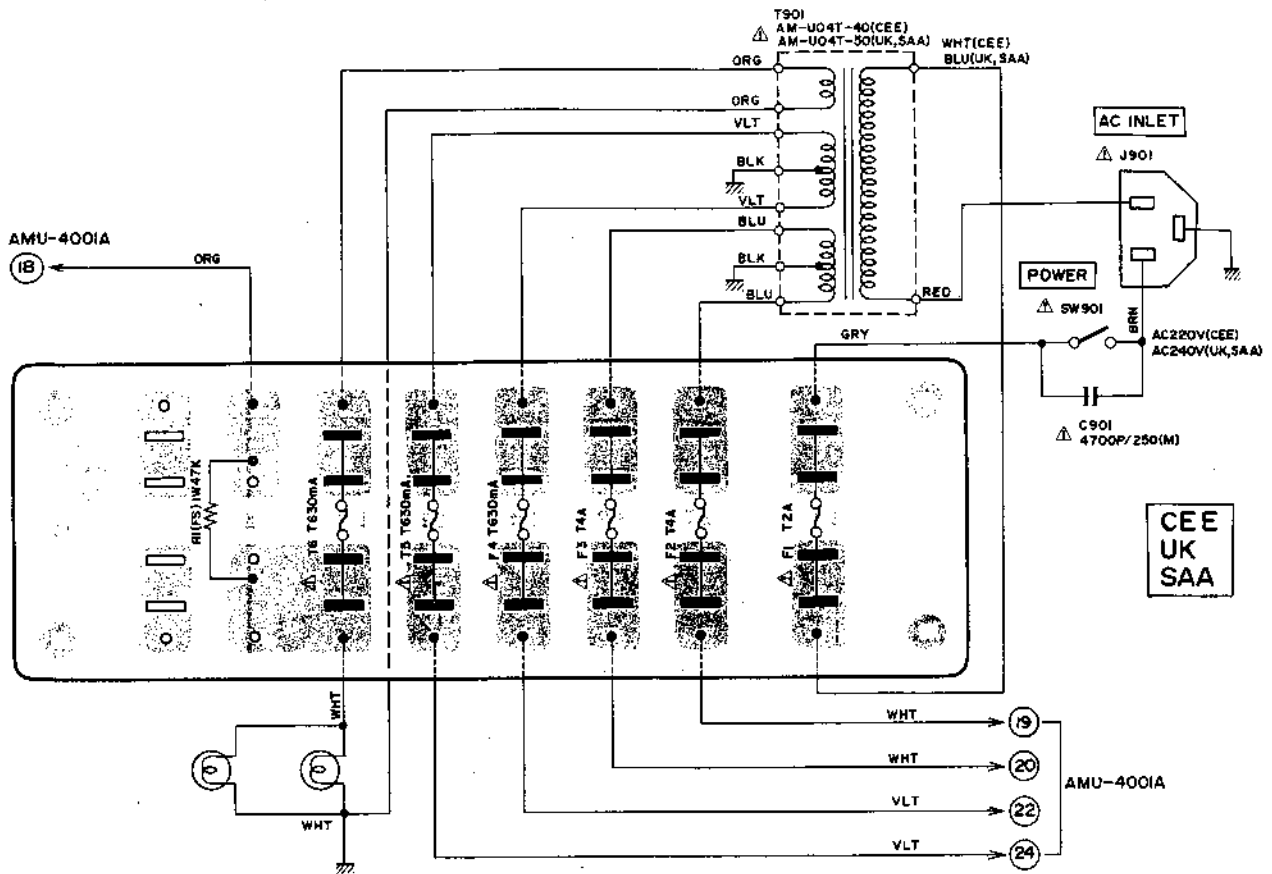

WARNING: INDICATES SAFETY CRITICAL COMPONENTS. FOR CONTINUED SAFETY, REPLACE SAFETY CRITICAL COMPONENTS ONLY WITH MANUFACTURER'S RECOMMENDED PARTS.
 AVERTISSEMENT: IL INDIQUE LES COMPOSANTS CRITIQUES DE SÉCURITÉ. POUR MAINTENIR LE Degré DE SÉCURITÉ DE L'APPAREIL, SEULEMENT LES COMPOSANTS DONT LE FONCTIONNEMENT EST CRITIQUE POUR LA SÉCURITÉ DEVRAIENT ÊTRE REMPLACÉS PAR LES PIÈCES RECOMMANDÉES PAR LE FABRICANT.

SECTION 2

PARTS LIST

TABLE OF CONTENTS

1. RECOMMENDED SPARE PARTS LIST	26
2. MAIN AMP P.C BOARD (AMU-4001A) BLOCK	28
3. TONE CONTROL P.C BOARD (AMU-4003) BLOCK	28
4. SELECTOR P.C BOARD (AMU-4002) BLOCK	29
5. PUSH SW. P.C BOARD (AMU-4001B) BLOCK	29
6. LOUDNESS P.C BOARD (AMU-2003) BLOCK	29
7. BAR METER P.C BOARD (AMU-2006) BLOCK	29
8. ASSEMBLY BLOCK	30
9. FINAL ASSEMBLY BLOCK	32
INDEX	33

Resistor and Capacitor which is not listed in this parts list, please refer to COMMON LIST FOR SERVICE PARTS.

HOW TO USE THIS PARTS LIST

1. This parts list is compiled by various individual blocks based on assembly process.
2. When ordering parts, please describe parts number, serial number, and model number in detail.
3. How to read list.

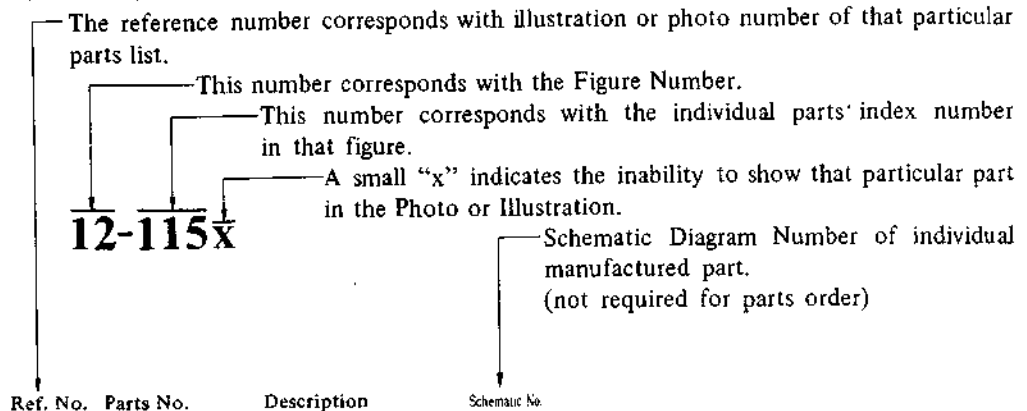

4. The symbol numbers shown on the P.C. Board list can be matched with the Composite Views of components of the Schematic Diagram or Service Manual.
5. The indications of Resistors and Capacitors in the photos of P.C. Board are being eliminated.
6. The shape of the parts and parts name, etc. can be confirmed by comparing them with the parts shown on the Electrical Parts Table of P.C. Board.
7. Both the kind of part and installation position can be determined by the Parts Number. To determine where a parts number is listed, utilize Parts Index at end of Parts List.
It is necessary first of all to find the Parts Number. This can be accomplished by using the Reference Number listed at right of parts number in the Parts Index. (meaning of ref. no. outlined in Item 3 above).
8. Utilize separate "Price List for Parts" to determine unit price. The most simple method of finding parts Price is to utilize the reference number.

CAUTION:

1. When placing an order for parts, be sure to list the parts no., model no., and description. There are instances in which if any of this information is omitted, parts cannot be shipped or the wrong parts will be delivered.
2. Please be careful not to make a mistake in the parts no. If the parts no. is in error, a part different from the one ordered may be delivered.
3. Because parts number and parts unit supply in the Preliminary Service Manual (Basic Parts List) may be partially changed, please use this parts list for all future reference.

WARNING: Δ INDICATES SAFETY CRITICAL COMPONENTS. FOR CONTINUED SAFETY, REPLACE SAFETY CRITICAL COMPONENTS ONLY WITH MANUFACTURER'S RECOMMENDED PARTS.

AVERTISSEMENT: Δ IL INDIQU LES COMPOSANTS CRITIQUES DE SURETE. POUR MAINTENIR LE DEGRE DE SECURITE DE L'APPAREIL NE REMPLACER LES COMPOSANTS DONT LE FONCTIONNEMENT EST CRITIQUE POUR LA SECURITE QUE PAR DES PIECES RECOMMANDEES PAR LE FABRICANT.

AC INLET SYSTEM

This model is equipped with an AC INLET SYSTEM. Please refer to the AC INLET SYSTEM CHART below for the specific type. By the AC INLET SYSTEM, AC (mains) cord can be connected to and disconnected from the model because the model is provided with socket exclusively for AC (mains) cord on its main body. Please note, however, that certain models are not equipped with this system and has a built-in AC (mains) cord as before.

AC INLET SYSTEM CHART

CLASS I

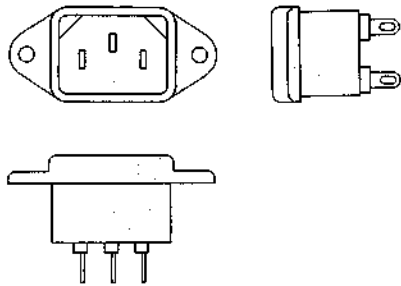

Picture 1
AC INLET
to be
installed
on machines

CLASS II

☐ This mark indicating double insulation will be attached to machine's rear panel

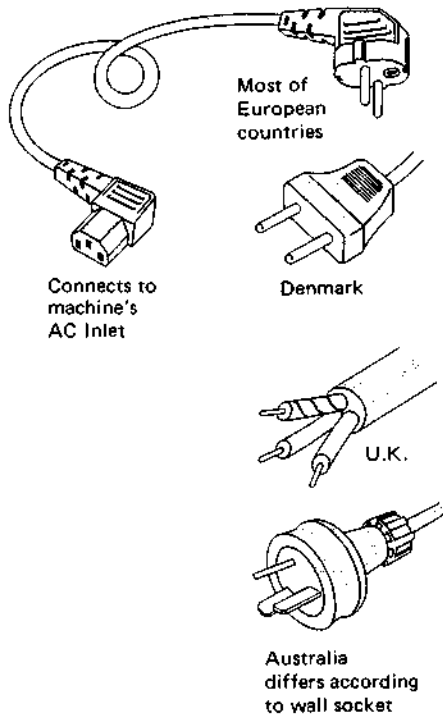
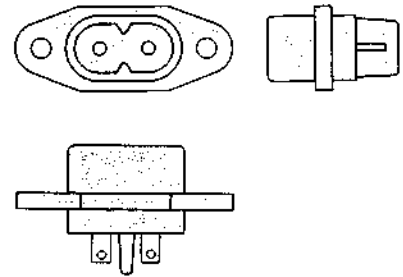

Picture 2
AC (mains)
cord

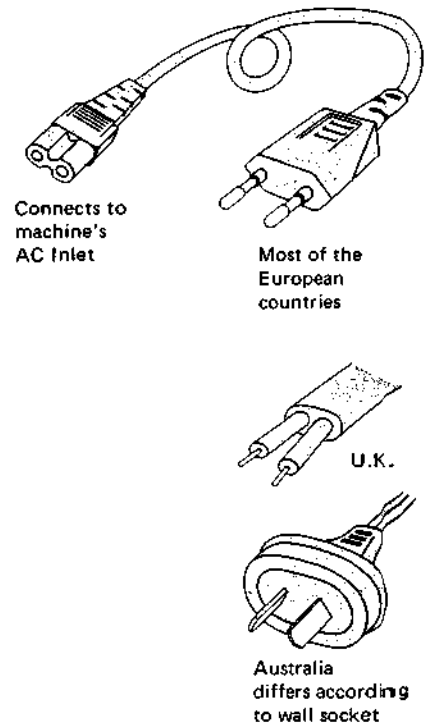

Parts List for AC (mains) Cord Set

Standard		Description	Type of AC Inlet	Parts No.
Class I	CEE	Cord Set CEE (3 cores)	3P	EW302993
	BEAB	Cord Set BEAB (3 cores)	3P	EW302994
	SAA	Cord Set SAA (3 cores)	3P	EW302996
	U/T	Cord Set U/T (3 cores)	3P	EW302646
Class II	CEE	Cord Set CEE (2 cores)	2P	EW638144
	BEAB	Cord Set BEAB (2 cores)	2P	EW302995
	SAA	Cord Set SAA (2 cores)	2P	EW302991
	U/T	Cord Set U/T (2 cores)	2P	EW302899

1. RECOMMENDED SPARE PARTS LIST

Because, if the parts listed below are on hand, almost any repair can be accomplished, we suggest that you stock these Recommended Spare Parts Items.

Parts No.	Description	Notes
BA323094	Main Amp PCB Comp. AM-U04	
BA323135	Selector PCB Comp. AM-U04	
BA323132	Tone Control PCB Comp. AM-U04	
BT320540	△ Power Trans. AM-U04T-10	JPN
BT324165	△ Power Trans. AM-U04T-20	AAL
BT324166	△ Power Trans. AM-U04T-30	CSA
BT324167	△ Power Trans. AM-U04T-40	CEE
BT324168	△ Power Trans. AM-U04T-50	UK, SAA
BT324164	△ Power Trans. AM-U04T-70	U/T
EC321302	△ Ceramic/C. E 0.01μF(Z) 250VAC	U/T, JPN
EC314688	△ Ceramic/C. DE7150 FZ 0.01μF(P) 125WV	CSA, AAL
EC301320	△ MP/C. 4700PF(M) 250WV	CEE, UK, SAA
ED562386	Germanium Diode 1S188AM	
ED322772	LED SLP-155D-01	
ED322773	LED SLP-255D-01	
ED323056	Silicon Diode 1S2091	
ED214457	Silicon Diode 1S2472	
ED624903	Silicon Diode 1S2473	
ED224548	Silicon Diode 10D2	
ED323149	Silicon Stack 1G4B41	
ED323556	Silicon Stack 3G4B41	
ED323057	Silicon Varister MV12	
ED323057	Silicon Varister MV12	
ED322810	Zener Diode WZ-040	
ED242368	Zener Diode WZ-240	
ED323059	Zener Diode WZ-270	
ED323534	Zener Diode 05Z-20U	
ED323535	Zener Diode 05Z-8.2L	
ED322774	Zener Diode 05Z5.1U	
EF306957	△ Fuse 4A 125V	CSA, AAL
EF306952	△ Fuse 4A 250V	U/T, JPN
EF309391	△ Fuse 800mA 125V	CSA, AAL
EF309388	△ Fuse 800mA 250V	JPN
EF601301	△ Fuse (SEMKO T) 2AT	CEE, UK, SAA
EF690996	△ Fuse (SEMKO T) 4AT	CEE, UK, SAA
EF601942	△ Fuse (SEMKO T) 630MAT	CEE, UK, SAA
EI322791	IC LC7556	
EI323146	IC STK-0050 (2)	
EI323563	IC STK-3042	
EI323564	IC TA7317P	
EI323054	IC TA7322P	

Parts No.	Description	Notes
EI322599	IC TA75458S	
EJ240535	△ 3-Throw AC Outlet	U/T, JPN, CSA, AAL
EJ296853	△ 3P In-Let CM-3	CEE, UK, SAA
EM322584	Bar Meter FIP48DW16YS	
EO324150	Phase Compensation Coil 2.2μH(K)	
EP323565	Relay G2Z-222P-20 DC24V	
ES324162	△ Push SW. SDG-1P TV-5	U/T
ES679566	△ Push SW. SDG1P TV5	CSA, AAL
ES310839	△ Push SW. SDG1P-E 5A/80A 250V	CEE, UK, SAA
ES315158	△ Push SW. SDV1P (JPN)	JPN
ES323081	Push SW. J-K2114	
ES322776	Rotary Slide SW. SRZW44S	
ES323062	Rotary SW. SRJ3035	
ES323063	Rotary SW. SRJ3036	
ET311792	FET 2SK150 (GR) (Y)	
ET322244	Transistor 2SA608K-NP (F) (G)	
ET322244	Transistor 2SA608K-NP (F) (G)	
ET311791	Transistor 2SA968 (O) (Y)	
ET305463	Transistor 2SA970 (GR) (BL)	
ET219868	Transistor 2SB560 (E) (F)	
ET307195	Transistor 2SC2240 (GR) (BL)	
ET316643	Transistor 2SC536K-NP (F) (G)	
ET323105	Transistor 2SD600 (E) (F)	
EV478686	Semi-fixed/Vol. V8K4-1 1kB	
EV464196	Semi-fixed/Vol. V8K4-1 2kB	
EV324346	Single-Axial 2-Throw/Vol. V16L4G3N 250KZx2	
EV323061	2-Throw Slide/Vol. 250K (Special) x2	
EV323051	2-Throw/Vol. GM70E838A-50KCx2	
EV323052	2-Throw/Vol. GM70E839A-50KCx2	
EV323053	2-Throw/Vol. GM70E892A-50KWx2	
EW306427	△ AC Cord (JPN)	
EW306428	△ AC Cord (U/T)	
EW305691	△ AC Cord CUL	CSA, AAL

2. MAIN AMP P.C BOARD (AMU-4001A)

BLOCK

Symbol No.	Parts No.	Description	Schematic No.
2-1	BA323094	Main Amp PCB Comp. AM-U04	AMU-4001
2-IC2	EI323563	IC STK-3042	45-8-423
2-IC4	EI322599	IC TA75458S	45-8-415
2-IC5	EI323564	IC TA7317P	45-8-424
2-TR1	ET307195	Transistor 2SC2240 (GR)(BL)	45-1-302
2-TR2,3	ET322244	Transistor 2SA608K-NP (F)(G)	45-1-375
2-TR4,5	ET316643	Transistor 2SC536K-NP (F)(G)	45-1-362
2-TR6,7	ET307195	Transistor 2SC2240 (GR)(BL)	45-1-302
2-TR8	ET305463	Transistor 2SA970 (GR)(BL)	45-1-303
2-TR9	ET323105	Transistor 2SD600(E)(F)	45-1-383
2-TR10	ET307195	Transistor 2SC2240 (GR)(BL)	45-1-302
2-TR11	ET305463	Transistor 2SA970 (GR)(BL)	45-1-303
2-TR12	ET311791	Transistor 2SA968(O)(Y)	45-1-338
2-TR13	ET322244	Transistor 2SA608K-NP (F)(G)	45-1-375
2-TR14,15	ET316643	Transistor 2SC536K-NP (F)(G)	45-1-362
2-TR16	ET311792	FET 2SK150 (GR)(Y)	45-12-22
2-TR17	ET323105	Transistor 2SD600 (E)(F)	45-1-383
2-D1,2	ED323556	Silicon Stack 3G4B41	45-2-98
2-D3	ED323149	Silicon Stack 1G4B41	45-2-99
2-D4,5	ED323056	Silicon Diode 1S2091	45-3-66
2-D6to9	ED323057	Silicon Varister MV12	45-10-16
2-D10to15	ED214457	Silicon Diode 1S2472	45-3-41
2-D16	ED323057	Silicon Varister MV12	45-10-16
2-D17	ED624903	Silicon Diode 1S2473	45-3-28
2-D18,19	ED224548	Silicon Diode 10D2	45-2-14
2-D20	ED214457	Silicon Diode 1S2472	45-3-41
2-D21	ED624903	Silicon Diode 1S2473	45-3-28
2-D22,23	ED242368	Zener Diode WZ-240	45-6-37
2-D24	ED562386	Germanium Diode 1S188AM	45-3-24
2-D25	ED323535	Zener Diode 05Z-8.2L	45-6-76
2-D26	ED323534	Zener Diode 05Z-20U	45-6-76
2-D27	ED624903	Silicon Diode 1S2473	45-3-28
2-VR1	EV478686	Semi-fixed/Vol. V8K4-1 1k Ω	36-10-266
2-VR2	EV464196	Semi-fixed/Vol. V8K4-1 2k Ω	36-10-266
2-RL1,2	EP323565	Relay G2Z-222P-20 DC24V	47-2-35
2-L1	EO324150	Phase Compensation Coil 2.2 μ H(K)	23-1-397
2-R71to73	ER323074	Carbon/R. F 1/4WS 1K(J)	35-11-30
2-R74,75	ER322591	Carbon/R. F 1/4WS 100 ohms (J)	35-11-30
2-R76,77	ER323075	Carbon/R. F 1/4WS 4.7K (J)	35-11-30
2-R78	ER308875	Carbon/R. F 1/2W 10 ohms (J)	35-11-27
2-R80,81	ER442686	Metal Oxide Film/R. 1W 1.2K (K)	35-15-10
2-R82,83	ER658034	Metal Oxide Film/R. 2W 220 ohm (J)	35-19-2
2-R86	ER322590	Cement/R. (Metal Plate) 5W(0.47+0.47) ohms(K)	35-16-84
2-R89	ER324480	Carbon/R. F 1/4WS 47 ohms (J)	35-11-30
2-C3	EC657044	NP/C. (Vert.) 1 μ F(M) 50WV	24-17-26
2-C24to27	EC324156	Elect./C. 6800 μ F 50WV	24-12-44
2-C51	EC322994	Polyester Film/C. (Vert.) 0.0015 μ F(I) 50WV	24-1-15
2-C52	EC314715	Polyester Film/C. (Vert.) 0.0012 μ F(J) 50WV	24-1-15
2-C53,54	EC324199	Polyester Film/C. (Vert.) 0.1 μ F(K) 50WV	24-1-15
2-2	ZS325495	Tapping Screw, #2, BR 3x6	

3. TONE CONTROL P.C BOARD (AMU-4003)

BLOCK

Symbol No.	Parts No.	Description	Schematic No.
3-1	BA323132	Tone Control PCB Comp. AM-U04	AMU-4047
3-IC1	EI323054	IC TA7322P	45-8-419
3-IC2	EI322599	IC TA75458S	45-8-415
3-VR1	EV323051	2-Throw/Vol. GM70E838A-50KCx2	36-22-59
3-VR2	EV323052	2-Throw/Vol. GM70E839A-50KCx2	36-22-58
3-VR3	EV323053	2-Throw/Vol. GM70E892A-50KWx2	36-22-60
3-VR4	EV324346	Single-Axial 2-Throw/Vol. V16L4G3N 250KZx2	36-22-65
3-C1	EC323055	NP/C. 10 μ F(M) 16WV	24-17-35
3-C8,9	EC323055	NP/C. 10 μ F(M) 16WV	24-17-35
3-C10	EC314724	Polyester Film/C. (Vert.) 0.0027 μ F(J) 50WV	24-1-15
3-C11	EC314754	Polyester Film/C. (Vert.) 0.033 μ F(J) 50WV	24-1-15
3-C12	EC314751	Polyester Film/C. (Vert.) 0.027 μ F(J) 50WV	24-1-15
3-C13	EC324154	Polyester Film/C. (Vert.) 0.068 μ F(I) 50WV	24-1-15
3-C15	EC243393	Solid Aluminum/C. (Vert.) 0.22 μ F(K) 10WV	24-19-2

When ordering parts, please quote Parts Number, Description and Model Number.

4. SELECTOR P.C BOARD (AMU-4002) BLOCK

Symbol No.	Parts No.	Description	Schematic No.
4-1	BA323135	Selector PCB Comp. AM-U04	AMU-4049
4-IC1	EI323054	IC TA7322P	45-8-419
4-TR1	ET219868	Transistor 2SB560 (E)(F)	45-1-232
4-D1,2	ED323059	Zener Diode WZ-270	45-6-67
4-SW1	ES323062	Rotary SW. SRJ3035	25-6-191
4-SW2	ES323063	Rotary SW. SRJ3036	25-6-192
4-R7	ER323351	Metal Film/R. 1/4W 3.74K(F)	35-17-20
4-R8	ER323069	Metal Film/R. 1/4W 46.4 ohms (F)	35-17-20
4-C3	EC318358	NP/C. 47 μ F(M) 6.3WV	24-17-35
4-C9	EC324102	Polypropylene/C. (Vert.) 0.02 μ F(G) 50WV	24-22-10
4-C10	EC324103	Polypropylene/C. (Vert.) 0.0697 μ F(G) 50WV	24-22-10
4-C11	EC323055	NP/C. 10 μ F(M) 16WV	24-17-35

5. PUSH SW. P.C BOARD (AMU-4001B) BLOCK

Symbol No.	Parts No.	Description	Schematic No.
5-TR1,2	ET316643	Transistor 2SC536K-NP (F) (G)	45-1-362
5-SW1to6	ES323081	Push SW. J-K2114	25-5-361
5-C1	EC314736	Polyester Film/C. (Vert.) 0.0068 μ F(J) 50WV	24-1-15
5-C2	EC314771	Polyester Film/C. (Vert.) 0.15 μ F(J) 50WV	24-1-15

6. LOUDNESS P.C BOARD (AMU-2003) BLOCK

Symbol No.	Parts No.	Description	Schematic No.
6-SW1	ES322776	Rotary Slide SW. SRZW44S	25-6-188
6-C2	EC321173	Styrol/C. 180PF(J) 50WV	24-11-14
6-C3	EC306988	Styrol/C. 330PF(J) 50WV	24-11-14

7. BAR METER P.C BOARD (AMU-2006) BLOCK

Symbol No.	Parts No.	Description	Schematic No.
7-IC1	EI322791	IC LC7556	45-8-425
7-D1	ED322774	Zener Diode 05Z5.1U	45-6-76
7-D2	ED322810	Zener Diode WZ-040	45-6-67
7-IND1	EM322584	Bar Meter FIP48DW16YS	59-1-2
7-1	ZS422076	Screw, pan 3x5	

8. ASSEMBLY BLOCK

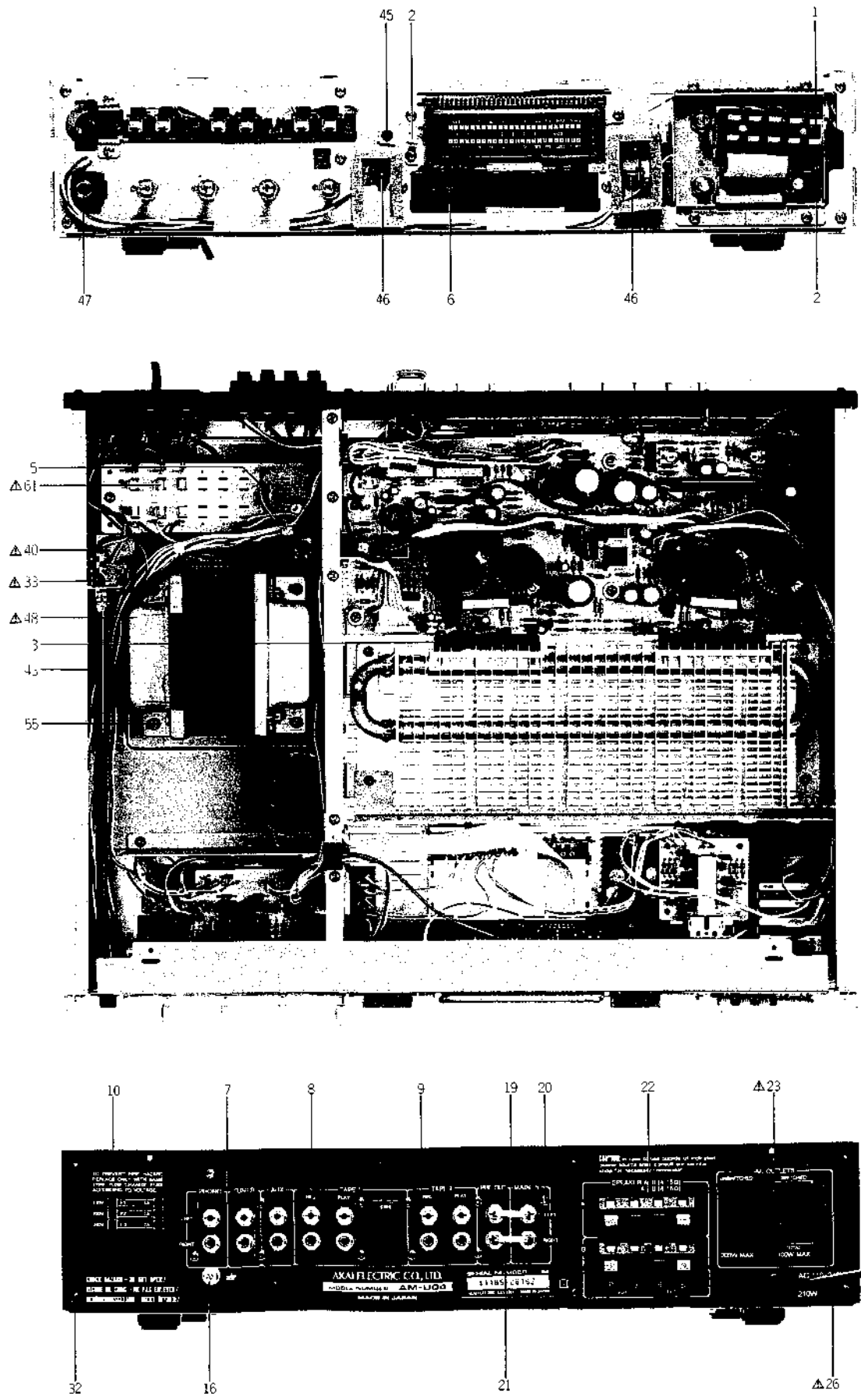

ASSEMBLY BLOCK

Ref. No.	Parts No.	Description	Schematic No.	Ref. No.	Parts No.	Description	Schematic No.
LED P.C BOARD BLOCK							
8-1	ED322773	LED SLP-255D-01	45-15-37	8-47	EJ301199	Headphone Jack 3P64M	31-2-83
8-2	ED322772	LED SLP-155D-01	45-15-38	8-48	BT324164	△ Power Trans. AM-U04T-70 (U/T)	38-4-793
HEAT SINK BLOCK							
8-3	EI323146	IC STK-0050 (2)	45-8-433	8-49x	BT320540	△ Power Trans. AM-U04T-10 (JPN)	38-4-854
8-4x	ZS321279	Tapping Screw, #2 BR 3x18		8-50x	BT324166	△ Power Trans. AM-U04T-30 (CSA)	38-4-790
FUSE P.C BOARD BLOCK							
8-5	ER324359	Metal Oxide Film/R. F 1W 56 ohms (J)	35-19-4	8-51x	BT324165	△ Power Trans. AM-U04T-20 (AAL)	38-4-789
SLIDE VOL. P.C BOARD BLOCK							
8-6	EV323061	2-Throw Slide/Vol. 250K (Special)x2	36-27-9	8-52x	BT324167	△ Power Trans. AM-U04T-40 (CEE)	38-4-791
PIN JACK P.C BOARD BLOCK							
8-7	EJ323143	4P Pin Jack	31-5-159	8-53x	BT324168	△ Power Trans. AM-U04T-50 (UK, SAA)	38-4-792
8-8	EJ323144	6P Pin Jack	31-5-158	8-54x	ZW413267	Flange Nut M4	
8-9	EJ323145	5P Din, 4P Pin Jack	31-5-157	8-55	ZS424056	Screw, pan 4x10	
REAR PANEL BLOCK							
8-10	SP323019	Rear Panel (U/T)	AMU-4021	8-56x	ZS434250	Screw, pan 4x8 W/Washer	
8-11x	SP320541	Rear Panel (JPN)	AMU-4057	8-57x	ZS498273	Tapping Screw #2, BR 3x8	W=8
8-12x	SP323022	Rear Panel (CSA)	AMU-4022	8-58x	ZS297641	Tapping Screw #2, Bind 3x8	W=10
8-13x	SP323020	Rear Panel (AAL)	AMU-4022	8-59	EC258333	Ceramic/C. DB207YF 0.047μF(Z) 50WV	24-5-68
8-14x	SP323023	Rear Panel (CEE)	AMU-4023	8-60x	EC258333	Ceramic/C. DB207YF 0.047μF(Z) 50WV	24-5-68
8-15x	SP323024	Rear Panel (UK, SAA)	AMU-4023	8-61	EF306952	△ Fuse 4A 250V (U/T, JPN)	39-1-64
8-16	EJ325358	Earth Terminal	32-1-115	8-62x	EF309388	△ Fuse 800mA 250V (JPN)	39-1-64
8-17x	ZW652408	Washer (SPC) D3.2x10x0.5t		8-63x	EF306957	△ Fuse 4A 125V (CSA, AAL)	39-1-65
8-18x	ZS308673	Tapping Screw, pan 3x20 W/Guide	7-1-68	8-64x	EF309391	△ Fuse 800mA 125V (CSA, AAL)	39-1-65
8-19	EJ322581	4P Pin Jack (Red, White)	32-1-106	8-65x	EF601301	△ Fuse (SEMKO T) 2AT (CEE, UK, SAA)	39-1-53
8-20	ZS522865	Tapping Screw, #2 BR 3x12 (Black)		8-66x	EF609996	△ Fuse (SEMKO T) 4AT (CEE, UK, SAA)	39-1-53
8-21	EJ554578	Short Plug	42-1-66	8-67x	EF601942	△ Fuse (SEMKO T) 630MAT (CEE, UK, SAA)	39-1-53
8-22	EJ322582	4P Push Terminal	32-1-107				
8-23	EJ240535	△ 3-Throw AC Outlet (U/T, JPN, CSA, AAL)	31-1-173				
8-24x	EJ296853	△ 3P In-Let CM-3 (CEE, UK, SAA)	31-1-199				
8-25x	ZS463353	Tapping Screw, #2 BR 3x8 (Black)					
8-26	EW306428	△ AC Cord (U/T)	26-3-64				
8-27x	EW306427	△ AC Cord (JPN)	26-3-63				
8-28x	EW305691	△ AC Cord CUL (CSA, AAL)	26-3-65				
8-29	EZ631945	Strain Relief SR-4N-4	2-7-49				
8-30x	ZW305013	Pop Rivet D3.2 (AAL)	7-6-9				
ASSEMBLY BLOCK							
8-31x	ZS325495	Tapping Screw, #2 BR 3x6					
8-32	ZS308846	Tapping Screw, #2 BR 3x8 (Oval Neck)	7-1-69				
8-33	ES324162	△ Push SW. SDG-1P TV-5 (U/T)	25-5-377				
8-34x	ES315158	△ Push SW. SDV1P (JPN)	25-5-329				
8-35x	ES679566	△ Push SW. SDG1P TV5 (CSA, AAL)	25-5-204				
8-36x	ES310839	△ Push SW. SDG1P-E 5A/80A 250V (CEE, UK, SAA)	25-5-310				
8-37x	ZS417216	Screw, pan 3x4					
8-38x	ZW616004	Washer D3.1x8x1t					
8-39x	ZS379350	Screw, pan 3x6					
8-40	EC321302	△ Ceramic/C. E 0.01μF(Z) 250VAC (U/T, JPN)	24-5-90				
8-41x	EC314688	△ Ceramic/C. DE7150 FZ 0.01μF(P) 125WV (CSA, AAL)	24-5-87				
8-42x	EC301320	△ MP/C. 4700PF(M) 25WV (CEE, UK, SAA)	24-9-122				
8-43	TA323028	Push Rod	AMU-4027				
8-44x	ZS422076	Screw, pan 3x5					
8-45	ZW698308	Nylon Rivet (NRB) 3x5.5 (Black)	2-7-54				
8-46	EL324355	Lamp (Cord) 8V 50mA (800mmx2)	28-2-84				

9. FINAL ASSEMBLY BLOCK

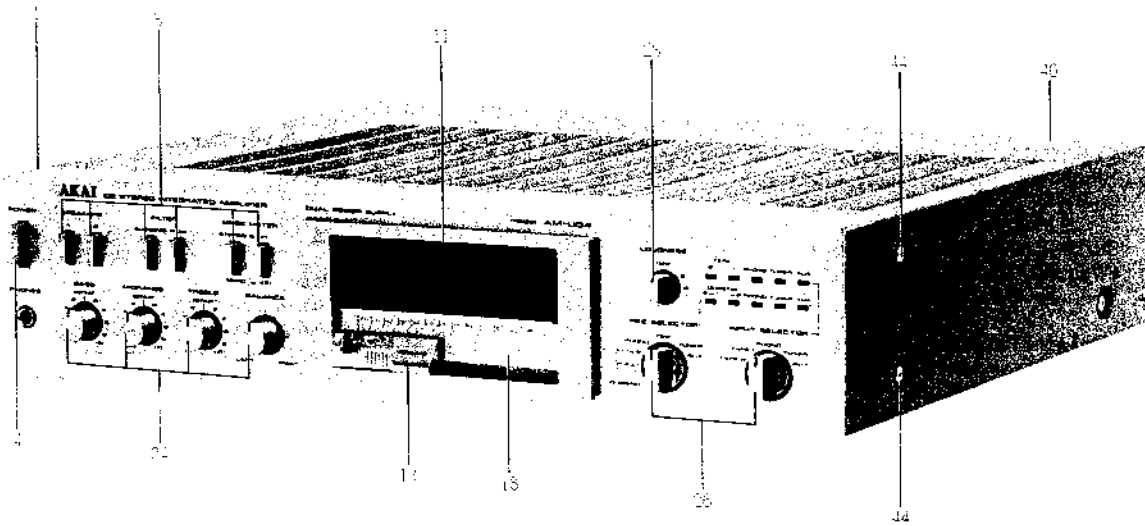

FINAL ASSEMBLY BLOCK

Ref. No.	Parts No.	Description	Schematic No.	Ref. No.	Parts No.	Description	Schematic No.
FRONT PANEL BLOCK				FINAL ASSEMBLY BLOCK			
9-1	BD323101	Front Panel BLK AM-U04	AMU-4055	9-24	SK323042	Knob	AMU-4037
9-2x	BD323102	Front Panel BLK AM-U04-BL	AMU-4055	9-25x	SK323043	Knob (BL)	AMU-4037
9-3x	SE322578	Escutcheon (A)	ATK-2013	9-26	SK322553	Knob (B)	AMU-2042
9-4	SB322576	Button (A)	ATK-2012	9-27x	SK322554	Knob (B-BL)	AMU-2042
9-5x	SB322577	Button (A-BL)	ATK-2012	9-28	SK322555	Knob (C)	AMU-2043
9-6x	ZG322579	Spring (A)	ATK-2014	9-29x	SK322556	Knob (C-BL)	AMU-2043
9-7x	SE322559	Escutcheon	AMU-2045	9-30x	ZW324157	Washer D6.2x13x0.25t	
9-8	SB322557	Button	AMU-2044	9-31x	ZW324158	Washer D6.2x13x0.5t	
9-9x	SB322558	Button (BL)	AMU-2044	9-32x	ZW324159	Washer D6.2x13x0.8t	
9-10x	ZG322566	Spring	AMU-2050	9-33x	ZW265983	Washer D6.2x13x1t	
9-11	SE322538	Bar Meter Escutcheon	AMU-2032	9-34x	ZW324161	Washer D6.2x13x1.6t	
9-12x	SE322539	Bar Meter Escutcheon (BL)	AMU-2032	9-35x	ZS447840	Tapping Screw, #2 BR 3x8	
9-13	SK324171	Slide Knob (A) Part AM-U04	AMU-4061	9-36x	SP323044	Bottom Plate	AMU-4038
9-14x	SK323147	Slide Knob (A-BL) Part AM-U04-BL	AMU-4061	9-37x	ZS447840	Tapping Screw, #2 BR 3x8	
9-15x	ZW270088	'E' Ring 1.9M	6-1-9	9-38x	SA311742	Circular Foot	PC-2032
9-16x	SZ322544	Bar Meter Plate	AMU-2036	9-39x	ZS565942	Tapping Screw, #2 pan 4x8	
9-17x	SZ322545	Bar Meter Filter	AMU-2037, 2058	9-40	SP323045	Upper Plate (A)	AMU-4039
9-18	TA323037	Vol. Illumination Plate	AMU-4033	9-41x	SP323047	Upper Plate (B) (AAL)	AMU-4039
9-19x	SP323038	Scale Back Plate	AMU-4034	9-42x	SP323046	Upper Plate (A-BL)	AMU-4039
9-20x	SP323039	Scale Back Plate (BL)	AMU-4034	9-43x	ZS322570	S-Tight Screw, bind 4x8	
9-21x	ZS322402	Special Tapping Screw, pan 3x8	7-1-70	9-44	ZS322580	S-Tight Screw, bind 4x8 (AAL, BL)	
9-22x	ZW616004	Washer D3.1x8x1t		9-45x	ZS308846	Tapping Screw, #2 BR 3x8 (Oval Neck)	7-1-69
9-23x	SE323041	LED Escutcheon	AMU-4036				

When ordering parts, please quote Parts Number, Description and Model Number.

INDEX

Parts No.	Ref. No. & Symbol No.	Parts No.	Ref. No. & Symbol No.	Parts No.	Ref. No. & Symbol No.	Parts No.	Ref. No. & Symbol No.	Parts No.	Ref. No. & Symbol No.
BA323094	2-1	ED322772	8-2	EJ554578	8-21	EV323052	3-VR2	SZ322544	9-16x
BA323132	3-1	ED322773	8-1	EL324355	8-46	EV323053	3-VR3	SZ322545	9-17x
BA323135	4-1	ED322774	7-D1	EM322584	7-IND1	EV323061	8-6	TA323028	8-43
BD323101	9-1	ED322810	7-D2	EO324150	2-L1	EV324346	3-VR4	TA323037	9-18
BD323102	9-2x	ED323056	2-D4,5	EP323565	2-RL1,2	EV464196	2-VR2	ZG322566	9-10x
BT320540	8-49x	ED323057	2-D6to9	ER308875	2-R78	EV478686	2-VR1	ZG322579	9-6x
BT324164	8-48	ED323057	2-D16	ER322590	2-R86	EW305691	8-28x	ZS297641	8-58x
BT324165	8-51x	ED323059	4-D1,2	ER322591	2-R74,75	EW306427	8-27x	ZS308673	8-18x
BT324166	8-50x	ED323149	2-D3	ER323069	4-R8	EW306428	8-26	ZS308846	8-32
BT324167	8-52x	ED323534	2-D26	ER323074	2-R71to73	EZ631945	8-29	ZS308846	9-45x
BT324168	8-53x	ED323535	2-D25	ER323075	2-R76,77	SA311742	9-38x	ZS321279	8-4x
EC243393	3-C15	ED323556	2-D1,2	ER323351	4-R7	SB322557	9-8	ZS322402	9-21x
EC258333	8-59	ED562386	2-D24	ER324359	8-5	SB322558	9-9x	ZS322570	9-43x
EC258333	8-60x	ED624903	2-D17	ER324480	2-R89	SB322576	9-4	ZS322580	9-44
EC301320	8-42x	ED624903	2-D21	ER442686	2-R80,81	SB322577	9-5x	ZS325495	2-2
EC306988	6-C3	ED624903	2-D27	ER658034	2-R82,83	SE322538	9-11	ZS325495	8-31x
EC314688	8-41x	EF306952	8-61	ES310839	8-36x	SE322539	9-12x	ZS379350	8-39x
EC314715	2-C52	EF306957	8-63x	ES315158	8-34x	SE322559	9-7x	ZS417216	8-37x
EC314724	3-C10	EF309388	8-62x	ES322776	6-SW1	SE322578	9-3x	ZS422076	7-1
EC314736	5-C1	EF309391	8-64x	ES323062	4-SW1	SE323041	9-23x	ZS422076	8-44x
EC314751	3-C12	EF601301	8-65x	ES323063	4-SW2	SK322553	9-26	ZS424056	8-55
EC314754	3-C11	EF601942	8-67x	ES323081	5-SW1to6	SK322554	9-27x	ZS434250	8-56x
EC314771	5-C2	EF690996	8-66x	ES324162	8-33	SK322555	9-28	ZS447840	9-35x
EC318358	4-C3	EI322599	2-IC4	ES679566	8-35x	SK322556	9-29x	ZS447840	9-37x
EC321173	6-C2	EI322599	3-IC2	ET219868	4-TR1	SK323042	9-24	ZS463353	8-15x
EC321302	8-40	EI322791	7-IC1	ET305463	2-TR8	SK323043	9-25x	ZS498273	8-17x
EC322994	2-C51	EI323054	3-IC1	ET305463	2-TR11	SK323147	9-14x	ZS522865	8-20
EC323055	3-C1	EI323054	4-IC1	ET307195	2-TR1	SK324171	9-13	ZS565942	9-39x
EC323055	3-C8,9	EI323146	8-3	ET307195	2-TR6,7	SP320541	8-11x	ZW265983	9-33x
EC323055	4-C11	EI323563	2-IC2	ET307195	2-TR10	SP323019	8-10	ZW270088	9-15x
EC324102	4-C9	EI323564	2-IC5	ET311791	2-TR12	SP323020	8-13x	ZW305013	8-30x
EC324103	4-C10	EJ240535	8-23	ET311792	2-TR16	SP323022	8-12x	ZW324157	9-30x
EC324154	3-C13	EJ296853	8-24x	ET316643	2-TR4,5	SP323023	8-14x	ZW324158	9-31x
EC324156	2-C24to27	EJ301199	8-47	ET316643	2-TR14,15	SP323024	8-15x	ZW324159	9-32x
EC324199	2-C53,54	EJ322581	8-19	ET316643	5-TR1,2	SP323038	9-19x	ZW324161	9-34x
EC657044	2-C3	EJ322582	8-22	ET322244	2-TR2,3	SP323039	9-20x	ZW413267	8-54x
ED214457	2-D10to15	EJ323143	8-7	ET322244	2-TR13	SP323044	9-36x	ZW616004	8-38x
ED214457	2-D20	EJ323144	8-8	ET323105	2-TR9	SP323045	9-40	ZW616004	9-22x
ED224548	2-D18,19	EJ323145	8-9	ET323105	2-TR17	SP323046	9-42x	ZW652408	8-17x
ED242368	2-D22,23	EJ325358	8-16	EV323051	3-VR1	SP323047	9-41x	ZW698308	8-45

SECTION 3

SCHEMATIC DIAGRAM

1. SCHEMATIC DIAGRAM OF ICs
2. AM-U04 No. 2-1 1600438A SCHEMATIC DIAGRAM
3. AM-U04 No. 2-2 1600439A SCHEMATIC DIAGRAM

LC7556

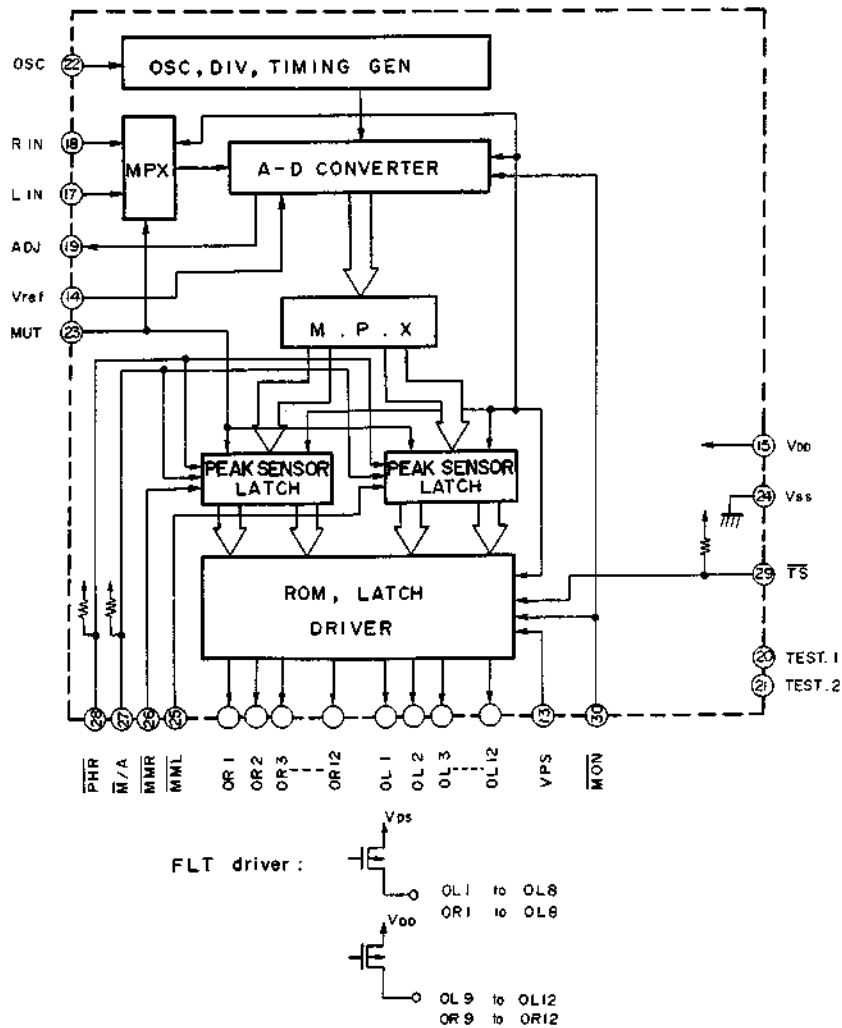

TA7317P

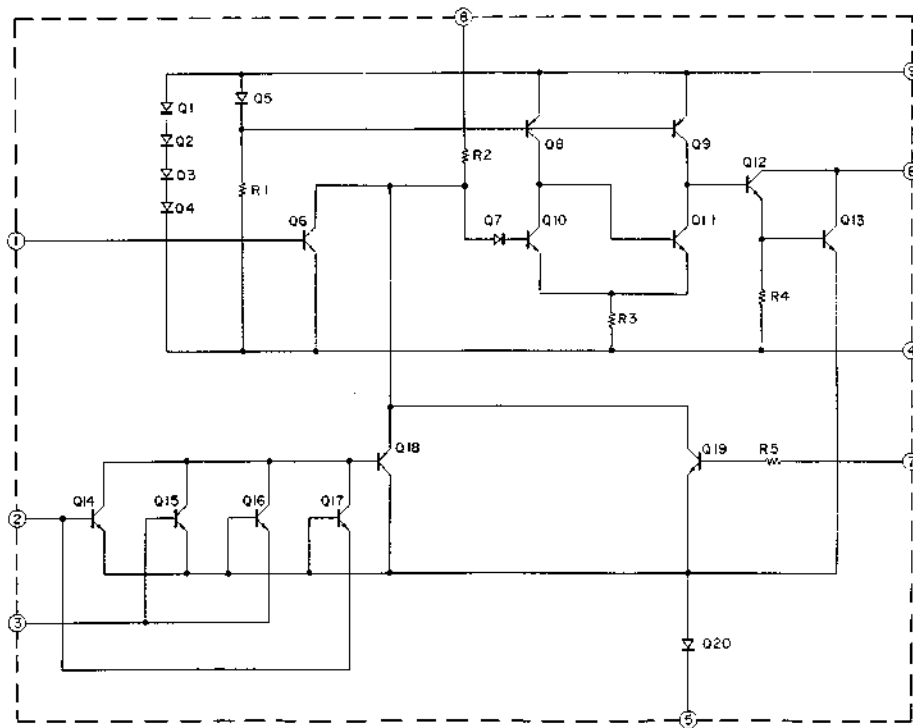
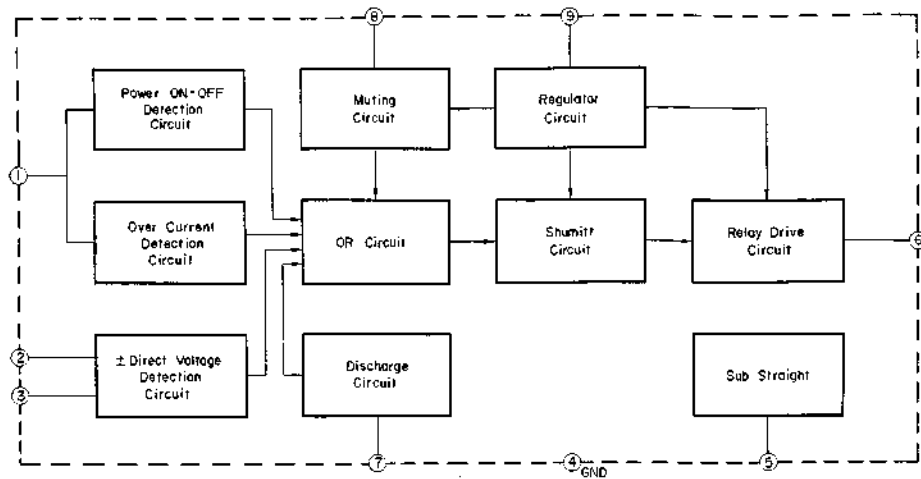

TA7322P

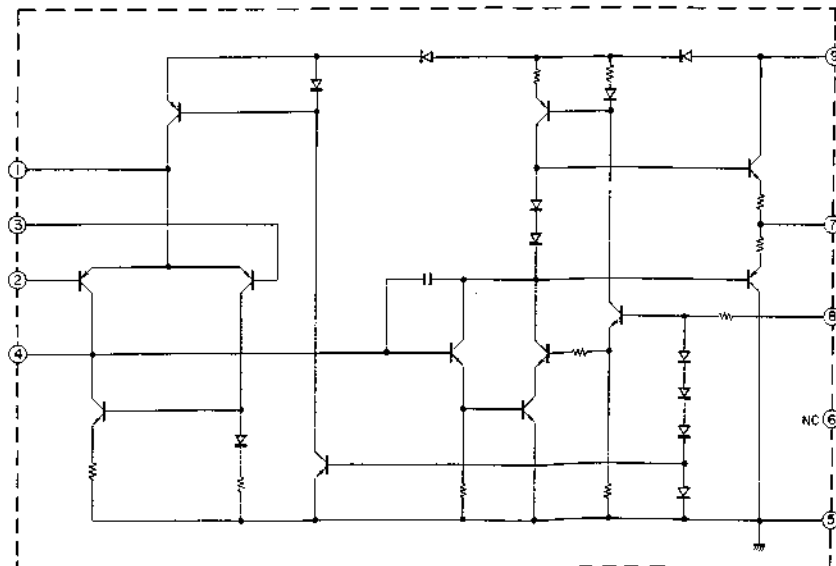

TA75458S

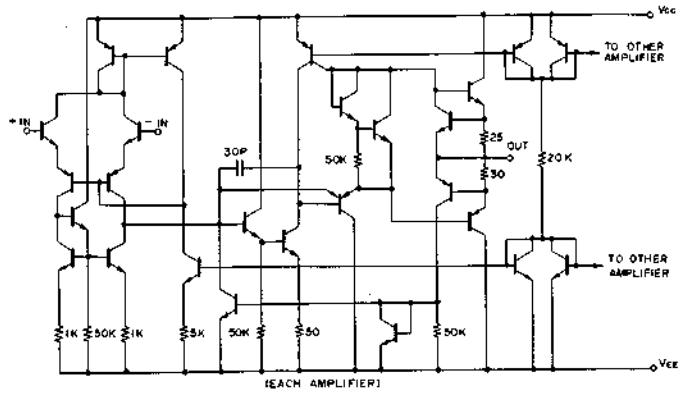
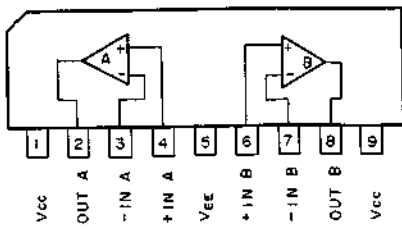

STK-0050II

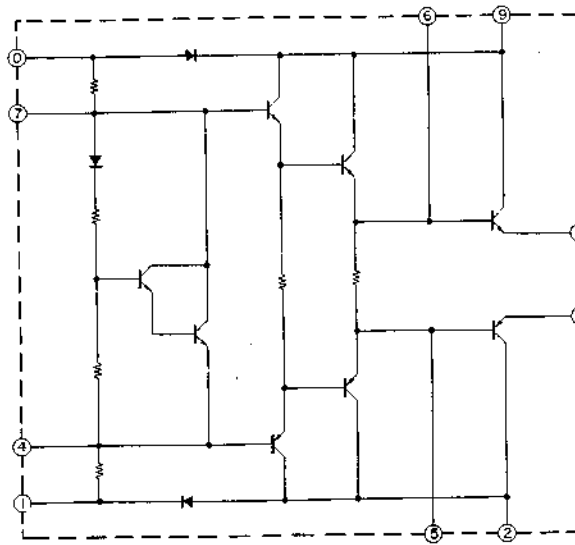

STK-3042

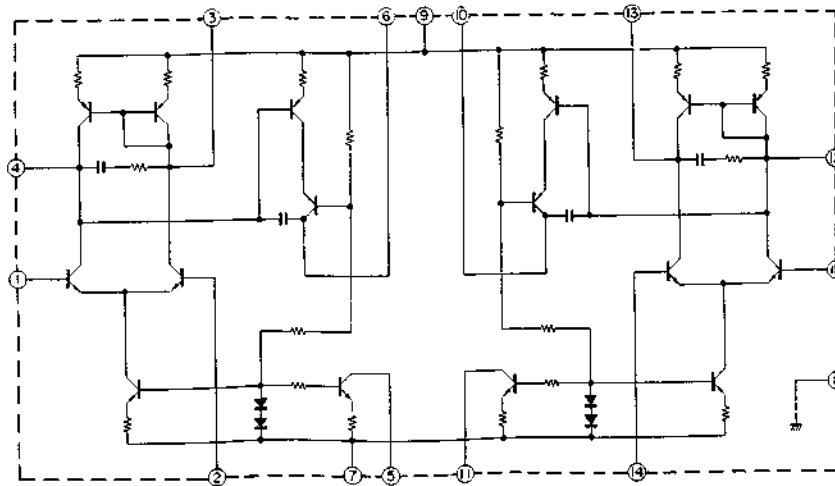

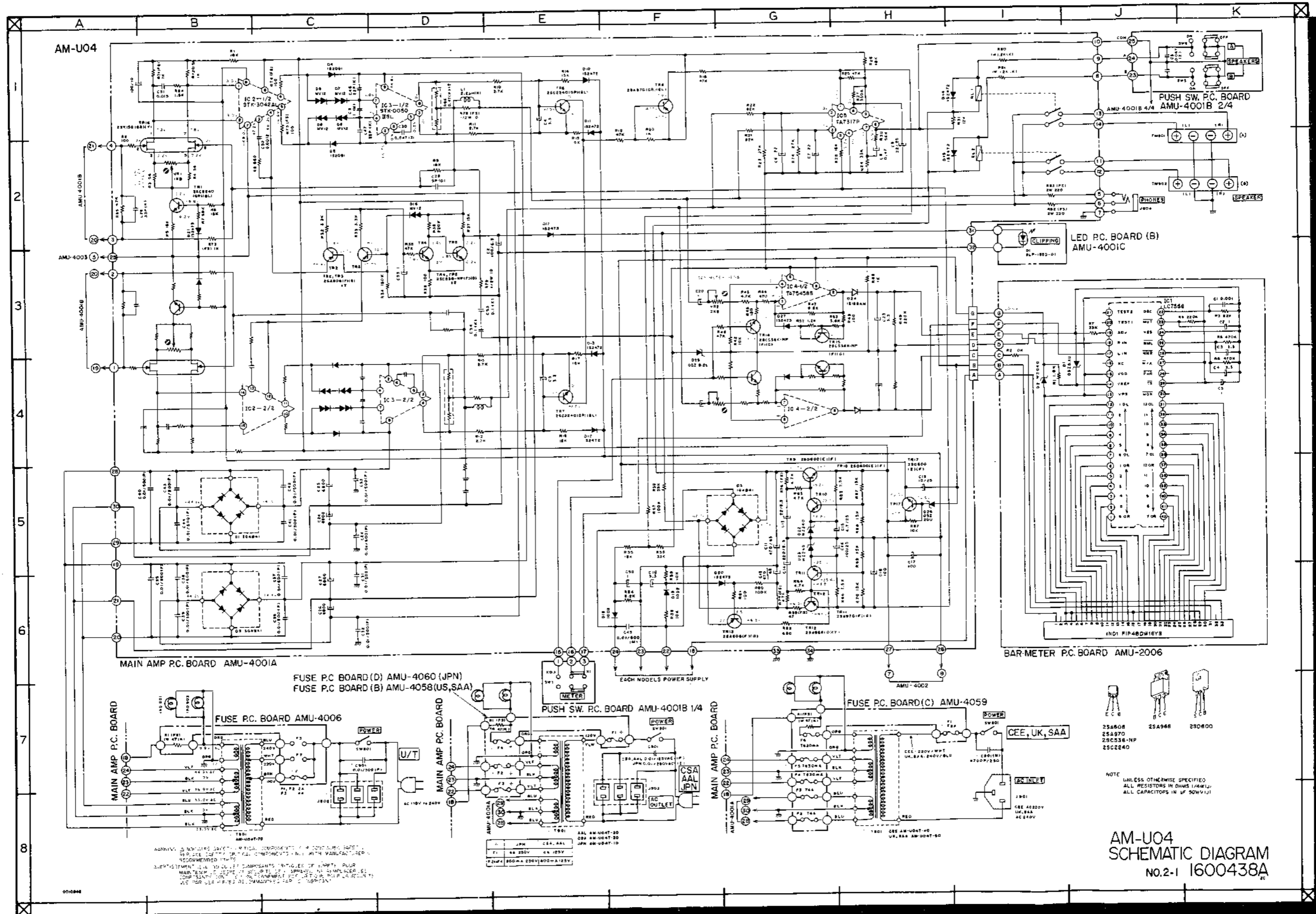

ADDITIONAL COMPONENTS LISTED IN THIS DOCUMENT ARE NOT RECOMMENDED FOR USE IN THIS EQUIPMENT UNLESS THEY ARE MANUFACTURED BY THE MANUFACTURER OF THE ORIGINAL EQUIPMENT OR BY A MANUFACTURER WHOSE EQUIPMENT IS EQUIVALENT TO THAT OF THE ORIGINAL MANUFACTURER.

IC	JPN	CEE, SAA
F1	LA 220V	CA 125V
F2	250MA 250V	400MA 125V

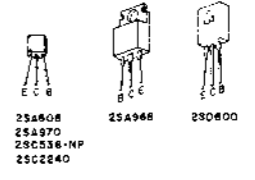

NOTE
UNLESS OTHERWISE SPECIFIED
ALL RESISTORS IN OHMS (AWG)
ALL CAPACITORS IN UF (WV)

AM-U04
SCHEMATIC DIAGRAM
No.2-1 1600438A

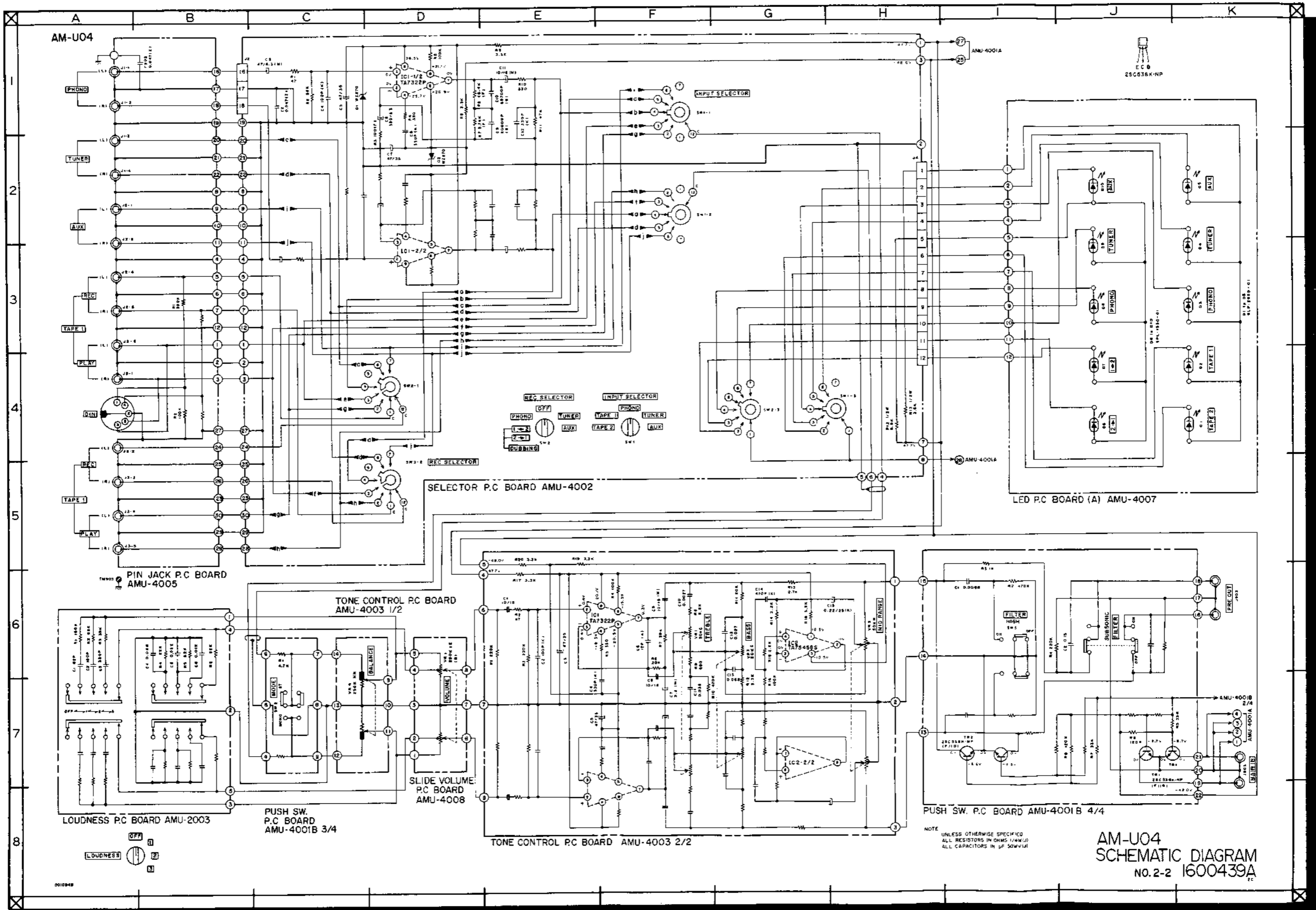

NOTE
UNLESS OTHERWISE SPECIFIED
ALL RESISTORS IN OHMS (1/K=K)
ALL CAPACITORS IN UF (50V=V)

AM-U04
SCHEMATIC DIAGRAM
NO. 2-2 1600439A