

## AKAI STEREO TUNER

### MODEL AT-2400

SECTION 1	SERVICE MANUAL .....	2
SECTION 2	PARTS LIST .....	21
SECTION 3	SCHEMATIC DIAGRAM .....	31

---

SECTION 1

**SERVICE MANUAL**

TABLE OF CONTENTS

I.	TECHNICAL DATA .....	3
II.	DISMANTLING OF UNIT .....	4
III.	CONTROLS .....	5
IV.	PRINCIPAL PARTS LOCATIONS .....	6
V.	OPERATING PRINCIPLES OF QUADRATURE DETECTION SYSTEM ....	7
VI.	OPERATING PRINCIPLES OF PLL CIRCUIT EMPLOYED IN STEREO DEMODULATION CIRCUIT .....	8
	1. PLL CIRCUIT OPERATION .....	8
	2. STEREO DEMODULATION CIRCUIT .....	8
VII.	TUNER SECTION ADJUSTMENT .....	10
	1. FM SECTION ADJUSTMENT .....	11
	2. AM SECTION ADJUSTMENT .....	12
VIII.	TUNING CORD THREADING .....	13
IX.	COMPOSITION OF P.C BOARDS .....	14
	1. FM IF P.C BOARD T2-5420A, LED P.C BOARD T2-5420B .....	14
	2. FRONT END P.C BOARD T2-5421 .....	15
	3. POWER SUPPLY P.C BOARD T2-5419 .....	16



## I. TECHNICAL DATA

### FM TUNER SECTION

FREQUENCY RANGE		88 MHz to 108 MHz
SENSITIVITY (IHF)		1.8 $\mu$ V
CAPTURE RATIO		1.0 dB
SELECTIVITY (IHF)		More than 80 dB
IMAGE REJECTION		More than 90 dB (98 MHz)
IF REJECTION		More than 100 dB (98 MHz)
SPURIOUS REJECTION		More than 100 dB (98 MHz)
AM SUPPRESSION		55 dB
SIGNAL TO NOISE RATIO		75 dB
HARMONIC DISTORTION	MONO	Less than 0.2% (100% modulation)
	STEREO	Less than 0.3% (100% modulation)
TUNING INDICATOR		Signal Strength meter and Center Tuning meter
MUTING		Level Control (5 $\mu$ V to 100 $\mu$ V)/Switchable to ON-OFF
STEREO SEPARATION		More than 42 dB (1 kHz)
SUB CARRIER SUPPRESSION		More than 65 dB
OUTPUT VOLTAGE	VARIABLE	From 0 mV to 1.6V
	FIXED	0.77V (100% modulation)
ANTENNA INPUT IMPEDANCE		300 ohms balanced, 75 ohms unbalanced

### AM TUNER SECTION

FREQUENCY RANGE		520 kHz to 1,605 kHz
SENSITIVITY (IHF)		180 $\mu$ V/m (bar antenna), 15 $\mu$ V (external antenna)
SELECTIVITY (IHF)		More than 30 dB
IMAGE REJECTION		More than 55 dB (1,000 kHz)
IF REJECTION		More than 45 dB
SIGNAL TO NOISE RATIO		More than 50 dB
OUTPUT VOLTAGE	VARIABLE	From 0 mV to 550 mV
	FIXED	250 mV (30% modulation)
ANTENNA		Built-in ferrite bar antenna

### MISCELLANEOUS

SEMI-CONDUCTORS		Transistors: 12. Diodes: 9, FETs: 1, ICs: 4
POWER REQUIREMENTS		CSA, UL and LA models: 120V, 60 Hz CEE models: 220V, 50 Hz Other models: 110/220/240V, 50~60 Hz Switchable
DIMENSIONS		440(W) $\times$ 141(H) $\times$ 336(D) mm (17.3 $\times$ 5.6 $\times$ 13.2) inches
WEIGHT		6.6 kg (14.5 lbs)

\* For improvement purposes, specifications and design are subject to change without notice.

## II. DISMANTLING OF UNIT

In case of trouble, etc. necessitating disassembly, please disassemble in the order shown in photographs. Reassemble in reverse order.

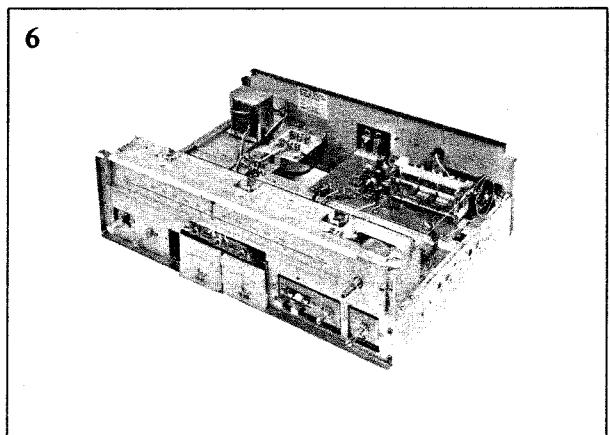
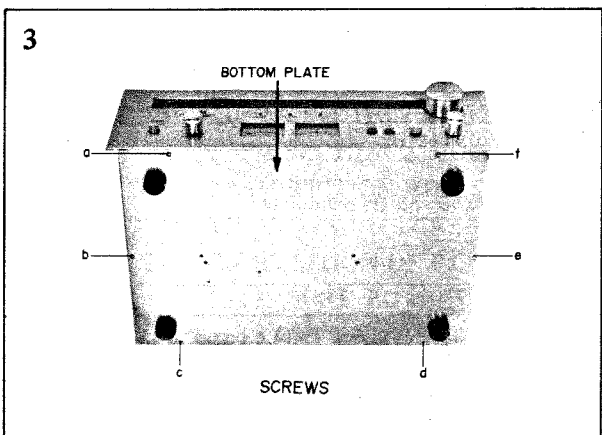
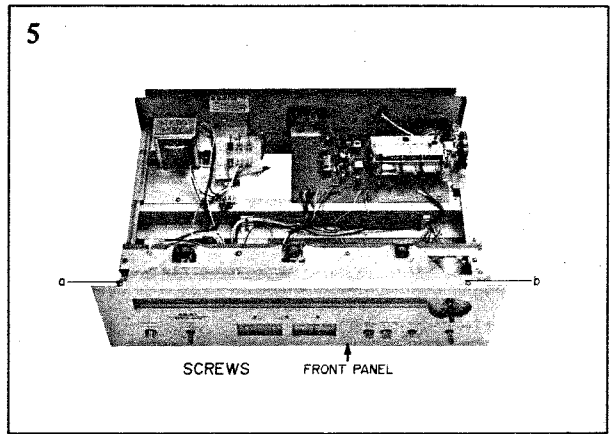
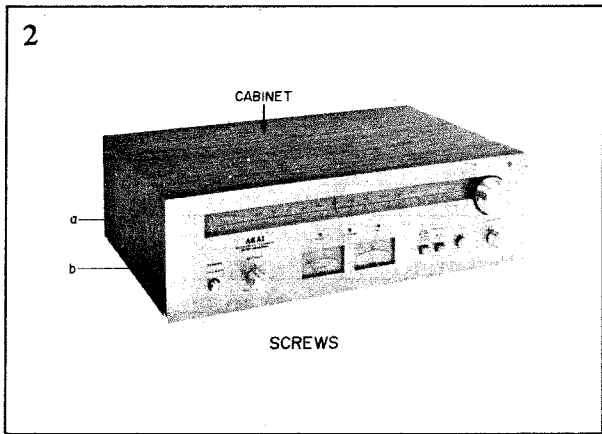
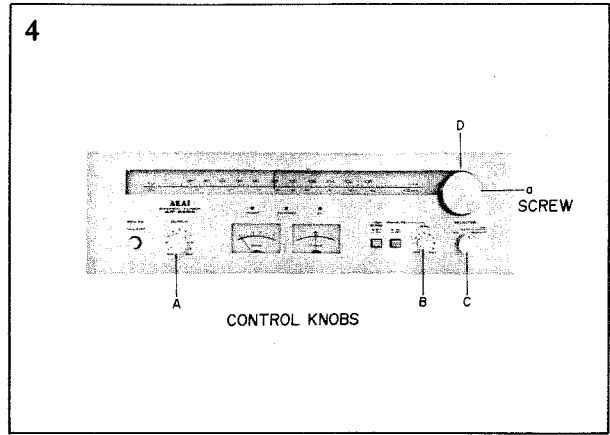
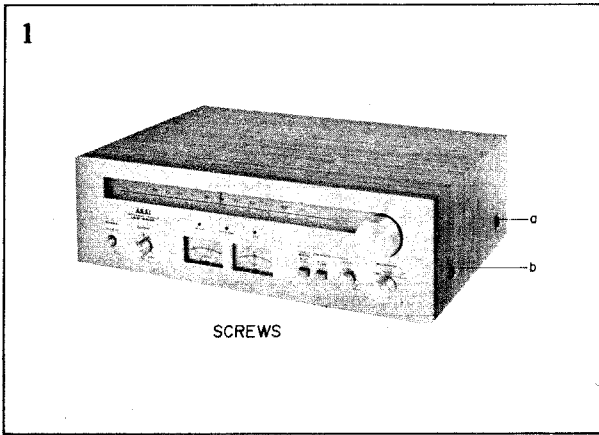

### III. CONTROLS

---

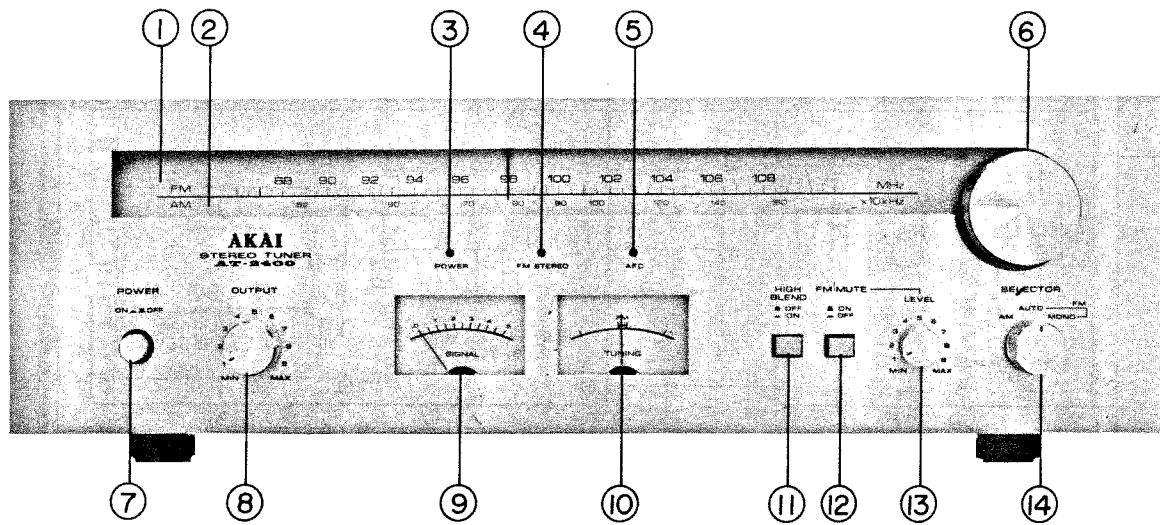

Fig. 1 Controls

- |                             |   |
|-----------------------------|---|
| 1. FM DIAL SCALE            | 8. OUTPUT LEVEL CONTROL                 |
| 2. AM DIAL SCALE            | 9. SIGNAL STRENGTH METER                |
| 3. POWER INDICATOR LAMP     | 10. FM TUNING METER                     |
| 4. FM STEREO INDICATOR LAMP | 11. HIGH BLEND SWITCH                   |
| 5. AFC INDICATOR LAMP       | 12. FM MUTE SWITCH                      |
| 6. TUNING KNOB              | 13. FM MUTE LEVEL ADJUSTER              |
| 7. POWER SWITCH             | 14. INPUT SELECTOR AM, FM AUTO, FM MONO |

# IV. PRINCIPAL PARTS LOCATIONS

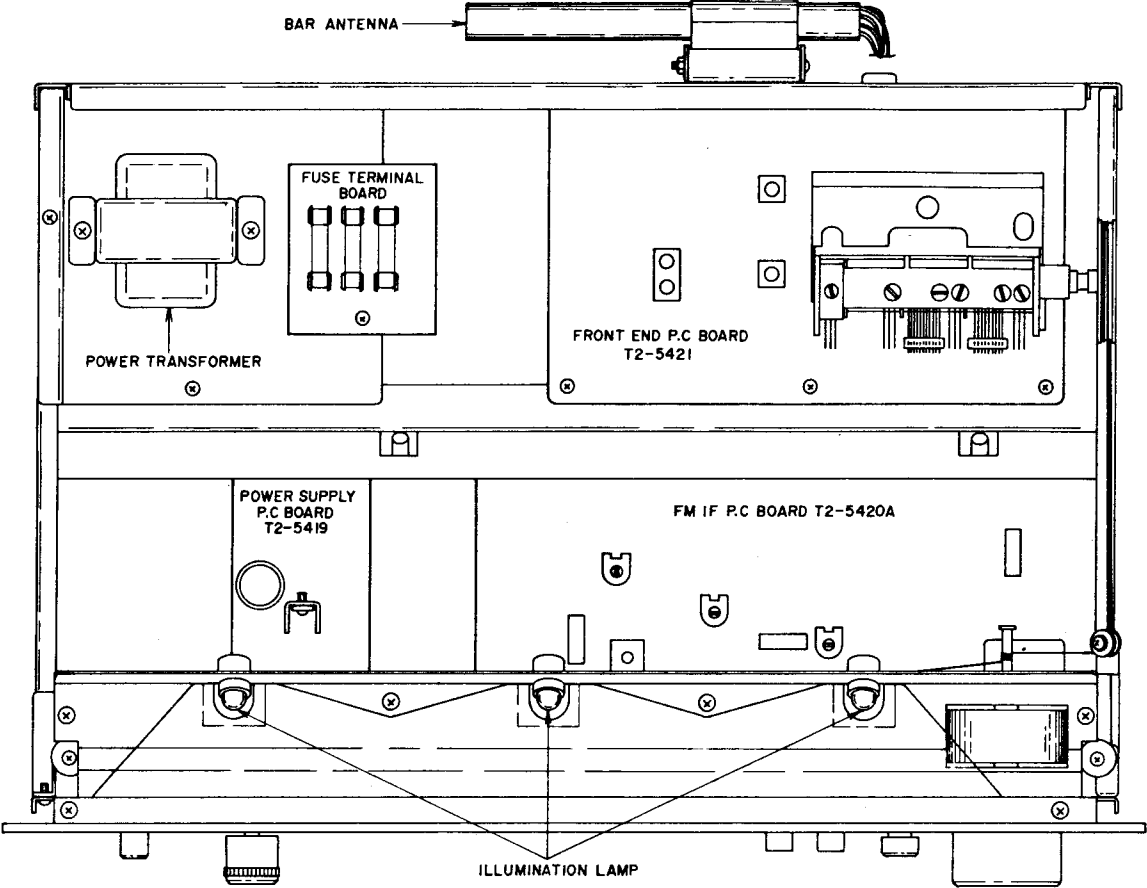

Fig. 2 Top View

# V. OPERATING PRINCIPLES OF QUADRATURE DETECTION SYSTEM

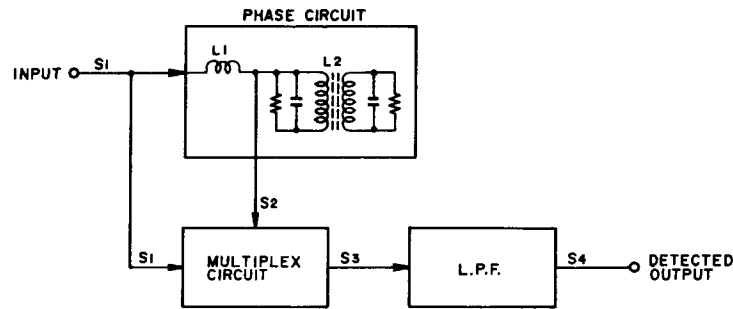

Fig. 3 Quadrature Detection Block Diagram

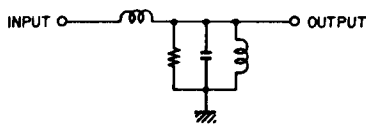

Fig. 4 Single Tuning Type

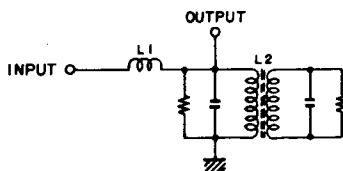

Fig. 5 Double Tuning Type

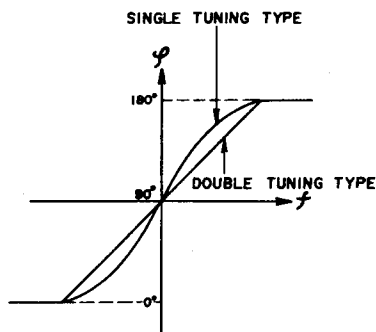

Fig. 6 Tuning Curve

The Quadrature Detection Circuit is comprised of a Phase Circuit, a Multiplier Circuit and a Low Pass Filter (L.P.F.) as shown in Fig. 3.

There are two types of Phase Circuits, the Single tuning type shown in Fig. 4 and the Double tuning type shown in Fig. 5. However, because with the double tuning type there is less frequency deviation in relation to carrier frequency, linearity is improved as shown in Fig. 6, and phase distortion is reduced this type phase circuit is employed in the AT-2400.

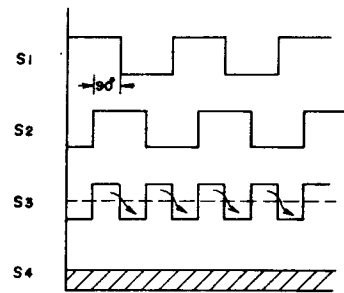

Fig. 7 Output at Non-modulation

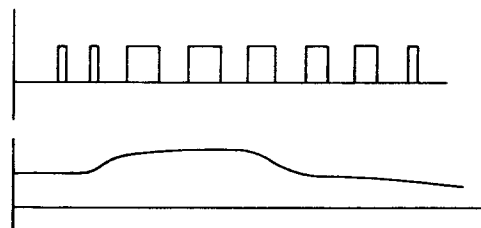

Fig. 8 Output at Modulation Time

Input signal S1 is divided into the part which enters the direct multiplier circuit and the part which passes the phase circuit and enters the multiplier circuit. The signal supplied to the phase circuit is always  $90^\circ$  phase delayed at L1. Also because at Non-modulation time, L2 is tuned to 10.7 MHz, if modulation is applied and S1 is changed from 10.7 MHz, phase deviation at L2 will take place proportionately in relation to this changed part and this becomes S2 signal which is delayed in relation to S1.

At Non-modulation, because as shown in Fig. 7, input signal S1 and  $90^\circ$  phase delayed (by means of L1) signal S2 are switched by means of the multiplier circuit, the output signal becomes S3.

Because this S3 passes the low pass filter and becomes S4 fixed direct current, the detector output is zero.

Then, when modulation is applied, because the switched output is varied according to the degree of modulation, and the output which passed the low pass filter becomes the pulsating current part as shown in Fig. 8, detector output is obtained.

## VI. OPERATING PRINCIPLES OF PLL CIRCUIT EMPLOYED IN STEREO DEMODULATION CIRCUIT

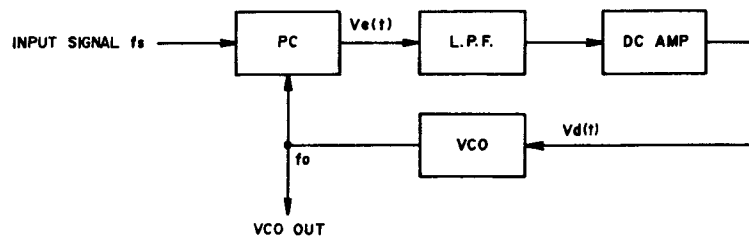

Fig. 9 PLL Circuit

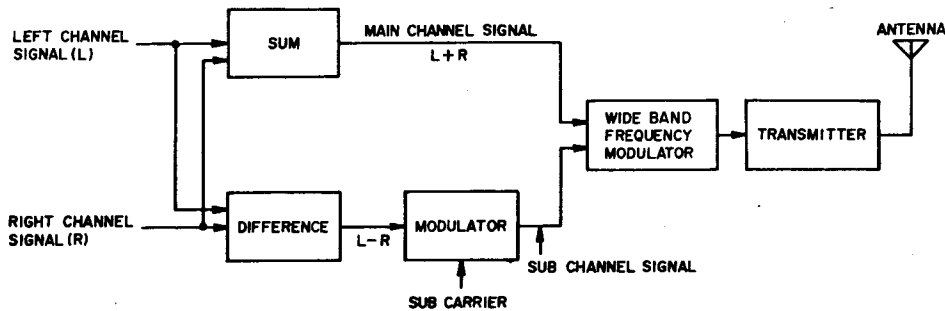

Fig. 10 FM Broadcasting System Diagram

To separate FM stereo broadcast signal received to data into left and right signals, a 19 kHz pilot signal was successively multiplied to form a 38 kHz signal and stereo separation was effected from this. However, with this multiplier system, change in coils due to wear occurred and adjustment points were numerous, etc. Therefore, this model employs a newly developed PLL circuit which produces an exceedingly accurate 38 kHz switching signal.

### 1. PLL CIRCUIT OPERATION

PLL circuit is a kind of feedback circuit and is comprised of a Phase Comparator (PC), a Low Pass Filter (LPF), a Direct Current Amplifier (DC Amp), and a Voltage Control Oscillator (VCO) as shown in Fig. 9. The PC compares input signal  $F_s$  and VCO oscillator output and generates the difference in signal voltage  $V_e(t)$  proportionately to this phase deviation. This  $V_e(t)$  passes LPF and the DC Amp. and becomes control voltage. This control voltage supplied to VCO and VCO oscillation frequency is DC controlled. When there is no input signal  $F_s$ , because there is also no  $V_e(t)$ , control voltage  $V_d(t)$  becomes zero, and VCO maintains a \* free-running oscillation frequency. When a signal enters, VCO oscillation frequency  $F_o$  is controlled to narrow the difference between  $F_s$  by means of feedback as described above, and the PLL circuit assumes a synchronous condition. This is referred to as input signal lock. (In case the difference between  $F_o$  and  $F_s$  is too large, the differential signal frequency becomes high and is reduced at the LPF.

However, because the VCO control voltage does not change, PLL will not stay within the \* lock range). Because of the ability of the signal interference removing LPF to accumulate the previous voltage in case the PLL deviates from within the lock range due to certain interference, the original condition is quickly reinstated.

\* Free running frequency: Oscillating frequency when there is no input signal.

\* Lock range: At the condition in which the VCO oscillation frequency is locked to the input signal, the lock range is the oscillating frequency in which when the input signal changes, the PLL maintains it's input signal lock condition. Accordingly, in case  $F_s$  is changed inside the PLL lock range, VCO oscillation frequency always follows this, and a no frequency deviation and no phase difference signal is obtained. In other words, VCO oscillation frequency can be locked to  $F_s$ .

### 2. STEREO DEMODULATION CIRCUIT

As shown in Fig. 10, for FM broadcasts, the sum signal (L+R) consists of left signal (L) and right signal (R) and the audio frequency band of this signal in its original form is frequency modulated.

On the other hand, the difference signal of both (L-R) is changed to high frequency through the use of the sub carrier, and is referred to as the sub channel signal. The carrier is further frequency modulated and sent to the FM stereo transmitter.



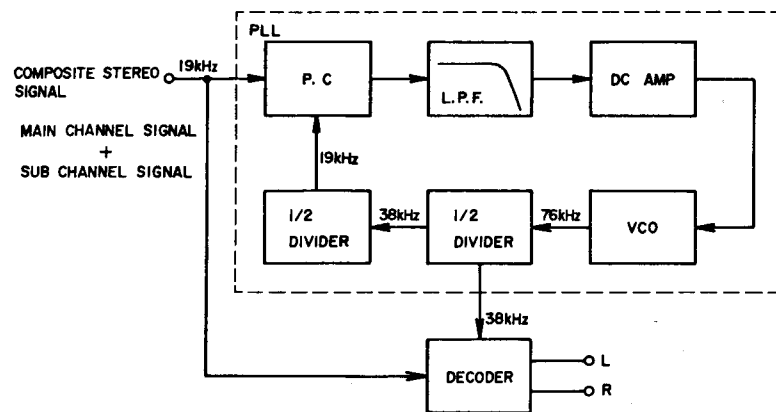

Fig. 11 MPX IC Function

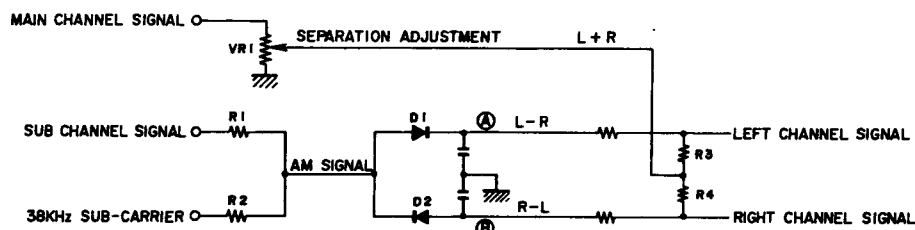

Fig. 12 Multiplex Decoder

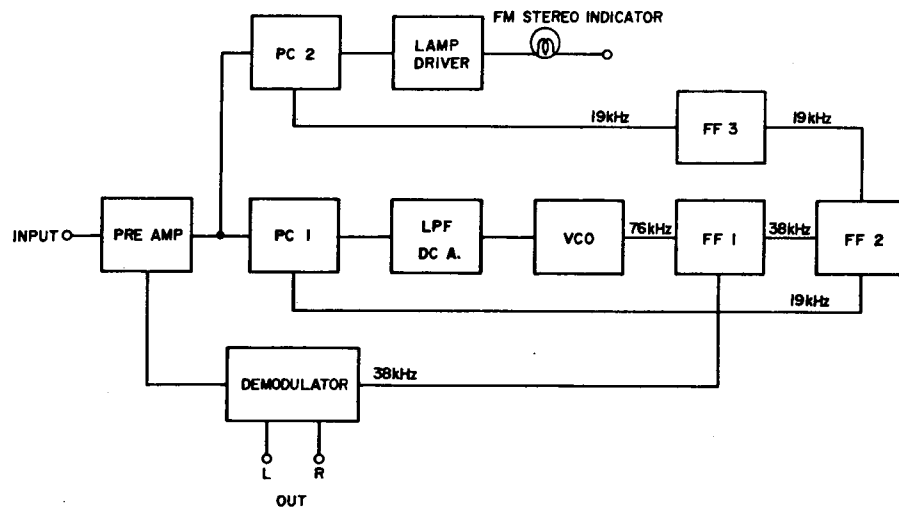

Fig. 13 LA-3350 Function System Diagram

Accordingly, for composite stereo signal demodulation, the sub carrier used for demodulation at the transmitter must be the same uniform 38 kHz signal as the frequency and phase. If the 38 kHz waveform is asymmetrical, channel separation will become poor. At the PLL employed MPX stereo demodulator circuit, as shown in Fig. 9, first a 76 kHz signal is oscillated and when this passes the divider, a symmetrical 38 kHz signal is obtained.

This 38 kHz sub carrier is supplied to the multiplex decoder together with the sub channel of the composite stereo signal. At the multiplex decoder, left and right channel audio signals are separated in order as shown in Fig. 12.

The 38 kHz sub carrier composited with the sub channel signal of which the carrier part was removed

when sub channel signal and sub carrier passed R1, R2 produces the regular AM wave. Then, because this envelope is detected by mutually reverse polarity connected diodes D1 and D2, L-R signal is emitted at point A and R-L signal at point B.

Also, because main channel signal (L+R) is supplied to R3, R4 center point, A B point voltage is added and subtracted and becomes

$$(L+R) + (L-R) = 2L \text{ (left channel)}$$

$$(L+R) + (R-L) = 2R \text{ (right channel)}$$

The level of the main channel signal (L+R) can be adjusted by means of variable resistor VR (VR1) for optimum separation.

Thus, the function of actually employed PLL IC LA-3350 is a shown in Fig. 13.

# VII. TUNER SECTION ADJUSTMENT

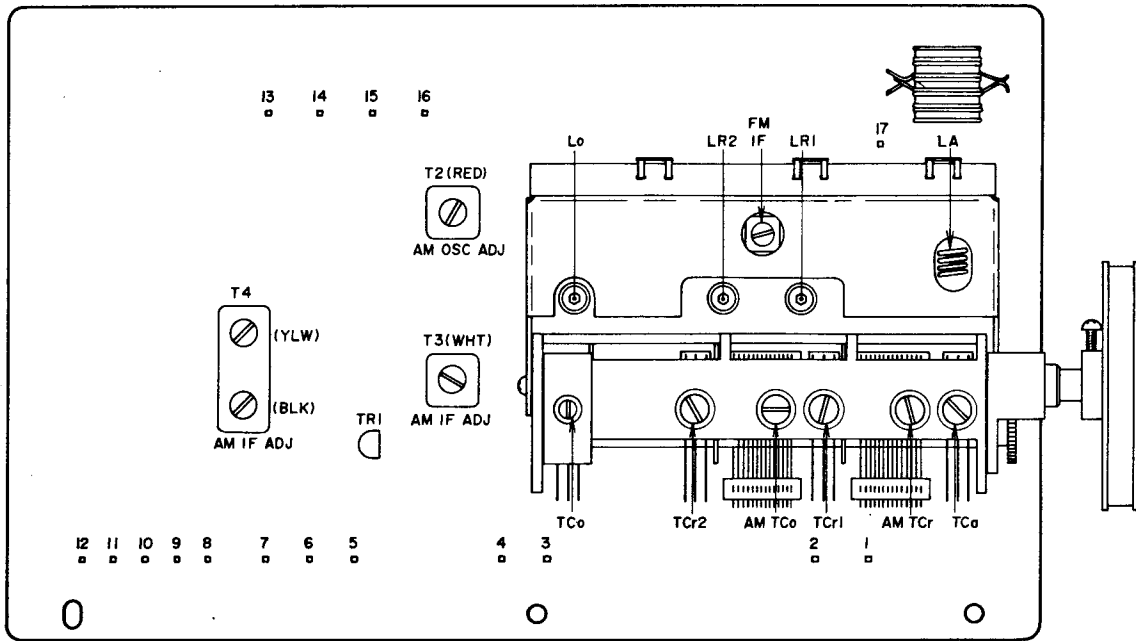

Fig. 14 Front End P.C Board T2-5421

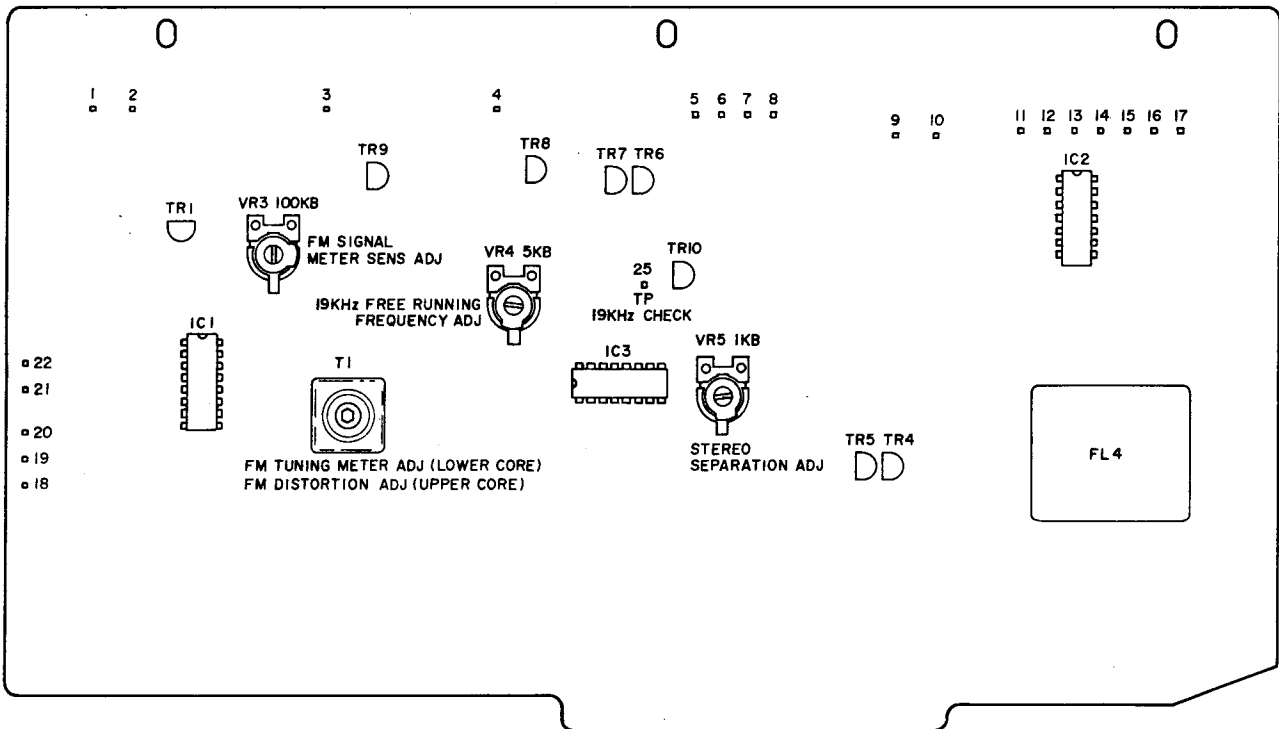

Fig. 15 FM IF P.C Board T2-5420A

## 1. FM TUNER SECTION ADJUSTMENT (Refer to Fig. 14 and 15)

Step	Adjustment Item	Adjustment Part	Result	Remarks
1	Front End IF Coil	IF Coil (Front End)	Maximum Noise Level	Set Selector to FM. Set FM Mute to OFF. Tune only noise without interference of broadcasting.
2	Tuning Meter centering	T-1 Lower side core (FM IF P.C Board)	Center indication of tuning meter	Same as above
3	Distortion factor adjustment	T-1 Upper side core	Less than 0.2% distortion factor	108 MHz, 60 dB (MONO) input. Less than 0.2% on both channels.
4	Confirmation of tuning meter indication			If tuning meter indication is not at center position, repeat Step-2, Step-3 above.
5	Frequency Coverage Adjustment	TCo (High range) Lo (Low range) (Front End)	error: within $\pm 250$ kHz	108 MHz, 88 MHz, 60 dB (MONO) input.
6	Sensitivity Adjustment	TCr, TCa (High range) Lr, La (Low range) (Front end)	Less than 3% distortion factor	108 MHz, 88 MHz, Less than 10 dB (MONO) input.
7	PLL IC Free Running Frequency Adjustment	VR4 5 kB (FM IF P.C Board)	19.00 kHz	FM Mute switch to "ON", Frequency counter to pin 25. (FM IF P.C Board)
8	Stereo Indicator Lighting Confirmation			98 MHz, 60 dB (stereo) input Failure of stereo indicator to light means that stereo broadcasts are not being received.
9	Stereo separation Adjustment	VR5 1 kB (FM IF P.C Board)	More than 42 dB	98 MHz, 60 dB (stereo) L ch input. Distortion factor must be less than 0.3%.
10	Stereo Separation Adjustment		More than 42 dB	98 MHz, 60 dB (stereo), R ch input. Distortion factor must be less than 0.3%, and if it exceeds 0.3%, adjust the coil in STEP-1 within half a turn.
11	Signal Meter Indication adjustment	VR-3 100 kB (FM IF P.C Board)	Needle Indicates "4.8" on scale	98 MHz, 100 dB (MONO) input.
12	Confirmation of tuning meter indication		Center indication of tuning meter	

Note-1 In the event that the distortion factor in STEP-6 is not less than 3%, re-adjust Front End Trimmers TCr, TCa, Lr, & La to obtain a minimum average distortion factor at 88, 98 & 108 MHz. (same distortion factor at all 3 points).

Note-2 Free running frequency of the PLL IC must be an exact 19.00 kHz.

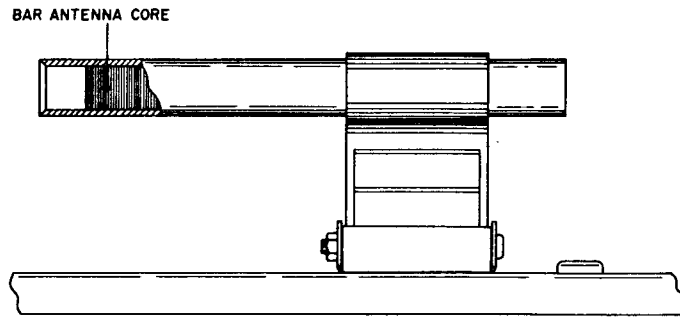

Fig. 16 Bar Antenna

## 2. AM TUNER SECTION ADJUSTMENT (Refer to Fig. 15 and 16)

Step	Adjustment Item	Adjustment Part	Result	Remarks
1	Low range frequency coverage	T-2 (red) (Front End P.C Board)	Error: within 2%	Set selector to AM. 520 kHz optional input.
2	Low range sensitivity	Bar antenna core, T-4 (YLW, BLK) T-3 (WHT) (Front End P.C Board)	Maximum Sensitivity	520 kHz optional input.
3	High range frequency coverage	AM TCo Trimmer Condenser (Front End)	Error: within 2%	1,400 kHz optional input.
4	High range sensitivity	AM TCr Trimmer Condenser (Front End)	Maximum Sensitivity	1,400 kHz optional input.
5	Scale and sensitivity confirmation			Repeat Steps 1 through 4 two or three times.

# VIII. TUNING CORD THREADING

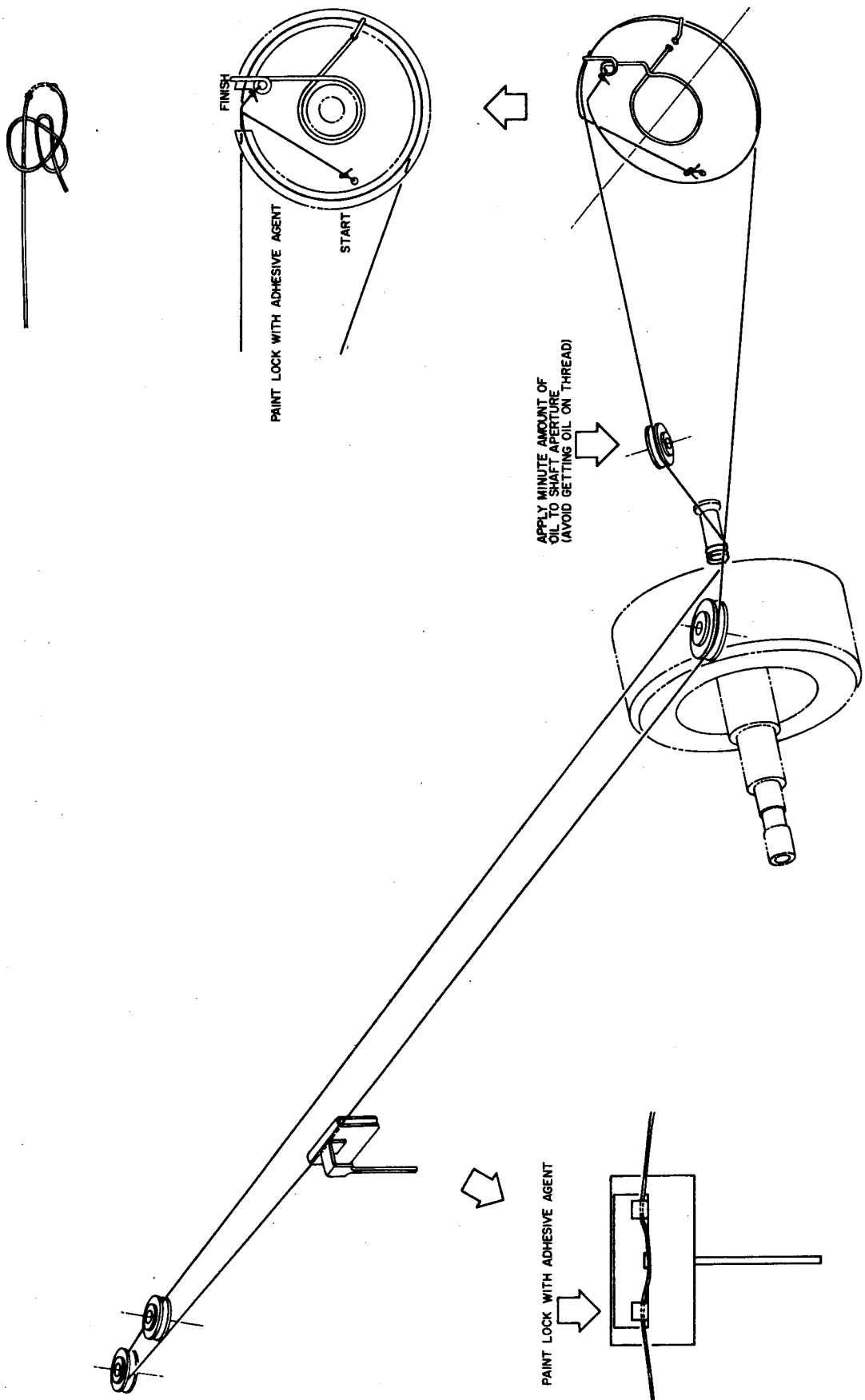
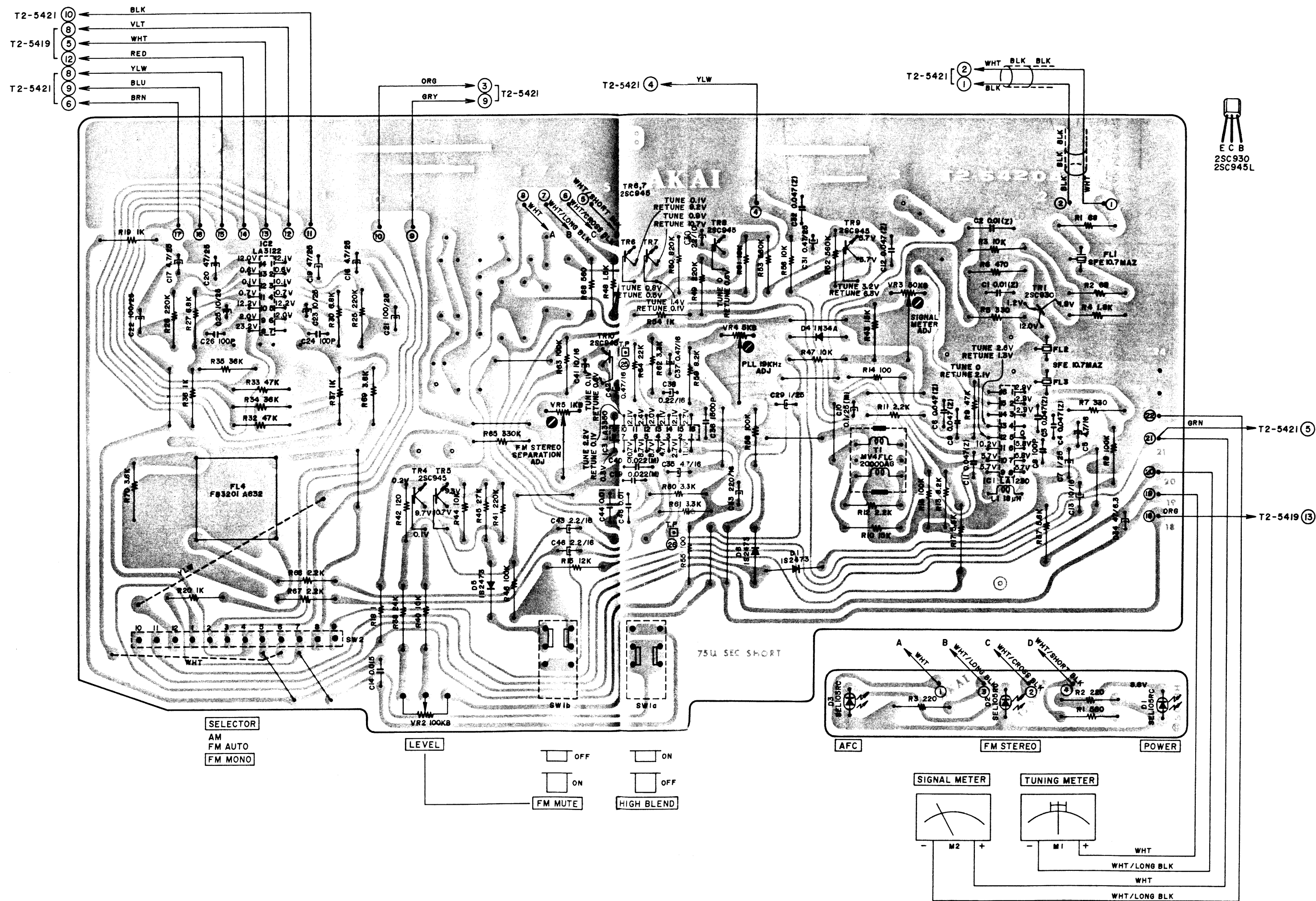

Fig. 17 Tuning Cord Threading

# IX. COMPOSITION OF P.C BOARDS

## 1. FM IF P.C BOARD T2-5420A, LED P.C BOARD T2-5420B



## 2. FRONT END P.C BOARD T2-5421

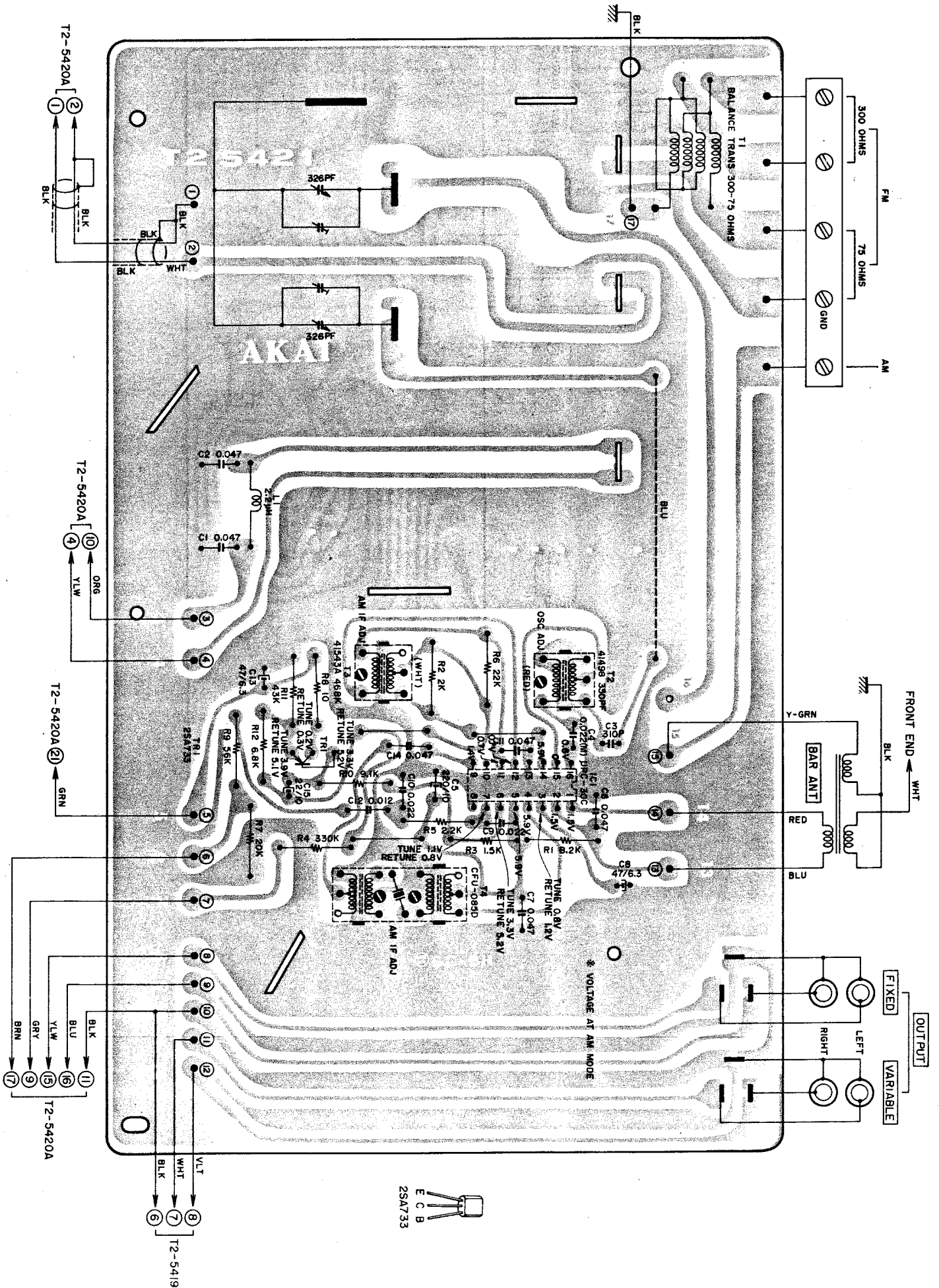





---

SECTION 3

**SCHEMATIC DIAGRAM**

1. AT-2400 NO. 2-1 1540446A SCHEMATIC DIAGRAM
2. AT-2400 NO. 2-2 1540447A FRONT END FB622U11

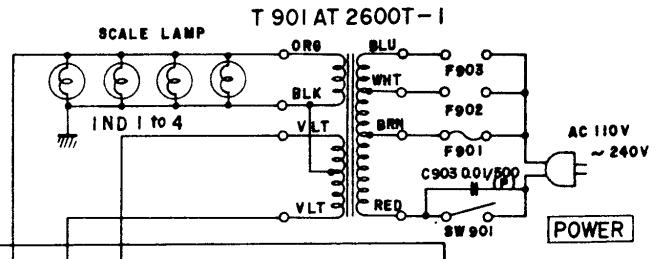
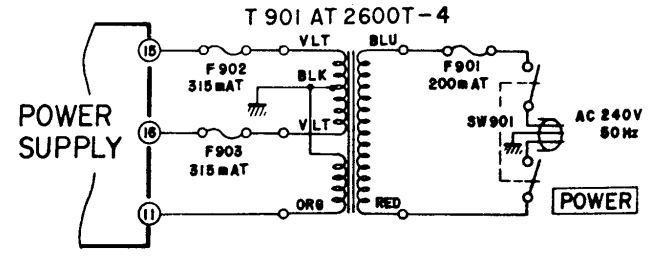
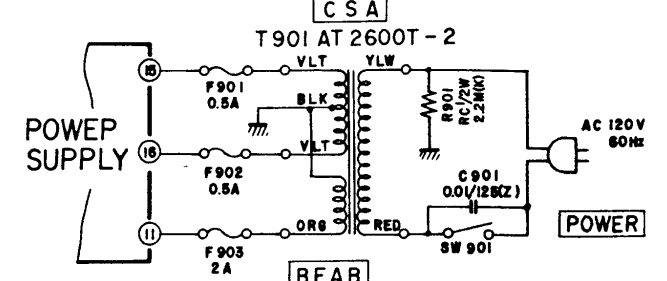
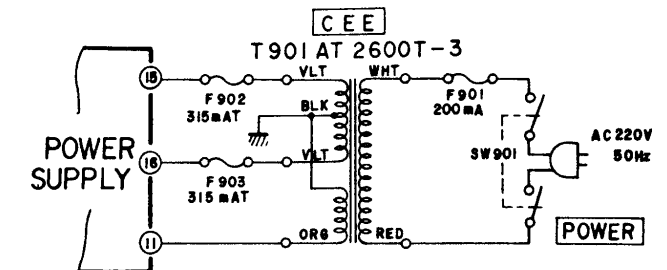
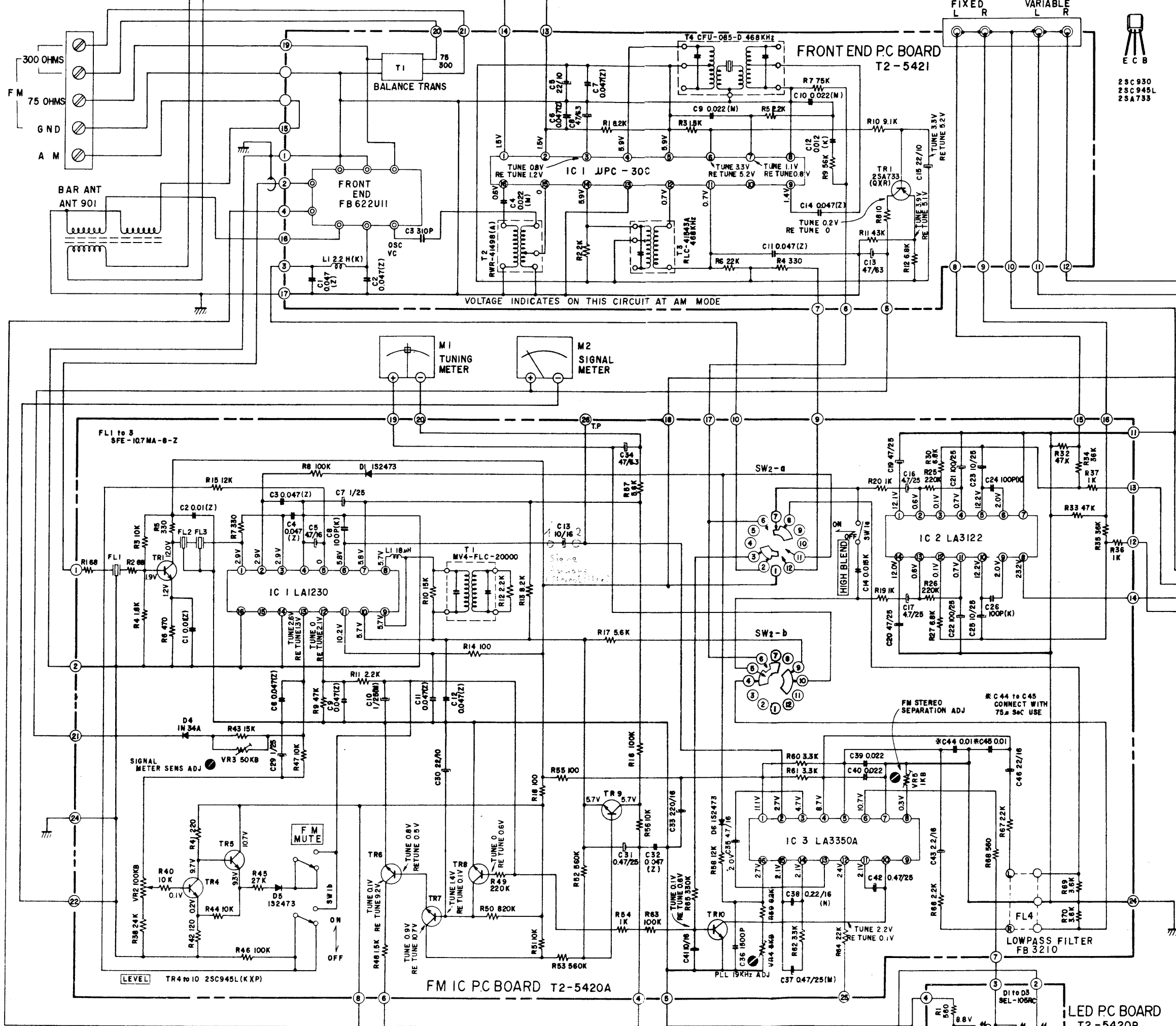

USE  
 F901 0.5A 100V ARER  
 F902 0.25A 200V ARER  
 (F903)

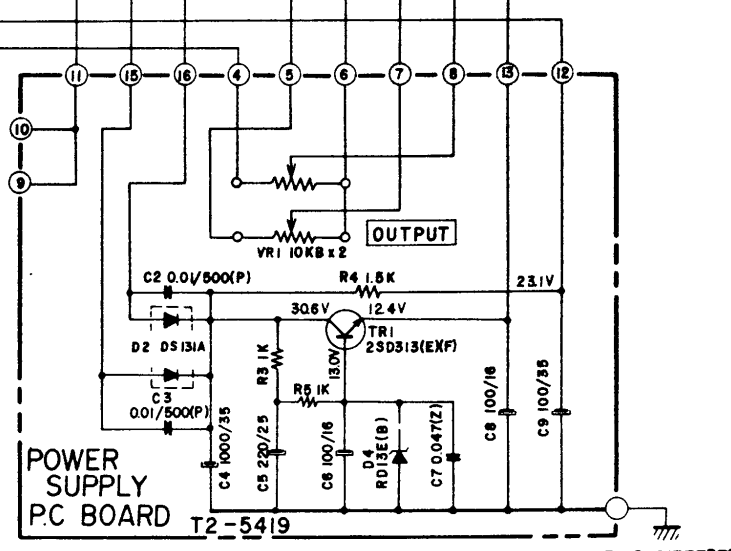

NOTE 1. UNLESS OTHERWISE SPECIFIED  
 ALL RESISTORS IN OHMS 1/4 W(J)  
 ALL CAPACITORS IN μF 50 WV (J)  
 P = μMUF

2. POWER TRANSFORMER IS DIFFERENT  
 ACCORDING TO AREA

AT-2400

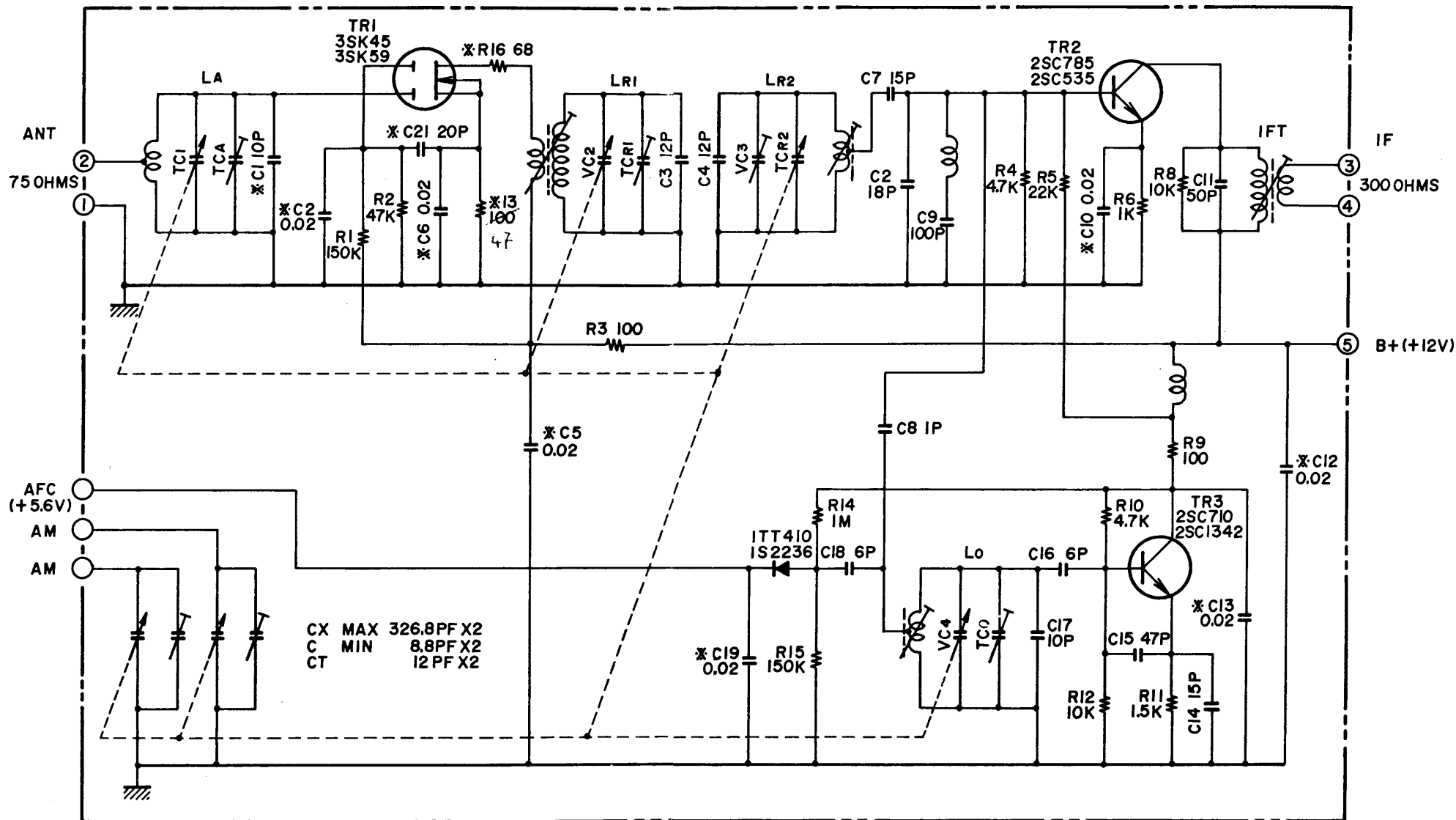

AT-2400  
 FRONT END FB622U11  
 NO. 2-2 1540447A