

172

SERVICE MANUAL

AKAI TAPE RECORDER

MODEL **EX-365**

REPAIRABLE BY MODEL EX-365D



TABLE OF CONTENTS

I	SPECIFICATIONS	2
II	MEASURING METHODS	3
III	CONTROL LOCATIONS	5
IV	DISMANTLING OF TAPE TRANSPORT UNIT & AMPLIFIERS	6
V	MAGNETIC HEADS ADJUSTMENT	8
VI	AMPLIFIER ADJUSTMENT	9
VII	MECHANISM ADJUSTMENT	12
VIII	TRANSPORT MECHANISM	17
IX	MAINTENANCE PROCEDURES	24
X	TROUBLE SHOOTING CHART	25
XI	COMPOSITE VIEWS OF COMPONENTS	29
XII	SCHEMATIC DIAGRAM	

When placing order for parts, please use separate
PARTS LIST or PRICE LIST FOR PARTS.

I. SPECIFICATIONS

POWER SUPPLY	: AC 100 to 240 V, 50 or 60 Hz	MAIN MOTOR	: Hysteresis Synchronous 3 speeds (2-4-8 pole) motor. Condenser Capacity 3 μ F (50 Hz), 2 μ F (60 Hz) Revolutions : 3,000-1,500-750 r.p.m. (50 Hz) 3,600-1,800-900 r.p.m. (60 Hz)
RECORDING SYSTEM	: In-line 4-track stereo/monaural Focused Field Recording System	REEL MOTOR	: Two 6-pole eddy current outer-rotor motors Revolutions : 930 r.p.m. at 50 Hz, 100 V 1,120 r.p.m. at 60 Hz, 120 V
TAPE SPEED	: 1-7/8, 3-3/4, 7-1/2 and 15 ips.	HEADS	
TAPE SPEED DEVIATION	: Within $\pm 0.5\%$ at 7-1/2 ips within $\pm 1.0\%$ at 3-3/4 ips Within $\pm 1.0\%$ at 1-7/8 ips	PLAYBACK HEAD	: In-line 4-track stereo/monaural, Glass + Crystal Ferrite Head Impedance . . . 2,500 ohms at 1,000 Hz Gap . . . 2 microns
WOW AND FLUTTER	: Less than 0.10% r.m.s. at 7-1/2 ips Less than 0.13% r.m.s. at 3-3/4 ips Less than 0.25% r.m.s. at 1-7/8 ips	RECORDING HEAD	: In-line 4-track stereo/monaural, Glass + Crystal Ferrite Head Impedance . . . 15 ohms at 1,000 Hz Gap . . . 4 microns
FREQUENCY RESPONSE	: 30 to 22,000 Hz ± 3 dB at 7-1/2 ips 30 to 18,000 Hz ± 3 dB at 3-3/4 ips (30 to 23,000 Hz ± 3 dB using SRT Tape) 40 to 9,000 Hz ± 4 dB at 1-7/8 ips	ERASE HEAD	: In-line 4-track stereo and monaural Impedance . . . 380 ohms at 100 KHz Gap . . . 0.4 mm
SIGNAL TO NOISE RATIO	(at Line Output) : Greater than 48 dB at 7-1/2 ips Greater than 45 dB at 3-3/4 ips Greater than 48 dB at 1-7/8 ips	INTERNAL SPEAKERS	: 2 4-inch Round Speakers Nominal Power Input . . . 3 W, 16 ohms
TOTAL HARMONIC DISTORTION	(at Line Output, 1,000 Hz 0 VU Rec/PB) : Within 1.7% at 7-1/2 ips Within 3.0% at 3-3/4 ips Within 3.0% at 1-7/8 ips	TRANSISTORS USED	: 12 2SC458LG (C) 8 2SC454 2 2SC971 (2) (3) (Red) 2 2SC538 (4) (R) 4 2SC1014 4 2SD234 6 2SC711E 5 2SC711D 3 CDC9000-1 (B) (C) 4 2SC458LG (B) (C) 4 2SC458LG (B) 4 2SC968 1 2SC372 (F)
RECORDING INPUTS		DIODE USED	: 1 2SC728 11 IN34A 1 10D1 13 10D4 1 10D6 1 5B2 4 SL-150 1 IN759A 1 RD-24A 1 RD-9A
MICROPHONE	: Above 0.7 mV		
LINE INPUT	: Above 70 mV Impedance . . . 166 K ohms		
DIN INPUT	: High : 70 mV 166 K ohms Low : 7 mV 16 K ohms		
OUTPUTS			
LINE OUTPUT	: Required Load Impedance : more than 50,000 ohms 1.23 V (+4 dBs ± 1.5 dB) at 7-1/2 ips 1.03 V (+2.5 dBs ± 1.5 dB) at 3-3/4 ips 0.82 V (+0.5 dBs ± 1.5 dB) at 1-7/8 ips		
POWER OUTPUT	: External Speaker Jack More than 10 W at 8 ohms Non-inductive resistance		
NOISE	: Less than 5 mV at 8 ohms at External Speaker Jack (Volume Control at "Minimum" position)		
FAST FORWARD AND REWIND TIME	: 85 seconds for a full 1,200 foot tape at 50 Hz 70 seconds for a full 1,200 foot tape at 60 Hz		
CROSS-TALK	: Less than -70 dB (Monaural) Less than -45 dB (Stereo)		
ERASE RATIO	: More than 70 dB		
INSULATION DURABILITY	: 500 V AC for more than one minute duration		
BIAS FREQUENCY	: 100 KHz to 110 KHz		

II. MEASURING METHOD

TAPE SPEED DEVIATION

1. Method involving use of pre-recorded tape.
Playback a tape pre-recorded at 1,000 Hz ($\pm 0.1\%$) on recorder to be tested. Connect the appropriate output to a frequency counter meter in order to measure the tape speed deviation.

2. Method involving use of timing tape
(designed for tape speed measurement)

This method utilizes a timing tape marked at intervals of $7\frac{1}{2}$ ". The running time of over 60 marked sections of tape is measured in order to calculate the deviation of the tape speed. In applying this method, however, it should be kept in mind that timing tape stretch or contract measurement error is inevitable, so that it is necessary to measure the total length of the tape in advance.

WOW AND FLUTTER

Playback a 3,000 Hz pre-recorded tape of which the wow and flutter level is guaranteed to be smaller than 0.07% for measurement by means of a wow meter. It is also possible for a 3,000 Hz sine wave to be recorded and played back for measurement by means of the wow meter. In this case, however, the wow meter indicates a value as much as twice the value given in the specifications.

FREQUENCY RESPONSE

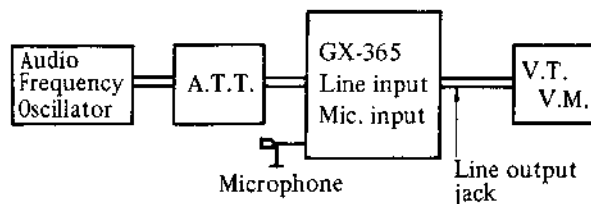

Connect the measuring instrument as in the above diagram, and measure the frequency response according to following sequence :

RECORD :

- 1) Introduce a sine wave of 1,000 Hz to the Line Input of the recorder to be tested, through an attenuator from an audio frequency generator.
- 2) Set Recorder to Recording Mode and adjust the line input volume so that the VU meter needle indicates "0" VU.
- 3) Under the condition described in (2), lower the input level 15 dB by means of the attenuator.
- 4) Record Spot frequencies in the range of 30 Hz to 25,000 Hz from the audio frequency generator.

PLAYBACK :

- 5) Connect a V.T.V.M. to Line Output.
- 6) Playback the tape previously recorded.
- 7) Adjust the output level to "0" dbm at 1,000 Hz (indicated on range selector of V.T.V.M.).
- 8) Playback the recorded spot frequencies, make a memo of output level, and plot the value on a graph.

TOTAL HARMONIC DISTORTION FACTOR

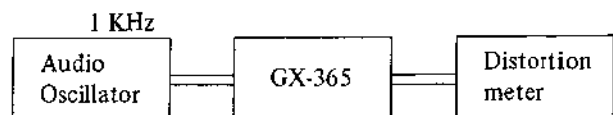

Connect the measuring instrument as shown above, and record a 1,000 Hz sine wave at "0" VU. Playback the resultant signal and measure the overall distortion factor. Measure the noise level of the tape recorder with the tape removed ; connect the audio oscillator directly to the distortion meter for measurement of the distortion factor of the oscillator.

The required distortion factor can be obtained from the results of the above measurement by the following formula :

$$d_0 = d - d_1 - d_2$$

where, d_0 = Required
 d = Overall distortion factor
 d_1 = Noise level
 d_2 = Distortion factor of the oscillator

(Note : New tape of particularly good quality should be used for measurement of the distortion factor).

SIGNAL TO NOISE RATIO

Playback a tape containing a 250 Hz sine wave recorded at "0" VU level on a standard recorder. Connect a high sensitivity V.T.V.M. to the line output jack and measure its output.

Then remove the tape and measure the noise level under the same conditions. Convert each of the measured values into decibels.

POWER OUTPUT

Playback a tape containing a sine wave of 1,000 Hz recorded at 0 VU on a standard recorder. Measure the voltage at the output of the recorder to be tested when terminated with 8 ohms resistance. Then use the following formula :

$$P = \frac{E^2}{R} \quad \left\{ \begin{array}{l} P = \text{Desired output (watts)} \\ E = \text{Measured voltage (R.M.S.)} \\ R = 8 \end{array} \right.$$

CROSS TALK (Cross talk between the tracks)

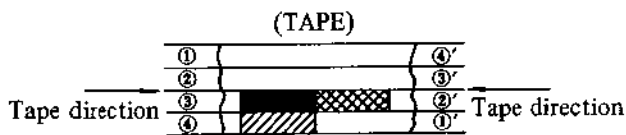

As shown in the figure, first record a 1,000 Hz sine wave on track No. 3 at +3 VU level. Next, remove the 1,000 Hz input signal and record under a non-input condition. Then, playback the tape on track No. 3 and No. 1 (reversed condition of tape) through the 1,000 Hz B.P.F. (Band Pass Filter, Sensitivity . . . 1 : 1) and obtain a ratio between the two from the following formula.

$$C = 20 \log \frac{E_0}{E_2 - E_1} \text{ (db)}$$

C = Desired cross talk ratio (db)
 E₀ = 1,000 Hz signal output level
 E₂ = 1,000 Hz cross talk output level
 E₁ = Non-input signal record level



III. CONTROL LOCATIONS

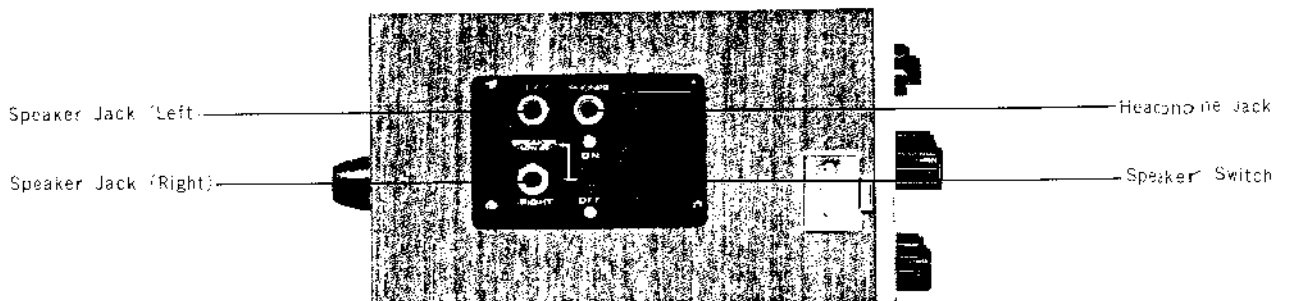
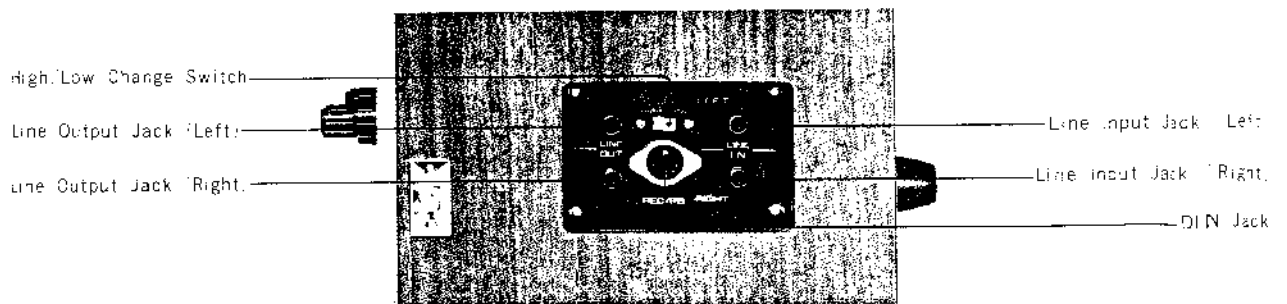
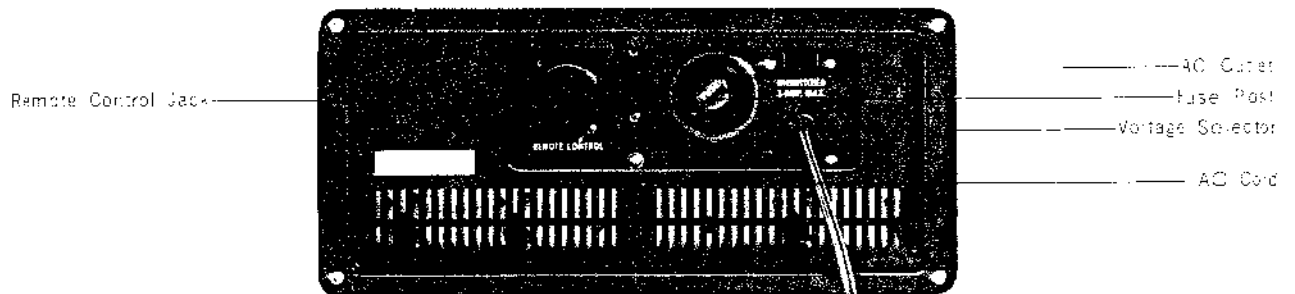

IV. DISMANTLING OF TAPE TRANSPORT UNITS & AMPLIFIERS

In case of trouble, etc. necessitating disassembly, please disassemble in the order shown in photographs. Re-assemble in reverse order.

4

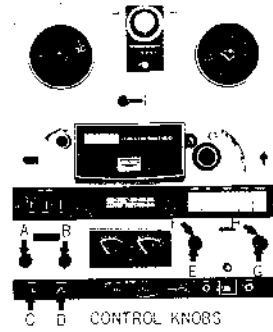

1

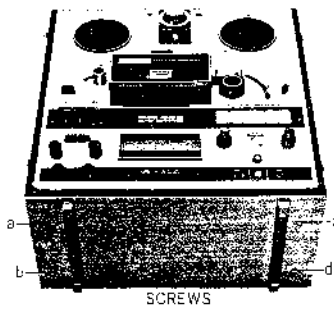

5

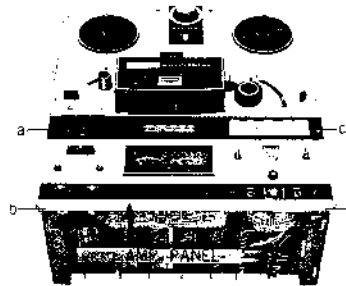

2

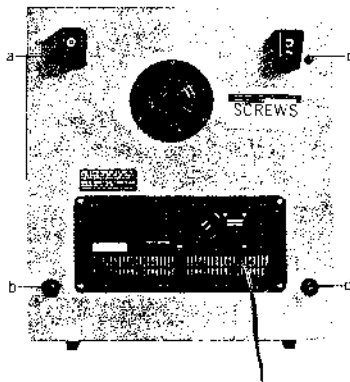

6

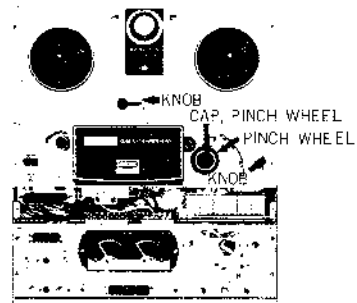

3

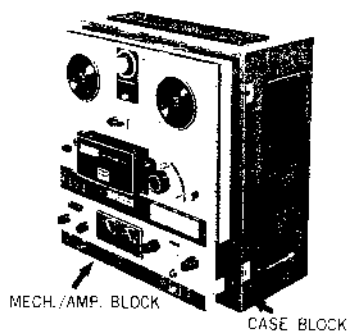

7

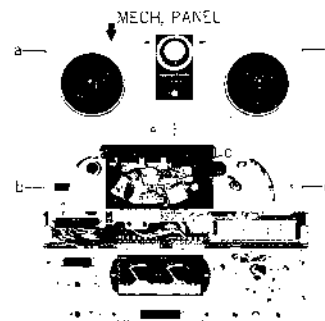

8

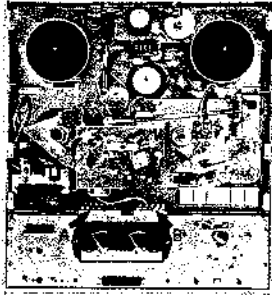

CONNECTION PLUGS

12

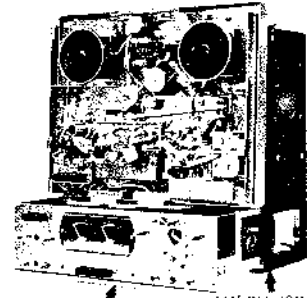

AMP. BLOCK MLCH (SP) BLOCK

9

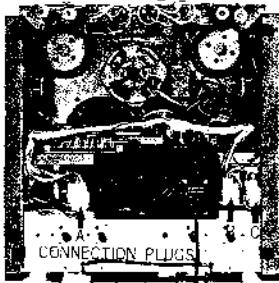

CONNECTION PLUGS

13

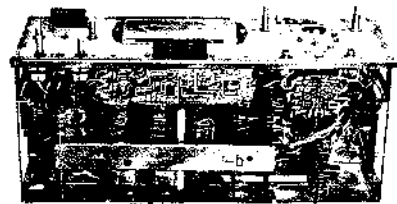

SUPPORTING PLATE

10

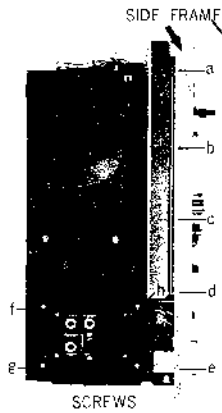

SCREWS

14

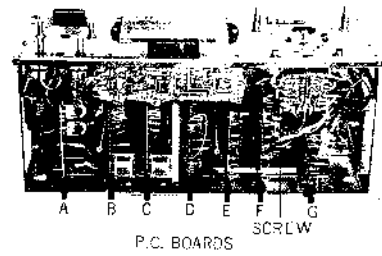

P.C. BOARDS SCRLW

11

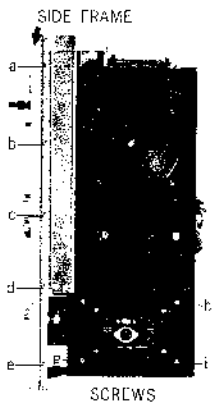

SCRLWS

15

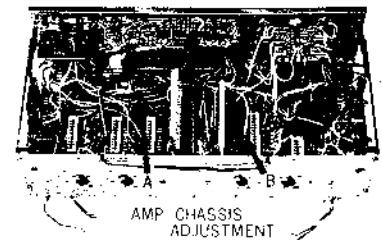

AMP CHASSIS ADJUSTMENT

V. MAGNETIC HEADS ADJUSTMENT

1. Adjustment of Magnetic Heads

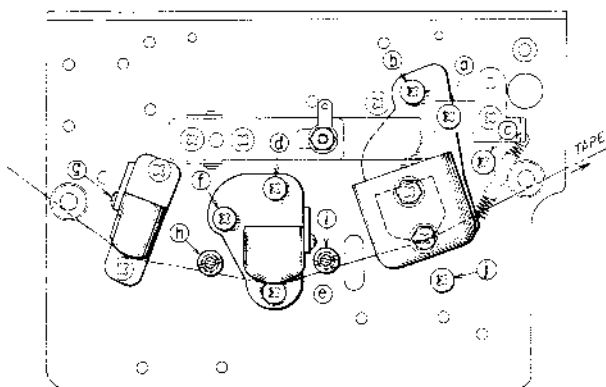

Fig. 1

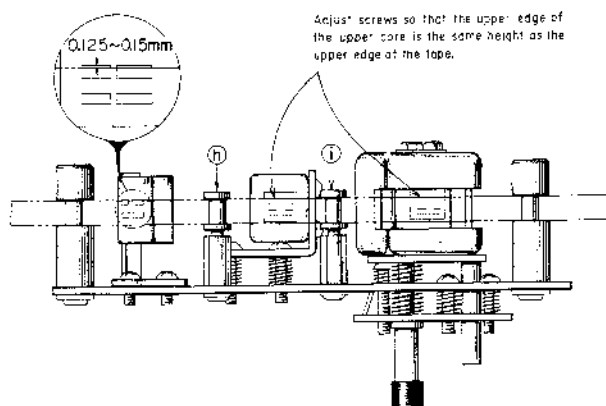

Fig. 2

As head adjustments critically affect tape recorder performance, it is essential that the heads be carefully adjusted with precision measuring equipment and a suitable recorded tape.

1.1 Adjustment of Head Height (See Figures 1 and 2)

When replacing the Head Assembly, adjust Tape Guides (J) and (K) so that they do not contact the edge of the tape, then proceed with head height adjustments as follows.

1) Playback Head

During "normal play", adjust playback head height by turning head height control screw (a) (Figure 1) until the upper edge of the tape as it passes the head is aligned with the top edge of CH-1 playback head core.

During "reverse play", turn head height control screw (b) (Figure 1) until the lower edge of the tape is aligned with the bottom edge of CH-1 playback head core.

2) Recording Head

Adjust the recording head height by turning head height control screws (d), (e), and (f) (Figure 1) until the upper edge of the tape as it passes the head is aligned with the top edge of CH-1 recording head core.

3) Erase Head

Adjust the erase head height by turning head height control screws (g), (h), and (i) until the upper edge of the tape as it passes the head is from 0.125 to 0.15 mm lower than the top edge of the CH-1 erase head core.

Note: When making head height adjustments, make sure that the front of the head is at right angles with the chassis and the tape firmly contacts both the upper and lower part of the head.

1.2 Adjustment of Azimuth Alignment

1) Playback Head

A. Use a pre-recorded tape (16 KHz, 7-1/2 ips), and connect a high sensitivity V.T.V.M. to the line output jack. Adjust screws (c) and (j) until the line output voltage is maximum.

B. At reverse play, make the same adjustment as outlined in (A) above. At both normal and reverse play, adjust so that the difference in output power of both channels is within 1.5 dB.

If screw (j) has been turned, make head height adjustment again.

2) Recording Head

Connect an audio oscillator to the line output jack, depress "Tape" Button, and record a 16 KHz signal at a -10 dB recording level. Adjust screw (f) (Figure 1) so that the indicated V.T.V.M. value applied to the line output jack is maximum.

3) Erase Head

Visually check to confirm that the center line of the erase head is at a right angle with the head chassis.

VI. AMPLIFIER ADJUSTMENT

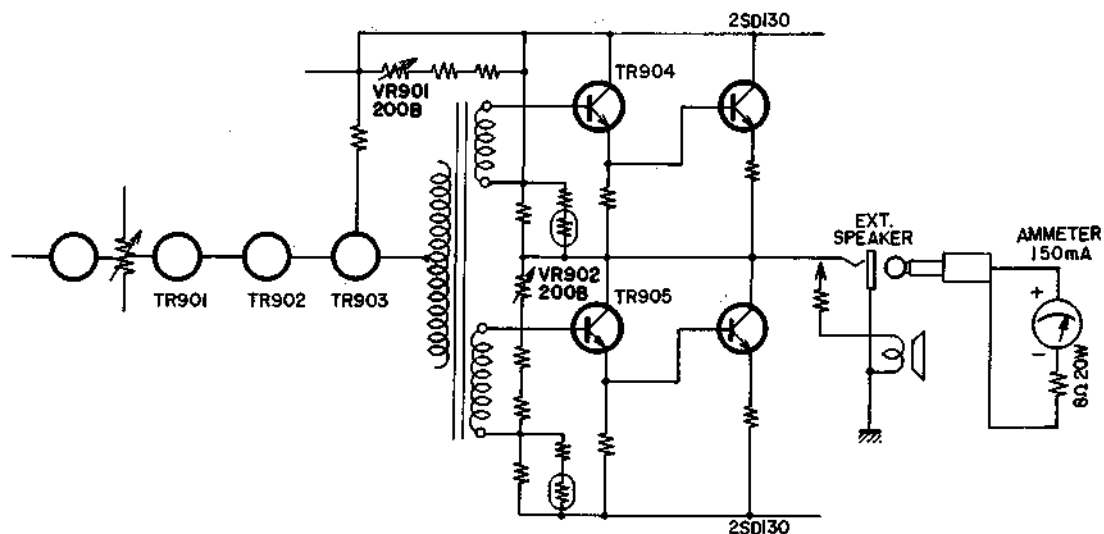

Fig. 1

1. PLAYBACK OUTPUT LEVEL (Pre-amplifier) ADJUSTMENT

- Connect a High-sensitivity V.T.V.M. to the Line Output Jack.
- Set the Tape Speed Selector Switch to "7-1/2".
- Playback a 250 Hz pre-recorded tape.
- Adjust the VR801 (semi-fixed resistor, 50 K-B) of the Pre-amplifier so that Line Output Voltage indicates 1.228 V (+4 dbm).

2. VU METER SENSITIVITY ADJUSTMENT

After the above adjustment, adjust the VR351, 352 (semi-fixed resistor 2 K-B) of Chassis Print Board (RD-526) so that the VU meter needles indicate exactly 0VU, denoted by dot..

3. MAIN AMPLIFIER ADJUSTMENT

- As shown in Fig.1, connect the AM Meter (100 mA-150 mA scale) and a resistor (8Ω 20W) to the External Speaker Jack.
- Set the Main Amplifier Volume Control to minimum so that VR901 and VR902 (semi-fixed resistors 200Ω-B) are wound counterclockwise.
- Turn on Power Switch. Adjust VR901 and VR902 so that the AM meter needle indicates "0".
- The foregoing should accomplish adjustment. After adjustment has been made, Collector Voltage of 2SD234 (Power Output Transistor) should read 26 to 27 V, with Collector Current at 20 to 30 mA.

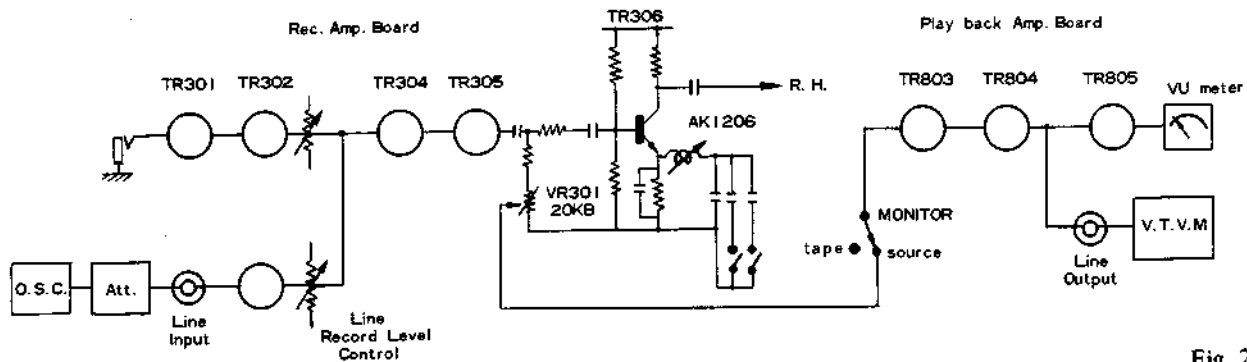

Fig. 2

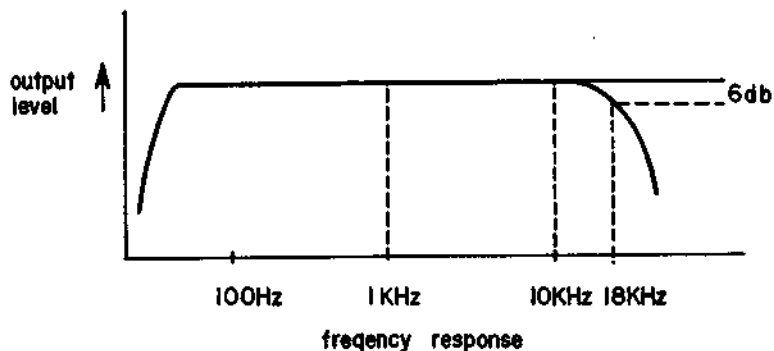

Fig. 3

4. RECORDING AMPLIFIER ADJUSTMENT

Recording Amplifier Adjustment should be made only after Head Adjustment (vertical and horizontal azimuth) and Playback Amplifier Adjustments have been performed.

- Load a blank test tape (Fuji S-100) on the Tape Recorder.
- As shown in Fig. 2, connect an Audio Oscillator and Attenuator to the Line Input. Connect a High-sensitivity V.T.V.M. to the Line Output.
- Set the Tape Speed Selector to "7-1/2" and the Monitor Switch to "TAPE" position.
- With Audio Oscillator, supply a 1,000 Hz signal to Line input. With Forward Button and Record Interlock Button, set recorder to recording mode.
- Adjust the Line Level Control so that the VU meter needle indicates "0" (white dot).
- Depress "SOURCE" button. Adjust the VR301 (semi-fixed resistor 20 K-B) of Recording Amplifier Board (RD-A516) so that the VU meter needle indicates "0" (white dot).

5. RECORDING EQUALIZATION CHARACTERISTICS ADJUSTMENT

- For tape and meters, follow the procedure used for the adjustment of recording amplifier.
- Adjust the recording level control while "Source" Button is depressed. VU Meter needle should indicate "0" VU (white dot).
- Attenuate the Audio Oscillator signal by 20 dB.
- Depress "Tape" Button. At 3-3/4 ips, start recording by depressing Forward and Record buttons.
- As shown in Fig. 3, record the frequencies of 1 KHz and 10 KHz. Adjust the bias voltage so that the V.T.V.M. which is connected to the line output indicates the same voltage at both frequencies.
- At 3-3/4 ips, the bias voltage can be adjusted by turning VR501, 502 (R) (semi-fixed resistor 30 K-B) of Bias Oscillator Board (RD-A513).
- After completion of the foregoing, observe the recording/playback output voltage at 1 KHz and 10 KHz. If this voltage remains constant, continuously change the frequency response of the Audio Oscillator. Check to see that the output voltage is within ± 3 dB at any condition up to 18 KHz.
- After the above adjustments have been made, reset the attenuator dial to read "0" VU. Follow the procedures as detailed in 4 (e) and (f), and readjust the recording level of the recording amplifier to "0" VU at 1,000 Hz.
- Distortion level at 7-1/2 ips should be within 1.7%, and at 3-3/4 ips, within 3%.
- Bias voltage should be within 3 to 6 V.

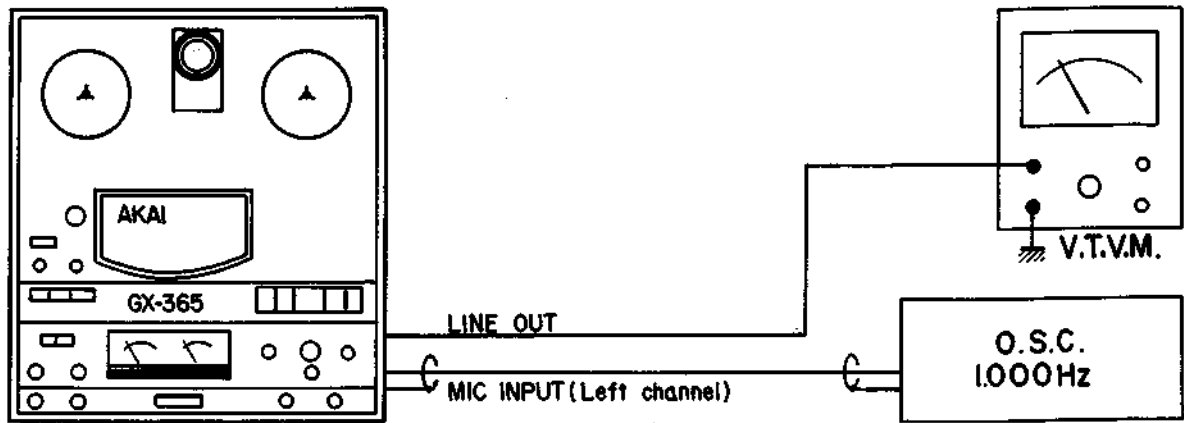

Fig. 4

6. ADJUSTMENT OF COMPUT-O-MATIC RECORDING LEVEL SENSITIVITY

- a) As shown in Fig. 4, connect an audio oscillator to the left Mic Input jack and a V.T.V.M. to the left Line Output of the tape recorder. Supply a 1,000 Hz signal 4 mV to the Mic Input with the Audio Oscillator.
- b) Depress "Source" Button. Set Track Selector to "Stereo".
- c) When the COMPUTE-O-MATIC Button is depressed, the V.T.V.M. meter needle should indicate +4 dB (± 2 dB).
- d) If the V.T.V.M. needle does not show the proper indication as described in item (c) above, adjust semi-fixed resistor VR-201 (100 KB) of COM DECTECTOR CARD (RD-A514) so that the V.T.V.M. meter needle indicates +4 dB (± 2 dB).

VII. MECHANISM ADJUSTMENT

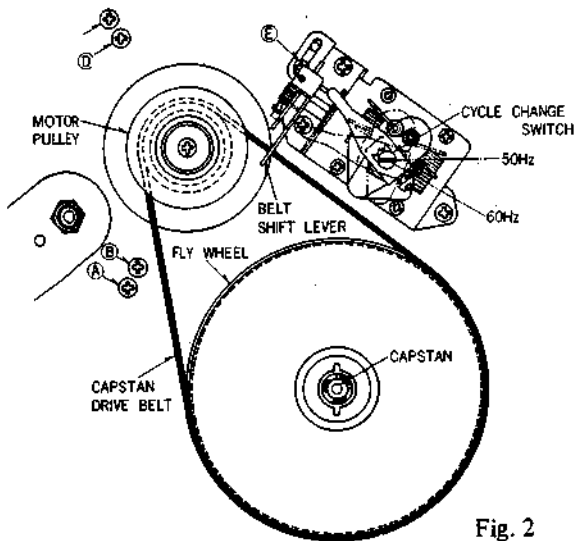

Fig. 2

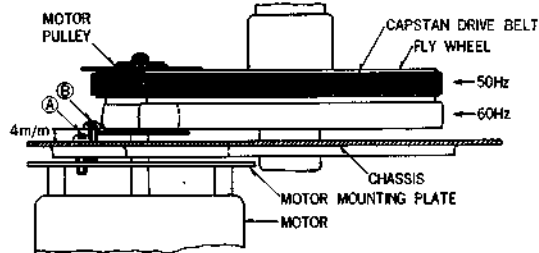

Fig. 1

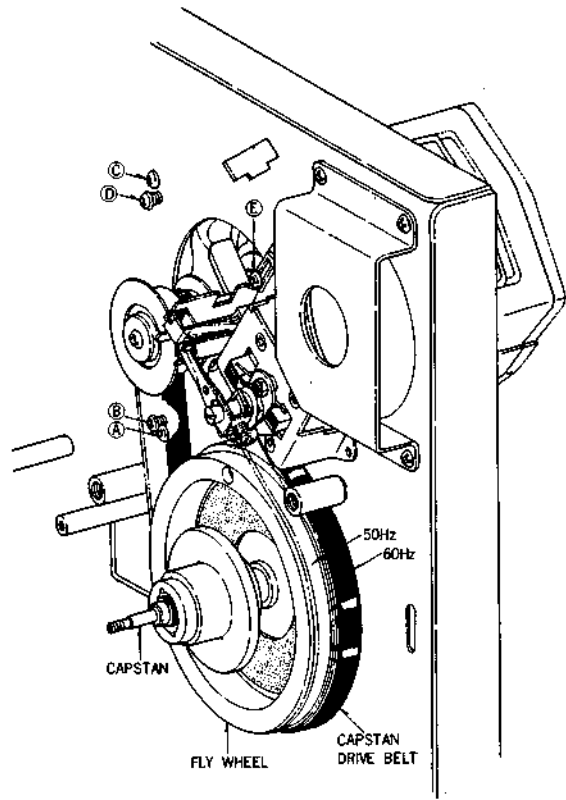

Fig. 1.2

1 Mechanism Adjustment

1.1 Alignment of Capstan Drive Mechanism

The Capstan Drive Belt should run in the center of the Motor Pulley and Flywheel, as shown in Figure 1. To position the Capstan Drive Belt, with proper clearance between the Motor Mounting Plate and the Chassis, use adjusting Screws (C) and (A), shown in Figure 2. After adjustment, tighten Lock Screws (B) and (D).

- 1) With Motor rotating in the Normal direction, loosen Screws (B) and (D) and adjust Belt position by turning Screw (C).
- 2) With Motor rotating in the Reverse direction, adjust Belt position by turning Screw (A). After Drive Belt position has been properly adjusted to run in the center of the Motor Pulley and Flywheel (according to direction of motor rotation), lock by tightening Screws (B) and (D).

- 3) With the Motor rotating and with the recorder switched from 50 to 60 Hz, verify that the Drive Belt does not contact the Belt Shift Lever.
- 4) If the Drive Belt contacts the Belt Shift Lever, loosen Screw (E), and move the Belt Shift Lever Stopper so that the Belt does not contact the Shift Lever.

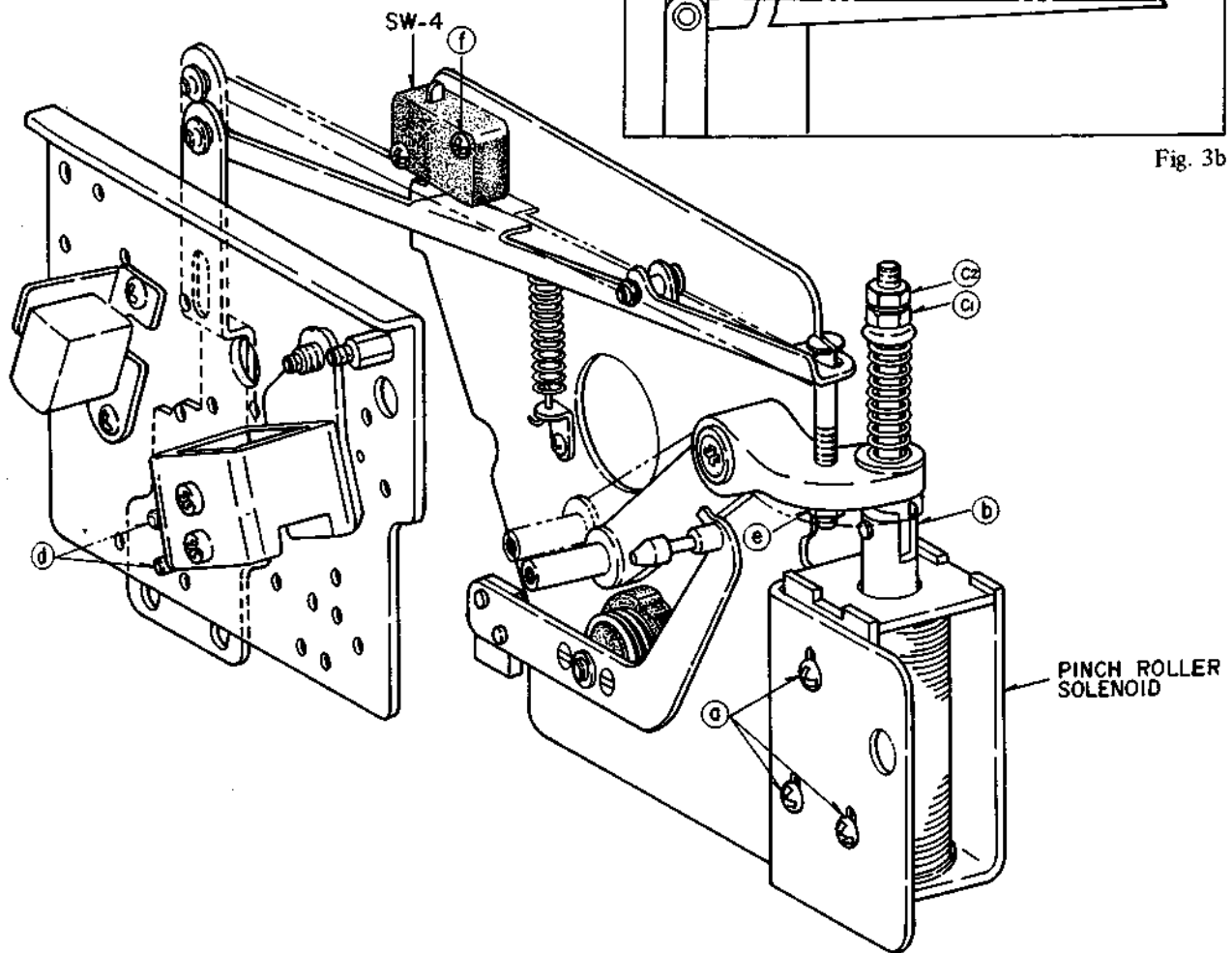

Fig. 3b

Fig. 3a

2. Adjustment of Pinch Roller Mechanism

- 1) Pinch Roller Solenoid Position—Set the Solenoid so that there is approximately 0.3 mm clearance between the end of Plunger (b) and the bottom of the Solenoid when the Pinch Roller Shaft is depressed with your finger, and then tighten Screw (a). (See Figure 3a)
- 2) Pinch Roller Pressure—Apply a Tension Gauge to the Pinch Roller Shaft, and adjust Nut (C1) so that pressure is 1.8 kg/cm when set for Playback. Then tighten Nut (C2) and secure with Nut (C1).
- 3) Adjust Nut (e) so that there is approximately 0.5 mm clearance between Shifter Pin (d) and the upper edge of the hole in the Head Mounting Plate when set for Playback.
- 4) Set to Playback with the Pinch Roller contacting the Capstan and verify that the Tape Shifter Lever depresses Microswitch SW-4 as shown in Figure 3b, and make sure that the switch operates correctly. To adjust position of Microswitch SW-4 loosen Screw (f).

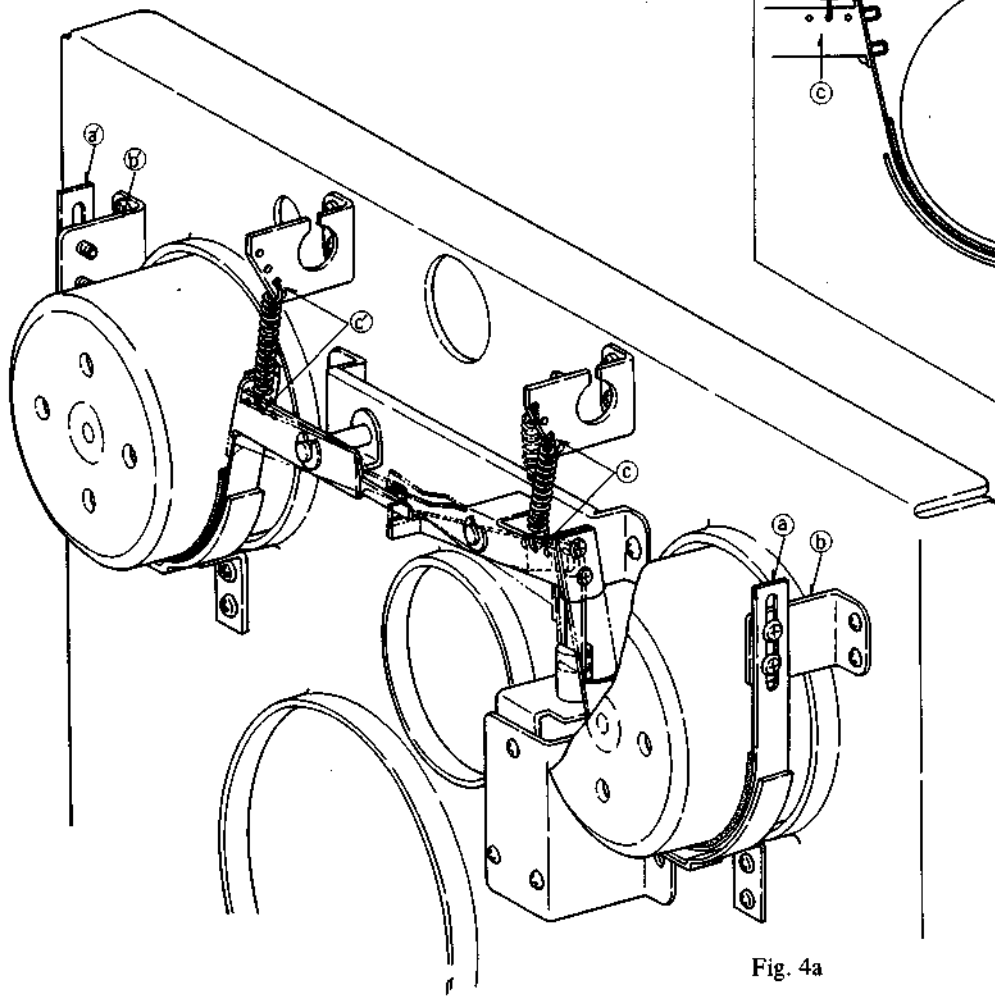

Fig. 4a

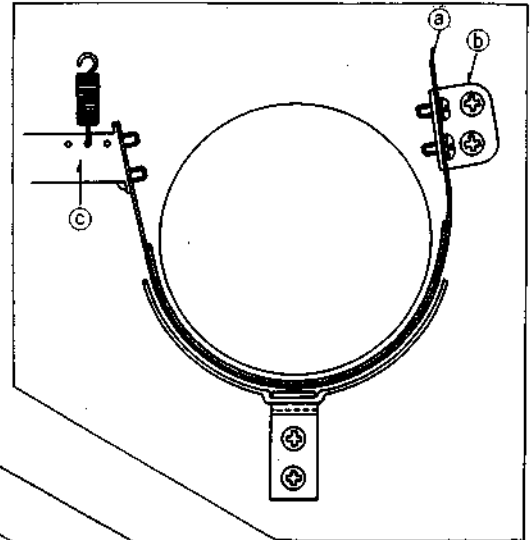

Fig. 4b

3. Adjustment Brake Mechanism

- 1) To adjust Brake Solenoid position, align the Left and Right Brake Levers when the Solenoid Plunger is retracted.
- 2) One end of the Brake Band is centered in the elliptical hole in the Brake Band, as shown by (a) (a') in Figure 4a.
- 3) For metal Brake Band Retainer, adjust Screw (b), so that the clearance between the Brake Band and motor circumference is uniform, as shown in Figure 4B.
- 4) Adjust the set position of the Brake Band Spring so that Brake tension is 150 grams (using 60 mm diameter tape and measuring with a Tension Gauge) (See Figure 4a (c) (c')).

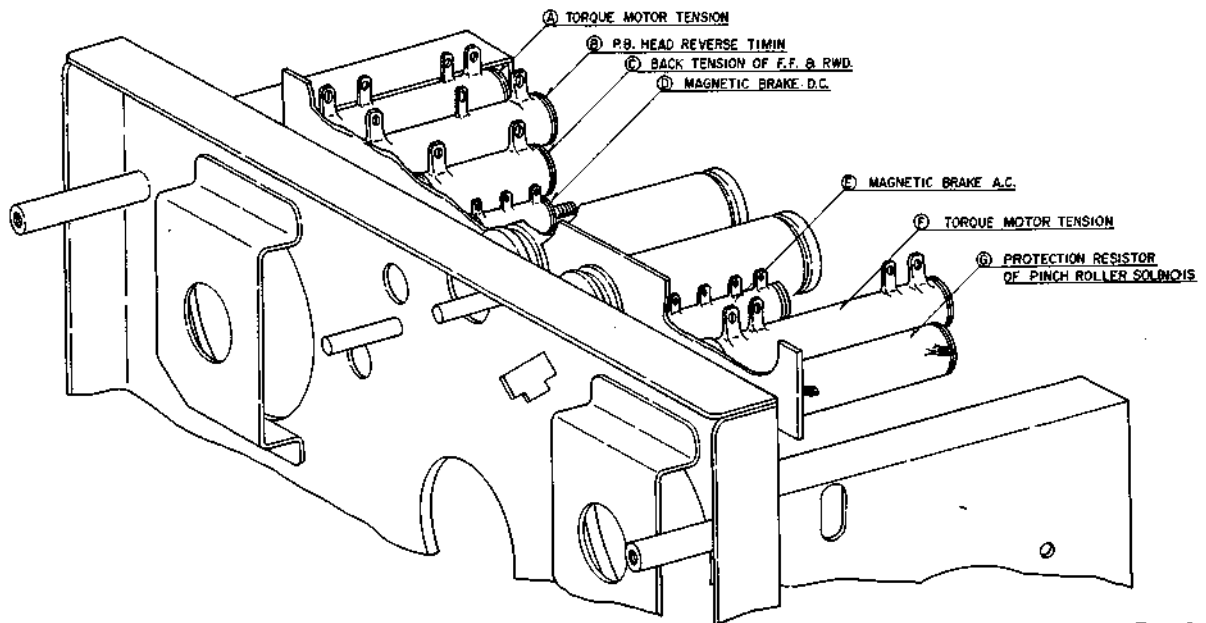
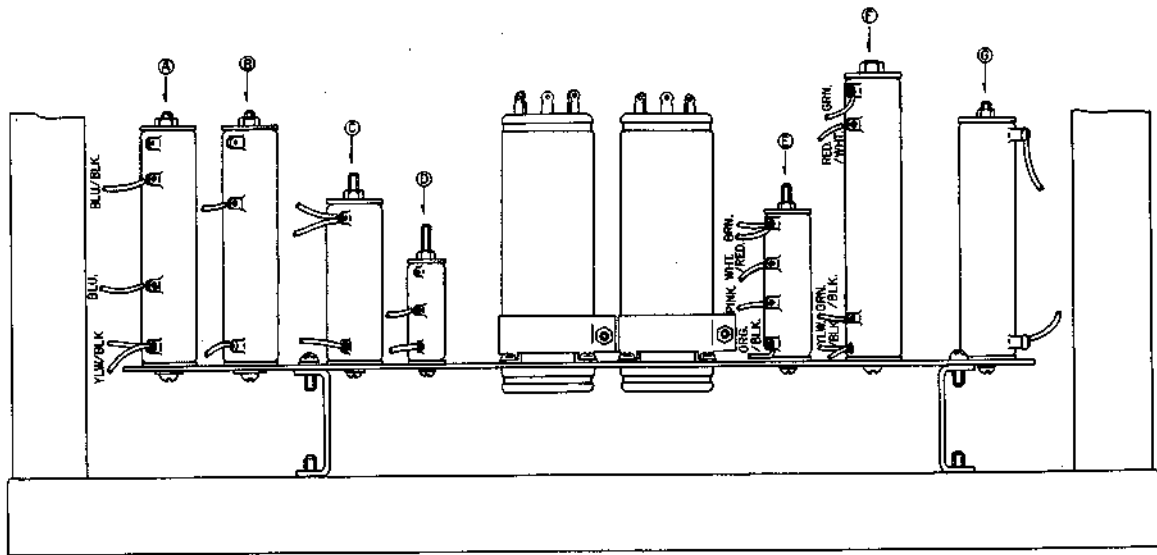

Fig. 5

4. Adjustment of Tape

For all measurements, use 60 mm diameter tape, and measure tape tension with a Tension Gauge. Set the Magnetic Brake Control Switch to 1-1/2 mil (Standard).

- 1) Back tension for "Reverse Play" depends upon the torque of Motor B, as shown in Figure 6. Back tension is about 60 grams. At this tension setting, voltage applied to Motor B is approximately 29 V.
- 2) Take-Up tension for "Normal Play" depends upon the torque of Motor B. Take-up tension is about 100 grams which is applied through the 120 Ω Resistor (A), as shown in Figure 5. At this tension setting, voltage applied to Motor B is approximately 41 V.
- 3) Back tension for "Normal Play" depends upon the torque of Motor A, as shown in Figure 6. Back tension is about 60 grams which is applied through 230 Ω Resistor (F), as shown in figure 5. At this tension, voltage applied to Motor A is approximately 29 V.
- 4) Take-up tension for "Reverse Play" depends upon the torque of Motor A. Adjust Take-up tension to about 220 grams by adjusting the 120 Ω Resistor (A), as shown in Figure 5. At this tension, voltage applied to Motor A is approximately 62 V.

5. Adjustment of Playback Head Reverse Timing

The Playback Head reproduces on Tracks 1-3 for "Normal Play" and on Tracks 2-4 for "Reverse Play" when using Stereo Tape.

The Playback Head lowers to Track 2-4 position, when switched from Normal to Reverse Play. If the Playback Head lowers with the tape contacting the Head, a loud noise will be heard from the speaker. The Tape Shifter releases the tape from contact with the Playback Head before the Head lowers.

In such a case adjust 650 Ω Resistor (B), as shown in Figure 5, so that 38 Volts is applied between the terminals (white and gray wire) (Reverse Head Solenoid Coil).

6. Adjustment of Magnetic Brake

1) Adjust 400 Ω Resistor (E) (in Figure 5) so that the terminals on each end of the Resistor are equidistant.

2) Center the Slider of the 1 K Ω Resistor (D), as shown in Figure 5. (D.C. Brake)

3) Set the Magnetic Brake Control Switch to 1-1/2 mil. Depress the STOP Button near the outer end of a 7" reel of tape at FAST FORWARD to determine whether the tape turns in the rewind direction.

4) If the tape turns in the rewind direction, increase D.C. Brake voltage by adjusting the Slider (1) of the 1 K Ω Resistor (D) to decrease resistance, or adjust slider (1) toward terminal (3) of the 400 Ω Resistor (E), as shown in Figure 5. Also verify that Brake Band tension is accurately adjusted to 150 grams.

5) Set the Magnetic Brake Control Switch to 1 mil or 1/2 mil and check the following: FAST FORWARD \rightarrow STOP, REWIND \rightarrow STOP. If the tape loses its tension and becomes slack at STOP, move the Slider (2) of 400 Ω Resistor (E) toward Slider (1), as shown in Figure 5.

After the foregoing adjustments, verify (with the Magnetic Brake operating) that torque motor tension is as follows:

1-1/2 mil : approx. 300 to 330 grams.

1 mil or 1/2 mil : approx. 250 grams.

7. Adjustment of Back Tension for FAST FORWARD and REWIND:

1) Adjust the slider of the 1.7 K Ω Resistor (C), shown in Figure 5, so that overall resistance is 1.3 K Ω . If Resistor (C) itself is 1.3 K Ω , no adjustment is required.

8. Adjustment of Reel Table Height

To adjust Reel height, loosen the two screws on the bottom of the Reel Table and adjust so that height from the Chassis to the upper edge of the Reel Table is 53.5 mm.

VIII. TRANSPORT MECHANISM

Explanation of Relays and Solenoids included in GX-365

REC 2	:	Recording Relay 2 Actuated by REC Relay 1. Switches Recording Head to ON/OFF.
RT	:	Reverse Timing Relay Charges at 220 μ when changing from Reverse to Normal operation.
REV H	:	Head Reverse Solenoid Depresses Playback Head to Reverse position in the reverse mode.
REV 1	:	Reverse Relay 1 Reverses motor rotation. Locks Reverse circuit. Controls PLY Relay.
REV 2	:	Reverse Relay 2 Switches the Reel Motor Tension during Reverse operation.
REV 3	:	Reverse Relay 3 Switches the Playback Head connection (L.ch. R.ch.) during Reverse operation.
PT	:	Pinch Roller Timing Stops tape in 4 seconds while changing Normal and Reverse.
PLY	:	Play Relay Locks BRK., QT., PR. control & PLY circuit.
PR	:	Pinch Roller Solenoid
REC 1	:	Recording Relay 1 Locks REC Relay 2 control and Record- ing circuit.
BIAS	:	Bias Head Control Solenoid
QT	:	Quick Tension Used under all operations and at starting time, operates to provide high force to Reel Motor.
BRK	:	Brake Solenoid
MAG	:	Magnetic Brake Relay Constantly ON during normal operation. In Off position Magnetic Brake circuit operates.
TIM	:	Time Constant Relay ON during Fast Forward and Rewind operations. Controls Magnetic Brake operation.
RWD	:	Rewind Relay
FF	:	Fast Forward
DS	:	Direction Switch Relay Operates only during Rewind mode. Controls the direction of the Magnetic Brake operation.
SENS	:	Sensing Relay Operated by Sensing Tape or Reverse Dial. Also sets Reverse circuit to ON.

1. Relays & Solenoids Actuated for Each Operation (See System Control Board Block Diagram)

Function	R.T.	REV1	REV2	REV3	P.T.	PLY	REC1	REC2	SENS	Q.T.	MAG.	RWD.	F.F.	DS	TIM.	Solenoid				
																REV.H	PR	BIAS	BRK	
Normal Play						○				○	○							○		○
Reverse Play	○	○	○	○	○	○			○	○	○						○	○		○
Recording						○	○	○		○	○							○	○	○
Fast Forward										○	○		○		○					○
Rewind										○	○	○		○	○					○

○ mark indicates "engaged".

Fig. 1

2. STOP

Load a tape and depress the Power Switch. Current flows as indicated by the red line in Figure 2, driving the Main Motor in the normal direction, and lights the VU Meter Lamp.

3. PLAY

With the Recorder is set to STOP, and the FORWARD Button is depressed, current flows, actuating the PLY, QT, and MAG Relays and the P.R. and BRK Solenoids. Tape is fed in the normal (forward) direction at a constant speed as current is supplied through R2-1 and R3-4, 4-1 to Left and Right Reel Motors. To provide increased starting torque for the Reel Motors, the QT Relay is actuated approximately 0.2 seconds after the FORWARD Button is depressed, partially shorting R2-1 and applying higher voltage to the Take-up Motor. The Block Diagram clearly show the operation of the individual relays.

4. FAST FORWARD

When the FAST FORWARD Button is depressed, current flows, actuating the FF, MAG, QT, and TIM Relays and the BRK Solenoid. 100 V is supplied to the Take-up Motor, and 13 V is fed to the Supply Motor through R203, for back tension application during FAST FORWARD feed.

5. REWIND

When the REWIND Button is depressed, current flows, actuating the RWD, QT, MAG, DS, and TIM Relays and the BRK Solenoid. 100 V is supplied to the Supply Motor and 13 V is fed to the Take-up Motor through R2-3, for back tension application during REWIND.

6. Magnetic Brake

When the STOP Button is depressed during FAST FORWARD or REWIND, the Magnetic Brake smoothly and quickly stops the fast moving tape.

a) When the STOP Button is depressed during REWIND, Condenser C107 (10 μF) is discharged through VR101 (100 KΩ) and R106 (6.8 KΩ), as shown in Figure A.

Discharge Time Constant is 2 seconds with SW15 set to 1-1/2 mil, or 4 seconds when set to 1 or 1/2 mil. During discharge Tr101 (2SC372) and Tr102 (2SC728), as well as TIM and DS Relays remain engaged. 65 V AC is supplied to the Take-up Motor through R3-1, 2 (400 Ω) and DC current is supplied to the Take-up Motor Sub Coil through R2-2 (500 Ω) and Diode (10D4), allowing the Take-up Motor to serve as a Brake.

b) When the STOP Button is depressed during FAST FORWARD, the TIM Relay remains engaged, and supplies both AC and DC to the Supply Motor which serves as a Brake for the fast moving tape. When the Magnetic brake Control Switch SW-15 is set to 1 or 1/2 mil, D113 and R202 are cut out from the circuit and AC only is supplied to the Motor.

Because the Brake Band only assists the Magnetic Brake, Brake Tension (Braking Power) applied by the Brake Band can be of a comparatively smaller value than usual.

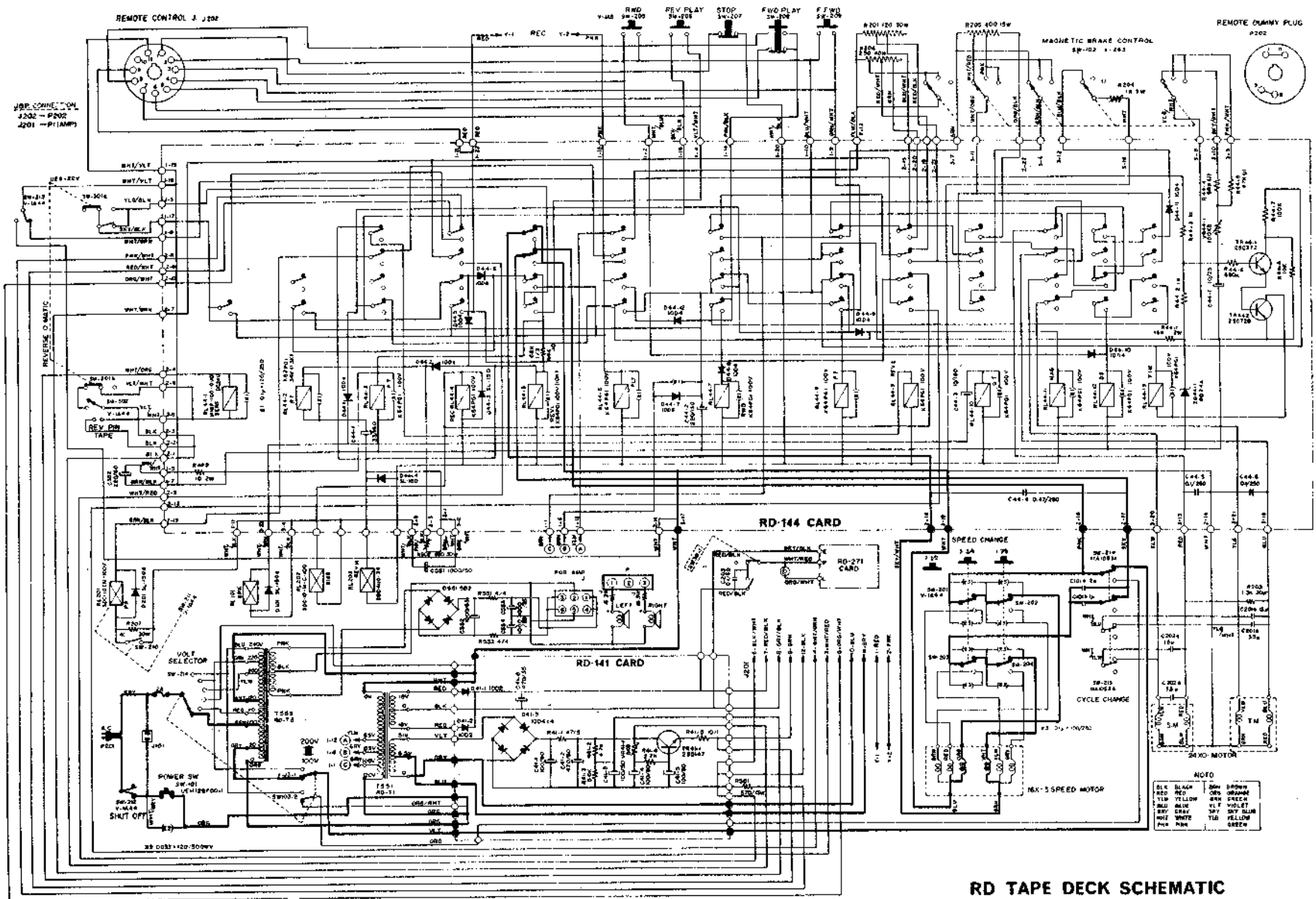

Fig. 2

RD TAPE DECK SCHEMATIC

7. REVERSE PLAY

a) Normal—Reverse

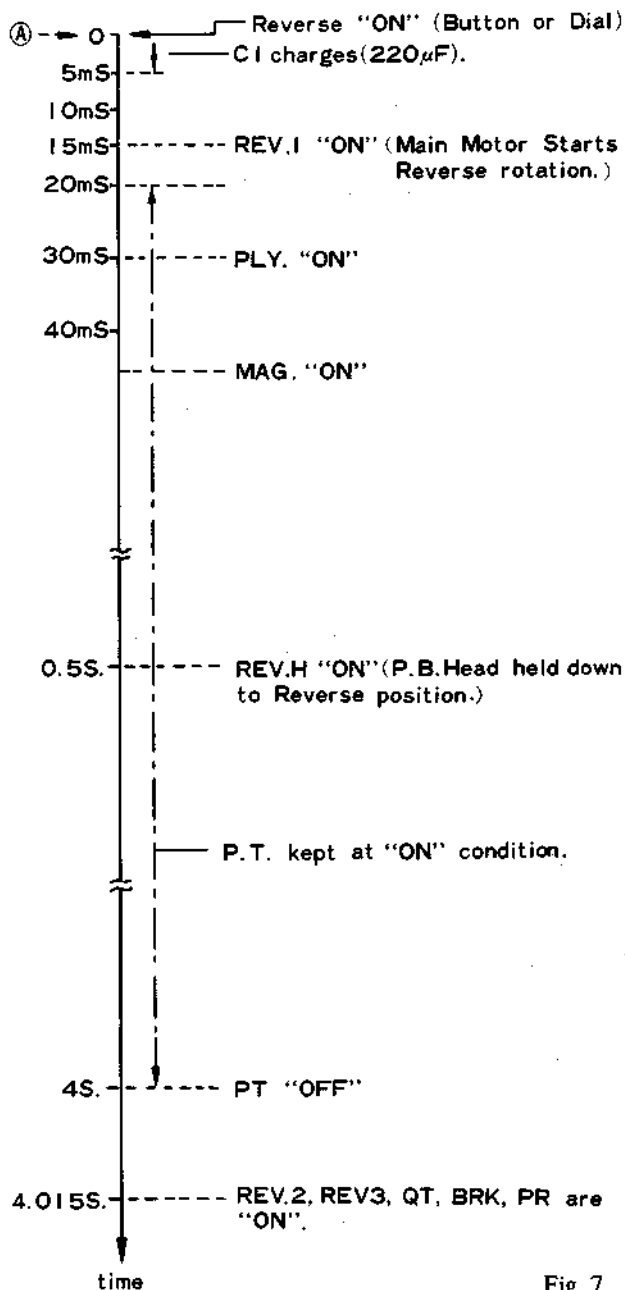
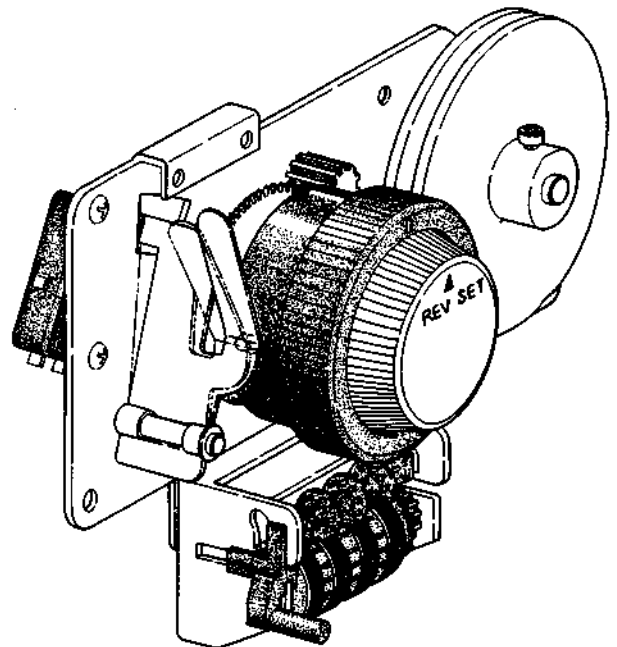

Fig. 7

Sequence of operation when the REVERSE Button is depressed, or when the White Mark on the Tape Count Meter reaches the Black Arrow of the Reverse Set Dial as follows for Automatic Reverse. Assuming this is point (A), Figure 7 shows Relay and Solenoid operating sequence beginning at this point.

Relay operation can be clearly understood by referring to the System Control Board Block Diagram (Figure 8). As soon as REVERSE is actuated ("ON") at point (A), current begins to flow in the Reverse Circuit. Since it takes about 15 milliseconds before the contact is operative, C1 (220 μ F) is charged within approximately 5 milliseconds through REV1-2 (normally closed contact).

15 milliseconds later, REV1 Relay is actuated ("ON") and the normally closed contact of REV1-2, is opened, 220 μ F is discharged through the 10 Ω Resistor and the PT Relay. The PT Relay remains engaged and the pinch roller disengages during the 4-second Discharge Time. The REV1 Relay is actuated ("ON") during this 4 seconds, starting the Main Motor rotating in the reverse direction. PLY and MAG Relays are actuated ("ON"), permitting current to flow to the Left and Right Reel Motors. The REV. H Solenoid is actuated ("ON"), the Playback Head lowers to its REVERSE position. The PT Relay is now cut off, and the pinch roller engages. Approximately 15 milliseconds later the REV2, REV3, and QT Relays and the BRK and PR Solenoids are actuated ("ON"), causing the tape to travel in REVERSE.



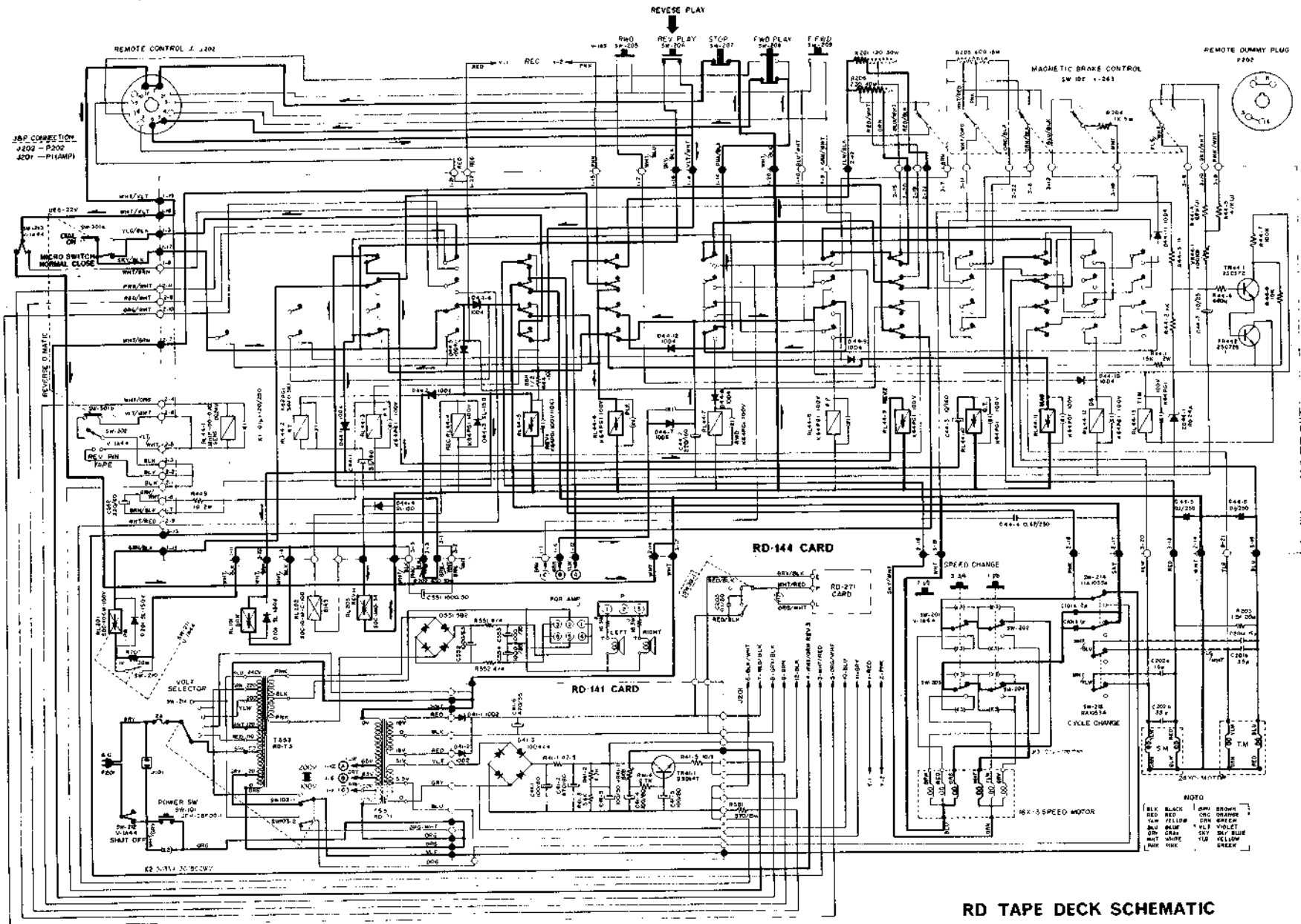

RD TAPE DECK SCHEMATIC

Fig. 8

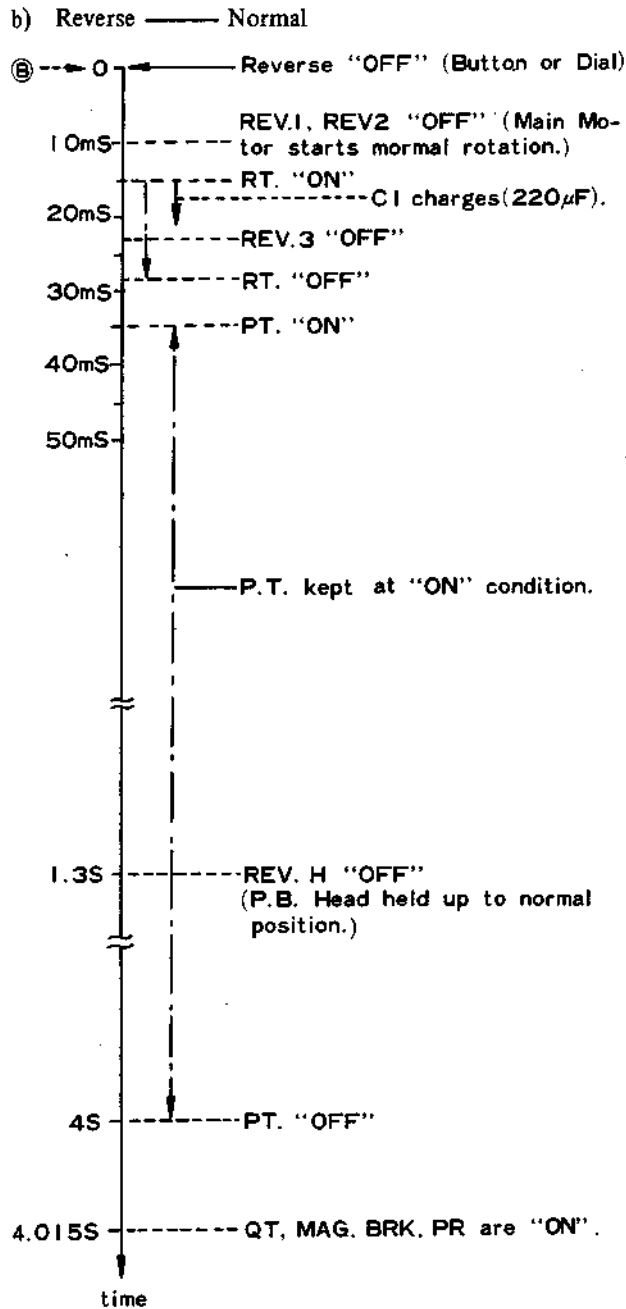

Fig. 9

Sequence of operation when the FORWARD Button is depressed during REVERSE PLAY, or when the White Mark on the Tape Count Meter reaches the "O" Mark on the Tape Count Scale used for Automatic Reverse is as follows, assuming this is point "B".

Reverse Circuit current is cut off at point (B), but REV1 and REV2 remain engaged for approximately 10 milliseconds. As REV1 is disengaged, the Main Motor starts rotating in the Normal direction. When the current in the Reverse Circuit is cut off, the $33\ \mu\text{F}$ Condenser, which in series connects to the RT Relay and charged during Reverse Play, is discharged through the RT Relay Coil and the $650\ \Omega$ Resistor. The Discharge Time is about 28 milliseconds. Thus, the RT Relay remains engaged approximately 13 milliseconds. (See Figure 9) RT1 normally open contact is closed and Condenser C1 ($220\ \mu\text{F}$) is charged in approximately 5 milliseconds.

As RT1 closes, current starts flowing to the PT Relay Coil. As RT1 opens, C1 discharges and the PT Relay is engaged 35 milliseconds later, and continues to be operative for about 4 seconds, after which it is disengaged. C2 ($1000\ \mu\text{F}$) discharges current to the REV. H Solenoid Coil. In approximately 1.3 seconds after point (B), the REV. H is disengaged and the Playback Head raises to its Normal Play position.

As the PT Relay is disengaged, current flows to QT and MAG Relays and to BRK and PR Solenoids through the normally closed contacts. After approximately 15 milliseconds, the QT and MAG Relays and the BRK and PR Solenoids are actuated ("ON"), and tape travel starts in the Normal direction.

IX. MAINTENANCE PROCEDURES

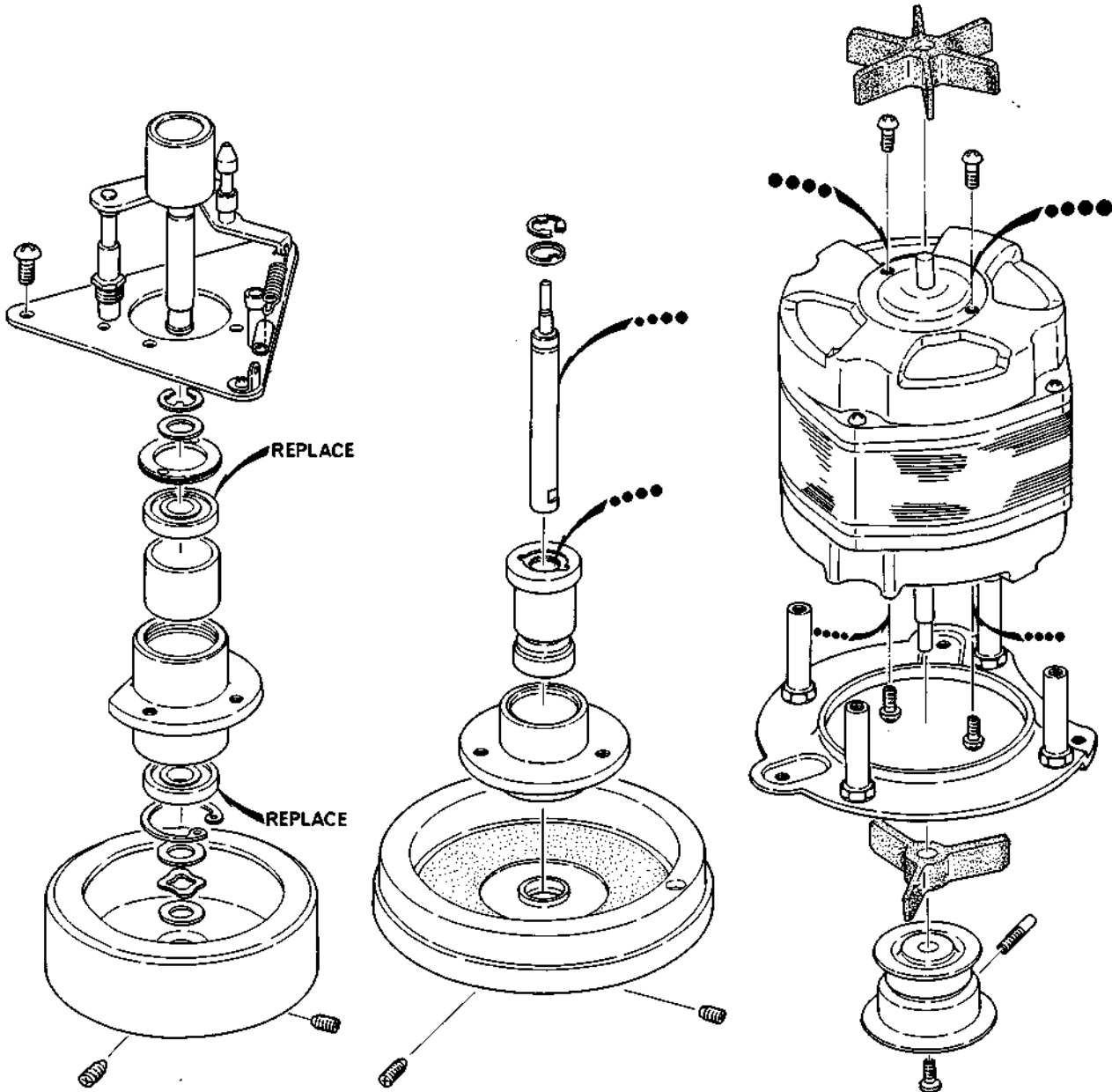

1. LUBRICATION INSTRUCTION

For maximum service life and optimum performance, lubricate the parts identified below after each 1,000 to 1,500 hours of operation. Use only light machine oil of good quality.

- Main Motor
- Capstan Shaft
- Pinch Wheel Shaft
- Tape Counter

Also apply a liberal film of light machine grease to each roller surface of all levers and cams.

CAUTION : DO NOT OVER-LUBRICATE, AND WIPE OFF EXCESS OIL WITH A COTTON SWAB SOAKED IN ALCOHOL. OTHERWISE, EXCESS LUBRICANT MAY BE SCATTERED DURING OPERATION AND THE RUBBER COMPONENT PARTS WILL DETERIORATE.

2. CLEANING TAPE HEADS ETC.

Wipe surface of tape heads, guide roller bearing, capstan bushing and pinch wheel periodically with a soft cloth soaked in alcohol.

X. TROUBLE SHOOTING CHART

SECTION "A" TAPE TRANSPORT MECHANISM TROUBLE

- * If all relays do not operate, first, check the REMOTE DUMMY PLUG (P202).
- * Next, check D10D (D44-7) (Relay, Power Supply) and Condenser 220 μ F or 100 μ F 150V.
- * Check the Relay Print Circuit Board as shown in Fig. First, check each connection point (blank point).
- * When there is no trouble, relays and diodes have normal resistances and distortions.

1. Capstan fails to rotate.

No rotation of capstan motor.	Open field coil	Replace
	Defective starting condenser	Replace
	Defective Relay (REV ₁)	Clean or Replace
Capstan motor rotates normally	Drive belt not properly positioned.	Reposition belt.
	Slipping Motor-Pulley	Tighten set-screw
	Oil on motor-pulley or flywheel	Remove oil.

2. No tape movement at "Play" mode.

Pinch Roller inoperative.	Defective Pinch Wheel solenoid.	Replace.
	Defective Relay (PLY or PT).	Clean or Replace.
No rotation of Torque motor	Defective motor	Replace.
	Defective Relay (PLY.MAG.TIM.REV ₂).	Clean or Replace.
	Defective R2-1 (10 Ω 30W), R3-4 (230 Ω 40W)	Replace.
Brake fails to release.	Brake solenoid does not operate satisfactorily.	Adjust.
	Defective Brake solenoid.	Replace.
	Brake bands, not positioned properly.	Adjust.
	Defective Relay (PLY.PT)	Clean or Replace.

3. Does not "Reverse Play"

Plays only when "AUTO" dial used.	AUTO dial contacts out of adjustment.	Adjust.
Plays only when sensing tape used.	Defective Relay (SENSE).	Clean or Replace.
Plays when REVERSE button is depressed.	Defective Relay (REV ₁ REV ₂)	Clean or Replace.

4. Improper Reverse Operation

Pinch wheel fails to release	Defective Relay (REV ₁ PT. RT & C1)	Clean or Replace.
Tape slow at beginning of REVERSE mode.	C1 not large enough	Add 100 μ F
	Capstan motor does not operate properly.	Check Relay REV ₁
		Replace motor.
		Check AC voltage.

5. Does not rewind.

Rewind motor inoperative.	Defective Motor.	Replace.
	Defective Relay (RWD. MAG)	Clean or Replace.
Rewind motor operates.	Brake fails to release.	Adjust Brake system.

6. Does not "Fast FWD"

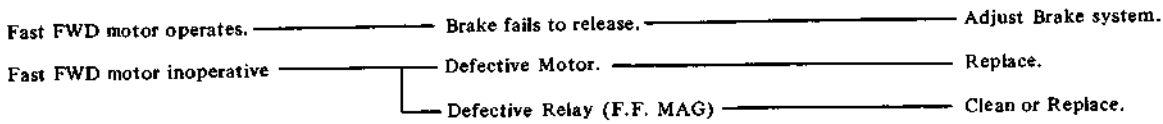

7. Improper Brake operation.

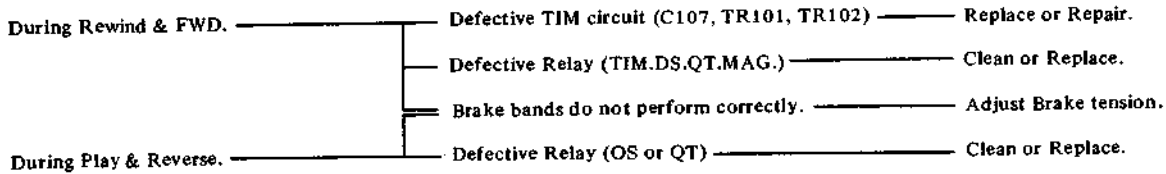

8. Wow, Flutter excessive.

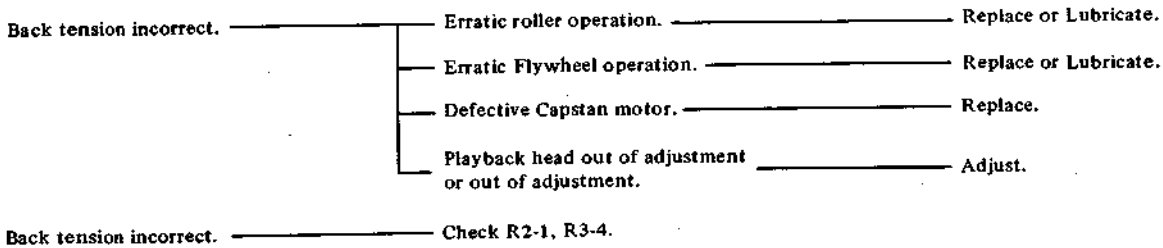

9. Tape speed too slow.

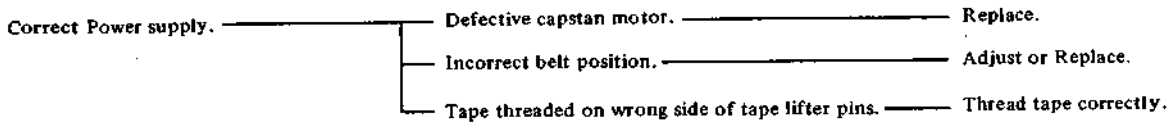

SECTION "B" TROUBLE WITH AMPLIFIER

A. Playback system trouble.

1. No sound from loud speaker.

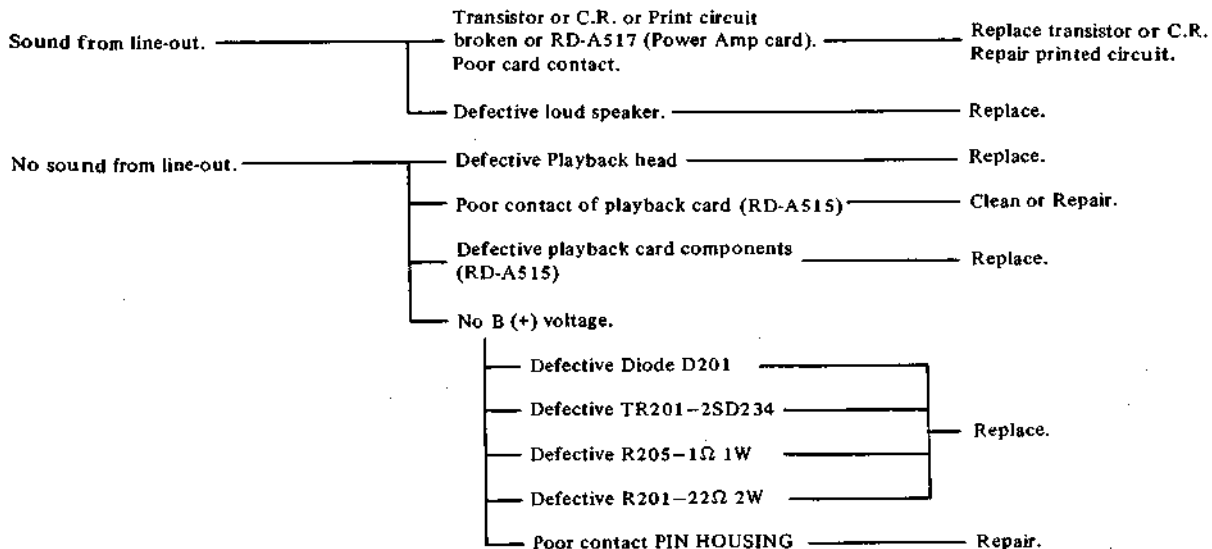

3. Distorted sound.

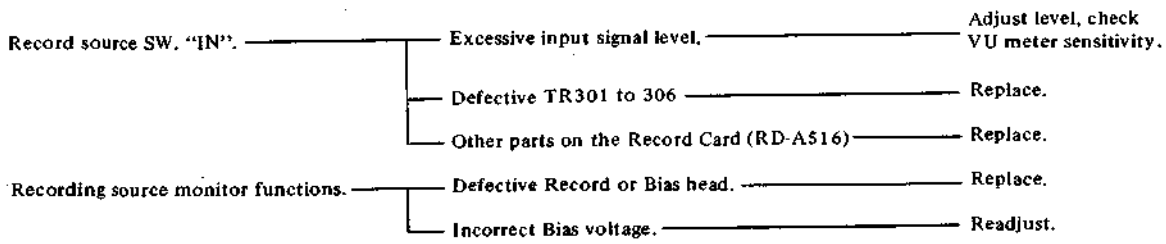

4. Faulty Erasing

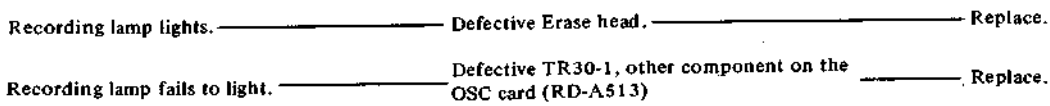

5. Inproper function of Auto VR

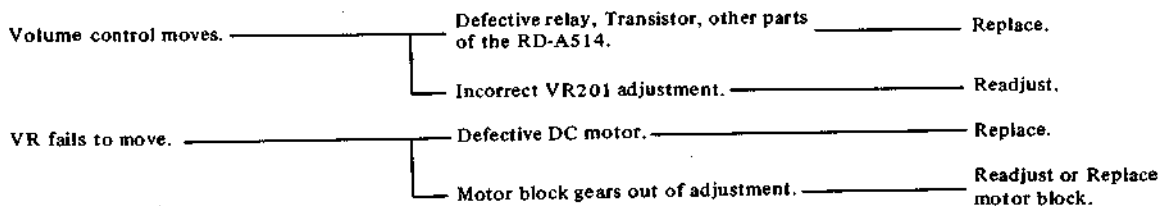

XI. COMPOSITE VIEWS OF COMPONENTS

	Page
POWER SOURCE P.C. BOARD (RD-A209)	31
SYSTEM CONTROL P.C. BOARD (RD-A211)	32
HEAD AMP. P.C. BOARD (RD-A9)	33
SPARK QUENCHER P.C. BOARD (RD-150B)	33
SPEED SELECTOR SWITCH P.C. BOARD (RD-A212)	34
MONITOR SWITCH P.C. BOARD (RD-A506)	34
TRACK SELECTOR P.C. BOARD (RD-A508)	35
COM. MECHANISM P.C. BOARD (RD-A512)	35
OSC. P.C. BOARD (RD-A513)	36
COM. P.C. BOARD (RD-A514)	36
PLAYBACK P.C. BOARD (RD-A515)	37
RECORDING P.C. BOARD (RD-A516)	37
MAIN AMP. P.C. BOARD (RD-A517)	38
TONE CONTROL P.C. BOARD (RD-A518)	38
HEADPHONE P.C. BOARD (RD-524)	39
COM. SET SWITCH P.C. BOARD (RD-525)	39
CHASSIS P.C. BOARD (RD-526)	40

POWER SOURCE P.C. BOARD (RD-A209)

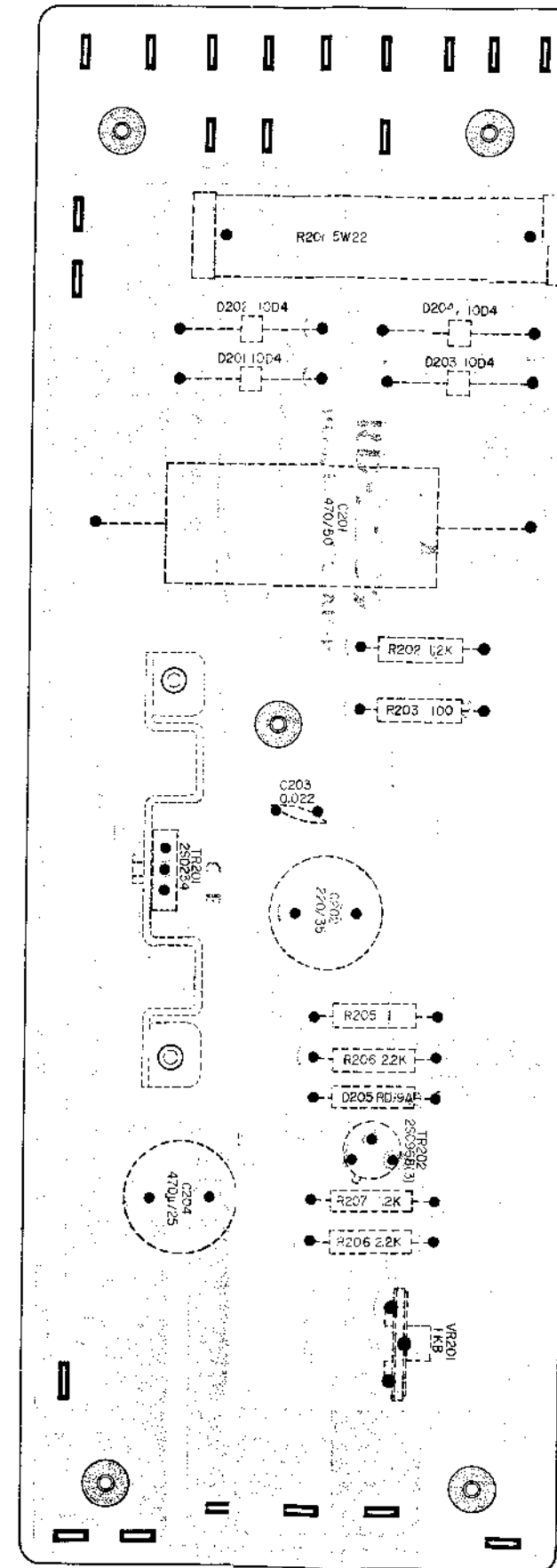

SYSTEM CONTROL P.C. BOARD (RD-A211)

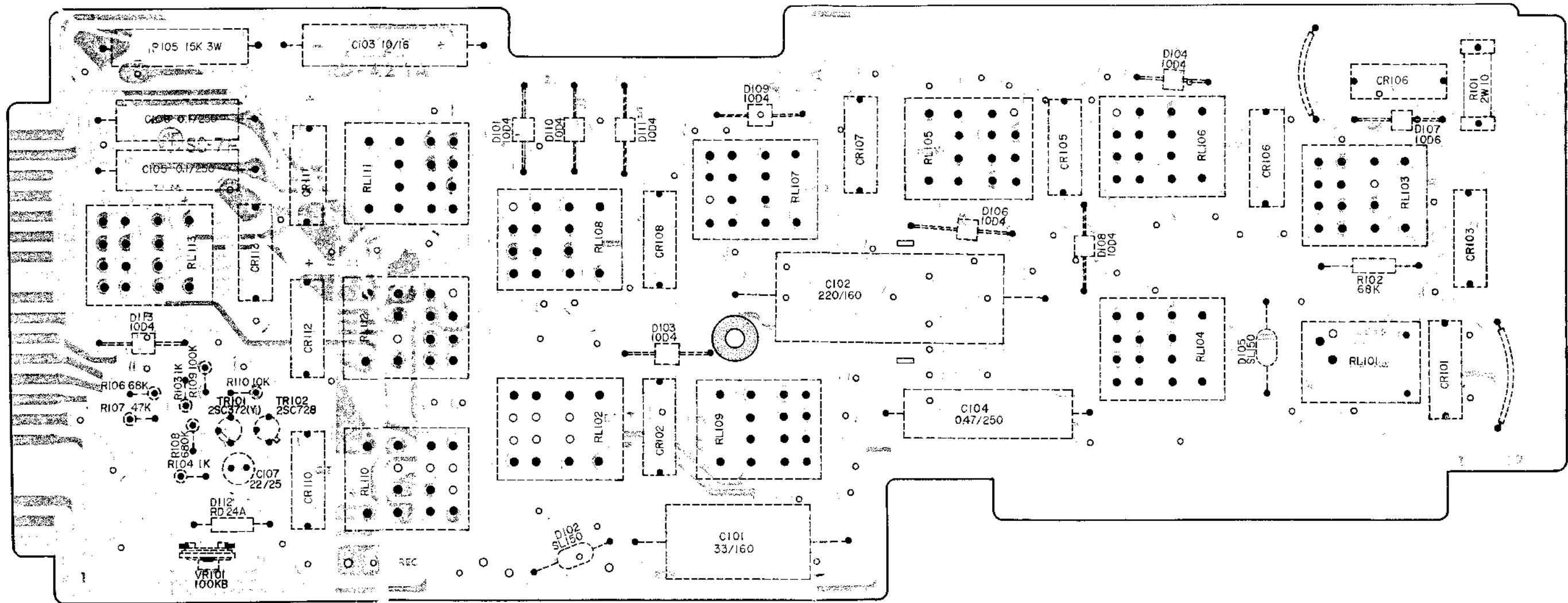

HEAD AMP. P.C. BOARD (RD-A9)

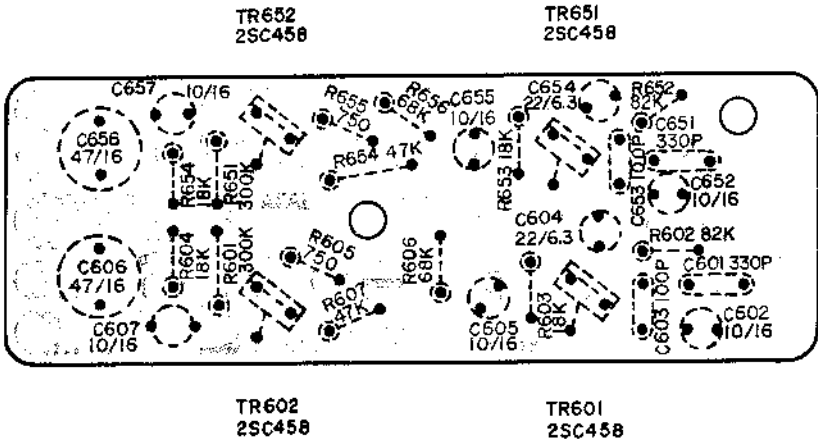

SPARK QUENCHER P.C. BOARD (RD-150B)

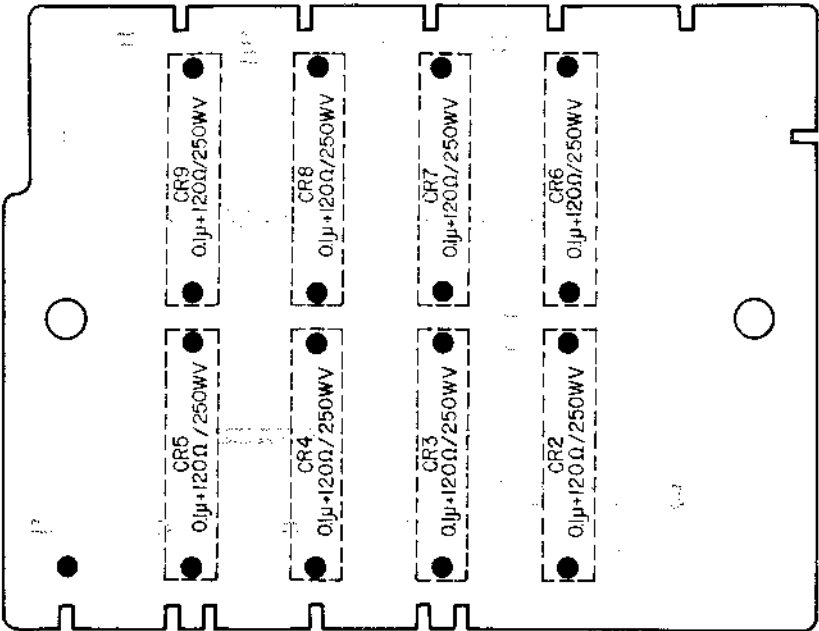

SPEED SELECTOR SWITCH P.C. BOARD (RD-A212)

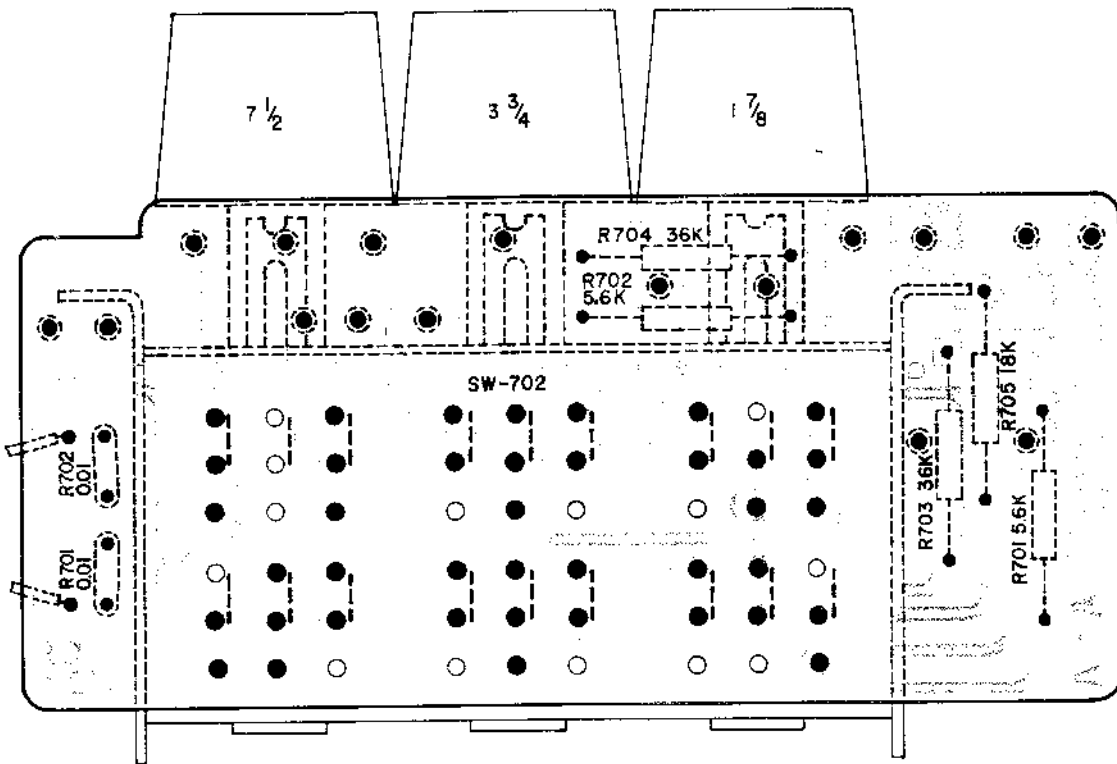

MONITOR SWITCH P.C. BOARD (RD-A506)

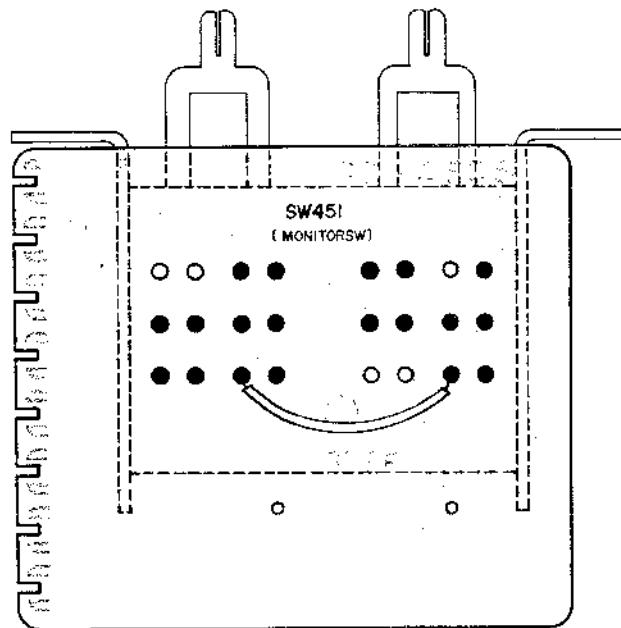

TRACK SELECTOR P.C. BOARD (RD-A508)

COM. MECHANIC P.C. BOARD (RD-A512)

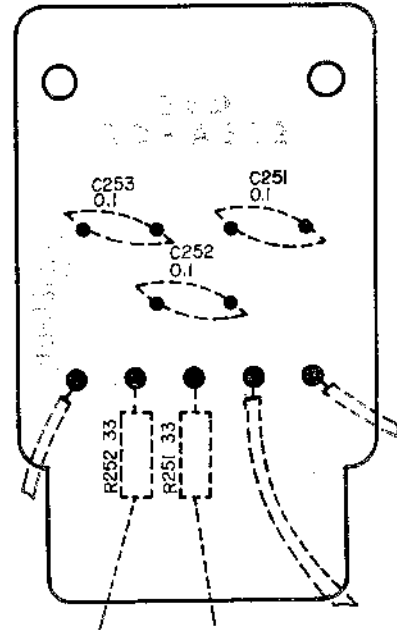
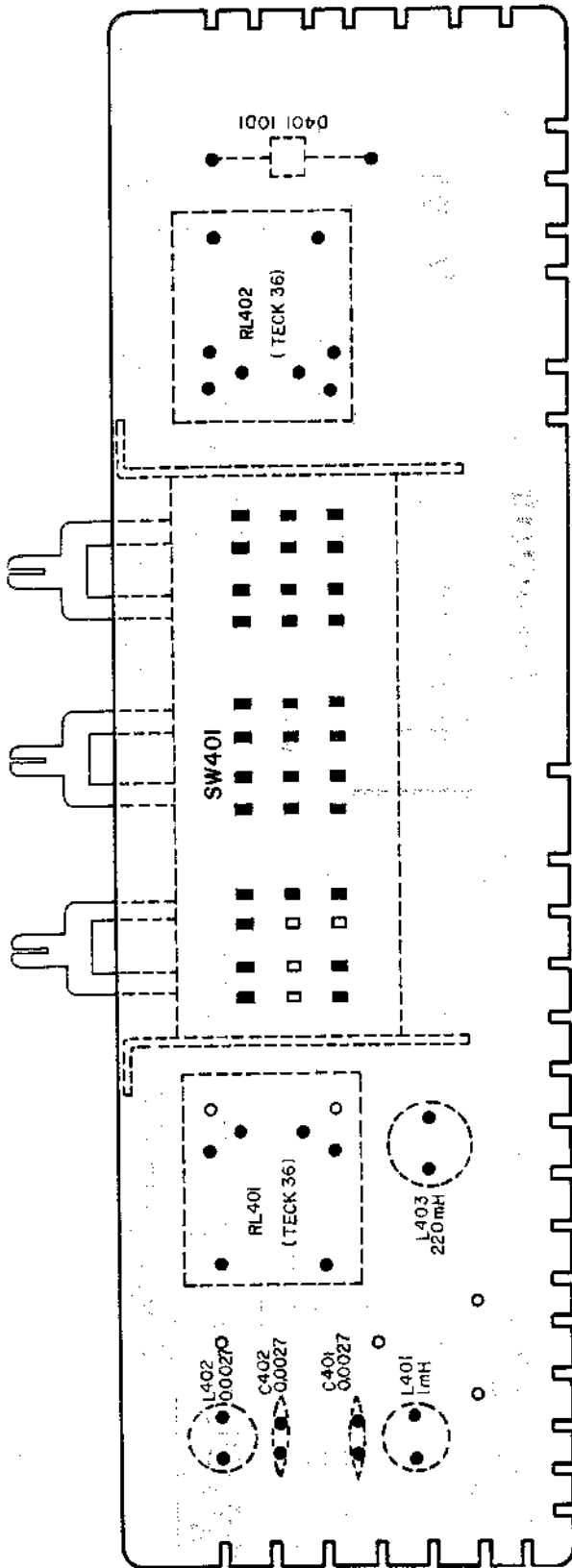

OSC. P.C. BOARD (RD-A513)

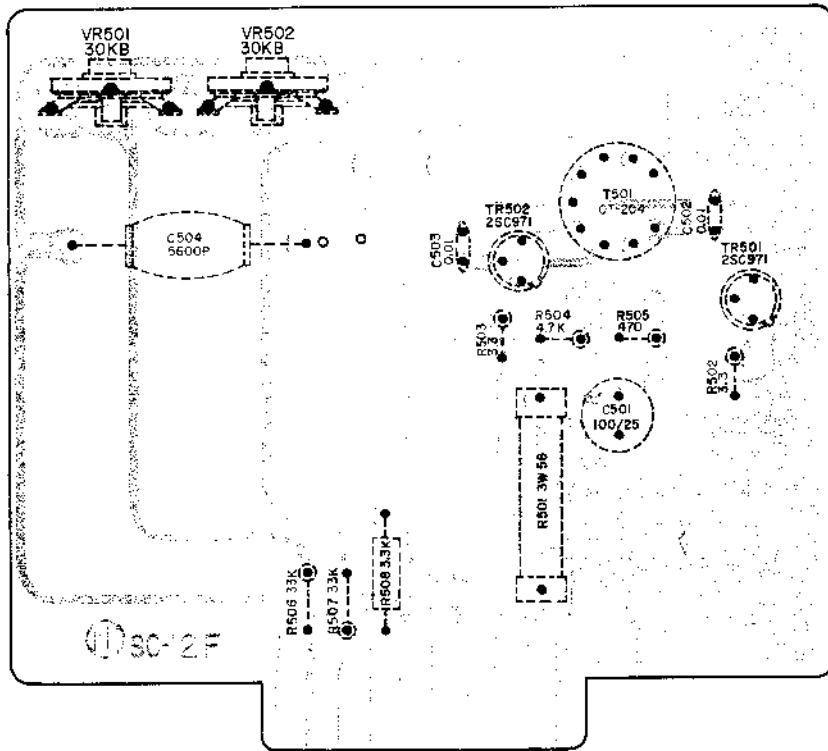

COM. P.C. BOARD (RD-A514)

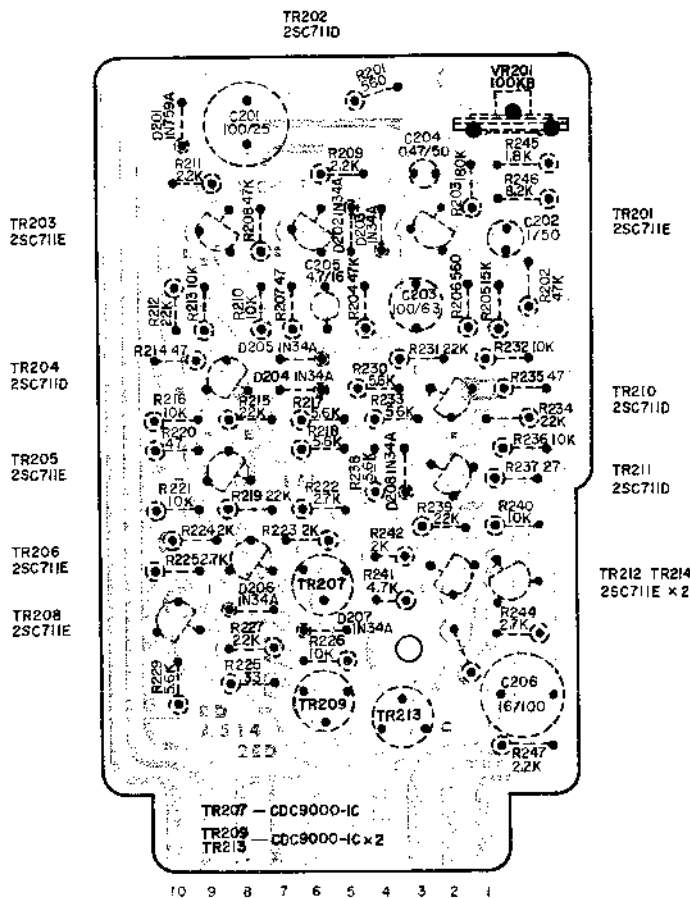

MAIN AMP. P.C. BOARD (RD-A517)

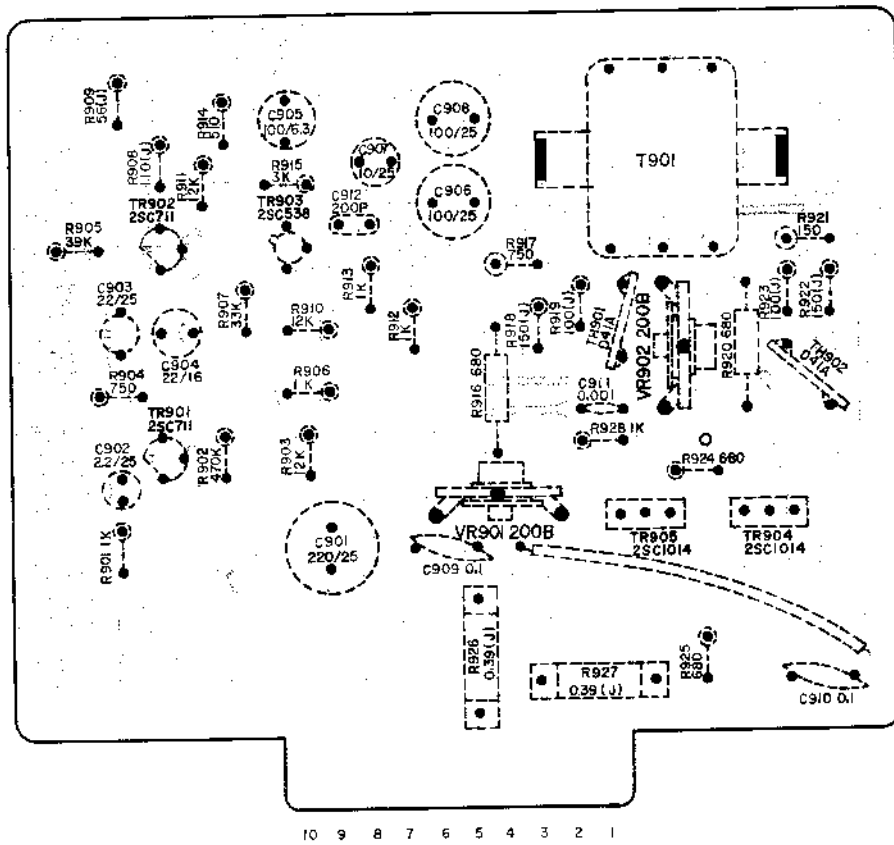

TONE CONTROL P.C. BOARD (RD-A518)

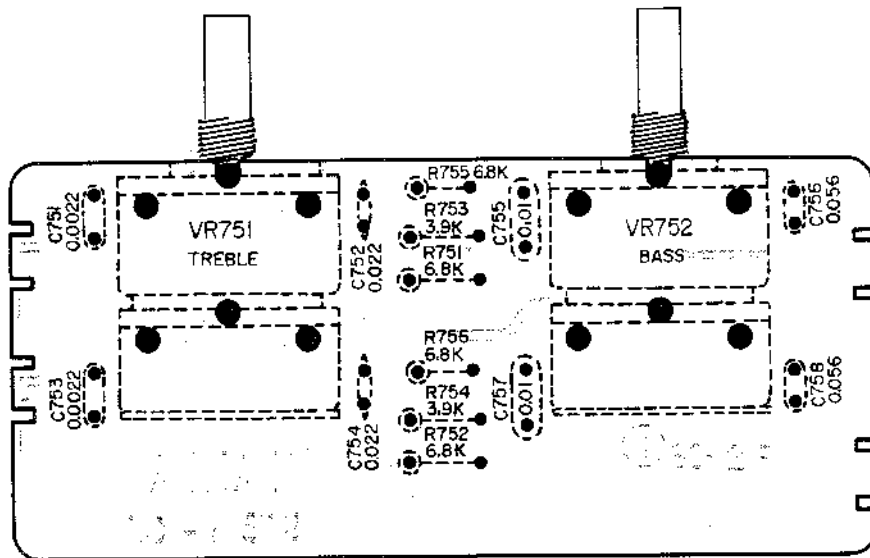

HEADPHONE P.C. BOARD (RD-524)

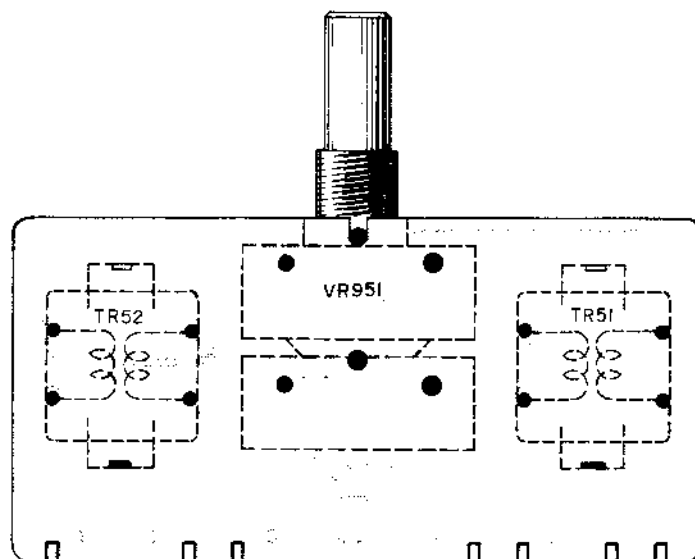

COM. SET SWITCH P.C. BOARD (RD-525)

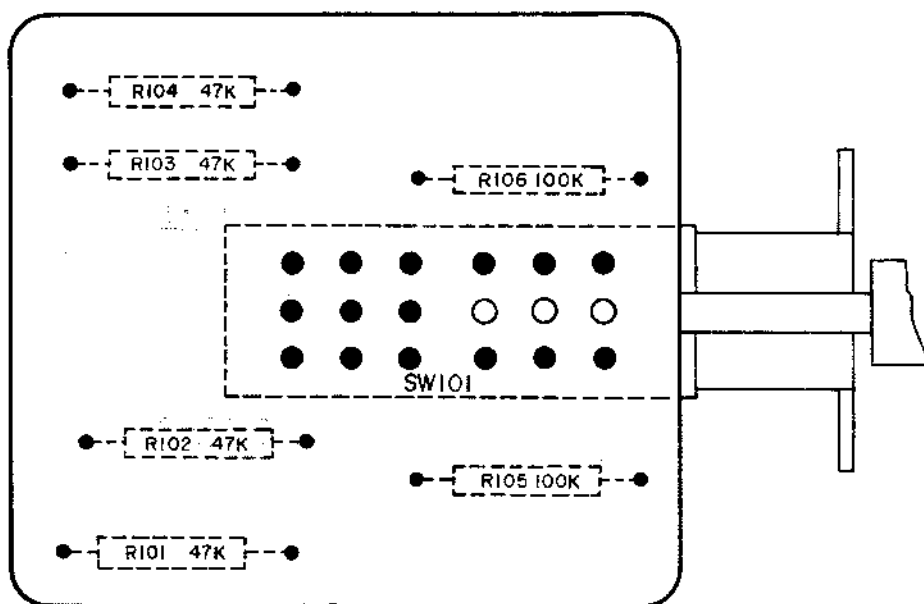

CHASSIS P.C. BOARD (RD-526)

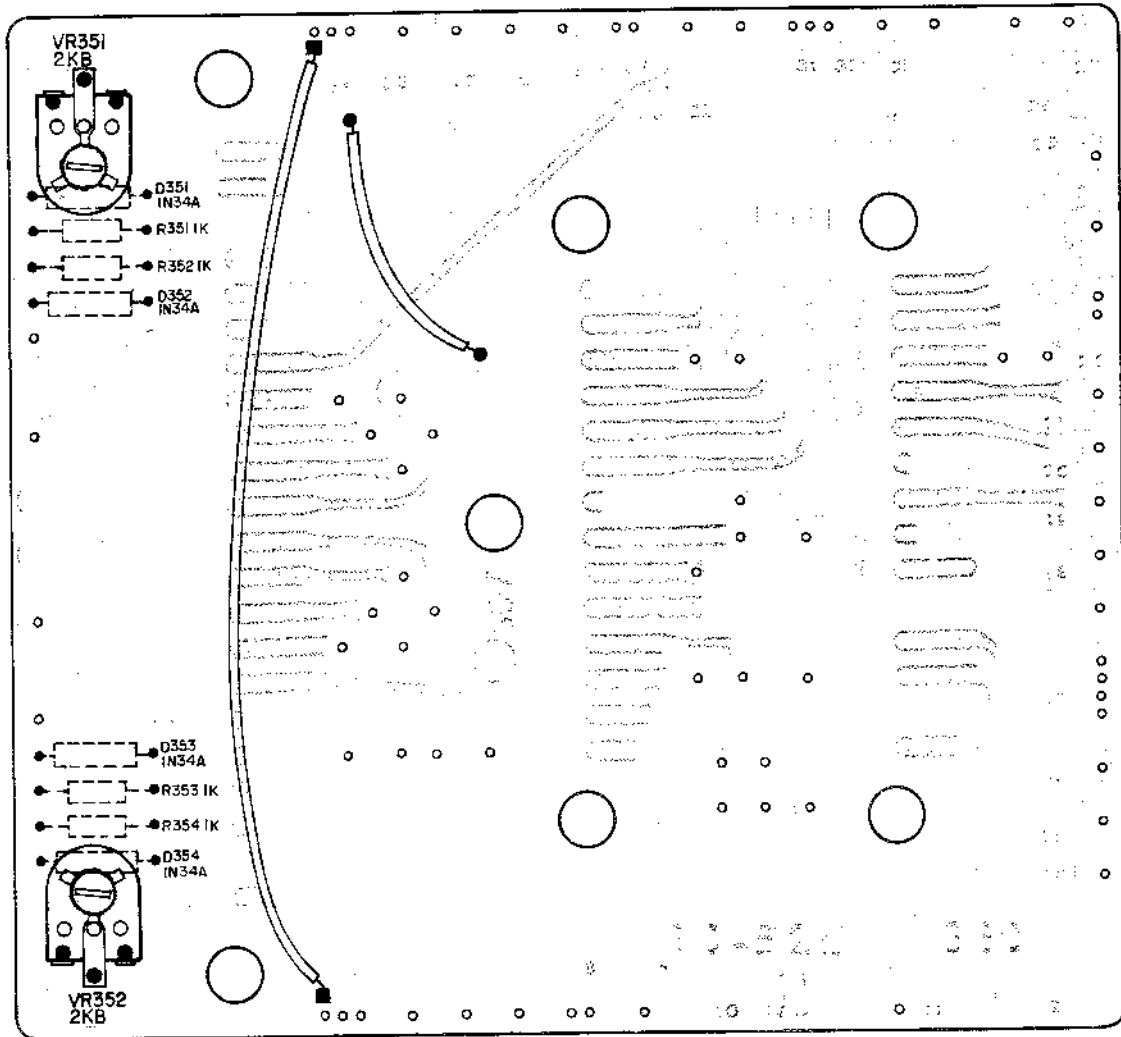

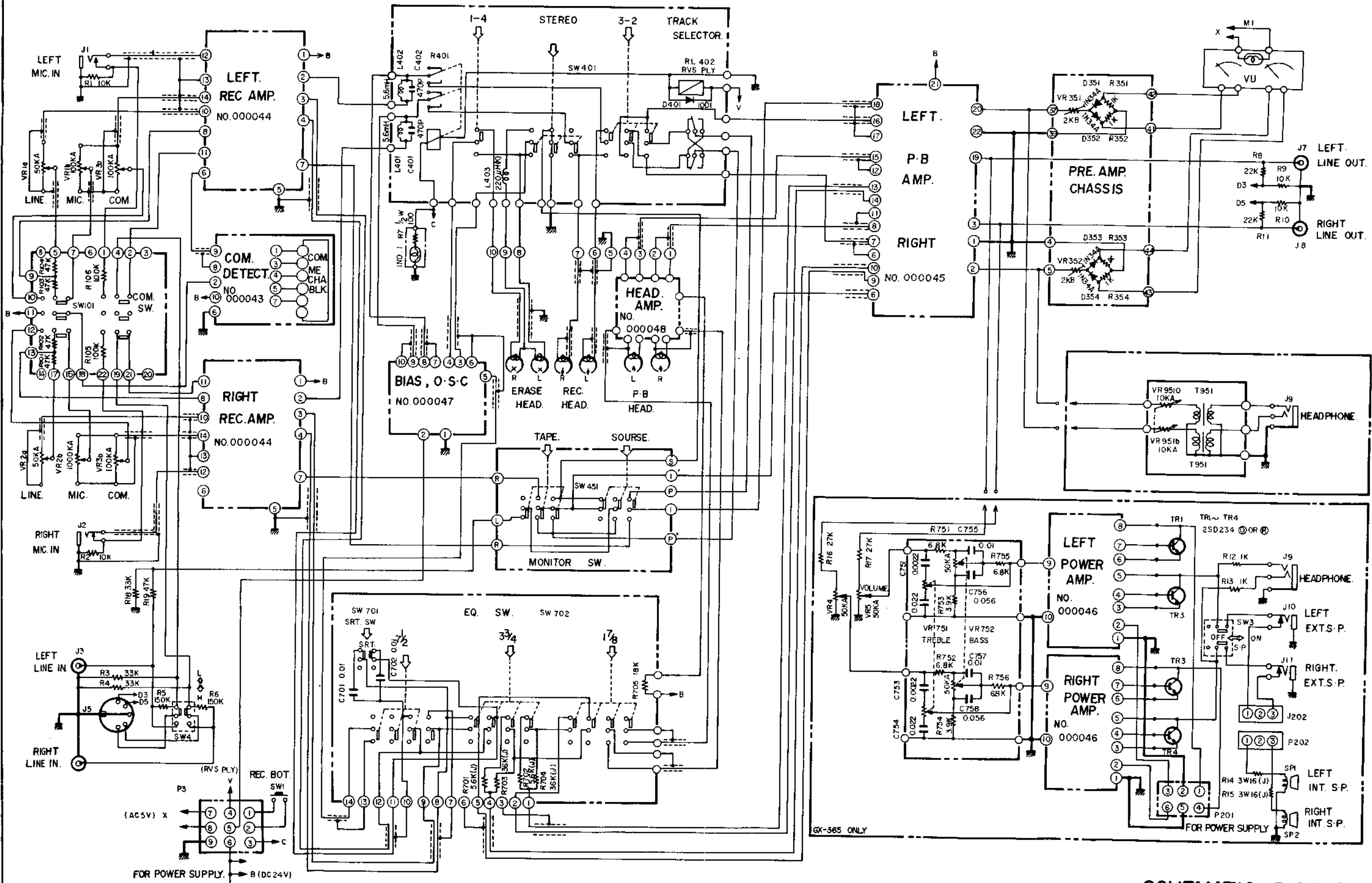

SCHEMATIC DIAGRAM.
GX-365(D) No. 2-1 14016020

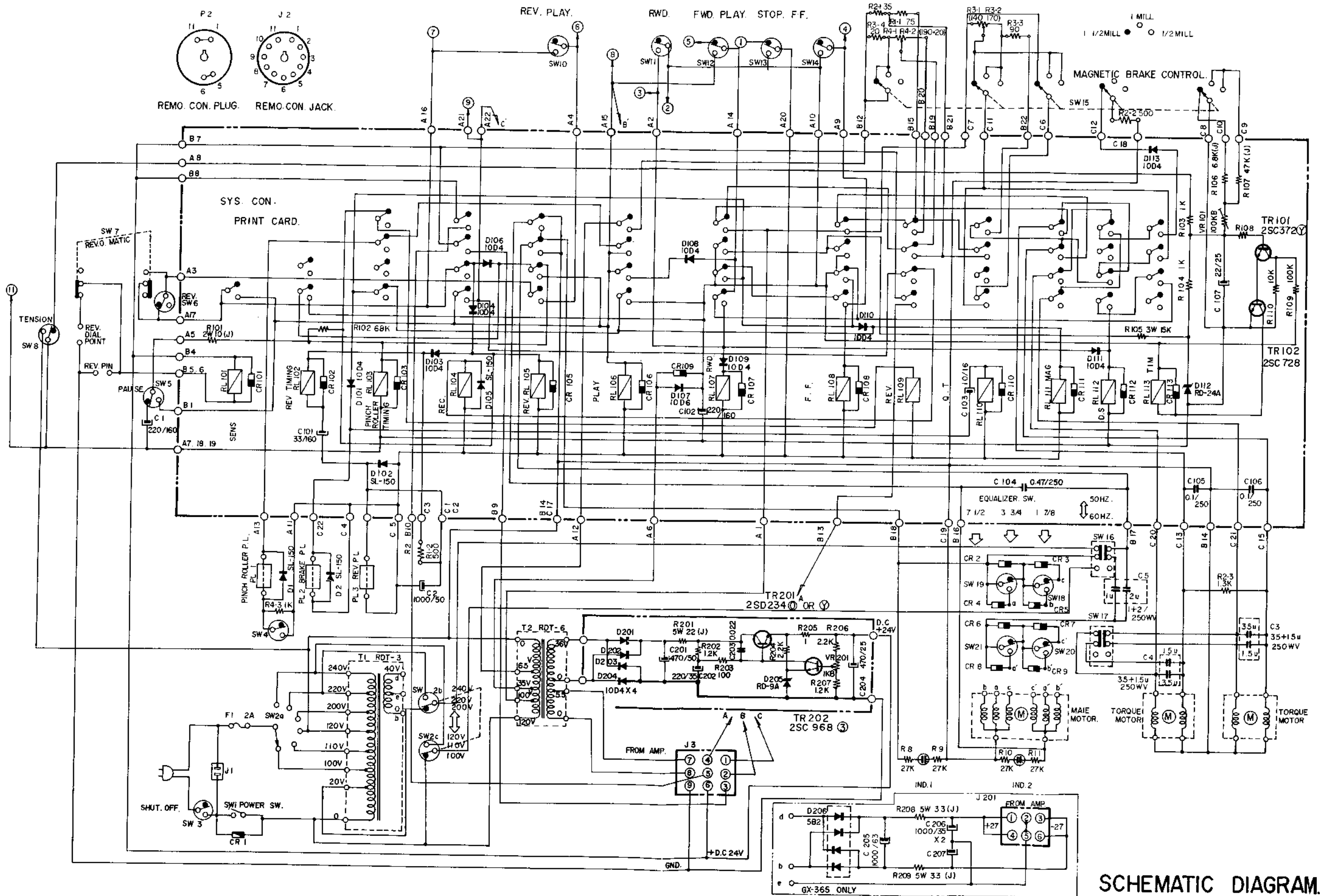

SCHEMATIC DIAGRAM.
 GX-365(D) No.2-2 14016040

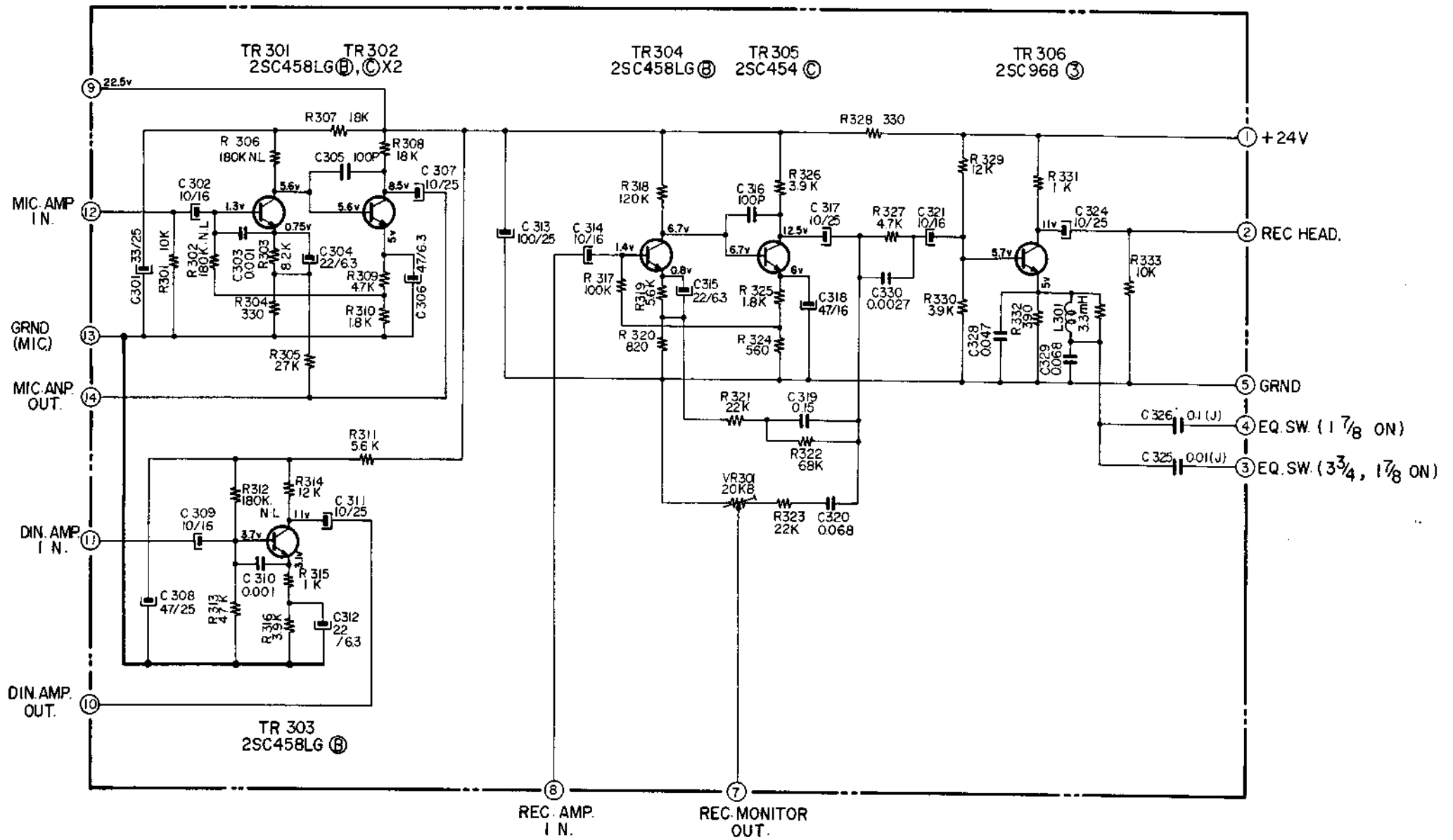

GX-365(D) (REC AMP.) SCHEMATIC DIAGRAM. No.6-2

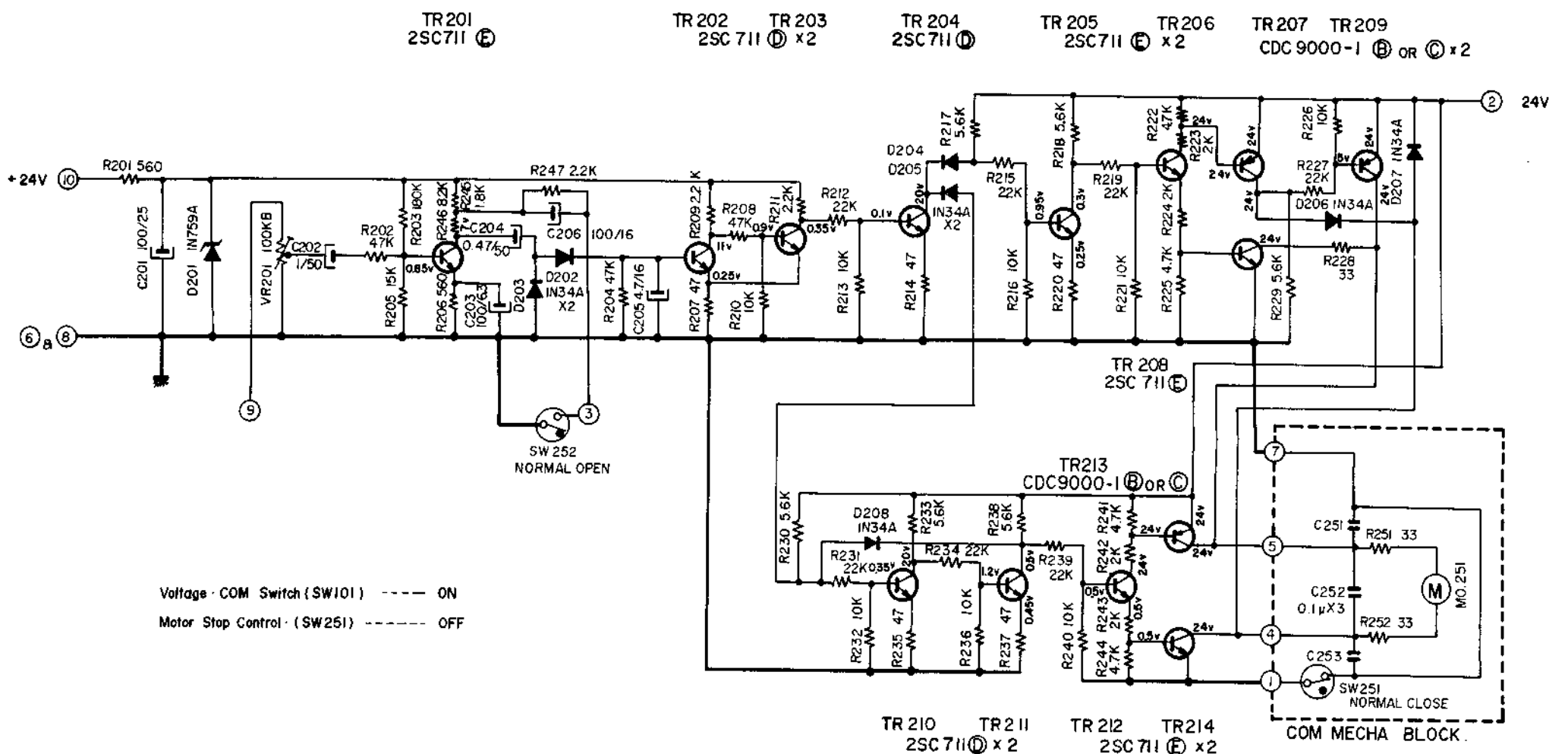

GX-365(D) (COM DETECTOR, COM MECHA BLOCK.) SCHEMATIC DIAGRAM. No.6-1

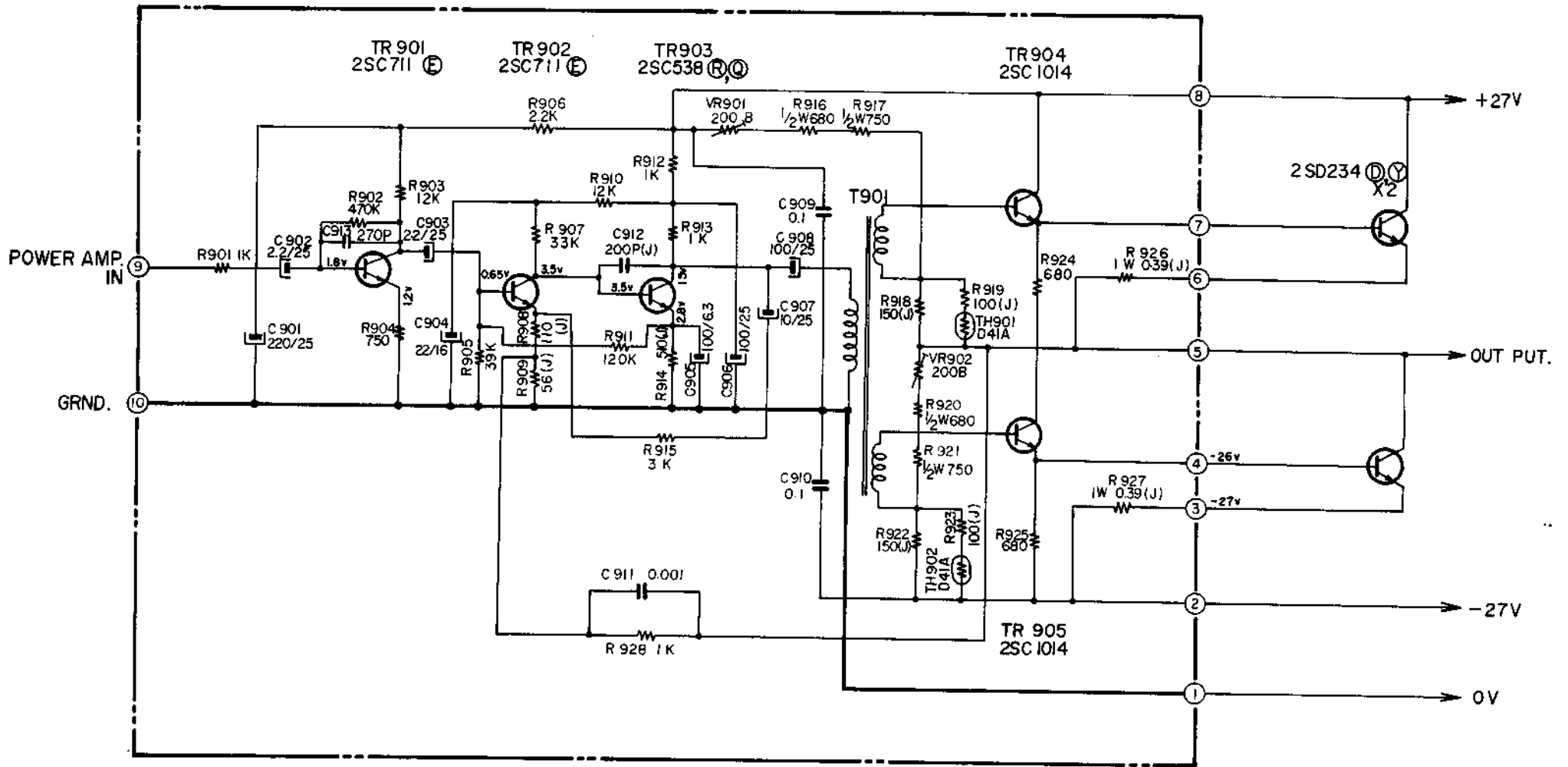

GX-365 (POWER AMP.) SCHEMATIC DIAGRAM. No.6-4

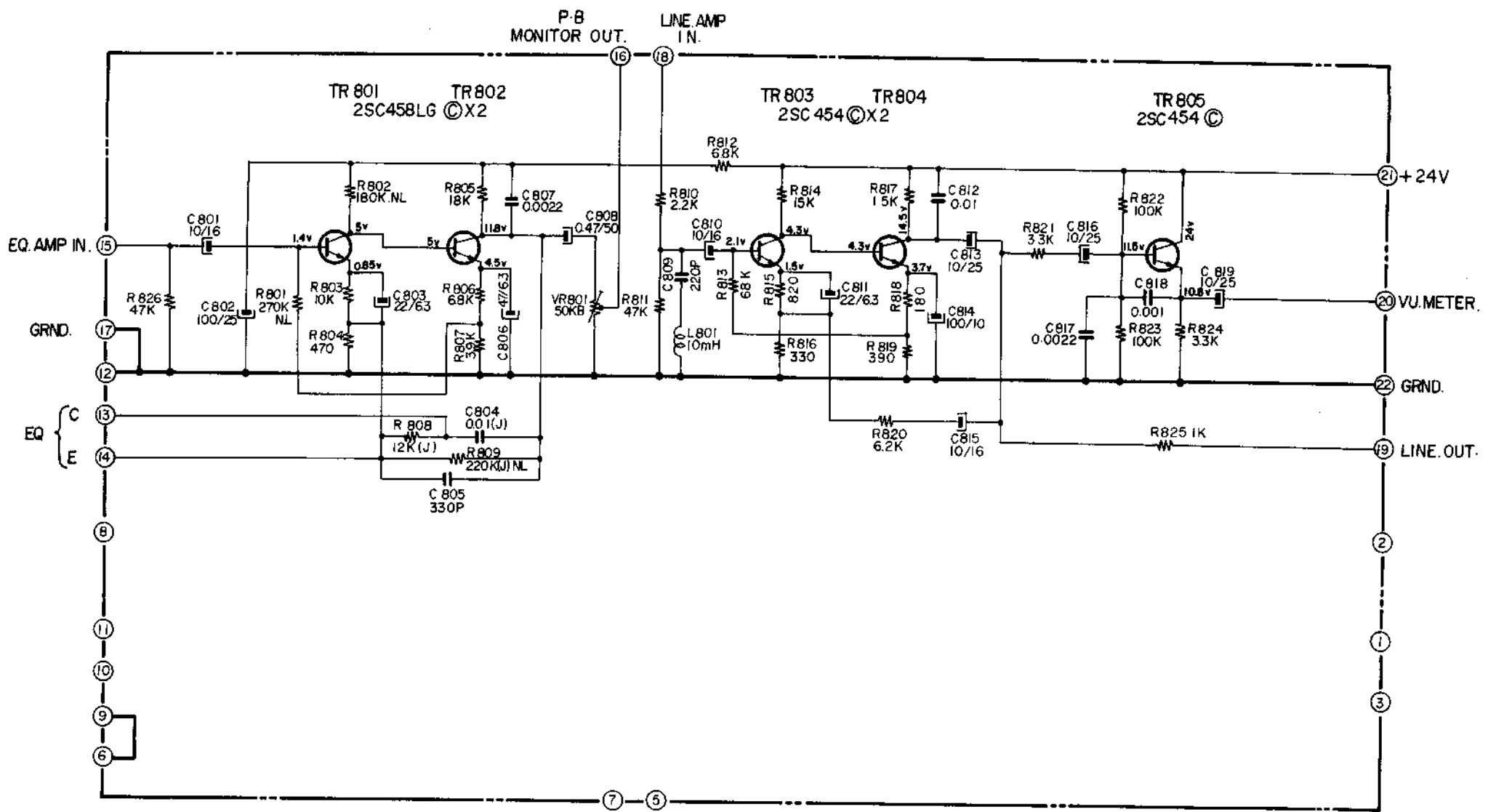

GX-365(D) (P.B. AMP.) SCHEMATIC DIAGRAM. No.6-3

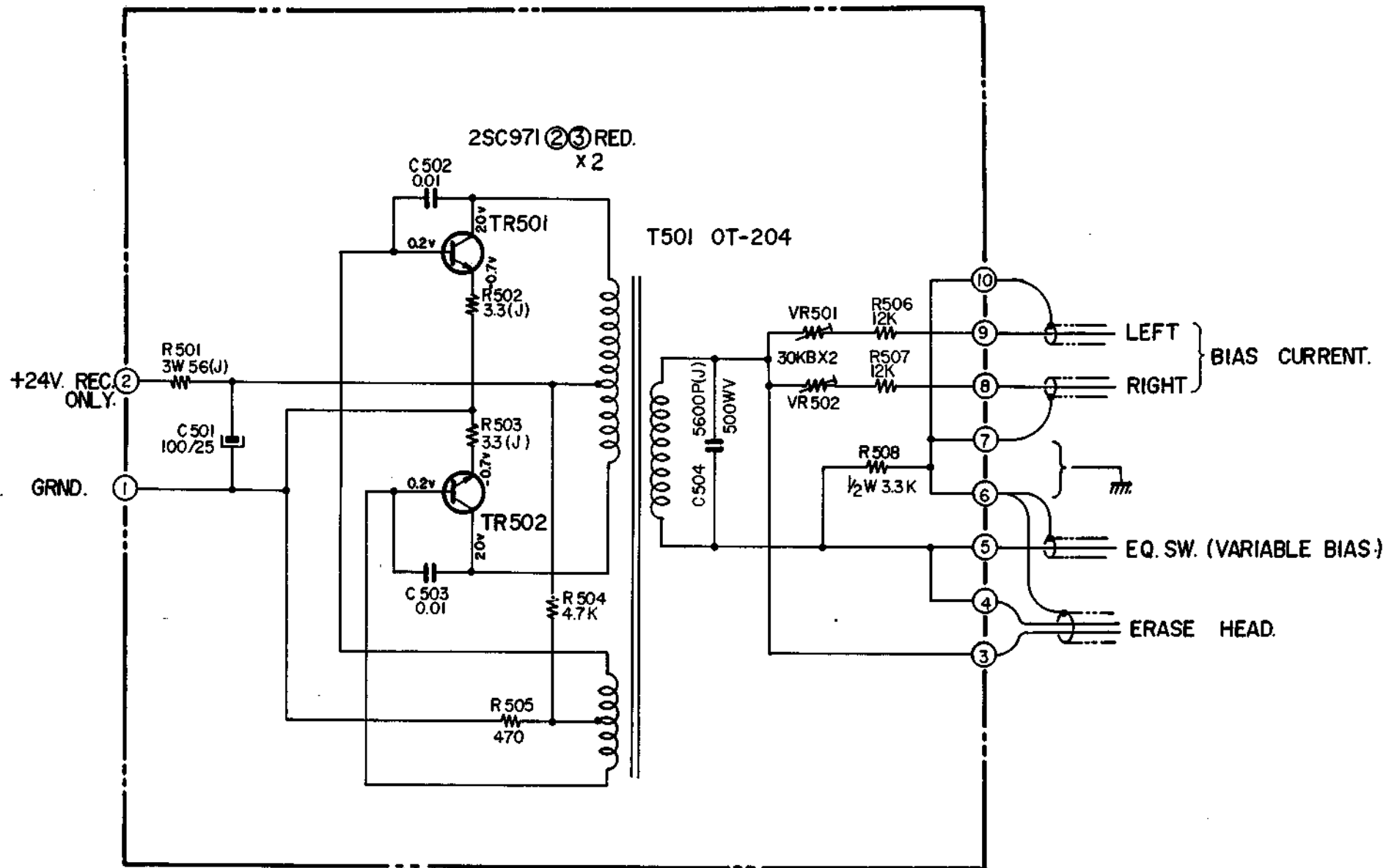

GX-365(D) (BIAS O.S.C.) SCHEMATIC DIAGRAM. No.6-5

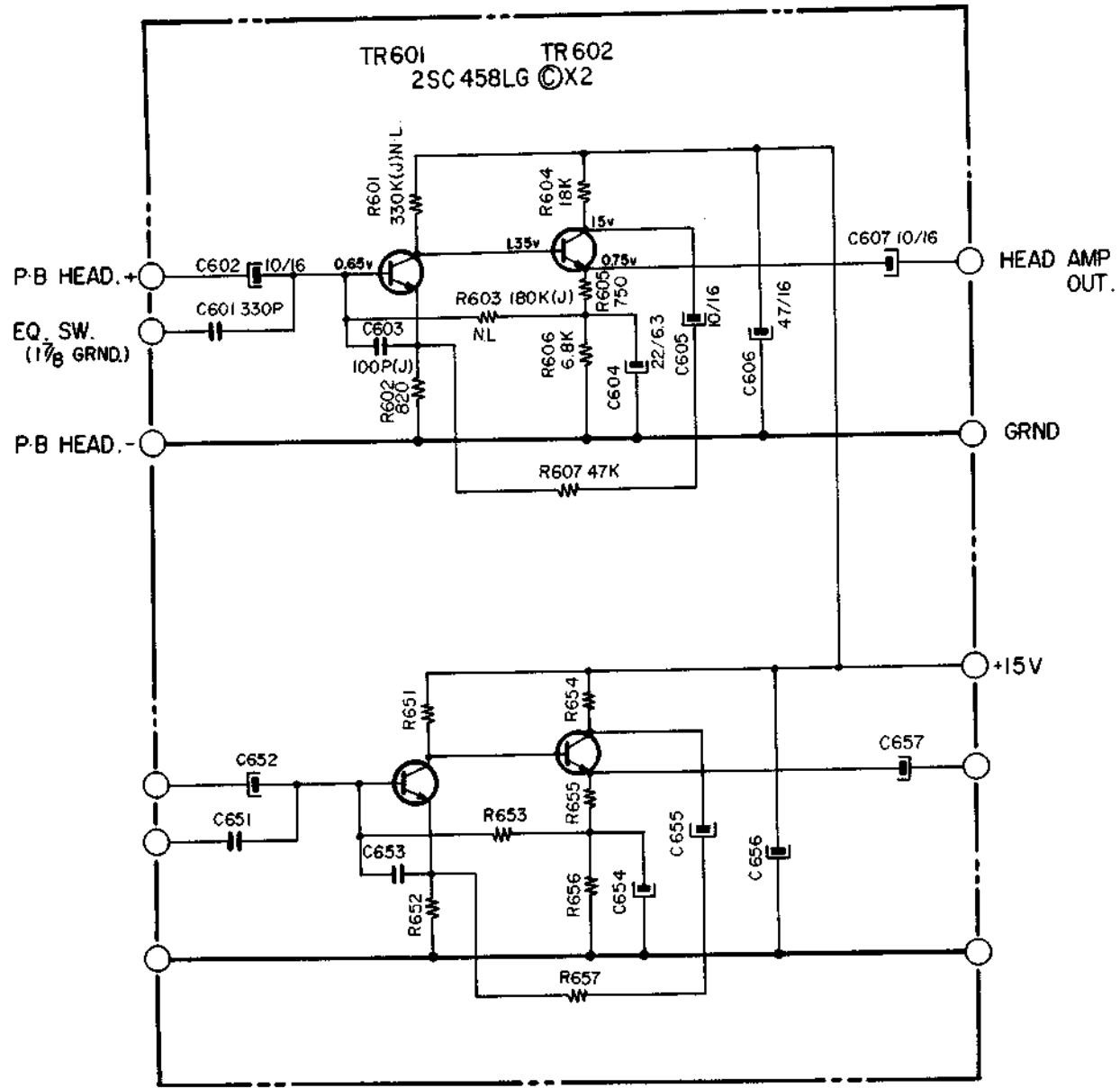

GX-365(D)(HEAD AMP.) SCHEMATIC DIAGRAM No.6-6

SYSTEM CONTROL P.C. BOARD (RD-A211)

For easy repair, patterns of both Sides of this P.C. Board are shown in the Service Manual. By placing the transparent sheet on which (RD-A211B) is shown over pattern (RD-A211), both sides can be seen at same time.

