

202

TEAC®



SERVICE MANUAL

X-700R

Stereo Tape Deck

dbx noise reduction system made under license from dbx Incorporated. The word dbx and the dbx Symbol are trademarks of dbx Incorporated.

202

1 SPECIFICATIONS AND SERVICE DATA

SPECIFICATIONS

Track System ¼-track, 2-channel stereo

Head System

6 heads: forward erase, forward record, reverse playback, forward playback, reverse record, reverse erase.

Reel Size 7"

Tape Speed 19cm/s (7-½ ips) and 9.5cm/s (3-¾ ips)

Inputs (level and impedance)

MIC: Specified input level: -60dB (0.775mV)/10kohms
Min. input level: -70dB (245µV)

LINE IN: Specified input level: -12dB (195mV)/50kohms
Min. input level: -22dB (61.5mV)

Outputs (level and impedance)

OUTPUT: Specified output level: -5dB (436mV)/10kohms
Max. output level: +1dB (0.869V)

PHONES: Specified output level: -24dB (48.9mV)/8ohms

Playback Equalization

19cm/s: 3,180µs + 50µs (NAB), 3,180µs + 35µs (EE)

9.5cm/s: 3,180µs + 90µs (NAB), 3,180µs + 50µs (EE)

Motors

Capstan motor: DC brush motor with FG servo

Reel motor: 2 DC slotless motors

Bias Frequency 100kHz

Operating Position Vertical, horizontal, angled

Power Requirements

100/120/220/240V, AC 50/60Hz, 77W
(General export model)

220V AC 50Hz, 77W (Europe model)

240V AC 50Hz, 77W (U.K./Australia model)

120V AC 60Hz, 77W (U.S.A./Canada model)

Weight 18kg (38-11/16 lbs.) net

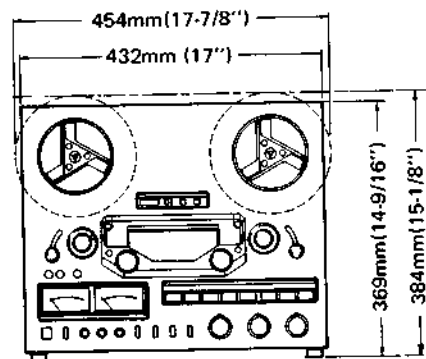

Fig. 1-1 Dimensions

SERVICE DATA

MECHANICAL

Tape Speed Deviation 3,000Hz ± 30Hz

Tape Speed Drift 15Hz

FWD/REV Tape Speed Differential 30Hz

Wow and Flutter

Playback: 0.05% (WRMS), 0.10% (RMS) at 19cm/s
0.07% (WRMS), 0.12% (RMS) at 9.5cm/s

Record/Playback: 0.12% (RMS) at 19cm/s
0.15% (RMS) at 9.5cm/s

Pinch Roller Pressure 1.35kg ~ 1.9kg (3.0 lbs ~ 4.2 lbs)

Reel Torque

Play mode:
Take-up 260 ± 40g-cm (3.1 ~ 4.2oz-inch)

Back tension 180 ± 40g-cm (1.9 ~ 3.1oz-inch)

Fast winding mode:

Take-up: 1100g-cm (15.3oz-inch)

Back tension: 50g-cm (0.7oz-inch)

Brake Torque

Forward direction: 800 ~ 1400g-cm (11 ~ 19oz-inch)

Reverse direction: 500g-cm (6.9oz-inch) or less

Left/right deviation: 200g-cm (2.8oz-inch) or less

Fast Winding Time 150 seconds or less for 550m (1800 feet)

Pitch Control Standard tape speed ±6% or more

FWD/REV Change Time 3.5 sec. ± 0.5 sec.

TIMER Activate Time 4 sec. ± 2 sec.

ELECTRICAL

Frequency Response **Playback:** See Fig. 3-5 to 3-6
Overall: See Fig. 3-7 to 3-8

Signal to Noise Ratio **Playback:** 50 dB min. (19 cm/s, LH)
52 dB min. (19 cm/s, EE)
49 dB min. (9.5 cm/s, LH)
52 dB min. (9.5 cm/s, EE)
Overall: 48 dB min. (19 cm/s, LH)
50 dB min. (19 cm/s, EE)
46 dB min. (9.5 cm/s, LH)
50 dB min. (9.5 cm/s, EE)

Erase Efficiency 68dB min. at 1kHz (measured with input 10dB higher than the specified input level)

Channel Separation 50dB min. at 1kHz

Adjacent Track Crosstalk 40dB min. at 125Hz

Total Harmonic Distortion 0.8% or less at 1kHz

- Improvements may result in SPECIFICATIONS AND SERVICE DATA changes.
- Value of "dB" in the data refers to 0dB (0.775V), except where specified.

⚠ Parts marked with this sign are safety critical components. They must always be replaced with identical components – refer to the TEAC Parts List and ensure exact replacement.

2 MECHANICAL ADJUSTMENTS AND CHECKS

2-1 CONTROL PCB ASSY CHECK

Hooking CONTROL PCB ass'y as shown facilitates this check.

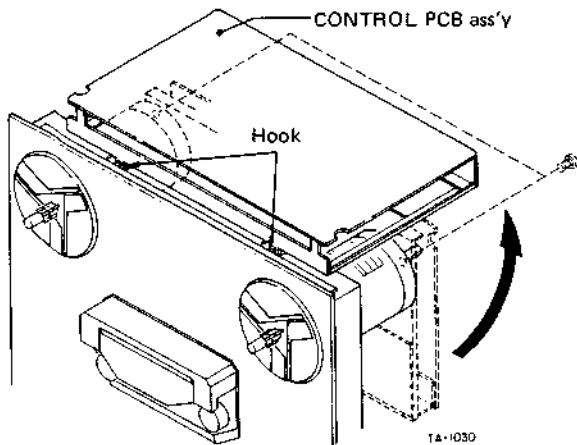

Fig. 2-1

2-2 BRAKE ADJUSTMENT

NOTE: The explanation and figure in this paragraph are for the left side brake, similar checks and adjustments are applicable for the right side one.

1. Adjust by moving the brake band bracket in either direction (arrow (A)) so that the reel motor chassis is in parallel with the brake arm, and so that the brake band makes proper clearance equally all around the reel table base.
2. Adjust by moving the brake solenoid in either direction (arrow (D)) so that the stroke of the solenoid plunger is about 2mm.
3. Adjust by moving the band ass'y retaining plate as shown in (B, C, E) so that, when the plunger is pushed in the direction of the solenoid housing, the reel table base is not rubbed by the brake band and is properly spaced.

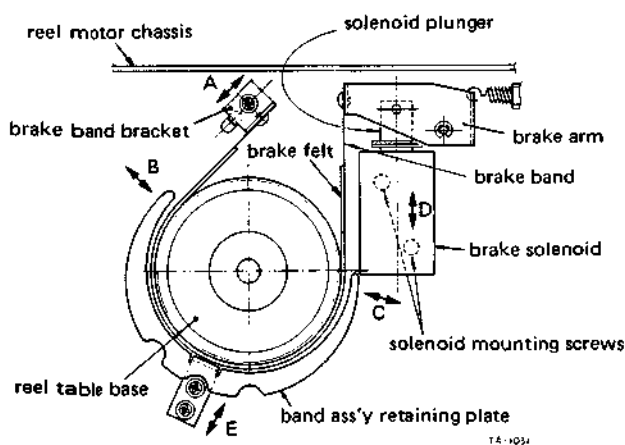
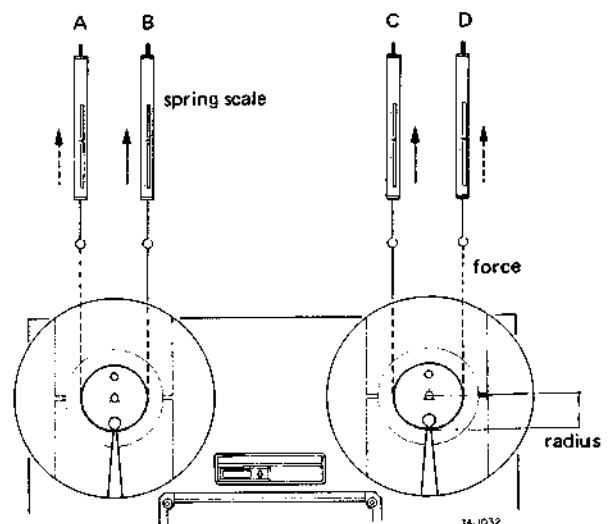

Fig. 2-2

2-3 BRAKE TORQUE MEASUREMENT

1. Place an empty 7" reel, connected to a spring scale by a string, on the reel table.
2. Pull the scale away from the reel and read the scale indication only when the reel table is steady motion.
3. Do steps 1 and 2 for each measuring condition, (A) through (D) in Fig. 2-3.
4. The values are as chart in Fig. 2-3.



Forward direction (B) (C)	800 to 1400g-cm (11 to 19oz-inch)
Reverse direction (A) (D)	500g-cm (6.9oz-inch) or less
Left/right deviation	200g-cm (2.8oz-inch) or less

- NOTES:**
1. The reverse direction values are reference.
 2. The specification of left/right deviation only applies for forward direction torques.

Torque calculating formulas:

- (1) Torque (in g-cm or oz-inch)
= Force or Weight (in g or oz) x Radius (in cm or inch)
- (2) Conversion of g-cm to oz-inch:
g-cm x 0.0139 = oz-inch

Fig. 2-3

2-4 REEL MOTOR TORQUE MEASUREMENT

1. Hold both left and right tension arms in the upper position using rubber bands.
2. See Fig. 2-4. Measure torques for each operating mode with the conditions specified in the chart.
3. Since all the torque values are reference values, it is allowable that the take-up torque during the fast forward or rewind mode is 1kg-cm or more, and that the back tension torque during these mode is good unless the left or right tension arm are shut-off.
4. There is no specially provided adjustment, so if any torque correction are needed, repair or replace defective part(s) and/or circuit(s).

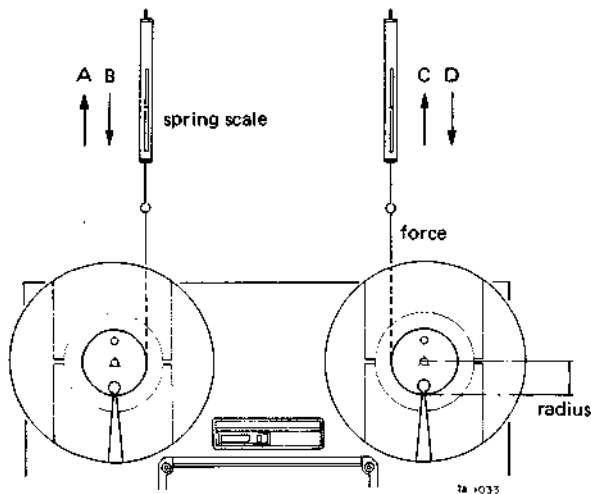

Reel torque reference value

Play mode

Mode	Torque
Take-up: (B) in REV (D) in FWD	260 ± 40g-cm (3.1 ~ 4.2oz-inch)
Back tension: (A) in FWD (C) in REV	180 ± 40g-cm (1.9 ~ 3.1oz-inch)

Fast winding mode

Mode	Torque
Take-up: (B) in REW, (D) in F.F.	1100g-cm (15.3oz-inch)
Back tension: (A) in F.F., (C) in REW	50g-cm (0.7oz-inch)

NOTE: For torque calculation, refer Fig. 2-3.

Fig. 2-4

2-5 PINCH ROLLER PRESSURE STROKE ADJUSTMENT

1. Set the deck in the forward or reverse play mode.
2. Adjust by turning the pressure stroke adj. nut (Fig. 2-5) so that the clearance between the pin and the stopper cushion is about 1.0mm.
3. Since the clearance is produced at one side (left or right), adjustment for this side only is permissible.

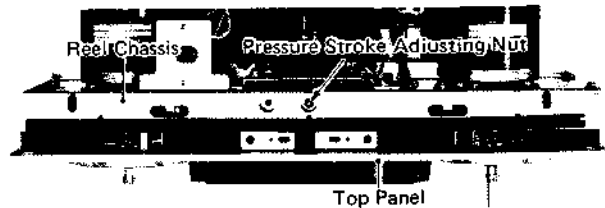
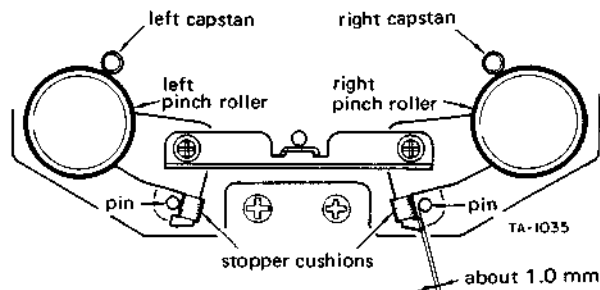

Fig. 2-5 Pinch roller pressure stroke adjustments



Either the left or right should have a clearance of about 1.0mm.

Fig. 2-6

2-6 PINCH ROLLER PRESSURE MEASUREMENT

NOTES: 1. The explanation below applies to both the left and right pinch rollers.

2. Both pinch roller pressures are automatically set with equal value.

1. Hold both the left and right tension arms in the upper positions using rubber bands, string etc.
2. Set the deck in either play mode with no tape loaded.
3. Attach the spring scale to the pinch roller as shown in the figure.
4. Draw the pinch roller away from the capstan shaft (in the direction of a line intersecting the centers of the capstan shaft and the pinch roller) until the capstan shaft and the pinch roller are separated.
5. Return the scale back until the pinch roller just begins to turn. The scale should then be reading as follow.
Reference value: 1.35kg to 1.9kg. (3.0 lbs to 4.2 lbs)
6. If the reading is out of specification, replace defective part(s). There are no adjustable parts.

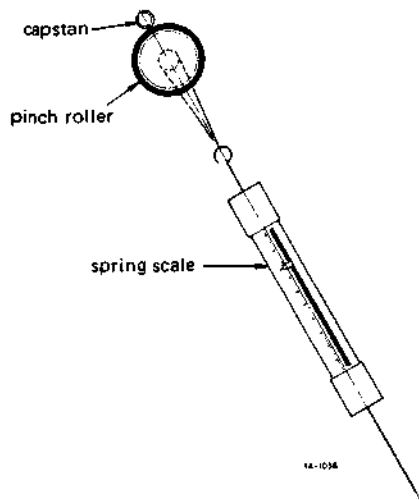

Fig. 2-7

2-7 TENSION ARM HEIGHT ADJUSTMENT

1. Thread any standard tape on the deck using a standard empty reels such as TEAC RE-702.
2. Set the deck in the forward or reverse play mode.
3. Stop left (right) guide roller's rotation by hand. Adjust by turning the left (right) tension arm adjusting nut (refer Fig. 2-8) so that the tape moves in the center of the guide roller.

4. Release the guide roller. Fine-adjust the adjusting nut again until there is no tape curling at the tape guide pin between the erase head and the left (right) guide roller.
5. After adjusting the height of both left and right tension arms, check that the tape running condition is good by repetition of fast forward and rewind modes.
6. If the tape running position is different when the guide roller stops and when it turns, the condition when the guide roller is rotating has priority.

2-8 TENSION ARM FORCE ADJUSTMENT

NOTE: The description below applies to both left and right sides.

1. Check the shut-off switch operates correctly with the deck in the horizontal and vertical positions.
2. Adjustment can be done by changing the hooking position of the tension arm spring against the spring hook.

2-9 DAMPER FUNCTION CHECK

NOTE: The explanation below applies to both left and right sides.

1. Check that the damper string begins to function after the tension arm has moved 10 to 15mm from the lowest position, while the damping function is working, there is a feeling of resistance.
2. Check that the tension arm returns freely from the above position to the lowest position.

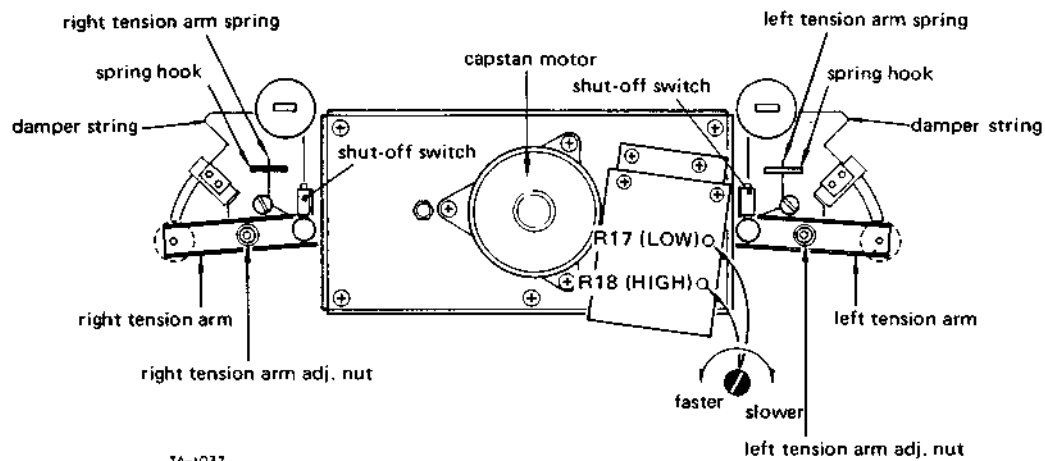

Fig. 2-8 Tension arm height, tension arm force, damper function, and tape speed

2-10 REEL TABLE HEIGHT ADJUSTMENT

1. Adjust the tension arm height beforehand. (See 2-7)
2. Check each reel table height using a TEAC RE-702 empty reel and letting the tape run in each tape operating mode.
3. If the tape rubs against the reel flanges, adjust the reel table height by means of the two reel table mounting screws.

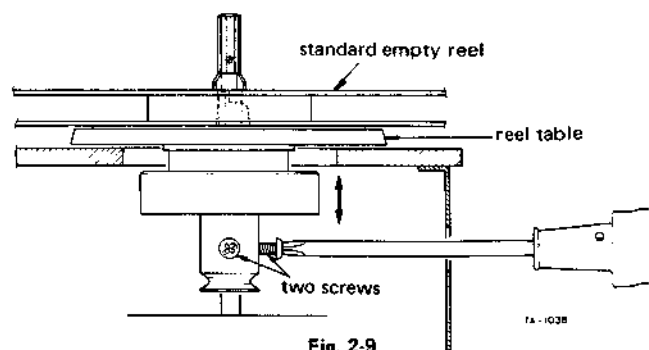
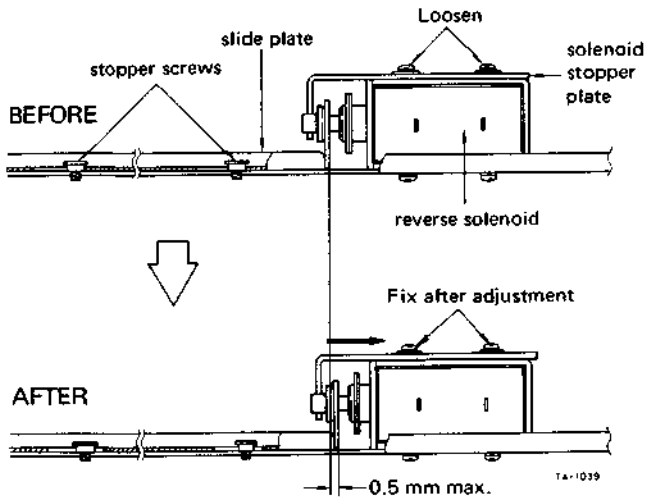

Fig. 2-9

2-11 REVERSE SOLENOID ADJUSTMENT

1. When the reverse solenoid releases, if the slide plate hits the stopper screw/s noisily, the solenoid stopper plate may be adjusted in the direction of the solenoid housing. See illustration.

Parts below are accessible from the rear of the amplifier chassis.



Adjustment range is 0.5mm max. in solenoid-off condition.

Fig. 2-10

2-12 ROTATING PART THRUST CLEARANCE CHECKS

Reference values

Capstan shaft:	0.1mm to 0.25mm (magnefloat type)
Guide roller:	0.05mm to 0.3mm
Tension arm guide roller:	0.05mm to 0.3mm
Reel motor:	0 (spring type)
Tension arm:	0 (spring type)

NOTE: Since the capstan shaft is a magnefloat type, check that it is forced towards the rear of the deck while rotating.

2-13 CAPSTAN MOTOR REPLACEMENT

1. When the capstan motor is replaced, install it with its lead wires and washers as shown.
2. Check that, when the deck is operated by repeating the forward and reverse play modes, the capstan drive belt changes position on the flywheels smoothly.

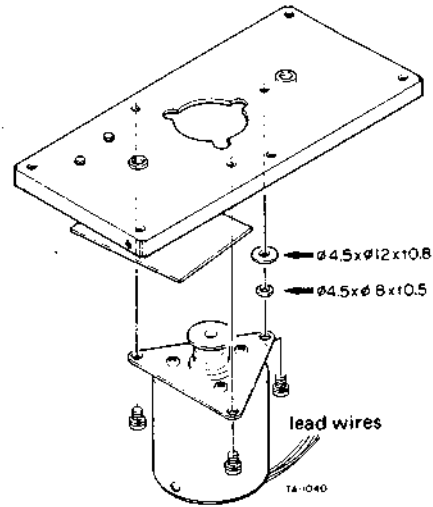

Fig. 2-11

2-14 TAPE SPEED ADJUSTMENT

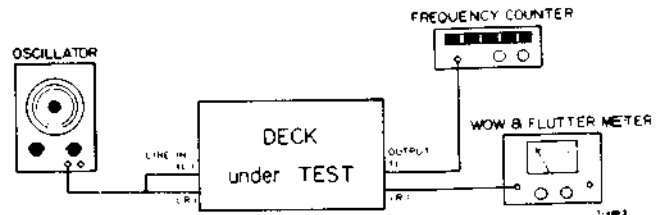

Fig. 2-12

NOTES: 1. Conduct all the following in both forward and reverse play modes.

2. When ordering test tapes, allow for the longer delivery time that is required for them.

1. Connect a frequency counter to either OUTPUT terminal.
2. Load a TEAC YTT-2003 test tape. Set the SPEED switch-HIGH, and PITCH CONT knob OFF.
3. Play the tape. Adjust R18 (see Fig. 2-8) for a reading of 3,000 Hz ± 5 Hz.
4. Check the following at the beginning and the end of the tape.

Specifications:

Tape Speed deviation	3,000Hz ± 3 0Hz
Tape speed drift	1 5Hz
FWD/REV tape speed differential	3 0Hz

5. Change the test tape to a TEAC YTT-2002, and SPEED switch setting to LOW.
6. Repeat steps 3 through 4. Adjust R17 if necessary.
7. Pull the PITCH CONT knob out. Set SPEED switch HIGH. Play a YTT-2003 tape.
8. Check if the speed variation of at least $3,000\text{Hz} \pm 180\text{Hz}$ is obtained when the PITCH CONT knob is rotated fully in both directions.
9. Change the test tape to YTT-2002, SPEED switch setting to LOW. Repeat step 8.

2-15 WOW AND FLUTTER CHECKS

- NOTES:**
1. All the following apply to both forward and reverse play modes.
 2. The following measurements should be made at the beginning and the end of the tape.
 3. When ordering test tapes, allow for the longer delivery time that is required for them.

Playback

1. Connect the test equipment to the deck as shown in Fig. 2-12.
2. Load and play a TEAC YTT-2003 test tape for HIGH speed (19cm/s or 7-½ ips), or a TEAC YTT-2002 test tape for LOW speed (9.5cm/s or 3-¾ ips).
3. Read the indication on the wow and flutter meter.

Specifications:

HIGH speed:	0.05% WRMS
	0.10% RMS
LOW speed:	0.07% WRMS
	0.12% RMS

Overall

4. Load a TEAC YTT-8013 test tape (blank). Apply and record a 3,000Hz signal.
5. During simultaneous tape monitoring (playing) the recorded signal, read the wow and flutter meter display.

Specifications:

HIGH speed:	0.12% RMS
LOW speed:	0.15% RMS

2-16 VOLTAGE CONVERSION (FOR GENERAL EXPORT MODELS)

Always disconnect the power line cord before making these adjustments.

Frequency Conversion

Since the X series uses DC motors, frequency conversion is not necessary.

Voltage Conversion

1. First remove the two feet by removing the screws in each one.
2. Unscrew the left and right sides of the cabinet.
3. Locate the voltage selector to the right of the power transformer as seen from the rear of the deck.
4. Turn the slotted center post of the selector with a screw-driver until the desired voltage numerals appear in the cut-out section of the selector.
5. Replace the cabinet and feed.

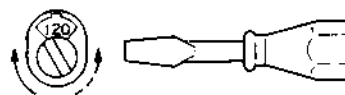

Fig. 2-13

2-17 LUBRICATION

Oiling is needed after every 1,000 hours of operation or once a year if the deck is infrequently used. For this purpose, TEAC spindle oil (from TEAC TZ-255 oil kit), Mobil D.T.E. Oil Light, etc are recommended. Lubrication is normally not necessary except at the points shown.

1. Place the deck in the horizontal position.
2. Apply a few drops of oil to the respective spindles shown, excluding capstans, then spread the oil evenly on the spindle surfaces using a cotton cloth, etc.
3. For capstans, apply a few drops to the indicated position.
4. After oiling all the points, leave the deck for 1 to 2 hours until the oil is thoroughly absorbed.

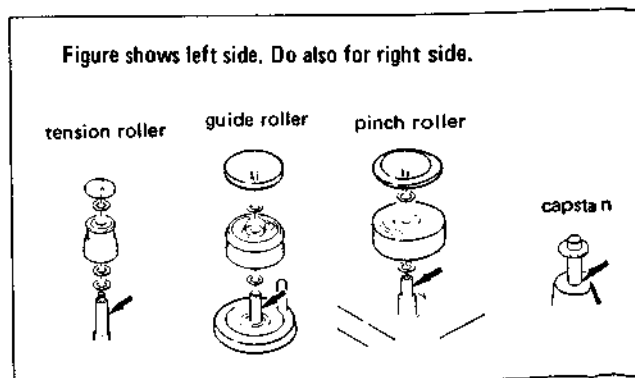

Fig. 2-14

2-18 HEAD AND TAPE PATH ALIGNMENTS

NOTES: 1. For detailed alignment principles, refer to the book "Audio Fundamental -TAPE DECK-, 8. Mechanical Adjustments" published by the TEAC CORPORATION.

Head adjustment screws

Erase	Record and playback
Fixed screws (not adjustable)	⊕ Azimuth ⊕ Height and tilt ⊕ Tangency

2-18-1 HEAD ARRANGEMENT

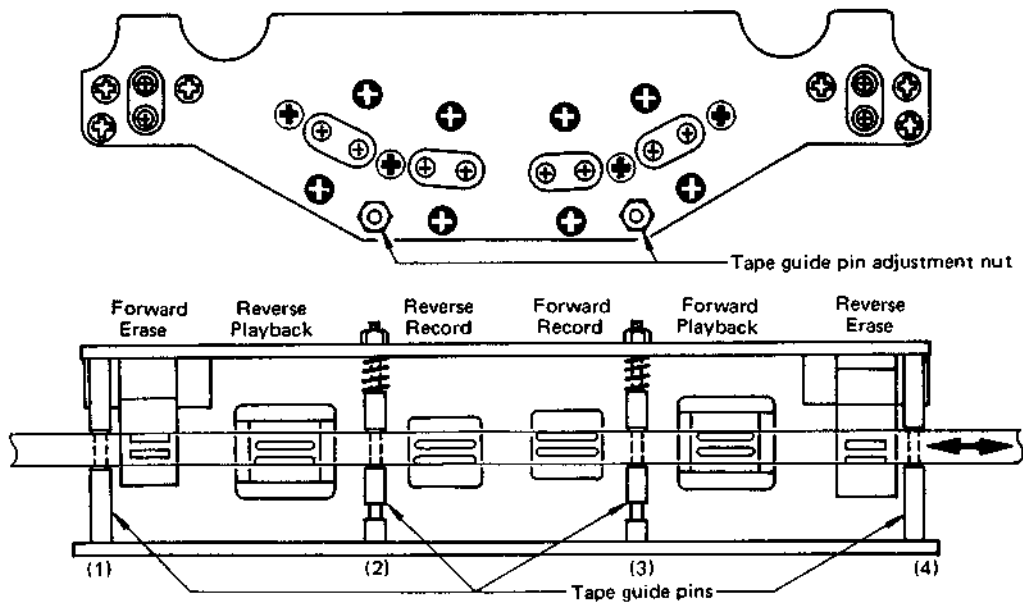

Fig. 2-15 Head arrangement

2-18-2 HEAD REGULATION ELEMENTS

Adjust each head to satisfy each of the following:

<p>TILT The head surface should be parallel to the tape guide pin surface.</p>	
<p>AZIMUTH The gap of the head core should be perpendicular to the tape travel.</p>	
<p>HEIGHT The upper (lower) core of the head should be level with the upper (lower) edge of the tape.</p>	
<p>TANGENCY The dotted line should be perpendicular to the surface of the tape.</p>	

Fig. 2-16 Head regulation elements

2-18-3 ALIGNMENT PROCEDURE

1. Visually adjust the tilt of each record and playback head so that the head surface is parallel to the nearest tape guide pin.
2. Make coarse azimuth adjustments for the record and playback heads by viewing each head from in front (without tape).
3. Running a TEAC YTT-8013 test tape (thickness = 35 μm) in the forward direction, fine-adjust the height of the left tension roller so that the lower edge of the tape is just touching the lower edge of the tape guide pin (1). See Fig. 2-17, then adjust the height of the tape guide pin (2) so that the upper edge of the tape is in contact with the upper edge of the tape guide. Confirm that the adjustments do not cause the tape to curl.
4. Confirm that the forward erase head core protrudes 0.1 mm above the moving tape. If not, replace the head with another one and recheck.
5. Do exactly the same adjustment (steps 3 and 4) for the reverse direction. Substitute the reverse mode for forward play mode.

Fig. shows the forward erase head.

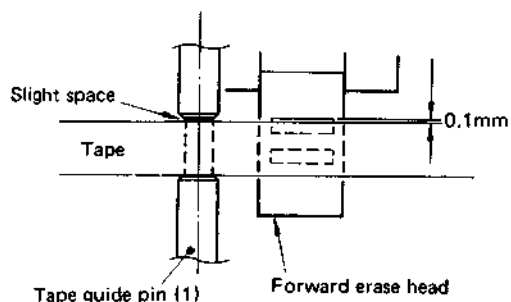

NOTE: In the case of the reverse erase head, the tape should be in contact with the lower surface of the tape guide pin (4).

Fig. 2-17 Erase head height

6. Check for any tape curling at either tape guide pin in the closed loop portion of the tape (i.e., between the capstans).
7. If there is any tape curling at tape guide pin (2) during forward play, do the following: Unthread the tape from the front of the head assembly. Remove both pinch rollers. Set the deck in the play mode. Then visually align the pinch roller spindle with the capstan as described below.

Fig. shows left side.

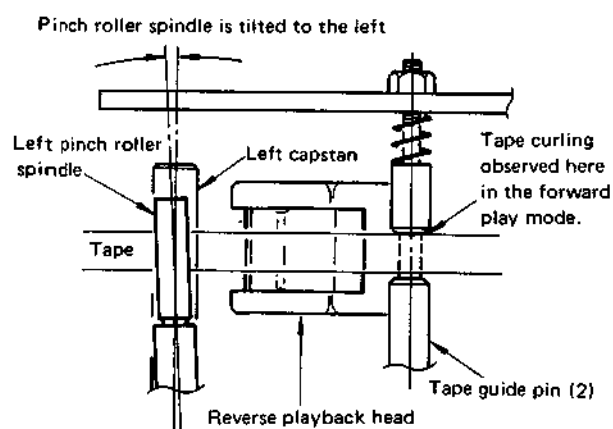

If the pinch roller spindle is tilted to the left (right) with respect to the capstan shaft, tape curling may occur at the upper (lower) edge of the tape guide pin (2).

Fig. 2-18 Example of improperly aligned pinch roller and capstan

8. Loosen the two screws holding the reinforcement plate, then adjust using the correction jig (TEAC P/N 5736000100) as shown in Fig. 2-19.

Note:

- (1) Use the jig as near as possible to the pinch roller spindle.
- (2) Do not touch the surface of spindle.
- (3) Use no other tool for this adjustment!

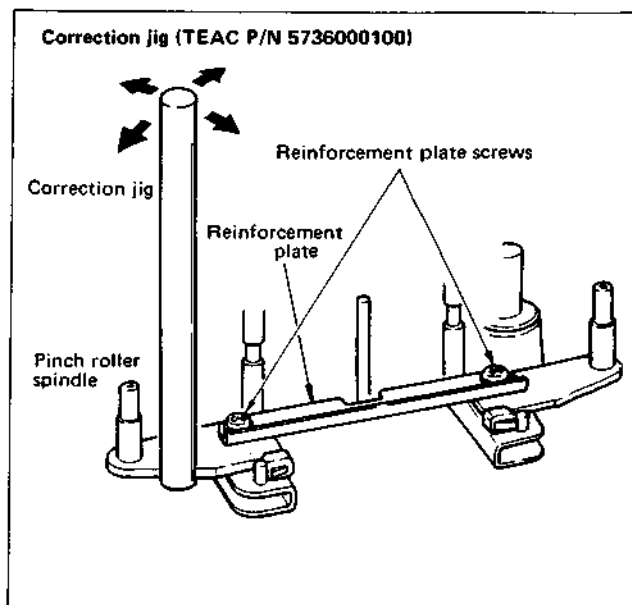
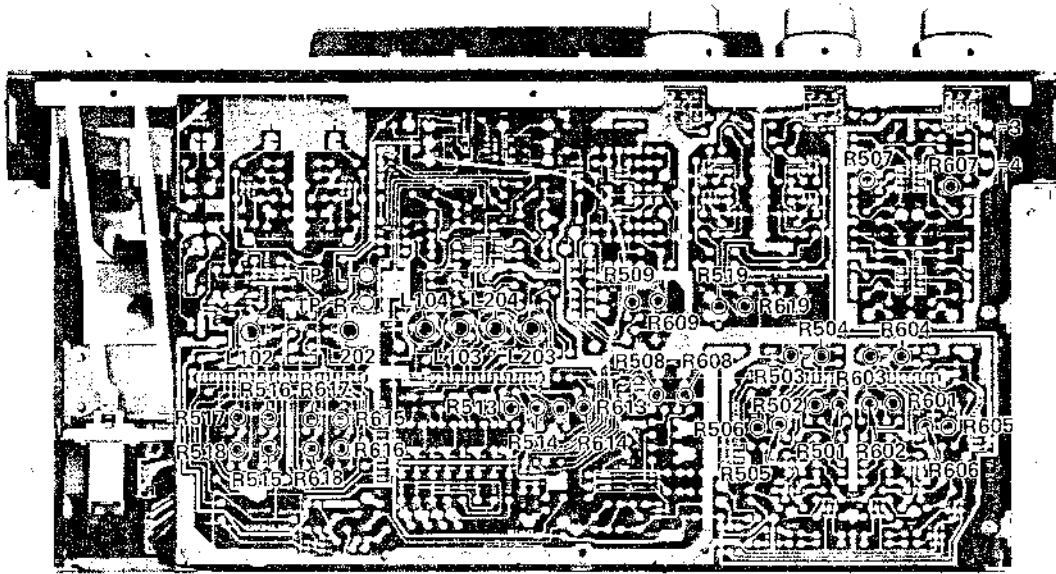

Fig. 2-19 Pinch roller/capstan alignment

9. If the tape curls at tape guide pin (3) in reverse play, correct in the same way (steps 7 and 8).
10. After it is entirely corrected that there is no tape curling condition in the head assembly, fine-adjust each record and playback height so that the brass-colored spacer of forward (reverse) direction purpose head will show above (below) the moving tape. (About as thick as a thin pencil line). Adjustment should be done by equally turning three screws required correction not to disturb tilt and azimuth regulation conducted before.
11. Finally, if necessary, make rough tangency adjustment of respective head with tape running.

3 ELECTRICAL ADJUSTMENTS AND CHECKS

ADJUSTMENT AND TEST POINT LOCATIONS



R501/R601	Playback level (FWD)	R514/R614	Record level (FWD)
R502/R602	Playback level (REV)	R513/R613	Record level (REV)
R503/R603	Playback EQ (HIGH FWD)	R516/R616	Record Bias EE (FWD)
R504/R604	Playback EQ (HIGH REV)	R515/R615	Record Bias EE (REV)
R505/R605	Playback EQ (LOW FWD)	R517/R617	Record Bias LH II (FWD)
R506/R606	Playback EQ (LOW REV)	R518/R618	Record Bias LH II (REV)
R507/R607	Output level	R519/R619	Monitor level
R508/R608	VU meter (playback)	L102/L202	Bias trap (record)
R509/R609	VU meter (monitor)	L103/L203	Record EQ (FWD)
		L104/L204	Record EQ (REV)

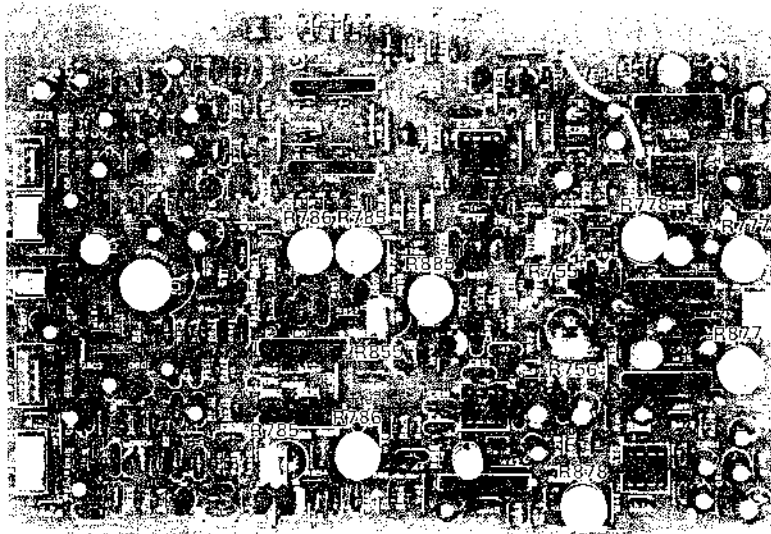

NOTES

1. Before performing adjustments and checks, clean and demagnetize the entire tape path.
2. Check that the deck is properly set for the voltage in your locality.
3. In general, adjustments and checks are done in the order of L-ch then R-ch. Double REF. Nos. indicate L-ch/R-ch. (Example: R509/R609)
4. The value of "dB" refers to 0 dB (0.775 V). If an AC voltmeter calibrated to 0 dB (1 V) is to be used, appropriate compensation should be made.
5. The AC voltmeter used in the procedures must have an input impedance of 1 M-ohms or more.
6. When ordering test tapes, allow for the longer delivery time that is required for them.

3-1 MONITOR PERFORMANCE

ITEM	CONNECTION	MODE/ INSTRUCTION	SIGNAL SOURCE	ADJUST (or CHECK)	RESULT	REMARKS	
1. Monitor level	1-1	OSC → ATT to LINE IN (L) AC voltmeter to REC AND PLAY AMPL. PCB term. #3.	DBX sw—OUT (Leave OUT up to step 24, "DBX PERFORMANCE" section). MONITOR—SOURCE OUTPUT cont.—CAL LINE cont.—MAX MIC cont.—MIN	400 Hz/—22 dB (61.5 mV) R519	—8 dB (308 mV)	LINE min. input level (L)	
	1-2	"	"	400 Hz/—12 dB (195 mV) LINE cont. (L/R)	"	LINE spec. input level (L)	
	1-3	" but LINE IN (L) → LINE IN (R) #3 → #4	LINE spec. input level condition	"	R619	"	LINE spec. input level (R)
	1-4	Fig. 3-1	LINE spec. input level condition	400 Hz/—12 dB (195 mV)	R507/R607	—5 dB (436 mV)	Output level
2. VU meter	2-1	Fig. 3-1	LINE spec. input level condition	400 Hz/—12dB (195 mV) R509/R609	0 VU on VU meter		
3. MIC input level	3-1	Fig. 3-1, but LINE IN → MIC	LINE cont.—MIN MIC cont.—MAX	400 Hz/—70 dB ±2 dB (195 μV ~ 308 μV) Check	—5 dB (436 mV)	MIC min. input level	
	3-2	"	"	400 Hz/—60 dB (0.775 mV) MIC cont. (L/R)	"	MIC spec. input level	
	3-3	Fig. 3-1	LINE cont.—spec. position (Item 1-2) MIC cont.—MIN	—	—	—	IMPORTANT: Do not disturb these cont's during later checks.

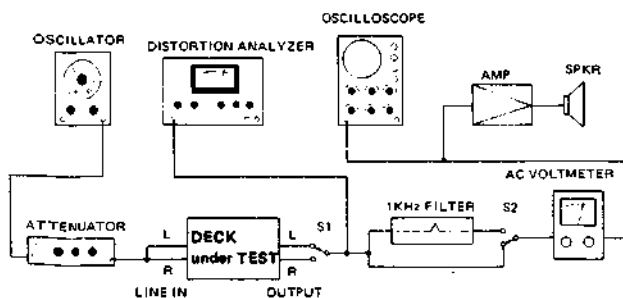

Fig. 3-1 Basic connection

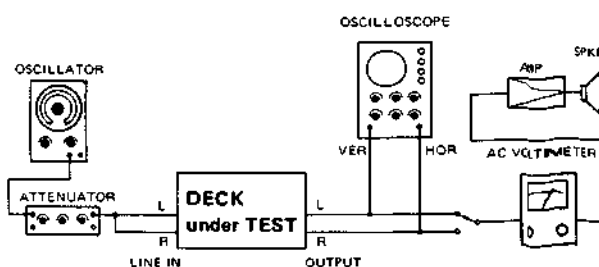

Fig. 3-2 Connection

TEAC test tape: For playback alignment
 YTT-1002: 9.5 cm/s or 3- $\frac{3}{4}$ ips, LHII
 YTT-1003: 19 cm/s or 7- $\frac{1}{2}$ ips, LHII
 YTT-1052: For 9.5 cm/s or 3- $\frac{3}{4}$ ips, EE
 YTT-1053: For 19 cm/s or 7- $\frac{1}{2}$ ips, EE
 For recording alignment (blank)
 YTT-8013: For LHII
 YTT-8053: For EE

3-2 PLAYBACK PERFORMANCE

ITEM	CONNECTION	MODE/ INSTRUCTION	SIGNAL SOURCE	ADJUST (or CHECK)	OUTPUT	REMARKS
4. Playback head azimuth	4-1	Fig. 3-2	Do for both FWD & REV heads MONITOR sw.—TAPE SPEED sw.—HIGH TAPE SELEC.—LHII	YTT-1003 (16 kHz/-10 dB)	Azimuth adj. screw/s of head (Fig. 2-15)	Phase: within 45° on oscilloscope (Fig. 3-3)
5. Playback level	5-1	Fig. 3-1	FWD & REV OUTPUT cont.—CAL SPEED sw.—HIGH	YTT-1003 (400 Hz/0 dB)	R501/R601 (FWD) R502/R602 (REV)	-5 dB (436 mV) Spec. PB condition
	5-2	"	OUTPUT cont.—MAX	"	Check	+1 dB \pm 2 dB (690 mV \sim 1.09 V) Max. output level
	5-3	"	OUTPUT cont.—CAL	"	-	-5 dB (436 mV) Spec. PB condition IMPORTANT: Do not disturb OUTPUT cont. during later checks.
6. VU meter	6-1	Fig. 3-1	FWD Spec. PB condition	YTT-1003 (400 Hz/0 dB)	R508/R608	0 VU on VU meter
7. Frequency response	7-1	Fig. 3-1	FWD & REV TAPE SELEC.—LHII	SPEED-HIGH YTT-1003	R503/R603 (FWD) R504/R604 (REV)	Fig. 3-5
	7-2	"	"	SPEED-LOW YTT-1002	R505/R605 (FWD) R506/R606 (REV)	Fig. 3-6
	7-3	"	FWD & REV TAPE SELEC.—EE	SPEED-HIGH YTT-1053	Check	Fig. 3-5
	7-4	"	"	SPEED-LOW YTT-1052	Check	Fig. 3-6
8. Phase shift	8-1	Fig. 3-2	FWD & REV	SPEED-HIGH YTT-1003	Check	Phase: within 45° on oscilloscope (50 Hz \sim 18 kHz) (Fig. 3-3)
	8-2	"	"	SPEED-LOW YTT-1002	" "	" (50 Hz \sim 10 kHz)
9. Headphone output level	9-1	Fig. 3-4	Spec. PB condition	YTT-1003 (400 Hz/0 dB)	Check	-24 dB \pm 2 dB (38.8 mV \sim 61.5 mV) (at PHONES jack) When OUTPUT terminal is at -5 dB
10. Signal to noise ratio	10-1	Fig. 3-1	FWD & REV LH and EE Spec. PB condition Use fully erased tape (Use bulk tape eraser)	YTT-8013 and YTT-8053	Check	LH, -II HIGH: 50 dB LOW: 49 dB EE HIGH: 52 dB LOW: 52 dB -Ratio of spec. -5 dB and noise -Change-over the polarity of the AC Line plug. The worse reading should be within spec.

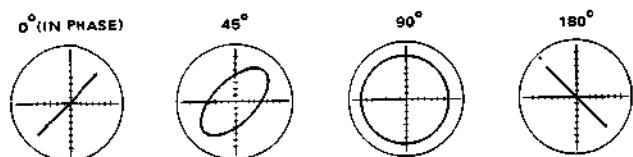

Fig. 3-3 Confirming phase relationship

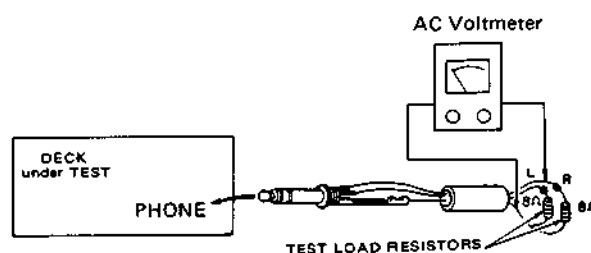

Fig. 3-4 Connection

3.3 RECORDING PERFORMANCE

TEAC test tape: YTT-8013: For recording alignment (blank) for LHII
YTT-8053: For recording alignment (blank) for EE

ITEM	CONNECTION	MODE/ INSTRUCTION	SIGNAL SOURCE	ADJUST (or CHECK)	OUTPUT	REMARKS	
11. Bias trap	11-1	AC voltmeter between BIAS TRAP TP & GND	—	L102/L202	Min. reading	Bias freq., 100 kHz \pm 5 kHz	
	11-2	Fig. 3-1	Rec-pause mode MONITOR sw.—TAPE OUTPUT cont.—CAL	Check	Min. reading —45 dB or more (4.36 mV or less)		
	11-3	"	"	Check	VU: no deflection		
12. Record head azimuth	12-1	Fig. 3-2	Do for both FWD & REV heads MONITOR sw.—TAPE	10 kHz/—32 dB (19.5 mV)	Azimuth adj. screw/s of head (Fig. 2-15)	Phase: within 45° on oscilloscope (Fig. 3-3)	
13. Record bias	13-1	Fig. 3-1	FWD & REV SPEED sw.—LOW MONITOR sw.—TAPE Test tape—YTT-8053 TAPE SELECTOR—EE	7 kHz/—22 dB (61.5 mV)	R516/R616 (FWD) R515/R615 (REV)	Over-bias value 3 dB \pm 1 dB (from peak)	Simultaneous monitoring First set adjustor fully CCW (⤵), then adjust.
	13-2	"	Test tape—YTT-8013 TAPE SELECTOR—LHII	"	R517/R617 (FWD) R518/R618 (REV)	Over-bias value 4 dB \pm 1 dB	
14. Record level	14-1	Fig. 3-1	Same as 13-2 SPEED sw.—HIGH	400 Hz/—12 dB (195 mV)	R514/R614 (FWD) R513/R613 (REV)	—5 dB (436 mV)	Spec. REC condition
15. Distortion	15-1	Fig. 3-1	Same as 13-1 and 13-2, but SPEED sw.—HIGH	1 kHz/—12 dB (195 mV)	Check	0.8% or less (W/LHII, EE)	
16. Signal to noise ratio	16-1	Fig. 3-1	FWD & REV MONITOR sw.—TAPE HIGH & LOW LHII; YTT-8013 EE: YTT-8053	1 kHz/—12 dB (195 mV) then No signal recording	Check	LHII HIGH: 48 dB LOW: 46 dB EE HIGH: 50 dB LOW: 50 dB	Ratio of spec. —5 dB to noise.
17. Erase efficiency	17-1	Fig. 3-1 switch on 1 kHz filter	FWD & REV TAPE SELEC.—EE MONITOR sw.—TAPE SPEED sw.—HIGH YTT-8053 (EE)	1 kHz/—2 dB (615 mV) (+10 dB) then erasing	Check	OUTPUT: —63 dB or more (548 μ V or less) (68 dB min. ratio)	-Reference output level: +5 dB -The worst values should be within spec.
18. REC MUTE function	18-1	Fig. 3-1 switch on 1 kHz filter	FWD & REV Spec. REC condition rec-mute mode	1 kHz/—2 dB (615 mV) (+10 dB) then record muting	Check	OUTPUT: —60 dB or more (0.775 mV or less) (65 dB min. ratio)	-Reference output level: +5 dB -The worst values should be within spec.

ITEM	CONNECTION	MODE/ INSTRUCTION	SIGNAL SOURCE	ADJUST (or CHECK)	OUTPUT	REMARKS	
19. Frequency response	19-1	Fig. 3-1	FWD & REV MONI- TOR sw. -TAPE TAPE SELEC. -EE Test tape -YTT- 8053	Required signal -32 dB (19.5 mV)	L103/L203 (FWD) L104/L204 (REV)	Fig. 3-8	Also it is possible to fine-adjust by the record bias adjustors (See item 13.) if this respective specified record bias setting ranges are kept.
	19-2	"	" SPEED- HIGH	"	Check	Fig. 3-7	
	19-3	"	TAPE SPEED- SELEC. LOW -LHII Test tape -YTT- 8013	"	"	Fig. 3-8	
	19-4	"	" SPEED- HIGH	"	"	Fig. 3-7	
20. Phase shift	20-1	Fig. 3-2	FWD & REV Spec. REC condition SPEED sw.- HIGH	40 Hz ~ 10 kHz/ -32 dB (19.5 mV)	Check	Phase: within 45° on oscilloscope (40 Hz ~ 10 kHz) (Fig. 3-3)	
21. LHI position check	21-1	Fig. 3-1	FWD & REV Spec. REC condition Test tape- YTT-8013 SPEED sw.- HIGH	20 kHz/-32 dB (19.5 mV)	Check	When TAPE SELECTOR sw is changed LHII → LHI, output level should raise +3 dB ± 1 dB	
22. Adjacent track crosstalk	22-1	Fig. 3-1	FWD record. Spec. REC condition SPEED sw.- HIGH TAPE SELECTOR sw.-LHII	125 Hz/-12 dB (195 mV)	-	-	For FWD record.
	22-2	"	REV playback the portion recorded above	-	Check	At both L- and R-ch 125 Hz: -45 dB or more (4.36 mV or less) (40 dB min. ratio)	
	22-3	"	Interchange R & L reels then do FWD playback	-	"	"	
	22-4	Repeat 22-1 through 22-3, but interchange FWD and REV					For REV record.
23. Channel separation	23-1	Fig. 3-1 switch on 1 kHz filter	Same as 22-1	L: 1 kHz/-12 dB (195 mV) R: No signal record.	Check	R, -55 dB or more (1.38 mV or less) (50 dB min. ratio)	For WED record.
	23-2	"	"	L: No signal record. R: 1 kHz/-12 dB	"	L, "	
	23-3	Repeat 23-1 and 23-2 with REV recording.					For REV record.

3-4 FREQUENCY RESPONSE

3-4-1 PLAYBACK

—— LH, YTT-1003
 - - - - EE, YTT-1053

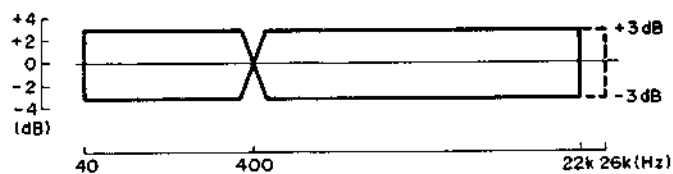

Fig. 3-5 Playback frequency response (19 cm/s)

—— LH, YTT-1002
 - - - - EE, YTT-1052

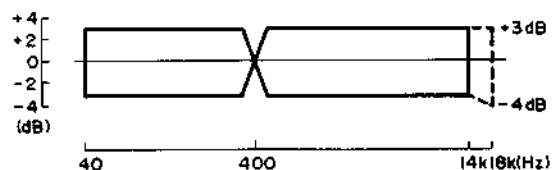

Fig. 3-6 Playback frequency response (9.5 cm/s)

3-4-2 OVERALL

—— LH, YTT-8013
 - - - - EE, YTT-8053



Fig. 3-7 Overall frequency response (19 cm/s)

—— LH, YTT-8013
 - - - - EE, YTT-8053

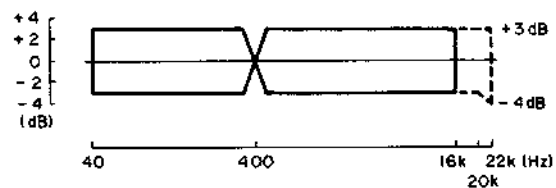

Fig. 3-8 Overall frequency response (9.5 cm/s)

3-5 DBX PERFORMANCE

NOTE:

Test this performance only after you are sure that the "3-6 DBX PCB ADJUSTMENT is correct.

ITEM	CONNECTION	MODE/ INSTRUCTION	SIGNAL SOURCE	ADJUST (or CHECK)	RESULT	REMARKS	
24. Encoder level	24-1	OSC → ATT to LINE IN (both L- & R-ch's) AC voltmeter to REC AND PLAY AMPL. PCB term. #3	DBX sw-OUT MONITOR-SOURCE OUTPUT cont.-CAL LINE cont.-Spec. position (item 1-2) MIC cont.-MIN	1kHz/-12dB (195mV)	Check	-8dB (308mV)	
	24-2	"	Same as above, but DBX sw-IN	"	R855/R856	-8dB ±0.5dB (291mV ~ 327mV)	
	24-3	Repeat 24-1 ~ 24-2 by changing to REC AND PLAY AMPL. PCB term. #4. IMPORTANT: Do not disturb all MIC, LINE and OUTPUT controls during later checks.					
25. Decoder level	25-1	Fig. 3-1	Tape-YTT-8013 DBX sw-OUT SPEED-19cm/s REC MODE-ON TAPE sw-LH-II MONITOR-TAPE	1kHz/-12dB (195mV)	Check	Note the measured output as reference.	
	25-2	"	Same as above but DBX sw-IN	"	R755/R756	±0.5dB deviation from ref.	
26. Frequency response	26-1	Fig. 3-1	Same as 19-1 ~ 19-4, but DBX sw-IN EE YTT-8053 } only	Required signal, -32dB (19.5mV)	Check	19cm/s: 40Hz ~ 20kHz +5, -4dB (Ref.: 400Hz) 9.5cm/s: 40Hz ~ 16kHz +5, -4dB (Ref.: 400Hz)	
27. Signal to noise ratio	27-1	Fig. 3-1	DBX sw-IN REC MODE sw-ON MONITOR-TAPE { LH-II { YTT-8013 { EE { YTT-8053	1kHz/-12dB (195mV) then No signal recording	Check	65dB min. ratio (w/LH-II, EE at all tape speeds)	Ratio of spec. -5dB to noise
28. Distortion	28-1	Fig. 3-1	Same as 27-1	1kHz/-12dB (195mV)	Check	0.8% or less (w/LH-II, EE)	0VU input level
	28-2	"	"	1kHz/+8dB (1.95V)	"	3% or less (LH-II) 6% or less (EE)	20VU input level

3-6 DBX PCB ADJUSTMENT

NOTES:

1. This section adjustment is not usually needed unless a trimmer(s) has been changed or a component(s) on the DBX PCB has sustained damage, since the PCB has been precisely adjusted in the factory.
2. Disconnect all connectors on the DBX PCB, except for J901/P901. Turn the deck OFF to prevent accidental damage when disconnecting or reconnecting.

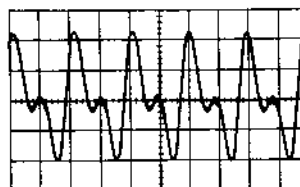

Fig. 3-9 RMS symmetry adjustment (incorrect)

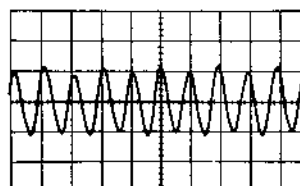

Fig. 3-10 RMS symmetry adjustment (correct)

3-6-1 ENCODER ADJUSTMENT

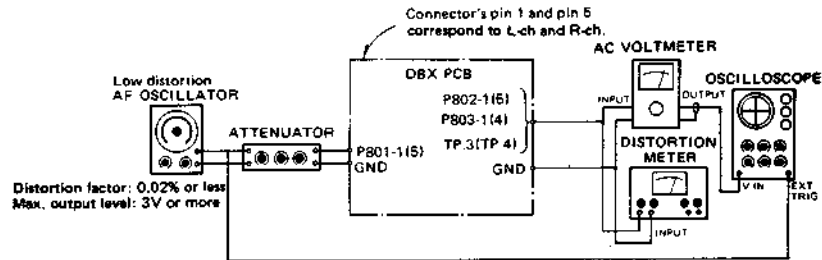

Fig. 3-11 Encoder adjustment setup

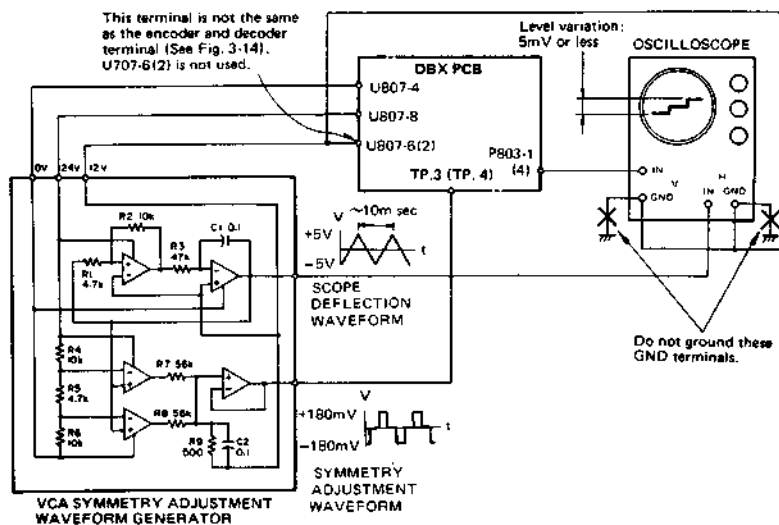

Fig. 3-12 VCA symmetry adjustment setup (encoder)

ITEM	STEP	INPUT INSTRUCTION	ADJUST (or CHECK)	MEASURING POINT: RESULT	REMARKS
1. Preparation	1	Prepare test setup as shown on Fig. 3-11.			
	2	Preset each of the trimmers of the encoder section on the PCB to their approximate center positions.			
2. Input setting	3	Apply 100Hz level to get RESULT value.	Attenuator	P802-1(5): 300mV (-8.2dB)	
3. RMS symmetry	4		R877/R878	TP3(TP4): Clean 200Hz sine-wave	Refer to Figs. 3-9 and 3-10.
4. RMS time constant	5		Check	TP3(TP4): 385μV (-66.1dB) ±20%	
5. Encoder nominal level	6	Apply 1kHz level to get RESULT value.	Attenuator	P802-1(5): 300mV (-8.2dB)	
	7		R855/R856	P803-1(4): 300mV (-8.2dB) *1	*1 Reference 1
6. VCA symmetry	8	Change test setup to as Fig. 3-12, then adjust. Shortcircuit between P801-1(5) and P801-2.	R885/R886	P803-1(4): A relatively straight horizontal line on the 'scope face'. (Level variation: 5mV or less)	

ITEM	STEP	INPUT INSTRUCTION	ADJUST (or CHECK)	MEASURING POINT: RESULT	REMARKS
7. Frequency response	9	Return to Fig.3-11 test setup. Change oscillator frequency to 100Hz.	Check	P803-1(4): -2.5dB \pm 0.5dB against Ref. 1. (212mV ~ 238mV)	
	10	Change oscillator frequency to 10kHz.	Check	P803-1(4): -4.7dB \pm 0.5dB against Ref. 1. (165mV ~ 185mV)	
8. Encoder effect-1	11	Apply 1kHz level*2 to get RESULT value.	Attenuator	P803-1(4): 300mV (-8.2dB)	*2 Reference 2
	12	Apply 1kHz at -60dB against Ref. 2.	Check	P803-1(4): -30dB \pm 0.5dB against Ref. 1. (8.96mV ~ 10.1mV)	
9. Encoder effect-2	13	Apply 1kHz at +20dB against Ref. 2.	Check	P803-1(4): +10dB \pm 0.5dB against Ref. 1. (0.896V ~ 1.01V) Distortion: 0.3% or less	

3-6-2 DECODER ADJUSTMENT

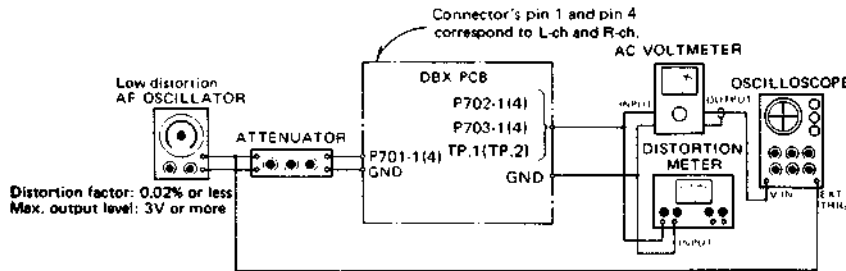

Fig. 3-13 Decoder adjustment setup

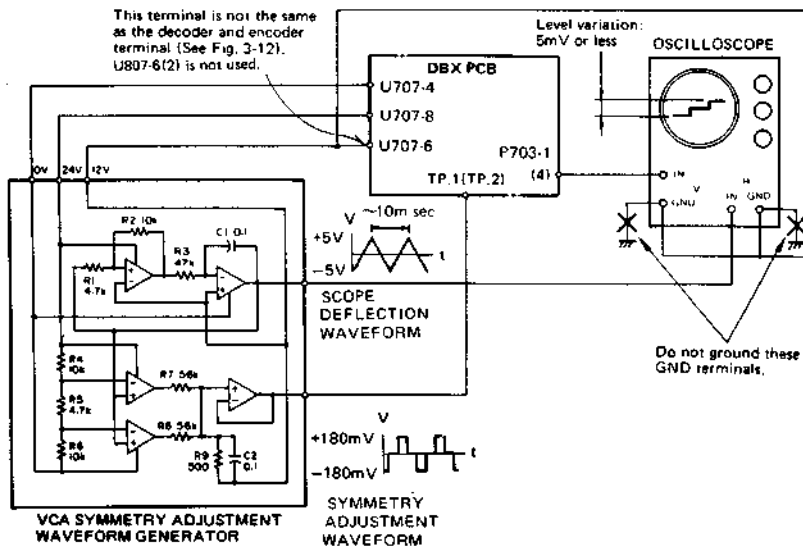
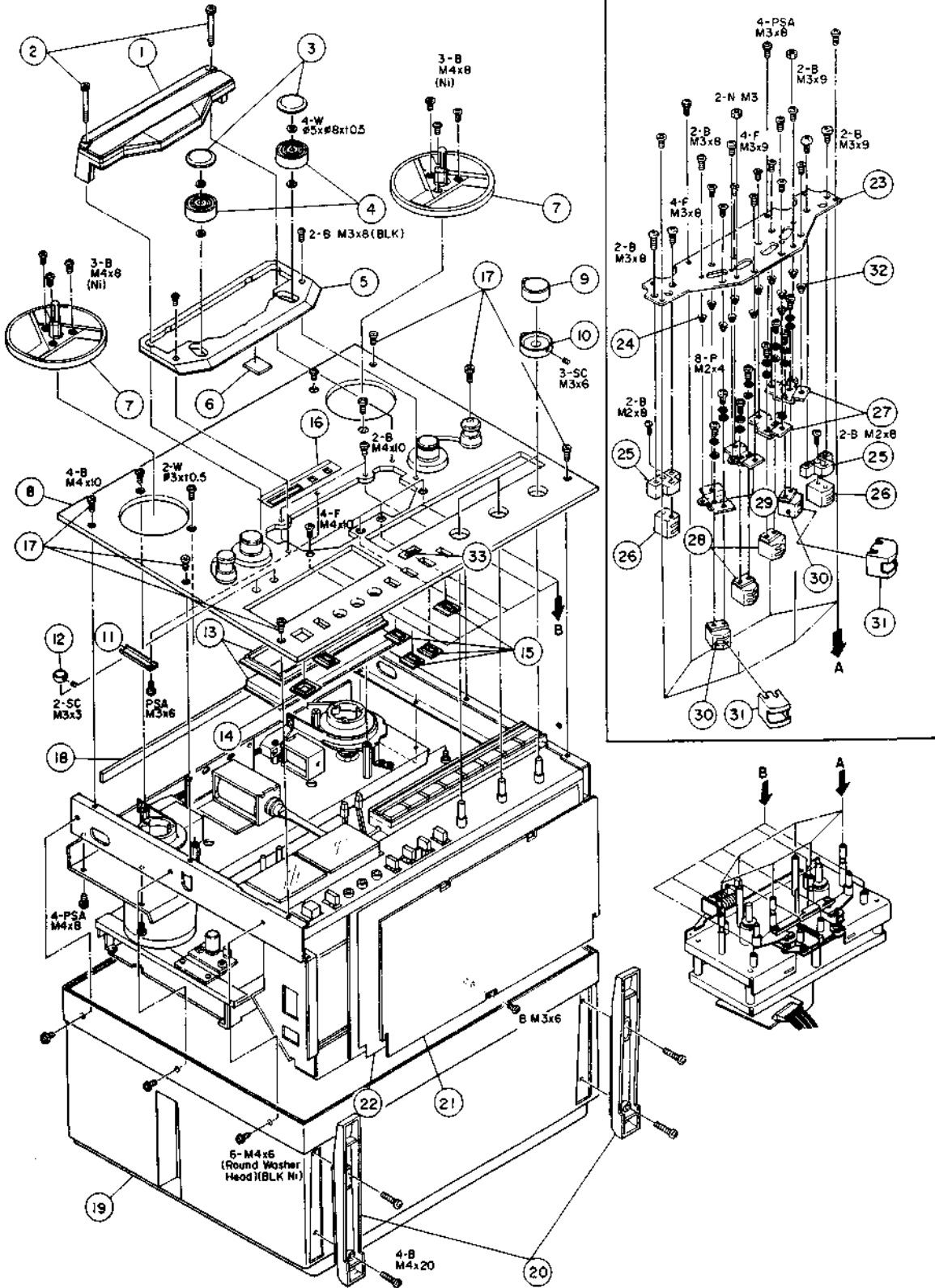

Fig. 3-14 VCA symmetry adjustment setup (decoder)

ITEM	STEP	INPUT INSTRUCTION	ADJUST (or CHECK)	MEASURING POINT: RESULT	REMARKS
1. Preparation	1	Prepare test setup as shown on Fig. 3-13.			
	2	Preset each of the trimmers of the decoder section on the PCB to their approximate center positions.			
2. Input setting	3	Apply 100Hz level to get RESULT value.	Attenuator	P702-1(4): 300mV (-8.2dB)	
3. RMS symmetry	4		R777/R778	TP1(TP2): Clean 200Hz sine-wave	Refer to Figs. 3-9 and 3-10.
4. RMS time constant	5		Check	TP1(TP2): 385 μ V (-66.1dB) \pm 20%	
5. Decoder nominal level	6	Apply 1kHz level to get RESULT value.	Attenuator	P702-1(4): 300mV (-8.2dB)	
	7		R755/R756	P703-1(4): 300mV (-8.2dB) *1	*1 Reference 1
6. VCA symmetry	8	Change test setup to as Fig. 3-14 then adjust. Shortcircuit between P701-1(4) and P701-2.	R785/R786	P703-1(4): A relatively straight horizontal line on the 'scope face'. (Level variation: 5mV or less)	
7. Frequency response (X-1000M)	9	Return to Fig. 3-13 test setup. Change oscillator frequency to 100Hz.	Check	P703-1(4): +5dB \pm 1dB against Ref. 1. (476mV ~ 599mV)	
	10	Change oscillator frequency to 10kHz.	Check	P703-1(4): +9.4dB \pm 1dB against Ref. 1. (789mV ~ 994mV)	
8. Decoder effect-1	11	Apply 1kHz level *2 to get RESULT value.	Attenuator	P703-1(4): 300mV (-8.2dB)	*2 Reference 2
	12	Apply 1kHz at -30dB against Ref. 2.	Check	P703-1(4): -60dB \pm 1dB against Ref. 1. (267 μ V ~ 337 μ V)	
9. Decoder effect-2	13	Apply 1kHz at +10dB against Ref. 2.	Check	P703-1(4): +20dB \pm 1dB against Ref. 1. (2.67V ~ 3.37V) Distortion: 0.2% or less	

4 EXPLODED VIEWS AND PARTS LIST

EXPLODED VIEW-1



REF. NO.	PARTS NO.	DESCRIPTION	COMMON MODELS	REMARKS
1 - 1	*5800516100	Housing Assy, Head		
1 - 2	*5800285000	Screw, Cap	X-1000R	
1 - 3	5545014000	Cap, Pinch Roller	X-10R	
1 - 4	5014175100	Pinch Roller	A-2300	
1 - 5	*5800261900	Base, Head Housing	X-1000R	
1 - 6	*5800002700	Cushion, Head Base	X-10R	
1 - 7	5504744000	Reel Table Assy	X-10R	
1 - 8	*5800513700	Panel, Front		
1 - 9	5800262800	Knob, VR; M	X-1000R	
1 - 10	5800262900	Knob, VR; N	X-1000R	
1 - 11	*5555698000	Plate, Escutcheon Pressure	X-10R	
1 - 12	5800512400	Knob, VR		
1 - 13	*5800512300	Cover Assy, VU Meter		
1 - 14	*5534707000	Escutcheon, Power Switch	X-10R	
1 - 15	*5534706001	Escutcheon, Button	X-10R	
1 - 16	*5800511900	Escutcheon, Counter; N		
1 - 17	5581067000	Screw, Cap; B		
1 - 18	*5555887001	Cushion; Case	X-10R	
1 - 19	*5800055001	Case; S	X-7	
1 - 20	5533190000	Foot	X-10R	
1 - 21	*5553306000	Plate, Ampl. Shield	X-7	
1 - 22	*5553308001	Paper, Ampl. Insulating	X-10R	
1 - 23	*5553289100	Plate, Head Base	X-10R	
1 - 24	5520182000	Spring; D	A-5300	
1 - 25	*5800285300	Spacer, Erase Head	X-1000R	
1 - 26	5378300800	Head, Erase		
1 - 27	*5555673000	Bracket, Head; R	X-10R	
1 - 28	5378300700	Head, Playback; 4T2ch	X-20R "EE"	
1 - 29	*5555672000	Bracket, Head; L	X-10R	
1 - 30	5378300600	Head, Record; 4T2ch	X-20R "EE"	
1 - 31	*5800384501	Head Shield	X-1000R	
1 - 32	5022050000	Spring, B		
1 - 33	*5800512500	Lens, DBX		

INCLUDED ACCESSORIES

REF. NO.	PARTS NO.	DESCRIPTION	COMMON MODELS	REMARKS
	5350008500	Cord, Input-Output Connection		
	5085008300	Empty Reel, 7inch		
	*5062962000	Splicing Tape		
	*5101337100	Open Reel Supplement [U]		
	*5101708000	Open Reel Supplement [All except U]		
	*5700048500	Owner's Manual		

Parts marked with *require longer delivery time.

[U] : U.S.A.

[A] : AUSTRALIA

[C] : CANADA

[E] : EUROPE

[GE] : GENERALE XPORT

[UK] : U.K.

EXPLODED VIEW-2

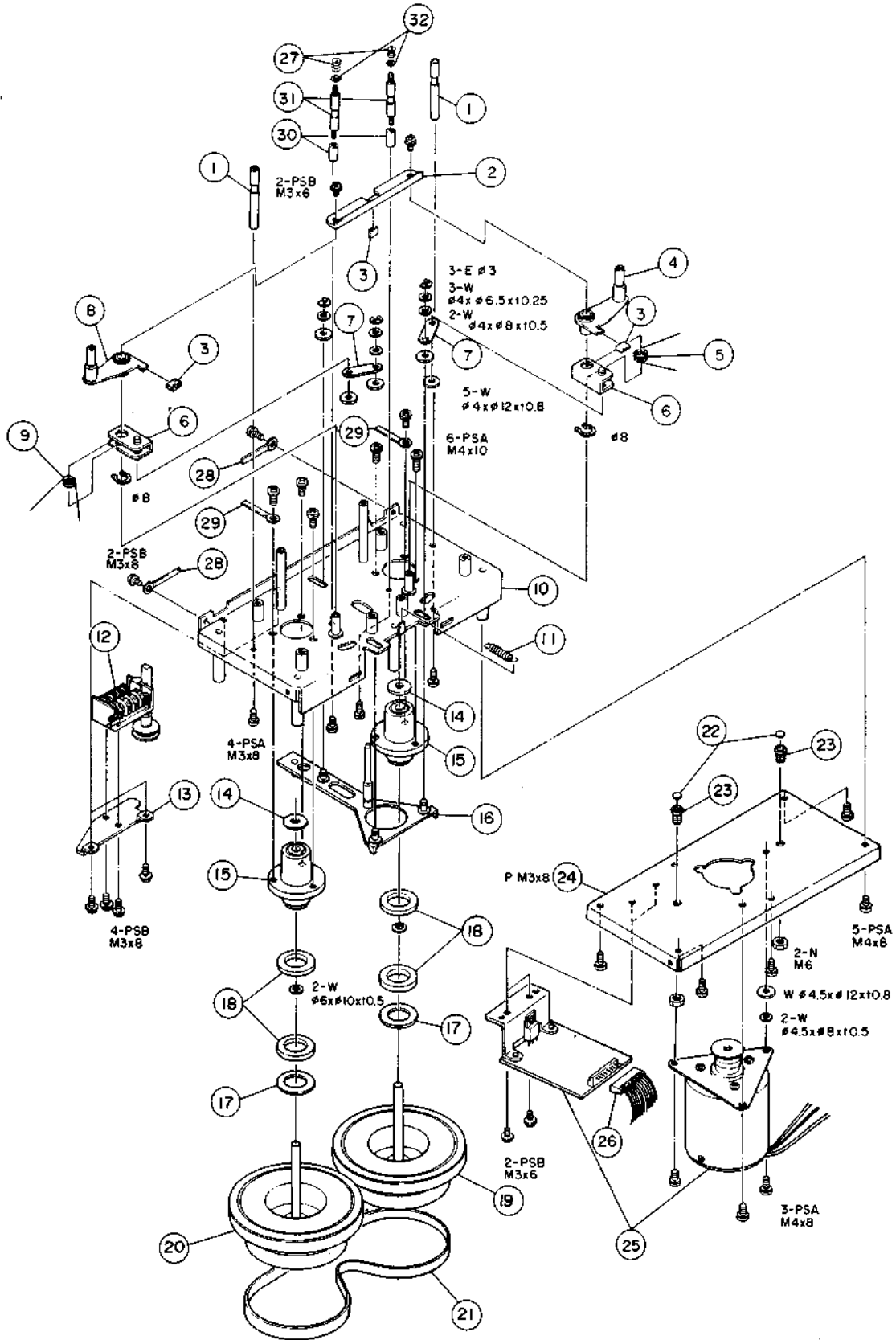

REF. NO.	PARTS NO.	DESCRIPTION	COMMON MODELS	REMARKS
2 - 1	5545023001	Pin, Tape Guide	X-10R	
2 - 2	*5555666000	Plate, Reinforcement	X-10R	
2 - 3	*5534694000	Cushion, Stopper	X-10R	
2 - 4	5504729000	Arm Assy, Pinch Roller; R	X-10R	
2 - 5	5524216000	Spring, Pinch Roller; R	X-10R	
2 - 6	*5504731000	Arm Assy, Pressure	X-10R	
2 - 7	*5555667000	Plate, Joint	X-10R	
2 - 8	5504730000	Arm Assy, Pinch Roller; L	X-10R	
2 - 9	5524217000	Spring, Pinch Roller; L	X-10R	
2 - 10	*5503196000	Base Assy, Capstan	X-10R	
2 - 11	5524219000	Spring, Slide Plate	X-10R	
2 - 12	5504724000	Counter Assy; A	X-10R	
2 - 13	*5555665000	Bracket, Counter	X-10R	
2 - 14	*5534695000	Washer, Oil Retaining	X-10R	
2 - 15	5504726100	Housing Assy, Capstan Flywheel	X-10R	
2 - 16	*5504733001	Plate Assy, Slide	X-10R	
2 - 17	5555704000	Tape, Adhesive	X-10R	
2 - 18	*5534715000	Ring, Magnet; Thrust	X-10R	
2 - 19	5504727000	Flywheel Assy, Capstan; R	X-10R	
2 - 20	5504728000	Flywheel Assy, Capstan; L	X-10R	
2 - 21	5534692001	Blet, Capstan Drive; 4T	X-10R	
2 - 22	*5555703000	Washer, Thrust	X-10R	
2 - 23	*5544003000	Screw, Bearing	A-7300	
2 - 24	*5553290001	Bracket, Motor Mounting	X-10R	
2 - 25	7105018003	DC Motor Assy, Capstan	X-7R	
2 - 26	*5122172000	Connector Socket, 10P		
2 - 27	5800285600	Spring, Guide	X-1000R	
2 - 28		Clamper, Cord; ϕ 3		
2 - 29		Clamper, Cord; ϕ 4		
2 - 30	*5800285500	Support, Guide	X-1000R	
2 - 31	5800285400	Tape Guide	X-1000R	
2 - 32	*5800286100	Washer		

Parts marked with *require longer delivery time.

[U] : U.S.A.

[C] : CANADA

[GE] : GENERAL EXPORT

[A] : AUSTRALIA

[E] : EUROPE

[UK] : U.K.

EXPLODED VIEW-3

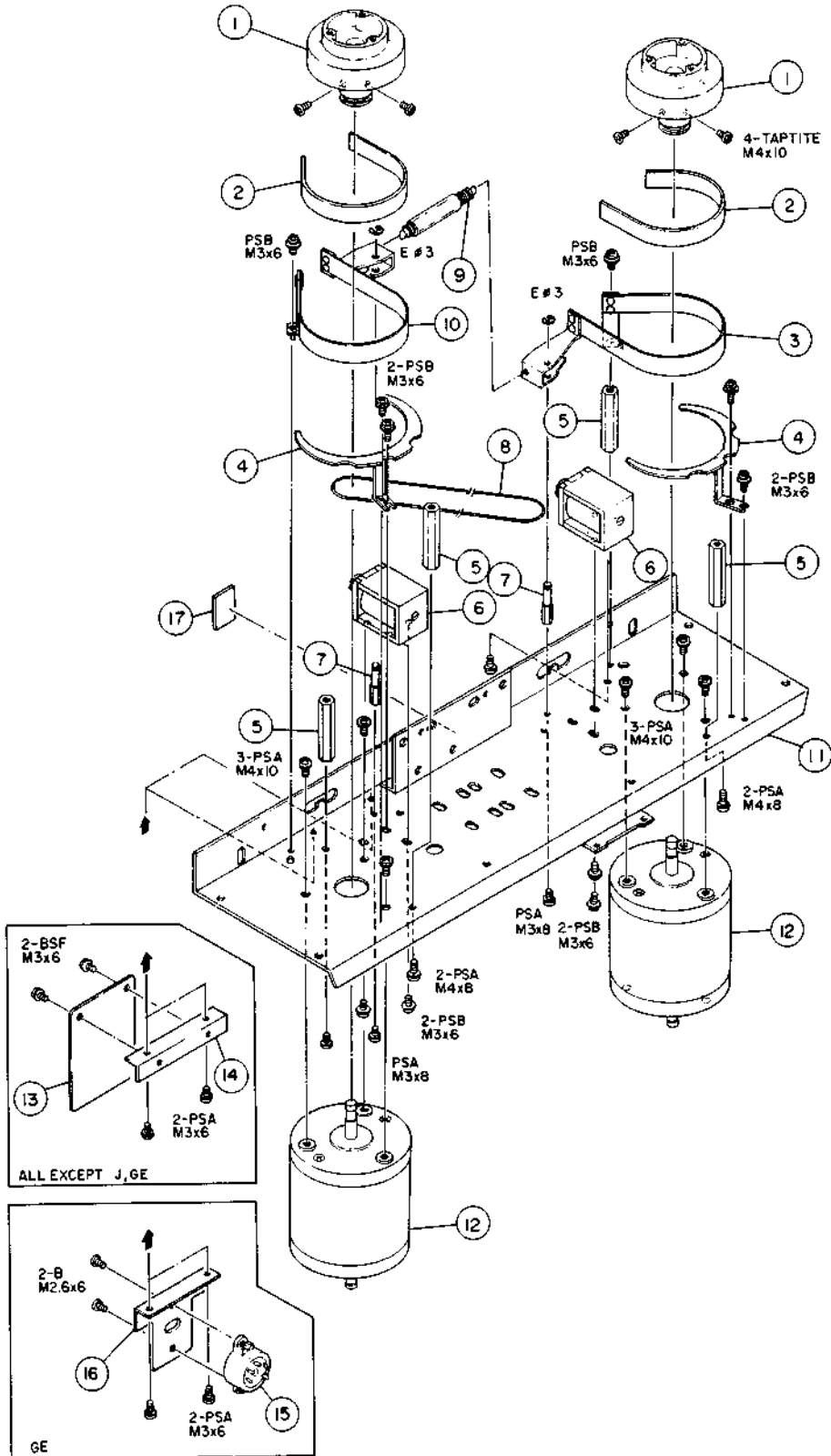

REF. NO.	PARTS NO.	DESCRIPTION	COMMON MODELS	REMARKS
3 - 1	5800346200	Base, Reel Table; B	X-1000R	
3 - 2	5555274000	Shoe, Brake	A-3300SX	
3 - 3	5504736000	Band Assy, Brake; R	X-10R	
3 - 4	*5555685000	Plate, Band Assy Retaining	X-10R	
3 - 5	*5544916000	Stay, Top Panel	A-6100Mkl I	
3 - 6	5163044000	Solenoid, Brake		
3 - 7	*5545033000	Shaft, Brake Band	X-10R	
3 - 8	5027759000	Blet, Counter	A-7030	
3 - 9	5524294000	Spring, Brake	X-10R	
3 - 10	5504735000	Band Assy, Brake; L	X-10R	
3 - 11	*5503194002	Chassis Assy, Reel Motor	X-10R	
3 - 12	5370003300	DC Motor, Reel	X-1000R	
3 - 13	*5168997000	PCB Assy, FUSE [U, C]		
	*5158105000	PCB Assy, FUSE [E, UK, A]		
3 - 14	*5555789000	Bracket, FUSE PCB Assy [U, C, E, UK, A]	X-10	
3 - 15	Δ*5131007001	Voltage Selector [GE]		
3 - 16	*5555790000	Bracket, Voltage Selector [GE]	X-10	
3 - 17	*5555570000	Cushion	X-10R	

Parts marked with *require longer delivery time.

[U] : U.S.A.

[A] : AUSTRALIA

[C] : CANADA

[E] : EUROPE

[GE] : GENERAL IMPORT

[UK] : U.K.

EXPLODED VIEW-4

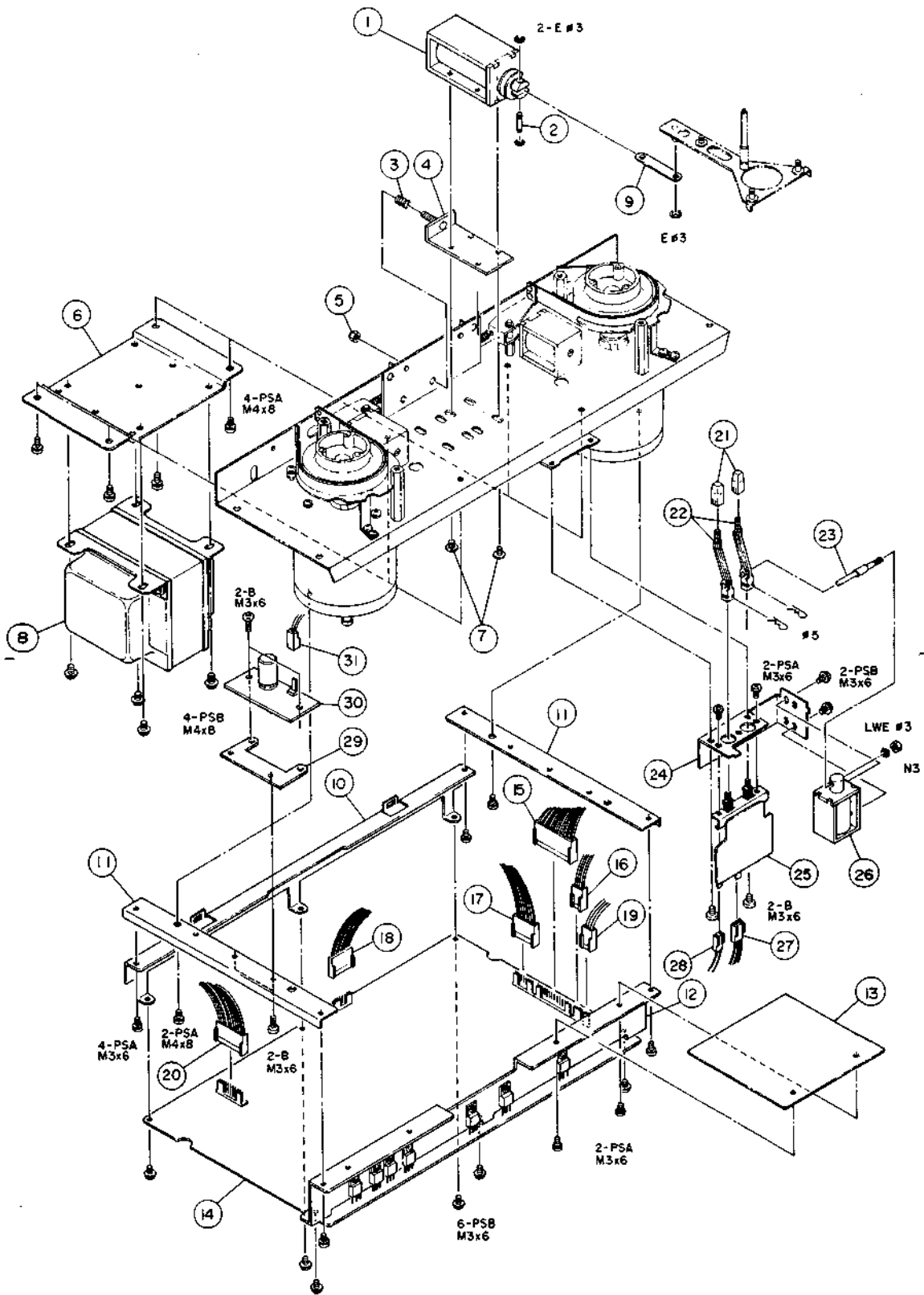

REF. NO.	PARTS NO.	DESCRIPTION	COMMON MODELS	REMARKS
4 - 1	5163041001	Solenoid, Pinch Roller		
4 - 2	*5545022000	Pin, Solenoid	X-10R	
4 - 3	5524218000	Spring, Pinch Roller Pressure	X-10R	
4 - 4	*5504732000	Plate Assy, Solenoid	X-10R	
4 - 5	*5581066000	Nut, Nylon; M4	X-10R	
4 - 6	*5555681101	Bracket, Power Transformer		
4 - 7	*5800022600	Screw, Shoulder; G	X-10R	
4 - 8	△ 5320026200	Transformer, Power [U, C]		
	△ 5320026300	Transformer, Power [E, UK, A]		
	△ 5320006600	Transformer, Power [GE]	X-10R	
4 - 9	*5555676000	Plate, B	X-7R	
4 - 10	*5552390000	Frame, PCB	X-10R	
4 - 11	*5553296001	Frame, Joint	X-10R	
4 - 12	*5552391000	Frame, H.S	X-10R	
4 - 13	*5555888000	Heat Sink, C	X-10R	
4 - 14	*5200004603	PCB Assy, CONTROL [C]	X-7R	
	*5200004614	PCB Assy, CONTROL [E, UK, A]	X-7R	
	*5200004624	PCB Assy, CONTROL [GE]	X-7R	
	*5200004630	PCB Assy, CONTROL [U]	X-7RMk I I	
4 - 15	*5122177000	Connector Socket, 15P		
4 - 16	*5122165000	Connector Socket, 3P		
4 - 17	*5122170000	Connector Socket, 8P		
4 - 18	*5122169000	Connector Socket, 7P		
4 - 19	*5122222000	Connector Socket, 3P (BLK)		
4 - 20	*5127173000	Connector Socket, 11P		
4 - 21	5800512200	Button, D		
4 - 22	*5534685000	Rod, Switch	X-10R	
4 - 23	*5545024001	Shaft, Timer Solenoid	X-10R	
4 - 24	*5555671100	Bracket, Timer Switch	X-10R	
4 - 25	*5168926100	PCB Assy, Timer		
4 - 26	5163045000	Solenoid, Timer		
4 - 27	*5122281000	Connector Socket, 3P (RED)		
4 - 28	*5122164000	Connector Socket, 2P		
4 - 29	*5800525400	Bracket, LAMP POWER PCB		
4 - 30	*5200131601	PCB Assy, LAMP SUPPLY		
4 - 31	*5122280000	Connector Socket, 2P (RED)		

Parts marked with *require longer delivery time.

[U] : U.S.A. [C] : CANADA [GE] : GENERAL EXPORT
 [A] : AUSTRALIA [E] : EUROPE [UK] : U.K.

EXPLODED VIEW-5

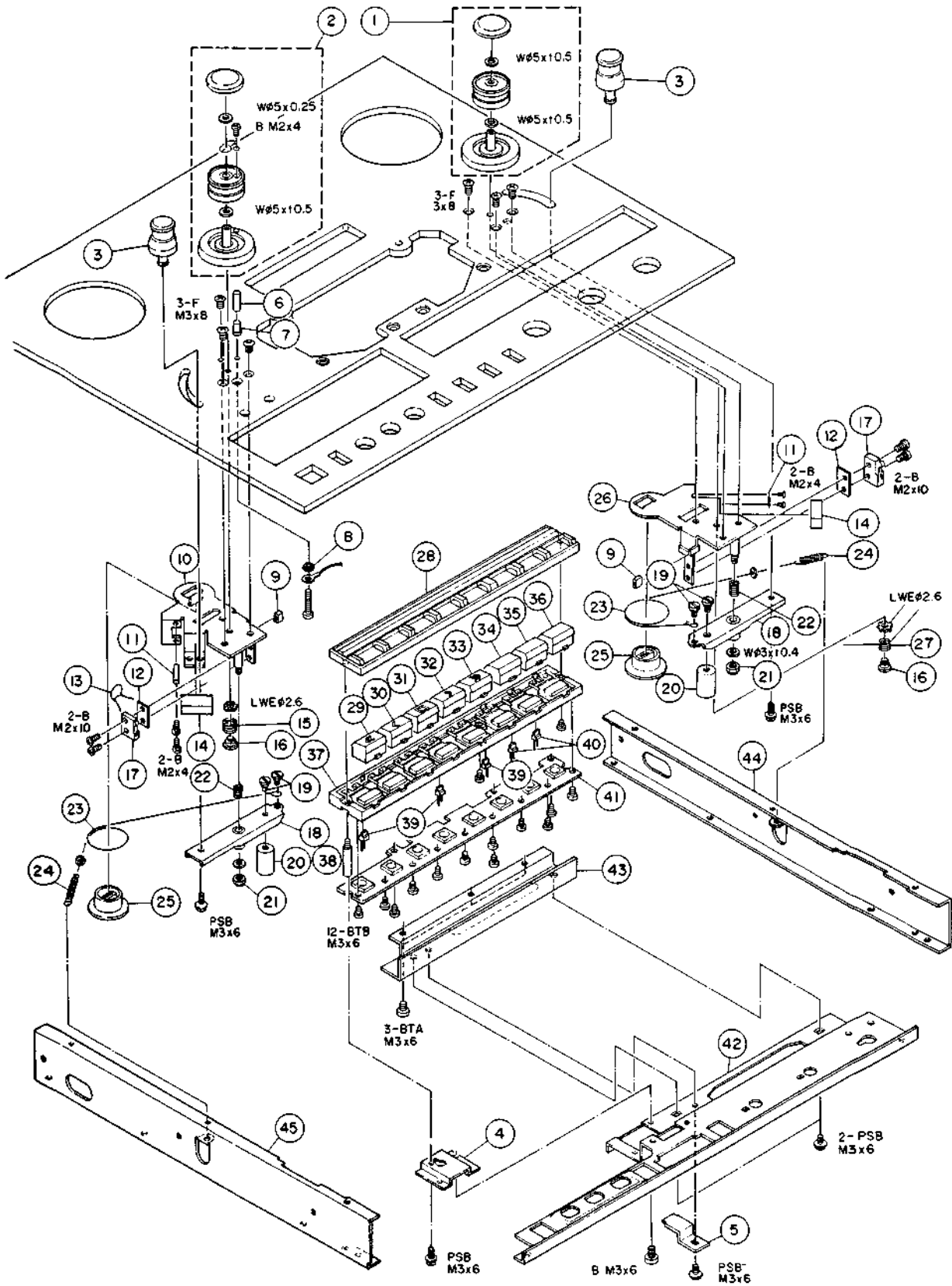

REF. NO.	PARTS NO.	DESCRIPTION	COMMON MODELS	REMARKS
5 - 1	5504741004	Roller Assy, B	X-10R	
5 - 2	5800314203	Roller Assy, A	X-1000R	
5 - 3	5800532200	Roller Assy, Tension		
5 - 4	*5555719100	Bracket, Variable Resistor	X-7	
5 - 5	*5555720000	Bracket, Stopper	X-7R	
5 - 6	*5545042000	Post, Sensing	X-10R	
5 - 7	*5534716000	Post, Insulating	X-10R	
5 - 8	*5534368100	Washer, Insulating	A-6600	
5 - 9	5027699000	Coller, Rubber		
5 - 10	*5504719102	Base Assy, Shut Off; L	X-10R	
5 - 11	*5524215000	Wire, String Stopper	X-10R	
5 - 12	*5550025100	Plate, Insulating	A-450	
5 - 13	5054230000	Capacitor, Ceramic 0.047 μ F 50V \pm 20%		
5 - 14	*5534686001	Cushion	X-10R	
5 - 15	5524229001	Spring, Tension Arm; L	X-10R	
5 - 16	*5581064000	Screw, Shoulder; E		
5 - 17	5301455500	Switch, Micro		
5 - 18	*5800305800	Arm Assy, Tension	X-20R "EE"	
5 - 19	*5800002600	Screw, Shoulder; F	X-10R	
5 - 20	*5545010000	Weight, Counter	X-10R	
5 - 21	*5581045000	Nut, Nylon; M3		
5 - 22	5524069000	Spring, Roller Arm	AL-700	
5 - 23	*5504721000	String Assy, Damper	X-10R	
5 - 24	5524183000	Spring, Motor Switch Lever	A-601R	
5 - 25	*5534684001	Drum, Damper	X-10R	
5 - 26	*5504720101	Base Assy, Shut Off; R	X-10R	
5 - 27	5524230001	Spring, Tension Arm; R	X-10R	
5 - 28	*5800512800	Escutcheon, Button; Operation		
5 - 29	5800513400	Button, N		
5 - 30	5800513200	Button, L		
5 - 31	5800513500	Button, P		
5 - 32	5800513100	Button, K		
5 - 33	5800513300	Button, M		
5 - 34	5533198000	Button, F	X-10R	
5 - 35	5800513600	Button, Q		
5 - 36	5533199000	Button, G	X-10R	
5 - 37	*5503204001	Base Assy, Button	X-10R	
5 - 38	*5545166001	Stay, Button Escutcheon	X-7R	
5 - 39	5143139000	LED, SLB-26GG (GRN)		
5 - 40	5143140000	LED, SLB-26UR (RED)		
5 - 41	*5168929000	PCB Assy, OPERATION		
5 - 42	*5552403103	Chassis, Ampl.; B	X-7	
5 - 43	*5553321000	Angle, Button Base; B P10	X-7R	
5 - 44	*5552404001	Angle, Side; R	X-7R	
5 - 45	*5552405001	Angle, Side; L	X-7R	

Parts marked with *require longer delivery time.

[U] : U.S.A.

[A] : AUSTRALIA

[C] : CANADA

[E] : EUROPE

[GE] : GENERAL EXPORT

[UK] : U.K.

EXPLODED VIEW-6

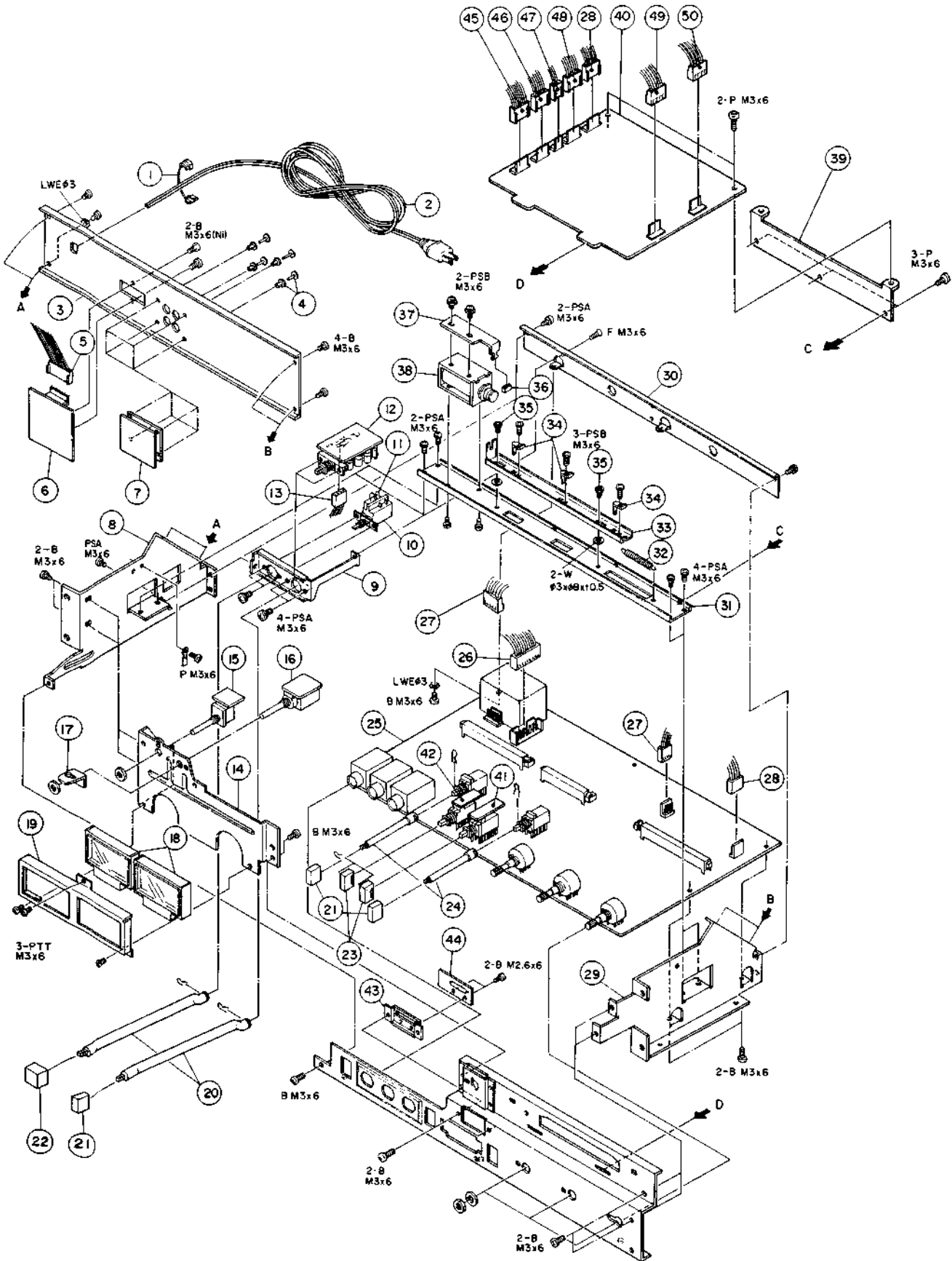

REF. NO.	PARTS NO.	DESCRIPTION	COMMON MODELS	REMARKS
6 - 1	△*5534660000	Strain Relief, AC Power Cord [All except C, UK]		
	△*5317001700	Strain Relief, AC Power Cord [C, UK]		
6 - 2	△*5128010700	Cord, AC Power [C]		
	△*5128075000	Cord, AC Power [U, GE]		
	△*5128018000	Cord, AC Power [E]		
	△*5128031000	Cord, AC Power [A]		
	△*5128047000	Cord, AC Power [UK]		
6 - 3	*5552402000	Panel, Ampl.; Rear	X-7	
6 - 4	*5534118000	Push Rivet		
6 - 5	*5122177000	Connector Socket, 15P		
6 - 6	*5158002000	PCB Assy, CONNECTOR; B	X-10	
6 - 7	*5200036000	PCB Assy, IN/OUTPUT	X-20R	
6 - 8	*5553304000	Frame, Ampl.; L	X-7	
6 - 9	*5555718000	Bracket, Switch	X-7R	
6 - 10	△ 5134036000	Push Switch, POWER [GE]		
	△ 5134018000	Push Switch, POWER [U, C]		
	△ 5134011000	Push Switch, POWER [E, UK, A]		
6 - 11	△*5052910000	Spark Killer, 0.033μF + 120V/125V [U]		
	△*5052907000	Spark Killer, 0.01μF + 300V/300V [GE]		
	△*5052911000	Spark Killer, 0.033μF + 120V/250V [C]		
	△*5267702500	Spark Killer, 0.0047μF 250V [E, UK, A]		
6 - 12	*5158001000	PCB Assy, SPEED	X-7	
6 - 13	*5127168000	Connector Socket, 6P		
6 - 14	*5553307100	Bracket, Meter; B	X-7	
6 - 15	*5168928000	PCB Assy, Switch		
6 - 16	*5168938000	PCB Assy, PITCH CONT		
6 - 17	*5800003000	Bracket, Variable Resistor	X-7	
6 - 18	5296004900	VU Meter	X-1000R	
6 - 19	*5800512900	Plate, Meter		
6 - 20	*5534723000	Rod; A	X-7	
6 - 21	5800512100	Button, C		
6 - 22	5800268600	Button, Power Switch	X-1000R	
6 - 23	5800512000	Button, Loose; B		
6 - 24	*5534712000	Rod; B	X-10R	
6 - 25	*5200129500	PCB Assy, REC/PLAY AMPL.		
6 - 26	*5122170000	Connector Socket, 8P		
6 - 27	*5122160000	Connector Socket, 4P		
6 - 28	*5122282000	Connector Socket, 4P (RED)		
6 - 29	*5553305000	Frame, Ampl.; R	X-7	
6 - 30	*5553297100	Frame, Connector	X-10R	
6 - 31	*5553298001	Bracket, Solenoid	X-10R	
6 - 32	5524222000	Spring, Return	X-10R	
6 - 33	*5555694000	Plate, Slide	X-10R	
6 - 34	*5524224000	Spring, Plate; Chagne	X-10R	
6 - 35	5581056000	Screw, Shoulder; A	A304	
6 - 36	*5534116000	Cushion	A-400	
6 - 37	*5555701000	Plate, Solenoid Stopper	X-10R	
6 - 38	5163043000	Solenoid, Reverse		
6 - 39	*5800512700	Bracket, DBX PCB		
6 - 40	*5200129701	PCB Assy, DBX		
6 - 41	*5200129301	PCB Assy, SWITCH, A		
6 - 42	*5200129401	PCB Assy, SWITCH, B		
6 - 43	*5200129601	PCB Assy, LAMP		
6 - 44	*5800512600	Holder, Lamp		
6 - 45	*5122167000	Connector Socket, 5P (WHT)		
6 - 46	*5122283000	Connector Socket, 5P (RED)		
6 - 47	*5122164000	Connector Socket, 2P (WHT)		
6 - 48	*5122166000	Connector Socket, 4P (WHT)		
6 - 49	*5336109400	Connector Socket, 4P (YEL)		
6 - 50	*5122223000	Connector Socket, 4P (BLK)		

Parts marked with *require longer delivery time.

[U] : U.S.A.

[A] : AUSTRALIA

[C] : CANADA

[E] : EUROPE

[GE] : GENERAL EXPORT

[UK] : U.K.

5 PC BOARDS AND PARTS LIST

PC Board shown view from foil side.

REC/PLAY AMPL. PCB ASSY

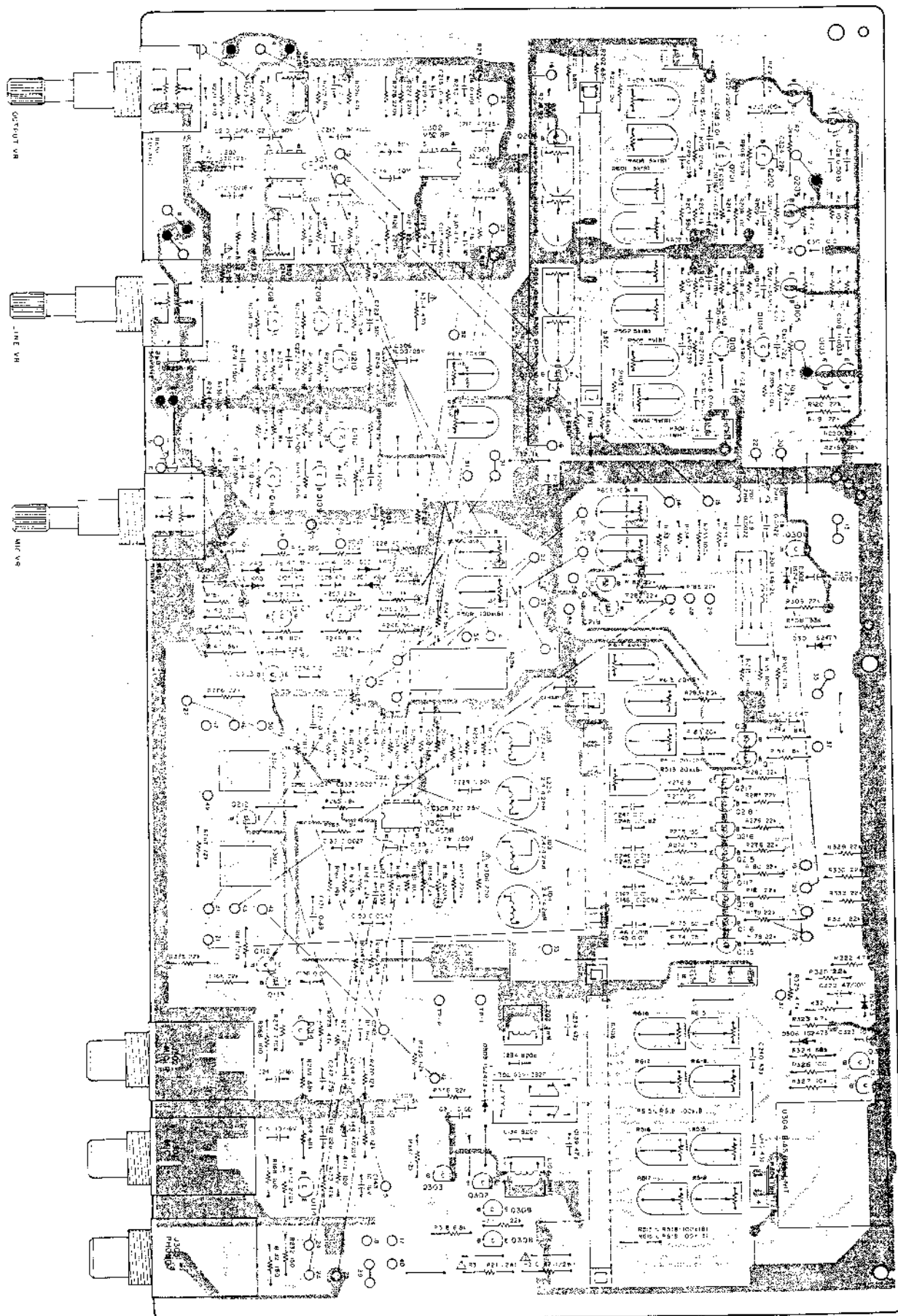

CONTROL PCB ASSY

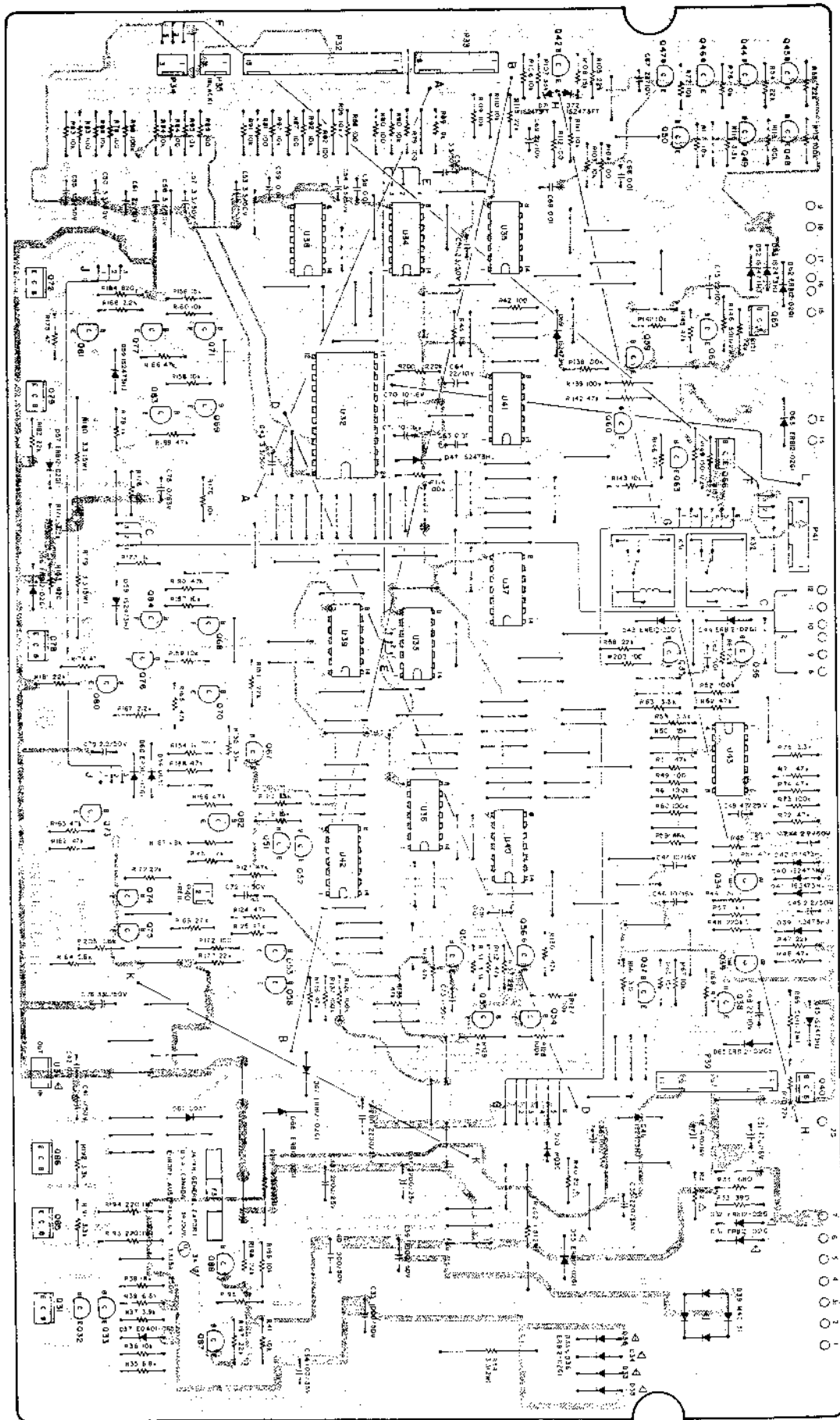

DBX PCB ASSY

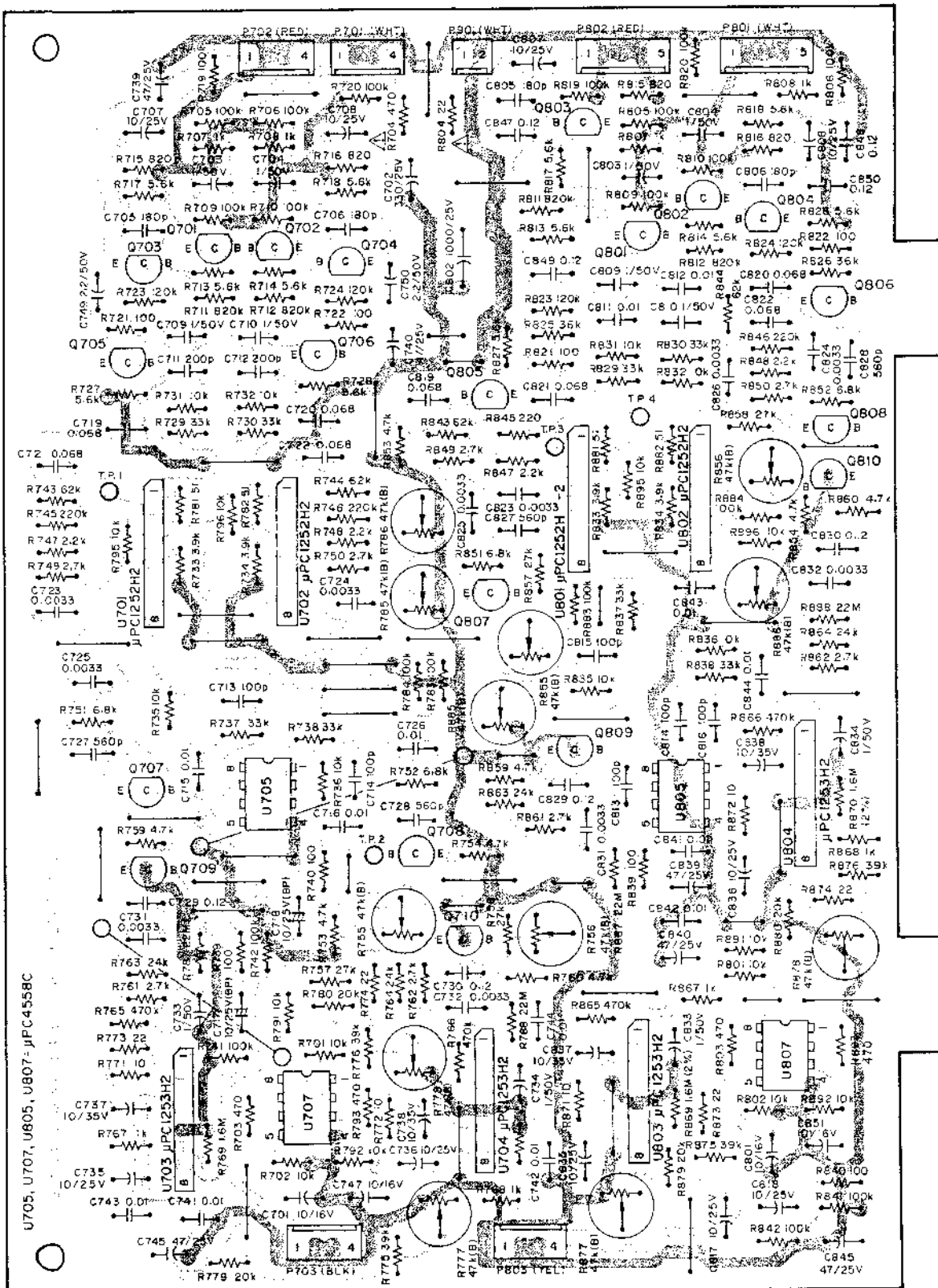

CONNECTOR PCB ASSY

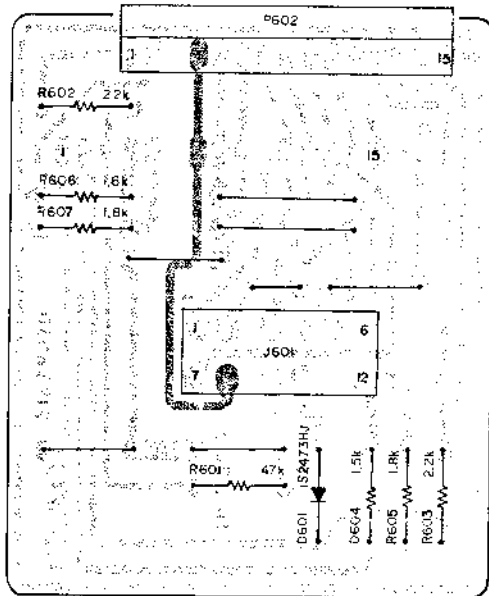

SPEED SW PCB ASSY

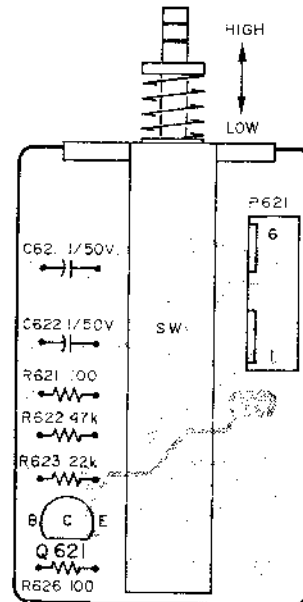

NOTES

1. PC Boards shown viewed from foil side.
2. The colors used on the PCB illustrations have the following significance:
 - : +B power supply circuit
 - : GND
 - : Other
3. Resistor values are in ohms (k = 1,000 ohms).
4. All capacitor values are in microfarads (p = picofarads).

REC/PLAY AMPL. PCB ASSY

REF. NO.	PARTS NO.	DESCRIPTION
	5200129500	PCB Assy
	5210129500	PCB
	IC's	
U301	5220411600	TL4558P
U302	5220418800	M5218P
U303	5220411600	TL4558P
	TRANSISTORS	
Q101, Q201	5230778320	2SC2320F
Q102, Q202	5145036000	2SC945LK
Q103, Q203	5145036000	2SC945LK
Q104, Q204	5145036000	2SC945LK
Q105, Q205	5145036000	2SC945LK
Q106, Q206	5145036000	2SC945LK
Q107, Q207	5145036000	2SC945LK
Q108, Q208	5230778320	2SC2320F
Q109, Q209	5230778320	2SC2320F
Q110, Q210	5145036000	2SC945LK
Q111, Q211	5145036000	2SC945LK
Q112, Q212	5145036000	2SC945LK
Q113, Q213	5145036000	2SC945LK
Q114, Q214	5230778320	2SC2320F
Q115, Q215	5145036000	2SC945LK
Q116, Q216	5145036000	2SC945LK
Q117, Q217	5145036000	2SC945LK
Q118, Q218	5145036000	2SC945LK
Q119, Q219	5145036000	2SC945LK
Q301~Q303	5145036000	2SC945LK
Q306	5145036000	2SC945LK
Q307	5145185000	2SD655E
Q308	5145150000	2SA1015GR
	DIOEDS	
D101, D201	5224015400	1K60
D102, D202	5224015400	1K60
D301~D303	5042517000	1S2473VE
D305, D306	5042517000	1S2473VE
	CARBON RESISTORS	
All resistors are rated $\pm 5\%$ tolerance and $\frac{1}{4}W$.		
R101, R201	5181550000	680k Ω
R102, R202	5181550000	680k Ω
R103, R203	5181458000	100 Ω
R104, R204	5181458000	100 Ω
R105, R205	5181530000	100k Ω
R106, R206	5181544000	390k Ω
R107, R207	5181472000	390 Ω
R108, R208	5181458000	100 Ω
R109, R209	5181482000	1k Ω
R110, R210	5181542000	330k Ω
R111, R211	5181506000	10k Ω
R112, R212	5181490000	2.2k Ω
R113, R213	5181498000	4.7k Ω
R114, R214	5181482000	1k Ω
R115, R215	5181506000	10k Ω
R116, R216	5181496000	3.9k Ω
R117, R217	5181498000	4.7k Ω
R118, R218	5181514000	22k Ω
R119, R219	5181514000	22k Ω
R120, R220	5181514000	22k Ω
R121, R221	5181474000	470 Ω
R122, R222	5181540000	270k Ω
R123, R223	5181540000	270k Ω
R124, R224	5181488000	1.8k Ω
R125, R225	5181506000	10k Ω

REF. NO.	PARTS NO.	DESCRIPTION
R126, R226	5181522000	47k Ω
R127, R227	5181538000	220k Ω
R128, R228	5181538000	220k Ω
R129, R229	5181498000	4.7k Ω
R130, R230	5181498000	4.7k Ω
R131, R231	5181506000	10k Ω
R132, R232	5181462000	150 Ω
R133, R233	5181530000	100k Ω
R134, R234	5181482000	1k Ω
R135, R235	5181530000	100k Ω
R136, R236	5181458000	100 Ω
R137, R237	5181524000	56k Ω
R138, R238	5181544000	390k Ω
R139, R239	5181488000	1.8k Ω
R140, R240	5181500000	5.6k Ω
R141, R241	5181484000	1.2k Ω
R142, R242	5181520000	39k Ω
R143, R243	5181544000	390k Ω
R144, R244	5181458000	100 Ω
R145, R245	5181498000	4.7k Ω
R147, R247	5181524000	56k Ω
R148, R248	5181524000	56k Ω
R149, R249	5181536000	180k Ω
R150, R250	5181446000	33 Ω
R151, R251	5181482000	1k Ω
R152, R252	5181490000	2.2k Ω
R153, R253	5181466000	220 Ω
R154, R254	5181488000	1.8k Ω
R155, R255	5181482000	1k Ω
R156, R256	5181538000	220k Ω
R157, R257	5181538000	220k Ω
R158, R258	5181484000	1.2k Ω
R159, R259	5181530000	100k Ω
R160, R260	5181458000	100 Ω
R161, R261	5181512000	18k Ω
R162, R262	5181510000	15k Ω
R163, R263	5181490000	2.2k Ω
R164, R264	5181490000	2.2k Ω
R165, R265	5181488000	1.8k Ω
R166, R266	5181514000	22k Ω
R167, R267	5181514000	22k Ω
R168, R268	5181458000	100 Ω
R169, R269	5181526000	68k Ω
R170, R270	5181508000	12k Ω
R171, R271	5181460000	120 Ω
R172, R272	5181540000	270k Ω
R173, R273	5181522000	47k Ω
R174, R274	5181462000	150 Ω
R175, R275	5181462000	150 Ω
R176, R276	5181457000	91 Ω
R177, R277	5181457000	91 Ω
R178, R278	5181514000	22k Ω
R179, R279	5181514000	22k Ω
R180, R280	5181514000	22k Ω
R181, R281	5181514000	22k Ω
R182, R282	5181514000	22k Ω
R183, R283	5181513000	20k Ω
R184, R284	5181500000	5.6k Ω
R185, R285	5181514000	22k Ω
R301	△ 5184229000	15 Ω Nonflammable
R302	△ 5184243000	56 Ω Nonflammable
R303	5181490000	2.2k Ω
R304	△ 5184265000	470 Ω Nonflammable
R305	5181484000	1.2k Ω
R306	△ 5184257000	220 Ω Nonflammable

REF. NO.	PARTS NO.	DESCRIPTION		
R307	5181484000	1.2k Ω		
R308	5181518000	33k Ω		
R309	5181514000	22k Ω		
R310	Δ 5185680000	47 Ω	Nonflammable	
R311	Δ 5185686000	82 Ω	Nonflammable	
		Ω		
R316	5181514000	22k Ω		
R318	5181502000	6.8k Ω		
R320	5181490000	2.2k Ω		
R321	5181482000	1k Ω		
R322, R323	5181498000	4.7k Ω		
R324	5181526000	68k Ω		
R325	5181498000	4.7k Ω		
R326	5181458000	100 Ω		
R327	5181506000	10k Ω		
R328~R330	5181514000	22k Ω		
R331	5181482000	1k Ω		
R332, R333	5181514000	22k Ω		
R335~R337	5181514000	22k Ω		
CAPACITORS				
C101, C201	5171590000	Elec.	10 μ F	16V
C102, C202	5173055000	Elec.	220 μ F	25V
C103, C203	5173011000	Elec.	10 μ F	25V
C104, C204	5172304000	Ceramic	22pF	50V
C105, C205	5260165052	Elec.	47 μ F	10V
C106, C206	5263166723	Metalized	0.01 μ F	50V
C107, C207	5260226110	Elec.	1 μ F	50V
C108, C208	5263166123	Metalized	3300pF	50V
C109, C209	5263166823	Metalized	0.012 μ F	50V
C110, C210	5172992000	Elec.	1 μ F	50V
C111, C211	5173010000	Elec.	10 μ F	16V
C112, C212	5172312000	Ceramic	100pF	50V
C113, C213	5260221150	Elec.	1 μ F	50V (LL)
C114, C214	5172992000	Elec.	1 μ F	50V
C115, C215	5173010000	Elec.	10 μ F	16V
C116, C216	5263165523	Metalized	1000pF	50V
C117, C217	5173037000	Elec.	47 μ F	25V
C118, C218	5263165923	Metalized	2200pF	50V
C119, C219	5172992000	Elec.	1 μ F	50V
C121, C221	5172300000	Ceramic	10 μ F	50V
C121, C222	5172992000	Elec.	1 μ F	50V
C123, C223	5172992000	Elec.	1 μ F	50V
C124, C224	5173001000	Elec.	10 μ F	16V
C125, C225	5172308000	Ceramic	47pF	50V
C126, C226	5260162050	Elec.	4.7 μ F	35V
C127, C227	5173052000	Elec.	220 μ F	6.3V
C128, C228	5260165052	Elec.	47 μ F	10V
C129, C229	5172992000	Elec.	1 μ F	50V
C130, C230	5173010000	Elec.	10 μ F	16V
C131, C231	5263168623	Metalized	0.39 μ F	50V
C132, C232	5260222050	Elec.	10 μ F	35V
C133, C233	5263166023	Metalized	2700pF	50V
C134, C234	5172826000	Polysty.	820pF	50V
C136, C236	5054877500	Mylar	0.01 μ F	100V
C139, C239	5172796000	Polysty.	47pF	50V
C140, C240	5172795000	Polysty.	43pF	50V
C141, C241	5173010000	Elec.	10 μ F	16V
C142, C242	5172304000	Ceramic	22pF	50V
C143, C243	5173010000	Elec.	10 μ F	16V
C144, C244	5260165052	Elec.	47 μ F	10V
C145, C245	5263166623	Metalized	8200pF	50V
C146, C246	5263166723	Metalized	0.01 μ F	50V
C147, C247	5263166623	Metalized	8200pF	50V
C148, C248	5263166623	Metalized	8200pF	50V
C149, C249	5263167423	Metalized	0.039 μ F	50V

REF. NO.	PARTS NO.	DESCRIPTION		
C150, C250	5263166323	Metalized	4700pF	50V
C301	5054877500	Mylar	0.01 μ F	100V
C302~C304	5173064000	Elec.	330 μ F	25V
C305	5173070000	Elec.	470 μ F	6.3V
C306	5173082000	Elec.	1000 μ F	25V
C307	5263167523	Metalized	0.047 μ F	50V
C308	5173055000	Elec.	220 μ F	25V
C309	5173046000	Elec.	100 μ F	25V
C310	5263165523	Metalized	1000pF	50V
C322	5260165052	Elec.	47 μ F	10V
C323	5260162552	Elec.	10 μ F	16V
C324, C325	5260162652	Elec.	10 μ F	25V
VARIABLE RESISTORS				
R501, R601	5280002802	Semi-fixed	1k Ω (B)	
R502, R602	5280002802	Semi-fixed	1k Ω (B)	
R503, R603	5280003502	Semi-fixed	10k Ω (B)	
R504, R604	5280003602	Semi-fixed	10k Ω (B)	
R505, R605	5280003302	Semi-fixed	5k Ω (B)	
R506, R606	5280003302	Semi-fixed	5k Ω (B)	
R507, R607	5280003502	Semi-fixed	10k Ω (B)	
R508, R608	5280004202	Semi-fixed	100k Ω (B)	
R509, R609	5280004202	Semi-fixed	100k Ω (B)	
R510, R610	5282705102		50k Ω (A) x 2	
R511, R611	5280006002		50k Ω (A) x 2	
R512, R612	5282706002		50k Ω (A) x 2	
R513, R613	5280003602	Semi-fixed	20k Ω (B)	
R514, R614	5280003602	Semi-fixed	20k Ω (B)	
R515, R615	5280004202	Semi-fixed	100k Ω (B)	
R516, R616	5280004202	Semi-fixed	100k Ω (B)	
R517, R617	5280004202	Semi-fixed	100k Ω (B)	
R518, R618	5280004202	Semi-fixed	100k Ω (B)	
R519, R619	5280003602	Semi-fixed	20k Ω (B)	
COILS				
L101, L201	5160107000	Choke	1200 μ H	5%
L102, L202	5056659000	Trap	3mH	20%
L103, L203	5056637000	Record EQ	2.4 - 4.2mH	20%
L104, L204	5056637000	Record EQ	2.4 - 4.2mH	20%
SWITCHES				
S301	5134095000	Push, 4-2		
S304	5134095000	Push, 4-2		
S305	5131044000	Slide, 9-2		
S306	5131045000	Slide, 6-2		
S307	5131044000	Slide, 9-2		
CONNECTOR PLUGS				
P301	5122128000	4P		
P302	5122301000	4P (RED)		
P303	5122132000	8P		
MISCELLANEOUS				
K301	5061137000	Relay, Reed; LAB2L, 12V		
K302	5290009400	Relay; G2V-282P, 24V		
J301, J302	5124045000	Jack, MIC		
J303	5124046000	Jack, PHONES		
U304	5040090000	BIAS OSC Unit		

CONTROL PCB ASSY

REF. NO.	PARTS NO.	DESCRIPTION
	5200004603	PCB Assy [C]
	5200004614	PCB Assy [E, UK, A]
	5200004624	PCB Assy [GE]†
	5200004630	PCB Assy [U]
	5167932102	PCB [U, C]
	5210109700	PCB [All except U, C]
IC's		
U31	△5147058000	NJM78M05A
U32	5147054000	AN6251
U33~U37	5147056000	HD7400P
U38~U42	5147057000	HD7402P
U43	5147039000	NJM2901N
TRANSISTORS		
Q31	△5145087000	2SD313E
Q32	5042625000	2SC1318S
Q33	5230776520	2SC1685R
Q34, Q35	5042383000	2SC536F
Q36, Q37	5230776520	2SC1685R
Q38	5230015220	2SA1127R
Q39	5042383000	2SC536F
Q40	5042564000	2SC1061C
Q42	5230776520	2SC1685R
Q44~Q50	5230776520	2SC1685R
Q51, Q52	5042383000	2SC536F
Q53	5230015220	2SA1127R
Q54~Q56	5230776520	2SC1685R
Q57	5042383000	2SC536F
Q58	5230015220	2SA1127R
Q59	5042383000	2SC536F
Q60	5042553000	2SA733P
Q62, Q63	5230015220	2SA1127R
Q65, Q66	5042553000	2SA733P [GE]
	5042564000	2SC1061C [All except GE]
Q67~Q71	5230776520	2SC1685R
Q72	5145087000	2SD313E
Q73	5042625000	2SC1318S
Q74, Q75	5230776520	2SC1685S
Q76	5042553000	2SA733P
Q77	5230015220	2SA1127R
Q78, Q79	5145087000	2SD313E
Q80, Q81	5042625000	2SC1318S
Q82~Q84	5230015220	2SA1127R
Q85, Q86	5145129000	2SB507E
Q87, Q88	5042625000	2SC1318S
DIODES		
D31~D36	△5143243000	ERB12-02G1
D37	5143154000	Zener, EQA01-06S
D38	△5143142000	MAC-51
D39~D42	5143118000	1S2473HJ
D43, D44	5143243000	ERB12-02G1
D45~D47	5143118000	1S2473HJ
D52, D53	5143118000	1S2473HJ
D54	5143017000	U05C
D55~D57	△5143243000	ERB12-02G1
D58, D59	5143118000	1S2473HJ
D60	5143243000	ERB12-02G1
D61	5143017000	U05C
D62, D63	5143243000	ERB12-02G1
D65~D67	5143243000	ERB12-02G1
D69	5143118000	1S2473HJ
D70	5143089000	W03C
D71, D72	5224012920	1S2473FT

REF. NO.	PARTS NO.	DESCRIPTION
RESISTORS		
All resistors are rated ±5% tolerance and ¼W and are carbon type unless otherwise noted.		
R31	△5184209000	2.2Ω Nonflammable
R32	5183072000	390Ω
R33	5183078000	680Ω
R34	5184306000	3.3Ω 2W 10% Cement
R35	5183102000	6.8kΩ
R36	5183106000	10kΩ
R37	5183096000	3.9kΩ
R38	5183112000	18kΩ
R39	5183102000	6.8kΩ
R40	△5184233000	22Ω Nonflammable
R41	5183106000	10kΩ
R42	5183058000	100Ω
R43	5183106000	10kΩ
R44	5183086000	1.5kΩ
R45	5183086000	1.5kΩ
R46	5183122000	4.7kΩ
R47	5183114000	22kΩ
R48	5183138000	220kΩ
R49	5183058000	100Ω
R50	5183110000	15kΩ
R51	5183122000	47kΩ
R52	5183130000	100kΩ
R53	5183094000	3.3kΩ
R54, R55	5183114000	22kΩ
R56	5183122000	47kΩ
R57	5183082000	1kΩ
R58	5183114000	22kΩ
R59	5183126000	68kΩ
R60, R61	5183130000	100kΩ
R62	5183122000	47kΩ
R63	5183094000	3.3kΩ
R64	5183114000	22kΩ
R65	5183110000	15kΩ
R66	5183118000	33kΩ
R67	5183106000	10kΩ
R68	5183122000	47kΩ
R69	5180062000	150Ω
R70	5183114000	22kΩ
R71, R72	5183122000	47kΩ
R73	5183130000	100kΩ
R74	5183122000	47kΩ
R75	5183094000	3.3kΩ
R76, R77	5183106000	10kΩ
R78~R87	5183058000	100Ω
R88~R97	5183106000	10kΩ
R98	5183130000	100kΩ
R103	5183106000	10kΩ
R104	5183058000	100Ω
R105	5183114000	22kΩ
R106	5183106000	10kΩ
R107	5183118000	33kΩ
R108	5183110000	15kΩ
R109~R111	5183106000	10kΩ
R112	5183058000	100Ω
R113	5183114000	22kΩ
R114, R115	5183130000	100kΩ
R116	5183094000	3.3kΩ
R117	5183106000	10kΩ
R118	5183114000	22kΩ
R119	5183110000	15kΩ

REF. NO.	PARTS NO.	DESCRIPTION			
R120	5183118000	33kΩ			
R122	5183114000	22kΩ			
R123~R125	5183122000	47kΩ			
R126~R128	5183130000	100kΩ			
R129, R130	5183122000	47kΩ			
R131	5183094000	3.3kΩ			
R132	5183122000	47kΩ			
R133	5183114000	22kΩ			
R134~R136	5183122000	47kΩ			
R137~R139	5183130000	100kΩ			
R140	5183122000	47kΩ			
R142, R143	5183106000	10kΩ			
R145, R146	5183122000	47kΩ			
R148, R149	5183062000	150Ω			
R151, R152	5183114000	22kΩ			
R153	5183114000	22kΩ			
R154	5183082000	1kΩ			
R155	5183118000	33kΩ			
R156	5183110000	15kΩ			
R157~R160	5183106000	10kΩ			
R162, R163	5183122000	47kΩ			
R164	5183100000	5.6kΩ			
R165, R166	5183122000	47kΩ			
R167, R168	5183090000	2.2kΩ			
R169	5183116000	27kΩ			
R170	5181508000	12kΩ			
R171	5183094000	3.3kΩ			
R172	5183058000	100Ω			
R173	5183082000	1kΩ			
R174, R175	5183050000	47Ω			
R176	5183080000	820Ω			
R177	5183114000	22kΩ			
R178	5183082000	1kΩ			
R179, R180	5184410000	3.3Ω	5W	10%	Cement
R181, R182	5183114000	22kΩ			
R183, R184	5183080000	820Ω			
R185	5183084000	1.2kΩ			
R186	5183122000	47kΩ			
R187	5183088000	1.8kΩ			
R188~R190	5183122000	47kΩ			
R191, R192	5183094000	3.3kΩ			
R193, R194	5184763000	220Ω	1W		Nonflammable
R195, R196	5183106000	10kΩ			
R197, R198	5183114000	22kΩ			
R199	5184306000	3.3Ω	2W	10%	Cement
R200	5183138000	220kΩ			
R202	5184302000	1.5Ω	2W	10%	Cement
R203	5183058000	100Ω			
R205	5183088000	1.8kΩ			
CAPACITORS					
C31, C32	5172961000	Elec.	470μF	16V	
C33	5172973000	Elec.	1000μF	50V	
C34	5172936000	Elec.	100μF	35V	
C35	5172945000	Elec.	220μF	35V	
C36	5172936000	Elec.	100μF	35V	
C37, C38	5055714800	Elec.	2200μF	25V	
C39, C40	5172973000	Elec.	1000μF	50V	
C41	5172882000	Elec.	1μF	50V	
C42	5054204000	Ceramic	0.01μF	50V	10%
C43	5172890000	Elec.	3.3μF	50V	

REF. NO.	PARTS NO.	DESCRIPTION			
C44, C45	5172886000	Elec.	2.2μF	50V	
C46, C47	5172900000	Elec.	10μF	16V	
C48	5172907000	Elec.	22μF	10V	
C49	5172894000	Elec.	4.7μF	25V	
C50~C57	5172890000	Elec.	3.3μF	50V	
C58, C59	5054204000	Elec.	0.01μF	50V	
C61	5172907000	Elec.	22μF	10V	
C63	5054204000	Ceramic	0.01μF	50V	10%
C64	5172907000	Elec.	22μF	10V	
C66	5054204000	Ceramic	0.01μF	50V	10%
C67	5172907000	Elec.	22μF	10V	
C68	5054204000	Ceramic	0.01μF	50V	10%
C69	5172907000	Elec.	22μF	10V	
C70	5172894000	Elec.	4.7μF	25V	
C71	5172900000	Elec.	10μF	16V	
C72, C73	5172882000	Elec.	1μF	50V	
C75	5172907000	Elec.	22μF	10V	
C76	5172955000	Elec.	330μF	50V	
C78	5172904000	Elec.	10μF	63V	
C79	5172886000	Elec.	2.2μF	50V	
C80	5055714800	Elec.	2200μF	25V	
C81, C82	5054204000	Ceramic	0.01μF	50V	10%
MISCELLANEOUS					
K31, K32	5290008500	Relay; G2U-112P	24V		
	5033291000	Plate, Insulating			
	5033295000	Tube, Insulating			
	5122127000	Connector Plug 3P	P34		
	5122131000	Connector Plug 7P	P41		
	5122132000	Connector Plug 8P	P33		
	5122135000	Connector Plug 11P	P39		
	5122139000	Connector Plug 15P	P12		
	5122184000	Connector Plug 3P (BLK)	P35		
	5142087000	Fuse Holder			
F31	△5307027100	Mini Fuse 3A	125V [U, C, GE]		
	△5142191000	Mini Fuse 3.15A	250V [E, U, K, A]		

SPEED SW PCB ASSY

REF. NO.	PARTS NO.	DESCRIPTION			
	5158001000	PCB Assy			
	5157001001	PCB			
TRANSISTOR					
Q621	5042383000	2SC536(F)			
CARBON RESISTORS					
All resistors are rated ±5% tolerance and 1/4W.					
R621	5057058000	100Ω			
R622	5057122000	47kΩ			
R623	5057114000	22kΩ			
R626	5057058000	100Ω			
CAPACITORS					
C621, C622	5055454000	Elec.	1μF	50V	
MISCELLANEOUS					
P621	5122130000	Connecotr, Plug 6P			
	5134093000	Switch, Push 6-2			

CONNECTOR PCB ASSY

REF. NO.	PARTS NO.	DESCRIPTION
	5168931100	PCB Assy
	5167931000	PCB
DIODE		
D601	5143118000	1S2473HJ
CARBON RESISTORS		
All resistors are rated $\pm 5\%$ tolerance and $\frac{1}{4}W$.		
R601	5183122000	47k Ω
R602, R603	5183090000	2.2k Ω
R604	5183086000	1.5k Ω
R605~R607	5183088000	1.8k Ω
MISCELLANEOUS		
P602	5122158000	Connector Plug, 15P
J601	5122336000	Connector Plug, 12P
	5554099100	Bracket, Connector (A-7300)

DBX PCB ASSY

REF. NO.	PARTS NO.	DESCRIPTION
	5200129701	PCB Assy
	5210029701	PCB
IC's		
U701, U801	5220414501	μ PC1252H-2
U702, U802	5220414501	μ PC1252H-2
U703, U803	5220414601	μ PC1253H-2
U704, U804	5220414601	μ PC1253H-2
U705, U805	5220406600	μ PC4558C
U707, U807	5220406600	μ PC4558C
TRANSISTORS		
Q701, Q801	5042522000	2SC945K
Q702, Q802	5042522000	2SC945K
Q703, Q803	5042553000	2SA733P
Q704, Q804	5042553000	2SA733P
Q705, Q805	5042522000	2SC945K
Q706, Q806	5042522000	2SC945K
Q707, Q807	5042522000	2SC945K
Q708, Q808	5042522000	2SC945K
Q709, Q809	5042553000	2SA733P
Q710, Q810	5042553000	2SA733P
RESISTORS		
All resistors are rated $\pm 5\%$ tolerance, $\frac{1}{4}W$ and are carbon type unless otherwise noted.		
R701, R801	5240030620	10k Ω
R702, R802	5240030620	10k Ω
R703, R803	5240027420	470 Ω
R704, R804	5184265000	470 Ω
R705, R805	5240033020	100k Ω
R706, R806	5240033020	100k Ω
R707, R807	5240028220	1k Ω
R708, R808	5240028220	1k Ω
R709, R809	5240033020	100k Ω
R710, R810	5240033020	100k Ω

REF. NO.	PARTS NO.	DESCRIPTION
R711, R811	5240035220	820k Ω
R712, R812	5240035220	820k Ω
R713, R813	5240030020	5.6k Ω
R714, R814	5240030020	5.6k Ω
R715, R815	5240028020	820 Ω
R716, R816	5240028020	820 Ω
R717, R817	5240030020	5.6k Ω
R718, R818	5240030020	5.6k Ω
R719, R819	5240033020	100k Ω
R720, R820	5240033020	100k Ω
R721, R821	5240025820	100 Ω
R722, R822	5240025820	100 Ω
R723, R823	5240033220	120k Ω
R724, R824	5240033220	120k Ω
R825	5240031920	36k Ω
R826	5240031920	36k Ω
R727, R827	5240030020	5.6k Ω
R728, R828	5240030020	5.6k Ω
R729, R829	5240031820	33k Ω
R730, R830	5240031820	33k Ω
R731, R831	5240030620	10k Ω
R732, R832	5240030620	10k Ω
R733, R833	5240029620	3.9k Ω
R734, R834	5240029620	3.9k Ω
R735, R835	5240030620	10k Ω
R736, R836	5240030620	10k Ω
R737, R837	5240031820	33k Ω
R738, R838	5240031820	33k Ω
R739, R839	5240025820	100 Ω
R740, R840	5240025820	100 Ω
R741, R841	5240033020	100k Ω
R724, R842	5240033020	100k Ω
R743, R843	5240032520	62k Ω
R744, R844	5240032520	62k Ω
R745, R845	5240033820	220k Ω
R746, R846	5240033820	220k Ω
R747, R847	5240029020	2.2k Ω
R748, R848	5240029020	2.2k Ω
R749, R849	5240029220	2.7k Ω
R750, R805	5240029220	2.7k Ω
R751, R851	5240030220	6.8k Ω
R752, R852	5240030220	6.8k Ω
R753, R853	5240029820	4.7k Ω
R754, R854	5240029820	4.7k Ω
R757, R857	5240031620	27k Ω
R758, R858	5240031620	27k Ω
R759, R859	5240029820	4.7k Ω
R760, R860	5240029820	4.7k Ω
R761, R861	5240029220	2.7k Ω
R762, R862	5240029220	2.7k Ω
R763, R863	5240031520	10k Ω
R764, R864	5240031520	10k Ω
R765, R865	5240034620	470k Ω
R766, R866	5240034620	470k Ω
R767, R867	5240028220	1k Ω
R768, R868	5240028220	1k Ω
R769, R869	5240075921	1.6M Ω
R770, R870	5240075921	1.6M Ω
R771, R871	5240023420	10 Ω
R772, R872	5240023420	10 Ω
R773, R873	5240024220	22 Ω
R774, R874	5240024220	22 Ω
R775, R875	5240032020	39k Ω
R776, R876	5240032020	39k Ω
R779, R879	5240031320	20k Ω

REF. NO.	PARTS NO.	DESCRIPTION
R780, R880	5240031320	20kΩ
R781, R881	5240025120	51Ω
R782, R882	5240025120	51Ω
R783, R883	5240033020	100kΩ
R784, R884	5240033020	100kΩ
R787, R887	5240319000	22MΩ
R788, R888	5240319000	22MΩ
R791, R891	5240030620	10kΩ
R792, R892	5240030620	10kΩ
R793, R893	5240027420	470Ω
R795, R895	5240030620	10kΩ
R796, R896	5240030620	10kΩ
CAPACITORS		
C701, C801	5260162520	Elec. 10μF 16V
C702, C802	5260187700	Elec. 330μF 25V
C703, C803	5260160720	Elec. 1μF 50V
C704, C804	5260160720	Elec. 1μF 50V
C705, C805	5263106010	Polysty. 180pF 100V
C706, C806	5263106010	Polysty. 180pF 100V
C707, C807	5171591000	Elec. 10μF 25V
C708, C808	5171591000	Elec. 10μF 25V
C709, C809	5260160720	Elec. 1μF 50V
C710, C810	5260160720	Elec. 1μF 50V
C711, C811	5263106110	Polysty. 200pF 100V
C712, C812	5263106110	Polysty. 200pF 100V
C713, C813	5263105410	Polysty. 100pF 100V
C714, C814	5263105410	Polysty. 100pF 100V
C715, C815	5263166723	Metalized 0.01μF 50V
C716, C816	5263166723	Metalized 0.01μF 50V
C717, C817	5260067120	Elec. 10μF 25V
C718, C818	5260067120	Elec. 10μF 25V
C719, C819	5263167723	Metalized 0.068μF 50V
C720, C820	5263167723	Metalized 0.068μF 50V
C721, C821	5268167723	Metalized 0.068μF 50V
C722, C822	5268167723	Metalized 0.068μF 50V
C723, C823	5263166123	Metalized 3300pF 50V
C724, C824	5263166123	Metalized 3300pF 50V
C725, C825	5263166123	Metalized 3300pF 50V
C726, C826	5263166123	Metalized 3300pF 50V
C727, C827	5263107210	Polysty. 560pF 100V
C728, C828	5263107210	Polysty. 560pF 100V
C729, C829	5263168023	Metalized 0.12μF 50V
C730, C830	5263168023	Metalized 0.12μF 50V
C731, C831	5263166123	Metalized 3300pF 50V
C732, C832	5263166123	Metalized 3300pF 50V
C733, C833	5260160720	Elec. 1μF 50V
C734, C834	5260160720	Elec. 1μF 50V
C735, C835	5260162620	Elec. 10μF 25V
C736, C836	5260162620	Elec. 10μF 25V
C737, C837	5260222030	Elec. 10μF 35V
C738, C838	5260222030	Elec. 10μF 35V
C739, C839	5260165220	Elec. 47μF 25V
C740, C840	5260165220	Elec. 47μF 25V
C741, C841	5263166723	Metalized 0.01μF 50V
C742, C842	5263166723	Metalized 0.01μF 50V
C743, C843	5263166723	Metalized 0.01μF 50V
C744, C844	5263166723	Metalized 0.01μF 50V
C745, C845	5260165220	Elec. 47μF 25V
C747	5260162520	Elec. 10μF 16V
C749, C750	5260161120	Elec. 2.2μF 50V
C847, C848	5263168023	Metalized 0.12μF 50V
C849, C850	5263168023	Metalized 0.12μF 50V
C851	5260162520	Elec. 10μF 16V

REF. NO.	PARTS NO.	DESCRIPTION
VARIABLE RESISTORS		
R755, R855	5280072101	Semi-fixed 47kΩ(B)
R756, R856	5280072101	Semi-fixed 47kΩ(B)
R777, R877	5280062101	Semi-fixed 47kΩ(B)
R778, R878	5280062101	Semi-fixed 47kΩ(B)
R785, R885	5280062101	Semi-fixed 47kΩ(B)
R786, R886	5280062101	Semi-fixed 47kΩ(B)
MISCELLANEOUS		
P701	5122128000	Connector Plug, 4P (WHT)
P702	5122301000	Connector Plug, 4P (RED)
P703	5122185000	Connector Plug, 4P (BLK)
P801	5122129000	Connector Plug, 5P (WHT)
P802	5122302000	Connector Plug, 5P (RED)
P803	5122128000	Connector Plug, 4P (WHT)
P901	5122126000	Connector Plug, 2P (WHT)

TIMER PCB ASSY (PC Board Omitted.)		
REF. NO.	PARTS NO.	DESCRIPTION
	5168926100	PCB Assy
	5167926000	PCB
DIODE		
D641	5143243000	ERB12-02G1
MISCELLANEOUS		
P641	5122145000	Connector Plug, 2P (WHT)
P642	5122454000	Connector Plug, 3P (RED)
S32	5134090000	Push Switch 2-4

OPERATION PCB ASSY (PC Board Omitted.)		
REF. NO.	PARTS NO.	DESCRIPTION
	5168929000	PCB Assy
	5167929000	PCB
D801~D803	5143139000	LED, SLB-260GG (GREEN)
D804, D805	5143140000	LED, SLB-26UR (RED)
S801~S808	5138011000	Switch, Tact

SWITCH PCB ASSY (PC Board Omitted)		
REF. NO.	PARTS NO.	DESCRIPTION
	5168928000	PCB Assy
	5167928000	PCB
S34	5133013000	Rotary Switch

SWITCH PAC A ASSY

REF. NO.	PARTS NO.	DESCRIPTION
	5200129301	PCB Assy
	5210129301	PCB
R146, R246	5240033020	Carbon Resistor 100kΩ 5% ¼W
S302	5300035200	Push Switch, 6-2

SWITCH PCB B ASSY

REF. NO.	PARTS NO.	DESCRIPTION
	5200129401	PCB Assy
	5210129401	PCB
S303	5300035300	Push Switch, 4-2

LAMP SUPPLY PCB ASSY

REF. NO.	PARTS NO.	DESCRIPTION
	5200131601	PCB Assy
	5210131601	PCB
R901	5183757000	Fuse Resistor 3.3Ω 10% ¼W
C901	5260190200	Capacitor Elec. 2200μF 10V
D901	5143243000	Diode ERB12-02G1
P901	5122299000	Connector Plug, 2P (RED)

LAMP PCB ASSY

REF. NO.	PARTS NO.	DESCRIPTION
	5200129601	PCB Assy
	5210129601	PCB
DS01	5310006700	Lamp, Fuse; DC6.3V 150MA

PINCH CONT PCB ASSY (PC Board Omitted)

REF. NO.	PARTS NO.	DESCRIPTION
	5168938000	PCB Assy
	5167988000	PCB
S36	5150239000	5kΩ(B)

FUSE PCB ASSY (PC Board Omitted)

REF. NO.	PARTS NO.	DESCRIPTION
	5168997000	FUSE PCB ASSY [U, C]
	5167997000	PCB
F1, F2	△5307004700	Fuse 7A 125V
F3	△5307004100	Fuse 2A 250V
	△5041237000	Fuse Holder
	5158105000	Fuse PCB Assy [E, UK, A]
	5157105000	PCB Assy
F1, F2	△5142193000	Mini Fuse 5A 250V
F3	△5142189000	Mini Fuse 2A 250V
	△5142087000	Fuse Holder

IN/OUTPUT TERMINAL PCB ASSY (PC Board Omitted)

REF. NO.	PARTS NO.	DESCRIPTION
	5200036000	PCB Assy
	5167937101	PCB
	5124058000	Jack, 4P
R535, R536	5183120000	39kΩ ¼W 5%

ASSEMBLING HARDWARE CODING LIST

All screws conform to ISO standards, and have crossrecessed heads, unless otherwise noted. ISO screws have the head inscribed with a point as in the figure to the right.

FOR EXAMPLE:

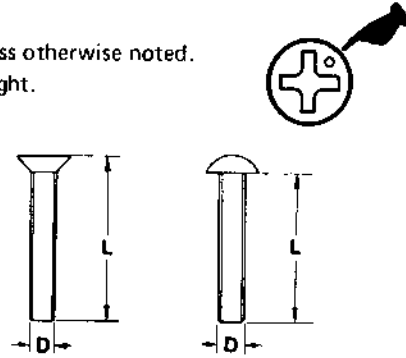
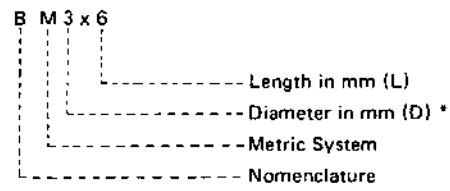

* Inner dia. for washers and nuts

	Code	Name	Type		Code	Name	Type
MACHINE SCREW	R	Round Head Screw		TAPPING SCREW	BT A	Binding Head Tapping Screw(A Type)	
	P	Pan Head Screw			BT B	Binding Head Tapping Screw(B Type)	
	T	Stove Head Screw (Truss)			RT A	Round Head Tapping Screw(A Type)	
	B	Binding Head Screw			RT B	Round Head Tapping Screw(B Type)	
	F	Flat Countersunk Head Screw		SETSCREW	SF	Hex Socket Setscrew(Flat Point)	
	O	Oval Countersunk Head Screw			SC	Hex Socket Setscrew(Cup Point)	
WOOD SCREW	RW	Round Head Wood Screw		SS	Slotted Socket Setscrew(Flat Point)		
TAPTITE SCREW	PTT	Pan Head Taptite Screw		WASHER	E	E-Ring (Retaining Washer)	
	WTT	Washer Head Taptite Screw			W	Flat Washer (Plain)	
SEMS SCREW	BSA	Binding Head SEMS Screw(A Type)			SW	Lock Washer (Spring)	
	BSB	Binding Head SEMS Screw(B Type)			LWI	Lock Washer (Internal Teeth)	
	BSF	Binding Head SEMS Screw(F Type)			LWE	Lock Washer (External Teeth)	
	PSA	Pan Head SEMS Screw(A Type)		TW	Trim Washer (Countersunk)		
	PSB	Pan Head SEMS Screw(B Type)		NUT	N	Hex Nut	

TABLE OF SEMICONDUCTORS

AN6251 (TOP VIEW) 	HD7400P HD7402P (TOP VIEW) 	NJM2901N (TOP VIEW) 	μPC4558C (TOP VIEW) 	M5218P NJM203D TL4558 (TOP VIEW)
μPC1252H2 μPC1253H2 (SIDE VIEW) 	NJM78M05A <p>1: OUT 2: GND 3: IN</p>	2SA733(P) 2SA1015GR 2SA1127R 	2SB507(E) 	2SC536(F)
2SC1061(C) 2SD235(Q) 	2SC828A(R) 2SC945A(K) 2SC945L(K) 2SC1318(S) 2SC1685(R) 2SC2320(F) 2SD655(E) 	2SD313(E) 	M4C-51 (BOTTOM VIEW) 	1S2473HJ 1S2473VE
EQA01-06S 	ERB12-02G1 <p>RED BLACK</p>	1K60 	U05C 	

TEAC SCHEMATIC DIAGRAM (CONTROL) X-700R

1

2

3

4

5

6

7

8

A

B

C

D

E

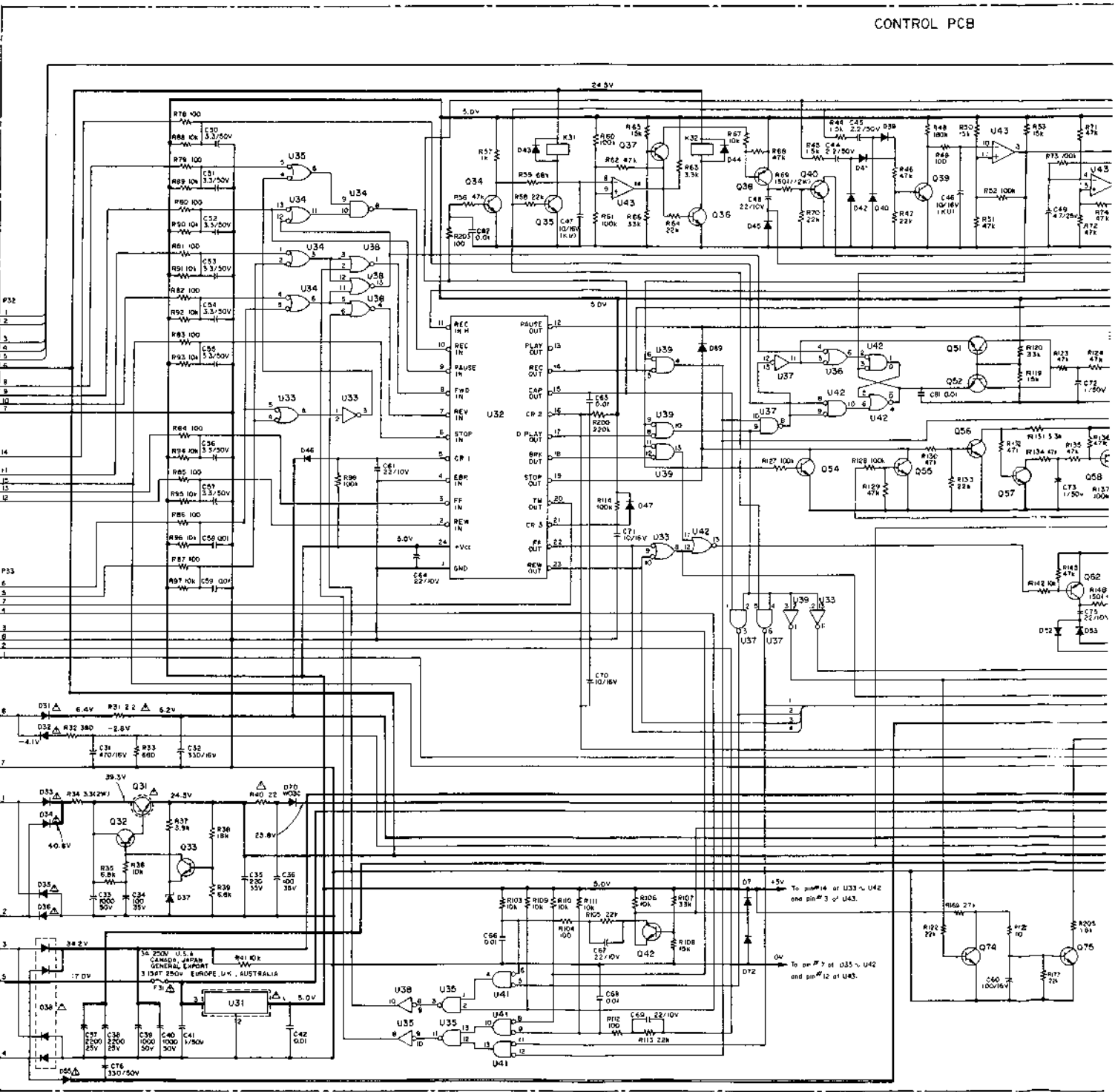
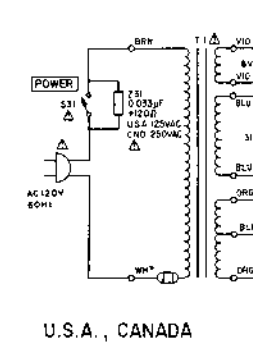
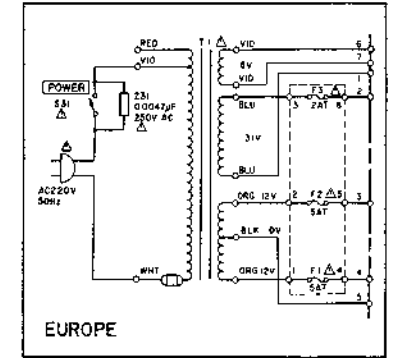
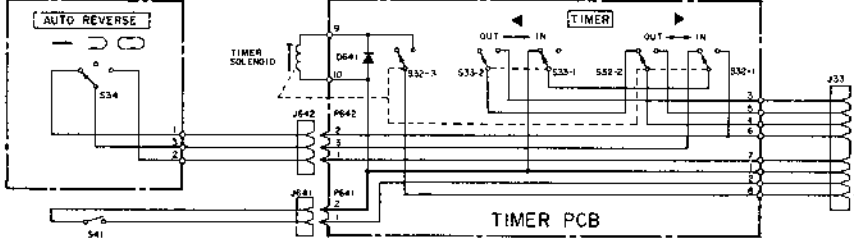
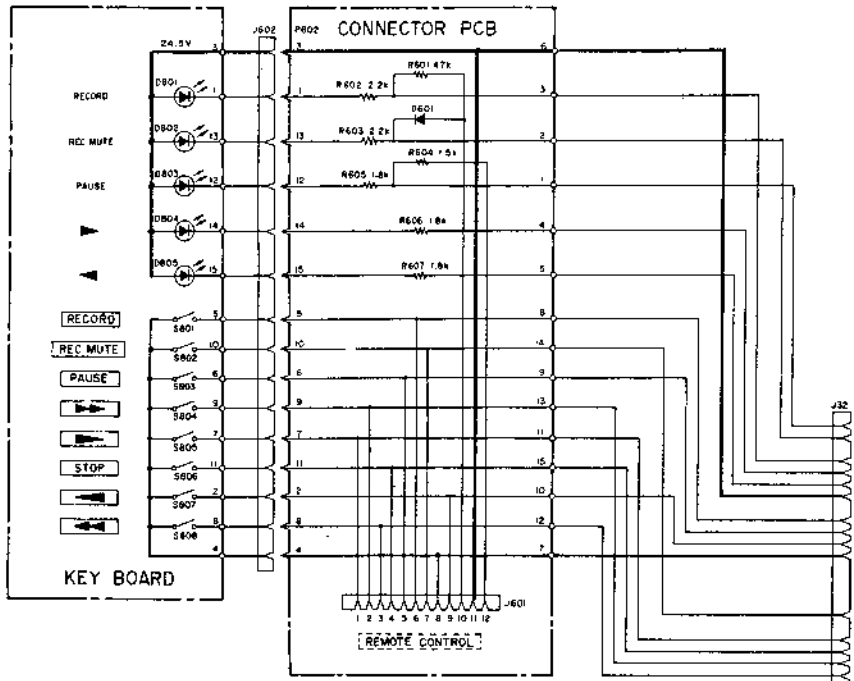
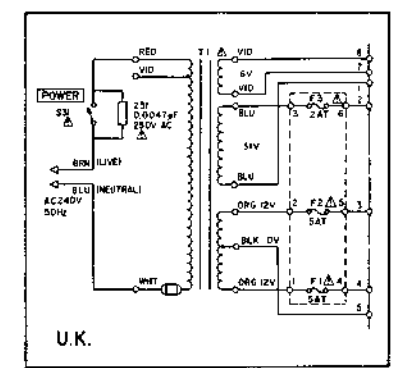
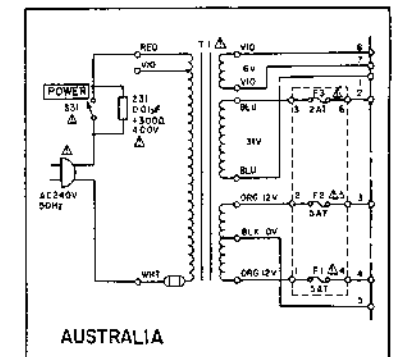
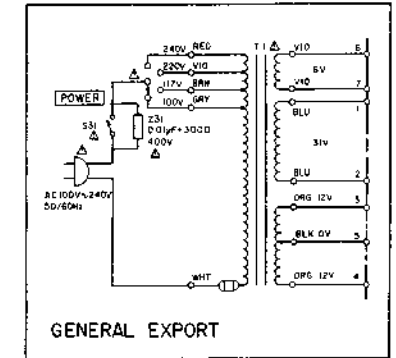

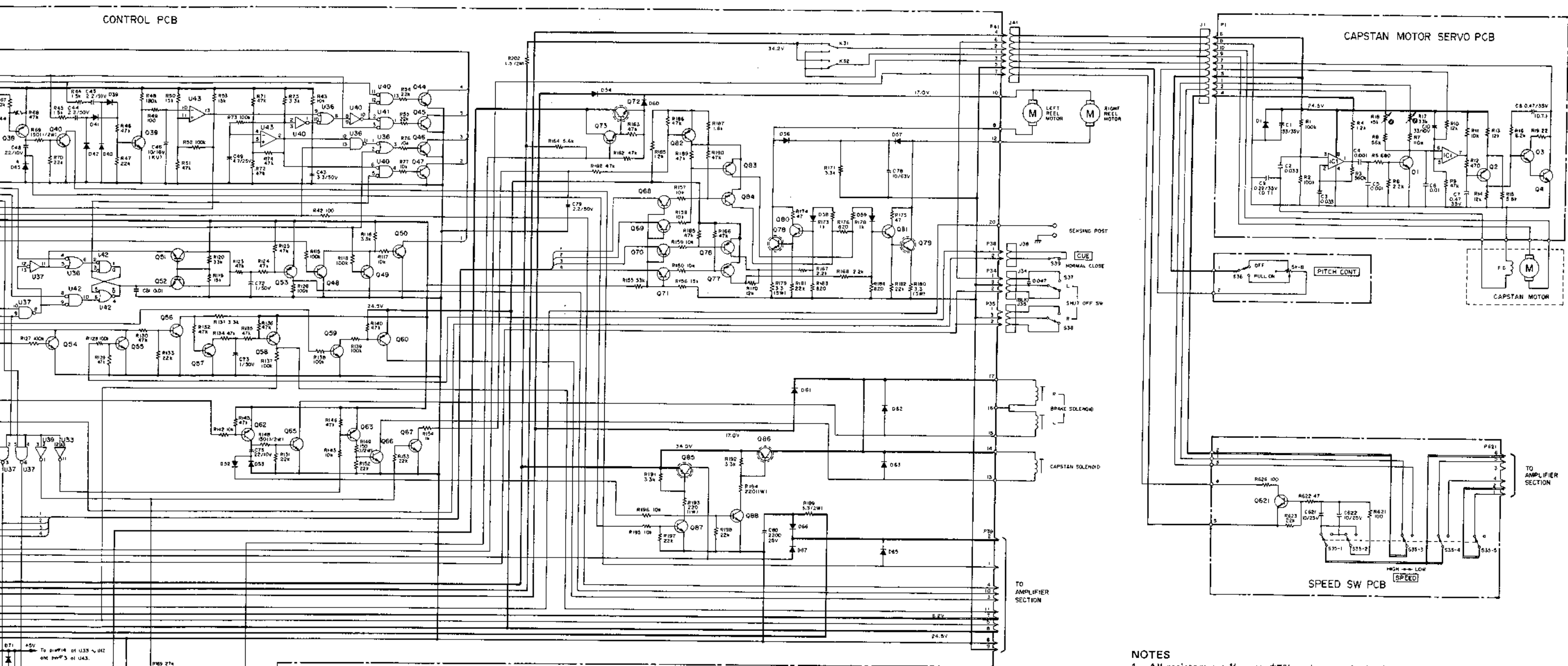

CONTROL PCB		CAPSTAN MOTOR SERVO PCB		SPEED SW PCB	
U31	NUM78MSA	Q68	2SC236F	D71 - D76	ERB12 0201
U32	4M9201	Q69	2SA732P	Q17	EQ401 046
U33	HD7400P	Q70	2SA1127R	Q38	MAG 83
U34	HD7400P	Q71	2SA732P (GE)	Q39 - Q42	1S2473M
U35	NUM201N	Q72	2SC1061C (All except GE)	Q43, Q44	ERB12 0201
Q31	2SD213E	Q73	2SC1885R	Q45 - Q47	1S2473M
Q32	2SC1318B	Q74	2SC1885R	Q48, Q49	1S2473M
Q33	2SC1885R	Q75	2SA732P	Q50, Q51	1S2473M
Q34, Q35	2SC236F	Q76	2SA1127R	Q52	UMC
Q36, Q37	2SC1885R	Q77	2SC1318B	Q53 - Q57	ERB12 0201
Q38	2SA1127R	Q78, Q79	2SD213E	Q58, Q59	1S2473M
Q39	2SC1885R	Q80, Q81	2SC1318B	Q60	ERB12 0201
Q40	2SC1885R	Q82 - Q84	2SA1127R	U701	NUM201N
Q41 - Q43	2SC1885R	Q85, Q86	2SC236F	U702	1S2473M
Q44 - Q46	2SC1885R	Q87, Q88	2SA1127R	CONNECTOR PCB	
Q47, Q48	2SC236F			Q801	1S2473M
Q49	2SA1127R				
Q50 - Q54	2SC1885R				
Q55	2SC236F				
Q56	2SA1127R				

INSTRUCTIONS FOR SERVICE PERSONNEL

BEFORE RETURNING APPLIANCE TO THE CUSTOMER, MAKE LEAKAGE-CURRENT OR RESISTANCE MEASUREMENTS TO DETERMINE THAT EXPOSED PARTS ARE ACCEPTABLY INSULATED FROM THE SUPPLY CIRCUIT.

- NOTES**
1. All resistors are 1/4 watt, ±5%, unless marked otherwise. Resistor values are in ohms (k = 1,000 ohms).
 2. All capacitor values are in microfarads (p = picofarads).
 3. ⚠ Parts marked with this sign are safety critical components. They must always be replaced with identical components-refer to the TEAC parts list and ensure exact replacement.
 4. Each Voltage value shown above is the one measured in REC/PAUSE position and each mode.
 5. : front panel indication
 6. : rear panel indication
 7. +B power supply circuit

X-700R
Stereo Tape Deck
 September, 1983

TEAC SCHEMATIC DIAGRAM (AMPLIFIER) X-700R

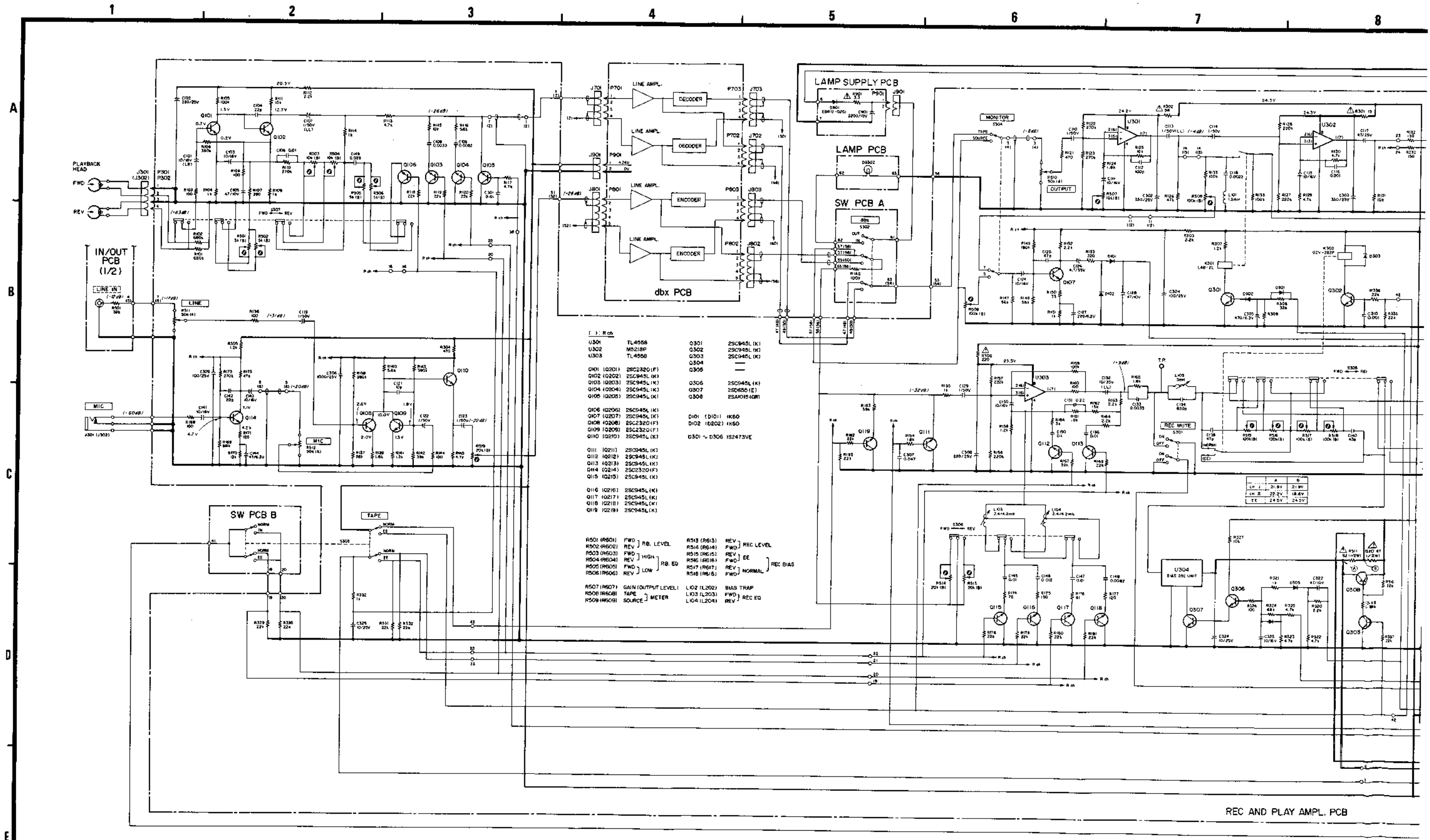

REC AND PLAY AMPL. PCB

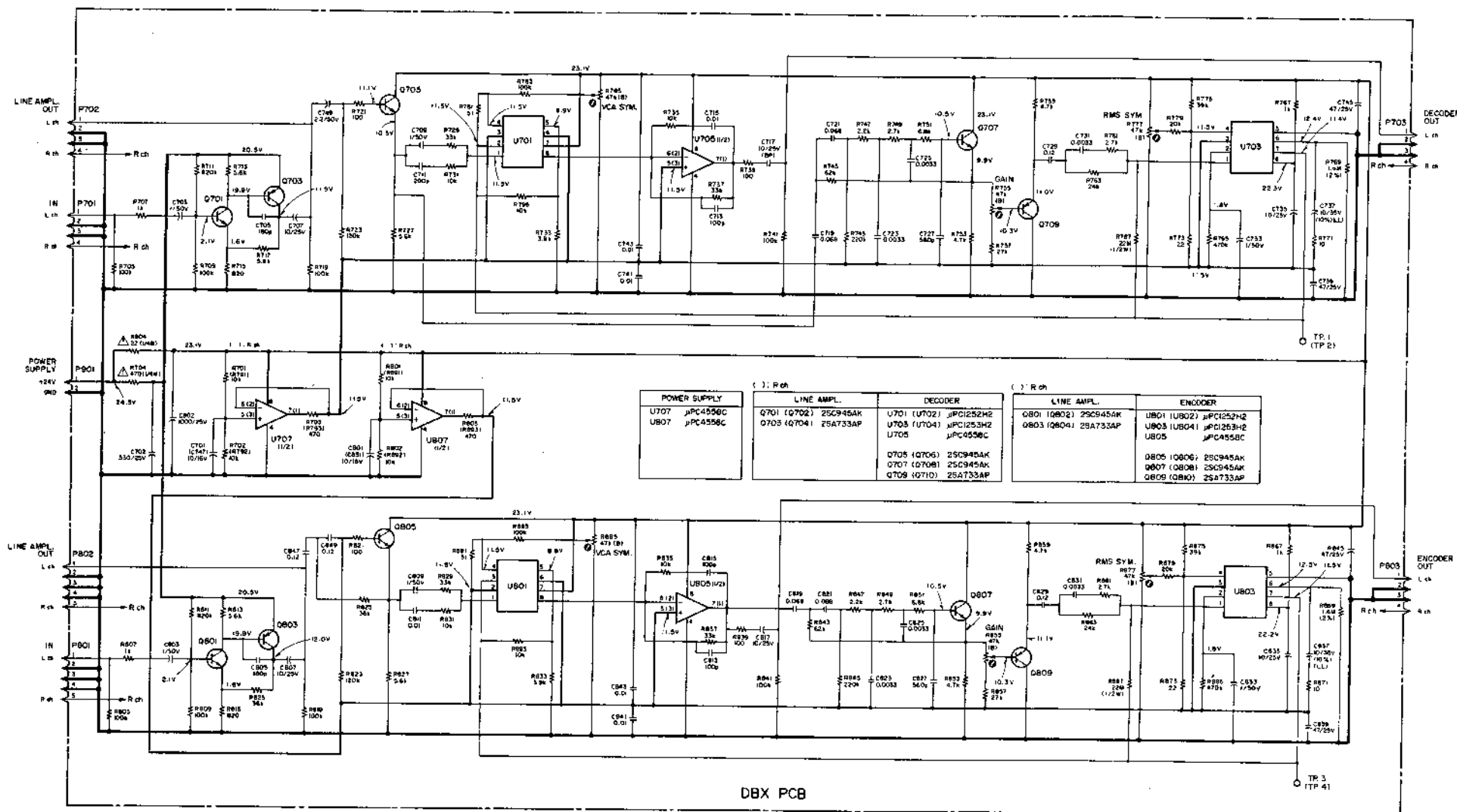
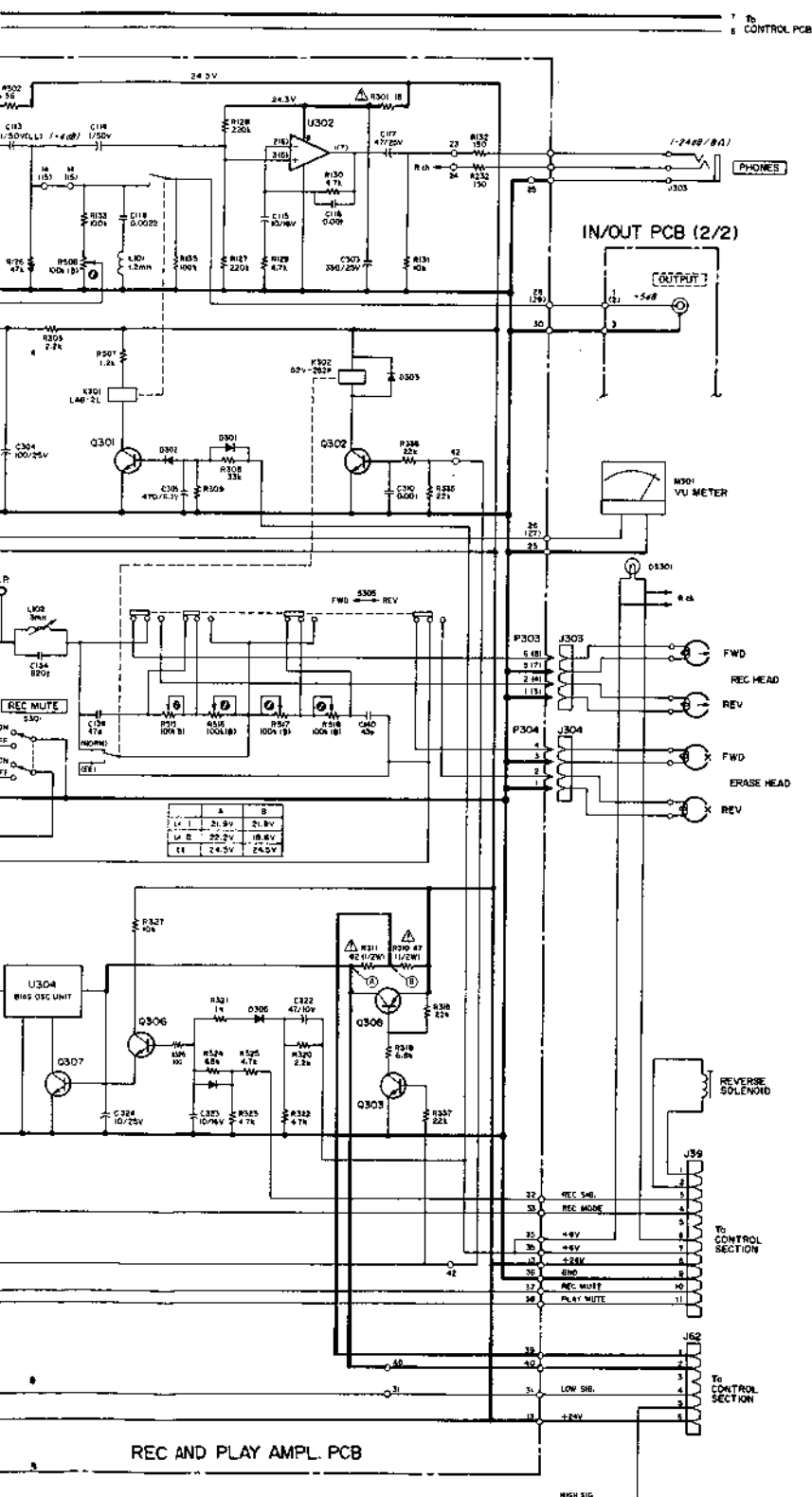

NOTES

1. Schematic diagram shown for left channel except for some of the components.
2. All resistors are 1/4 watt, $\pm 5\%$, unless marked otherwise. Resistor values are in ohms (k = 1,000 ohms).
3. All capacitor values are in microfarads (p = picofarads).
4. Δ Parts marked with this sign are safety critical components. They must always be replaced with identical components—refer to the TEAC parts list and ensure exact replacement.
5. Voltage and level values are for reference only. 0dB = 0.775V. Indicated values are those existing when the meter indicates 0VU.
6. : front panel indication
7. : rear panel indication
8. +B power supply circuit

INSTRUCTIONS FOR SERVICE PERSONNEL
 BEFORE RETURNING APPLIANCE TO THE CUSTOMER, MAKE LEAKAGE-CURRENT OR RESISTANCE MEASUREMENTS TO DETERMINE THAT EXPOSED PARTS ARE ACCEPTABLY INSULATED FROM THE SUPPLY CIRCUIT.

X-700R
 Stereo Tape Deck
 September, 1983

X-700R

TEAC®

TEAC CORPORATION

3-7-3 NAKA-CHO MUSASHINO TOKYO PHONE (0422) 53-1111

TEAC CORPORATION OF AMERICA

7733 TELEGRAPH ROAD MONTEBELLO CALIFORNIA 90640 PHONE (213) 726-0303

TEAC AUSTRALIA PTY., LTD.

115 WHITEMAN STREET SOUTH MELBOURNE VICTORIA 3205 PHONE 699-6000

PRINTED IN JAPAN 0983 AO 1.65 D-4442A