

TEAC®

SERVICE MANUAL

X-1000M/X-1000

Stereo Tape Deck

X-1000 は海外専用モデルです。

dbx noise reduction system made under license from dbx, Incorporated. The word dbx and the dbx Symbol are trademarks of dbx, Incorporated.

△ Parts marked with this sign are safety critical components. They must always be replaced with identical components — refer to the appropriate parts list and ensure exact replacement.

1 SPECIFICATIONS AND SERVICE DATA

SPECIFICATIONS

Track System

- X-1000M:** 2 track, 2 channel stereo or mono
4 track playback switchable
X-1000: 4 track, 2 channel stereo or mono

Head System

- X-1000M:** 4 heads: erase, record, 2T playback and 4T playback
X-1000: 3 heads: erase, record, playback

Reel Size 10-1/2" and 7"

Tape Speed

- X-1000M:** 38cm/s (15 ips) and 19cm/s (7-1/2 ips)
X-1000: 19cm/s (7-1/2 ips) and 9.5cm/s (3-3/4 ips)

Inputs (level and impedance)

- MIC:** Specified input level: -60dB (0.775mV)/10kohms
Min. input level: -70dB (245µV)
LINE IN: Specified input level: -12dB (195mV)/50kohms
Min. input level: -22dB (61.5mV)

Outputs (level and impedance)

- OUTPUT:** Specified output level: -5dB (436mV)/10kohms
Max. output level: +1dB (0.869V)
PHONES: Specified output level: -24dB (48.9mV)/8ohms

Playback equalization

	"LH" tape	"EE" tape
38cm/s:	3,180µs + 50µs ∞ + 35µs (IEC)	3,180µs + 35µs
19cm/s:	3,180µs + 50µs	3,180µs + 35µs
9.5cm/s:	3,180µs + 90µs	3,180µs + 50µs

Motors

- Capstan motor:** FG servo DC motor
Reel motor: 2 DC slotless motors

Bias Frequency 100kHz

Power Requirements

- 100/120/220/240V, AC 50/60Hz 110W (General export model)
220V AC 50Hz, 110W (Europe model)
240V AC 50Hz, 110W (U.K./Australia model)
120V AC 60Hz, 110W (U.S.A./Canada model)

Weight 22.0kg (48-8/16 lbs) net

26kg (57-5/16 lbs) (with wooden case)

Dimensions See Fig. 1-1 on page 3.

SERVICE DATA

MECHANICAL

Tape Speed Deviation 3,000Hz ± 30Hz

Tape Speed Drift 15Hz

Wow and Flutter

- Playback:** 38cm/s: 0.04% (WRMS), 0.08% (RMS)
19cm/s: 0.05% (WRMS), 0.10% (RMS)
9.5cm/s: 0.07% (WRMS), 0.12% (RMS)
Record/Playback: 38cm/s: 0.10% (RMS)
19cm/s: 0.12% (RMS)
9.5cm/s: 0.15% (RMS)
Pinch Roller Pressure 1.35kg ~ 1.9kg (3.0 lbs ~ 4.2 lbs)

Tape Tension

Play mode:

- Take-up:** 50g ± 10g (1.4oz ~ 2.1oz)
Supply: 50g ± 10g (1.4oz ~ 2.1oz)

Fast winding mode

- Take-up:** 110g ± 10g (3.5oz ~ 4.2oz)
Supply: _____

Brake Torque

- Forward direction:** 1.2 ~ 1.9kg-cm (17 ~ 26oz-inch)
[X-1000M]
1.2 ~ 1.7kg-cm (17 ~ 24oz-inch)
[X-1000]
Reverse direction: 0.7kg-cm (9.7oz-inch) or less
[X-1000M]
0.6kg-cm (8.3oz-inch) or less
[X-1000]

Left/right deviation: 0.2kg-cm (2.8oz-inch) or less

Fast Winding Time 100 seconds or less for 550m (1800 feet)

Pitch Control Standard tape speed ± 6% or more

TIMER Activate Time 4 sec. ± 2 sec.

ELECTRICAL

Frequency Response

Refer to the specifications in "3 ELECTRICAL ADJUSTMENTS AND CHECKS".

Signal to Noise Ratio

Playback:	LH-I, -II	EE
38cm/s:	50dB min.	52dB min.
19cm/s:	50dB min.	52dB min.
9.5cm/s:	49dB min.	52dB min.
Overall:	38cm/s: 48dB min.	50dB min.
	19cm/s: 48dB min.	50dB min.
	9.5cm/s: 46dB min.	50dB min.

Overall (dbx): 65dB min. (All speeds, various EQ tapes)

Erase Efficiency At 1kHz (measured with input 10dB higher than the specified input level)

- 38cm/s: 65dB min.
19cm/s: 70dB min.
9.5cm/s: 70dB min.

Channel Separation 50dB min. at 1kHz

Adjacent Track Crosstalk 40dB min. at 125Hz

Total Harmonic Distortion At 1kHz, and at HIGH speed

- 0.8% or less (LH-I, LH-II, EE)
0.8% or less (dbx IN)
3% or less (dbx IN + 20VU)

- Improvements may result in SPECIFICATIONS AND SERVICE DATA changes.
- Value of "dB" in the data refers to 0dB (0.775V), except where specified.

2 MECHANICAL ADJUSTMENTS AND CHECKS

2-1 ROTATING PART THRUST CLEARANCE CHECKS

Reference values

Capstan shaft:	0.1mm to 0.25mm (magnefloat type)
Guide roller:	0.05mm to 0.3mm
Tension arm guide roller:	0.05mm to 0.3mm
Reel motor:	0 (spring type)
Tension arm:	0 (spring type)

NOTE: Since the capstan shaft is a magnefloat type, check that it is forced towards the rear of the deck while rotating.

2-2 BRAKE ADJUSTMENT

NOTE: The explanation and figure in this paragraph are for the left side brake, similar checks and adjustments are applicable for the right side one.

- Adjust by moving the brake band bracket in either direction (arrow (A)) so that the reel motor chassis is in parallel with the brake arm, and so that the brake band makes proper clearance equally all around the reel table base.
- Adjust by moving the brake solenoid in either direction (arrow (D)) so that the stroke of the solenoid plunger is about 2mm.
- Adjust by moving the band ass'y retaining plate as shown in (B, C, E) so that, when the plunger is pushed in the direction of the solenoid housing, the reel table base is not rubbed by the brake band and is properly spaced.

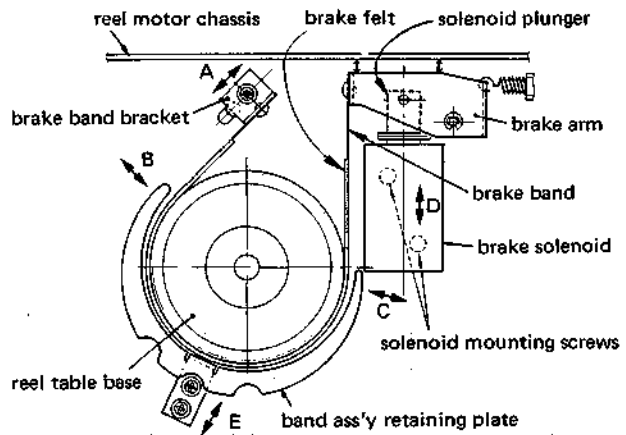
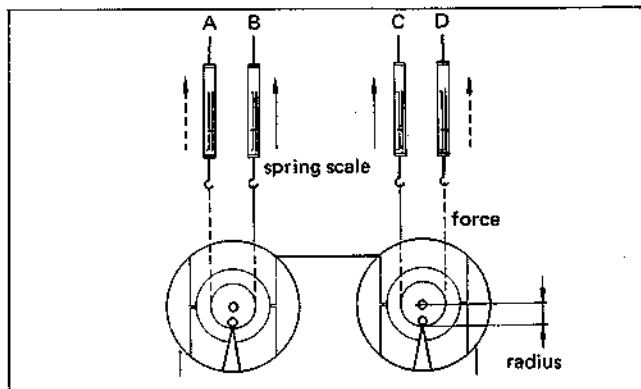

Fig. 2-1

2-3 BRAKE TORQUE MEASUREMENT

- Place an empty 7" reel, connected to a spring scale by a string, on the reel table.
- Pull the scale away from the reel and read the scale indication only when the reel table is steady motion.
- Do steps 1 and 2 for each measuring condition, (A) through (D) in Fig. 2-2.
- The values are as chart in Fig. 2-2.



↑ Forward direction (B) (C)	1.2 to 1.9kg-cm (17 to 26oz-inch) [X-1000M]
	1.2 to 1.7kg-cm (17 to 24oz-inch) [X-1000]
↑ Reverse direction (A) (D)	0.7kg-cm (9.7oz-inch) or less [X-1000M]
	0.6kg-cm (8.3oz-inch) or less [X-1000]
Left/right deviation	0.2kg-cm (2.8oz-inch) or less

- NOTES:**
- The reverse direction values are reference.
 - The specification of left/right deviation only applies for forward direction torques.

Torque calculating formulas:

- Torque (in g-cm or oz-inch) = Force or Weight (in g or oz) x Radius (in cm or inch)
- Conversion of g-cm to oz-inch: g-cm x 0.0139 = oz-inch

Fig. 2-2

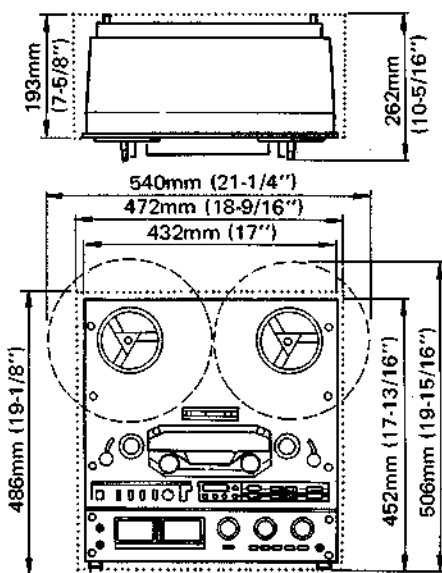

Broken line indicates General Export Models for Limited Areas.

Fig. 1-1 Dimensions

2-4 PAUSE POSITION ADJUSTMENT

1. Place the deck in the pause mode.
2. Adjust by turning the pause positioning nut so that the clearance between the capstan shaft and the tape is 0.5mm to 1.0mm.
3. Of the two capstan shaft/pinch rollers, adjustment is allowable only for the side having the narrower clearance.
4. Check that, by repetition of play mode to pause mode and stop mode to pause mode, there is clearance at both sides.

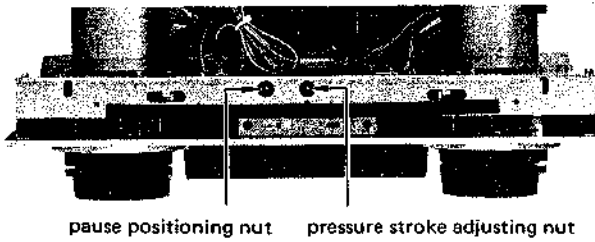

Fig. 2-3 Pause position and pinch roller pressure stroke adjustments

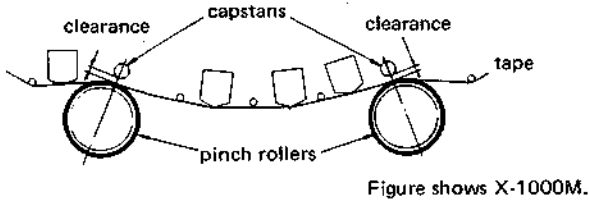
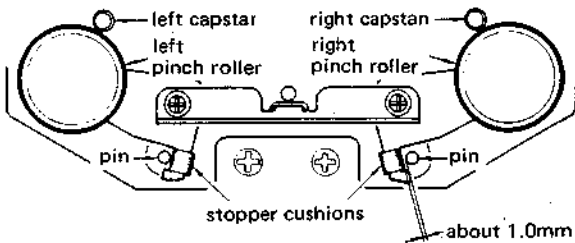

Fig. 2-4 Pause position adjustment

2-5 PINCH ROLLER PRESSURE STROKE ADJUSTMENT

1. Set the deck in the play mode.
2. Adjust by turning the pressure stroke adj. nut (Fig. 2-3) so that the clearance between the pin and the stopper cushion is about 1.0mm.
3. Since the clearance is produced at one side (left or right), adjustment for this side only is permissible.



Either the left or right should have a clearance of about 1.0mm.

Fig. 2-5

2-6 PINCH ROLLER PRESSURE MEASUREMENT

- NOTES: 1. The explanation below applies to both the left and right pinch rollers.
2. Both pinch roller pressures are automatically set with equal value.

1. Hold both the left and right tension arms in the upper positions using rubber bands, string etc.
2. Set the deck in the play mode with no tape loaded.
3. Attach the spring scale to the pinch roller as shown in the figure.
4. Draw the pinch roller away from the capstan shaft (in the direction of a line intersecting the centers of the capstan shaft and the pinch roller) until the capstan shaft and the pinch roller are separated.
5. Return the scale back until the pinch roller just begins to turn. The scale should then be reading as follow.
Reference value: 1.35kg to 1.9kg (3.0 lbs to 4.2 lbs)
6. If the reading is out of specification, replace defective part(s). There are no adjustable parts.

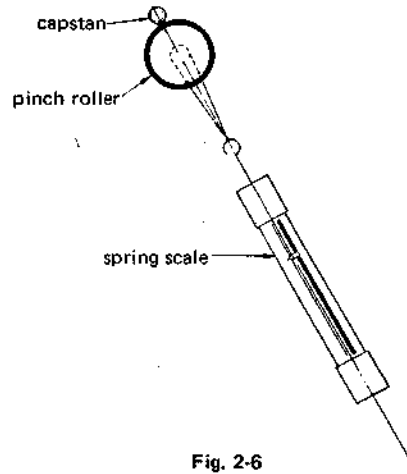

Fig. 2-6

2-7 CAPSTAN MOTOR REPLACEMENT

1. When replacing the capstan motor, install as shown in illustration.

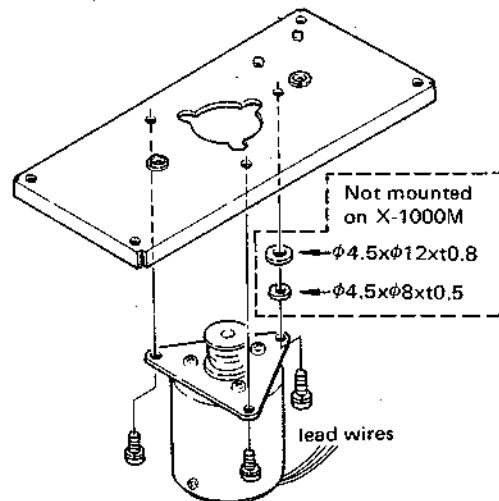
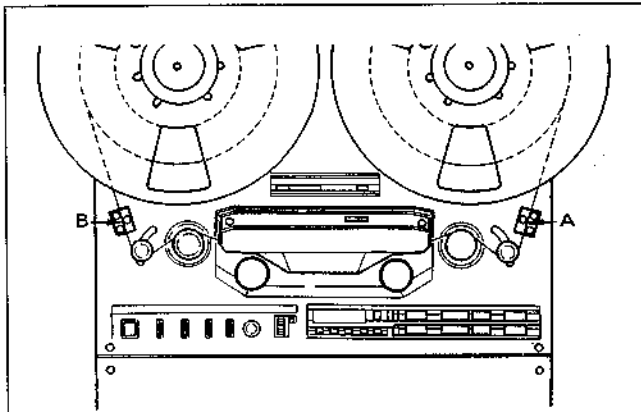

Fig. 2-7

2-8 TAPE TENSION



Tape tension value

NOTE: Alphabet letters in parentheses indicates measuring point shown in figure.

Play mode

Take-up: (A) in FWD	50g ± 10g (1.4oz ~ 2.1oz)
Supply: (B) in FWD	50g ± 10g (1.4oz ~ 2.1oz)

Fast winding mode

Take-up: (A) in F.F. (B) in REW	110g ± 10g (3.5oz ~ 4.2oz)
Supply: (B) in F.F. (A) in REW	This value is automatically set when doing "2-9 FAST WINDING SPEED" adjustment.

Fig. 2-8

- NOTES:**
- Since these settings are precisely factory adjusted, in general, they should not be re-adjusted. If it is specifically required, a special meter is needed.
 - To facilitate adjustment, the deck should be placed in a vertical position.
 - For the reels mounted on both left and right reel tables, use the same size ones.
 - Before all the following adjustments (2-8-1 ~ 2-8-3), perform next instructions in order to activate the relevant circuit.
 - Thread the tape to lift up both tension/shut-off arms.
 - Set the POWER switch to ON.
 - Leave the deck as it is for 5 to 10 minutes.
 - There should be almost equal values between tape tension at point A during fast forward mode and at point B during rewind mode.

2-8-1 IN PLAY MODE

- Place a reel loading TEAC YTT-8013 test tape on the left reel table and an empty reel on the right reel table, then thread the tape.
- Let the tape run in fast forward mode until both reels have nearly the same tape winding diameter.
- During play at a LOW speed, measure tape tension at point A.
- Adjust R120 so that the specified tape tension of 50g ± 10g (1.4oz ~ 2.1oz) is obtained.

2-8-2 IN FAST FORWARD MODE

- Load a TEAC YTT-8013 test tape on the left reel table and an empty reel on the right reel table, then thread the tape.
- Stop the left reel by hand and set the deck in fast forward mode.
- Adjust R237 to obtain a 100g to 120g (3.5oz ~ 4.2oz) value at point A (Obtain a 100g or 3.0oz value as far as possible).

2-8-3 IN REWIND MODE

- Load a TEAC YTT-8013 test tape on the right reel table and the empty reel on the left reel table, then thread the tape.
- Stop the right reel by hand and set the deck in the rewind mode.
- Adjust R238 to obtain a 100g to 120g (3.0oz ~ 3.6oz) value at point B (Obtain a 100g or 3.5oz as far as possible).

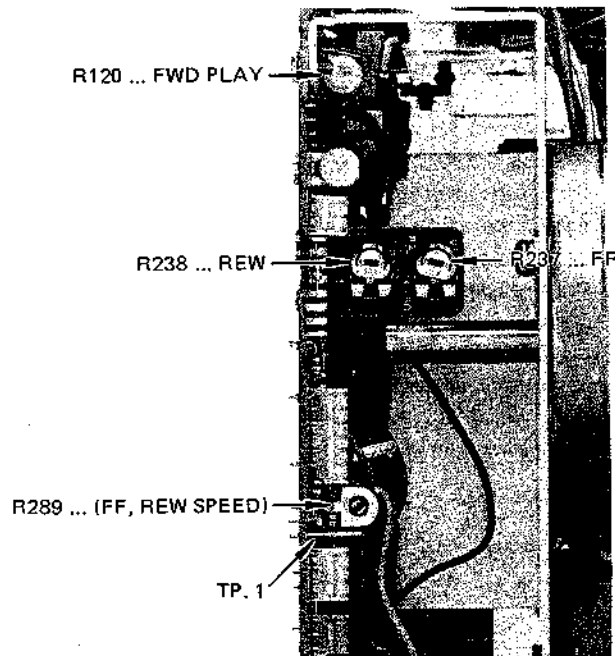

Fig. 2-9 Tape tension adjuster location

2-9 FAST WINDING SPEED

1. Set the deck in vertical position.
2. Connect oscilloscope between TP1 test point on the POWER SERVO PCB and ground.
3. Thread a TEAC YTT-8013 test tape. In this case, either use of 7 inch reels or 10 inch are permitted provided both left and right reels are the same size.
4. During fast forward or rewind mode, adjust R289 so that wavelength displayed on the oscilloscope becomes 7msec. Adjustment should be satisfied at any tape winding position.
5. Check that almost equal value of fast winding speed is obtained between fast forward and rewind modes.

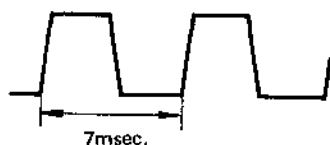

Fig. 2-10 Waveform at TP1

2-10 TENSION ARM HEIGHT ADJUSTMENT

1. Thread any standard tape on the deck using a standard empty reels such as TEAC RE-1002.
2. Set the deck in the forward play or fast-forward (fast rewind) mode.
3. Stop left (right) guide roller's rotation by hand. Adjust by turning the left (right) tension arm height adjusting nut (refer to Fig. 2-11) so that the tape moves in the center of the guide roller.
4. Release the guide roller. Fine-adjust the adjust nut again so that there is no evident tape curling on the left-most (right-most) tape guide pin of the head assembly.
5. After adjusting the height of both left and right tension arms, check that the tape running condition is good by switching between fast forward and rewind modes.
6. If the tape running position is different when the guide roller stops and when it turns, the condition when the guide roller is rotating has priority.

Figure shows left side tension arm.

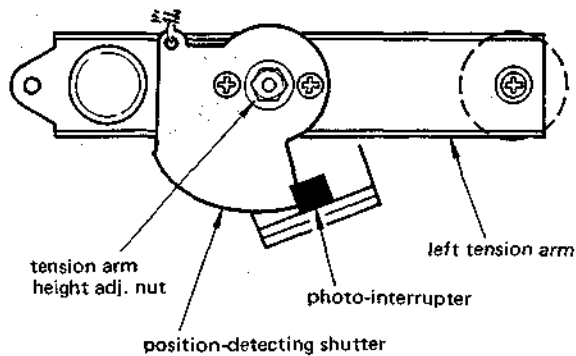

Fig. 2-11

2-11 REEL TABLE HEIGHT ADJUSTMENT

1. Adjust the tension arm height beforehand (See 2-10).
2. Check each reel table height using a TEAC RE-1002 empty reel and letting the tape run in each tape operating mode.
3. If the tape rubs against the reel flanges, adjust the reel table height by means of the two reel table mounting screws.

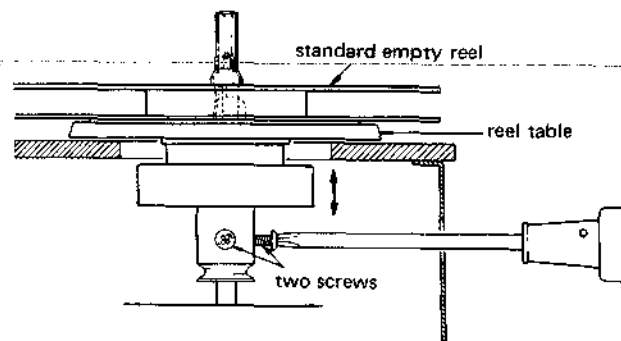

Fig. 2-12

2-12 HEAD AND TAPE PATH ALIGNMENTS

NOTE:

The adjustments referred to in this section are so closely related to one another that it is necessary to re-check the other adjustments after completion of one.

HEAD REGULATION ELEMENTS	EXAMPLE OF MISALIGNMENT
TILT The head surface should be parallel to the tape guide pin surface.	
AZIMUTH The gap of the head core should be perpendicular to the tape travel.	
HEIGHT (2T) The head cores should be equally distant from the upper and lower edges of the tape.	
HEIGHT (4T) The top edge of the upper core of the head should be level with the upper edge of the tape.	
TANGENCY The dotted line should be perpendicular to the surface of the tape.	

Fig. 2-13 Head regulation elements

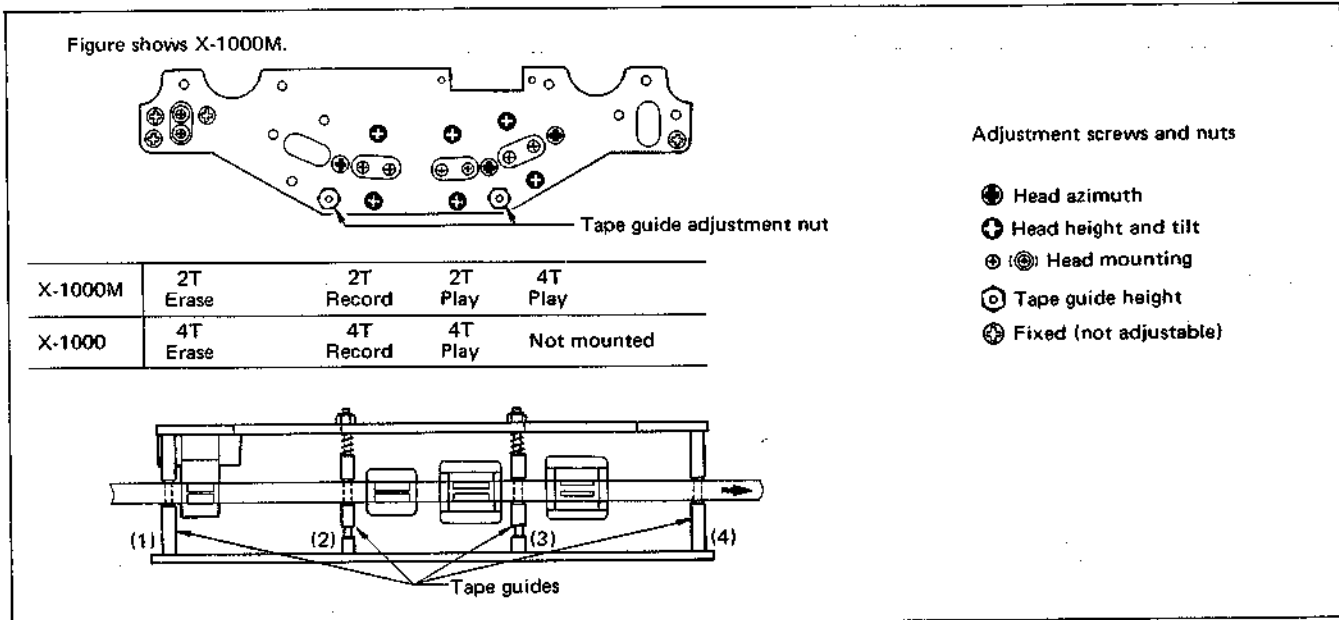

Fig. 2-14 Tape guide and head arrangement

2-12-1 COARSE ADJUSTMENT OF PINCH ROLLER PARALLELISM

The following procedure is for parallelism adjustment of left pinch roller. A similar procedure is also applied for the right pinch roller.

1. Let pinch roller draw near toward capstan shaft by manually lifting up tape lifter shown in Fig. 2-15.
2. Check pinch roller/capstan shaft parallelism viewed from direction of arrow A shown in Fig. 2-15. Refer to Fig. 2-16.
3. If not parallel, loosen the reinforcement plate screw near the correction-required side (Refer to Fig. 2-18), then correct tilt of pinch roller spindle using correction jig. Adjustment can be done by tilting correction jig in direction of arrow A or A'.

NOTE:

- (1) Use the jig as near as possible to the pinch roller spindle.
- (2) Do not touch the surface of spindle.
- (3) Use no other tool for this adjustment!
4. Remove pinch roller, then push up tape lifter to visually align pinch roller spindle with the capstan shaft viewed from direction of arrow B in Fig. 2-15.
5. If needed, adjust by tilting correction jig in direction of arrow B or B' in Fig. 2-18.

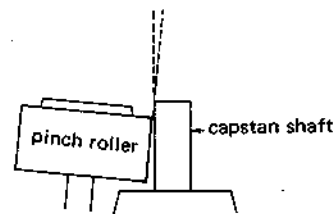

Fig. 2-16 View in direction A (example of non-parallelism)

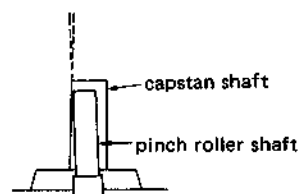

Fig. 2-17 View in direction B (example of non-parallelism)

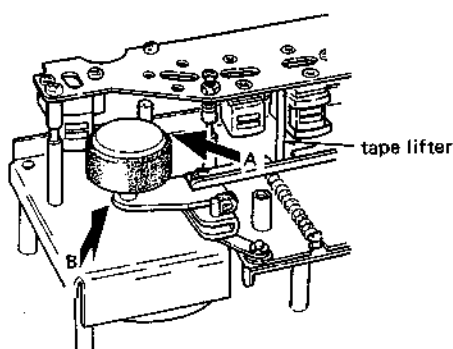

Fig. 2-15 Directions for pinch roller parallelism check

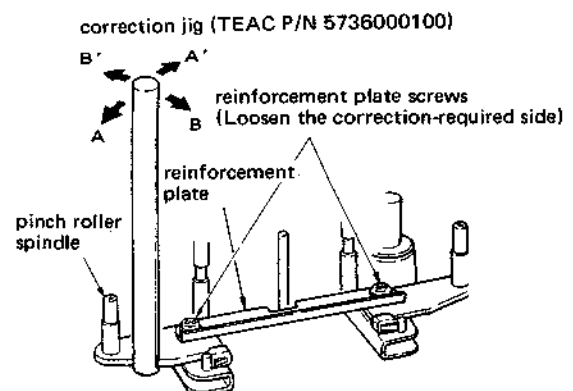

Fig. 2-18 Pinch roller/capstan alignment

2-12-2 HEAD TILT AND AZIMUTH ADJUSTMENT

1. Visually adjust the tilt of playback and record heads so that the head surface is parallel to the nearest tape guide or capstan shaft.
2. Make coarse azimuth adjustments for the record and playback head, viewing each head from front (without tape).

2-12-3 TAPE GUIDE HEIGHT ADJUSTMENT

1. Playing a TEAC YTT-8013 test tape (thickness = 35 μ m), adjust the height of the left tension arm so that the lower edge of the tape is just touching the lower edge of the tape guide (1). See Fig. 2-19. Also refer to "2-10 TENSION ARM HEIGHT ADJUSTMENT".
2. Adjust the height of the tape guide (2) so that the upper edge of the tape is in contact with the upper edge of the tape guide.
3. Confirm that the adjustments do not cause the tape to curl.
4. Adjust height of tape guides (3) and (4) in the same way as steps 1 ~ 3. For tape guide (4), adjust right tension arm height.
5. Check to see there is no tape curling at all the tape guides.
6. Apply locking paint to the height adjust nut of tape guides (2) and (3).

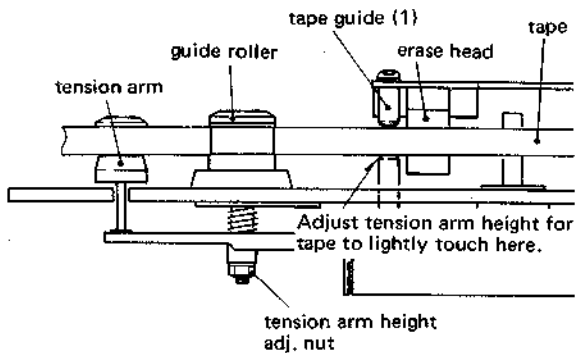

Fig. 2-19 Tension arm height adjustment

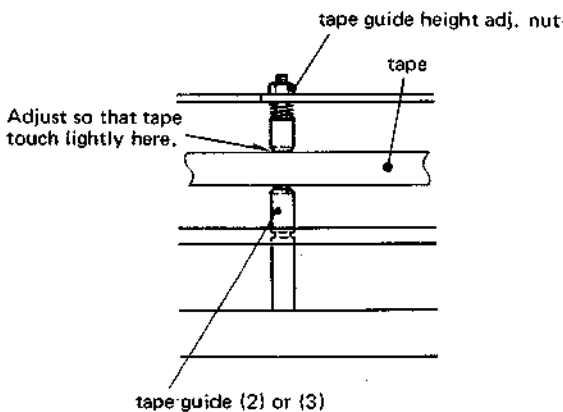

Fig. 2-20 Tape guide height adjustment

2-12-4 FINE ADJUSTMENT OF PINCH ROLLER PARALLELISM

With HIGH tape speed, each pinch roller should satisfy the following requirements.

1. Remove pinch roller cap.
2. Manually move pinch roller upwards (along pinch roller spindle) by 1 ~ 2mm from the stop portion of the spindle, then play a test tape.
3. During play mode, observe whether the pinch roller position changes in the spindle direction.
4. If a change is found, re-adjust accurately tilt of pinch roller spindle by method illustrated in Fig. 2-18.

2-12-5 HEAD HEIGHT ADJUSTMENT

1. On X-1000M model, fine-adjust the height of the 2T record and 2T playback heads so that their head cores are equally distant from the upper and lower edges of the tape.
2. Fine-adjust the height of the 4T record and 4T playback head(s) so that the head's brass-colored spacer shows just above the moving tape (about the thickness of a thin pencil line).

2-13 TAPE SPEED ADJUSTMENT

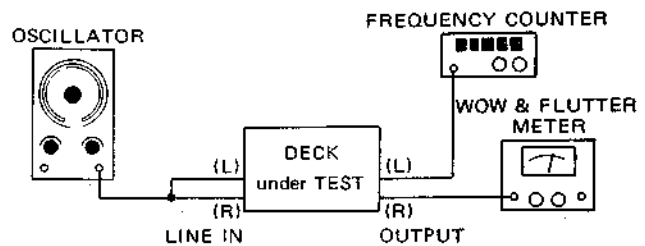

Fig. 2-21

TEAC Tape Speed and Flutter test tapes:

- YTT-2004: For 38cm/s (15 ips) speed
- YTT-2003: For 19cm/s (7- $\frac{1}{2}$ ips) speed
- YTT-2002: For 9.5cm/s (3- $\frac{3}{4}$ ips) speed

1. Connect a frequency counter to either OUTPUT terminal.
2. Load a TEAC YTT-2004 (X-1000: YTT-2003) test tape. Set the SPEED switch—HIGH, and PITCH CONT knob—OFF.
3. Play the tape. Adjust HIGH SPEED control (see Fig. 2-22) for a reading of 3,000Hz \pm 5Hz.
4. Check the following at the beginning and the end of the tape.
Specifications:
Tape speed deviation 3,000Hz \pm 30Hz
Tape speed drift 15Hz
5. Change the test tape to a TEAC YTT-2003 (X-1000: YTT-2002), and SPEED switch setting to LOW.
6. Repeat steps 3 through 4. Adjust LOW SPEED control if necessary.
7. Pull the PITCH CONT knob out. Set SPEED switch HIGH. Play a YTT-2004 (X-1000: YTT-2003) tape.

- Check if the speed variation of at least $3,000\text{Hz} \pm 180\text{Hz}$ is obtained when the PITCH CONT knob is rotated fully in both directions.
- Change the test tape to YTT-2003 (X-1000: YTT-2002), SPEED switch setting to LOW. Repeat step 8.

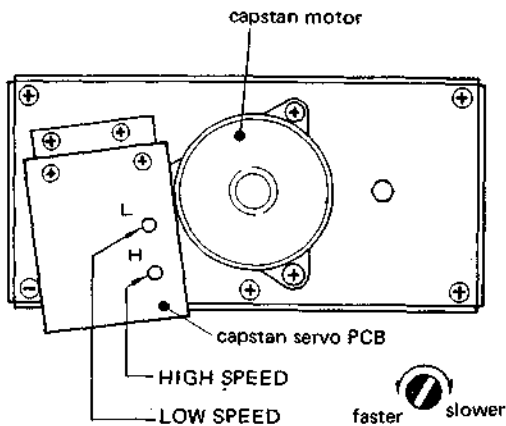

Fig. 2-22

2-14 WOW AND FLUTTER CHECKS

TEAC Tape Speed and Flutter test tapes:

Refer to the beginning of paragraph 2-13.

NOTE: The following measurements should be made at the beginning and the end of the tape.

Playback

- Connect the test equipment to the deck as shown in Fig. 2-21.
- Load and play a TEAC YTT-2004 (X-1000: YTT-2003) test tape for HIGH speed.
- Read the indication on the wow and flutter meter.
- Repeat steps 2 through 3 using a TEAC YTT-2003 (X-1000: TEAC YTT-2002) tape for LOW speed.

5. Wow and flutter specifications are as shown below.

X-1000M:	HIGH (38cm/s):	0.04% WRMS	0.08% RMS
	LOW (19cm/s):	0.05% WRMS	0.10% RMS
X-1000:	HIGH (19cm/s):	0.05% WRMS	0.10% RMS
	LOW (9.5cm/s):	0.07% WRMS	0.12% RMS

Overall

- Load a TEAC YTT-8013 test tape (blank). Apply and record a $3,000\text{Hz}$ signal.
- During simultaneous tape monitoring (playing) the recorded signal, read the wow and flutter meter display.

Specifications:

X-1000M:	HIGH (38cm/s):	0.10% RMS
	LOW (19cm/s):	0.12% RMS
X-1000:	HIGH (19cm/s):	0.12% RMS
	LOW (9.5cm/s):	0.15% RMS

2-15 LUBRICATION

Oiling is needed after every 1,000 hours of operation or once a year if the deck is infrequently used. For this purpose, TEAC spindle oil (from TEAC TZ-255 oil kit), Mobil D.T.E. Oil Light, etc. are recommended. Lubrication is normally not necessary except at the points shown.

- Place the deck in the horizontal position.
- Apply a few drops of oil to the respective spindles shown, excluding capstans, then spread the oil evenly on the spindle surfaces using a cotton cloth, etc.
- For capstans, apply a few drops to the indicated position.
- After oiling all the points, leave the deck for 1 to 2 hours until the oil is thoroughly absorbed.

Figure shows left side. Do also for right side.

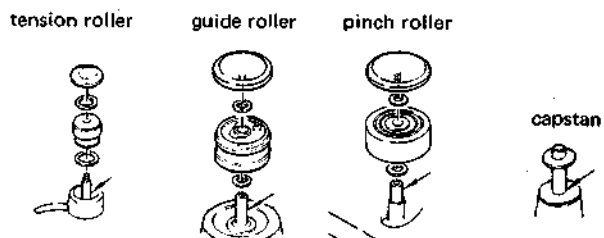

Fig. 2-23

2-16 VOLTAGE CONVERSION (FOR GENERAL EXPORT MODELS)

Always disconnect the power line cord before making these adjustments.

Frequency Conversion

Since the X series uses DC motors, frequency conversion is not necessary.

Voltage Conversion

- First remove the two feet by removing the screws in each one.
- Unscrew the left and right sides of the cabinet.
- Locate the voltage selector above the power transformer as seen from the rear of the deck.
- Remove the plug by pulling it out, then re-insert it so that the arrow on the plug is parallel with the white line indicating the proper voltage.
- Replace the cabinet and feet.

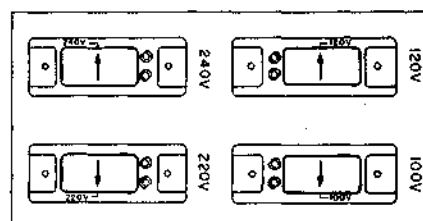

Fig. 2-24

3 ELECTRICAL ADJUSTMENTS AND CHECKS

NOTES:

1. Before performing adjustments and checks, clean and demagnetize the entire tape path.
2. Check that the deck is properly set for the voltage in your locality.
3. In general, adjustments and checks are done in the order of L-ch then R-ch. Double REF. Nos. indicate L-ch/R-ch.

(Example: R371/R372)

4. The value of "dB" refers to 0dB (0.775V). If an AC voltmeter calibrated to 0dB (1V) is to be used, appropriate compensation should be made.
5. The AC voltmeter used in the procedures must have an input impedance of 1M-ohms or more.

3-1 MONITOR PERFORMANCE

ITEM	CONNECTION	MODE/ INSTRUCTION	SIGNAL SOURCE	ADJUST (or CHECK)	RESULT	REMARKS	
1. Monitor level	1-1	OSC → ATT to LINE IN (L) AC voltmeter to REC AND PLAY AMPL. PCB term. #14.	DBX sw—OUT (Leave OUT up to step 27, "DBX PERFORMANCE" section). MONITOR—SOURCE MIC ATT—0 OUTPUT cont.—CAL LINE cont.—MAX MIC cont.—MIN	400Hz/-22dB (61.5mV) R369	-8dB (308mV)	LINE min. input level (L)	
	1-2	"	"	400Hz/-12dB (195mV) LINE cont. (L/R)	"	LINE spec. input level (L)	
	1-3	" but LINE IN (L) → LINE IN (R) #14 → #17	LINE spec. input level condition	"	R370	"	LINE spec. input level (R)
2. Output level	2-1	Fig. 3-1	LINE spec. input level condition	400Hz/-12dB (195mV) R403/R404	-5dB (436mV)		
3. VU meter	3-1	Fig. 3-1	LINE spec. input level condition	400Hz/-12dB (195mV) R371/R372	0VU on VU meter		
4. MIC input level	4-1	Fig. 3-1, but LINE IN → MIC	LINE cont.—MIN MIC cont.—MAX	400Hz/-70dB ±2dB (195μV ~ 308μV) Check	-5dB (436mV)	MIC min. input level	
	4-2	"	"	400Hz/-60dB (0.775mV) MIC cont. (L/R)	"	MIC spec. input level	
	4-3	"	MIC cont.—In the above set position MIC ATT—20	"	Check	-25dB ±1dB (38.8mV ~ 48.9mV)	
	4-4	Fig. 3-1	LINE cont.—spec. position (Item 1-2) MIC cont.—MIN MIC ATT—0	-	-	-	IMPORTANT: Do not disturb these cont's during later checks.

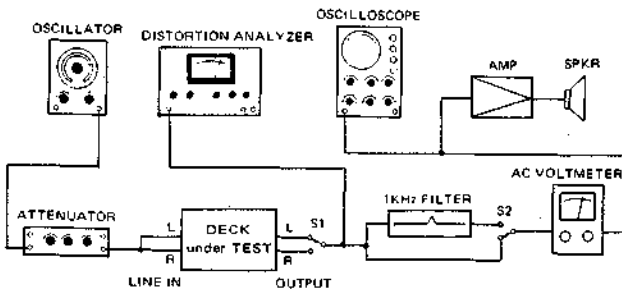

Fig. 3-1 Basic connection

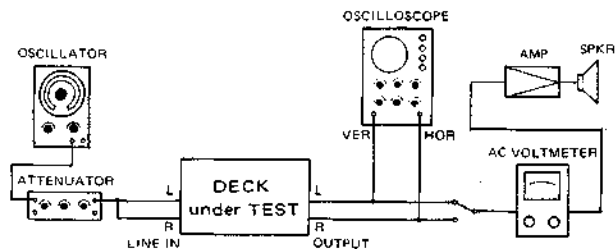

Fig. 3-2 Connection for phase check

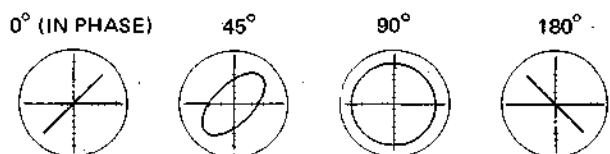

Fig. 3-3 Confirming phase relationship

TEAC test tapes:

For playback alignment

YTT-1004: For 38cm/s (15 ips), LH-II

YTT-1003: For 19cm/s (7½ ips), LH-II

YTT-1002: For 9.5cm/s (3¾ ips), LH-II

YTT-1054: For 38cm/s (15 ips), EE

YTT-1053: For 19cm/s (7½ ips), EE

YTT-1052: For 9.5cm/s (3¾ ips), EE

For recording alignment (blank)

YTT-8013: For LH-II

YTT-8053: For EE

3-2 PLAYBACK PERFORMANCE

ITEM	CONNECTION	MODE/ INSTRUCTION	SIGNAL SOURCE	ADJUST (or CHECK)	RESULT	REMARKS
5. Playback head azimuth	5-1 Fig. 3-2	MONITOR-TAPE SPEED-19cm/s TAPE sw-LH-II Note: On X-1000M, adjust both 2T and 4T playback heads.	YTT-1003 (16kHz/-10dB)	Azimuth adj. screw/s of head (Fig. 2-14)	Phase: within 45° on oscilloscope (Fig. 3-3)	
6. Playback level	6-1 Fig. 3-1	PLAY HEAD sw [X-1000M]-2T EQ sw [X-1000M]-NAB OUTPUT cont.-CAL SPEED-19cm/s	YTT-1003 (400Hz/0dB)	R313/R314	-5dB (436mV)	Spec. PB condition For EQ switch location, refer to Fig. 3-6.
	6-2 "	OUTPUT cont.-MAX.	"	Check	+1dB ±2dB (690mV ~ 1.09V)	Max. output level
	6-3 "	OUTPUT cont.-CAL	"	-	-5dB (436mV)	Spec. PB condition IMPORTANT: Do not disturb OUTPUT cont. during later checks.
	6-4 "	PLAY HEAD sw-4T (Reset to 2T afterwards)	"	Check	-9dB ±2dB (218mV ~ 346mV)	X-1000M only
7. VU meter	7-1 Fig. 3-1	Spec. PB condition	YTT-1003 (400Hz/0dB)	Check	0VU ±1VU on VU meter	
8. Frequency response	8-1 Fig. 3-1	TAPE sw -LH-II	38cm/s YTT-1004	R327/R328	40Hz ~ 26kHz ±3dB (Ref.: 400Hz)	X-1000M only
	8-2 "		19cm/s YTT-1003	R333/R334 [X-1000M] R327/R328 [X-1000]	"	
	8-3 "		9.5cm/s YTT-1002	R333/R334	Fig. 3-4	X-1000 only
	8-4 "	TAPE sw -EE	38cm/s YTT-1054	Check	40Hz ~ 26kHz ±3dB (Ref.: 400Hz)	
	8-5 "		19cm/s YTT-1053	"	"	
	8-6 "		9.5cm/s YTT-1052	"	Fig. 3-4	
9. Phase shift	9-1 Fig. 3-2	TAPE sw-LH-II SPEED-38cm/s	YTT-1004	Check	Phase: within 45° on oscilloscope (50Hz ~ 22kHz) (Fig. 3-3)	
	9-2 "	SPEED-19cm/s	YTT-1003	"	(50Hz ~ 18kHz)	
	9-3 "	SPEED-9.5cm/s	YTT-1002	"	(50Hz ~ 10kHz)	
10. PHONES output level	10-1 Fig. 3-5	Spec. PB condition	YTT-1003 (400Hz/0dB)	Check	-24dB ±2dB (38.8mV ~ 61.5mV) (at PHONES jack)	When OUTPUT terminal is at -5dB

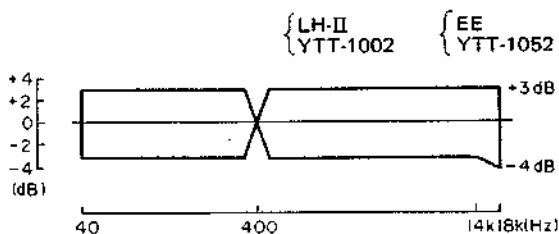

Fig. 3-4 Playback frequency response (9.5cm/s)

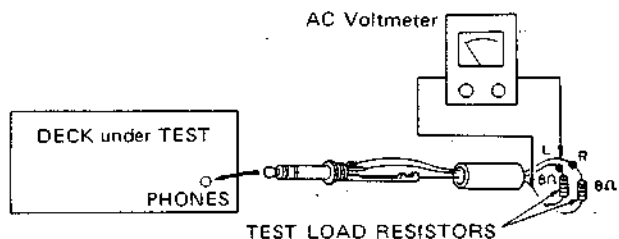

Fig. 3-5 Connection for PHONES level check

X-1000M/X-1000

ITEM	CONNECTION	MODE/ INSTRUCTION	SIGNAL SOURCE	ADJUST (or CHECK)	RESULT	REMARKS
11. Signal to noise ratio	11-1 Fig. 3-1	LH and EE Spec. PB condition Use fully erased tape (Use bulk tape eraser)	YTT-8013 and YTT-8053	Check	LH-I, -II: 38cm/s 50dB 19cm/s 50dB 9.5cm/s 49dB EE: 38cm/s 52dB 19cm/s 52dB 9.5cm/s 52dB	-Ratio of spec. -5dB to noise -Change-over the polarity of the AC Line plug. The worse reading should be within spec.
12. Frequency response (4T play-back head) [X-1000M]	12-1 Fig. 3-1	TAPE sw—LH-II SPEED—19cm/s PLAY HEAD sw—4T (Reset to 2T afterwards)	YTT-1003	Check	50Hz ~ 14kHz ±7dB (Ref.: 400Hz)	
13. Frequency response (IEC) [X-1000M]	13-1 Fig. 3-1	TAPE sw—LH-II SPEED—38cm/s EQ sw—IEC For EQ switch location, refer to Fig. 3-6	YTT-1004	Check	Level difference against measured value in step 8-1 at each frequency point (3) should be as shown approximately: 63Hz 10kHz 20kHz +2.1dB -2.7dB -3.0dB	
	13-2	IMPORTANT: After completion of step 13-1, set EQ sw as below: For USA, Canada, Australia and General Export models — NAB position For Europe and U.K. models — IEC position				

3-3 RECORDING PERFORMANCE

TEAC test tape: YTT-8013: For recording alignment (blank) for LH-II
YTT-8053: For recording alignment (blank) for EE

ITEM	CONNECTION	MODE/ INSTRUCTION	SIGNAL SOURCE	ADJUST (or CHECK)	RESULT	REMARKS		
14. Bias trap	14-1	AC voltmeter between BIAS TRAP TP (TP1/TP2) & GND	—	L303/L304	Min. reading	Bias freq.: 100kHz ±5kHz		
	14-2	Fig. 3-1	Rec-pause mode	Check	Min. reading (-45dB or more (4.36mV or less))			
	14-3	"	"	Check	VU: no deflection			
15. Record head azimuth	15-1 Fig. 3-2	MONITOR—TAPE SPEED—19cm/s	10kHz/-32dB (19.5mV)	Azimuth adj. screw/s of head (Fig. 2-14)	Phase: within 45° on oscilloscope (Fig. 3-3)			
16. Record bias	16-1	Fig. 3-1	19cm/s [X-1000M] or 9.5cm/s [X-1000]	EE YTT-8053	7kHz/-22dB (61.5mV)	R515/R516	Over-bias value 2.5dB ±1dB (3dB ±1dB for X-1000) from peak	-Simultaneous monitoring -First set adjustor fully CCW (⊖), then adjust.
	16-2	"	MONITOR—TAPE	LH-II YTT-8013	"	R519/R520	Over-bias value 3dB ±1dB (4dB ±1dB for X-1000) from peak	

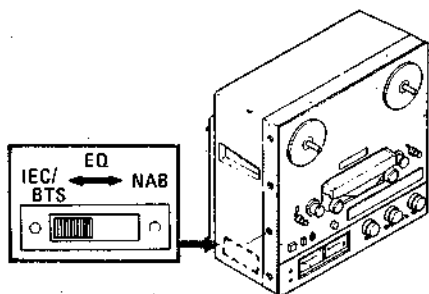

Fig. 3-6 EQ switch location (X-1000M only)

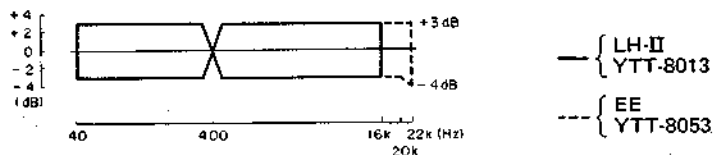

Fig. 3-7 Overall frequency response (9.5cm/s)

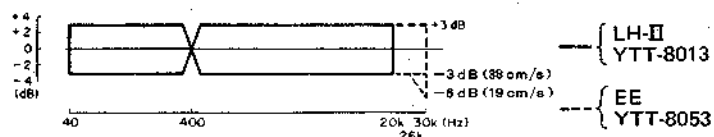

Fig. 3-8 Overall frequency response (38cm/s, 19cm/s)

ITEM	CONNECTION	MODE/ INSTRUCTION	SIGNAL SOURCE	ADJUST (or CHECK)	RESULT	REMARKS	
17. Record level	17-1 Fig. 3-1	Same as 16-2 SPEED—19cm/s	400Hz/—12dB (195mV)	R429/R430	—5dB (436mV)	Spec. REC condition	
18. Distortion	18-1 Fig. 3-1	Same as 16-1 and 16-2, but SPEED sw —38cm/s [X-1000M] or 19cm/s [X-1000]	1kHz/—12dB (195mV)	Check	0.8% or less (w/LH-II, EE)		
19. Signal to noise ratio	19-1 Fig. 3-1	MONITOR—TAPE { LH-II { YTT-8013 { EE { YTT-8053	1kHz/—12dB (195mV) then No signal recording	Check	LH-II: 38cm/s 48dB 19cm/s 48dB 9.5cm/s 46dB EE: 38cm/s 50dB 19cm/s 50dB 9.5cm/s 50dB	Ratio of spec. —5dB to noise	
20. Erase efficiency	20-1 Fig. 3-1 switch on 1kHz filter	TAPE sw—EE MONITOR—TAPE SPEED—38cm/s [X-1000M] or 19cm/s [X-1000] TAPE—YTT-8053	1kHz/—2dB (615mV) (+10VU) then erasing	Check	38cm/s: 65dB min. ratio 19cm/s: 70dB min. ratio	-Ratio of 1kHz portion to "no signal" portion -The worst value should be within spec.	
21. REC MUTE function	21-1 Fig. 3-1 switch on 1kHz filter	Spec. REC condition Rec-mute mode	1kHz/—2dB (615mV) (+10VU) then record muting	Check	65dB min. ratio	-Ratio of 1kHz portion to "no signal" portion -The worst value should be within spec.	
22. Frequency response	22-1 Fig. 3-1	MONITOR —TAPE	9.5cm/s	Required signal/ —32dB (19.5mV)	L305/L306 [X-1000]	Fig. 3-7	Also it is possible to fine-adjust by the record bias adjustors (see item 16.) if this respective specified record bias setting ranges are kept.
	22-2 "	EE YTT-8053	19cm/s	"	Check [X-1000] L305/L306 [X-1000M]	Fig. 3-8	
	22-3 "		38cm/s	"	Check	Fig. 3-8	
	22-4 "	LH-II YTT-8013	9.5cm/s	"	"	Fig. 3-7	
	22-5 "		19cm/s	"	"	Fig. 3-8	
	22-6 "		38cm/s	"	"	Fig. 3-8	
23. Phase shift	23-1 Fig. 3-2	Spec. REC condition SPEED—19cm/s	40Hz ~ 10kHz/ —32dB (19.5mV)	Check	Phase: within 45° on oscilloscope (40Hz ~ 16kHz) (Fig. 3-3)		
24. LH-I position check	24-1 Fig. 3-1	Spec. REC condition Tape—YTT-8013 SPEED—19cm/s	20kHz/—32dB (19.5mV)	Check	When TAPE SELECTOR sw is changed LH-II → LH-I, output level should raise +3dB ±1dB.		
25. Adjacent track crosstalk [X-1000]	25-1 Fig. 3-1	Spec. REC condition SPEED—19cm/s TAPE sw—LH-II	125Hz/—12dB (195mV)	—	—		
	25-2 "	Interchange R & L reels then play.	—	Check	At both L-and R-ch 125Hz: —45dB or more (4.36mV or less) (40dB min. ratio)		
26. Channel separation	26-1 Fig. 3-1 switch on 1kHz filter	Same as 25-1	L: 1kHz/—12dB (195mV) R: No signal record.	Check	R, —55dB or more (1.38mV or less) (50dB min. ratio)		
	26-2 "	"	L: No signal record. R: 1kHz/—12dB	"	L, "		

3-4 DBX PERFORMANCE

NOTE:

Test this performance only after you are sure that the "3-5 DBX PCB ADJUSTMENT is correct.

ITEM	CONNECTION	MODE/ INSTRUCTION	SIGNAL SOURCE	ADJUST (or CHECK)	RESULT	REMARKS	
27. Encoder level	27-1	OSC → ATT to LINE IN (both L- & R-ch's) AC voltmeter to REC AND PLAY AMPL. PCB term. #46	DBX sw—OUT MONITOR—SOURCE OUTPUT cont.—CAL LINE cont.—Spec. position (item 1-2) MIC cont.—MIN	1kHz/−12dB (195mV)	Check	−8dB (308mV)	
	27-2	"	Same as above, but DBX sw—IN	"	R737/R738	−8dB ±0.5dB (291mV ~ 327mV)	
	27-3	Repeat 27-1 ~ 27-2 by changing to REC AND PLAY AMPL. PCB term. #47. IMPORTANT: Do not disturb all MIC, LINE and OUTPUT controls during later checks.					
28. Decoder level	28-1	Fig. 3-1	Tape—YTT-8013 DBX sw—OUT SPEED—19cm/s REC MODE—ON TAPE sw—LH-II MONITOR—TAPE	1kHz/−12dB (195mV)	Check	Note the measured output as reference.	
	28-2	"	Same as above but DBX sw—IN	"	R637/R638	±0.5dB deviation from ref.	
29. Frequency response	29-1	Fig. 3-1	Same as 22-1 ~ 22-6, but DBX sw—IN EE YTT-8053 } only	Required signal, −32dB (19.5mV)	Check	38cm/s, 19cm/s: 40Hz ~ 20kHz +5, −4dB (Ref.: 400Hz) 9.5cm/s: 40Hz ~ 16kHz +5, −4dB (Ref.: 400Hz)	
30. Signal to noise ratio	30-1	Fig. 3-1	DBX sw—IN REC MODE sw—ON MONITOR—TAPE {LH-II {YTT-8013 {EE {YTT-8053	1kHz/−12dB (195mV) then No signal recording	Check	65dB min. ratio (w/LH-II, EE at all tape speeds)	Ratio of spec. −5dB to noise
31. Distortion	31-1	Fig. 3-1	Same as 30-1 but SPEED—38cm/s [X-1000M] or 19cm/s [X-1000]	1kHz/−12dB (195mV)	Check	0.8% or less (w/LH-II, EE)	0VU input level
	31-2	"	"	1kHz/+8dB (1.95V)	"	3% or less (w/LH-II, EE)	20VU input level

3-5 DBX PCB ADJUSTMENT

NOTES:

1. This section adjustment is not usually needed unless a trimmer(s) has been changed or a component(s) on the DBX PCB has sustained damage, since the PCB has been precisely adjusted in the factory.
2. Disconnect all connectors on the DBX PCB, except for J501/P501. Turn the deck OFF to prevent accidental damage when disconnecting or reconnecting.

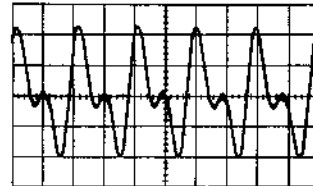

Fig. 3-9 RMS symmetry adjustment (incorrect)

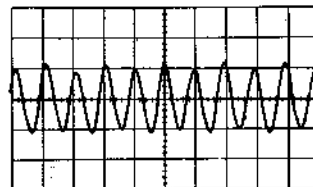

Fig. 3-10 RMS symmetry adjustment (correct)

3-5-1 ENCODER ADJUSTMENT

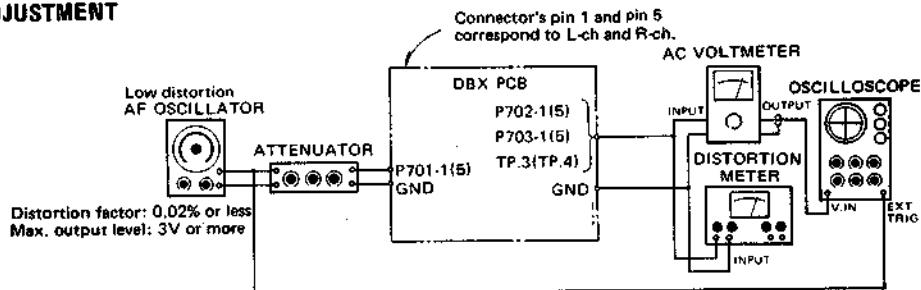

Fig. 3-11 Encoder adjustment setup

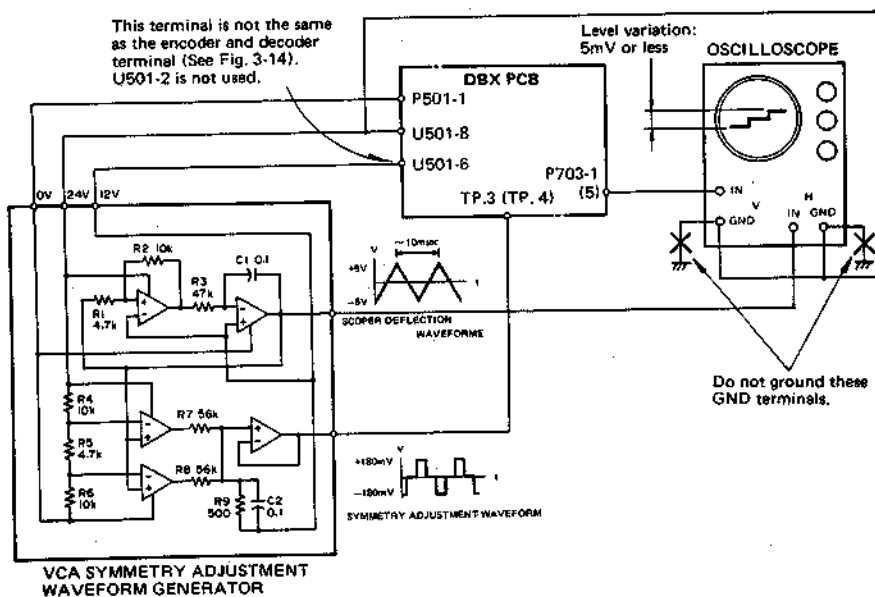

Fig. 3-12 VCA symmetry adjustment setup (encoder)

ITEM	STEP	INPUT INSTRUCTION	ADJUST (or CHECK)	MEASURING POINT: RESULT	REMARKS
1. Preparation	1	Prepare test setup as shown on Fig. 3-11.			
	2	Preset each of the trimmers of the encoder section on the PCB to their approximate center positions.			
2. Input setting	3	Apply 100Hz level to get RESULT value.	Attenuator	P702-1(5): 300mV (-8.2dB)	
3. RMS symmetry	4		R765/R766	TP3(TP4): Clean 200Hz sine-wave	Refer to Figs. 3-9 and 3-10.
4. RMS time constant	5		Check	TP3(TP4): 385μV (-66.1dB) ±20%	
5. Encoder nominal level	6	Apply 1kHz level to get RESULT value.	Attenuator	P702-1(5): 300mV (-8.2dB)	
	7		R737/R738	P703-1(5): 300mV (-8.2dB)*1	*1 Reference 1
6. VCA symmetry	8	Change test setup to as Fig. 3-12, then adjust.	R757/R758	P703-1(5): A relatively straight horizontal line on the 'scope face'. (Level variation: 5mV or less)	

ITEM	STEP	INPUT INSTRUCTION	ADJUST (or CHECK)	MEASURING POINT: RESULT	REMARKS
7. Frequency response (X-1000M)	9	Return to Fig.3-11 test setup. Change oscillator frequency to 100Hz.	Check	P703-1(5): -2.5dB \pm 0.5dB against Ref. 1. (212mV ~ 238mV)	
	10	Change oscillator frequency to 10kHz.	Check	P703-1(5): -4.7dB \pm 0.5dB against Ref. 1. (165mV ~ 185mV)	
8. Frequency response (X-1000)	11	Change oscillator frequency to 100Hz.	Check	P703-1(5): +0.5dB \pm 0.5dB against Ref. 1. (300mV ~ 337mV)	
	12	Change oscillator frequency to 10kHz.	Check	P703-1(5): -3.2dB \pm 0.5dB against Ref. 1. (196mV ~ 220mV)	
9. Encoder effect-1	13	Apply 1kHz level*2 to get RESULT value.	Attenuator	P702-1(5): 300mV (-8.2dB)	*2 Reference 2
	14	Apply 1kHz at -60dB against Ref. 2.	Check	P703-1(5): -30dB \pm 0.5dB against Ref. 1. (8.96mV ~ 10.1mV)	
10. Encoder effect-2	15	Apply 1kHz at +20dB against Ref. 2.	Check	P703-1(5): +10dB \pm 0.5dB against Ref. 1. (0.896V ~ 1.01V) Distortion: 0.3% or less	

3-5-2 DECODER ADJUSTMENT

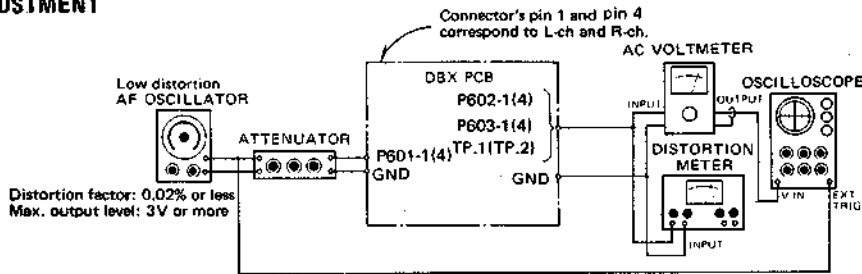

Fig. 3-13 Decoder adjustment setup

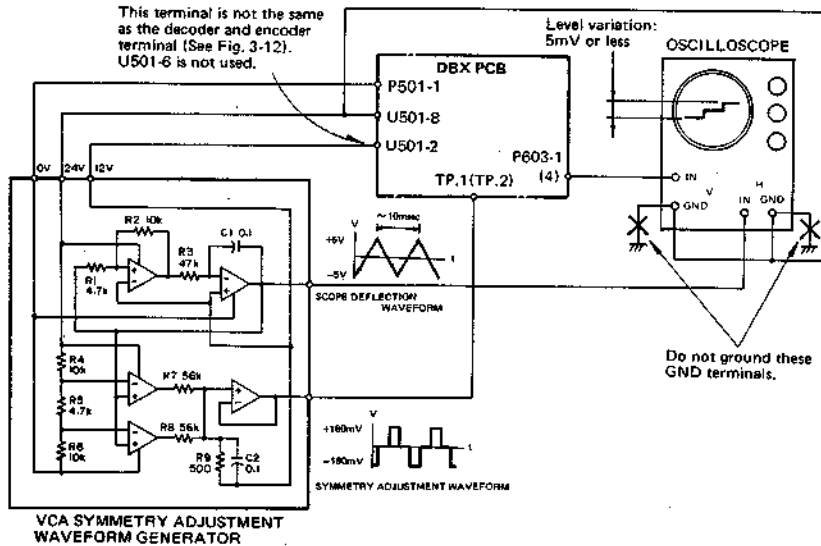

Fig. 3-14 VCA symmetry adjustment setup (decoder)

ITEM	STEP	INPUT INSTRUCTION	ADJUST (or CHECK)	MEASURING POINT:	
				RESULT	REMARKS
1. Preparation	1	Prepare test setup as shown on Fig. 3-13.			
	2	Preset each of the trimmers of the decoder section on the PCB to their approximate center positions.			
2. Input setting	3	Apply 100Hz level to get RESULT value.	Attenuator	P602-1(4): 300mV (-8.2dB)	
3. RMS symmetry	4		R665/R666	TP1(TP2): Clean 200Hz sine-wave	Refer to Figs. 3-9 and 3-10.
4. RMS time constant	5		Check	TP1(TP2): 385μV (-66.1dB) ±20%	
5. Decoder nominal level	6	Apply 1kHz level to get RESULT value.	Attenuator	P602-1(4): 300mV (-8.2dB)	
	7		R637/R638	P603-1(4): 300mV (-8.2dB) *1	*1 Reference 1
6. VCA symmetry	8	Change test setup to as Fig. 3-14 then adjust.	R657/R658	P603-1(4): A relatively straight horizontal line on the 'scope face'. (Level variation: 5mV or less)	
7. Frequency response (X-1000M)	9	Return to Fig. 3-13 test setup. Change oscillator frequency to 100Hz.	Check	P603-1(4): +5dB ±1dB against Ref. 1. (476mV ~ 599mV)	
	10	Change oscillator frequency to 10kHz.	Check	P603-1(4): +9.4dB ±1dB against Ref. 1. (789mV ~ 994mV)	
8. Frequency response (X-1000)	11	Change oscillator frequency to 100Hz.	Check	P603-1(4): -0.3dB ±1dB against Ref. 1. (258mV ~ 325mV)	
	12	Change oscillator frequency to 10kHz.	Check	P603-1(4): +3.2dB ±1dB against Ref. 1. (387mV ~ 487mV)	
9. Decoder effect-1	13	Apply 1kHz level *2 to get RESULT value.	Attenuator	P602-1(4): 300mV (-8.2dB)	*2 Reference 2
	14	Apply 1kHz at -30dB against Ref. 2.	Check	P603-1(4): -60dB ±1dB against Ref. 1. (267μV ~ 337μV)	
10. Decoder effect-2	15	Apply 1kHz at +10dB against Ref. 2.	Check	P603-1(4): +20dB ±1dB against Ref. 1. (2.67V ~ 3.37V) Distortion: 0.2% or less	

3-6 ADJUSTMENT AND TEST POINT LOCATIONS

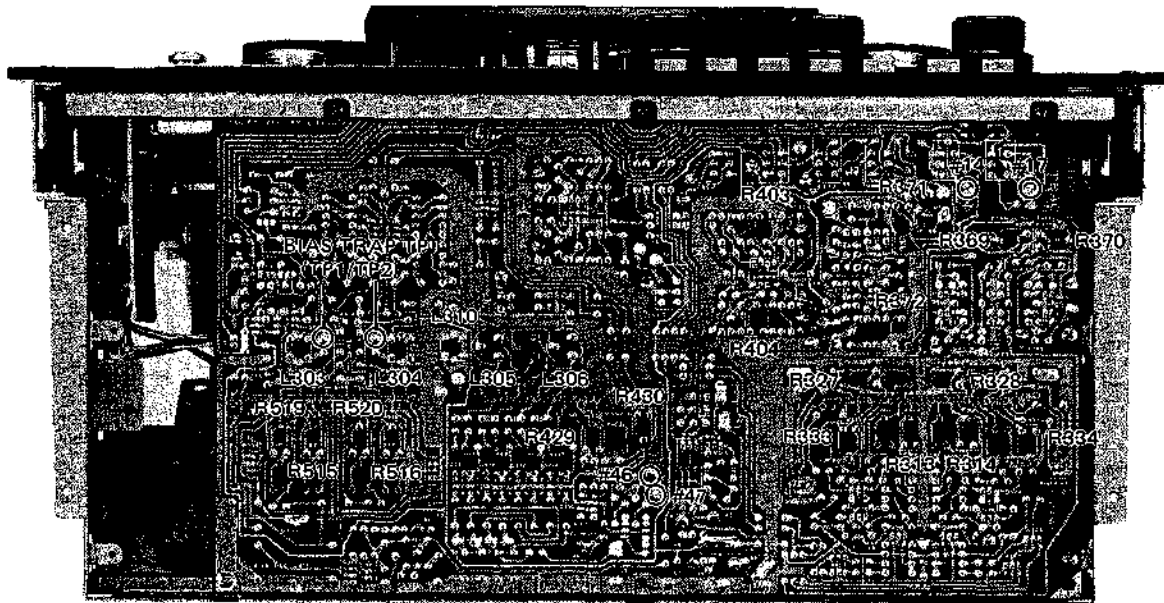

Fig. 3-15 REC AND PLAY AMP PCB

L303/L304	Bias trap (record)
L305/L306	Record EQ
L310	Dummy Coil
R313/R314	Playback level
R327/R328	Playback EQ (HIGH)
R333/R334	Playback EQ (LOW)

R369/R370	Monitor level
R371/R372	VU meter
R403/R404	Output level
R429/R430	Record level
R515/R516	Record bias (EE)
R519/R520	Record bias (LH □)

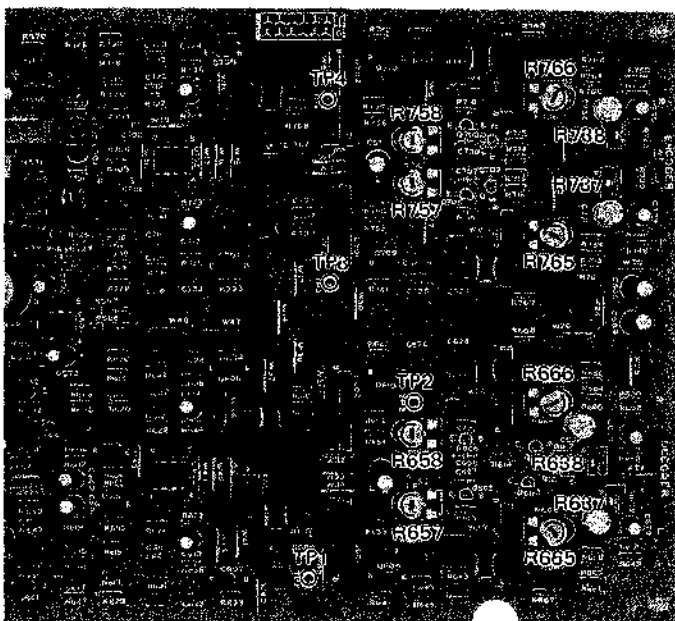

Fig. 3-16 DBX PCB

R637/R638	Nominal level (DECODER)
R657/R658	VCA symmetry (DECODER)
R665/R666	RMS symmetry (DECODER)
R737/R738	Nominal level (ENCODER)
R757/R758	VCA symmetry (ENCODER)
R765/R766	RMS symmetry (ENCODER)

- 注意 1. プリント基板図はパターン面が示されています。
2. *印の部品は納期が若干かかります，あらかじめご了承ください。
3. Δ印は安全規格重要部品です，交換するときは必ずティアック指定の部品を使用して下さい。

※ dbxおよびdbxマークはdbxインコーポレーテッドの登録商標です。
※ dbxシステムはdbxインコーポレーテッドの実施権に基づいて製造されています。

機構部の調整

番号	調整項目	サービスデータ				備考	
			正方向	負方向	左右差		
1	ブレーキトルク	右 リール	1.2~1.9	(0.7)	0.2以内	単位 kg・cm (トルク)は参考値 ブレーキ位置調整方法 1項参照	
		左 リール	1.2~1.9	(0.7)			
2	ピンチローラポーズ位置	ポーズ時の、キャプスタンとピンチローラ間のすき間 0.5~1mm				調整方法 2項参照	
3	ピンチローラ圧着ストローク	プレイ時、ピンチローラアームストップピンと、ストップラバーのすき間約1mm (左・右いずれか一方にのみすき間を生ずるので、すき間のある側を調整)				調整方法 3項参照	
4	ピンチローラ圧着力	左 右 共 1.35kg~1.9kg				引張法による 無調整・参考値	
5	テープ・テンション	モード	PLAY	FF	REW	テンテロ・メータ使用 単位 g 調整方法 4項参照	
		テンション					
		ティックアップ側	50±10	110±10	110±10		
		サブライ側	50±10	-	-		
6	テープ・スピード	PLAY	テープ速度偏差	3,000Hz±30Hz		調整方法 5項参照	
			テープ速度変動幅	15Hz以内			
			ピッチ・コントロール可変範囲	3,000Hz±180Hz以上		無調整・参考値	
		FF, REW	-	-	仕様・調整方法 5項参照		
7	リール台高さ	RE-702を使用し、テープガリールのフランジに触れないこと。				調整は、テンション・アーム高さ の調整後に行なうこと。	
8	各回転体の スラスト・クリアランス・チェック	キャプスタン・シャフト ガイド・ローラ テンションアームガイドローラ リールモータ 左・右テンションアーム	0.1~0.25mm(マグネット式) 0.05~0.3mm 0.05~0.3mm 0 (スプリング式) 0 (スプリング式)		無調整・参考値 キャプスタン・シャフトはマグネ フロードタイプのため、定常回転中 はスラスト受け方向(デッキ後面 方向)に押されている事を確認す ること。		
9	ワウ・フラック	再生法			録再法	単位 % 7号リール使用時の巻始め及び巻 終りを測定。	
		テープ速度	RMS	WRMS	RMS		
		38cm/s	0.08	0.04	0.10		
	19cm/s	0.10	0.05	0.12			
10	早巻き時間	F.F, REW共 YTT-8013 (550m) にて			60秒以内	無調整・参考値	
11	タイム起動時間					2~6秒	無調整・参考値
12	ヘッド調整とテープ走行系調整	7項参照					

調整方法・調整個所

機構部の調整・チェックには次の機器が必要です。

測定器

1. テンテロ・メータ……テープ・テンション測定
・米国 テンテル社製
MODEL T2-H20-1 (0~600g)
又は T2-H15-UM(0~450g)
2. バネばかり……ピンチ・ローラ圧着力、ブレーキ・トルク測定
3. ワウ・フラッタ・メータ……ワウ・フラッタ、テープ速度測定・周波数カウンタ付
4. 周波数カウンタ……テープ速度測定
5. オシロスコープ……テープ早送りスピード測定

テープ

1. ワウ・フラッタ、テープ・スピード測定用
YTT-2004……38cm/sec
YTT-2003……19cm/sec
2. テープ・テンションその他の測定用
YTT-8013 又は同等品

1. ブレーキ調整

- (1) ブレーキがかかった状態(ブレーキ・ソレノイドOFF)で、ブレーキ・アームのスキマAとスキマBとが等しくなる(ブレーキ・アーム上縁が水平になる)ように、Cの取付け位置を調整する。
- (2) 次に、ブレーキ・ソレノイドをON・OFFしたときのプランジャのストロークが約2mmになるように、ブレーキ・ソレノイドの取付け位置を調整する。
- (3) ブレーキ・ソレノイドON状態の時、ブレーキ・ドラムとブレーキ・フェルトとが接触しないように、ブレーキ・バンド受けの取付け位置を調整する。
- (4) 調整後、すべてのテープ操作に於て、テンション落ち、テープ巻込み等が生じないことを確認する。



図1 ブレーキ調整

2. ピンチ・ローラ・ポーズ位置調整

デッキをポーズ状態にし、ポーズ位置調整ナットにより、キャプスタンとピンチローラ間のすき間を0.5~1.0mmに調整する。キャプスタンとピンチローラのすき間は、左右で差を生ずるが、調整はすき間の少ない側のみ行なう。調整後PLAY→PAUSE、STOP→PAUSEを何回も行ない、すき間を確認すること。

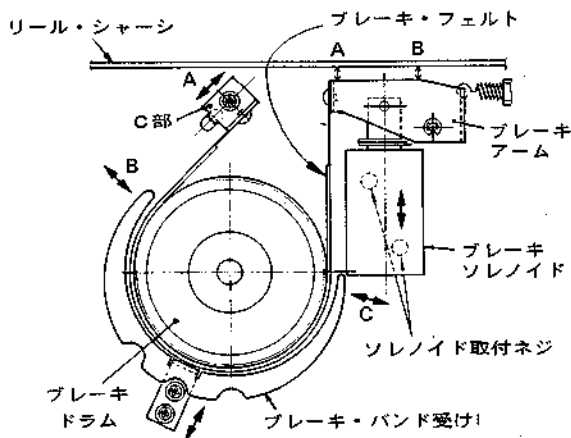

図2 ポーズ位置及び圧着ストローク調整個所

3. ピンチローラ圧着ストローク調整

調整時のデッキの作動モード……PLAY

図2に示す圧着ストローク調整ナットにより、図3に示すようにピンとストップラバーのすき間を約1mmに調整する(ピンとストップラバーが離れていて、すき間が確認出来れば良い)。

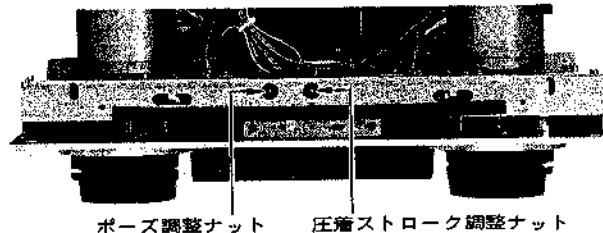
このすき間は、圧着スプリングのバラツキにより、左右いずれか一方にしか出来ないが、すき間の出来た側のみ調整すれば良い。



図3 ピンチ・ローラ圧着調整

4. テープ・テンション調整

テープ・テンション調整は、デッキの電源ON後5～10分以上経過してから行ってください。

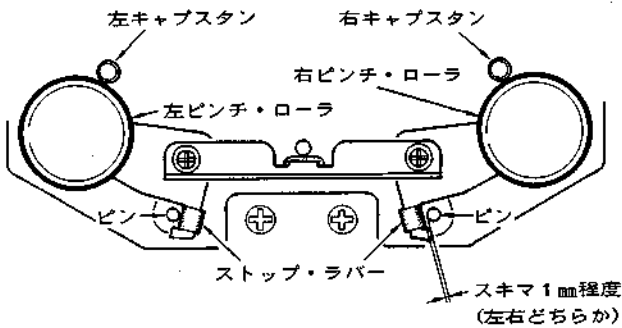

図4 テープ・テンション測定位置

PLAYテンション調整

- (1) テープ(7号リール, 10号リールどちらでもよい)をかけ、左右同程度の巻径にする。
- (2) テープをLOW SPEED(19cm/sec)、FWD PLAYモードで走行させる。
- (3) Aの位置にテンテロ・メータを当て、R120をまわしてテンションを $50g \pm 10g$ (できるだけ50gに近い値)に調整する。

FFテンション調整

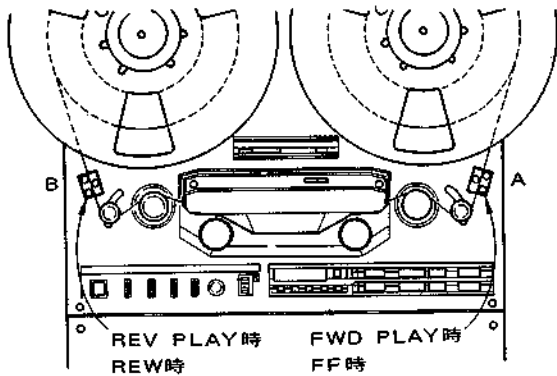
- (1) サプライ側のリール(左リール)を固定してFFモードにする(テープを走行させない状態に保つ)。
- (2) Aの位置にテンテロ・メータを当て、R237をまわしてテンションを $110g \pm 10g$ (できるだけ110gに近い値)に調整する。

参考：FF(REW)時のサプライ側テープ・テンション(バック・テンション)は、次ページに述べるFF(REW)テープ・スピード調整により自動的にセットされます。

REWテンション調整

- (1) サプライ側のリール(右リール)を固定してREWモードにする(テープを走行させない状態に保つ)。
- (2) Bの位置にテンテロ・メータを当て、R238をまわしてテンションを $110g \pm 10g$ (できるだけ110gに近い値)に調整する。

注：FFとREWのテンションはできるかぎり等しくする。



図5 テープ・テンション調整箇所

5. テープ・スピード調整

PLAYスピード

調整箇所 図6参照

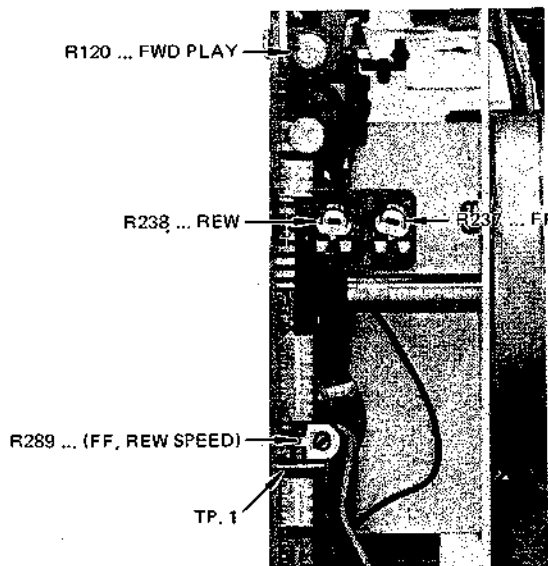
テープ・スピード調整時は、ピッチ・コントロール・スイッチをOFFにしておくこと。



図6 PLAYスピード調整箇所

FF/REWスピード

- (1) パワー/サーボ基板のTP.1(図5参照)にオシロスコープを接続する。
- (2) デッキをFFモード又はREWモードにする。
- (3) TP.1の波形の波長が7 m secになるようにR289(図5参照)を調整する……………図7
- (4) FFとREWで大きな差がないことを確認する。

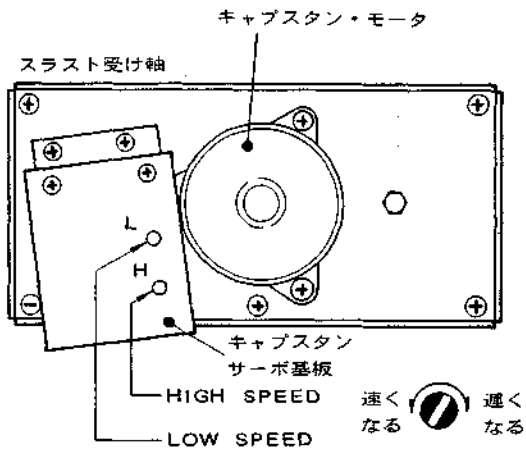

図7 TP.1の波形

6. NAB-BTSイコライザの切換

本機のイコライゼーションは“NAB規格” $3180\mu\text{s} + 50\mu\text{s}$ (38cm/s, 19cm/s 共)で定数設定されていますが、“BTS規格” $3180\mu\text{s} + 35\mu\text{s}$ (38cm/s), $3180\mu\text{s} + 50\mu\text{s}$ (19cm/s)に定数変更する場合は下記の手順で行います。(但し、このEQスイッチはTAPE SELECTORスイッチがLH-I又はLH-IIのみ有効です)

- (1) 本製ケースを外す。
- (2) ボンネットを外す。
- (3) EQスイッチをIEC/BTS側にセットする。
- (4) ボンネットと本製ケースを元に戻す。

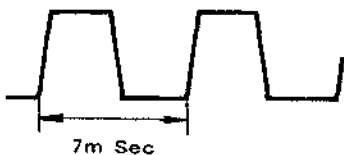

図8 NAB-BTSイコライザの切換

7. ヘッド調整とテープ走行調整

調整の前に、ピンチ・ローラ、キャプスタン・シャフト、ヘッド及びテープ・ガイドをクリーナ液で十分に清掃して下さい。

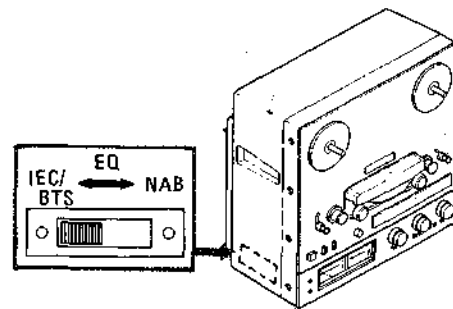
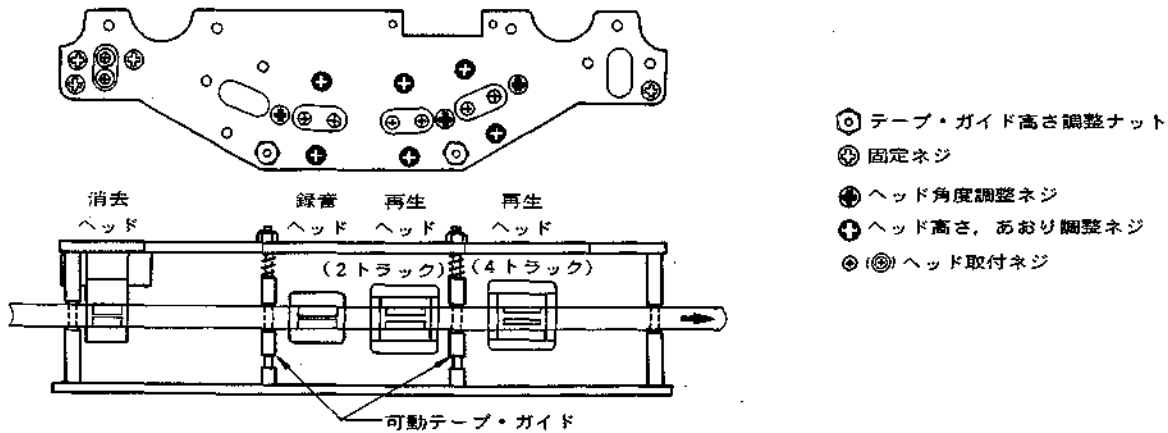

- ⊗ テープ・ガイド高さ調整ナット
- ⊕ 固定ネジ
- ⊙ ヘッド角度調整ネジ
- ⊕ ヘッド高さ、あおり調整ネジ
- ⊗(⊕) ヘッド取付ネジ

図9 テープ・ガイド及びヘッドの配列

7-1. ピンチ・ローラ平行度の仮調整

ピンチ・ローラとキャプスタン・シャフトとの平行度は、テープ走行の安定に最も重要な事項です。以下に左ピンチ・ローラの平行度調整の手順を述べますが、右ピンチ・ローラについても同様に調整して下さい。

- 図10に示すテープ・リフタを手で押し上げ、ピンチ・ローラをキャプスタン・シャフトに近づける。
- 図10に示すA方向から見て、ピンチ・ローラとキャプスタン・シャフトの平行度をチェックする。(図11)
- 平行でない場合は、調整棒を使用して図13に示すA又はA'方向にピンチ・ローラ軸の傾きを修正する。(調整棒は出来るだけピンチ・ローラ軸に近い位置にセットして下さい。)
- 次にピンチ・ローラを外し、テープ・リフタを上げ、図10のB方向から見てピンチ・ローラとキャプスタン・シャフトの平行度をチェックする。



図10 平行度のチェック方向



図11 A視図(平行でない例)

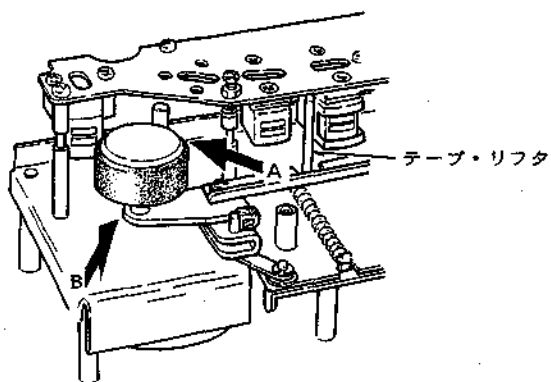

図12 B視図(平行でない例)

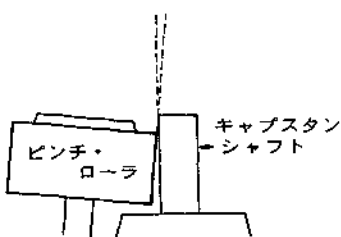

図13 ピンチ・ローラ軸傾きの修正

7-2. ヘッドのあおり仮調整

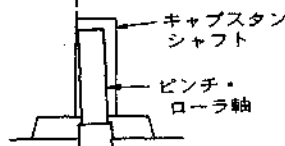
各録音ヘッド，再生ヘッドのあおりを仮調整します。
(本調整はアンプ部の調整時に行なって下さい。)

- 再生ヘッドは、ヘッド前面と可変テープ・ガイドのテープ走行部とが平行になるよう調整。(図14)
- 録音ヘッドは、ヘッド前面とキャプスタン・シャフトとが平行になるよう調整。(図15)

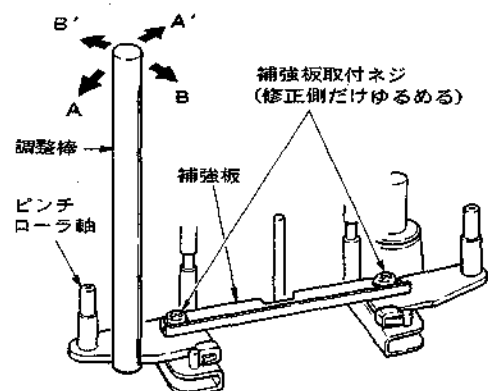

図14 再生ヘッドのあおり調整



図15 録音ヘッドのあおり調整

7-3. テープ・ガイドの高さ調整

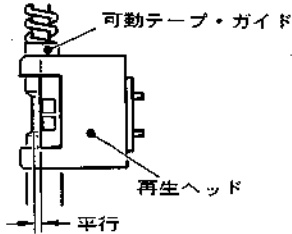
テープをPLAY状態で走行させながら、各テープ・ガイドでテープがカールしないように調整します。

- 消去ヘッド外側のテープ・ガイドの下側にテープがカールしない程度に軽く接触するようテンション・アームの高さを調整する。(図16)
- 可動テープ・ガイドは、ガイド上側にテープがカールしない程度に軽く接触するよう高さを調整する。(図17) (調整後ネジ・ロック塗付のこと)。

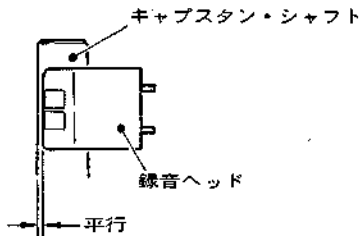

図16 テンション・アーム高さ調整



図17 可動テープ・ガイド高さ調整

7-4. ピンチ・ローラ平行度微調整

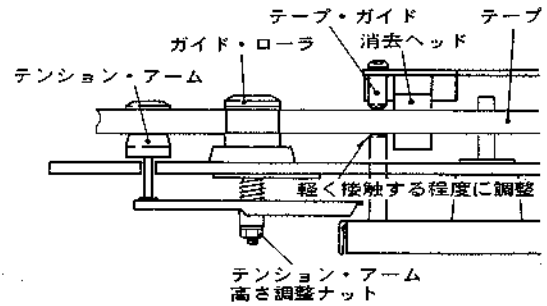
テープ速度をHIGHにし、PLAY状態でチェックして下さい。

- ピンチ・ローラ・キャップを外す。
- ピンチ・ローラを1～2mm引き抜き、デッキをプレイ状態にする。
- プレイ中、ピンチ・ローラの位置が軸方向に移動するかどうかチェックする。
- 移動する場合は、図13の方法でピンチ・ローラ軸の傾きを微調整する。

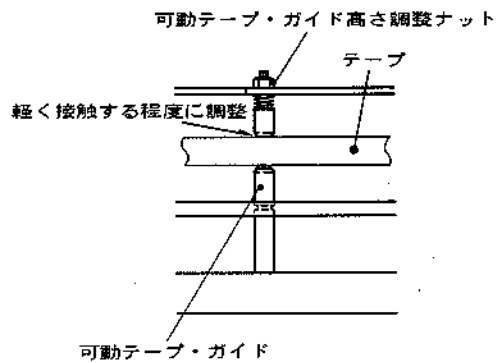
アンプ部の調整箇所



図 18 録・再基板調整箇所

L 303 / L 304	バイアス・トラップ	R 369 / R 370	モニタ・レベル
L 305 / L 306	録音イコライザ	R 371 / R 372	VUメータ
R 313 / R 314	再生レベル	R 403 / R 404	出力レベル
R 327 / R 328	再生イコライザHIGH	R 429 / R 430	録音レベル
R 333 / R 334	再生イコライザLOW	R 515 / R 516	録音バイアスEE
L 310	ダミーコイル	R 519 / R 520	録音バイアスLH II

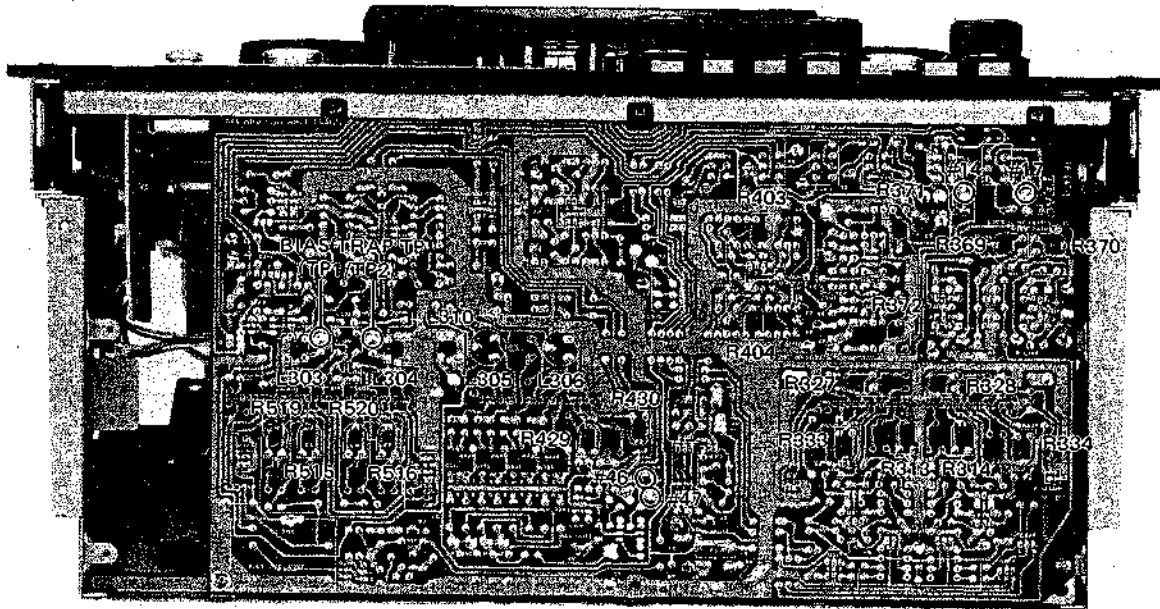

図 19 DBX基板調整箇所

アンプ部の調整

モニタ系 (DBXスイッチ: OUT)

0dB=0.775V

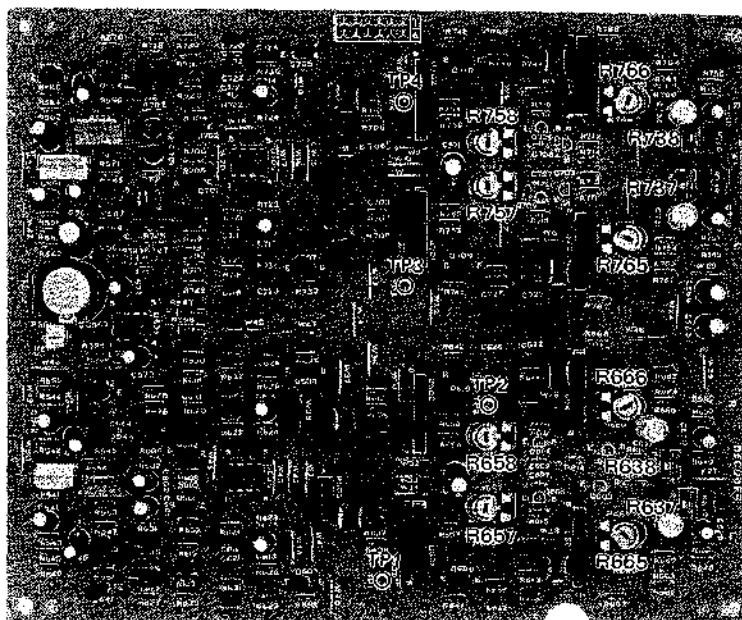
調整項目	準備・設定	入力信号	調整箇所	測定箇所・調整値	備考
1. モニタレベルセット	1-1 MONITORスイッチSOURCE OUTPUT つまみ CAL LINE つまみ 最大 MIC つまみ 最小	LINE IN -22dB/400Hz	R369(Lch)	REC AND PLAY AMPL PCB#14 -8dB	LINE IN (Lch) 最大感度
	1-2 同上	LINE IN -12dB/400Hz	LINEつまみ(L/R)	同上 -8dB	LINE 規定入力 (L)
	1-3 LINE 規定入力状態	同上	R370(Rch)	同上 PCB#17 -8dB	LINE 規定入力 (R)
2. モニタ出力レベルセット	2-1 同上	同上	R403/R404	OUTPUT -5dB	
3. モニタVUMETERレベルセット	3-1 同上	同上	R371/R372	VUMETER 0VU	
4. MICレベルセット	4-1 LINE つまみ 最小 MIC つまみ 最大	MIC -70dB/400Hz	チェック	OUTPUT -7dB~-3dB	MIC最大感度
	4-2 同上	MIC -60dB/400Hz	MIC つまみ	OUTPUT -5dB	MIC規定入力

再生系 (特に指示のない時はTAPE SELECTORスイッチはLH-II, PLAYBACK HEADスイッチは2T)

0dB=0.775V

調整項目	準備・設定	入力信号	調整箇所	測定箇所・調整値	備考
5. 再生レベルセット	5-1 MONITORスイッチ TAPE OUTPUT つまみ CAL テープスピード LOW モード PLAY	YTT-1003 (400Hz/0dB)	R313/R314	OUTPUT -5dB	規定再生状態
	5-2 OUTPUT つまみ 最大	YTT-1004 (400Hz/0dB)	チェック	OUTPUT -1dB~+3dB	最大出力レベル
	5-3 OUTPUT つまみ CAL	YTT-1003 (400Hz/0dB)	-	OUTPUT -5dB	規定再生状態
6. VU計レベルセット	6-1 規定再生状態	YTT-1003 (400Hz/0dB)	チェック	VUMETER 0VU±1VU	
7. 4Tヘッドレベル	7-1 規定再生状態 モード PLAY	規定再生状態 モード PLAY	チェック	OUTPUT -9dB±2dB	PLAYBACKスイッチ
8. 再生周波数特性	8-1 38cm/s PLAY	YTT-1004 (LH II)	R327/R328	40~26k Hz ±3dB	400Hzを 0dBとする。
	8-2 19cm/s PLAY	YTT-1003 (LH II)	R333/R334	40~26k Hz ±3dB	
	8-3 38cm/s PLAY	YTT-1004 (EE)	チェック	OUTPUT: TAPE SELECTOR スイッチをEEに切替えた時20k Hzのレベルの下降 3dB±1dB	
	8-4 19cm/s PLAY	YTT-1003 (EE)	チェック		
	8-5 PLAYBACK HEAD 4T 19cm/s PLAY	YTT-1003 (LH II)	チェック	50~14k Hz ±7dB	
9. 再生位相ずれ	9-1 38cm/s PLAY	YTT-1004 (LH II)	チェック	50~22k Hz 45°以内	
	9-2 19cm/s PLAY	YTT-1003 (LH II)	チェック	50~18k Hz 45°以内	
10. ヘッドホン出力	10-1 規定再生状態 PHONES ジャックに8Ω のダミー抵抗を接続	YTT-1003 (400Hz/0dB)	チェック	抵抗両端 -24dB±2dB	OUTPUT -5dBの時
11. 再生S・N比	11-1 規定再生状態 生テープ又はバルク・イ レーサで十分に消磁した テープ	YTT-8013 (LH II) YTT-8053 (EE)	チェック	LH II 50dB以上 EE 52dB以上	電源極性の影響 については悪い 方の値が規格を 満足すること。 (基準-5dB)



図20 録再周波数特性 (38 cm/s, 19 cm/s)

録音系

(特に指示のない時はTAPE SELECTORスイッチはLH-II, PLAYBACK HEADは2T)

0dB=0.775V

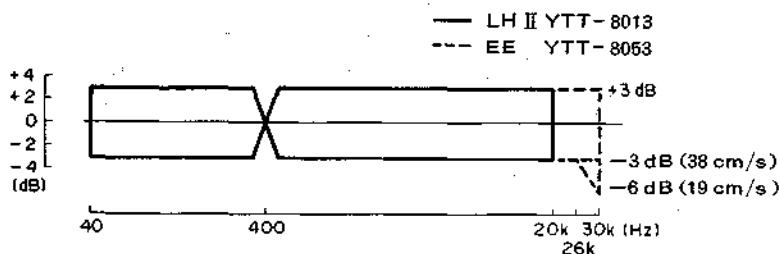
調整項目	準備・設定	入力信号	調整箇所	測定箇所・調整値	備考	
12. バイアストラップ調整	12-1	モード REC/PAUSE	L303/L304	TP1又はTP2 - GND間 バイアス漏れ 最小	バイアス周波数 100kHz±5kHz	
	12-2	モード REC/PAUSE MONITOR スイッチ TAPE OUTPUT つまみ CAL	チェック	OUTPUT バイアス漏れ -45dB以下		
	12-3	同上	チェック	VU計 振れないこと		
13. BIASセット	13-1	テストテープ YTT-8053 YTT-8013 テープスピード 19cm/S MONITOR スイッチ TAPE LINE つまみ 規定位置	LINE IN -22dB/7kHz EE R515/R516 LH II R519/R520	同時モニタ OUTPUT オーバーバイアス値 2.5dB±1dB (EE) 3dB±1dB (LH II)		
14. 録音レベルセット	14-1	同上 テストテープ YTT-8013 テープスピード 19cm/s	LINE IN -12dB/400Hz R429/R430	OUTPUT -5dB	規定録音状態	
15. 歪み率チェック	15-1	規定録音状態	LINE IN -12dB/1kHz	OUTPUT 0.8%以下	EE, LH II共	
16. 総合S・N比	16-1	規定録音状態 テープスピード 38cm/s 19cm/s	無信号	OUTPUT LH II 48dB以上 EE 50dB以上	基準レベルは -5dB	
17. 消去率	17-1	規定録音状態 テープスピード 19cm/s テープ YTT-8053	LINE IN -2dB/1kHz (+10VU) 録音後消去	EE チェック	OUTPUT (消去率 65dB以上) 1kHz BPF使用	
18. REC MUTE効果	18-1	規定録音状態 モード REC/MUTE	LINE IN -2dB/1kHz (+10VU)	チェック	OUTPUT -60dB以下 (MUTE効果 65dB以上)	
19. 総合周波数特性	19-1	規定録音状態 テープスピード 19cm/s	LINE IN -32dB/40~30k Hz	L305/L306	OUTPUT 図20	YTT-8053 (EE) で調整400Hzを 0dBとする。 バイアス微調可
	19-2	規定録音状態 テープスピード 38cm/s	LINE IN -32dB/40~30k Hz	チェック	OUTPUT 図20	
20. 総合位相ずれ	20-1	規定録音状態 テープスピード 19cm/s	LINE IN -32dB/40~10k Hz	チェック	OUTPUT 40~10k Hz 45°以内	
21. LH Iの確認	21-1	規定録音状態 テープスピード YTT-8013 テープスピード 19cm/s	LINE IN -32dB/20k Hz	チェック	OUTPUT TAPE SELECTOR スイッ チをLHII→LHIにした時 の出力レベル上昇。 3dB±1dB	
22. セパレーション (FWD REC)	22-1	規定録音状態 テストテープ YTT-8013 テープスピード 19cm/s TAPE SELECTORスイッチLHIII モード REC	LINE IN L -12dB/1kHz R無信号	チェック	OUTPUT Rch (出力レベル) -55dB以下	(1kHz BPF)
	22-2	同上	LINE IN L無信号 R -12dB/1kHz	チェック	OUTPUT Lch (出力レベル) -55dB以下	(1kHz BPF)

DBX系

注. DBXのレベル調整はDBXユニットの調整を完了してから行うこと.

0dB=0.775V

調整項目	準備・設定	入力信号	調整箇所	測定箇所・調整値	備考
26. エンコーダ・レベルセット	26-1 1-3項の状態 DBXスイッチをINにする	LINE IN -12dB/1k Hz	R737/R738	REC AND PLAY AMPL PCB #46 (47) -8dB±0.5dB	
27. デコーダ・レベルセット	27-1 14-1項の状態 DBXスイッチをINにする	LINE IN -12dB/1k Hz	R637/R638	OUTPUT IN-OUTのレベル差0.5dB	
28. DBX IN-OUT切替時の 録再レベル差	28-1 14-1項の状態 DBXスイッチをIN-OUT する	LINE IN -12dB/400Hz	チェック	OUTPUTのレベル差 2dB以内	
29. DBX録再周波数特性 (単一スイープ応答)	29-1 19-1, 19-2項の状態 DBXスイッチをINにする	LINE IN -12dB (38cm/s) -22dB (19cm/s)	チェック	OUTPUT 40~20k Hz ±5dB -4dB	EE: YTT-8053
30. DBX総合S.N比	30-1 16-1項の状態 DBXスイッチをINにする	無信号	チェック	OUTPUT 65dB以上	
31. DBX歪み率チェック	31-1 15-1項の状態 DBXスイッチをINにする	LINE IN -12dB/1k Hz +8dB/1k Hz	チェック	OUTPUT 0.8%以下(0VU) 3%以下(+20VU)	

DBXユニットの調整

注1. DBXユニットは通常、調整の必要はありません。万一、調整する場合は次の要項で行います。

注2. DBXユニットを外す時はX-1000Mの電源を切ってから行う。(J501/P501は外さないこと)



図21 エンコーダ調整時の接続



図22 デコーダ調整時の接続

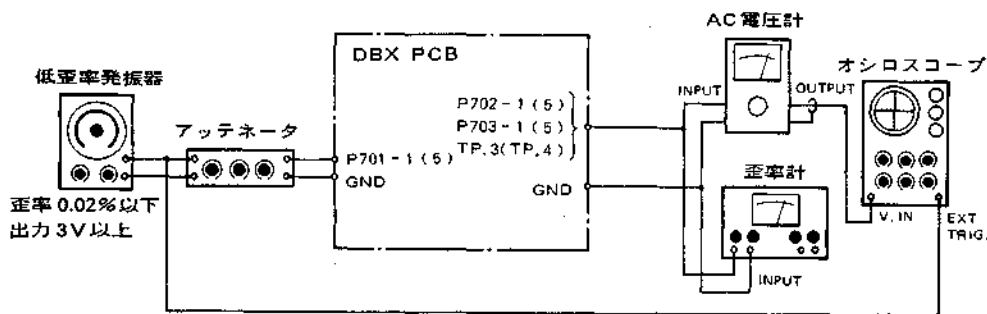

図23 VCAシンメトリ調整の接続(エンコーダ)

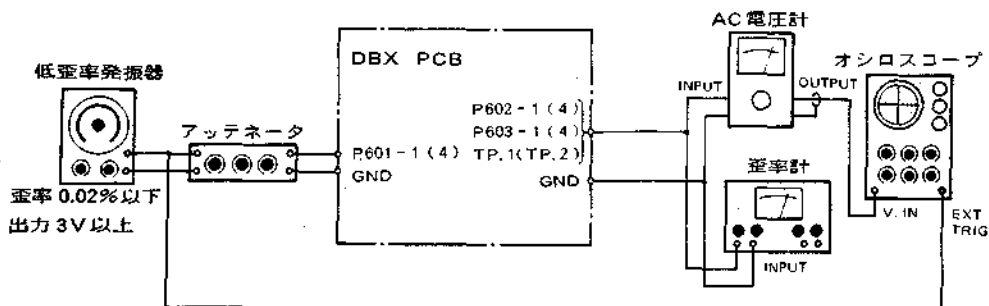

図24 VCAシンメトリ調整の接続(デコーダ)

DBX基板単体調整

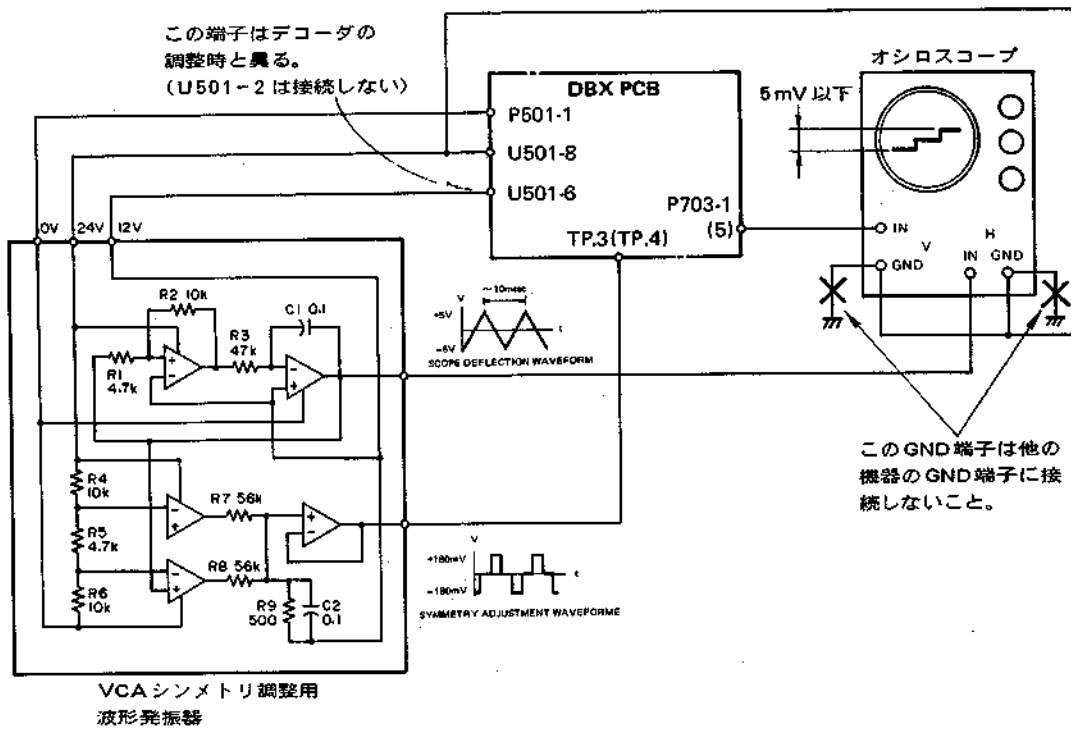
エンコーダ調整

1. 準備
 - P 701 ~ P 703 の線材を外し、図21のように測定器を接続する。(各コネクタのピン1はLch, ピン5はRch)
 - R737 (R738), R763 (R764) を中点位置にする。
2. 入力の設定
 - P 701 - 1 (5) に 100 Hz の入力を加え、P 702 - 1 (5) の出力が 300 mV になるよう入力レベルを調整する。
3. RMS SYM調整
 - TP. 3 (TP. 4) の出力波形が 200 Hz の正げん波になるよう R 765 (R 766) を調整する。
4. RMS 時定数調整
 - TP. 3 (TP. 4) の出力が $385 \mu\text{V} \pm 20\%$ であることを確認する。
5. エンコーダ基準レベル調整
 - P 701 - 1 (5) に 1 kHz の入力を加え、P 702 - 1 (5) の出力が 300 mV になるよう入力レベルを調整する。
 - 次に P 703 - 1 (5) の出力レベルが 300 mV になるよう R 737 (R 738) を調整する。
6. VCA シンメトリ調整
 - 測定器を図23のように接続する。
 - オシロスコープの波形が一直線になるよう R 757 (R 758) を調整する。(この時のレベルのズレは 5 mV 以下のこと)
7. 周波数特性チェック
 - 測定器の接続を図21に戻す。
 - 入力信号を 100 Hz, 10 kHz としたとき、R 703 - 1 (5) の出力がそれぞれ 212 mV ~ 238 mV, 165 mV ~ 185 mV であることを確認する。
8. エンコーダ効果チェック-1
 - 5 項の状態から入力信号を 1 kHz / 300 μV にしたとき P 703 - 1 (5) の出力が 8.95 mV ~ 10.1 mV であることを確認する。(1 kHz バンド・パス・フィルタを使用して測定すること)
9. エンコーダ効果チェック-2
 - 5 項の状態から入力信号を 1 kHz / 3 V にしたとき、P 703 - 1 (5) の出力が 895 mV ~ 1.01 V であることを確認する。
 - このとき歪率は 0.3 % 以下であること。

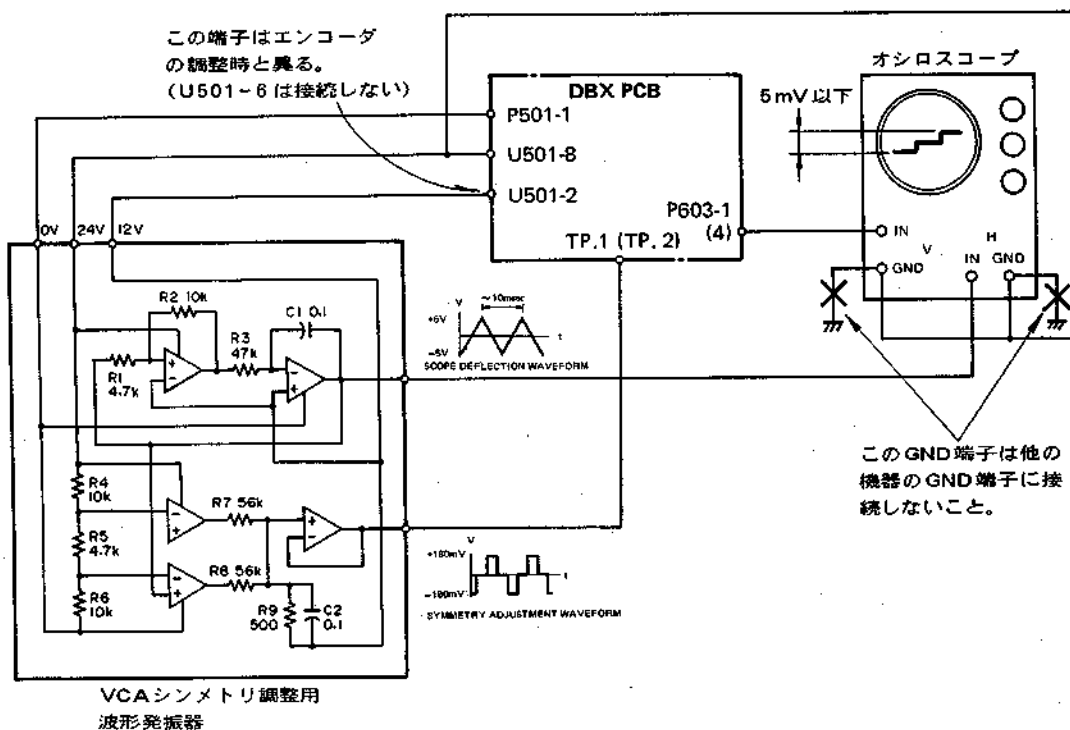
デコーダ調整

1. 準備
 - P 601 ~ P 603 の線材を外し、図22のように測定器を接続する。(各コネクタのピン1はLch, ピン4はRch) 図23
 - R 637 (R 638), R 663 (R 664) を中点位置にする。
2. 入力の設定
 - P 601 - 1 (4) に 100 Hz の入力を加え、P 602 - 1 (4) の出力が 300 mV になるよう入力レベルを調整する。
3. RMS SYM調整
 - TP. 1 (TP. 2) の出力波形が 200 Hz の正げん波になるよう R 665 (R 666) を調整する。
4. RMS 時定数調整
 - TP. 1 (TP. 2) の出力レベルが $385 \mu\text{V} \pm 20\%$ であることを確認する。
5. デコーダ基準レベル調整
 - P 601 - 1 (4) に 1 kHz の入力を加え、P 602 - 1 (4) の出力が 300 mV になるよう入力レベルを調整する。
 - 次に P 603 - 1 (4) の出力レベルが 300 mV になるよう R 637 (R 638) を調整する。
6. VCA シンメトリ調整
 - 測定器を図24のように接続する。
 - オシロスコープの波形が一直線になるよう R 657 (R 658) を調整する。(この時のレベルのズレは 5 mV 以下のこと)
7. 周波数特性チェック
 - 測定器の接続を図22に戻す。
 - 入力信号を 100 Hz, 10 kHz としたとき、P 603 - 1 (4) の出力がそれぞれ 475 mV ~ 599 mV, 789 mV ~ 993 mV であることを確認する。
8. デコード効果チェック-1
 - 5 項の状態から入力信号を 1 kHz / 9.48 mV にしたとき P 603 - 1 (4) の出力レベルが 267 μV ~ 336 μV であることを確認する。(1 kHz バンド・パス・フィルタを使用して測定すること)
9. デコード効果チェック-2
 - 5 項の状態から入力信号を 1 kHz / 948 mV にしたとき P 603 - 1 (4) の出力レベルが 2.67 V ~ 3.37 V であることを確認する。

ASSEMBLING HARDWARE CODING LIST

All screws conform to ISO standards, and have crossrecessed heads, unless otherwise noted. ISO screws have the head inscribed with a point as in the figure to the right.



FOR EXAMPLE:

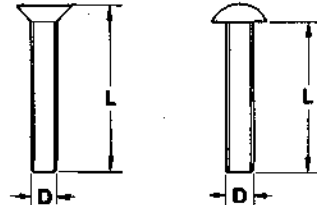
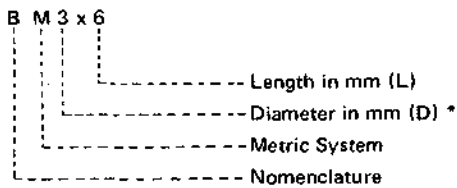

* Inner dia. for washers and nuts

	Code	Name	Type		Code	Name	Type
MACHINE SCREW	R	Round Head Screw		TAPPING SCREW	BT A	Binding Head Tapping Screw(A Type)	
	P	Pan Head Screw			BT B	Binding Head Tapping Screw(B Type)	
	T	Stove Head Screw (Truss)			RT A	Round Head Tapping Screw(A Type)	
	B	Binding Head Screw			RT B	Round Head Tapping Screw(B Type)	
	F	Flat Countersunk Head Screw		SETScrew	SF	Hex Socket Setscrew(Flat Point)	
	O	Oval Countersunk Head Screw			SC	Hex Socket Setscrew(Cup Point)	
WOOD SCREW	RW	Round Head Wood Screw	SS		Slotted Socket Setscrew(Flat Point)		
TAPTITE SCREW	PT T	Pan Head Taptite Screw		WASHER	E	E-Ring (Retaining Washer)	
	WT T	Washer Head Taptite Screw			W	Flat Washer (Plain)	
SEMS SCREW	BSA	Binding Head SEMS Screw(A Type)			SW	Lock Washer (Spring)	
	BSB	Binding Head SEMS Screw(B Type)			LWI	Lock Washer (Internal Teeth)	
	BSF	Binding Head SEMS Screw(F Type)			LWE	Lock Washer (External Teeth)	
	PSA	Pan Head SEMS Screw(A Type)			TW	Trim Washer (Countersunk)	
	PSB	Pan Head SEMS Screw(B Type)		NUT	N	Hex Nut	

EXPLODED VIEWS AND PARTS LIST

EXPLODED VIEW -1 (X-1000M)

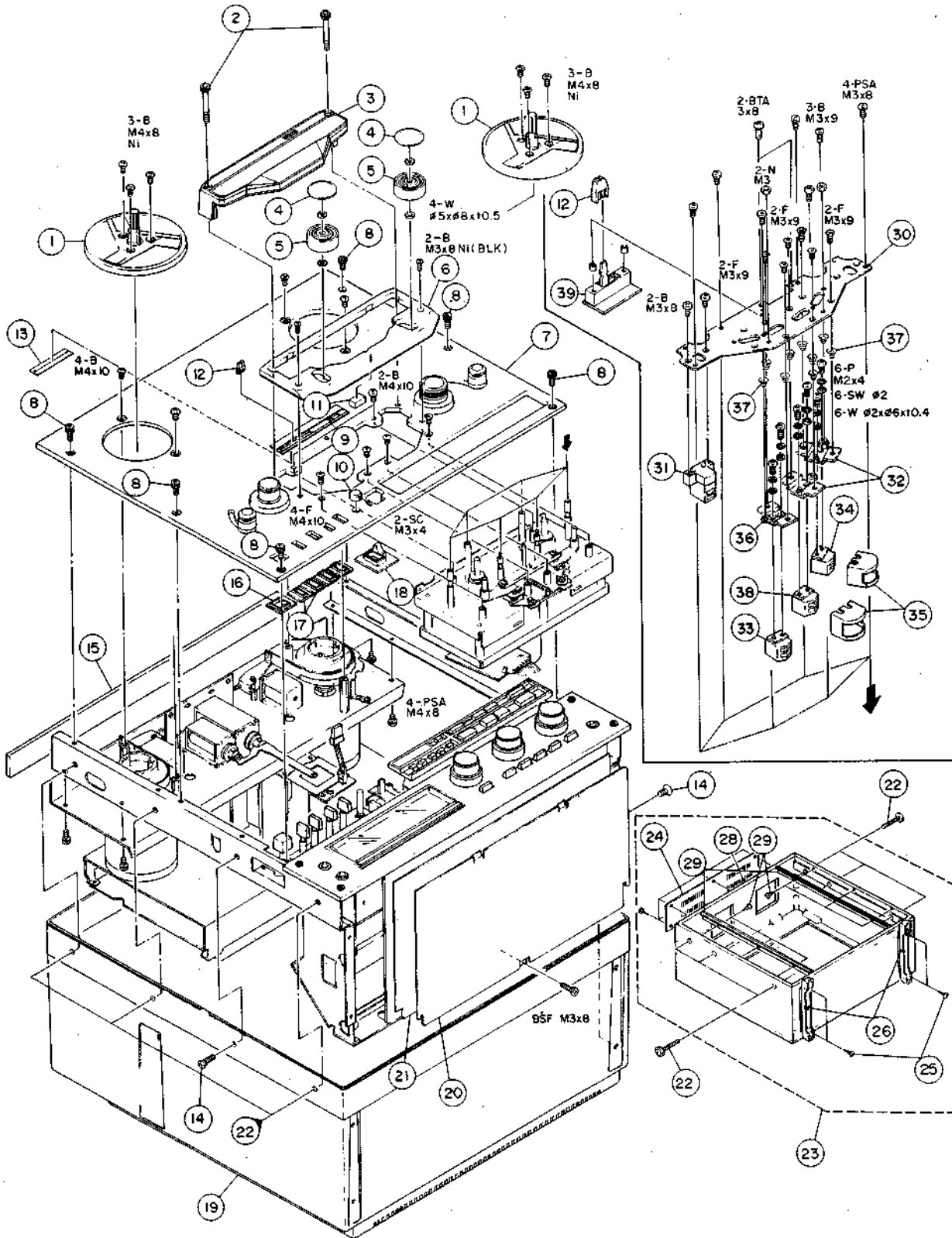

EXPLODED VIEW - 1 (X-1000M)

Parts marked with *require longer delivery time.

REF. NO.	PARTS NO.	DESCRIPTION	REMARKS
1 - 1	5504744000	Reel Table Assy	X-10R
1 - 2	*5800323400	Screw, Head Housing	
1 - 3	*5800452200	Housing Assy, Head	
1 - 4	*5800320901	Cap, Pinch Roller	X-1000R BL
1 - 5	*5014175100	Pinch Roller	A-2300
1 - 6	*5800261900	Cover, Head Base Plate	X-1000R
1 - 7	*5800385900	Panel, Top	
1 - 8	*5581073000	Screw, Top Panel; C	X-1000R BL
1 - 9	*5800362600	Escutcheon, Timer	32-28
1 - 10	5800319601	Knob, L	X-1000R BL
1 - 11	*5800002700	Chshion, Head Housing	X-10R
1 - 12	5800262500	Knob, VR	X-1000R
1 - 13	*5800315900	Mask	
1 - 14	*5780204010	Screw, F; M4 x 10	X-1000R
1 - 15	*5555887001	Cushion, Case	X-10R
1 - 16	*5800268900	Escutcheon, Power Switch	X-1000R
1 - 17	*5800268800	Escutcheon, Button	X-1000R
1 - 18	*5534708000	Escutcheon, Cue	X-1000R BL
1 - 19	*5531024102	Case, L	
1 - 20	*5553306000	Plate, Ampl. Shield	X-7
1 - 21	*5553308001	Paper, Ampl. Insulating	X-10R
1 - 22	*5504499000	Screw Assy, Case	X-1000R
1 - 23	*5800321601	Case Assy	
1 - 24	*5800349600	Ventilator	X-1000R BL
1 - 25	*5781603116	Screw, M3.1 x 16	X-1000R
1 - 26	*5504493100	Foot Assy	X-1000R
1 - 27	*5781613110	Screw, M3 x 10	X-1000R BL
1 - 28	*5800321701	Case	X-1000R BL
1 - 29	*5800321800	Sush	X-1000R BL
1 - 30	*5800363200	Plate, Head Base	X-10R
1 - 31	5800352000	E Head Assy 2T	
1 - 32	*5555673000	Bracket, Head; R	X-10R
1 - 33	5378300900	Head, Record; 2-2	
1 - 34	5378300700	Head, Playback; 4-2	X-20R
1 - 35	*5800384500	Head Shield	X-1000R
1 - 36	*5555672000	Bracket, Head; L	X-10R
1 - 37	*5520182000	Spring; D	A-5300
1 - 38	5378301000	Head, Playback; 2-2	
1 - 39	*5200098800	PCB Assy, SWITCH	

EXPLODED VIEW - 2 (X-1000)

Parts marked with *require longer delivery time.

REF. NO.	PARTS NO.	DESCRIPTION	REMARKS
2 - 1	5504744000	Reel Table Assy	X-10R
2 - 2	*5800285000	Screw, Head Housing (X-1000)	X-1000R
	*5800323400	Screw, Head Housing (X-1000 BL)	X-1000R BL
2 - 3	*5800452000	Housing Assy, Head (X-1000)	
	*5800452100	Housing Assy, Head (X-1000 BL)	
2 - 4	*5800283900	Cap, Pinch Roller; H (X-1000)	
	*5545014000	Cap, Pinch Roller (X-1000 BL)	X-10R
2 - 5	*5014750100	Pinch Roller	A-2300
2 - 6	*5800269100	Cover, Head Base Plate	X-1000R
2 - 7	*5800363400	Panel, Top (X-1000)	
	*5800385900	Panel, Top (X-1000 BL)	
2 - 8	*5581067000	Screw, Top Panel; B (X-1000)	X-10R
	*5581073000	Screw, Top Panel; C (X-1000 BL)	X-10M
2 - 9	*5800362600	Escutchen, Timer	
2 - 10	5800262700	Knob, L (X-1000)	X-1000R
	5800319601	Knob, L (X-1000 BL)	X-1000R BL
2 - 11	*5800002700	Cushion, Head Housing	X-10R
2 - 12	5800262500	Knob, VR	X-1000R
2 - 13	*5800315900	Mask	X-1000R
2 - 14	*5780204010	Screw, F; M4 x 10 (X-1000 BL)	X-1000R BL
2 - 15	*5555887001	Cushion, Case	X-10R
2 - 16	*5800268900	Escutcheon, Switch	X-1000R
2 - 17	*5800268800	Escutcheon, Button	X-1000R
2 - 18	*5800269100	Escutcheon, Cue (X-1000)	X-1000R
	*5534708000	Escutcheon, Cue (X-1000 BL)	X-1000R BL
2 - 19	*5531024102	Case, L	X-10R
2 - 20	*5533190000	Foot (X-1000)	X-10R
2 - 21	*5553306000	Plate, Ampl. Shield	X-7
2 - 22	*5553308001	Paper, Ampl. Insulating	X-7
2 - 23	*5504499000	Screw Assy, Case (X-1000 BL)	A-480
2 - 24	*5800321601	Case Assy	
2 - 25	*5800349600	Ventilator (X-1000 BL)	X-1000R BL
2 - 26	*5781603116	Screw, M3.1 x 16 (X-1000 BL)	
2 - 27	*5504493100	Foot Assy (X-1000 BL)	A-6600
2 - 28	*5781613100	Screw, M3 x 10 (X-1000 BL)	
2 - 29	*5800321701	Case (X-1000 BL)	X-1000R BL
2 - 30	*5800321801	Sush (X-1000 BL)	X-1000R BL
2 - 31	*5553289100	Plate, Head Base	X-10R
2 - 32	5800322200	Erase, Head Assy; F	X-1000R
2 - 33	*5555673000	Bracket, Head; R	X-10R
2 - 34	5378300600	Head, Record; 4-2	X-20R
2 - 35	5378300700	Head, Playback; 4-2	X-20R
2 - 36	*5554949000	Head Shield, B	A-6600
2 - 37	*5555672000	Bracket, Head; L	X-10R
2 - 38	*5520182000	Spring; D	A-5300

EXPLODED VIEW -3

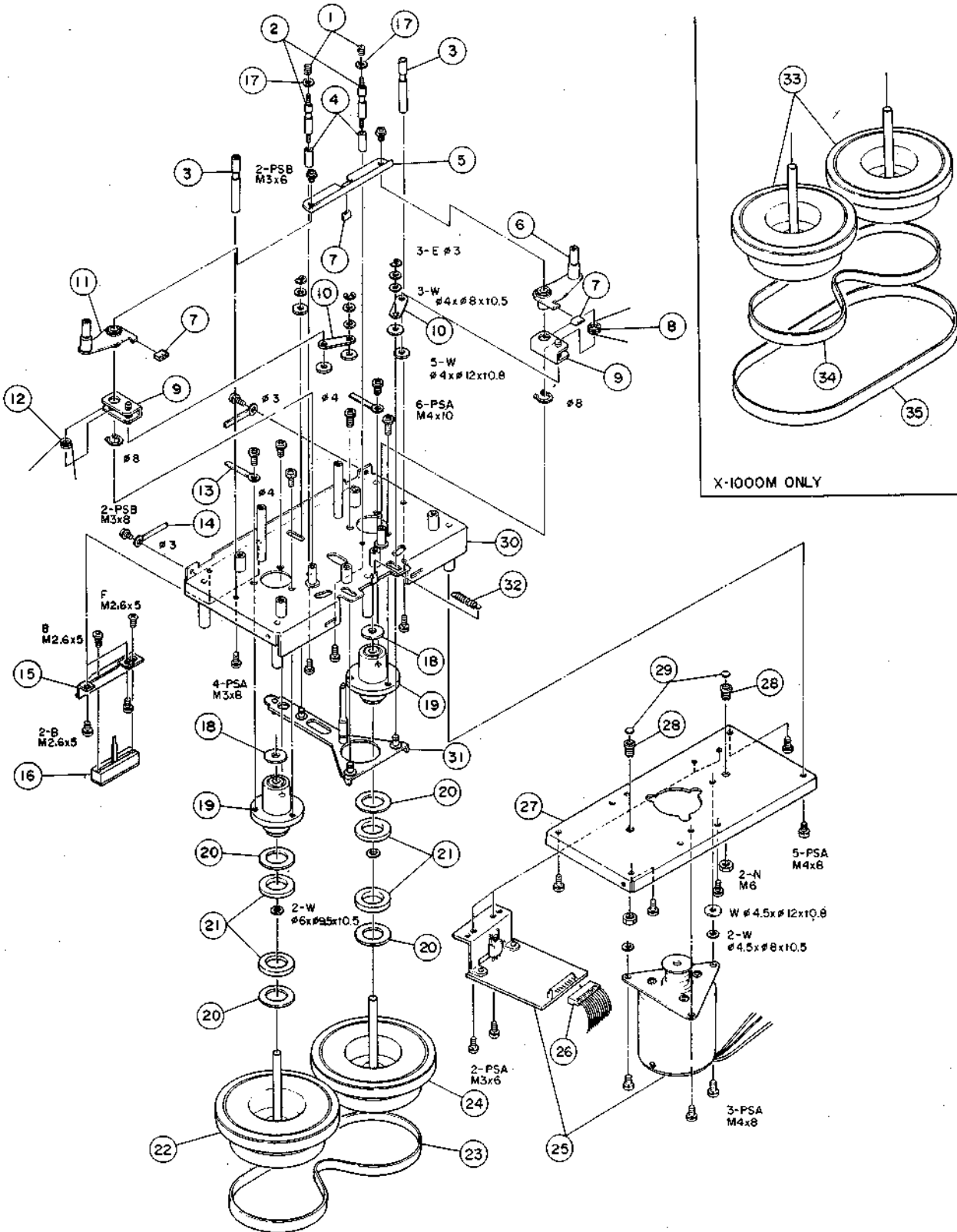

EXPLODED VIEW - 3

Parts marked with *require longer delivery time.

REF. NO.	PARTS NO.	DESCRIPTION	REMARKS
3 - 1	*5800285600	Spring, Guide	X-1000R
3 - 2	*5800285400	Tape Guide	X-1000R
3 - 3	*5545023000	Pin, Tape Guide	X-1000R
3 - 4	*5800285500	Support, Guide	X-1000R
3 - 5	*5555666000	Plate, Hold	X-10R
3 - 6	*5504729000	Arm Assy, Pinch Roller; R	X-10R
3 - 7	*5534694000	Cushion, Stopper	X-10R
3 - 8	*5524216000	Spring, Pinch Roller; R	X-10R
3 - 9	*5504731000	Bracket Assy, Pinch Roller Arm	X-10R
3 - 10	*5555667000	Plate, Joint	X-10R
3 - 11	*5504730000	Arm Assy, Pinch Roller; L	X-10R
3 - 12	*5524217000	Spring, Pinch Roller; L	X-10R
3 - 13	*5786714000	Clamper, Cord, $\phi 4$	
3 - 14	*5786713000	Clamper, Cord, $\phi 3$	
3 - 15	*5800270201	Bracket, VR	X-1000R
3 - 16	5284005500	Slide VR, 100k ohm (B)	
3 - 17	*5800286100	Washer	X-1000R
3 - 18	*5534695000	Washer, Oil Retaining	X-10R
3 - 19	5504726100	Housing Assy, Capstan Flywheel	X-10R
3 - 20	*5555704000	Tape, Adhesive	X-10R
3 - 21	*5534715000	Ring, Magnet; Thrust	X-10R
3 - 22	5504728000	Flywheel Assy, Capstan; L (X-1000/X-1000 BL)	X-10R
3 - 23	5534692001	Belt, Capstan Drive (X-1000/X-1000 BL)	
3 - 24	5504727000	Flywheel Assy, Capstan; R (X-1000/X-1000 BL)	X-10R
3 - 25	7105021001	DC Motor Assy, Capstan; F (X-1000M)	
	*7105018003	DC Motor Assy, Capstan (X-1000/X-1000 BL)	
3 - 26	*5122172000	Connector Socket, 10P (WHT)	
3 - 27	*5800138000	Plate, Bearing; F	X-20R
3 - 28	*5544003000	Screw, Bearing	A-7300
3 - 29	*5555703000	Bearing	X-10R
3 - 30	*5503196000	Chassis Assy, Capstan	X-10R
3 - 31	*5504733001	Plate Assy, Slide	X-10R
3 - 32	*5524219000	Spring, Slide Plate	X-10R
3 - 33	*5504749000	Flywheel Assy, Capstan (X-1000M)	
3 - 34	*5534693000	Belt, Flywheel (X-1000M)	
3 - 35	*5534690000	Belt, Capstan; 2T (X-1000M)	

EXPLODED VIEW 4

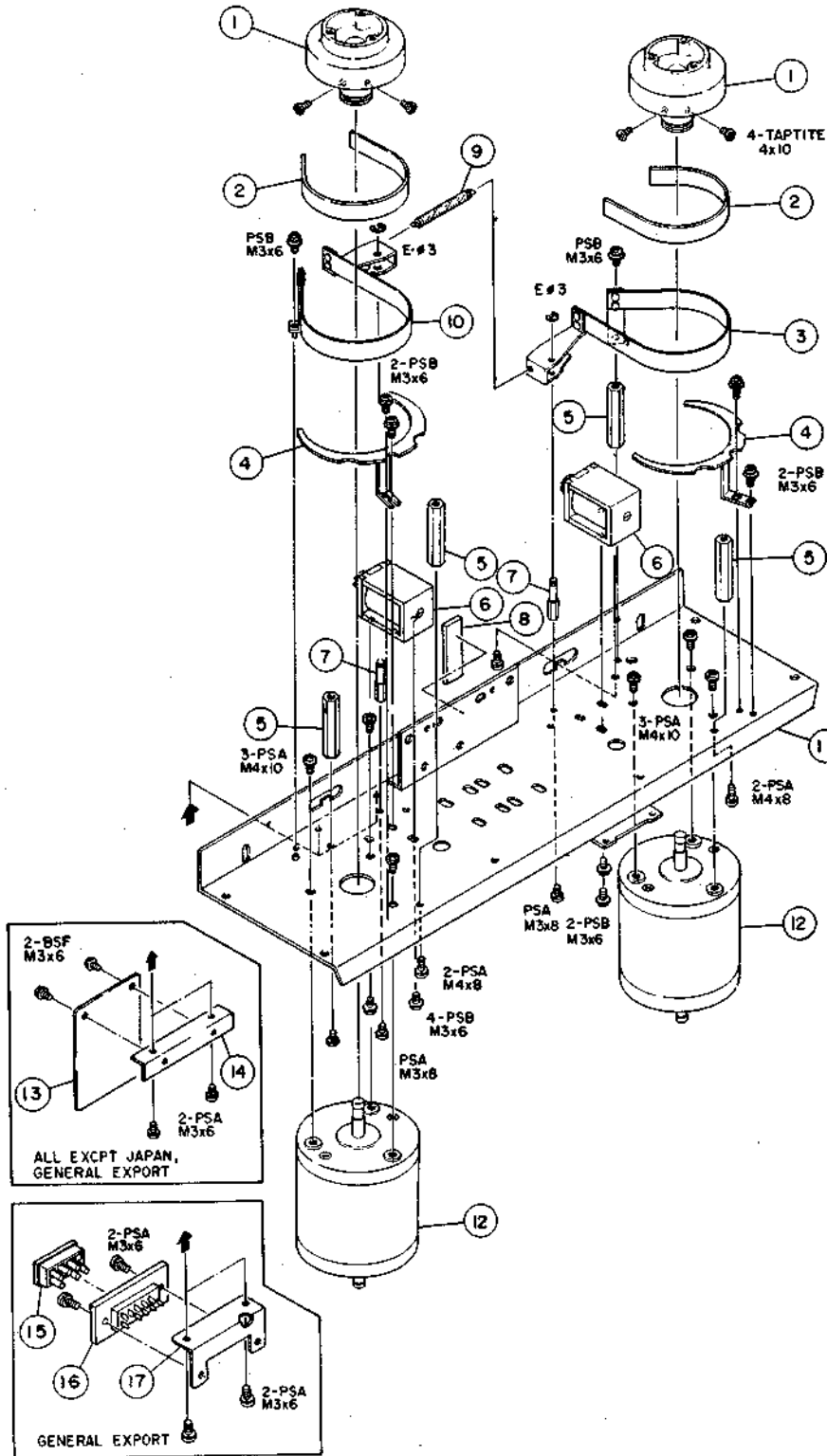

X-1000M/X-1000

EXPLODED VIEW 4

Parts marked with *require longer delivery time.

REF. NO.	PARTS NO.	DESCRIPTION	REMARKS
4 - 1	*5800346200	Base Assy, Reel Table; B	X-1000R
4 - 2	*5556274000	Shoe, Brake	A-3300SX
4 - 3	5504736000	Band Assy, Brake; R	X-10R
4 - 4	*5555685000	Plate, Band Assy Retaining	X-10R
4 - 5	*5544916000	Stay, Top Plate; A	A-6100 Mk 2
4 - 6	5163044000	Solenoid, Brake	X-10R
4 - 7	*5545033000	Shaft, Brake	X-10R
4 - 8	*5555570000	Chshion	X-10R
4 - 9	*5529249000	Spring, Brake	X-10R
4 - 10	5504735000	Band Assy, Brake; L	X-10R
4 - 11	*5503194002	Chassis Assy, Reel Motor	X-10R
4 - 12	5370003300	DC Motor, Reel	X-1000R
4 - 13	*5168997000	PCB Assy, FUSE (U, C)	
	*5158105000	PCB Assy, FUSE (E, UK, A)	
4 - 14	*5555789000	Bracket, FUSE Assy (All except GE, J)	X-1000R
4 - 15	Δ *5133014000	Plug (GE)	X-1000R
4 - 16	Δ *5133015000	Socket (GE)	X-1000R
4 - 17	*5800351800	Bracket, Switch (GE)	X-1000R

[U]: U.S.A.
[A]: AUSTRALIA
[L]: LIMITED AREA

[C]: CANADA
[E]: EUROPE
[J]: JAPAN

[GE]: GENERAL EXPORT
[UK]: U.K.

EXPLODED VIEW -5

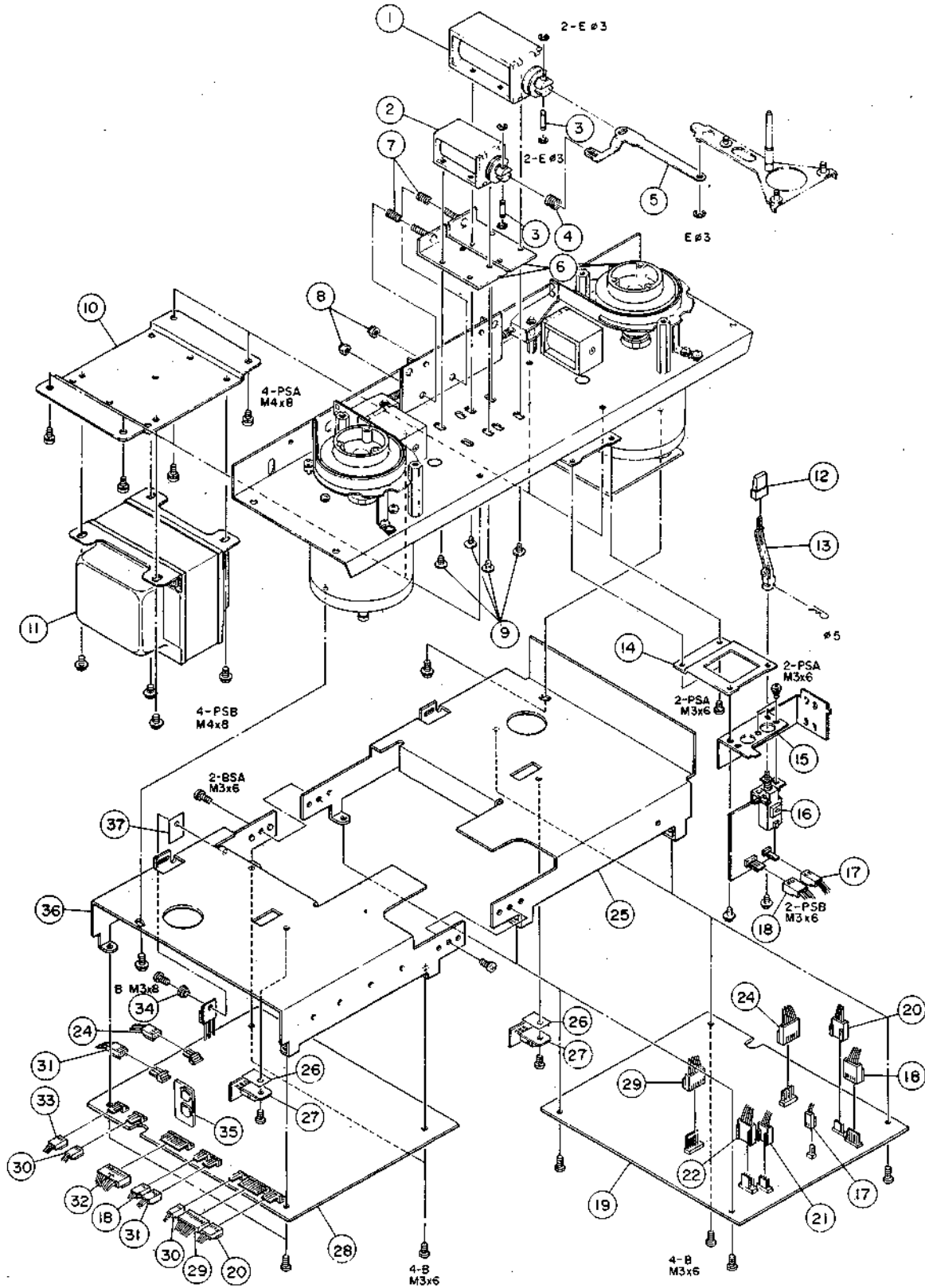

EXPLODED VIEW - 5

Parts marked with *require longer delivery time.

REF. NO.	PARTS NO.	DESCRIPTION	REMARKS
5 - 1	5163041001	Solenoid, Pinch Roller	
5 - 2	5163042000	Solenoid, Pause	
5 - 3	*5545022000	Pin, Solenoid	X-10R
5 - 4	*5524071000	Spring, Solenoid	AL-700
5 - 5	*5555668000	Plate; C	X-10R
5 - 6	*5504732000	Plate Assy, Solenoid	X-10R
5 - 7	*5524218000	Spring, Pinch Roller Pressure	X-10R
5 - 8	*5581068000	Nut, Nylon; M4	
5 - 9	*5800022600	Screw, Shoulder; G	X-10R
5 - 10	*5555681101	Bracket, Power Transformer	
5 - 11	Δ*5320014100	Transformer, Power (J)	X-1000R
	Δ*5320014200	Transformer, Power (U)	X-1000R
	Δ*5320014301	Transformer, Power (GE)	X-1000R
	Δ*5320014400	Transformer, Power (E, UK, A)	X-1000R
	*5320017300	Transformer, Power (C)	X-1000R
5 - 12	*5800262601	Button; Timer	X-1000R
5 - 13	*5534685000	Rod, Switch	X-1000R
5 - 14	*5555664000	Plate, Joint	X-10R
5 - 15	*5555671100	Bracket, Timer Switch	X-10R
5 - 16	*5200099000	PCB Assy, TIMER	
5 - 17	*5122164000	Connector Socket, 2P (WHT)	
5 - 18	*5122166000	Connector Socket, 4P (WHT)	
5 - 19	*5200067620	PCB Assy, DBX Type I (X-1000M)	
	*5200067630	PCB Assy, DBX Type II (X-1000)	
5 - 20	*5122282000	Connector Socket, 4P (RED)	
5 - 21	*5122167000	Connector Socket, 5P (WHT)	
5 - 22	*5122283000	Connector Socket, 5P (RED)	
5 - 23	*5122240000	Connector Socket, 5P (BLK)	
5 - 24	*5122223000	Connector Socket, 4P (BLK)	
5 - 25	*5800269701	Bracket, PCB; Ampl.	
5 - 26	*5800328700	Plate, Insulating	
5 - 27	*5200073100	PCB Assy, TRANSISTOR	X-1000R
5 - 28	*5200098510	PCB Assy, POWER/SERVO (X-1000M)	
	*5200098500	PCB Assy, POWER/SERVO (X-1000)	
5 - 29	*5122170000	Connector Socket, 8P (WHT)	
5 - 30	*5122165000	Connector Socket, 3P (WHT)	
5 - 31	*5122281000	Connector Socket, 3P (RED)	
5 - 32	*5122226000	Connector Socket, 7P (BLK)	
5 - 33	*5122222000	Connector Socket, 3P (BLK)	
5 - 34	*5033295000	Tube, Insulating	
5 - 35	*6200083800	PCB Assy, VR	
5 - 36	*5900269601	Bracket, PCB; SERVO	X-1000R
5 - 37	*5033291000	Plate, Insulating	

 (U): U.S.A.
 (A): AUSTRALIA
 (L): LIMITED AREA

 (C): CANADA
 (E): EUROPE
 (J): JAPAN

 (GE): GENERAL EXPORT
 (UK): U.K.

EXPLODED VIEW - 6

Part marked with *require longer delivery time.

REF. NO.	PARTS NO.	DESCRIPTION	REMARKS
6 - 1	5800270500	Roller Assy	X-1000R
6 - 2	*5504516000	Metal Holder Assy	
6 - 3	*5800270400	Base, Roller	X-1000R
6 - 4	*5504741004	Roller Assy; B	
6 - 5	*5545037000	Cap, Roller	X-10R
6 - 6	5504743004	Roller Assy; B	X-10
6 - 7	*5504742001	Base Assy, Roller; B	
6 - 8	*5783083012	Screw, M3 x 12	
6 - 9	*5600059900	T.A. Block Assy; R	
6 - 10	*5027699000	Collar, Rubber	
6 - 11	*5800270900	Spring, Tension	X-1000R
6 - 12	*5200067402	PCB Assy, TENSION SENSOR	X-1000R
6 - 13	*5800348501	Collar	X-1000R
6 - 14	*5800269801	Base Assy, Shut Off; L	X-1000R
6 - 15	*5534686001	Cushion	X-10R
6 - 16	*5524069000	Spring, Roller Arm	AL-700
6 - 17	*5800270801	Spring, Return	X-1000R
6 - 18	5800271602	Arm Assy, Tension	X-1000R
6 - 19	*5800270700	Shutter	X-1000R
6 - 20	*5581045000	Nut, Nylon	
6 - 21	*5600059800	T.A. Block Assy; L	
6 - 22	*5800269901	Base Assy, Shut Off; B	X-1000R
6 - 23	*5800447200	Reflector Assy (X-1000M)	
6 - 24	*5200067201	PCB Assy, ROLLER SENSOR (X-1000/X-1000 BL)	X-1000R
6 - 25	*5552393102	Angle, Slide; R	X-10R
6 - 26	*5800363300	Button Assy, Control	
6 - 27	*5225009600	Indicator, LED; SC-2585	
6 - 28	*5800283500	Plate, Reinforcement	X-1000R
6 - 29	*5200098700	PCB Assy, KEYBOARD	
6 - 30	*5800363100	Bracket, Button; Control	
6 - 31	*5552394101	Angle, Slide; L	X-10R
6 - 32	△ 5300017900	Switch, Power (J)	
	△ 5134037000	Switch, Power (U)	
	△ 5134018000	Switch, Power (C)	
	△ 5134036000	Switch, Power (GE)	
6 - 33	△ 5134011000	Switch, Power (E, UK, A)	
	*5052907000	Spark Killer, 0.01μF+300/300V (J, GE)	
	△*5052910000	Spark Killer, 0.033μF+120/125V (U)	
	△*5052911000	Spark Killer, 0.033μF+120/250V (C)	
	△*5267702500	Spark Killer, 0.0047μF 250V (E, UK, A)	
6 - 34	*5200098610	PCB Assy, FUNCTION SWITCH	
6 - 35	*5122282000	Connector Socket, 4P (RED)	
6 - 36	*5122240000	Connector Socket, 3P (RED)	
6 - 37	*5122283000	Connector Socket, 5P (RED)	
6 - 38	*5122170000	Connector Socket, 8P (WHT)	
6 - 39	*5200072300	PCB Assy, PITCH CONT.	X-1000R
6 - 40	*5800047801	Chassis, Control; A	32-2B
6 - 41	*5534713000	Rod, C	X-10R
6 - 42	5800268600	Button, Power Switch	X-1000R
6 - 43	5800263100	Button, Switch	X-1000R
6 - 44	*5301455500	Switch, Micro: SS5GL13-F	
6 - 45	*5504737000	Bracket Assy, Cue	X-10R
6 - 46	*5800263000	Knob, Cue	X-1000R
6 - 47	*5800401000	Lever, Cue; B	X-1000R
6 - 48	*5524223001	Spring, Cue	X-10R
6 - 49	*5800048000	Bracket, Speed Switch	32-2B
6 - 50	*5800349001	Tension Roller Assy; A	X-1000R

 [U]: U.S.A.
 [A]: AUSTRALIA
 [L]: LIMITED AREA

 [C]: CANADA
 [E]: EUROPE
 [J]: JAPAN

 [GE]: GENERAL EXPORT
 [UK]: U.K.

EXPLODED VIEW -7

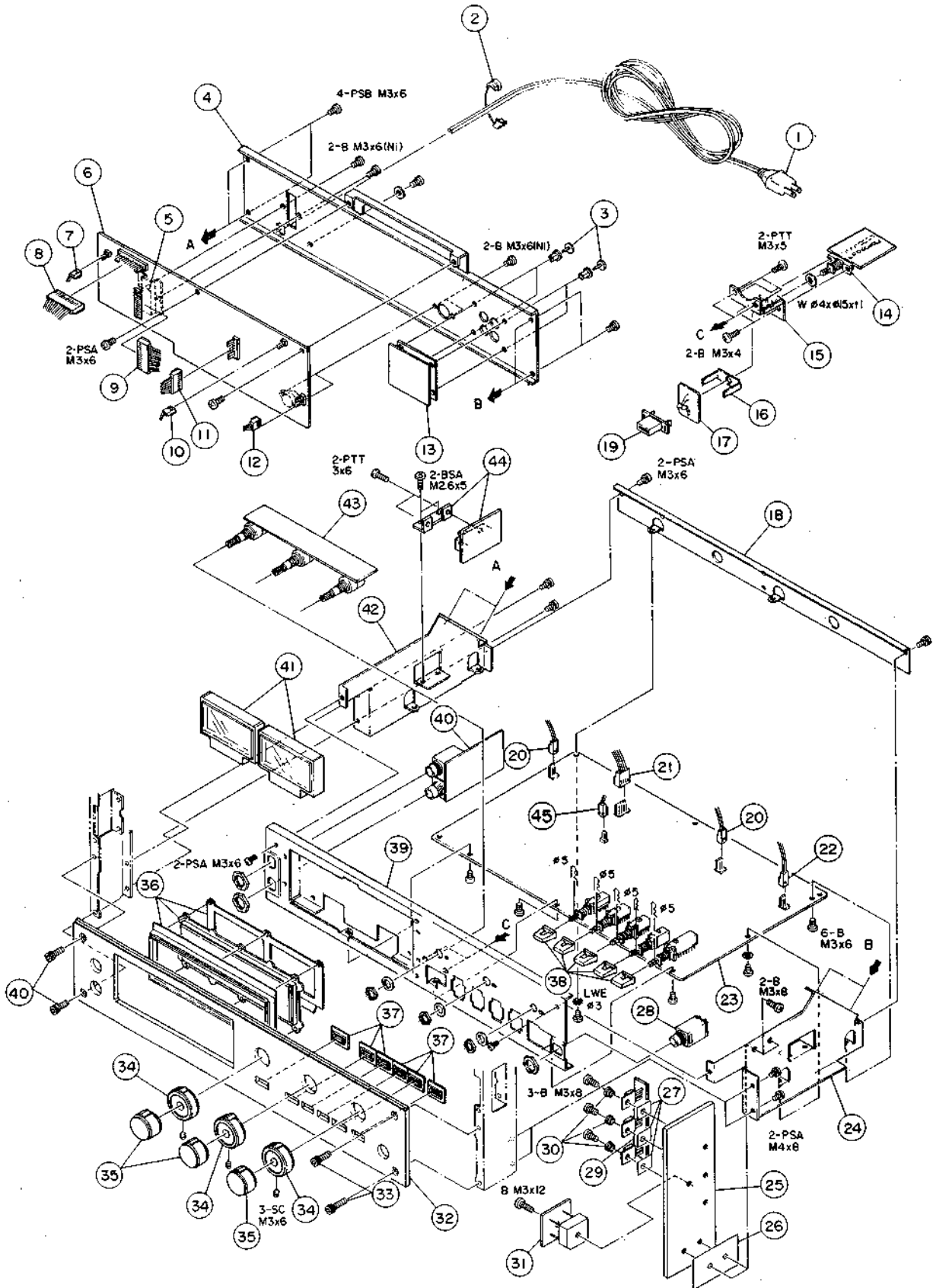

EXPLODED VIEW - 7

Part marked with *require longer delivery time.

REF. NO.	PARTS NO.	DESCRIPTION	REMARKS
7 - 1	△*5128027000 △*5128075000 △*5350008200 △*5128047000 *5350008300	Cord, AC Power (J) Cord, AC Power (U, C, GE) Cord, AC Power (E) Cord, AC Power (UK) Cord, AC Power (A)	
7 - 2	*5534660000 *5534661000	Strain Relief, AC Power Cord (All except UK) Strain Relief, AC Power Cord (UK)	
7 - 3	*5534118000	Push Rivet	
7 - 4	*5800270301	Panel, Ampl.; Rear:H	X-1000R
7 - 5	*5800283400	Bracket, Connector	X-1000R
7 - 6	*5200098400	PCB Assy, CONTROL	
7 - 7	*5122164000	Connector Socket, 2P (WHT)	
7 - 8	*5122176000	Connector Socket, 14P (WHT)	
7 - 9	*5122177000	Connector Socket, 15P (WHT)	
7 - 10	*5122280000	Connector Socket, 2P (RED)	
7 - 11	*5122170000	Connector Socket, 8P (WHT)	
7 - 12	*5122165000	Connector Socket, 3P (WHT)	
7 - 13	*5200036000	PCB Assy, IN/OUTPUT	X-1000R
7 - 14	*5200072410	PCB Assy, DBX SWITCH	
7 - 15	*5800140402	Bracket, Push Switch	
7 - 16	*5800385700	Button, Holder; G	
7 - 17	*5200072500	PCB Assy, LED	
7 - 18	*5553297100	Bracket, REC AND PLAY AMPL. PCB	X-10R
7 - 19	5800385400	Button, DBX; J	
7 - 20	*5122164000	Connector Socket, 2P (WHT)	
7 - 21	*5122166000	Connector Socket, 4P (WHT)	
7 - 22	*5122280000	Connector Socket, 2P (RED)	
7 - 23	*5200080611 *5200080601	PCB Assy, REC/PLAY AMPL. (X-1000M) PCB Assy, REC/PLAY AMPL. (X-1000)	
7 - 24	*5553295102	Frame, Ampl.; A, F	X-10R
7 - 25	*5800296601	Heat Sink	X-1000R
7 - 26	*5800328700	Plate, Insulating	X-1000R
7 - 27	*5033291000	Plate, Insulating	
7 - 28	*5124026000	Jack, PHONES	
7 - 29	5200079100	PCB Assy, TRANSISTOR; B	X-1000R
7 - 30	*5033295000	Tube, Insulating	
7 - 31	5200079000	PCB Assy, DIODE	
7 - 32	*5800386000 *5800363600	Plate, Ampl. (X-1000 BL) Plate, Ampl. (X-1000)	
7 - 33	*5581073000	Screw, Ampl. Panel; C (X-1000M/X-1000 BL)	
7 - 34	*5581067000 5800319801 5800262900	Screw, Ampl. Panel; B (X-1000) Knob, VR; N (X-1000M/X-1000 BL) Knob, VR; N (X-1000)	
7 - 35	5800319701 5800262800	Knob, VR; M (X-1000M/X-1000 BL) Knob, VR; M (X-1000)	
7 - 36	*5800319201 *5800262000	Escutcheon Assy (X-1000M/X-1000 BL) Escutcheon Assy (X-1000)	
7 - 37	*5800269000	Escutcheon, Button; H (X-1000 M)	X-1000R
7 - 38	5800268700	Button	
7 - 39	*5800246702	Chassis Assy, Ampl.	
7 - 40	*5200045510	PCB Assy, MIC AMPL.	
7 - 41	5296005100 5296004900	Meter, VU (X-1000M/X-1000 BL) Meter, VU (X-1000)	X-1000R BL X-1000R
7 - 42	*5553294102	Frame, Ampl.; A, L	X-10R
7 - 43	*5200035900	PCB Assy, VOLUME	X-10R
7 - 44	*5200099700	PCB Assy, EQ SWITCH (X-1000M)	
7 - 45	*5122280000	Connector Socket, 2P(RED)	

SEMICONDUCTOR ELECTRODES

<p>LM6402A LM6405A</p> <p>(TOP VIEW)</p>	<p>LC7800</p> <p>(TOP VIEW)</p>	<p>TD62302A TD62504P</p> <p>(TOP VIEW)</p>	<p>HD14011BP HD14066BP HD14584B</p> <p>(TOP VIEW)</p>	<p>TA75558P TA7557P</p> <p>(TOP VIEW)</p>	<p>LM2904N</p> <p>(TOP VIEW)</p>
<p>NJM2403D NJM4558D</p> <p>(TOP VIEW)</p>	<p>μPC1252H-2 μPC1253H-2</p> <p>(SIDE VIEW)</p>	<p>2SK-68AL</p>	<p>2SA733(P) 2SA933LN(S) 2SA950(Y) 2SA1015(GR)</p>	<p>2SB507(E)</p>	<p>2SC536(F)</p>
<p>2SC1061(C)</p>	<p>2SC945L(K) 2SC1318(S) 2SC1327(T) 2SC1740LN(S) 2SC1815G(R) 2SD655E</p>	<p>2SD313(E)</p>	<p>2SD718(O)</p>	<p>M4P-51</p> <p>(BOTTOM VIEW)</p>	
<p>1S2473HJ 1S2473VE</p>	<p>1N60</p>	<p>EQA01-06S</p>	<p>ERB12-02G1</p>	<p>WZ-090</p>	

[U]: U.S.A. [C]: CANADA [GE]: GENERAL EXPORT
 [A]: AUSTRALIA [E]: EUROPE [UK]: U.K.
 [L]: LIMITED AREA [J]: JAPAN

X-1000M/X-1000 X-1000M/X-1000

PC BOARDS AND PARTS LIST

PC Boards shown viewed from foil side
REC/PLAY AMPL. PCB ASSY

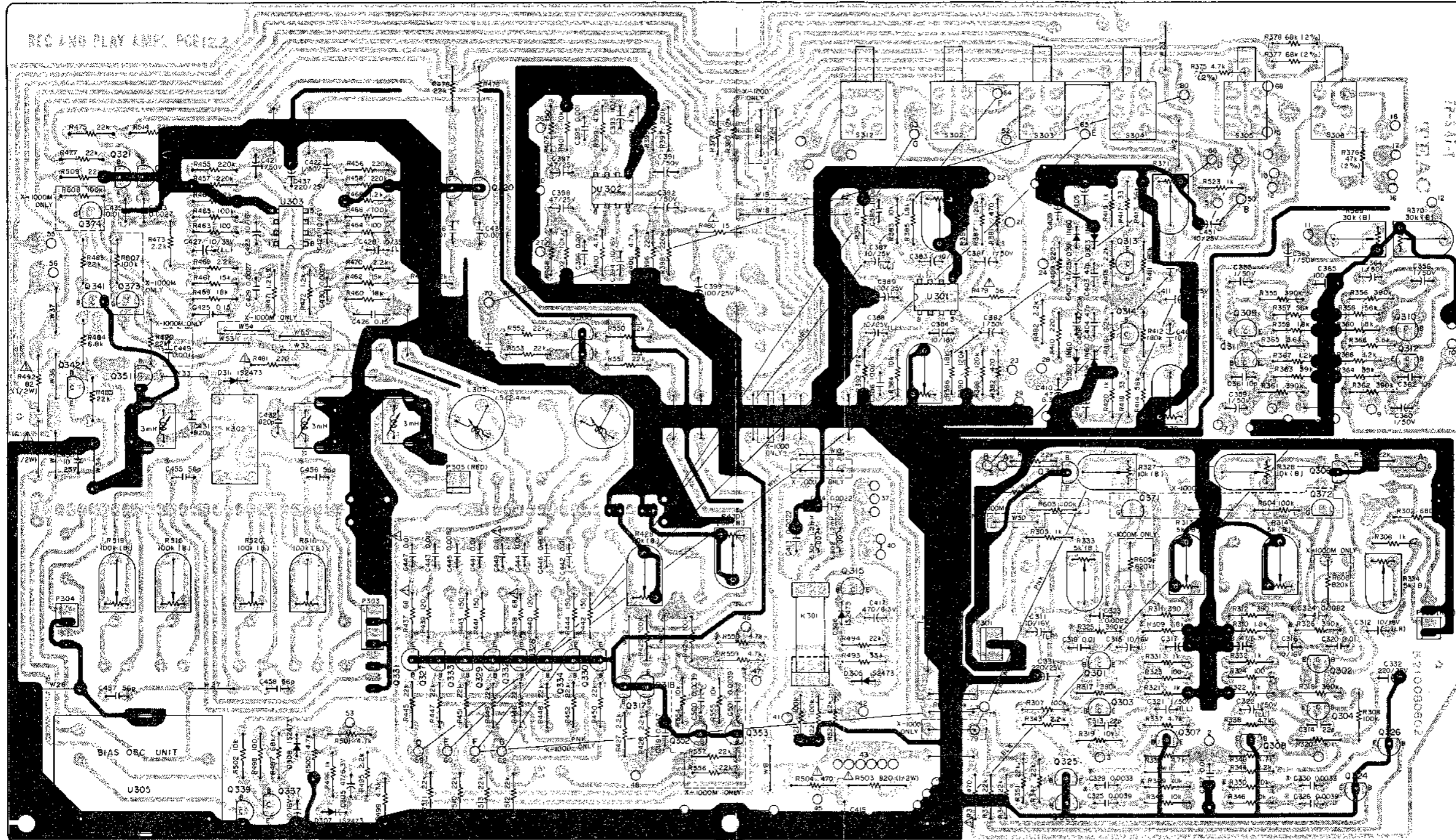

* X-1000

C323	0.039	C324	0.039	C325	0.0033	C326	0.0033
C329	0.0082	C330	0.0082	C443	0.015	C444	0.015
C455	39p	C456	39p	C458	33p		
R309	1k	R310	1k	R325	270k	R326	270k
R349	5.6k	R350	5.6k	R425	120k	R426	120k
R437	150	R438	150	R439	150	R440	150
R441	120	R442	120	R443	120	R444	120
R471	1.8k	R472	1.8k	R550	33k	H551	33k
R558	JUMPER	W29		R559	JUMPER	W28	
R559	JUMPER	W7		L305	2.4/4.2mH	L306	2.4/4.2mH

POWER/SERVO PCB ASSY

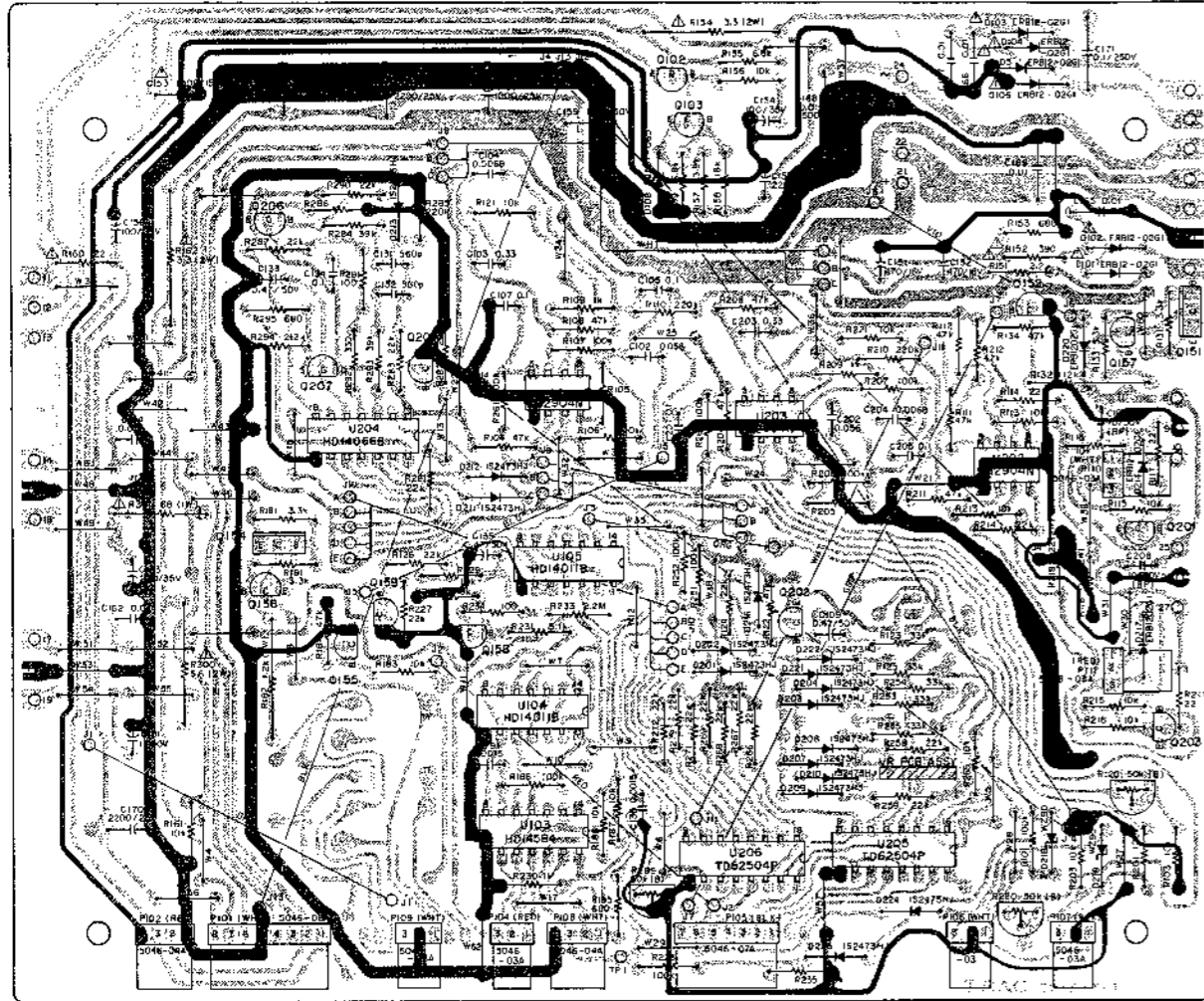

R286	5223	0210
X - RUCO	50K	152675HJ W7-090 162000985-00
X - COUM	180K	52000985-10

VR PCB ASSY (POWER/SERVO)

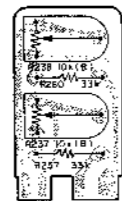

DBX PCB ASSY

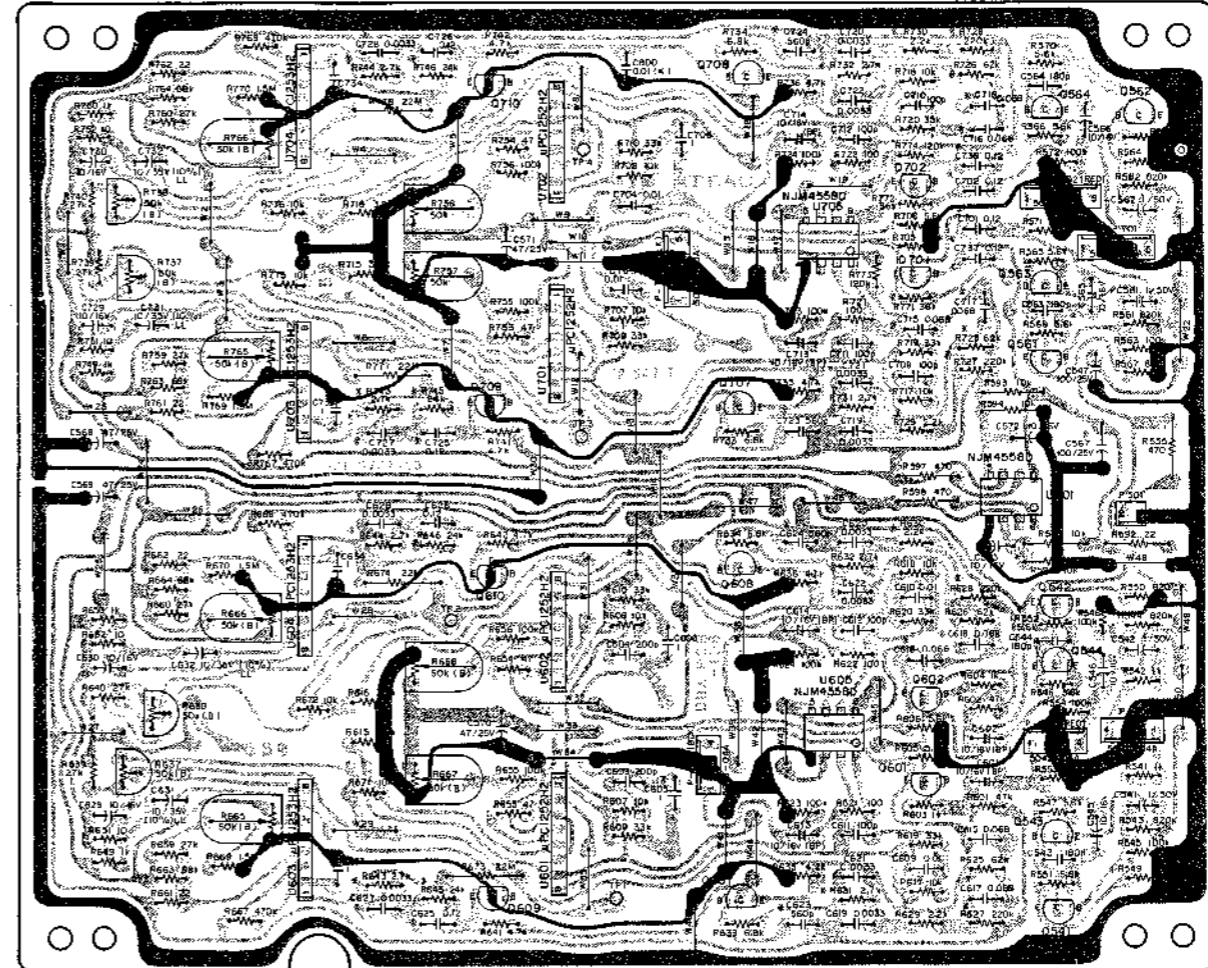

X X-1000

R625 33K	R645 33K	R763 3.3K	C617 0.1	C706 0.5	C728 0.01
R626 33K	R646 33K	R764 3.3K	C618 0.1	C707 0.5	C729 0.01
R627 91K	R723 55K	R145 33K	C623 330P	C716 0.1	C730 0.1
R628 91K	R724 55K	R146 33K	C624 330P	C717 0.1	C731 0.001/25V
R629 4.7K	R725 91K	R147 30K	C625 0.1	C718 0.1	
R630 4.7K	R726 91K	R148 30K	C626 0.1	C719 300P	
R631 33K	R727 4.7K	C605 0.5	C627 0.01	C724 350P	
R632 33K	R728 4.7K	C606 0.5	C628 0.01	C725 0.1	
R633 33K	R729 33K	C615 0.1	C701 0.1	C726 0.1	
R644 3.3K	R730 33K	C616 0.1	C702 0.1	C727 0.01	

NOTES

1. PCB Board shown viewed from foil side.
2. The colors used on the PCB illustrations have the following significance:
 : +B power supply circuit
 : GND
 : Other
3. Resistor values are in ohms (k = 1,000 ohms).
4. All capacitor values are in microfarads (p = picofarads).

REC/PLAY AMPL. PCB ASSY

REF. NO.	PARTS NO.	DESCRIPTION
	5200080611	PCB Assy [X-1000M]
	5200080601	PCB Assy [X-1000]
	5210080611	PCB [X-1000M]
	5210080601	PCB [X-1000]
IC's		
U301, U303	5220410900	TA75558P
U302	7220412200	TA7557P
TRANSISTORS		
Q301, Q302	5042461000	2SC132TT
Q303~Q308	5145036000	2SC945LK
Q309~Q312	5145092000	2SC1T40LNS
Q313~Q315	5145036000	2SC945LK
Q317, Q318	5145185000	2SD655E
Q319~Q326	5145036000	2SC945LK
Q327~Q334	5145092000	2SC1740LNS
Q337	5145036000	2SD945LK
Q339	5146185000	2SC655E
Q341	5145036000	2SC945LK
Q342	5145150000	2SA1015QR
Q351	5145036000	2SC945LK
Q352, Q353	5145036000	2SC945LK [X-1000M]
Q360, Q361	5145036000	2SC945LK
Q371, Q372	6048071000	2N5462 [X-1000M]
Q373, Q374	5232007600	2SK336, FET [X-1000M]
DIODES		
D301~D304	5042213000	IN60
D305~D308	5042517000	1S2473VE
D311	5042517000	1S2473VE
CARBON RESISTORS		
All resistors are rated ±5% tolerance and ¼W.		
R301, R302	5181550000	680kΩ
R305, R306	5181482000	1kΩ
R307, R308	5181530000	100kΩ
R309, R310	5181482000	1kΩ
R311, R312	5181472000	390Ω
R317, R318	5181544000	390kΩ
R319, R320	5181506000	10kΩ
R321, R322	5181482000	1kΩ
R323, R324	5181458000	100Ω
R325, R326	5181544000	390kΩ [X-1000M]
	5181540000	270kΩ [X-1000]
R331, R332	5181482000	1kΩ [X-1000]
R337~R340	5181498000	4.7kΩ
R341, R342	5181514000	22kΩ
R343, R344	5181490000	2.2kΩ
R345, R346	5181506000	10kΩ
R347, R348	5181514000	22kΩ
R349, R350	5181506000	5.6kΩ
R351, R352	5181514000	22kΩ
R355, R356	5181544000	390kΩ
R357, R358	5181524000	56kΩ
R359, R360	5181488000	1.8kΩ
R361, R362	5181544000	390kΩ
R363, R364	5181420000	39kΩ
R365, R366	5181500000	5.6kΩ
R367, R378	5181484000	1.2kΩ
R373	Δ5184265000	470Ω Nonflammable
R365, R376	5185132000	47kΩ 2%
R377, R378	5185136000	68kΩ 2%
R379, R380	5181508000	12kΩ
R381, R382	5181474000	470Ω

REF. NO.	PARTS NO.	DESCRIPTION
R383, R384	5181506000	10kΩ
R385, R386	5181488000	1.8kΩ
R387~R390	5181532000	120kΩ
R391, R392	5181522000	47kΩ
R393, R394	5181476000	560Ω
R395~R398	5181538000	220kΩ
R399, R400	5181498000	4.7kΩ
R401, R402	5181506000	10kΩ
R405, R406	5181498000	4.7kΩ
R407, R408	5181462000	150Ω
R409, R410	5181466000	220Ω
R411, R412	5181536000	180kΩ
R413, R414	5181524000	56kΩ
R415, R416	5181490000	2.2kΩ
R417, R418	5181446000	33Ω
R419, R420	5181482770	1kΩ
R421, R422	5181513000	100kΩ
R425, R426	5181532000	120kΩ
R427, R428	5181490000	2.2kΩ
R437, R438	5181484000	1.2kΩ [X-1000M]
R437~R440	5181462000	150Ω [X-1000]
R441~R444	5181460000	120Ω [X-1000]
R445~R452	5181514000	22kΩ
R453, R454	5181482000	1kΩ
R455~R458	5181538000	220kΩ
R459, R460	5181512000	18kΩ
R461, R462	5181510000	15kΩ
R463, R464	5181458000	100Ω
R465, R466	5181530000	100kΩ
R467, R478	5181484000	1.2kΩ
R469, R470	5181490000	2.2kΩ
R471, R472	5181484000	1.2kΩ
R473, R474	5181490000	2.2kΩ
R475~R478	5181514000	22kΩ
R479	Δ5184243000	56Ω Nonflammable
R480	Δ5184229000	15Ω Nonflammable
R481	Δ5184257000	220Ω Nonflammable
R482	5181490000	2.2kΩ
R483	5181514000	22kΩ
R484	5181502000	6.8kΩ
R485	5181514000	22kΩ
R490	5181514000	22kΩ
R491	Δ5181990000	47Ω Nonflammable
R492	Δ5181996000	82Ω Nonflammable
R493	5181518000	33kΩ
R494	5181514000	22kΩ
R495	5181490000	2.2kΩ
R496	5181482000	1kΩ
R497	5181526000	68kΩ
R498	5181458000	100Ω
R499~R401	5181498000	4.7kΩ
R502	5181506000	10kΩ
R504	Δ5184265000	470Ω Nonflammable
R509~R514	5181514000	22kΩ
R523	5181482000	1kΩ
R524	5181484000	1.2kΩ
R550, R551	5181514000	22kΩ [X-1000M]
	5181518000	33kΩ [X-1000]
R552, R553	5181514000	22kΩ
R554, R555	5181506000	10kΩ [X-1000M]
R556, R557	5181514000	22kΩ [X-1000M]
R601, R602	5181506000	10kΩ [X-1000M]
R603, R604	5181530000	100kΩ [X-1000M]
R605, R606	5181552000	820kΩ [X-1000M]
R607, R608	5181530000	100kΩ [X-1000]

REF. NO.	PARTS NO.	DESCRIPTION
CAPACITORS		
C305	5260165052	Elec. 47 μ F 10V 20%
C306	5260165552	Elec. 10 μ F 16V 20%
C311, C312	5171590000	Elec. 10 μ F 16V 20%
C313, C314	5172304000	Ceramic 22pF 50V 10%
C315, C316	5260162550	Elec. 10 μ F 16V 20%
C317, C318	5260165052	Elec. 47 μ F 10V 20%
C319, C320	5154844570	Myler 0.01 μ F 100V 5%
C321, C322	5260226110	Elec. 1 μ F 50V 10%
C323, C324	5170423000	Myler 0.0082 μ F 100V 5%[X-1000M]
	5054924500	Myler 0.039 μ F 100V 5%[X-1000]
C325, C326	5054890500	Myler 0.0039 μ F 100V 5%[X-1000M]
	5054881500	Myler 0.0033 μ F 35V 5% [X-1000]
C327	5054877500	Myler 0.01 μ F 100V 5%
C329, C330	5054881500	Myler 0.0033 μ F 35V 5%[X-1000M]
	5054894500	Myler 0.0082 μ F 100V 5%[X-1000]
C331, C332	5173056800	Elec. 220 μ F 25V
C355, C356	5260160750	Elec. 1 μ F 50V 20%
C359, C360	5260160750	Elec. 1 μ F 50V 20%
C361, C362	5172300000	Ceramic 10pF 50V 20%
C363, C364	5260160750	Elec. 1 μ F 50V 20%
C365	5260166152	Elec. 100 μ F 25V 20%
C381, C382	5260160750	Elec. 1 μ F 50V 20%
C383, C384	5260162552	Elec. 10 μ F 16V 20%
C385, C386	5172312000	Ceramic 100pF 50V 10%
C387, C388	5260222050	Elec. 10 μ F 35V 10%
C389	5260166152	Elec. 100 μ F 25V 20%
C391, C392	5260160750	Elec. 1 μ F 50V 20%
C393, C394	5260162550	Elec. 10 μ F 16V 20%
C395, C396	5054878500	Myler 0.01 μ F 100V 5%
C397, C398	5260165252	Elec. 47 μ F 25V 20%
C399	5260166150	Elec. 100 μ F 25V
C401, C402	5260162550	Elec. 10 μ F 16V
C403, C404	5172308000	Ceramic 47 μ F 50V 10%
C405, C406	5260166752	Elec. 220 μ F 6.3V
C407, C408	5260162050	Elec. 4.7 μ F 35V
C409, C410	5260165052	Elec. 47 μ F 10V
C411	5260166152	Elec. 100 μ F 25V
C413, C414	5054876500	Myler 0.0022 μ F 100V 5%
C415	5260166152	Elec. 100 μ F 25V
C417	5173070000	Elec. 470 μ F 6.3V
C419	5054738500	Myler 0.047 μ F 100V 5%
C421, C422	5260160750	Elec. 1 μ F 50V 20%
C423, C424	5260162550	Elec. 10 μ F 16V 20%
C425, C426	5054930500	Myler 0.15 μ F 100V 5%
C427, C428	5260222050	Elec. 10 μ F 35V 20%
C429, C430	5054889500	Myler 0.0027 μ F 100V 5%
C431, C432	5172820600	Polyst. 820pF 50V 5%
C433, C434	5054889500	Myler 0.0027 μ F 100V 5%
C435, C436	5054877500	Myler 0.01 μ F 100V 5%
C437	5173055800	Elec. 220 μ F 25V
C441, C442	5054877500	Myler 0.01 μ F 100V 5%
C443, C444	5170427000	Myler 0.012 μ F 100V 5%[X-1000M]
	5054887500	Myler 0.015 μ F 100V 5%[X-1000]
C445, C446	5054894500	Myler 0.0082 μ F 100V 5%
C447, C448	5054877500	Myler 0.01 μ F 100V 5%
C449	5054877500	Myler 0.01 μ F 100V 5%[X-1000]
C450, C451	5260162540	Elec. 10 μ F 25V
C455~C458	5172798000	Polyst. 59pF 50V 5%[X-1000M]
C455, C456	5172794000	Polyst. 39pF 50V [X-1000]
C457, C458	5172792000	Polyst. 33pF 50V 5%
C500, C501	5054878500	Myler 0.0039 μ F 100V 5%[X-1000M]
C554	5054877500	Myler 0.01 μ F 100V 5%

REF. NO.	PARTS NO.	DESCRIPTION
VARIABLE RESISTORS		
R313, R314	5280003302	Semi-fixed 5k Ω (B)
R327, R328	5280003502	Semi-fixed 10k Ω (B)
R333, R334	5280003302	Semi-fixed 5k Ω (B)
R369, R370	5280003802	Semi-fixed 30k Ω (B)
R371, R372	5280003602	Semi-fixed 20k Ω (B)
R403, R404	5280003502	Semi-fixed 10k Ω (B)
R429, R430	5280003602	Semi-fixed 20k Ω (B)
R515, R516	5280004202	Semi-fixed 100k Ω (B)
R519, R520	5280004202	Semi-fixed 100k Ω (B)
COILS		
L301, L302	5160170000	Choke 1200 μ H 5%
L303, L304	5056659000	Trap, 3 mH 20%
L305, L306	5056667000	Record, EQ, 1.5 - 2.4 mH 20%
	5056637000	Record, EQ, 2.4 - 4.2 mH 20%
		[X-1000M]
L310	5056659000	Dummy, 3 mH 20%
SWITCHES		
S302~S304	5300024300	Push, 2-2
S306	5134094000	Push, 2-2
S311	5134094000	Push, 2-2
S312	5134094000	Push, 2-2
CONNECTOR PLUGS		
P301	5122126000	2P
P302	5122299000	2P (RED)
P303	5122128000	4P
P304	5122126000	2P
P305	5122299000	2P (RED)
MISCELLANEOUS		
K301	5061237000	Relay, Reed; LAB2L 12V
K302	5290009400	Relay, G2V-282P 24V
U305	5040090000	OSC Unit

CONTROL PCB ASSY

REF. NO.	PARTS NO.	DESCRIPTION
	5200098400	PCB Assy
	5210098400	PCB
IC's		
U31	5220019700	LC7800
U32	5200803400	LM7402A
U33	5220015600	TD62302P
U34	5220803501	LM6405A
U35	5147065000	NJM2403D
U36, U37	5293002500	01-0299
U38	5293002600	01-0396
U39	5293002700	01-0397
TRANSISTORS		
Q31	5230016100	2SA950Y
Q32	5042383000	2SC536F
Q33	5102553000	2SA733P
Q34, Q37	5042383000	2SC536F
Q38, Q39	5042553000	2SA733P
Q40	5042383000	2SC536F
Q41	5012553000	2SA733P
Q42, Q43	5042383000	2SC536F
Q44, Q48	5230016100	2SA950Y
Q49, Q50	5142383000	2SC536F

REF. NO.	PARTS NO.	DESCRIPTION
Q51, Q53	5042553000	2SA733P
Q55 ~ Q57	5042564000	2SC1061C
Q59	5052383000	2SC536F
Q60	5042553000	2SA733P
Q62	5042625000	2SC1318S
Q63	5145129000	2SB507E
Q64	5042625000	2SC1318S
Q65	5145129000	2SB507E
Q67 ~ Q68	5042383000	2SC536F
DIODES		
D33, D34	5042517000	192743VE
D39 ~ D41	5143243000	ERB12-02G1
D44	5143243000	ERB12-02G1
RESISTORS		
All resistors are rated $\pm 5\%$ tolerance $\frac{1}{4}W$ and, of carbon type unless otherwise noted.		
R10	5184225000	10 Ω Nonfilmable
R11	5183114000	22k Ω
R12	5181482000	1k Ω
R13	5181522000	47k Ω
R14	5184763000	220 Ω 1W Metal Film
R15	5181494000	3.3k Ω
R16	5183082000	1k Ω
R17	5183122000	47k Ω
R18	5184763000	220 Ω 1W Metal Film
R19	5183094000	3.3k Ω
R20	5181554000	1M Ω
R21	5181530000	100k Ω
R22, R23	5181506000	10k Ω
R24	5181511400	22k Ω
R25	5181456000	82 Ω
R26 ~ R29	5181506000	10k Ω
R31	5181514000	22k Ω
R32	5181482000	1k Ω
R33	5183118000	33k Ω
R34	5183110000	15k Ω
R36, R37	5181506000	10k Ω
R38	5181522000	47k Ω
R39	5181514000	22k Ω
R40 ~ R42	5181506000	10k Ω
R43	518147000	330 Ω
R44	5181514000	22k Ω
R45	5181522000	47k Ω
R46	5181514000	22k Ω
R47, R48	5181506000	10k Ω
R49	5181470000	330 Ω
R50	5181506000	10k Ω
R51	5181510000	15k Ω
R52	5181522000	47k Ω
R53	5181530000	100k Ω
R54	5181510000	15k Ω
R55	5181522000	47k Ω
R56	5181530000	100k Ω
R57	5181522000	47k Ω
R58	5181506000	10k Ω
R59	5181482000	1k Ω
R60	5181486000	1.5k Ω
R61	5181506000	10k Ω
R62	5181522000	47k Ω
R63, R65	5181460000	120 Ω
R66	5181482000	1k Ω

REF. NO.	PARTS NO.	DESCRIPTION
R67 ~ R73	5181456000	82 Ω
R74 ~ R78	5181482000	1k Ω
R79	5181506000	10k Ω
R80	5181470000	330 Ω
R81	5181506000	10k Ω
R82	5181470000	330 Ω
R83, R84	5183062000	150 Ω
R85	5181460000	120 Ω
R86 ~ R88	5181506000	10k Ω
R90 ~ R92	5180062000	50 Ω
R94 ~ R96	5181514000	22k Ω
R97	5181488000	1.8k Ω
R99	5181514000	22k Ω
CAPACITORS		
C31	5260162050	Elec. 4.7 μ F 35V 20%
C32	5260165052	Elec. 4.7 μ F 10V 20%
C33	5260162050	Elec. 4.7 μ F 35V 20%
C34, C35	5054342000	Polyst. 220pF 50V 10%
C37	5260162050	Elec. 4.7 μ F 35V 20%
C38 ~ C40	5172336000	Ceramic 0.01 μ F 50V 20%
CONNECTOR PLUG		
P32	5122158000	15P
P33	5122132000	8P
P35	5122138000	14P
P37	5122127000	3P
P38	5122299000	2P (RED)
P39	5122126000	2P
MISCELLANEOUS		
CR31	5347000900	KBR-800H
J31	5334010100	Connector 12P
J36	5334025000	Socket, DIN; 5P x I330

MIC AMPL. PCB ASSY

REF. NO.	PARTS NO.	DESCRIPTION
	5200045510	PCB Assy
	5167935000	PCB
TRANSISTORS		
Q511, Q512	5042461000	2SC1327T
CARBON RESISTORS		
All resistors are rated $\pm 5\%$ tolerance and $\frac{1}{4}W$.		
R511, R512	5183082000	1k Ω
R513, R514	5183140000	270k Ω
R515, R516	5183126000	68k Ω
R517, R518	5183122000	47k Ω
R519, R520	5183060000	120 Ω
R521, R522	5183108000	12k Ω
R525	5183084000	1.2k Ω
CAPACITORS		
C511, C512	5171597000	Elec. 10 μ F 16V 20%
C513, C514	5172300000	Ceramic 10 μ F 50V 10%
C515, C516	50546461000	Dip, tant.
C517, C518	5055405000	Elec. 40 μ F 16V
C519	5055417000	Elec. 100 μ F 25V
MISCELLANEOUS		
	5124045000	Jack, MIC

X-1000M/X-1000

VR PCB ASSY

REF. NO.	PARTS NO.	DESCRIPTION
	5200035900	PCB Assy
	5120035900	PCB
CARBON RESISTORS		
R525~R528	5183058000	100Ω ¼W 5%
VARIABLE RESISTORS		
R529, R530	5282706002	Semi-fixed 50kΩ(A)
R537~R540	5282706002	Semi-fixed 50kΩ(A)

POWER/SERVO PCB ASSY

REF. NO.	PARTS NO.	DESCRIPTION
	5200098510	PCB Assy
	5210098500	PCB
IC's		
U103	5220019800	HD14584B
U104, U105	5220015900	HD14011BP
U201~U203	5220407200	LM2904N
U204	5220017100	HD14066BP
U205, U206	5293000900	TD62504P
TRANSISTORS		
Q102	5042625000	2SC1318S
Q103	5042383000	2SC536F
Q151	5145129000	2SB507E
Q152	5042625000	2SC1318S
Q154	5145129000	2SB507E
Q155	5042625000	2SC1318S
Q156, Q157	5145150000	2SA1015GR
Q158, Q159	5145151000	2SC1815GR
Q201, Q203	5145151000	2SC1815GR
Q202,	5145150000	2SA1015GR
Q205	5145151000	2SC1815GR
Q206	5145150000	2SA1015GR
Q207	5145102000	2SK68AL
DIODES		
D101~D106	5143243000	ERB12-02G1
D108	5143154000	Zener, EQA01-06S
D109, D110	5143243000	ERB12-02G1
D201~D213	5143118000	1S2473HJ
D214, D217	5143243000	ERB12-02G1
D216	5143118000	1S2473HJ
D219	5042515000	Zener, WZ-090
D220	5143243000	ERB12-02G1
D221~D222	5143118000	1S2473HJ
D224	5143118000	1S2473HJ

REF. NO.	PARTS NO.	DESCRIPTION
RESISTORS		
All resistors are rated ±5% tolerance, ¼W and of carbon type unless otherwise noted.		
R101, R201	5181530000	100kΩ
R103, R203	5181506000	10kΩ
R104, R204	5181522000	47kΩ
R105, R205	5131482000	1kΩ
R106, R206	5131530000	100kΩ
R107, R207	5181530000	100kΩ
R108, R208	5181522000	47kΩ
R109, R209	5181482000	1kΩ
R110, R210	5181538000	220kΩ
R111, R211	5181522000	47kΩ
R112, R212	5181522000	47kΩ
R113, R213	5181506000	10kΩ
R114, R214	5181514000	22kΩ
R115, R215	5181506000	10kΩ
R116, R216	5181506000	10kΩ
R117, R217	5181442000	22Ω
R118, R218	5185190000	0.22Ω 2W
R121, R221	5181506000	10kΩ
R122	5181522000	47kΩ
R123	5181518000	33kΩ
R124	5181514000	22kΩ
R125, R225	5181518000	33kΩ
R126	5181514000	22kΩ
R131, R133	5183094000	3.3kΩ
R132	5184816000	1.2kΩ 2W Meral Film
R134	5181522000	47kΩ
R151	Δ 5184209000	2.2Ω Nonflammable
R152	5181472000	390Ω
R153	5181478000	680Ω
R154	5184306000	3.3Ω 2W 10% Cement
R155	5181502000	6.8kΩ
R156	5183150600	10kΩ
R157	5181496000	3.9kΩ
R158	5181512000	18kΩ
R159	5181502000	6.8kΩ
R160	Δ 5184233000	22Ω Nonflammable
R161	5185066000	10kΩ
R162	5184306000	3.3Ω 2W 10% Cement
R181	5181494000	3.3kΩ
R182	5184816000	1.2kΩ 2W Metal Film
R183	5181506000	10kΩ
R184	5181522000	47kΩ
R185	5181478000	68Ω
R186, R187	5181506000	10kΩ
R188	5181530000	100kΩ
R191	5181494000	3.3kΩ
R226	5181518000	33kΩ
R227	5181514000	22kΩ
R228	5181530000	100kΩ
R229	5181506000	10kΩ
R230	5181554000	1MΩ
R231	5181499000	5.1kΩ
R232	5181506000	10kΩ
R233	5181562000	2.2MΩ
R234	5181458000	100Ω
R235	5181530000	100kΩ
R251, R252	5181530000	100kΩ
R253, R254	5181518000	33kΩ
R258, R259	5181514000	22kΩ
R261, R262	5181530000	100kΩ

DBX PCB Type I/Type II

REF. NO.	PARTS NO.	DESCRIPTION
R265	5181506000	10kΩ
R266~R272	5181514000	22kΩ
R281~R283	5181514000	22kΩ
R284	5181520000	39kΩ
R285	5181538000	220kΩ
R286	5181536000	180kΩ
R287	5181514000	22kΩ
R290	5181514000	22kΩ
R291	5181458000	100Ω
R292	5181470000	330Ω
R293	5181520000	39kΩ
R294	5181490000	2.2kΩ
R295	5181478000	680Ω
R300	5184304000	5.6Ω 2W Cement
R301	5184751000	68Ω 1W Metal Film
CAPACITORS		
C102, C202	5170513000	Mylar 0.056μF 100V 10%
C104, C203	5170531000	Mylar 0.33μF 100V 10%
C104, C204	5170491000	Mylar 0.068μF 100V 10%
C105, C205	5170519000	Mylar 0.1μF 100V 10%
C107, C207	5170519000	Mylar 0.1μF 100V 10%
C108, C208	5170519000	Elec. 10μF 50V 10%
C109	5260160550	Elec. 0.47μF 50V 20%
C131, C132	5171237000	Elec. 569pF 125V 10%
C133	5260160550	Elec. 0.47μF 50V 20%
C134	5170519000	Mylar 0.1μF 100V 10%
C135	5260160550	Elec. 0.47μF 50V 20%
C136	5170475000	Mylar 0.0015μF 100V 10%
C151, C152	5173072000	Elec. 470μF 16V
C153	5173084000	Elec. 1000μF 50V
C154	5173047000	Elec. 100μF 35V
C155	5173056800	Elec. 220μF 35V
C156	5173047800	Elec. 100μF 35V
C157, C158	5173089000	Elec. 2200μF 25V
C159, C160	5173084000	Elec. 1000μF 50V
C161	5260160750	Elec. 1μF 50V 20%
C162	5172336000	Ceramic 0.01μF 50V 20%
C163	5172348000	Ceramic 0.1μF 50V 10%
C164	5172336000	Ceramic 0.01μF 50V 20%
C165~C169	5267010300	Ceramic 10000pF 500V
C170	5173089000	Elec. 2200μF 25V
C171	5263164900	Metalized 0.1μF 250V 10%
C191	5170475000	Mylar 0.0015μF 100V 10%
VARIABLE RESISTORS		
R120, R220	5280001502	Semi-fixed 50kΩ (B)
R289	5280001502	Semi-fixed 50kΩ (B)
CONNECTOR PLUGS		
P101	5122151000	8P
P102	5122455000	4P (RED)
P103	5122145000	2P
P104	5122454000	3P (RED)
P105	5122150000	7P
P106	5122146000	3P
P107	5122203000	3P (BLK)
P108	5122147000	4P
P109	5122146000	3P
P110	5122146000	3P
P111	5122454000	3P (RED)

REF. NO.	PARTS NO.	DESCRIPTION
	5200067624	PCB Assy [X-1000M]
	5200067634	PCB Assy [X-1000]
	5210072703	PCB [X-1000M]
	5210072703	PCB [X-1000]
IC's		
U501	5042738000	NUM4558D
U601, U602	5220414501	μPC1252H-2
U603, U604	5220414601	μPC1253H-2
U605	5042738000	NJM4558D
U701, U702	5220414501	μPC1252H-2
U703, U704	5220414601	μPC1253H-2
U705	5042738000	NJM4558D
TRANSISTORS		
Q541, Q542	5145151000	2SC1815GR
Q543, Q544	5145132000	2SA933LNS
Q561, Q562	5145151000	2SC1815GR
Q563, Q564	5145132000	2SC933LNS
Q601, Q602	5145151000	2SC1815GR
Q607, Q608	5145151000	2SC1815GR
Q609, Q610	5145150000	2SA1015GR
Q701, Q702	5145151000	2SC1815GR
Q707, Q708	5145151000	2SC1815GR
Q709, Q710	5145150000	2SA1015GR
CARBON RESISTORS		
All resistors are rated ±5% tolerance and ¼W.		
R541, R542	5240028200	4kΩ
R543, R544	5240035200	820kΩ
R545, R546	5240033000	100kΩ
R547, R548	5240030000	5.6kΩ
R549, R550	5240028000	820Ω
R551, R552	5240030000	5.6kΩ
R553, R554	5240033000	100kΩ
R555	Δ 5184265000	470Ω Nonflammable
R561, R562	5240035200	820kΩ
R563, R564	5240033000	100kΩ
R565, R566	5240030000	5.6kΩ
R567, R568	5240028000	820Ω
R569, R570	5240030000	5.6kΩ
R571, R572	5240033000	100kΩ
R592	Δ 5184233000	22Ω Nonflammable
R593~R596	5183106000	10kΩ
R597, R598	5183074000	470Ω
R601, R602	5240032200	47kΩ
R603, R604	5240028200	1kΩ
R605, R606	5240030000	5.6kΩ
R607, R608	5240030600	10kΩ
R609, R610	5240031800	33kΩ
R615, R616	5240029600	3.9kΩ
R617, R618	5240030600	10kΩ
R619, R620	5240031800	33kΩ
R621, R622	5240025800	100Ω
R623, R624	5240033000	100kΩ
R625, R626	5240032500	62kΩ [X-1000M]
	5240031820	33kΩ [X-1000]
R627, R628	5240033800	220kΩ [X-1000M]
	5240032920	91kΩ [X-1000]
R629	5240029000	2.2kΩ [X-1000M]
R630	5240029800	4.7kΩ [X-1000]
R631, R632	5240029200	2.7kΩ [X-1000M]
	5240031820	33kΩ [X-1000]
R633, R634	5240030200	6.8kΩ
R635, R636	5340029800	4.7kΩ
R639, R640	5340031600	27kΩ
R641, R642	5240029800	4.7kΩ

X-1000M/X-1000

REF. NO.	PARTS NO.	DESCRIPTION
R643, R644	5240029420	3.3k Ω [X-1000]
R645, R646	5240031500	24k Ω [X-1000M]
	5240031820	33k Ω [X-1000]
R649, R650	5240028200	1k Ω
R651, R652	5240023400	10 Ω
R653, R654	5240025000	47 Ω
R655, R656	5240033000	100k Ω
R659, R660	5240031600	27k Ω
R661, R662	5240024200	22 Ω
R663, R664	5240032600	68k Ω
R667, R668	5240034600	470k Ω
R669, R670	5240175800	1.5M Ω
R671, R672	5240030620	10k Ω
R673, R674	5240319000	22M Ω
R705, R706	5240300000	5.6k Ω
R707, R708	5240030600	10k Ω
R709, R710	5240031800	33k Ω
R711, R712	5240029200	2.7k Ω
R715, R716	5240029600	3.9 Ω
R717, R718	5240030600	10k Ω
R719, R720	5200031800	33k Ω
R721, R722	5240025800	100 Ω
R723, R724	5240033000	100k Ω
R725, R726	5240032500	62k Ω [X-1000M]
	5240031820	33k Ω [X-1000]
R727, R728	5240032800	220k Ω [X-1000M]
	5240032920	91k Ω [X-1000]
R729, R730	5240029000	3.6k Ω [X-1000M]
	5240029820	4.7k Ω [X-1000]
R731, R732	5240029200	2.7k Ω [X-1000M]
	5240031820	33k Ω [X-1000]
R733, R734	5240030200	6.8k Ω
R735, R736	5240029800	4.7k Ω
R739, R740	5240031600	27k Ω
R741, R742	5240029800	4.7k Ω
R743, R744	5240029200	2.7k Ω [X-1000M]
	5240029420	3.3k Ω [X-1000]
R745, R746	5240031500	24k Ω [X-1000M]
	5240031820	33k Ω [X-1000]
R749, R750	5240028200	1k Ω
R751, R752	5240023400	10 Ω
R753, R754	5240025000	47 Ω
R755, R756	5240033000	100k Ω
R759, R760	5240031600	27k Ω
R761, R762	5240024200	22 Ω
R763, R764	5240032600	68k Ω
R767, R768	5240034600	470 Ω
R769, R770	5240175800	1.5M Ω
R771, R772	5240031920	36k Ω [X-1000M]
	5240031720	30k Ω [X-1000]
R773, R774	5240033220	120k Ω
R775, R776	5240030620	10k Ω [X-1000M]
R777, R778	5240319000	22M Ω [X-1000]
CAPACITORS		
C541, C542	5142882000	Elec. 1 μ F 50V
C543, C544	5142315000	Ceramic 180 μ F 50V 10%
C545, C546	5172900000	Elec. 10 μ F 16V
C547	5173046000	Elec. 100 μ F 25V
C561, C562	5172882000	Elec. 1 μ F 50V

REF. NO.	PARTS NO.	DESCRIPTION
C563, C564	5172315000	Ceramic 180pF 50V 10%
C565, C566	5172900000	Elec. 10 μ F 16V
C567	5173082000	Elec. 1000 μ F 25V
C568~C571	5173037000	Elec. 47 μ F 25V
C572, C573	5172900000	Elec. 10 μ F 16V
C601, C602	5171482000	Elec. 10 μ F 16V B.P
C603, C604	5263106100	Polyst. 200pF 100V 5%
C605, C606	5263163413	Metalized 1 μ F 50V 5% [X-1000M]
	5263163515	Metalized 0.3 μ F 50V 5% [X-1000]
C609, C610	5170425000	Myler 0.01 μ F 100V 5%
C611, C612	5172312000	Ceramic 100 μ F 50V 10%
C613, C614	5260067050	Elec. 10 μ F 16V 20%
C615~C618	5170445000	Myler 0.068 μ F 100V 5% [X-1000M]
	5263162213	Metalized 0.1 μ F 50V 5% [X-1000]
C619~C622	5170413000	Myler 0.0033 μ F 100V 5%
C623, C624	5172321000	Ceramic 560pF 50V 10%
C625, C626	5263162313	Metalized 0.12 μ F 50V 5% [X-1000M]
	5263162213	Metalized 0.1 μ F 50V 5% [X-1000]
C627, C728	5170413000	Myler 0.0033 μ F 100V 5% [X-1000M]
	5170425000	Myler 0.01 μ F 100V 5% [X-1000]
C629, C630	5173010000	Elec. 10 μ F 16V
C631, C632	5260227010	Elec. 10 μ F 35V 10%
C633, C634	5263163413	Metalized 1 μ F 50V 5%
C701, C702	5263162313	Metalized 0.12 μ F 50V 5%
C703, C704	5170425000	Myler 0.01 μ F 100V 5%
C705, C706	5263163413	Metalized 1 μ F 50V 5%
C709~C712	5172312000	Ceramic 100pF 50V 10%
C713, C714	5171482000	Elec. 10 μ F 16V
C715~C718	5170144500	Myler 0.068 μ F 100V 5% [X-1000M]
	5263162213	Metalized 0.1pF 50V 5% [X-1000]
C719~C722	5170413000	Myler 0.0033 μ F 100V 5%
C723, C724	5172321000	Ceramic 560pF 50V 10% [X-1000M]
	5263162213	Metalized 0.1 μ F 50V 5% [X-1000]
C725, C726	5263162313	Metalized 0.12 μ F 50V 5% [X-1000M]
	5263162213	Metalized 0.1 μ F 50V 5% [X-1000]
C727, C728	5170413000	Myler 0.0033 μ F 100V 5% [X-1000M]
	5170425000	Myler 0.01 μ F 100V 5% [X-1000]
C729, C730	5173010000	Elec. 10 μ F 16V
C731, C732	5260227010	Elec. 10 μ F 35V 10%
C733, C734	5263163413	Metalized 1 μ F 50V 5%
C735	5173393000	Ceramic 0.01 μ F 50V 10% [X-1000M]
C735, C736	5263162213	Metalized 0.1 μ F 50V 5% [X-1000]
C737, C738	5263162313	Metalized 0.12 μ F 50V 5% [X-1000]
VARIABLE RESISTORS		
R637, R638	5280001502	Semi-fixed 50k Ω (B)
R657, R658	5280004002	Semi-fixed 50k Ω (B)
R665, R666	5280004002	Semi-fixed 50k Ω (B)
R737, R738	5280001502	Semi-fixed 50k Ω (B)
R757, R758	5280004002	Semi-fixed 50k Ω (B)
R765, R766	5280004002	Semi-fixed 50k Ω (B)
CONNECTOR PLUGS		
P501	5122126000	2P
P601	5122128000	4P
P602	5122301000	4P (RED)
P603	5122185000	4P (BLK)
P701	5122129000	5P
P702	5122302000	5P (RED)
P703	5122186000	5P (BLD)

VR PCB ASSY (POWER/SERVO)

REF. NO.	PARTS NO.	DESCRIPTION
	5200083800	PCB Assy
	5210083800	PCB
CARBON RESISTORS		
R257, R260	5183118000	33kΩ ¼W 5%
VARIABLE RESISTORS		
R237, R238	5280003502	10kΩ (B)

TIMER PCB ASSY (PC Board omitted.)

REF. NO.	PARTS NO.	DESCRIPTION
	520009900	PCB Assy
	5210067300	PCB
MISCELLANEOUS		
S803	5300020700	Push Switch 2-2
P803	5122126000	Connector Plug, 2P
P808	5122128000	Connector Plug, 4P

DBX SWITCH PCB ASSY (PC Board omitted.)

REF. NO.	PARTS NO.	DESCRIPTION
	5200072410	PCB Assy
	5210072400	PCB
TRANSISTORS		
Q501, Q502	5145185000	2SD655E
CARBON RESISTORS		
R501, R502	5183100000	5.6kΩ 5% ¼W
SWITCH		
S501	5300030600	Push, 6-2

PITCH CONTROL PCB ASSY (PC Board omitted.)

REF. NO.	PARTS NO.	DESCRIPTION
	5200072300	PCB Assy
	5210072300	PCB
	5150239000	Var, Res 5kΩ (B)

ROLLER SENSOR PCB ASSY (PC Board omitted.)

REF. NO.	PARTS NO.	DESCRIPTION
	5200067201	PCB Assy
	5210067201	PCB
U801, U802	5228007100	Interrupter, ON1122

FUSE PCB ASSY (PC Board omitted.)

REF. NO.	PARTS NO.	DESCRIPTION
	5168997000	FUSE PCB Assy [U, C]
F1, F2	Δ5307004700	Fuse 7A 125V
F3	Δ5307004100	Fuse 2A 250V
	5041237000	Fuse Holder
	5158105000	Fuse PCB Assy [E, UK, A]
	5157105000	PCB Assy
	Δ5142193000	Mini Fuse 5A 250V
	Δ5142189000	Mini Fuse 2A 250V
	5142087000	Fuse Holder

TENSION SENSOR PCB ASSY (PC Board omitted.)

REF. NO.	PARTS NO.	DESCRIPTION
	5200067402	PCB Assy
	5210067402	PCB
RESISTORS		
R811~R813	5183060000	120Ω ¼W 5%
R814	5241151800	33kΩ ¼W 5% Metal Film
MISCELLANEOUS		
U801	5228007000	Interrupter, PH101

IN/OUTPUT TERMINAL PCB ASSY (PC Board omitted.)

REF. NO.	PARTS NO.	DESCRIPTION
	5200036000	PCB Assy
	5167987101	PCB
	5124058000	Jack, 4P
CARBON RESISTORS		
R535, R536	5183120000	39kΩ ¼W 5%

X-1000M/X-1000

TRANSISTOR B PCB ASSY (PC Board omitted.)

REF. NO.	PARTS NO.	DESCRIPTION
	5200079100	PCB Assy
	5210079100	PCB
IC's		
U820	△ 5120415100	NJM78M05A
U801	△ 5220413100	NJM78M15A
TRANSISTOR		
Q820	△ 5145087000	2SD313E
CAPACITORS		
C820~C823	5172992000	Elec. 1μF 50V
MISCELLANEOUS		
	5033291000	Plate, Insulating
	5033295000	Tube, Insulating

TRANSISTOR PCB ASSY (PC Board omitted.)

REF. NO.	PARTS NO.	DESCRIPTION
	5200073100	PCB Assy
	5210073100	PCB
Q801	5145171000	Transistor, 2SD7180

DIODE PCB ASSY (PC Board omitted.)

REF. NO.	PARTS NO.	DESCRIPTION
	5200079000	PCB Assy
	5210079000	PCB
DIODE		
D107	△ 5228008000	BA60-B1D

LED PCB ASSY (PC Board omitted.)

REF. NO.	PARTS NO.	DESCRIPTION
	5200072500	PCB Assy
	5210072500	PCB
D501, D502	5225006700	LED TLG124A (GREEN)

EQ SWITCH PCB ASSY (PC Board omitted.)

REF. NO.	PARTS NO.	DESCRIPTION
	5200099700	PCB Assy
	5210098800	PCB
	5300909300	Slide, Switch; 4-2N
	5800404500	Holder, Switch

TENSION SENSOR PCB ASSY (PC Board omitted.)

REF. NO.	PARTS NO.	DESCRIPTION
	5200067402	PCB Assy
	5210067402	PCB
CARBON RESISTOR		
All resistors are rated ±5% tolerance ¼W and, of carbon type unless otherwise noted.		
R810, R811	5241426602	5.1kΩ; LT1/8 Metal Film
R812	5183080000	82Ω
R813	5183099000	5.1kΩ
MISCELLANEOUS		
	6048807000	Interrupter, ON1102

SWITCH PCB ASSY (PC Board omitted.)

REF. NO.	PARTS NO.	DESCRIPTION
	5200098800	PCB Assy
	5210098800	PCB
R101, R102	5240034220	Carbon Resistor, 330kM ±5% ¼W
	5300909000	Slide, Switch; 4-2S:SSB-042BQ

KEYBOARD PCB ASSY (PC Board omitted.)

REF. NO.	PARTS NO.	DESCRIPTION
	5200098700	PCB Assy
	5210098700	PCB
S810~S817	5302101600	Tact Switch; J-M0452
S819~S824	5302101600	Tact Switch; J-M0452
D810~D813	5225010500	LED, GL-6HD22
D814, D815	5225005900	LED, SLP-151B

SPEED SWITCH PCB ASSY (PC Board omitted.)

REF. NO.	PARTS NO.	DESCRIPTION
	5200098610	PCB Assy [X-1000M]
	5200098600	PCB Assy [X-1000]
	5210098601	PCB
CONNECTOR PLUGS		
	5122300000	3P (RED)
	5122301000	4P (RED)
	5122129000	5P
	5122132000	8P
MISCELLANEOUS		
	5300018400	Switch, Push; 4-2M
	5300030500	Switch, Push; 3-gang

X-1000M

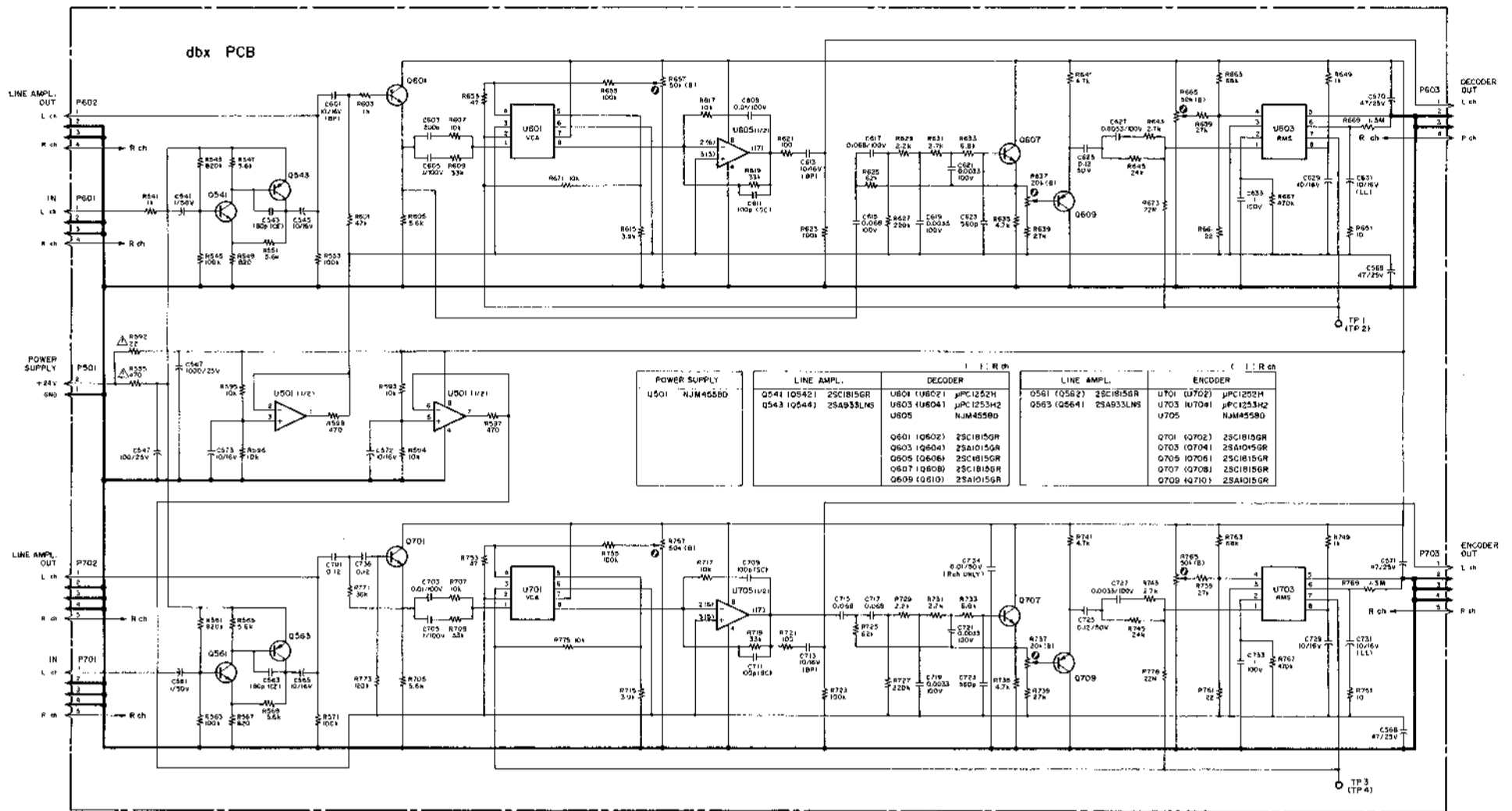

X-1000

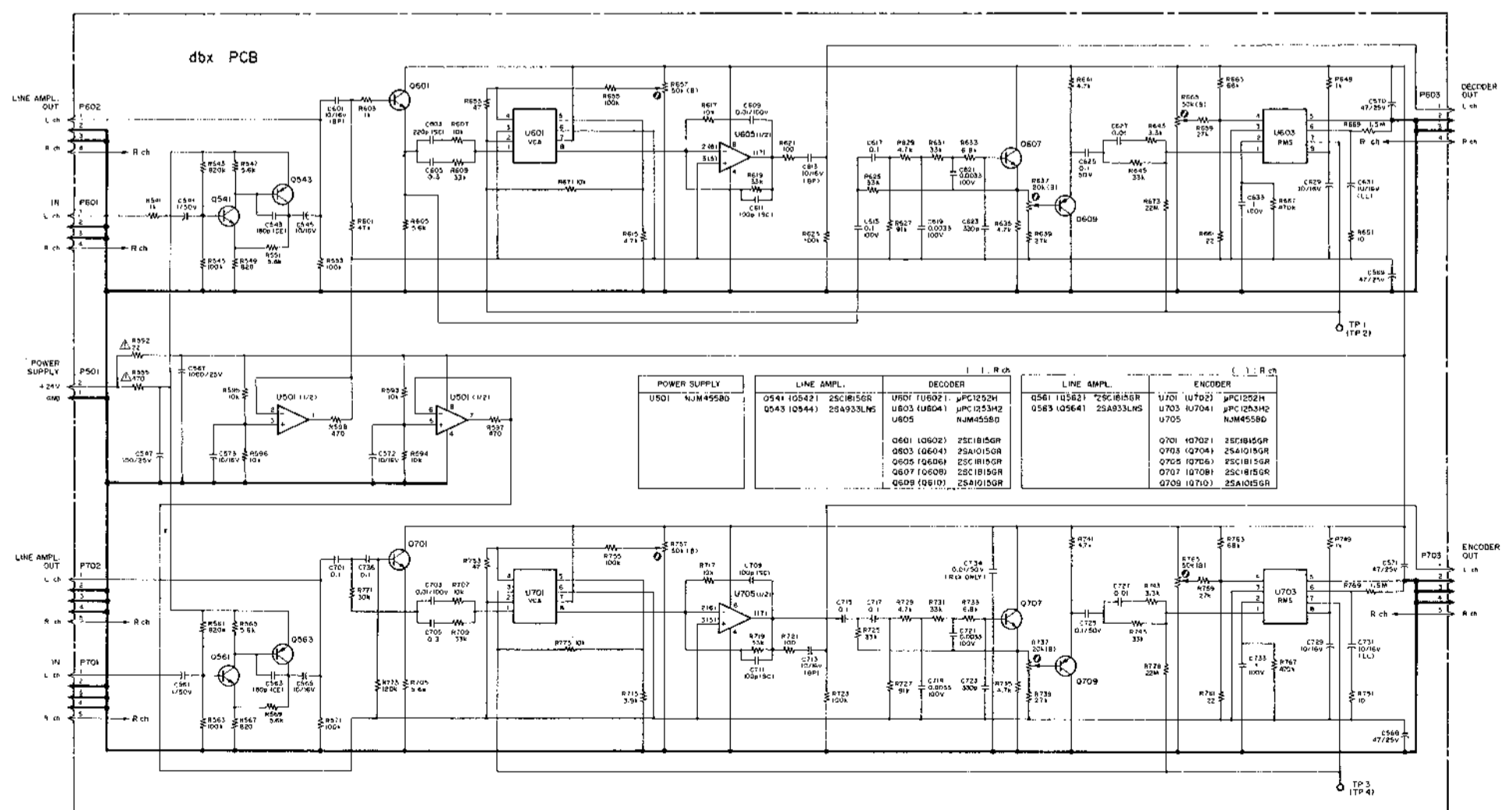

X-1000M/X-1000

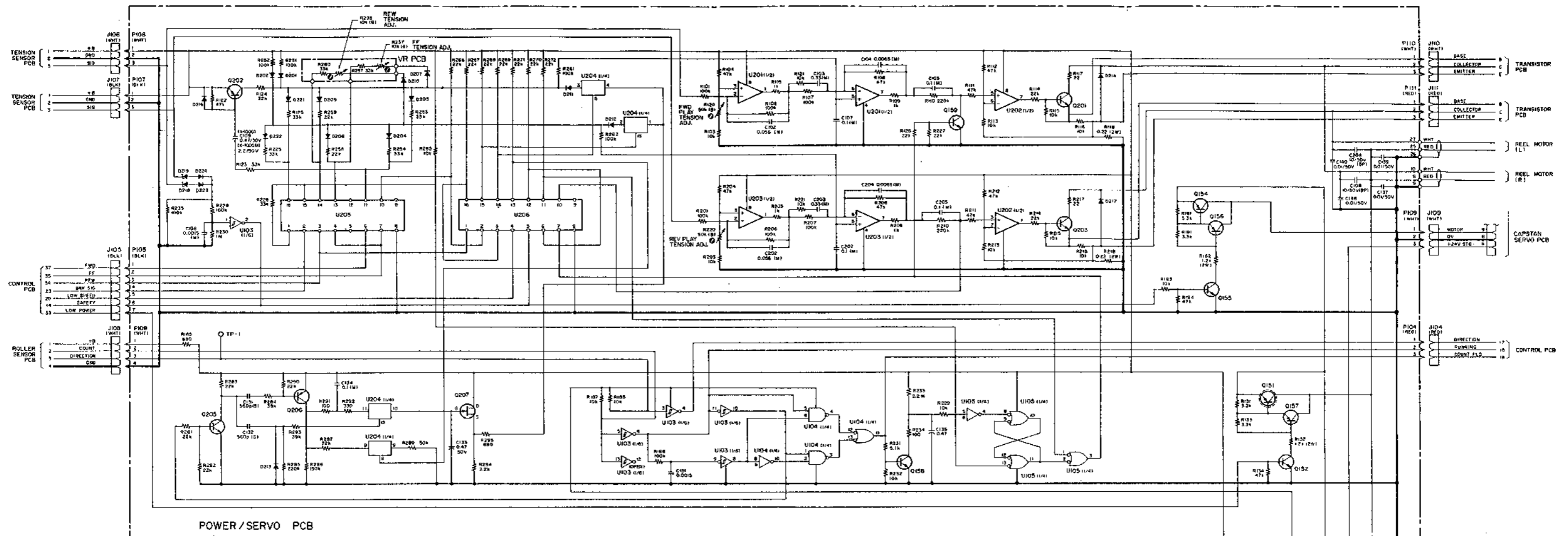

U103	HD14964B	Q102	2SC1318(5)	Q201	2SC1815(1R)	D101 ~ D106	ERB12-0201	D201 ~ D213	1S2473HJ
U104, U105	HD14911B	Q103	2SC536(F)	Q202	2SA1015(1R)	D108, D110	ERB12-02G1	D214, D216	1S2473HJ
		Q104	2SB507(E)	Q203	2SC1815(1R)	D109, D110	ERB12-02G1	D217	1S2473HJ
U201 ~ U203	LM2904N	Q152	2SC1318(5)	Q204	2SA1015(1R)			D218, D219	W250
U204	HD14968B	Q154	2SB507(E)	Q205	2SC1318(5)			Q206	2SA1015(1R)
U205, U206	TD62504P	Q156, Q157	2SA1015(1R)	Q207	2SK68(1A)			Q220	ERB12-02G1
		Q158, Q159	2SC1815(1R)	Q207	2SK68(1A)			D221 ~ D224	1S2473HJ

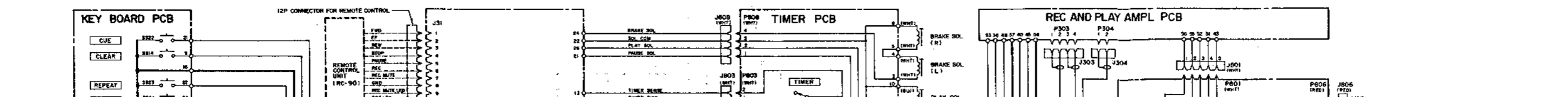
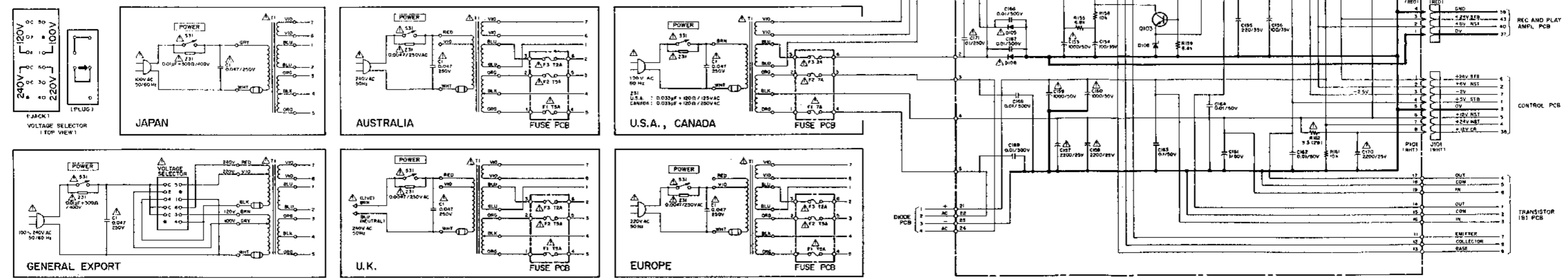

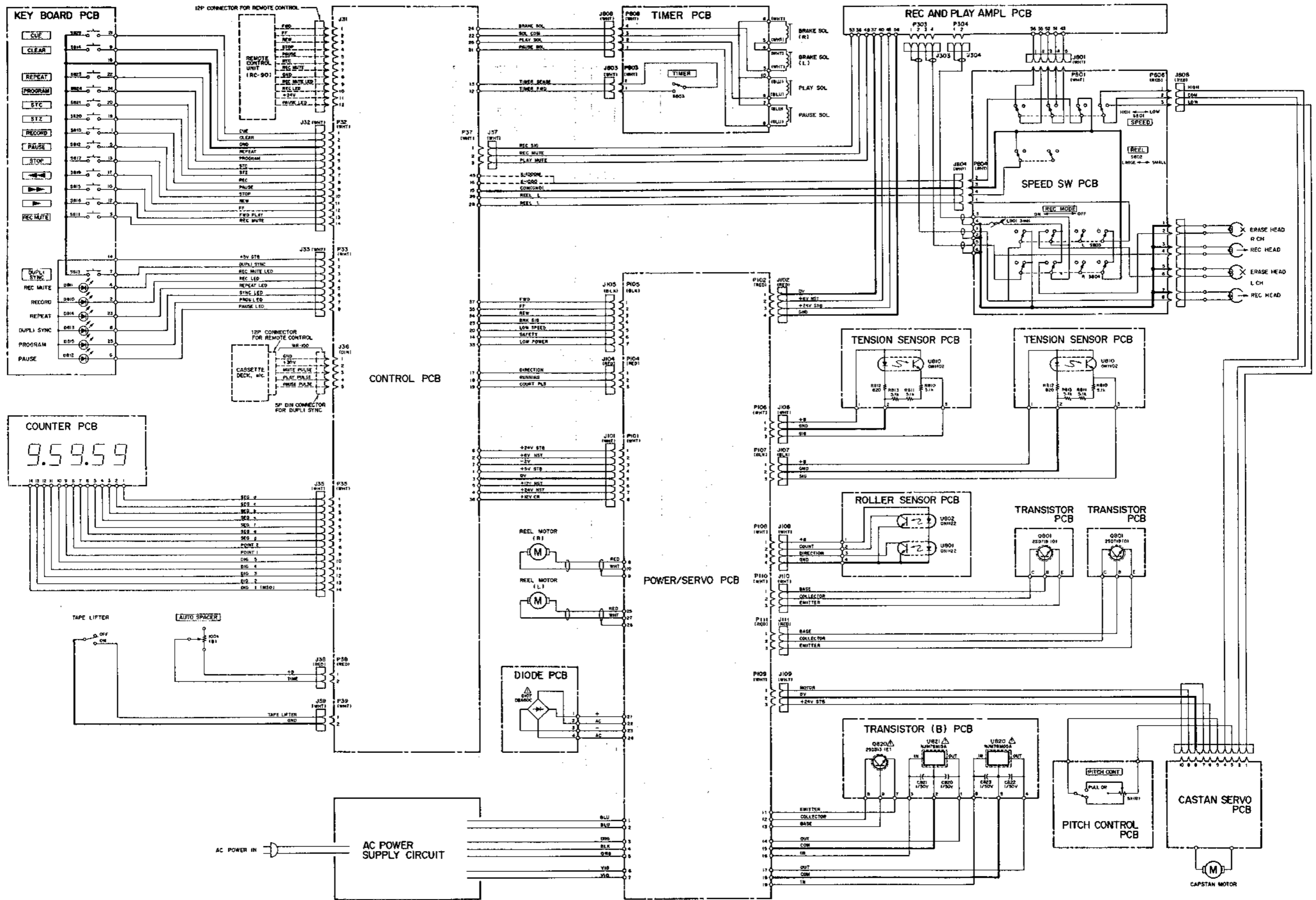

TEAC

Stereo Tape Deck

X-1000M/X-1000

Schematic Diagrams

Diagrammes schématiques

Schematische Diagrammen

Schematische Diagramme

Diagramas Esquemáticos

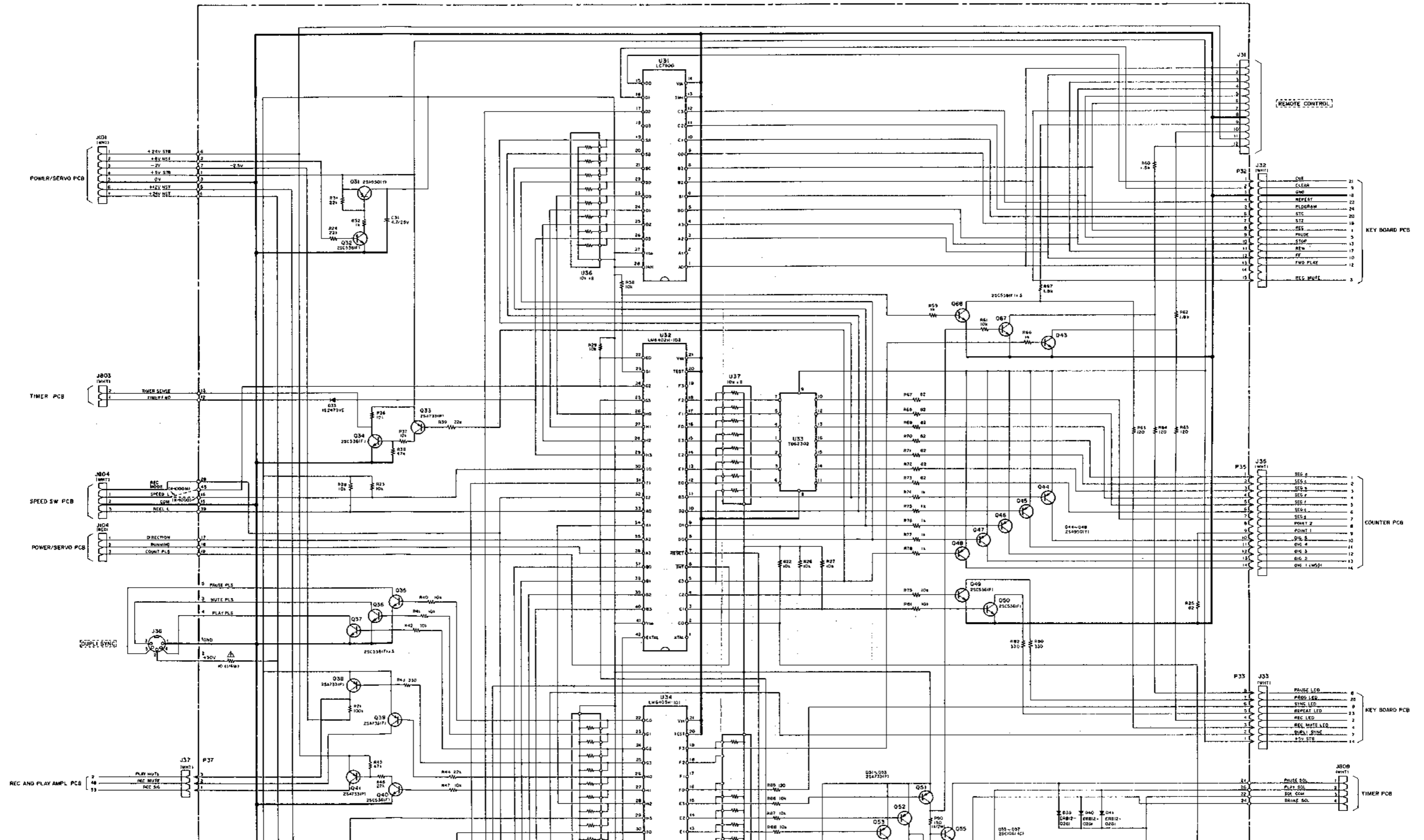

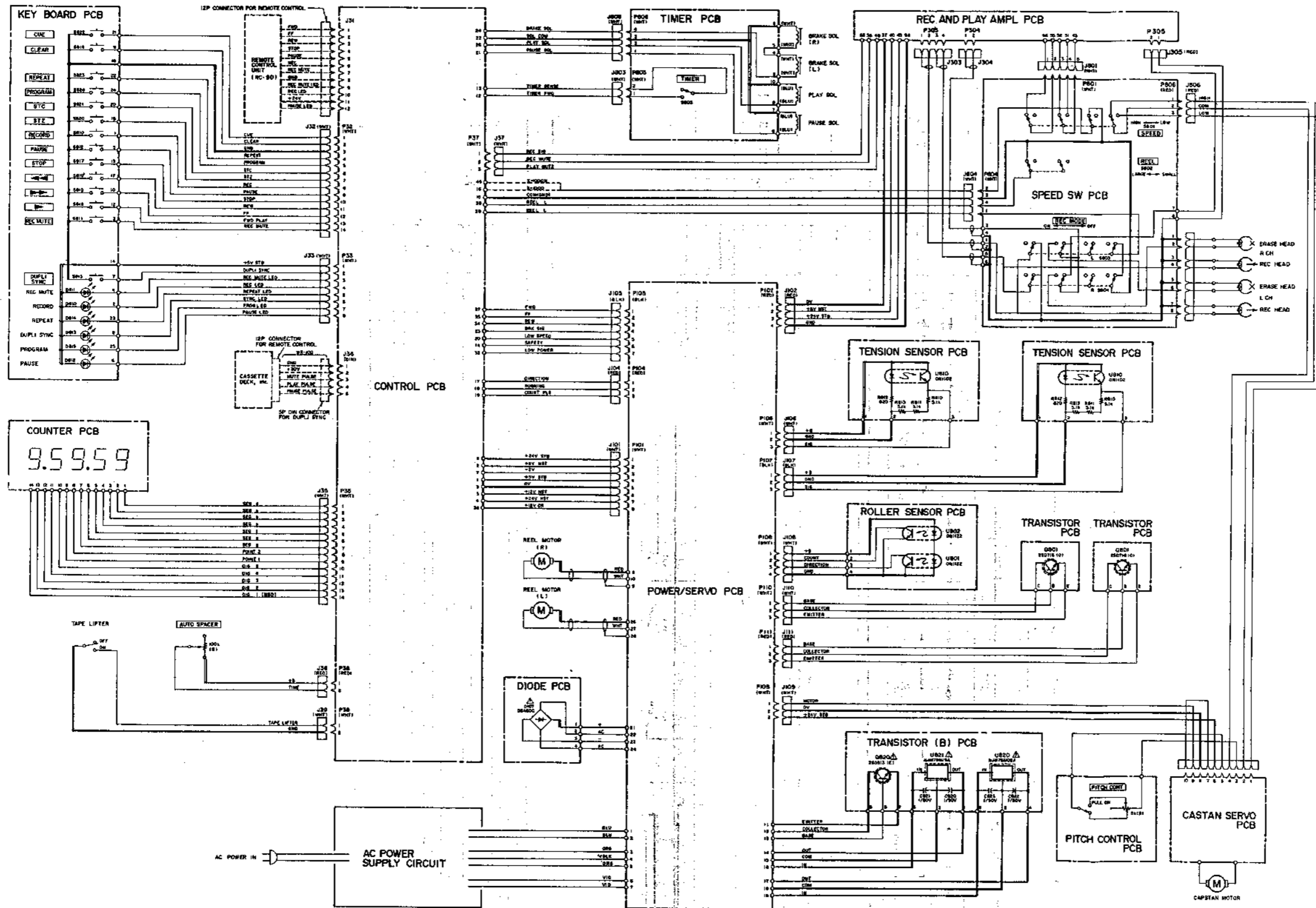

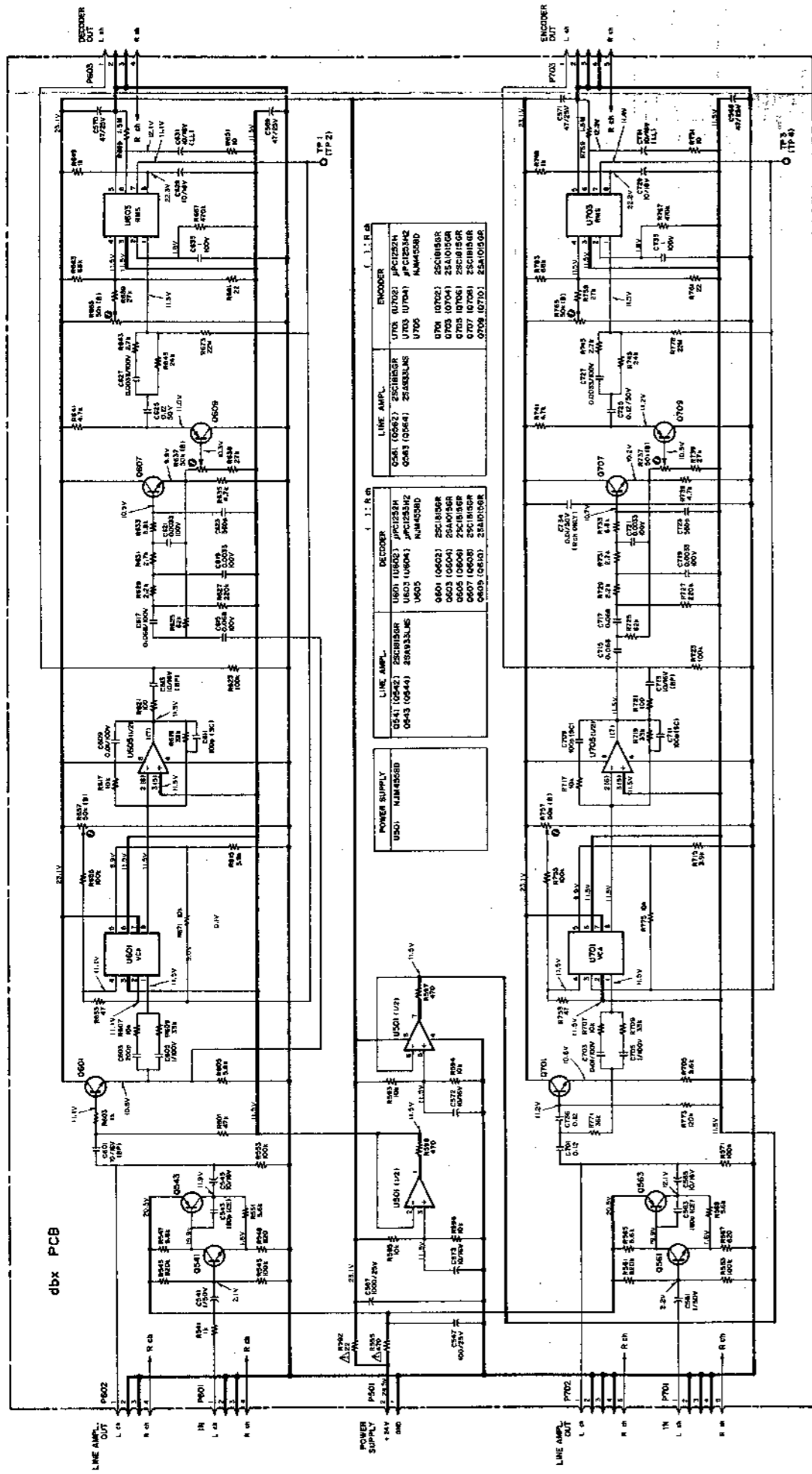

TYPE I (X-1000M)

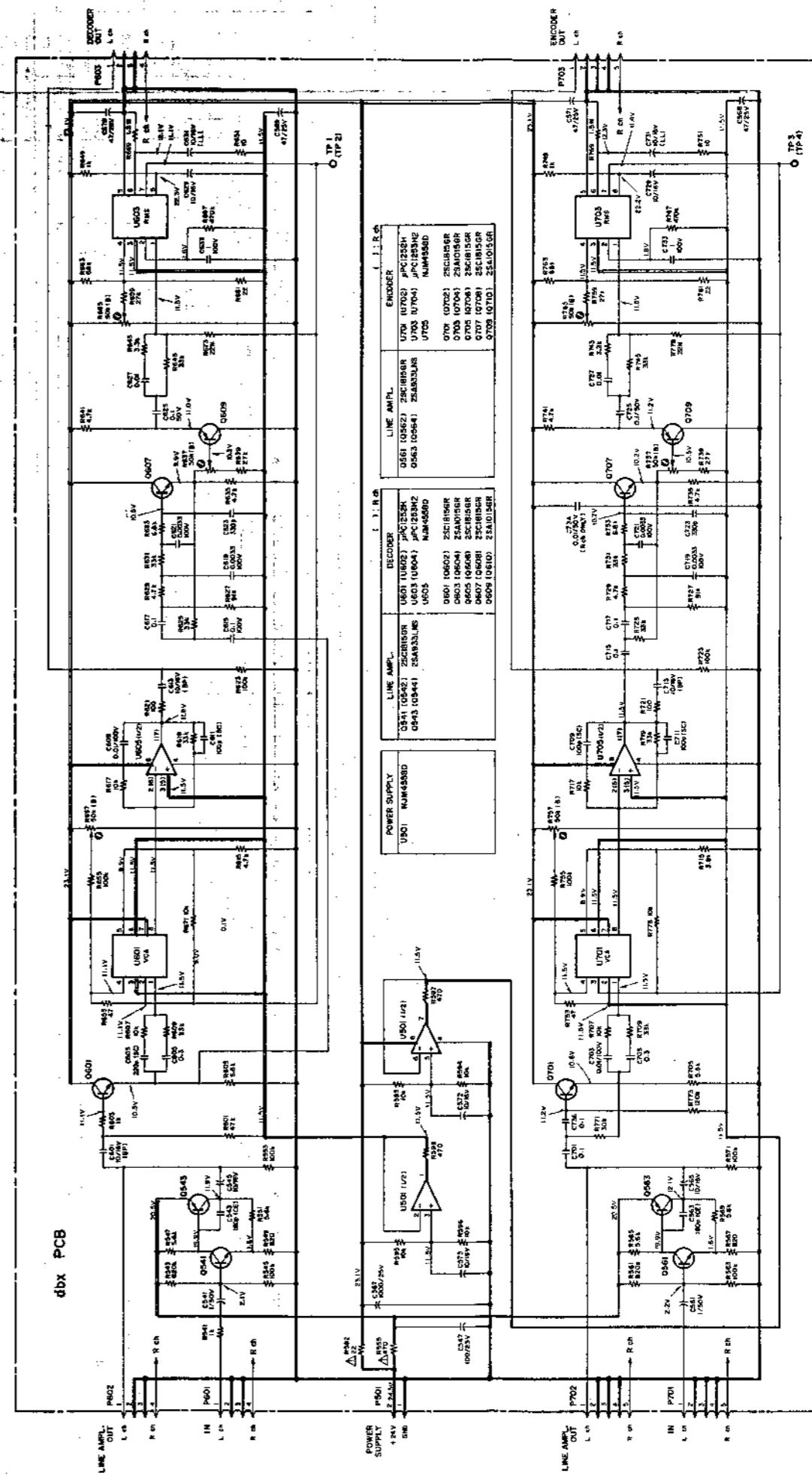

TYPE II (X-1000)

X-1000M/X-1000

Stereo Tape Deck

TEAC SCHEMATIC DIAGRAM X-1000M/X-1000

2

3

4

5

6

7

A

B

C

D

E

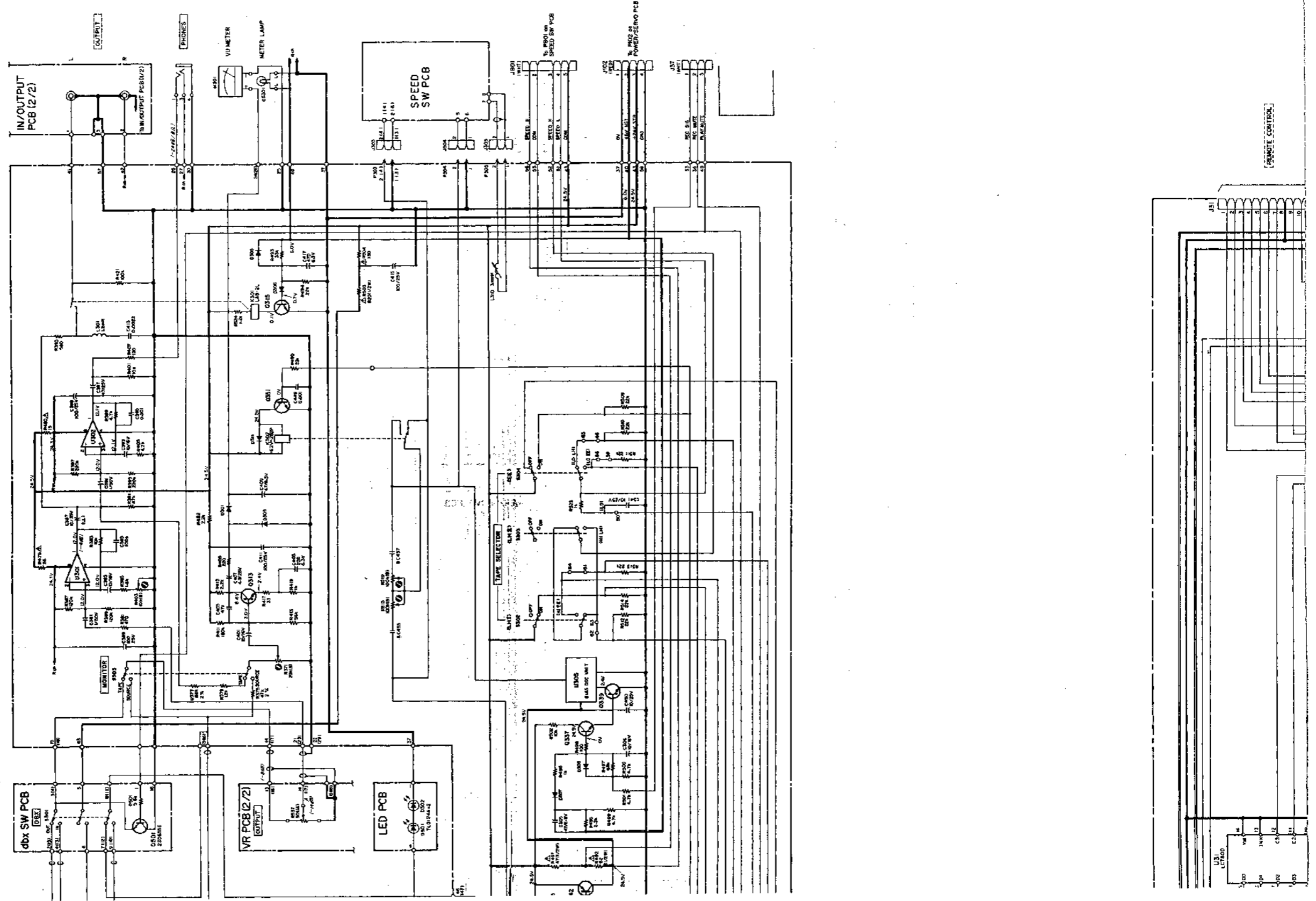

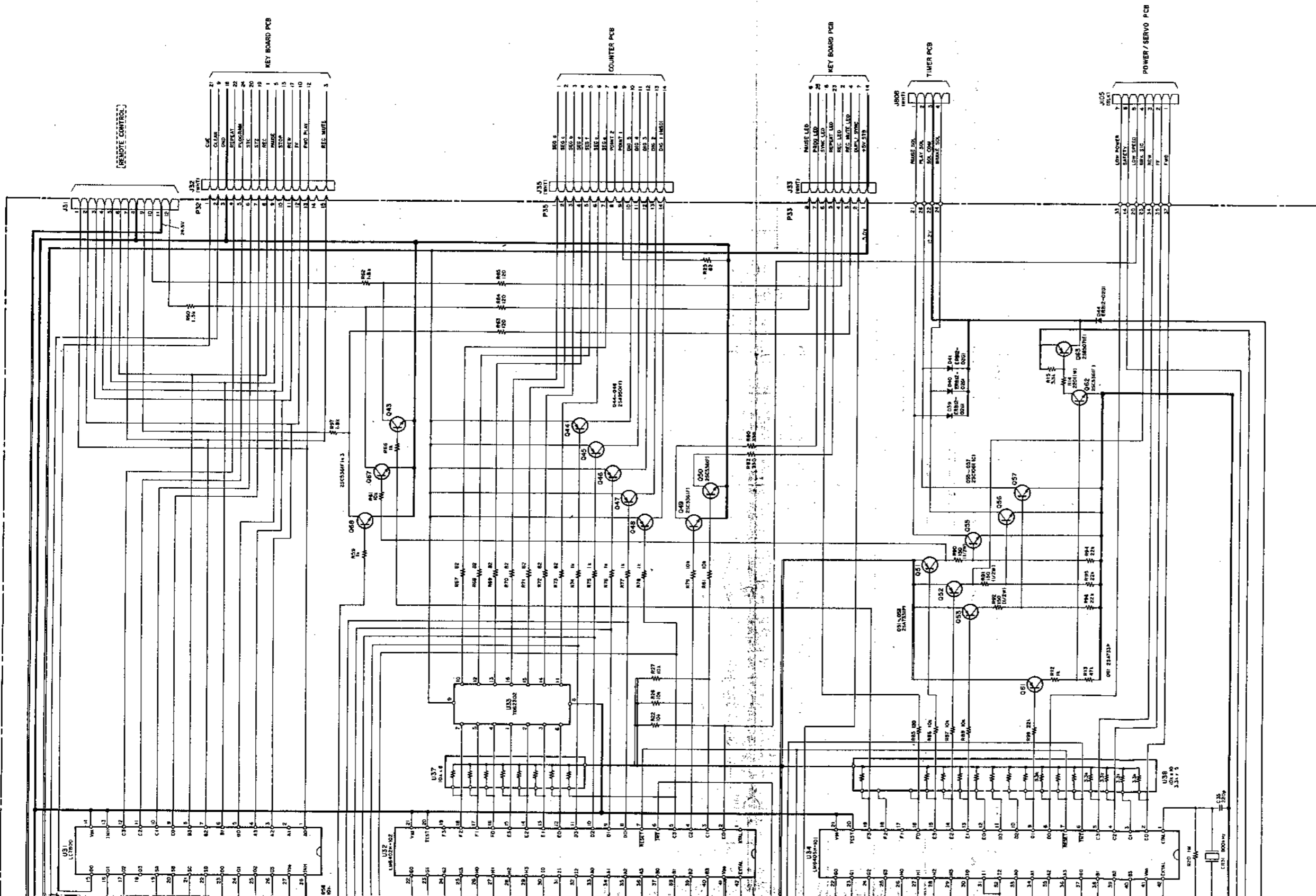

U31	CT600
1	100
2	100
3	100
4	100
5	100
6	100
7	100
8	100
9	100
10	100

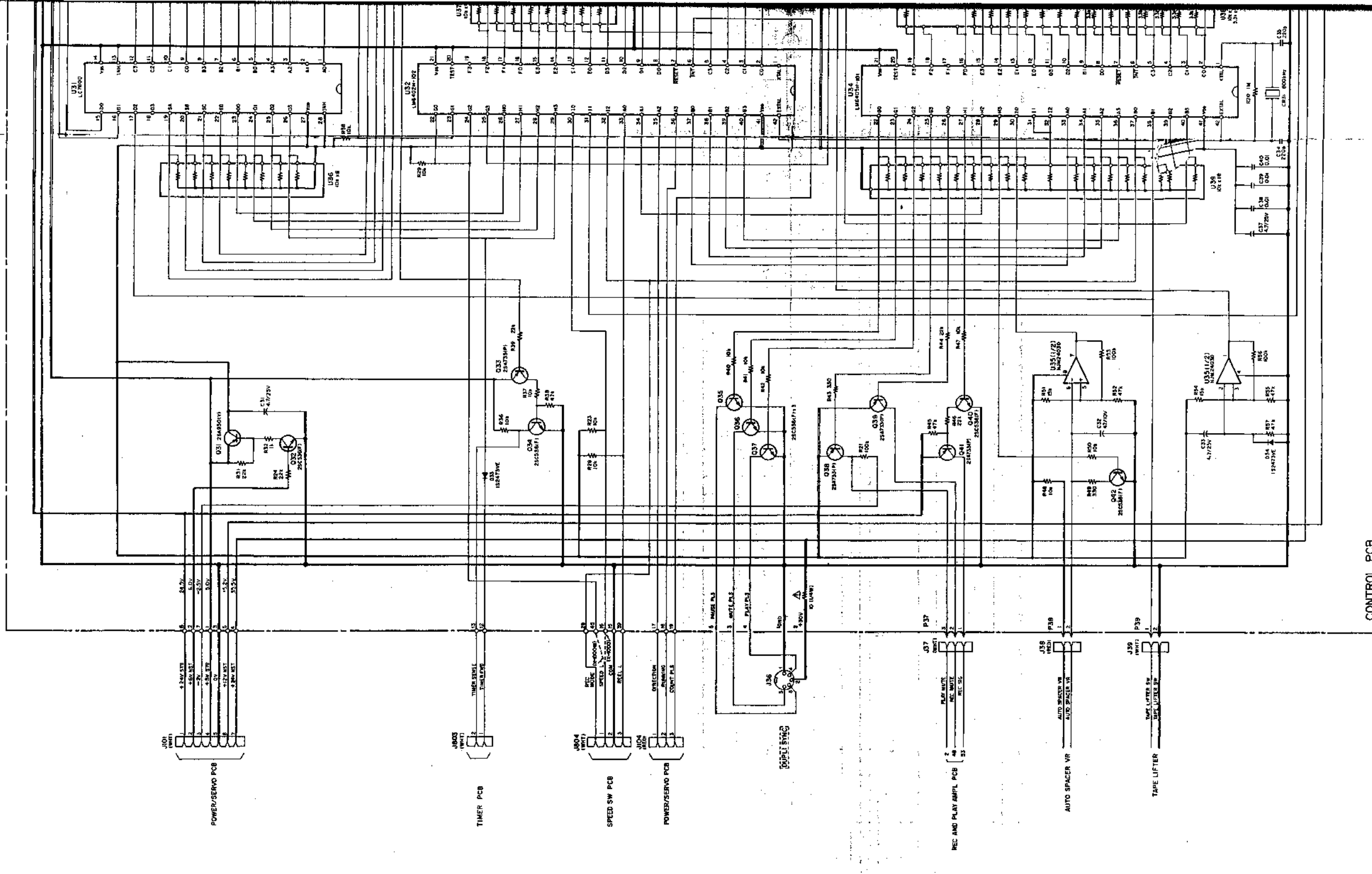



CONTROL PCB

- NOTES
1. Schematic diagram shown for left channel except for some of the components.
 2. All resistors are 1/2 watt, ±5%, unless marked otherwise. Resistor values are in ohms (k = 1,000 ohms).
 3. All capacitor values are in microfarads (p = picofarads).
 4. Δ Parts marked with this sign are safety critical components. They must always be replaced with identical components—refer to the TEAC parts list and ensure exact replacement.
 5. Voltage and level values are for reference only. 0dB = 0.775V. Indicated values are those existing when the meter indicates 0VU.
 6.  : front panel indication.
 7.  : rear panel indication.
 8.  : +B power supply circuit.

X-1000M/X-1000

Stereo Tape Deck

4