

# TEAC

## SERVICE MANUAL

# SL-D90

AM/FM STEREO DIGITAL  
RADIO WITH CD PLAYER



- PC board shown are viewed from parts side.
- The parts with no reference number or no parts number in the exploded views are not supplied.
- As regards the resistors and capacitors, refer to the circuit diagrams contained in this manual.
- ⚠ Parts marked with this sign are safety critical components. they must be replaced with identical components - refer to the appropriate parts list and ensure exact replacement.



<b>1 SAFETY INFORMATION</b> .....	2
<b>2 SPECIFICATIONS</b> .....	3
<b>3 ADJUSTMENT AND CHECKS</b> .....	4
<b>4 EXPLODED VIEW AND PARTS LIST</b> .....	7
<b>5 PC BOARDS AND PARTS LISTS</b> .....	13
<b>6 WIRING DIAGRAM</b> .....	23
<b>7 INCLUDED ACCESSORIES</b> .....	25

# SL-D90

## 1 SAFETY INFORMATION

### SAFETY INFORMATION

This product has been designed and manufactured according to FDA regulations "title 21, CFR, chapter 1, subchapter J, based on the Radiation Control for Health and Safety Act of 1968" and is classified as class 1 laser product. There is not hazardous invisible laser radiation during operation because invisible laser radiation emitted inside of this product is completely confined in the protective housings. The label required in this regulation is shown ①.

• **CAUTION**

USE OF CONTROLS OR ADJUSTMENT OR PERFORMANCE OF PROCEDURES OTHER THAN THOSE SPECIFIED HEREIN MAY RESULT IN HAZARDOUS RADIATION EXPOSURE.

DO NOT REMOVE THE PROTECTIVE HOUSING USING SCREWDRIVER.

IF THIS PRODUCT DEVELOPS TROUBLE, MAKE A CONTACT WITH OUR SERVICEMAN, AND DO NOT USE THE PRODUCT A TROUBLED STATE.

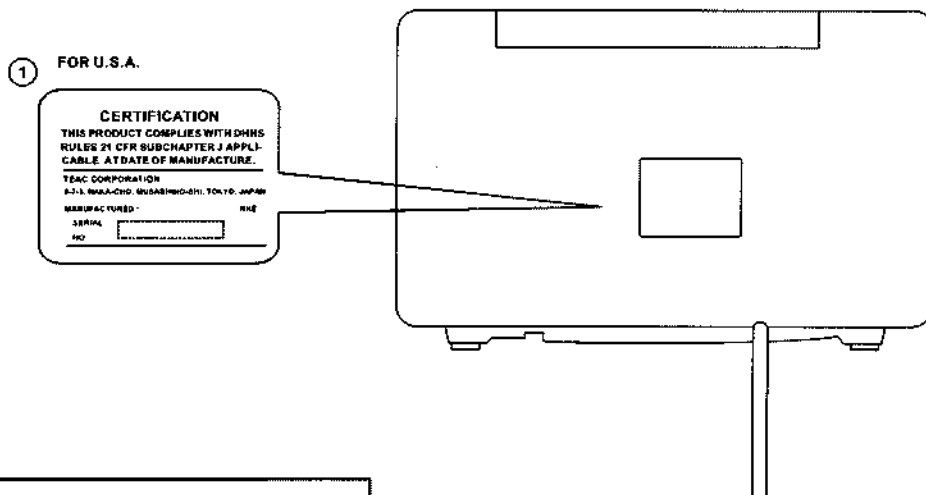

<b>Optical pickup:</b>	
Type	: KSM-213CDM
Manufacturer	: SONY Corporation
Laser output	: Less than 0.5 mW on the objective lens
Wavelength	: 770 -795 nm

## 2 SPECIFICATIONS

### TUNER Section

**Frequency Range (FM):** 87.5MHz to 108.00 MHz

**Frequency Range (AM):** 520kHz to 1710 kHz

### CD PLAYER Section

**Frequency Response:** 20 Hz to 20 kHz (+/- 1dB)

**Wow and Flutter:** Unmeasurable

### SPEAKER SYSTEM Section

**Type:** 1-way

**Impedance:** 8 ohms (L & R)

8 ohms (subwoofer)

### GENERAL

**Power Requirements:** 120V AC, 60Hz (U.S.A./Canada model)

120/230V AC, 50-60Hz (General export model)

**Power Consumption:** 40 W

**Total Output Power :** 20 W

**Dimension (W x H x D):** 340 x 190 x 238.5 mm

(13-3/8 x 7-1/2 x 9-3/8) inches

**Weight:** 5.15 kg (11-3/8 lb)

**Standard Accessories:** Owner's Manual x 1

Warranty Card x 1

Remote Control (RC-858) x 1

FM Lead-type Antenna x 1

- Design and specifications are subject to change without notice.
- Illustrations may differ slightly from production models.

# SL-D90

## 3 ADJUSTMENTS AND CHECKS

### 3-1 TUNER SECTION

- Use a screwdriver with a plastic or ceramic grip for all adjustment.

#### 3-1-1 AM adjustment

1. Set the function switch to the TUNER position.
2. Set the BAND switch to the AM position.
3. Connect the test loop antenna across the output of the signal generator.
4. Connect the oscilloscope to the PHONES JACK terminal.
5. Set the signal generator as listed in the alignment chart.

#### 3-1-2 FM adjustment

1. Set the function switch to the TUNER position.
2. Set the BAND switch to the FM position.
3. Connect the signal generator output through a 75 ohm dummy antenna to (ANT) on TUNER PCB CN8
4. Connect the oscilloscope to the PHONES JACK terminal.
5. Set the signal generator as listed in the alignment chart.

### 3-2 Adjustments and Test Points

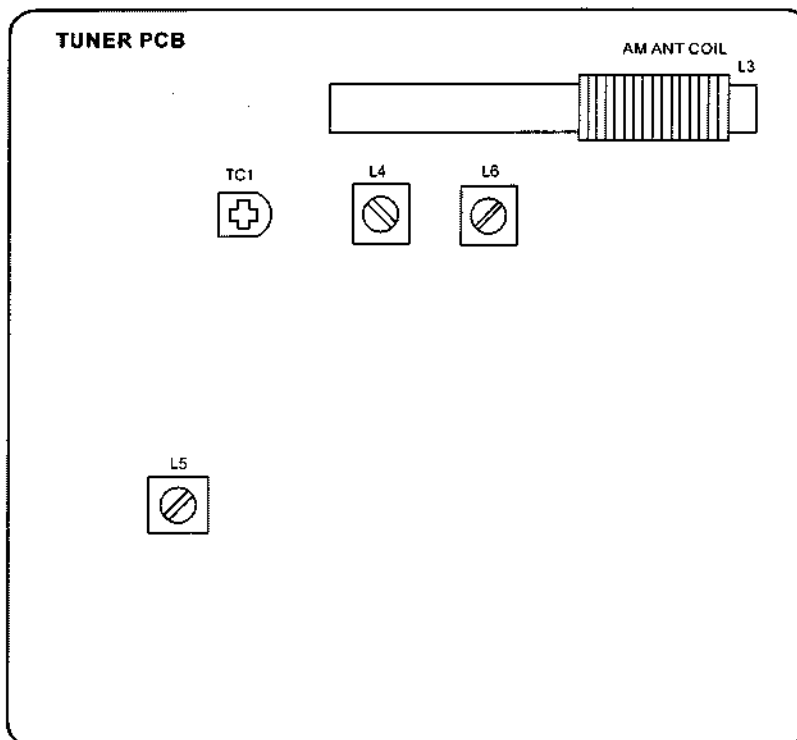

Fig. 3-2-1

## 3-2-2 AM Tuner

ITEM	SIGNAL GENERATOR SETTING				TUNER SETTING	ADJUSTMENTS	MEASURING POINTS, RESULT
	Audio	Modulation	Frequency	Output			
1. VOLTAGE adjustment					1710KHz	L4	VT 8.0V
					530 KHz	Check	VT 1.5V
2. IFT adjustment	1KHz	30%	610KHz	76 dBuV	610KHz	L6	Maximum output level
3. ANT coil adjustment	1KHz	30%	610KHz	76 dBuV	610KHz	AM ant coil L3	Maximum output level
4. TC1 adjustment	1KHz	30%	1410KHz	76 dBuV	1410KHz	TC1 Repeat step 3 and 4	Maximum output level

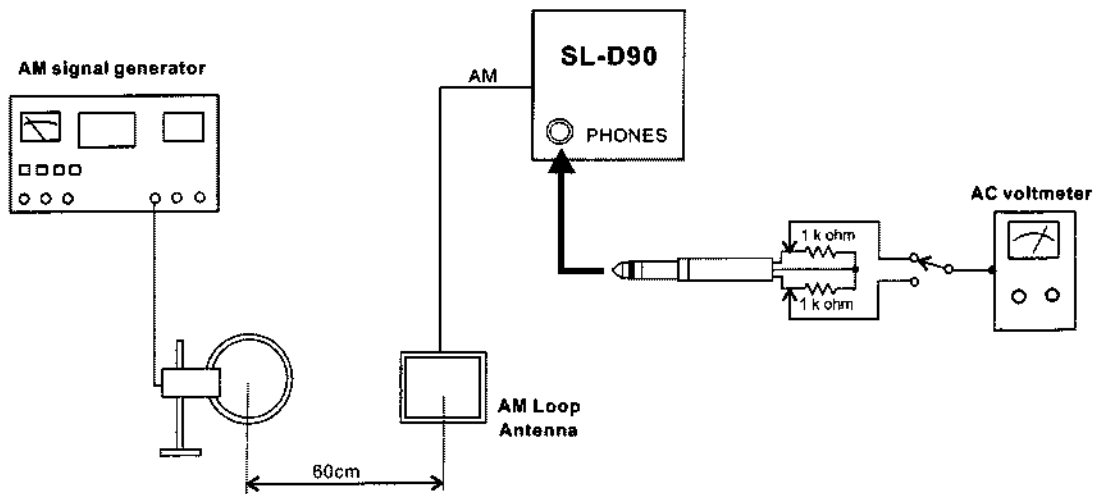

Fig. 3-2-3

# SL-D90

## 3-2-4 FM Tuner

ITEM	SIGNAL GENERATOR SETTING				TUNER SETTING	ADJUSTMENTS	MEASURING POINTS, RESULT
	Audio	Modulation	Frequency	Output			
1. VOLTAGE adjustment					106.1MHz	Check	VT 5.5-5.9V
					90.1MHz	Check	VT 1.2-1.6V
2. IFT adjustment	1KHz	22.5KHz	90.1MHz	25 dBuV	90.1MHz	L5	Maximum output level

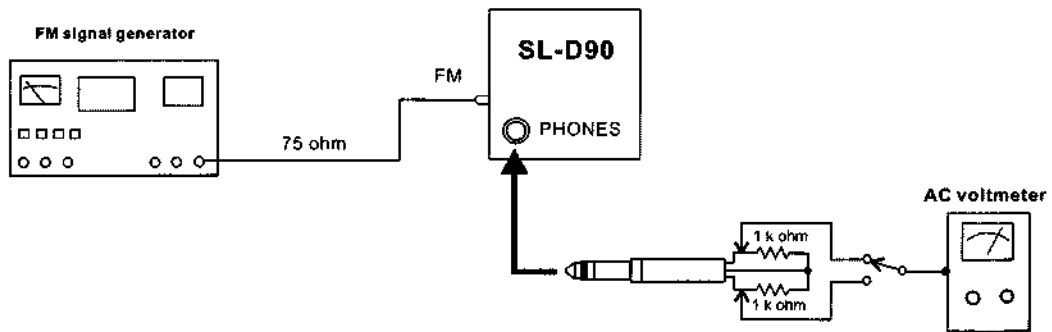
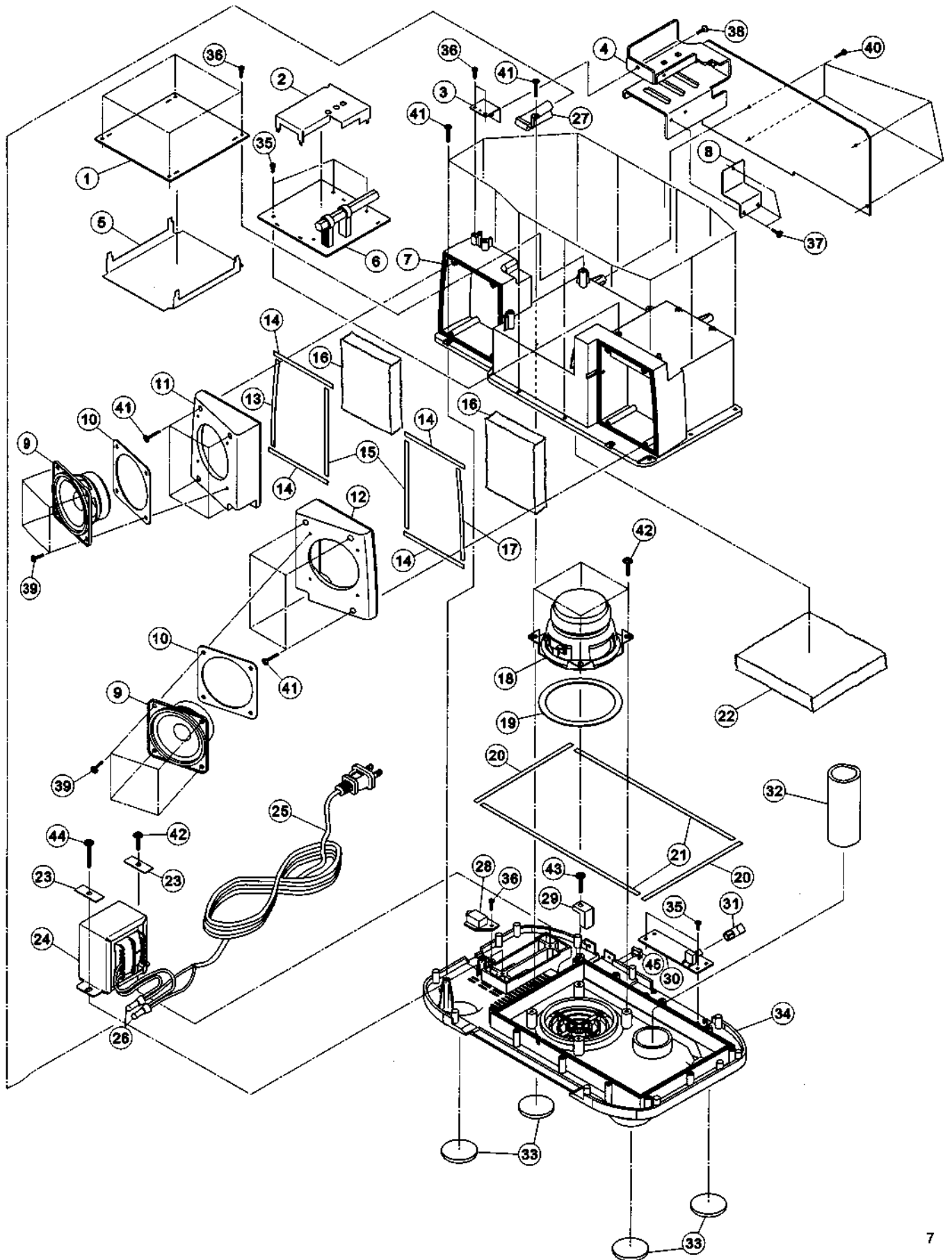

Fig. 3-2-5

# 4 EXPLODED VIEWS AND PARTS LIST

# SL-D90

## EXPLODED VIEW - 1



# SL-D90

## EXPLODED VIEW-1

REF. NO	PARTS NO.	DESCRIPTION	REMARK
1-1	100-SD902030	CD PCB ASSY	
1-2	011-SD900300	TUNER PCB SHIELDPLATE	
1-3	011-SD900200	HEAT SINKBRACKET	
1-4	100-SD902010	MAIN PCB ASSY	
1-5	011-SD900100	CD PCB SHIELDPLATE	
1-6	100-SD902040	TUNER PCB ASSY	
1-7	010-SD900000	SPEAKER BOX	
1-8	015-SD900100	ADIABATIC SHEET	
1-9	061-SD900800	SPEAKER 2(INCHES)	
1-10	035-SD900082	R/L SPEAKER EVA WASHER	
1-11	010-SD900300	L-SPEAKER COVER	
1-12	010-SD900400	R-SPEAKER COVER	
1-13	035-SD900052	EVA SHEET(D)	
1-14	035-SD900042	EVA SHEET(C)	
1-15	035-SD900062	EVA SHEET(E)	
1-16	099-39SLD902	ABSORB COTTON 80x100x20	
1-17	035-SD900072	EVA SHEET(F)	
1-18	061-SD900801	SPEAKER 3(INCHES)	
1-19	035-SD900002	WOOFER SPK EVA WASHER	
1-20	035-SD900032	EVA SHEET(B)	
1-21	035-SD900022	EVA SHEET(A)	
1-22	099-39SLD901	ABSORB COTTON 120x135x20	
1-23	011-SD900400	TRANSFORMER BRACKET	
1-24	△ 084-SD900200	TRANSFORMER (UL/CSA)	
	△ 084-SD900700	TRANSFORMER (ME/UNI)	
	△ 084-SD900300	TRANSFORMER (JIS)	
	△ 084-SD900100	TRANSFORMER (IT/HK)	
1-25	087-00000007	AC CORD UL- (UL/CSA)	
	087-00000027	AC CORD UL- (ME/UNI)	
	087-00000013	AC CORD PSE- (JIS)	
	087-00000001	AC CORD VDE- (IT)	
	087-00000004	AC CORD BSI- (HK)	



## EXPLODED VIEW-1

REF. NO	PARTS NO.	DESCRIPTION	REMARK
1-26	036-00000001	CLOSE END CONNECTOR	
1-27	041-00000004	WIRE CLAMPER W/TUBE	
1-28	100-SD902070	HEAD PHONE JACK ASSY	
1-29	010-SD900600	CORD STOP	
1-30	100-SD902050	AUX PCB ASSY	
1-31	004-SD900700	BASE KNOB	
1-32	044-SLD90040	SPEAKER PAPER TUBE	
1-33	037-SD900000	RUBBER FOOT	
1-34	001-SD900200	BOTTOM PANEL-RED (UL/CSA/JIS/IT/HK)	
	001-SD900201	BOTTOM PANEL-WHITE (UL/CSA/JIS/IT/HK)	
	001-SD900202	BOTTOM PANEL-JADE (UL/CSA/JIS/IT/HK)	
	001-SD900203	BOTTOM PANEL-BLACK (UL/CSA/JIS/IT/HK)	
	001-SD900204	BOTTOM PANEL-RED (ME/UNI)	
	001-SD900205	BOTTOM PANEL-WHITE (ME/UNI)	
	001-SD900206	BOTTOM PANEL-JADE (ME/UNI)	
	001-SD900207	BOTTOM PANEL-BLACK (ME/UNI)	
1-35	021-13006032	SCREW 3x6MM PTZMC HD	
1-36	021-13008032	SCREW 3x8MM PTZMC HD	
1-37	024-23008032	SCREW 3x8MM BAZMC HD	
1-38	022-23008033	SCREW 3x8MM BMBLACK HD	
1-39	024-43010033	SCREW 3x10MM PWA BLACK HD	
1-40	021-13010032	SCREW 3x10MM PTZMC HD	
1-41	021-23014033	SCREW 3x14MM BTBLACK HD	
1-42	021-44010032	SCREW 4x10MM PWTZMC HD	
1-43	021-44012032	SCREW 4x12MM PWTZMC HD	
1-44	021-44018032	SCREW 4x18MM PWTZMC HD	
1-45	 063-GF480300	AC POWER SLIDSWITCH (ME/UNI)	

# SL-D90

## EXPLODED VIEW - 2

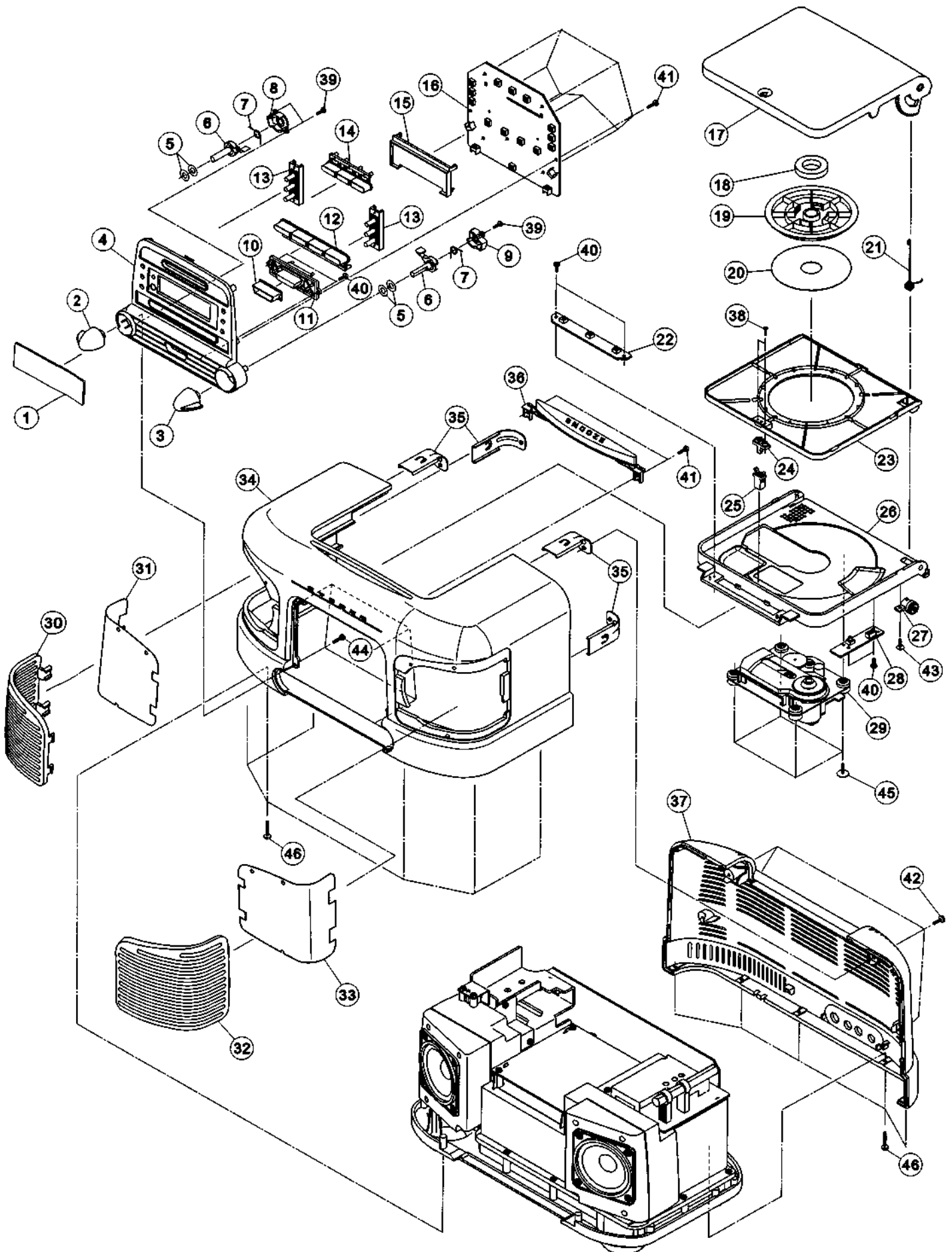

## EXPLODED VIEW-2

REF. NO	PARTS NO.	DESCRIPTION	REMARK
2-1	007-SD900100	LCD DISPLAY WINDOW	
2-2	004-SD900100	VOLUME KNOB	
2-3	004-SD900200	TUNER KNOB	
2-4	001-SD900300	CONTROL PANEL	
2-5	012-02120612	PVC WASHER	
2-6	009-28000000	TUNER/VOLUME SW. LEVER	
2-7	031-28000010	VOLUME SPRING	
2-8	010-SD900700	VOLUME SPRING COVER	
2-9	010-SD900800	TUNER SPRING COVER	
2-10	010-SD901500	POWER KNOB CAP	
2-11	004-SD900300	POWER KNOB	
2-12	004-SD900500	CD CONTROL KNOB	
2-13	004-SD900600	FUNCTION ROUND KNOB	
2-14	004-SD900400	FUNCTION KNOB	
2-15	010-SD901300	LCD BACK LIGHT HOLDER	
2-16	100-SD902020	CONTROL PCB ASSY	
2-17	006-SD900000	CD DOOR - RED	
	006-SD900001	CD DOOR - WHITE	
	006-SD900002	CD DOOR - JADE	
	006-SD900003	CD DOOR - BLACK	
2-18	052-SD900000	CD MAGNET	
2-19	010-SD900500	CD CLAMPER	
2-20	051-SD900000	CD CLAMPER HIMERON(A)	
2-21	031-SD900010	CD DOOR SPRING	
2-22	100-SD902080	SNOOZE PCB ASSY	
2-23	006-SD900100	CD DOOR COVER- RED	
	006-SD900101	CD DOOR COVER- WHITE	
	006-SD900102	CD DOOR COVER- JADE	
	006-SD900103	CD DOOR COVER- BLACK	
2-24	010-SD901100	CD DOOR CATCH - RED	
	010-SD901101	CD DOOR CATCH - WHITE	
	010-SD901102	CD DOOR CATCH - JADE	
	010-SD901103	CD DOOR CATCH - BLACK	
2-25	010-SD901200	CD DOOR LOCK	
2-26	002-SD900000	CD BASE	
2-27	008-0GP18000	GEAR DUMPER ASSY	
2-28	100-SD902060	CD SWITCH PCB ASSY	
2-29	039-SD901210	CD MECHA	
2-30	010-SD900100	L-SPEAKER GRILL	
2-31	051-SD900002	SPEAKER NET HIMERON(L)	
2-32	010-SD900200	R-SPEAKER GRILL	
2-33	051-SD900003	SPEAKER NET HIMERON(R)	

# SL-D90

## EXPLODED VIEW-2

REF. NO	PARTS NO.	DESCRIPTION	REMARK
2-34	001-SD900000	FRONT PANEL-RED(UL/CSA/ME/UNI/IT/HK)	
	001-SD900001	FRONT PANEL-WHITE (UL/CSA/ME/UNI/IT/HK)	
	001-SD900002	FRONT PANEL-JADE(UL/CSA/ME/UNI/IT/HK)	
	001-SD900003	FRONT PANEL-BLACK(UL/CSA/ME/UNI/IT/HK)	
	001-SD900005	FRONT PANEL-RED(JIS)	
	001-SD900006	FRONT PANEL-WHITE (JIS)	
	001-SD900007	FRONT PANEL-JADE (JIS)	
	001-SD900008	FRONT PANEL-BLACK(JIS)	
2-35	011-SD900000	PANEL BRACKET	
2-36	004-SD900000	SNOOZE KNOB - RED	
	004-SD900001	SNOOZE KNOB - WHITE	
	004-SD900002	SNOOZE KNOB - JADE	
	004-SD900003	SNOOZE KNOB - BLACK	
2-37	001-SD900100	BACK PANEL-RED(UL/CSA)	
	001-SD900101	BACK PANEL-WHITE (UL/CSA)	
	001-SD900102	BACK PANEL-JADE (UL/CSA)	
	001-SD900103	BACK PANEL-BLACK(UL/CSA)	
	001-SD900104	BACK PANEL-RED (ME/UNI)	
	001-SD900105	BACK PANEL-WHITE (ME/UNI)	
	001-SD900106	BACK PANEL-JADE (ME/UNI)	
	001-SD900107	BACK PANEL-BLACK (ME/UNI)	
	001-SD900108	BACK PANEL-RED (JIS)	
	001-SD900109	BACK PANEL-WHITE (JIS)	
	001-SD900110	BACK PANEL-JADE (JIS)	
	001-SD900111	BACK PANEL-BLACK (JIS)	
	001-SD900112	BACK PANEL-RED (IT)	
	001-SD900113	BACK PANEL-WHITE (IT)	
	001-SD900114	BACK PANEL-JADE (IT)	
	001-SD900115	BACK PANEL-BLACK (IT)	
	001-SD900116	BACK PANEL-RED (HK)	
	001-SD900117	BACK PANEL-WHITE (HK)	
	001-SD900118	BACK PANEL-JADE (HK)	
	001-SD900119	BACK PANEL-BLACK (HK)	
2-38	021-42006032	SCREW 2x6MM PWT ZMC HD	
2-39	023-12606032	SCREW 2.6x6MM PB ZMC HD	
2-40	021-13006032	SCREW 3x6MM PT ZMC HD	
2-41	021-13008032	SCREW 3x8MM PT ZMC HD	
2-42	022-23008033	SCREW 3x8MM BMBLACK HD	
2-43	021-43008033	SCREW 3x8MM PWT BLACK HD	
2-44	021-13010032	SCREW 3x10MM PT ZMC HD	
2-45	021-43010032	SCREW 3x10MM PWT ZMC HD	
2-46	021-23014033	SCREW 3x14MM BTBLACK HD	

## 5 PC BOARDS AND PARTS LIST

## MAIN PCB ASSY

REF. NO	PARTS NO.	DESCRIPTION	REMARK
	100-SD902010	MAIN PCB ASSY	
	062-SLD90000	MAIN PCB	
C64,67,68	△ 072-30100251	CE, 25V 1000UF	
C9	△ 072-30220251	CE, 25V 2200UF	
C12	△ 072-30470251	CE, 25V 4700UF	
CN1	082-10440100	CONNECTOR 4P P=2.5MM	
CN2	082-10340100	CONNECTOR 3PIN P=2.5MM	
CN3	082-10300100	CONNECTOR 3PIN P=2MM	
CN4	082-10240100	CONNECTOR 2PIN P=2.5MM	
CN6	082-20500100	CONNECTOR 5PIN P=2MM	
CN7	082-20300100	CONNECTOR 3PIN P=2MM	
CN11,19	082-20540100	CONNECTOR 5PIN P=2.5MM	
CN15	082-21250100	CONNECTOR 12PIN P=1.25MM	
D1-4	△ 077-10539201	DIODE IN5392	
D5-8	077-10400201	DIODE IN4002	
D9-15,22	077-00414801	DIODE IN4148	
FUSE01,02	△ 090-22520022	FUSE T2AL 250V(ME/UN/IT/HK)	
	△ 090-22520023	FUSE SLA 2A250V (UL/CSA/JIS)	
IC3	075-00405201	IC-TC4052BP	
IC4	075-00926001	IC-TC9260P	
IC5,6	075-01521808	IC-BA15218	
IC7	075-00821841	IC-TA8218AH	
IC8	075-00780801	IC-AN7808	
IC12	075-00780501	IC-KIA7805PI	
L1	078-06301952	FM COIL Ø3x19.5Tx0.5MM	
Q1,2,4,5,8, Q12-18,31,32	076-00C94500	TR-2SC945	
Q3	076-C2001L00	TR-2SC2001L	
Q6,9	076-00A73300	TR-2SA733	
Q7	076-00B54400	TR-2SB544F	
ZD1	077-3011B20H	ZENER DIODE 10VHZ11B2	

# SL-D90

## MAIN PCB

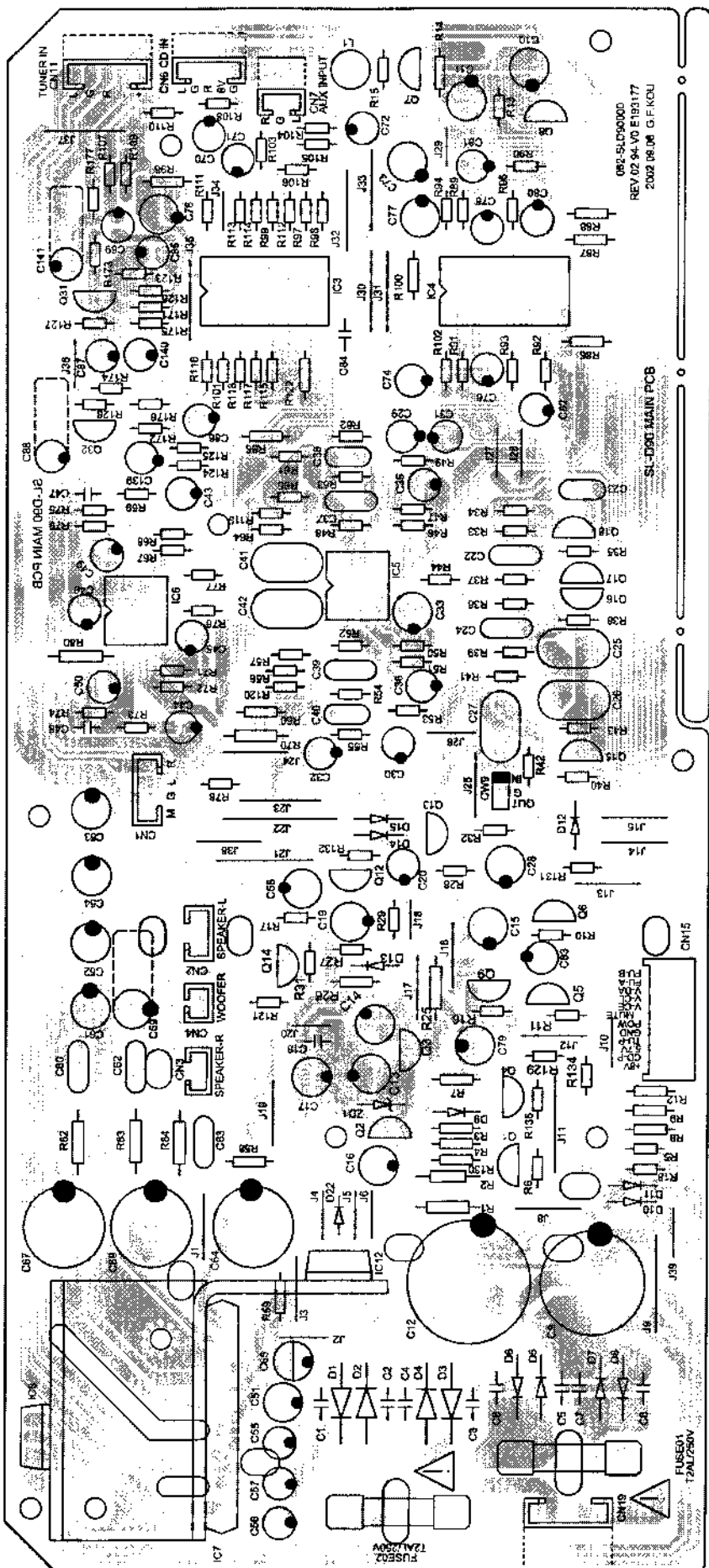

082-SL-D90000  
REV 02 94-V0 E13177  
2002 06/06 G.F.KOU

SL-D90 MAIN PCB

FUSE01  
12AL250V

## CD PCB ASSY

REF. NO	PARTS NO.	DESCRIPTION	REMARK
	100-SD902030	CD PCB ASSY	
	062-SLD90002	CD PCB	
C230	 072-30220101	CE, 10V 2200UF	
CN5	082-21250100	CONNECTOR 12PIN P=1.25MM	
CN12	082-23050100	CONNECTOR 30PIN P=1.25MM	
CN16	082-20400100	CONNECTOR 4PIN P=2MM	
CN17	082-10600100	CONNECTOR 6PIN P=2MM	
CN18	082-21600305	CONNECTOR 16PIN P=1MM	
D201-206	077-00414801	DIODE IN4148	
IC9	075-094A0931	IC-TC94A09F-202	
IC10	075-00209001	IC-TA2092N	
IC11	075-00215301	IC-TA2153FN	
L9,10	095-00100001	INDUCTOR 10UH	
Q201	076-00B54400	TR-2SB544F	
Q202	076-00A73300	TR-2SA733	
Q203	076-00C94500	TR-2SC945	
XT2	093-A0750002	CRYSTAL 75KHZ	
XT3	093-11693440	CRYSTAL 16.9344MHZ	





## TUNER PCB ASSY

REF. NO	PARTS NO.	DESCRIPTION	REMARK
	100-SD902040	TUNER PCB ASSY	
	062-SLD90003	TUNER PCB	
	056-10080001	FERRITER BAR D10x80MM	
CF1,CF2	081-31070001	AM FILTERL10.7MA5-A	
CF3	081-04500000	FM FILTERSFU450B	
CN10	082-10600100	CONNECTOR 6PIN P=2MM	
D16-21	077-00414801	DIODE IN4148	
F001	054-0GP18000	FM ANT FILTER GFMB3	
IC1	075-00145008	IC-BA1450S	
IC2	075-09257F21	IC-TC9257F	
L2	095-10220001	INDUCTOR 220UH	
L3	096-SLD90010	AM ANT COIL 66T:14T	
L4	079-D2930210	AM OSC COIL - RED	
L5	079-SLD90020	FM DET COIL - BLACK	
L6	079-SLD90410	AM IFT COIL - YELLOW	
Q27	076-00A73300	TR-2SA733	
Q28,29,30	076-00C94500	TR-2SC945	
T001	055-SLD90000	TUNER PACK -(UL/CSA/ME/UNI/IT/HK)	
	055-SLD90001	TUNER PACK - (JIS)	
TC1	073-00010022	TRIMMER 10P	
VD1,2	077-50014901	DIODE ISV149	
XT1	093-04500000	CRYSTAL 4.5MHZ	
ZD3	077-3005B20H	ZENER DIODE 5.2VHZ5B2	

# SL-D90

## TUNER PCB

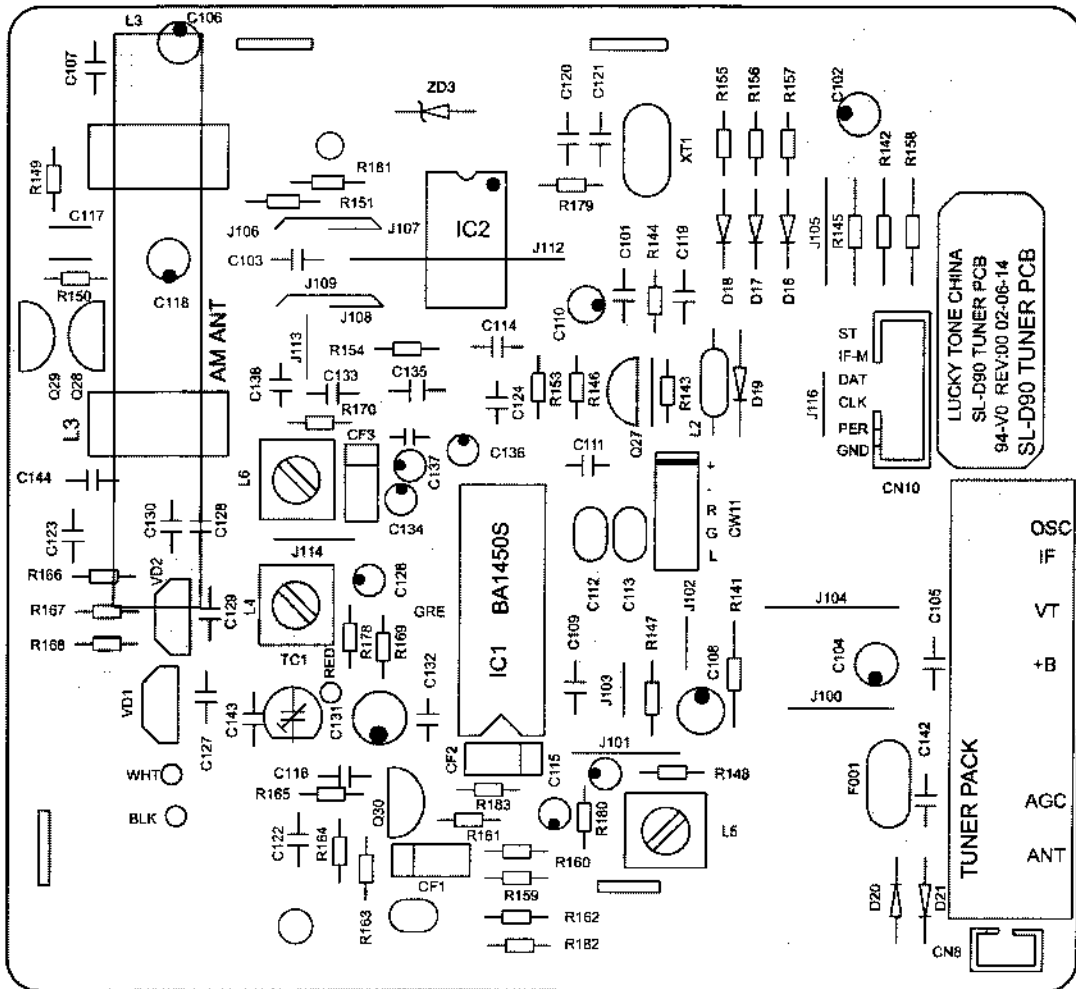

## CONTROL PCB ASSY

REF. NO	PARTS NO.	DESCRIPTION	REMARK
	100-SD902020	CONTROL PCB ASSY	
	062-SLD90001	CONTROL PCB	
LCD1	080-SLD90021	LCD DISPLAY	
LED01,03	094-03020301	LED 3MM-ORANGE	
Q301-304	076-00C94500	TR-2SC945	
SW01,04-10,012, SW014-018	063-0GP28020	TACH SWH=5MM	
SW02,03,011,013	063-D2800020	TACH SWSKHHALM	

# SL-D90

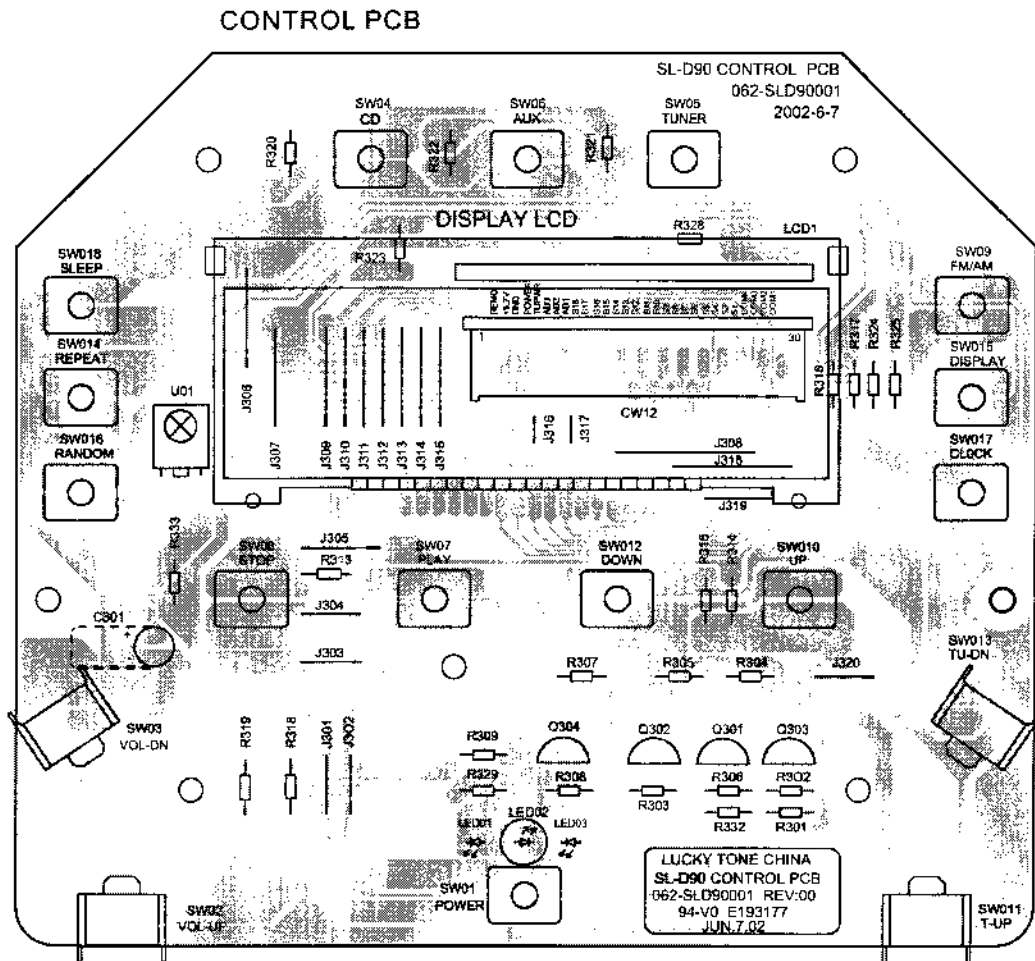

## SNOOZE PCB ASSY

REF. NO	PARTS NO.	DESCRIPTION	REMARK
	100-SD902080	SNOOZE PCB ASSY SNOOZE PCB	
SW019.021	063-SLD90000	TACH SWH=4.3MM	
SW020	063-SLD90001	TACH SWH=5MM	

## AUX PCB ASSY

REF. NO	PARTS NO.	DESCRIPTION	REMARK
	100-SD902050	AUX PCB ASSY AUX PCB	
CN9	082-10300100	CONNECTOR 3PIN P=2MM	
JK02	086-SLD90020	AUX JACK RJ-1095	
VR1	069-SD901000	VOLUME 50KB+C	

## CD SWITCH PCB ASSY

REF. NO	PARTS NO.	DESCRIPTION	REMARK
	100-SD902060	CD SWITCH PCB ASSY CD SWITCH PCB	
SW022	063-SLD80400	CD DOOR ON/OFF SW	
SW023	063-SLD80800	TACH SWH=7.5MM	

## PHONE JACK PCB ASSY

REF. NO	PARTS NO.	DESCRIPTION	REMARK
	100-SD902070	PHONE JACK PCB ASSY PHONE JACK PCB	
JK01	064-35020101	HEAD PHONE JACK 3.5MM	

# SL-D90

## SNOOZE PCB

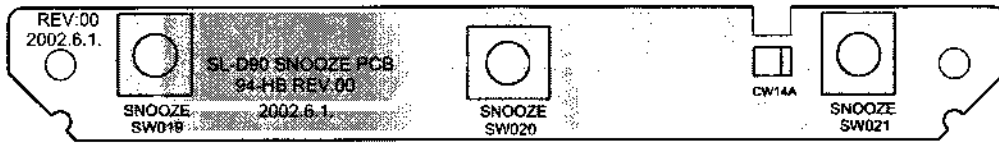

## AUX PCB

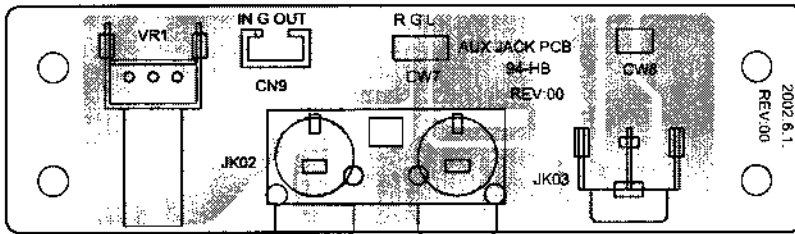

## CD SWITCH PCB

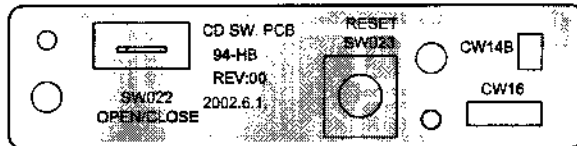

## PHONE JACK PCB

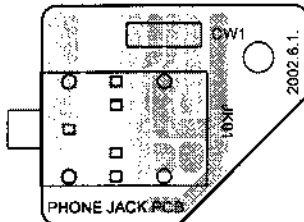

6 WIRING DIAGRAM

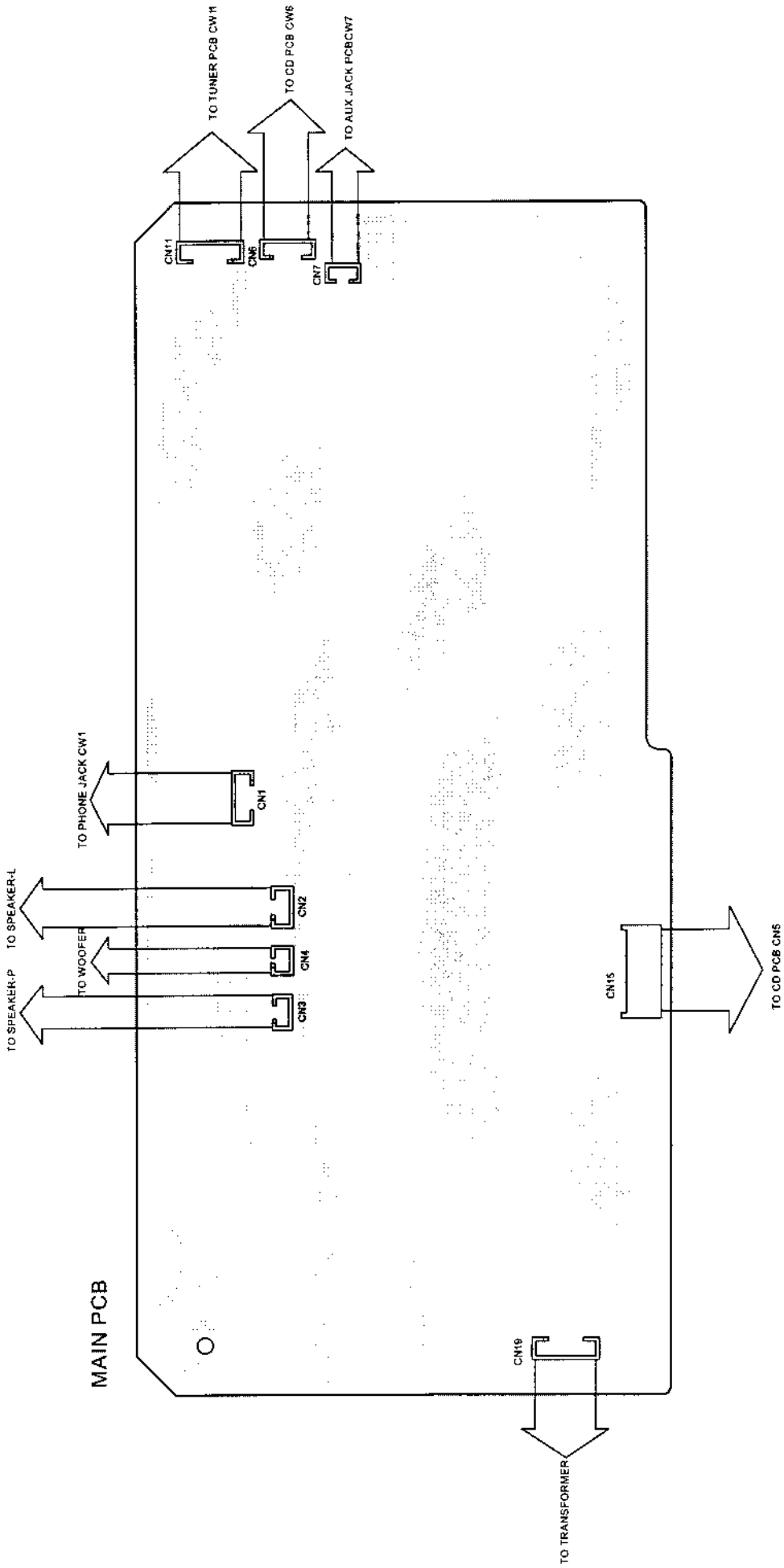

# SL-D90

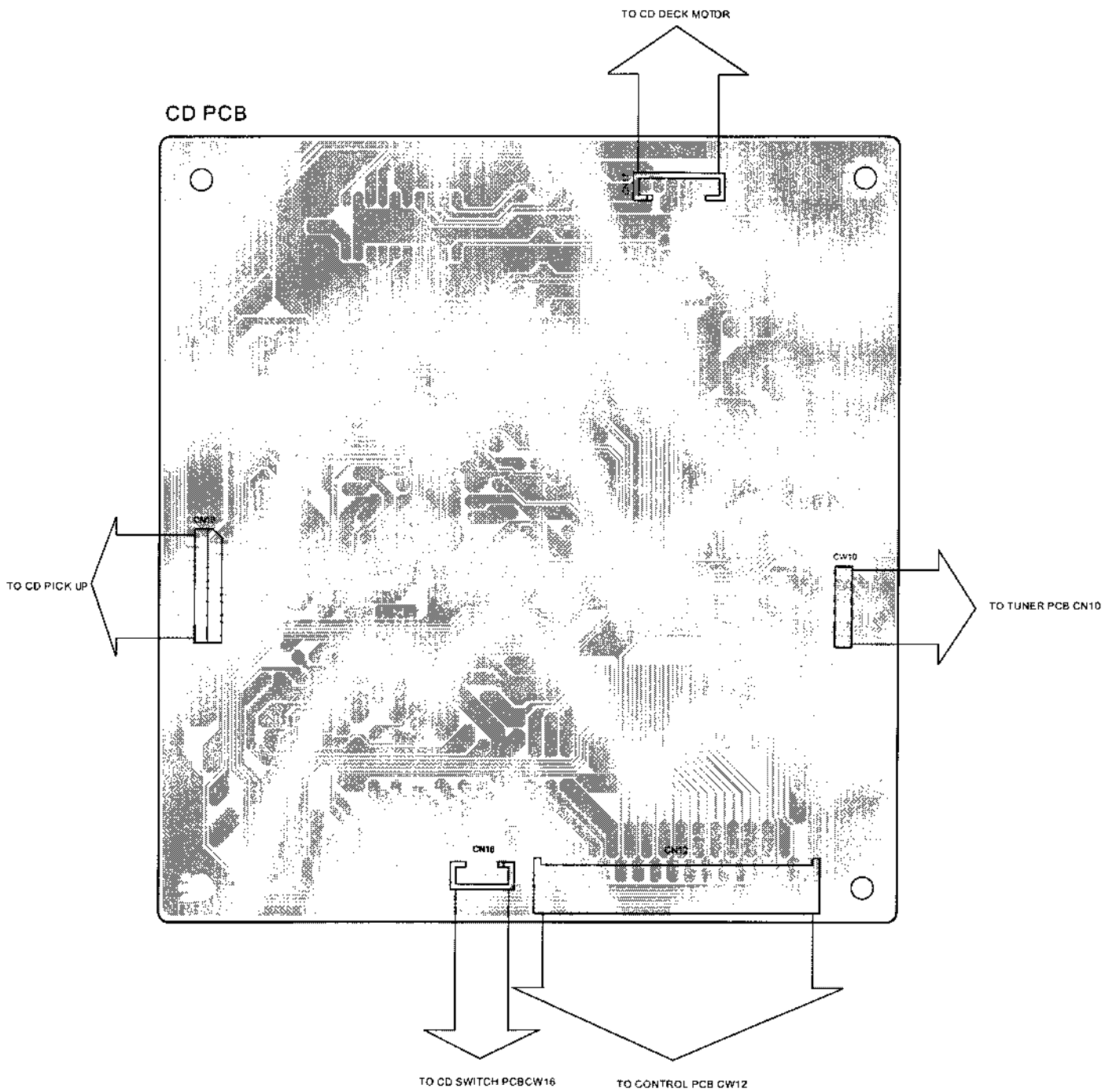



MAIN PCB

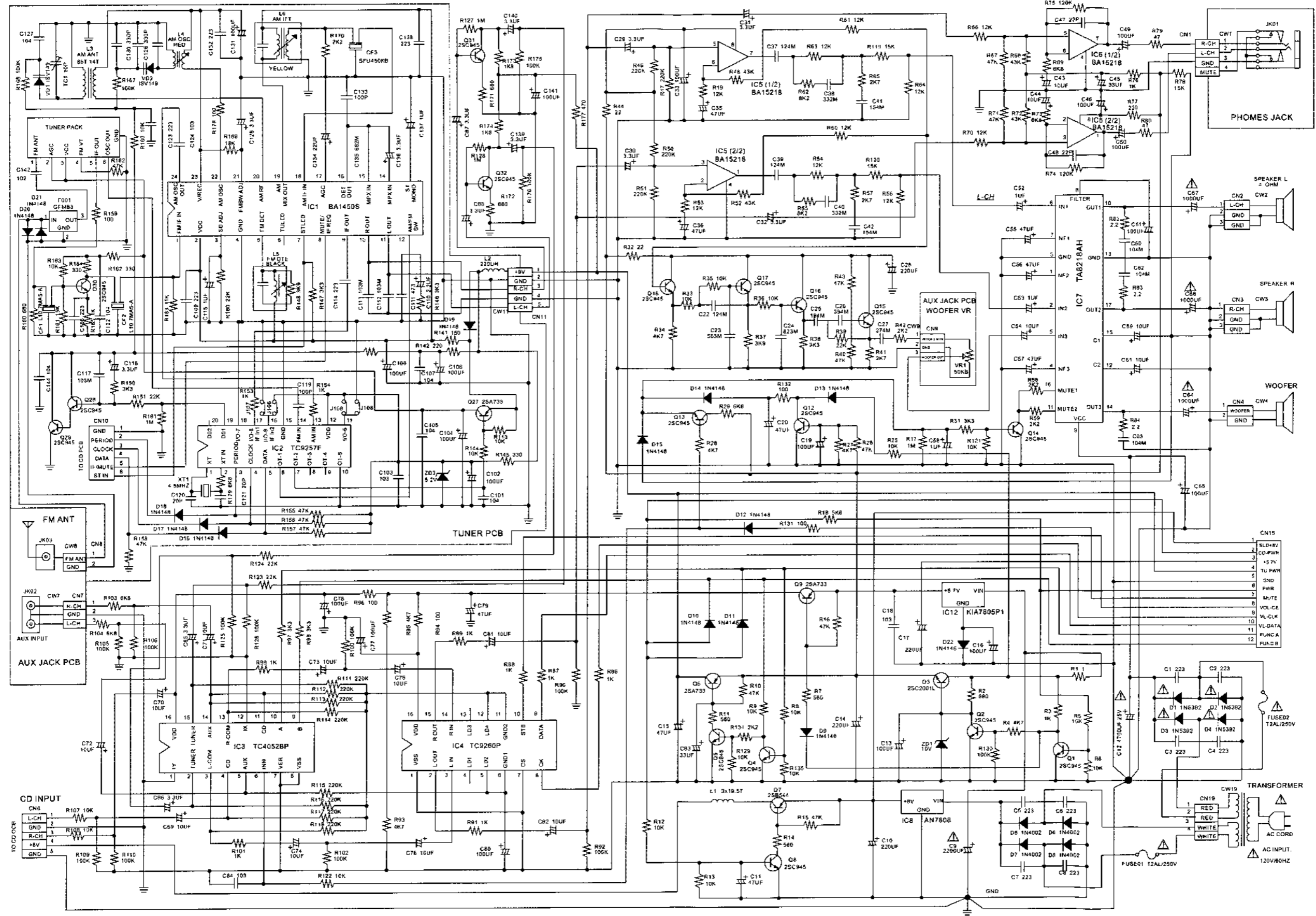

SL-D90

AM/FM STEREO DIGITAL RADIO WITH CD PLAYER

CD PCB

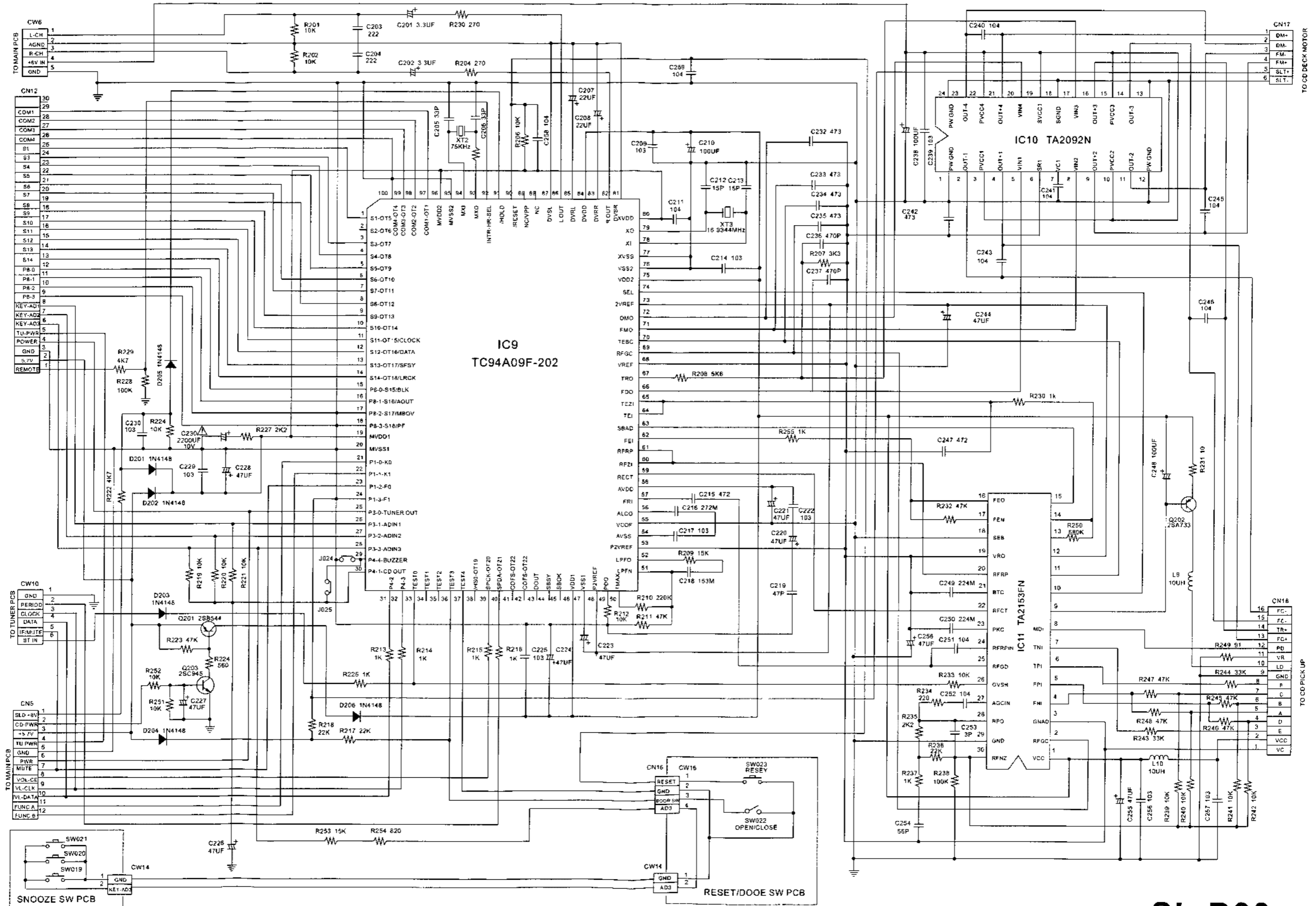

**SL-D90**  
**AM/FM STEREO DIGITAL RADIO**  
**WITH CD PLAYER**

# CD CONTROL PCB

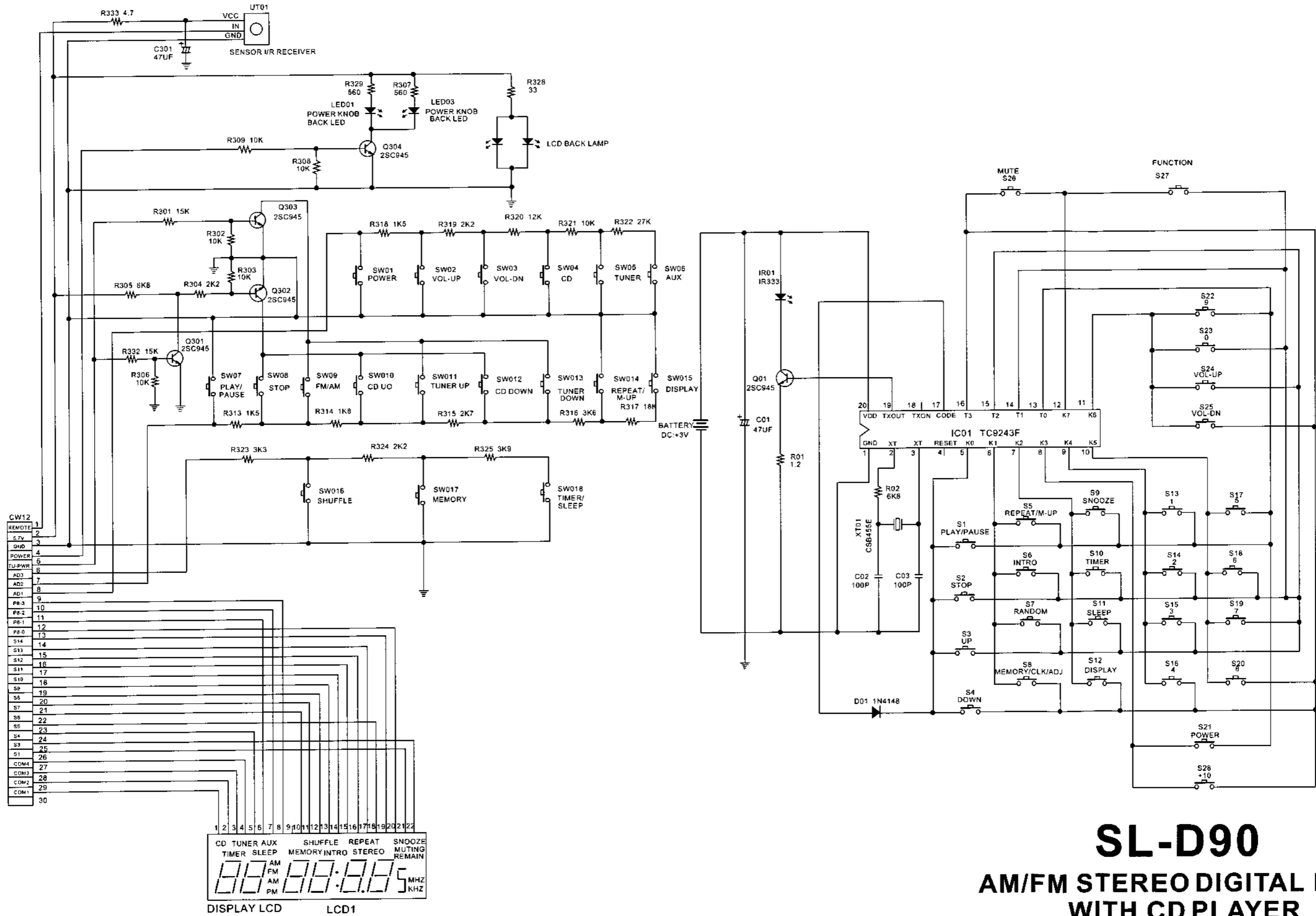

# SL-D90

## AM/FM STEREO DIGITAL RADIO WITH CD PLAYER