

**4-CH/STEREO RECEIVER**

**MODEL AS-970**

<b>SECTION 1</b>	<b>SERVICE MANUAL</b> .....	<b>3</b>
<b>SECTION 2</b>	<b>PARTS LIST</b> .....	<b>35</b>
<b>SECTION 3</b>	<b>SCHEMATIC DIAGRAM</b> .....	<b>63</b>

---

SECTION 1

**SERVICE MANUAL**

TABLE OF CONTENTS

I.	SPECIFICATIONS .....	4
II.	DISMANTLING OF UNIT .....	6
III.	ARRANGEMENT OF MAIN PARTS .....	7
IV.	NECESSARY MEASURING INSTRUMENTS .....	8
V.	CLASSIFICATION OF VARIOUS P.C. BOARDS AND INTERCHANGEABILITY .....	9
VI.	FM TUNER SECTION ADJUSTMENTS .....	10
	1. FM IF CIRCUIT ADJUSTMENT .....	10
	2. FRONT END FM IF MATCHING ADJUSTMENT .....	13
	3. TRACKING ADJUSTMENT .....	14
	4. SENSITIVITY ADJUSTMENT .....	14
	5. SIGNAL METER SENSITIVITY ADJUSTMENT .....	15
	6. STEREO SEPARATION ADJUSTMENT .....	15
	7. TUNING METER CENTER ADJUSTMENT .....	15
	8. MUTING LEVEL ADJUSTMENT (STEREO INDICATOR SENSITIVITY ADJUSTMENT) .....	15
VII.	AM TUNER SECTION ADJUSTMENTS .....	18
	1. AM IF CIRCUIT ADJUSTMENT .....	18
	2. TRACKING ADJUSTMENT .....	19
	3. SENSITIVITY ADJUSTMENT .....	20
VIII.	TUNING CORD THREADING .....	21
IX.	POWER AMPLIFIER ADJUSTMENTS .....	22
	1. CURRENT ADJUSTMENT AT NON-INPUT .....	22
	2. POWER TRANSISTOR VOLTAGE DISTRIBUTION ADJUSTMENT .....	22
X.	COMPOSITE VIEWS OF COMPONENTS .....	27

# I. SPECIFICATIONS

An asterisk next to a figure indicates the minimum guaranteed performance.

## § AMPLIFIER SECTION

RATED OUTPUT	4-CHANNEL	26W at 8Ω (1 channel operation 1 kHz 0.5%)
	2-CHANNEL POWER DOUBLER	50W at 8Ω (1 channel operation 1 kHz 0.5%)
FREQUENCY RESPONSE	PHONO	100 Hz 13±1.5 dB 10 kHz -13.5±1.5 dB
	AUX	20 Hz/-2.0 dB, 50 kHz/-3.0 dB
POWER BAND WIDTH		10 Hz to 50 kHz
INPUT SENSITIVITY	PHONO	3 mV (-48±1.5 dB)
	MIC	3 mV (-48±1.5 dB)
	AUX	170 mV (-13±1.5 dB)
	TAPE 1, 2	180 mV (-12.5±1.5 dB)
	TAPE 3	150 mV (-14±1.5 dB)
	CD-4	150 mV (-14±1.5 dB)
SIGNAL TO NOISE RATIO	PHONO	Better than 35 dB
	MIC	Better than 35 dB
	AUX-DISC 4 CH	Better than 40 dB
	AUX-SQ	Better than 35 dB
	TAPE 1, 2	Better than 40 dB
	TAPE 3	Better than 45 dB
	CD-4	Better than 45 dB
RESIDUAL NOISE		Less than 4.3 mV (Less than -45 dB)
TONE CONTROL	BASS	10±1.5 dB at 100 Hz -10±1.5 dB at 100 Hz
	TREBLE	10±1.5 dB at 10 kHz -10±1.5 dB at 10 kHz
LOUDNESS CONTROL		8±2 dB at 100 Hz 4.5±2 dB at 10 kHz
FILTER	HIGH CUT	-7±1.5 dB at 10 kHz
	LOW CUT	-6±1.5 dB at 50 Hz
CROSS TALK		Better than 50 dB
LEFT-RIGHT DEVIATION		Within 3 dB
FRONT-REAR DEVIATION		Within 3 dB
RECORDING OUTPUT	TAPE 1 DIN	32 mV (-27.5±1.5 dB)
	PIN	170 mV (-13±1.5 dB)
	TAPE 2	170 mV (-13±1.5 dB)
	TAPE 3	150 mV (-14.5±1.5 dB)
DISTORTION FACTOR		Less than 0.1% (8Ω 10W output)

## § SQ SECTION

	Input		F.L	F.R	R.L	R.R
	CROSS TALK	F.L	1 kHz	0±2 dB	-15±2 dB	-2.5±2 dB
F.R		1 kHz	-15±2 dB	0±2 dB	-2.5±2 dB	-2.5±2 dB
PHASE DEVIATION	F.L	1 kHz	0°		-115±20°	
	F.R	1 kHz		0°		+65±20°

## § FM SECTION

	Input		F.L	F.R	R.L	R.R
	CROSS TALK	F.L	1 kHz	0±2 dB	-12±2 dB	-1±2 dB
F.R		1 kHz	-12±2 dB	0±2 dB	-6±2 dB	-1±2 dB
PHASE DEVIATION	F.L	1 kHz	0°		+90±20°	
	F.R	1 kHz		0°		-90±20°

## § FM TUNER SECTION

FREQUENCY RANGE	J 75 to 91±1 MHz U 87 to 109±1 MHz
DIAL TRACKING ERROR	±250 kHz
SENSITIVITY (IHF)	1.9 µV *Less than 3.5 µV (Less than 11 dB)
SENSITIVITY DEVIATION	Within 3 dB
IMAGE REJECTION RATIO	80 dB *Better than 70 dB
IF REJECTION RATIO	100 dB *Better than 80 dB
SPURIOUS REJECTION RATIO	Better than 80 dB
CAPTURE RATIO (IHF)	Less than 2 dB
SELECTIVITY	70 dB *Better than 60 dB
AM SUPPRESSION RATIO	Better than 45 dB
SIGNAL TO NOISE RATIO	MONAURAL 70 dB *Better than 50 dB STEREO Better than 50 dB
DISTORTION FACTOR	MONAURAL 0.4% *Less than 0.5% STEREO 0.7% *Less than 1.5%
FREQUENCY RESPONSE	J -11±1.5 dB at 10 kHz U -14±1.5 dB at 10 kHz
STEREO SENSITIVITY	14 µV (23±3 dB)
STEREO INDICATOR SENSITIVITY	14 µV (23±3 dB)
STEREO SEPARATION	40 dB *Better than 35 dB
REJECTION RATIO	Better than 50 dB
L-R REVIATION	Within 3 dB
RECORDING OUTPUT	PIN 170 mV (-13±1.5 dB) DIN 35 mV (-27.5±1.5 dB)

## § AM TUNER SECTION

FREQUENCY RANGE	525±5 kHz to 1,650±20 kHz
DIAL TRACKING ERROR	Within 2%
SENSITIVITY (IHF)	200 µV *Less than 350 µV (Less than 50 dB)
SENSITIVITY DEVIATION	Within 6 dB
IMAGE REJECTION RATIO	60 dB *Better than 50 dB
IF REJECTION RATIO	50 dB *Better than 45 dB
SELECTIVITY	Better than 30 dB
SIGNAL TO NOISE RATIO	Better than 40 dB
DISTORTION FACTOR	Less than 1.5%
FREQUENCY RESPONSE	-15 dB at 3 kHz

## § OTHER

TRANSISTORS	2SA706-3 (1) (2) ... 5 2SA733 (P) (Q) (R) ... 1 2SC313 (E) (F) ... 1 2SC711 (E) (F) ... 7 2SC839 (H) ... 3 2SC922 (L) ... 2	2SC945 (P) (Q) (R) ... 2 2SC1096 (K) (L) ... 1 2SC1124 (1) (2) ... 8 2SC1312 (F) (G) ... 40 2SC1444 (O) (Y) ... 8
FET	2SK30 ... 1	
I.C.	LA1221 ... 4	LA3300 ... 1
DIODES	1N34A ... 7 1N60 ... 7 10D1 ... 12	WG599 ... 1 HIF1 400V 3A ... 8
ZENER DIODES	WZ-130 ... 2	
VARIATORS	STV-3H ... 4	
POWER SOURCE	100 to 240V A.C. 50/60 Hz 120V A.C. 60 Hz (CSA Models)	
POWER CONSUMPTION	350W/4Ω (at maximum output) 190W/4Ω (at 1/3 output)	
DIMENSIONS	587(W)x168(H)x397(D) mm (23.1"x6.6"x15.6")	
WEIGHT	17.4 kg (38.3 lbs)	

NOTE: Specifications subject to change without notice.

## II. DISMANTLING OF UNIT

In case of trouble, etc. necessitating disassembly, please disassemble in the order shown in photographs. Re-assemble in reverse order.

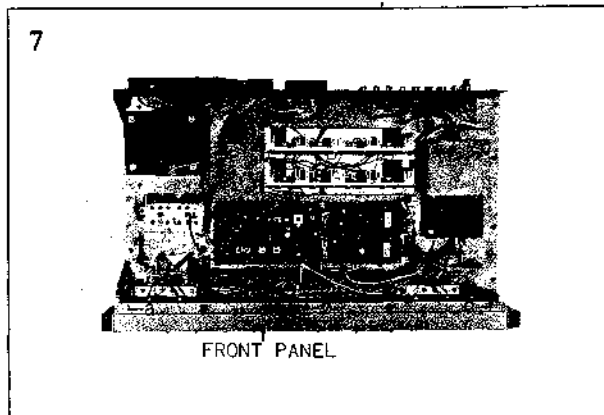
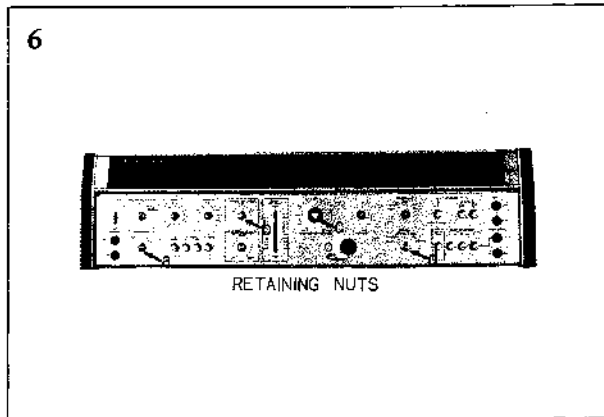
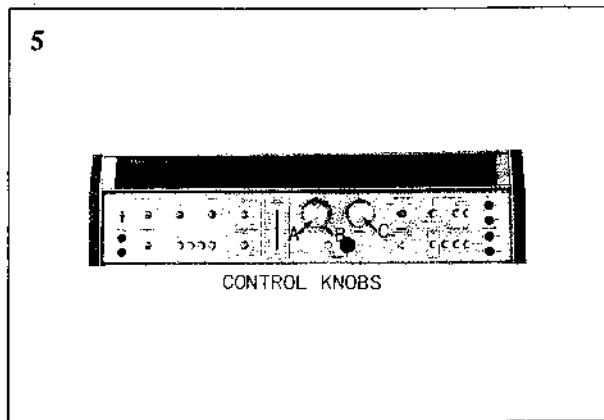
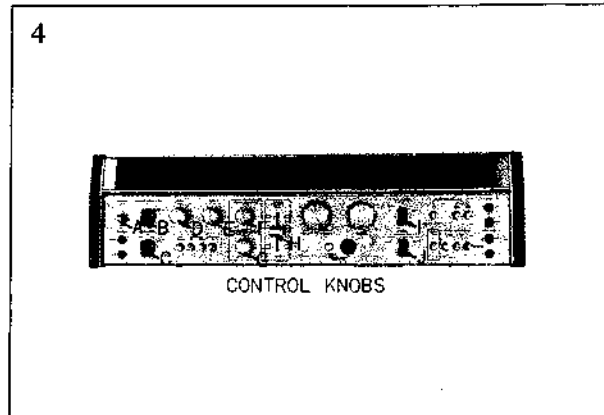
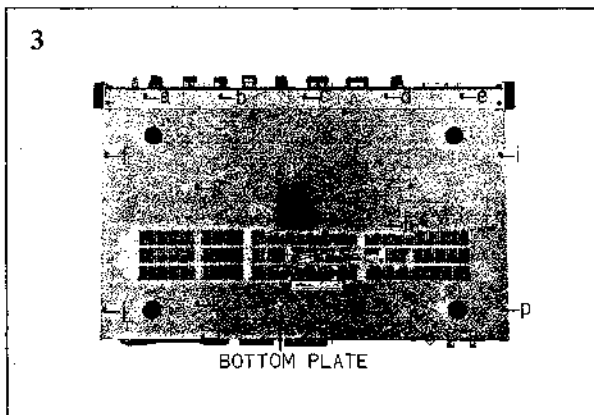
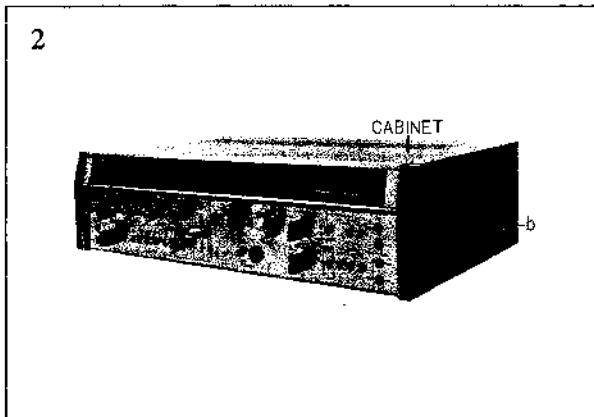
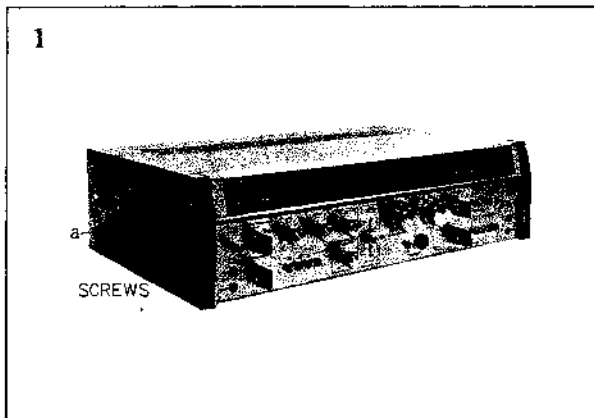

### III. ARRANDEMENT OF MAIN PARTS

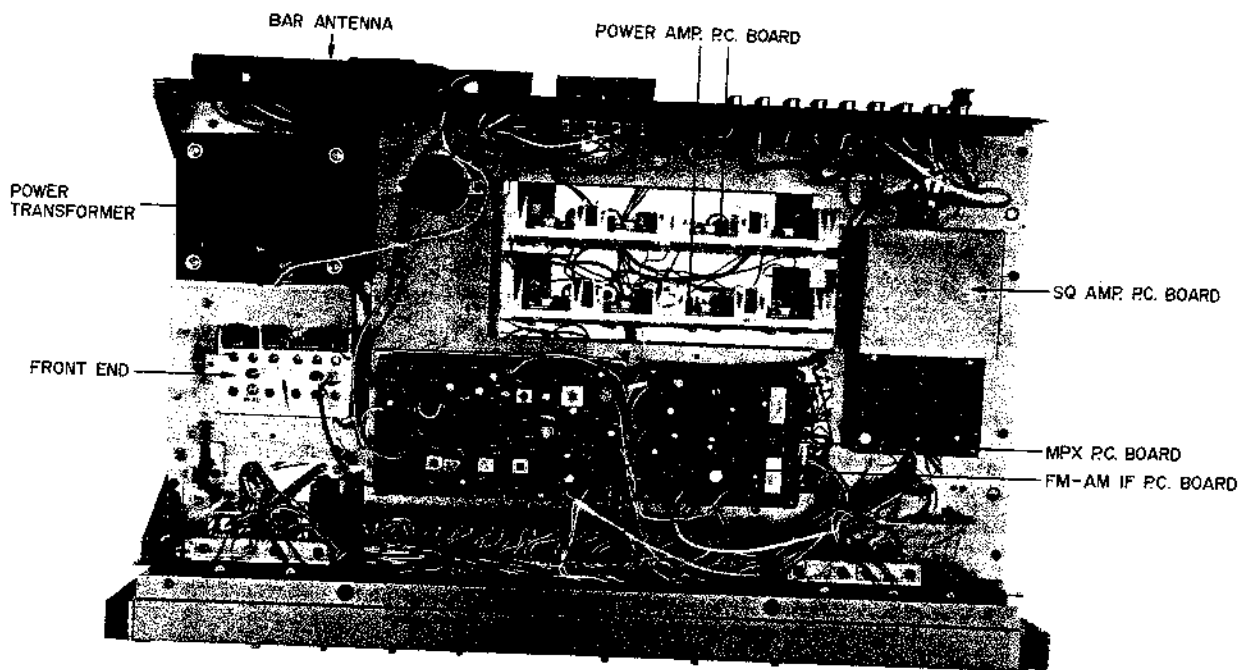

Fig. 1

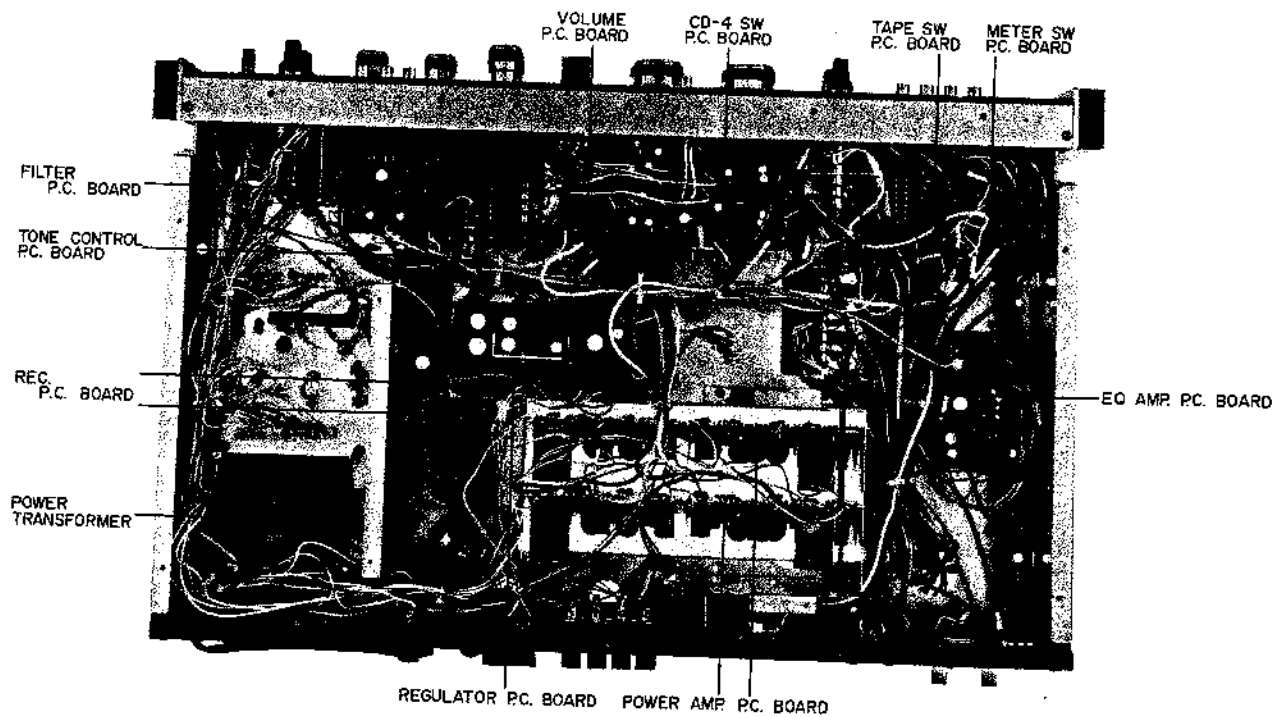

Fig. 2

#### IV. NECESSARY MEASURING INSTRUMENTS

---

Measuring Instrument	Model	For
AM-FM Radio IF Genescope	Meguro MSW-721C	FM and AM IF Adjustment
FM Standard Signal Generator	Meguro MSG-278G	FM Tracking, Sensitivity Adjustment
FM Stereo Modulator	Meguro MSG-211E	Stereo Separation Adjustment
AM Standard Signal Generator	Meguro MSG-221C	AM Tracking, Sensitivity Adjustment
AM Loop Antenna	Meguro MLA-1001B	AM Tracking, Sensitivity Adjustment
High Sensitivity V.T.V.M.	Kikusui 183E	Sensitivity, Stereo Separation Adjustment
Distortion Meter	Shibasoku 760C	Sensitivity Adjustment
Ampere Meter	Yokogawa 2011	Power Amp. Adjustment

Chart 1

## V. CLASSIFICATION OF VARIOUS P.C. BOARDS AND INTERCHANGEABILITY

P.C. Board		Model				
		AS-980	AS-960	AA-940	AA-930	AA-920
METER SWITCH P.C. BOARD	97-5001	98-5003				
BALANCE CONTROL P.C. BOARD	97-5002					
CD-4 SWITCH P.C. BOARD	97-5003	98-5004	96-5003			
TAPE SWITCH P.C. BOARD	97-5004	98-5002	96-5001			
FILTER P.C. BOARD	97-5005					
MIC, DUB. P.C. BOARD	97-5006					
DIAL ILLUMINATION P.C. BOARD	97-5008	98-5001	97-5008	AA-5029	AA-5029	AA-5029
POWER AMP. P.C. BOARD	97-5009	92-5005	96-5008	94-5013	94-5013	92-5005
SQ. AMP. P.C. BOARD	97-5010	98-5015	97-5010			
VOLUME P.C. BOARD	98-5006	98-5006				
TONE CONTROL P.C. BOARD	98-5007	98-5007	96-5006	94-5025	94-5025	92-5010
EQ. AMP. P.C. BOARD	98-5008	98-5008	96-5004	94-5012	94-5012	92-5003
RECT. P.C. BOARD	98-5010	98-5010	98-5010			
LAMP RECT. P.C. BOARD	98-5011	98-5011				
HEADPHONE P.C. BOARD	98-5012	98-5012	98-5012	94-5022	94-5022	94-5022
REGULATOR P.C. BOARD	98-5084	98-5084*	98-5084*			
MPX. P.C. BOARD	94-5008	94-5008*	91-5033	94-5008	94-5008	94-5008
FM-AM IF P.C. BOARD	94-5009	94-5009*	91-5033	94-5009	94-5009	94-5009

NOTE: \* . . . No Interchangeable

Chart 2



# VI. FM TUNER SECTION ADJUSTMENTS

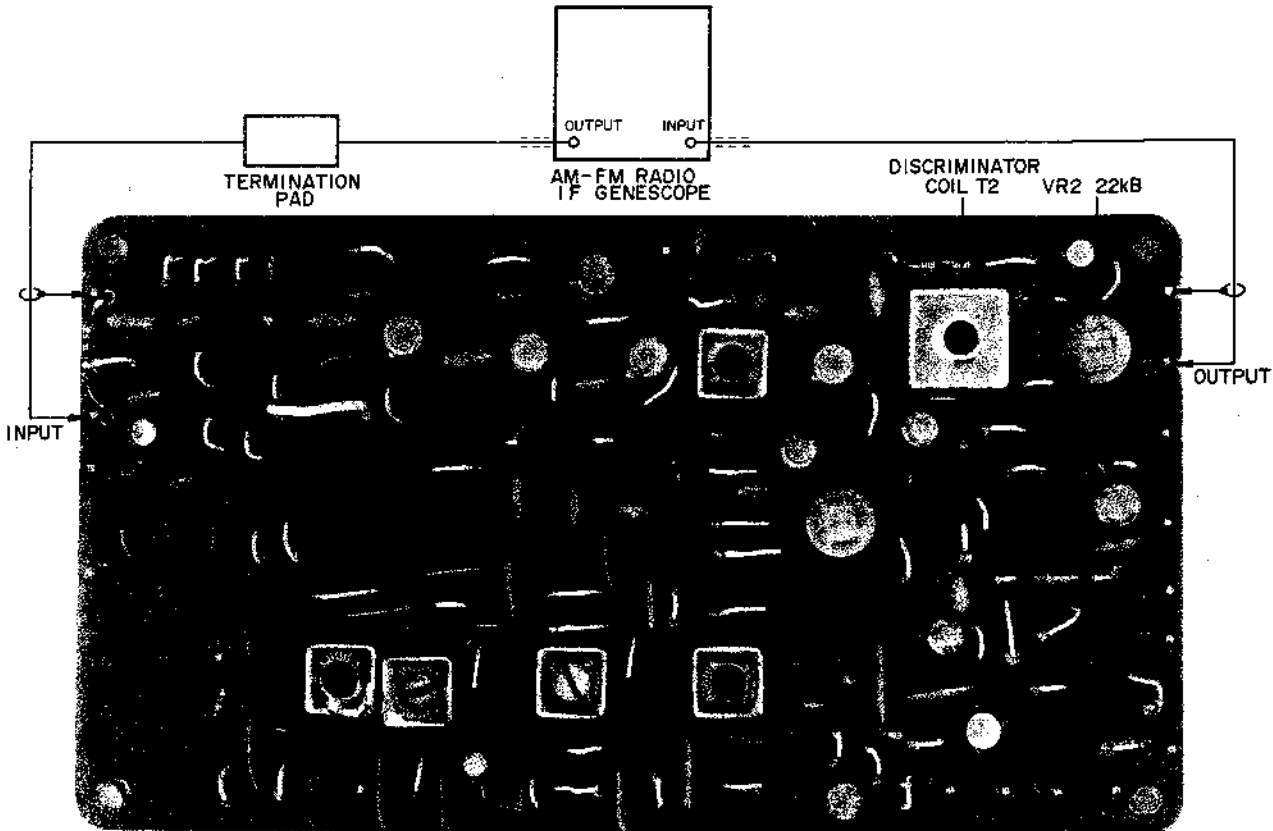

Fig. 3 INSTRUMENT CONNECTIONS

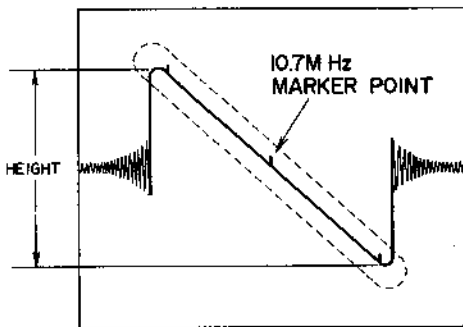

Fig. 4

Vertical Gain	0.3Vp-p to 1 cm
GENESCO Output Level	50 dB
Discriminator Coil	T2
S Curve Height	5 cm

Chart 3

## 1. FM IF CIRCUIT ADJUSTMENT

- 1) Connect the lead wires from an AM-FM Radio IF GENESCOPE (hereinafter referred to as GENESCOPE) to the input as well as the output of the FM-AM IF P.C. Board as shown in Fig. 3.
- 2) Set GENESCOPE to FM mode and adjust vertical gain (refer to Chart 3).
- 3) Set Receiver SELECTOR to FM AUTO, and tuning indicator needle to extreme right end of the dial. At this time confirm that a noise element does not enter the S Curve shown in Fig. 4.
- 4) Adjust output level of GENESCOPE (refer to Chart 3).
- 5) Manually center FM-AM IF P.C. Board semi-fixed resistor VR2 22 kΩ.
- 6) Adjust the upper and lower cores of Discriminator Coil so that the wave height value of the S Curve shown in Fig. 4 is maximum and the linearity of the part indicated by the dotted line is optimum. (Refer to Fig. 4 and Chart 3)

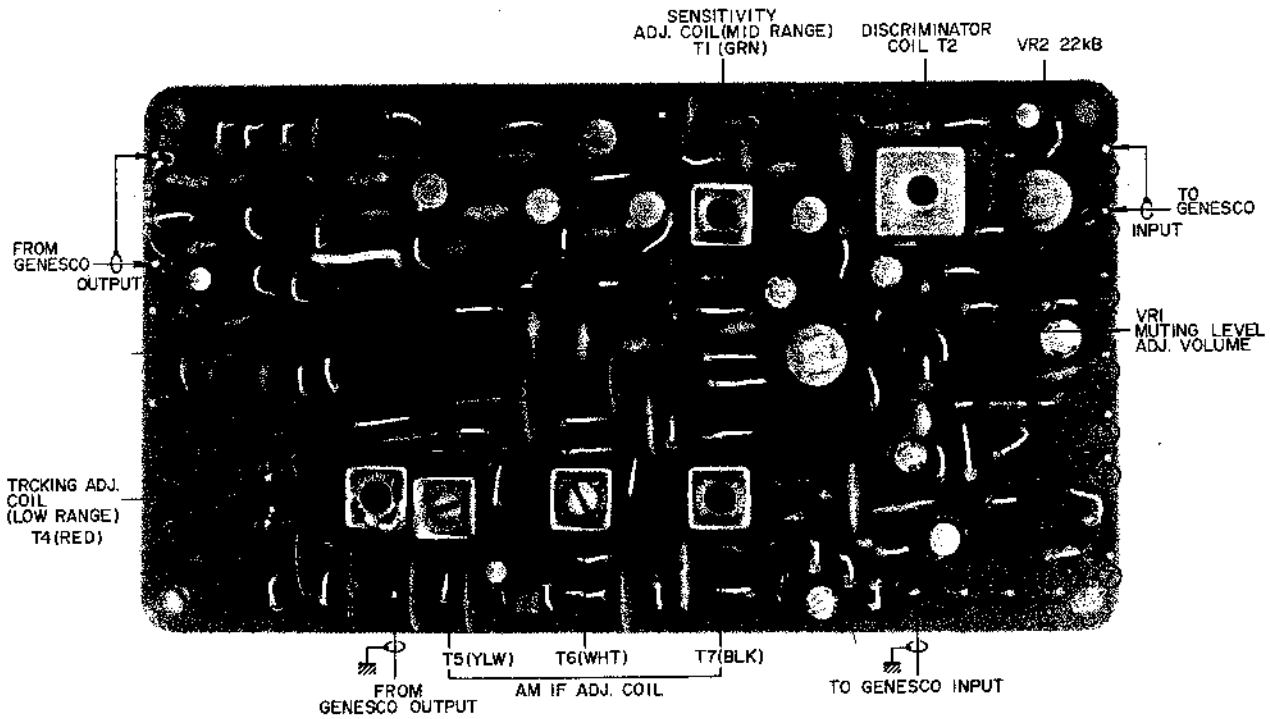

Fig. 5 FM-AM IF P.C. BOARD 94-5009

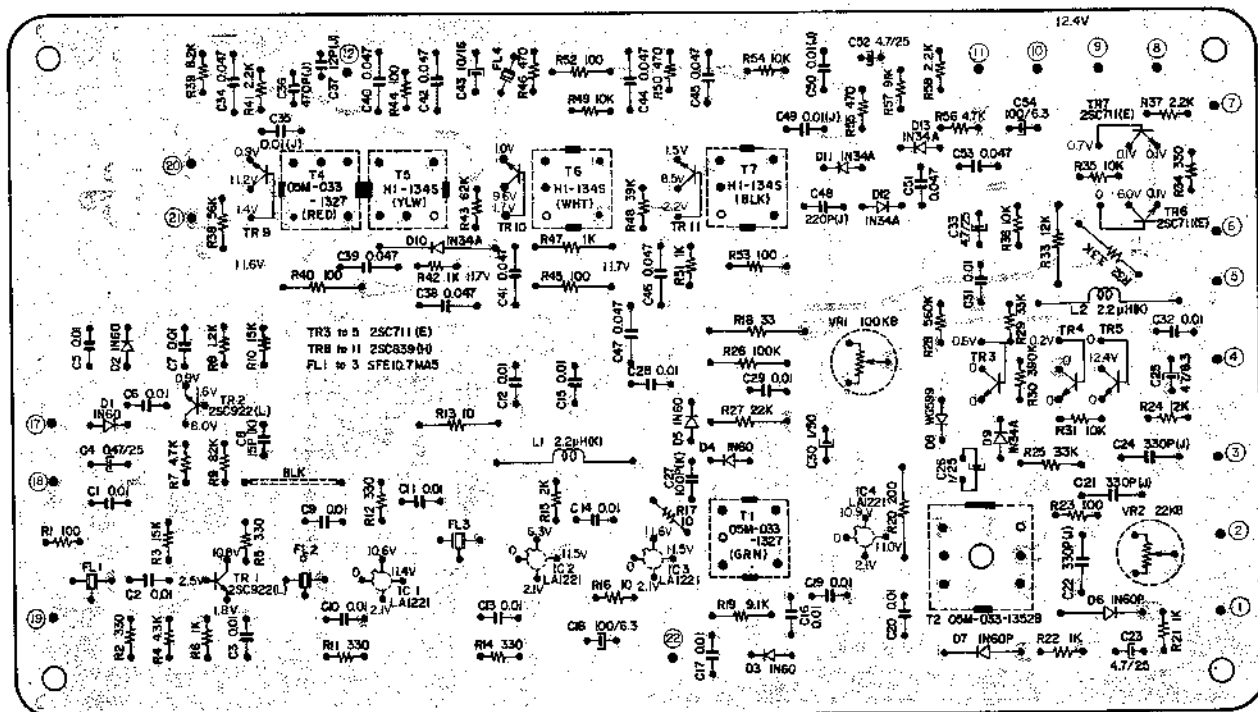
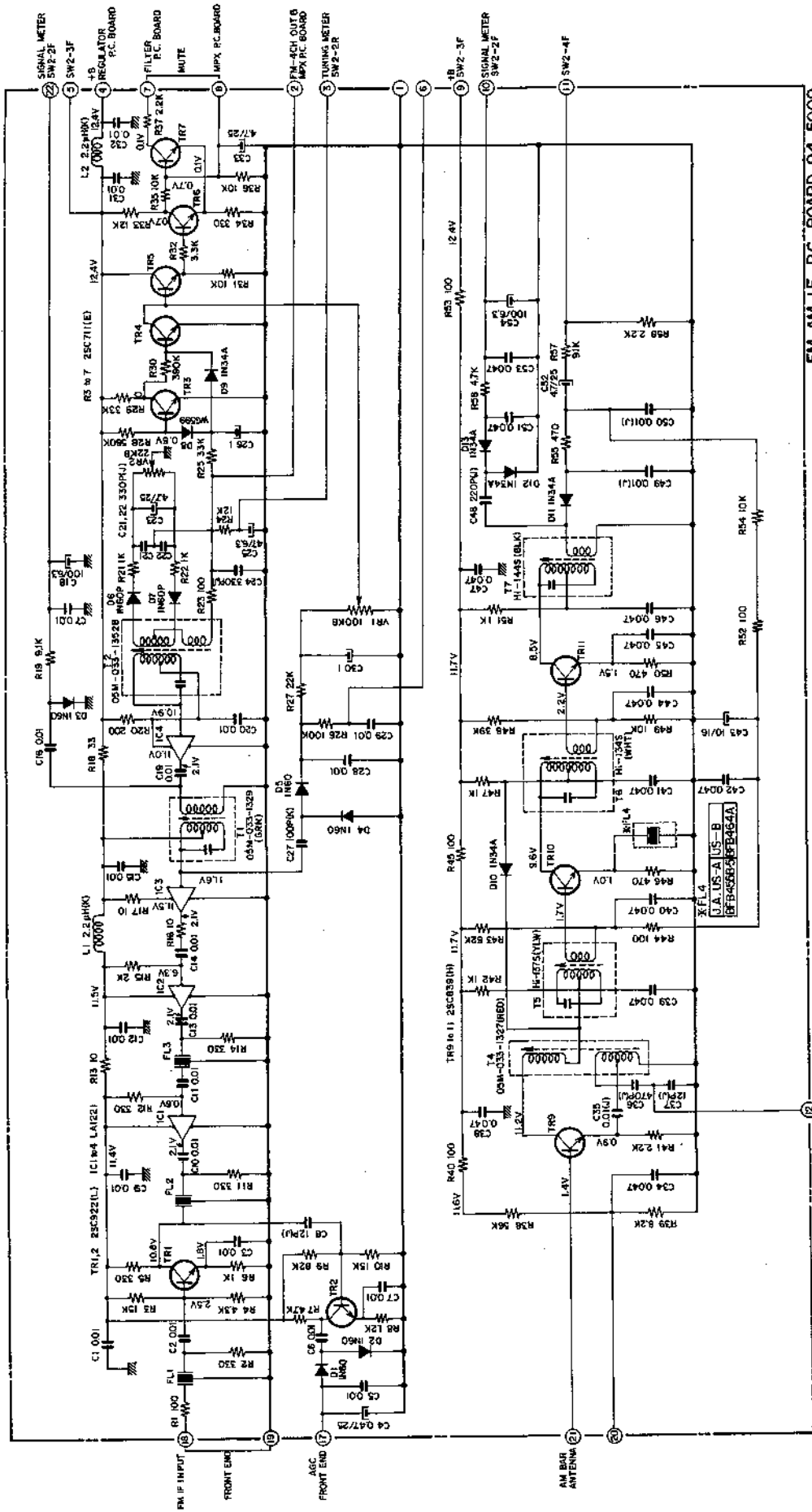

Fig. 6 FM-AM IF P.C. BOARD 94-5009 (Rev.)



FM-AM IF P.C. BOARD 94-5009

NOTE  
 UNLESS OTHERWISE SPECIFIED  
 ALL RESISTORS IN  $\Omega$  /  $\text{K}$  /  $\text{M}$  /  $\Omega$   
 ALL CAPACITORS IN  $\text{PF}$  /  $\text{N}$  /  $\text{Z}$

Schematic 1

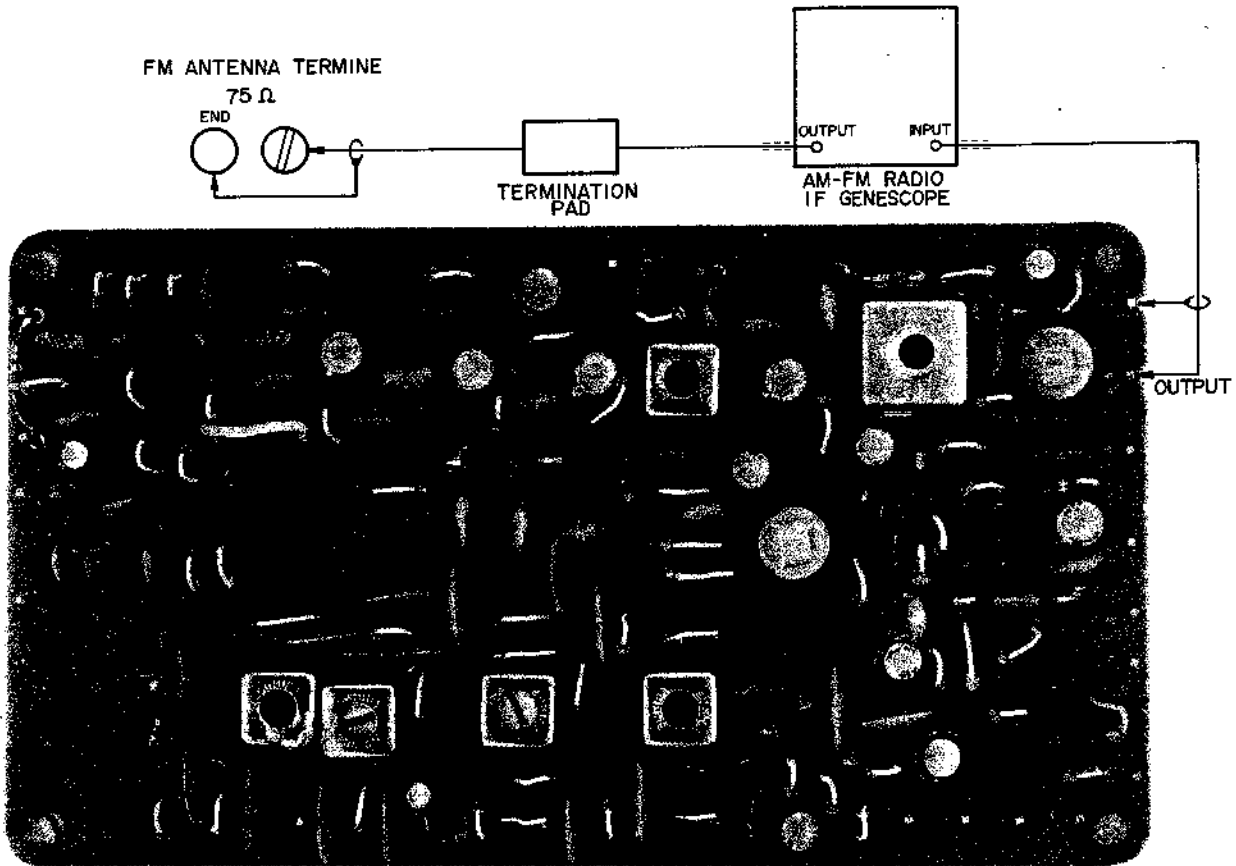

Fig. 7 INSTRUMENT CONNECTIONS

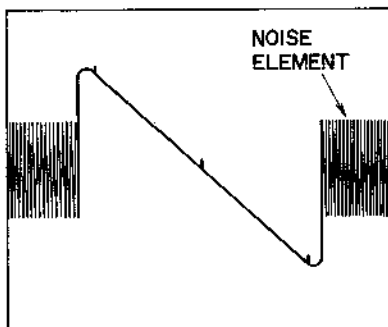

Fig. 8

## 2. FRONT END AND FM IF MATCHING ADJUSTMENT

- 1) Connect the GENESCOPE lead wires to the 75 $\Omega$  FM ANTENNA TERMINALS of the Receiver as well as to the FM IF P.C. Board output as shown in Fig. 7.
- 2) Set the GENESCOPE to FM mode and adjust the vertical gain of GENESCOPE to obtain a 10 mm amplitude of the 0.3Vp-p calibration voltage on GENESCOPE Screen and set the GENESCOPE attenuator to 100 dB.
- 3) Set Receiver SELECTOR to FM AUTO, and tuning indicator needle to extreme right end of the dial.
- 4) Adjust the upper core of Front End IF Coil (Fig. 18) to obtain maximum wave height value of S Curve in Fig. 8, and adjust the lower core to obtain maximum noise level.
- 5) Make this adjustment again following FM Sensitivity Adjustment.

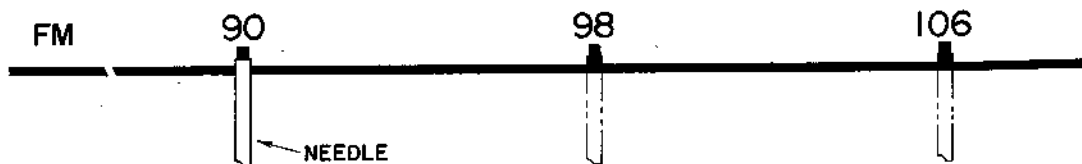

Fig. 9 INSTRUMENT CONNECTIONS

Ref. In making Tracking Adjustment, set dial to following positions.

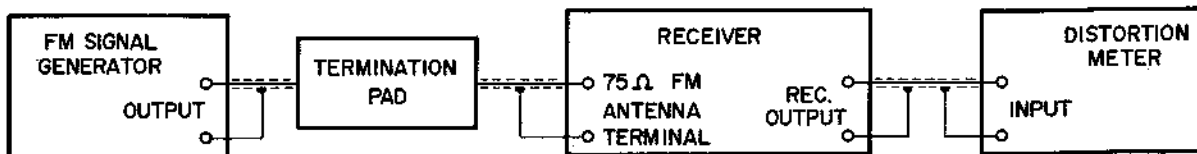

Fig. 10

FM S.G. Output	40 dB
Core (Low Range)	Lo
Trimmer Condenser (High Range)	TCo

Chart 4

Core (Low Range)	LR, LR, LA
Trimmer Condenser (High Range)	TCR, TCR, TCA
IF Coil (Mid Range)	IF
Discriminator Coil (Mid Range)	T2

Chart 5

### 3. TRACKING ADJUSTMENT

- 1) Connect the various measuring instruments as shown in Fig. 9.
- 2) Set the oscillation frequency of the FM SIGNAL GENERATOR (hereinafter referred to FM S.G.) to 90 MHz (400 Hz 100% internal modulation), and set the output of the FM S.G. to 46 dB. (Refer to Chart 4)
- 3) Set Receiver SELECTOR to FM AUTO, and tuning indicator needle to 90 MHz. (Refer to Fig. 10)
- 4) Adjust Core Lo of Front End (Fig. 18) until the distortion meter level is maximum and the distortion factor is minimum. (Refer to Chart 4)
- 5) Set the oscillation frequency of FM S.G. and tuning indicator needle to 106 MHz. (Refer to Fig. 10)
- 6) Adjust Trimmer Condenser TCo of Front End (Fig. 18) until the distortion meter level is maximum and the distortion factor is minimum. (Refer to Chart 4)

### 4. SENSITIVITY ADJUSTMENT

- 1) Carry out these adjustments after the previously described Tracking Adjustments have been completed.
- 2) Measuring instrument connections are the same as described in Tracking Adjustments.
- 3) Set the oscillation frequency of the FM S.G. to 90 MHz (400 Hz, 100% internal modulation), set Receiver SELECTOR to FM AUTO, and set the tuning indicator needle to 90 MHz. (Refer to Fig. 10)
- 4) Adjust the FM S.G. Attenuator to obtain a 3% distortion factor.
- 5) Adjust the cores of Front End (Fig. 18) until the distortion meter level is maximum and the distortion factor is minimum. (Refer to Chart 5)
- 6) Set the oscillation frequency of FM S.G. and tuning indicator needle to 106 MHz. (Refer to Fig. 10)
- 7) Adjust the FM S.G. Attenuator to obtain a 3% distortion factor.
- 8) Adjust Trimmer Condensers of Front End (Fig. 18) until the distortion meter level is maximum and the distortion factor is minimum. (Refer to Chart 5)
- 9) Set the oscillation frequency of FM S.G. and the tuning indicator needle to 98 MHz. (Refer to Fig. 10)
- 10) Adjust the FM S.G. Attenuator to obtain a 3% distortion factor.
- 11) Adjust the upper and lower cores of IF Coil in Front End (Fig. 18) and the lower core of FM-AM IF P.C. Board Discriminator Coil until the distortion meter level is maximum and the distortion factor is minimum. (Refer to Chart 5)
- 12) Repeat adjustments outlined in Item 3) through 11) at 90 MHz, 98 MHz and 106 MHz two or three times for highest sensitivity.

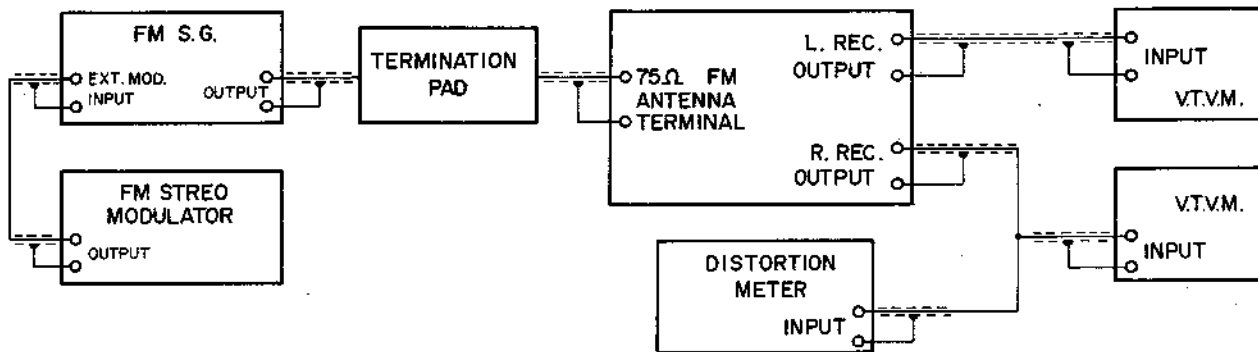

Fig. 11 INSTRUMENT CONNECTIONS

## 5. SIGNAL METER SENSITIVITY ADJUSTMENT

- 1) Supply a 98 MHz (400 Hz, 100% internal modulation) 60 dB signal to the Receiver from the FM S.G. Alignment is attained when the tuning meter indicator comes to the exact center of the meter.
- 2) Under the above conditions, adjust the core of Coil T1(GRN) of FM-AM IF P.C. Board to obtain maximum signal meter indication.

## 6. STEREO SEPARATION ADJUSTMENT

- 1) Connect the various measuring instruments as shown in Fig. 11.
- 2) Set the FM STEREO MODULATOR pilot signal 19 kHz to 10%, and the main signal 400 Hz (left channel + right channel) to 90% modulation, and supply this composite signal (ratio 9:1) to the FXT MOD. input terminal of the FM S.G.
- 3) Set the FM S.G. oscillation frequency to 98 MHz, and the Attenuator to 66 dB.
- 4) Set Receiver SELECTOR to FM AUTO, and the tuning indicator needle to 98 MHz to receive the FM S.G. Signal.
- 5) Set the output signal selector of FM STEREO MODULATOR to SUB.
- 6) Adjust the cores of MPX P.C. Board 19 kHz Filter L1(BLK) and 38 kHz Filter L2(WHT) until the distortion factor is minimum. (Refer to Fig. 12)
- 7) Set the output signal selector of FM STEREO MODULATOR to left channel.
- 8) Adjust the MPX Adjustment Volume located on rear panel of the Receiver until the right channel output level is minimum.

## 7. TUNING METER CENTER ADJUSTMENT

After completing the adjustments outlined in Parts 1 through 4 of this manual, set the FM S.G. Attenuator to non-output condition, and adjust the upper core of FM-AM IF P.C. Board Discriminator Coil T2 shown in Fig. 5 until the tuning indicator needle of tuning meter comes to the center.

Then set Receiver dial to 98 MHz, supply a 98 MHz (400 Hz, 100% internal modulation) 66 dB signal from the FM S.G., and fine adjust the lower core of Discriminator Coil T2 for minimum distortion factor.

## 8. MUTING LEVEL ADJUSTMENT (STEREO INDICATOR SENSITIVITY ADJUSTMENT)

- 1) Connect the various measuring instruments as shown in Fig. 11.
- 2) Set the FM S.G. oscillation frequency to 98 MHz (400 Hz 100% internal modulation) and Attenuator to non-output condition.
- 3) Set receiver dial to 98 MHz.
- 4) Adjust FM-AM IF P.C. Board semi-fixed resistor VR1 68 kΩ so that when the attenuation decreases and the Attenuator scale is at 23 dB, signal output is emitted at both channels.

STEREO SEPARATION ADJ.

L1 (BLK) L2 (WHT)  
19k Hz FL. 38k Hz FL.

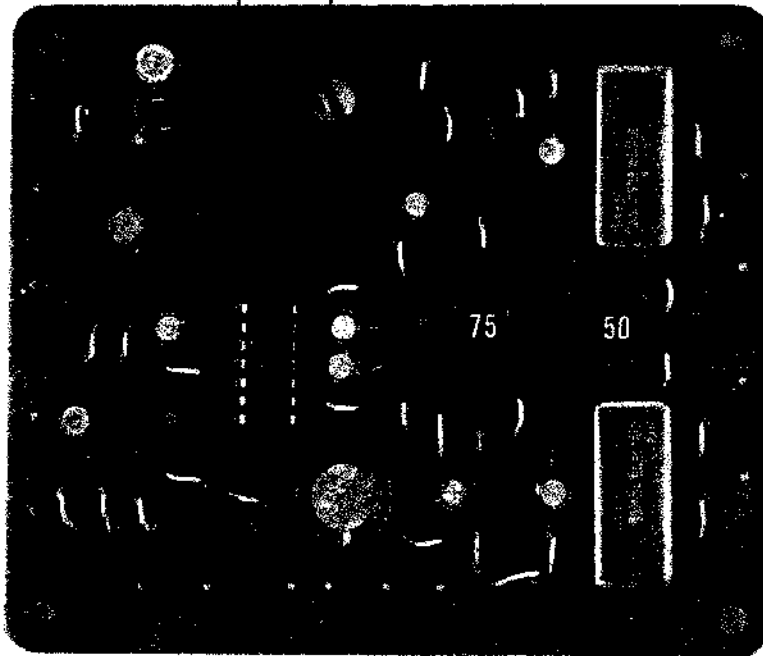

SW1  
DE EMPHASIS SW

Fig. 12 MPX P.C. BOARD 94-5008

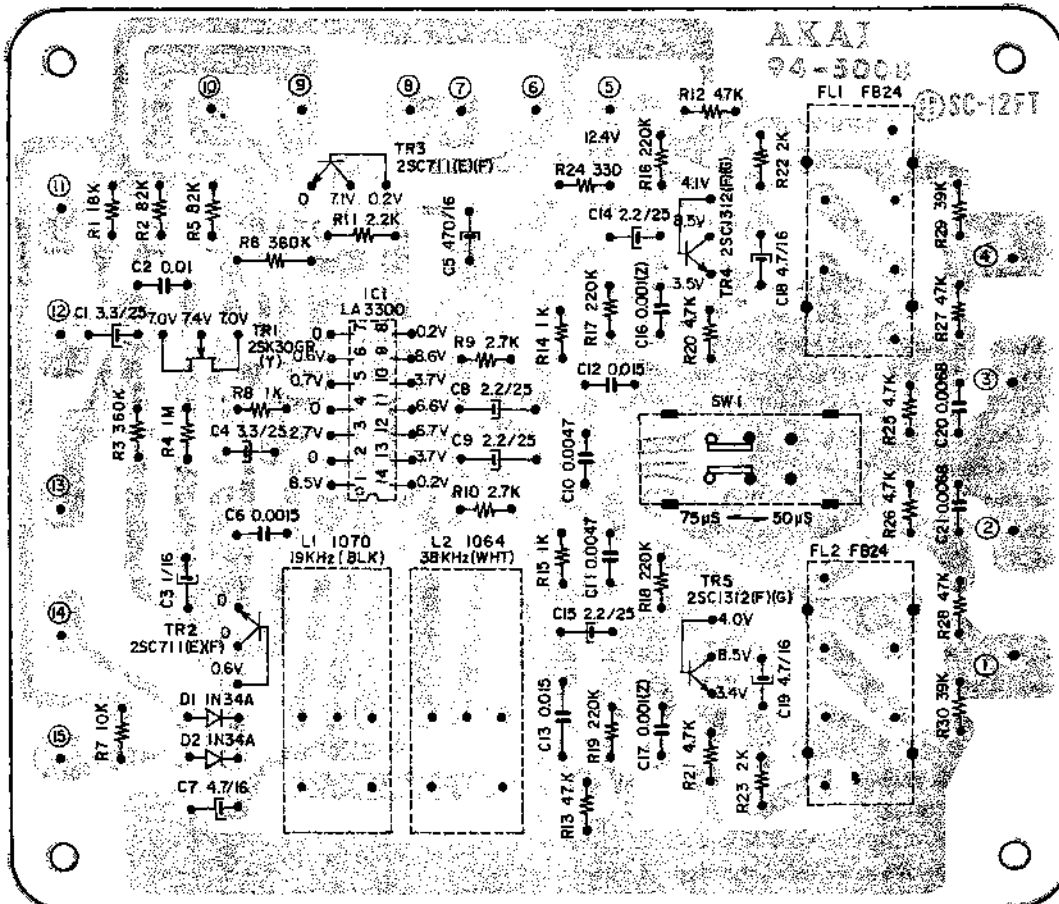
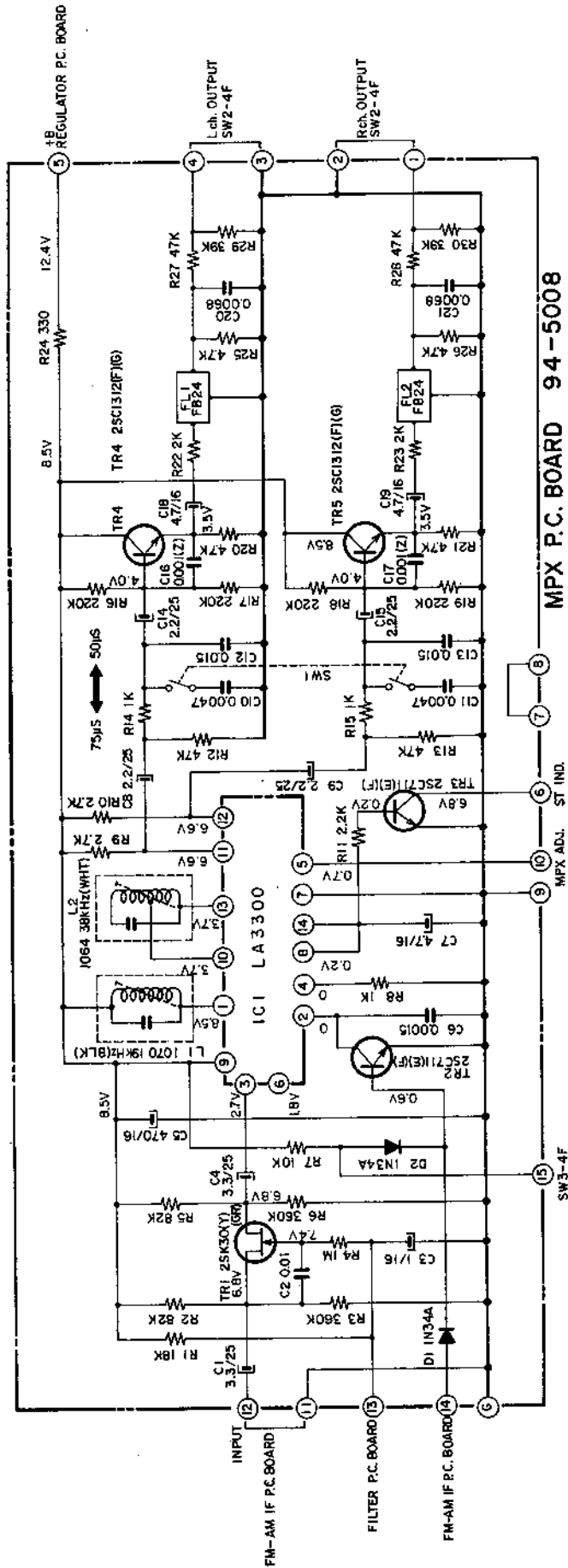

Fig. 13 MPX P.C. BOARD 94-5008 (Rev.)



MPX P.C. BOARD 94-5008

SCHEMATIC 2



# VII. AM TUNER SECTION ADJUSTMENTS

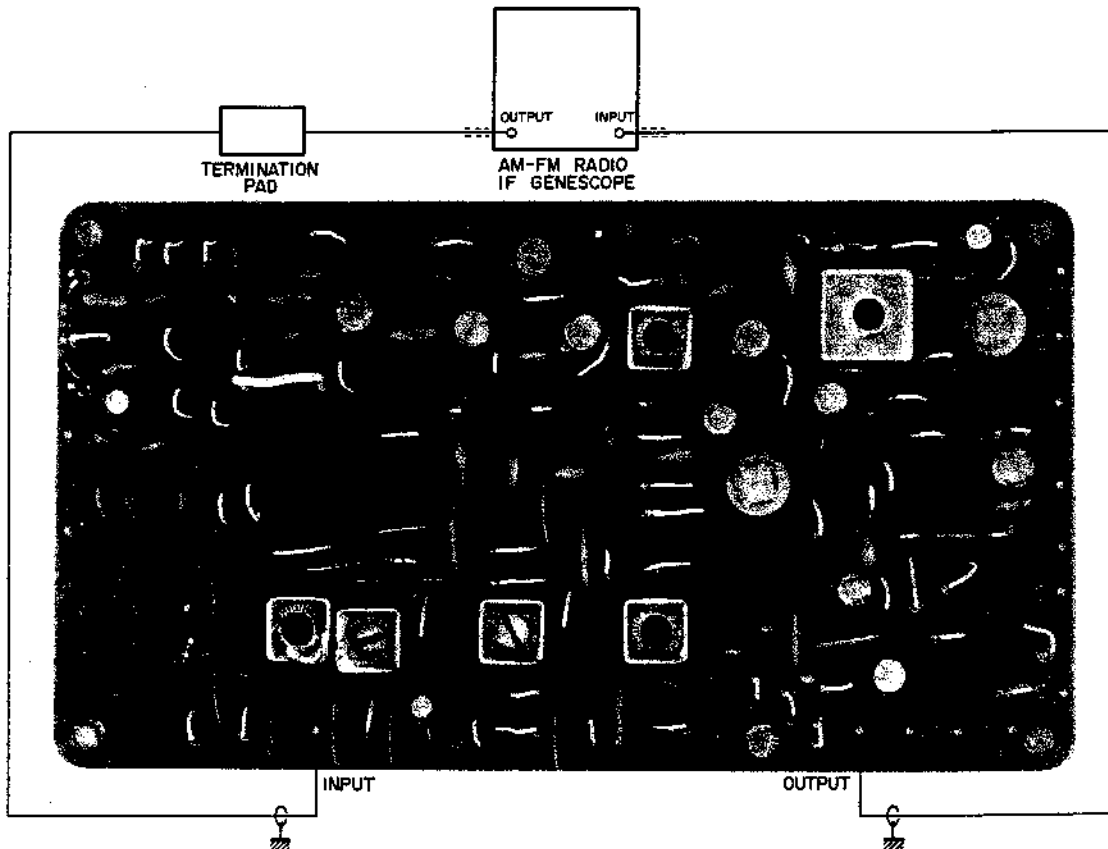

Fig. 14 INSTRUMENT CONNECTIONS

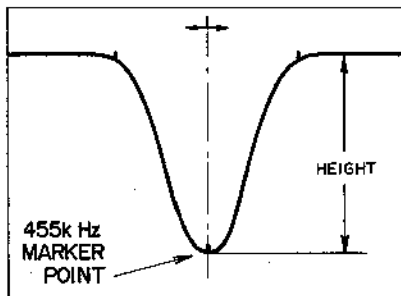

Fig. 15

Vertical Gain	0.3Vp-p to 1 cm
GENESCO Output Level	60 dB
Single Peaked Curve Height	4 cm

Chart 6

## 1. AM IF CIRCUIT ADJUSTMENT

- 1) Connect the AM-FM Radio IF GENESCOPE (hereinafter referred to as GENESCO) lead wires to input terminal as well as output terminal of the FM-AM IF P.C. Board as shown in Fig. 14.
- 2) Set GENESCO to AM mode and adjust vertical gain. (Refer to Chart 6)
- 3) Set Receiver SELECTOR to AM and set the tuning indicator needle to extreme right end of the dial.

NOTE: A noise element should not enter the single peaked curve shown in Fig. 15.

- 4) Adjust output level of GENESCO. (Refer to Chart 6)
- 5) Adjust the cores of FM-AM IF P.C. Board IFT T7(BLK) (refer to Fig. 14) so that the 455 kHz marker point of the single peaked curve displays maximum amplitude as shown in Fig. 15.
- 6) Adjust the cores of FM-AM IF P.C. Board IFT T6(WHT) and T5(YLW) (refer to Fig. 14) so that the left and right rise up characteristics of the single peaked curve shown in Fig. 15 are identical from the center (indicated by the dotted line in the figure).
- 7) In making this adjustment the single peaked curve marker point will differ according to the rank of the ceramic filter.

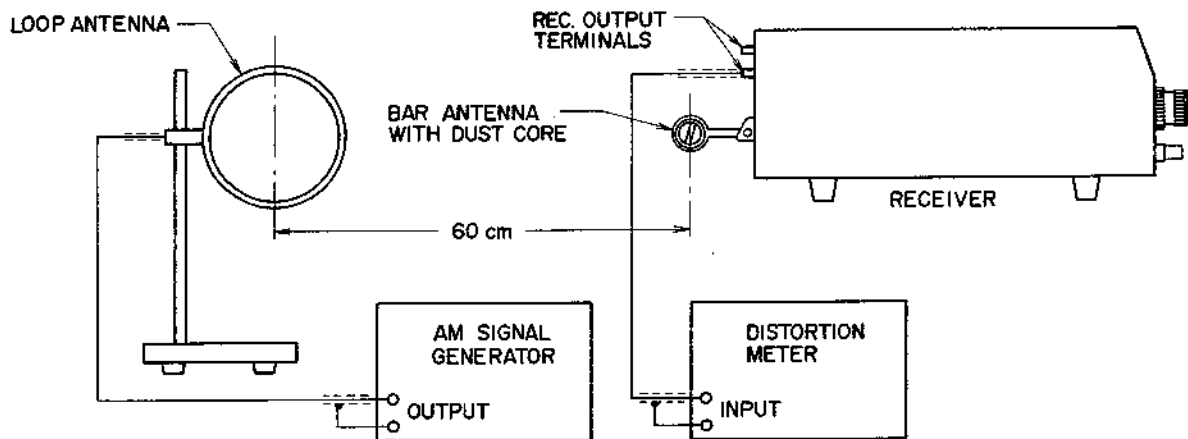

Fig. 16 INSTRUMENT CONNECTIONS

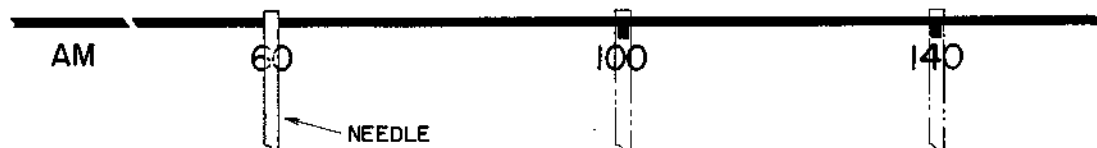

Fig. 17

Ref. In making Tracking Adjustments, set dial to following positions.

## 2. TRACKING ADJUSTMENT

- 1) Connect the various measuring instruments as shown in Fig. 16.
- 2) Set the oscillation frequency of the AM SIGNAL GENERATOR (hereinafter referred to as AM S.G.) to 600 kHz (400 Hz 30% internal modulation) and adjust the AM S.G. Attenuator, (Refer to Chart 7)
- 3) Set Receiver SELECTOR to AM and tuning indicator needle to 600 kHz. (Refer to Fig. 17)
- 4) Adjust the core of FM-AM IF P.C. Board Tracking Adjustment Coil T4(RED) in Fig. 5 until the distortion meter level is maximum and the distortion factor is minimum.
- 5) Set the oscillation frequency of AM S.G. and tuning indicator needle of Receiver to 1,400 kHz. (Refer to Fig. 17)
- 6) Adjust Front End Trimmer Condenser in Fig. 18 until the distortion meter level is maximum and the distortion factor is minimum. (Refer to Chart 7)
- 7) Repeat adjustments outlined in Item 2) through 6) two or three times for minimum tracking error.

AM S.G. Output	60 dB
Core (Low Range)	T4
Trimmer Condenser (High Range)	TC1

Chart 7

Bar Antenna Dust Core (Low Range)	Fig. 16
Trimmer Condenser (High Range)	TC1

Chart 8

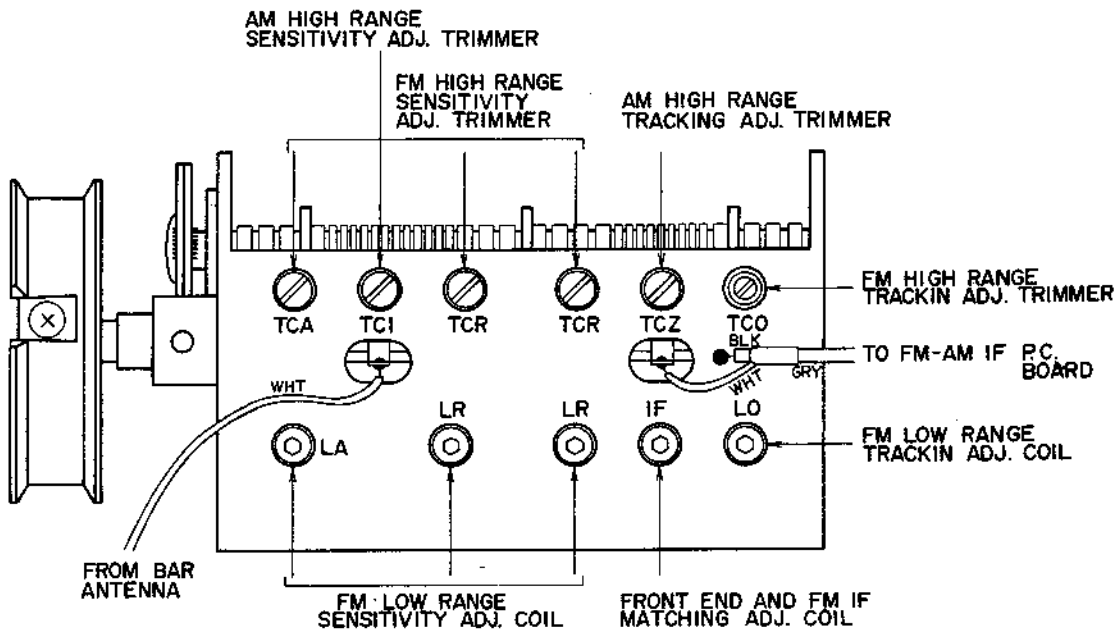

Fig. 18

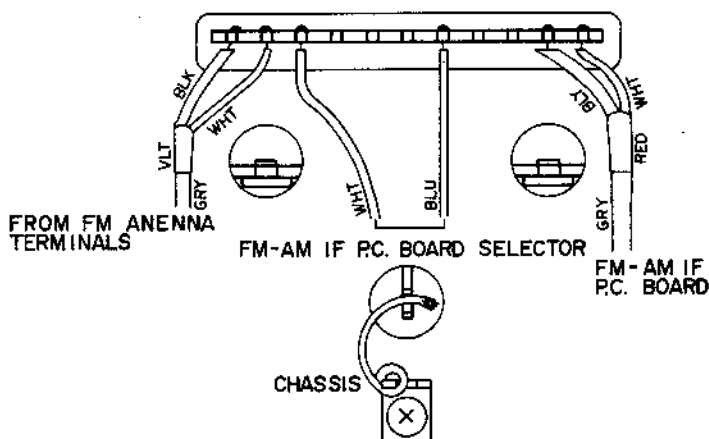

Fig. 19

### 3. SENSITIVITY ADJUSTMENT

- 1) Carry out these adjustments after the previously described Tracking Adjustments have been completed.
- 2) Measuring instrument connections are the same as described in Tracking Adjustments. (Refer to Fig. 16)
- 3) Set the oscillation frequency of the AM S.G. to 600 kHz (400 Hz 30% internal modulation). Set Receiver SELECTOR to AM and the tuning indicator needle to 600 kHz. (Refer to Fig. 17)
- 4) Adjust AM S.G. Attenuator to obtain a 10% distortion factor.
- 5) Adjust dust core of Bar Antenna shown in Fig. 16 until the distortion meter level is maximum and the distortion factor is minimum.
- 6) Set the oscillation frequency of AM S.G. and tuning indicator needle of Receiver to 1,400 kHz. (Refer to Fig. 17)
- 7) Adjust AM S.G. Attenuator to obtain a 10% distortion factor.
- 8) Adjust Front End trimmer condenser in Fig. 18 until the distortion meter level is maximum and the distortion factor is minimum. (Refer to Chart 8)
- 9) Repeat adjustment outlined in Items 3) through 8) at 600 kHz and 1,400 kHz two or three times for highest sensitivity.

# VIII. TUNING CORD THREADING

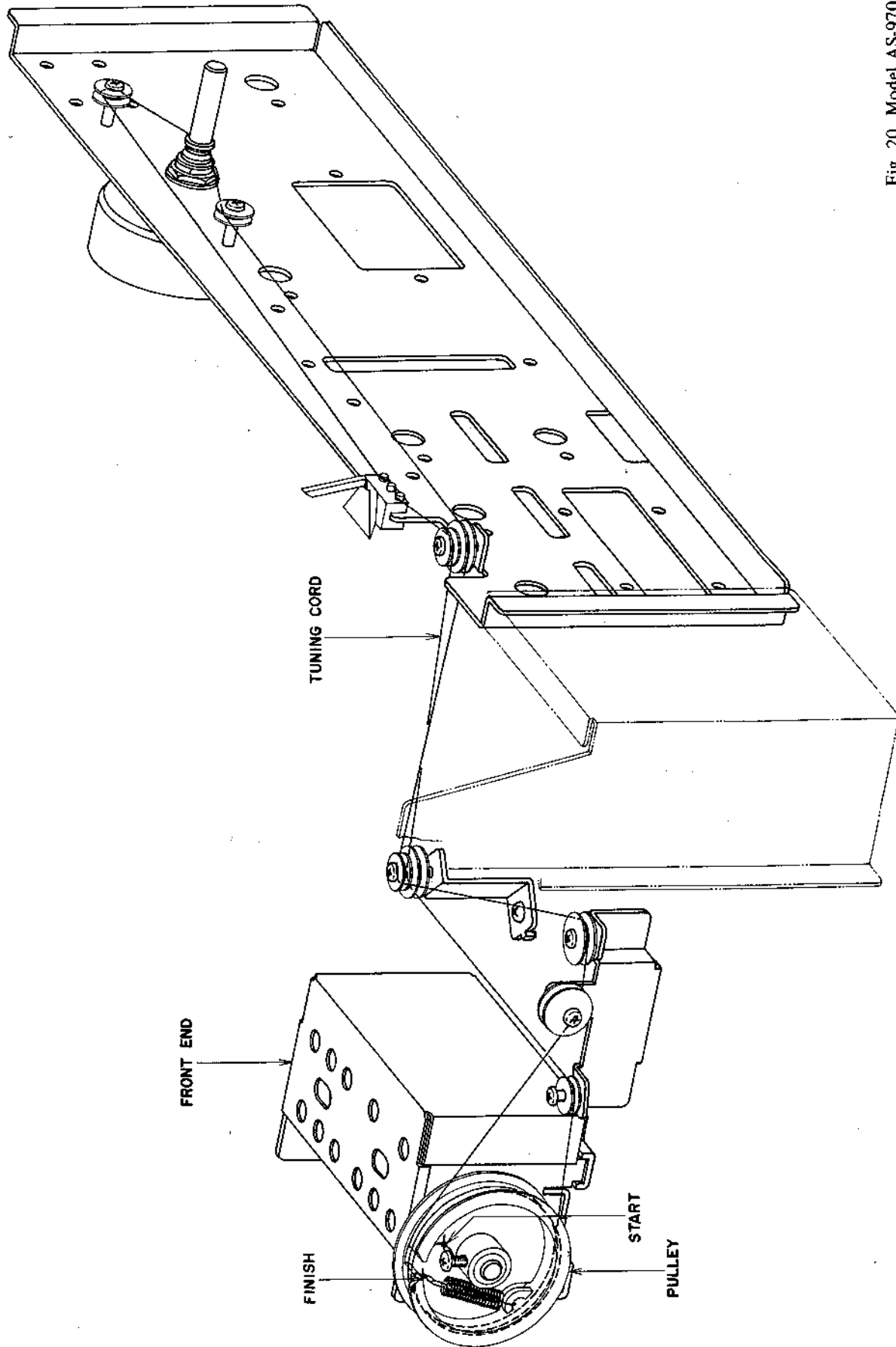
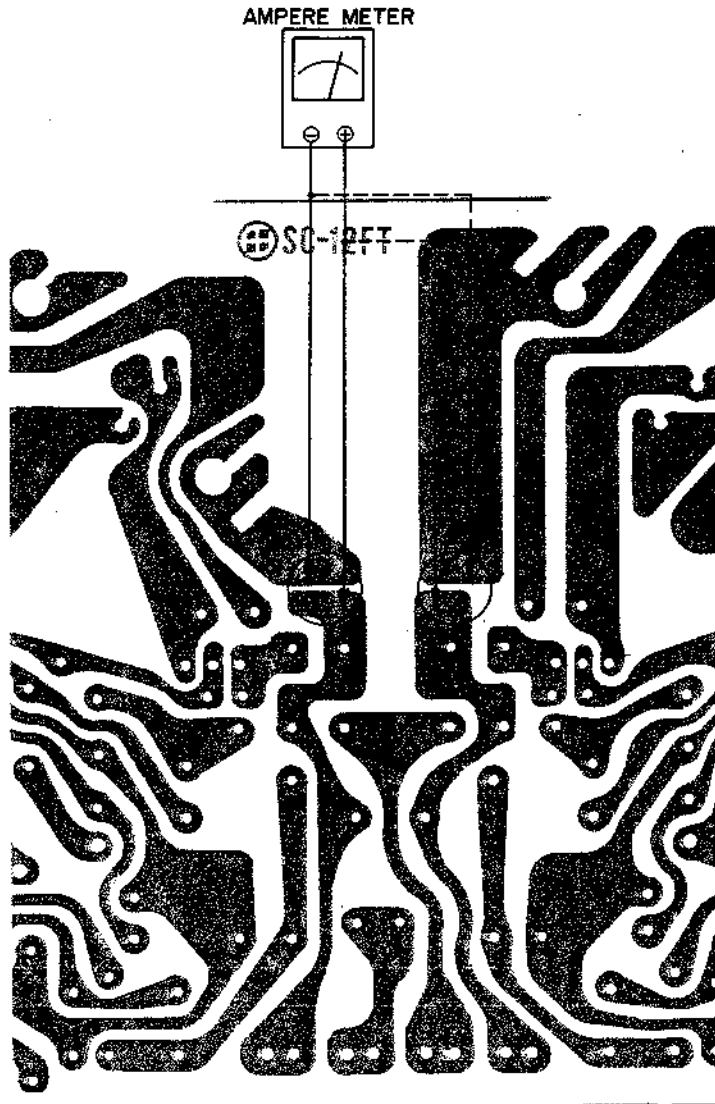

Fig. 20 Model AS-970

## IX. POWER AMPLIFIER ADJUSTMNTS



○ Indicates Soldering Points

Fig. 21

### 1. CURRENT ADJUSTMENT AT NON-INPUT

\* Turn Volume Control to minimum and proceed as follows:

- 1) Remove solder from soldering point of Power Amp. P.C. Board shown in Fig. 21.
- 2) Connect a 50 to 100 mA scale Ampere Meter as shown in Fig. 21. (Be sure to match Ampere Meter polarities).
- 3) Adjust Power Amp. P.C. Board semi-fixed resistor VR-2 100B shown in Fig. 22 to obtain an Ampere Meter indication of 40 mA.

### 2. VOLTAGE ADJUSTMENT BETWEEN POWER TRANSISTORS C-E

\* (Refer to Schematic Diagram)

- 1) Connect Voltage Meter to Power Amp. P.C. Board TR6 collector and terminal ⑧ shown in Fig. 22.
- 2) Adjust Power Amp. P.C. Board semi-fixed resistor VR1 30 kB shown in Fig. 22 so that the Voltage Meter indication is 1/2 of the supply voltage value.

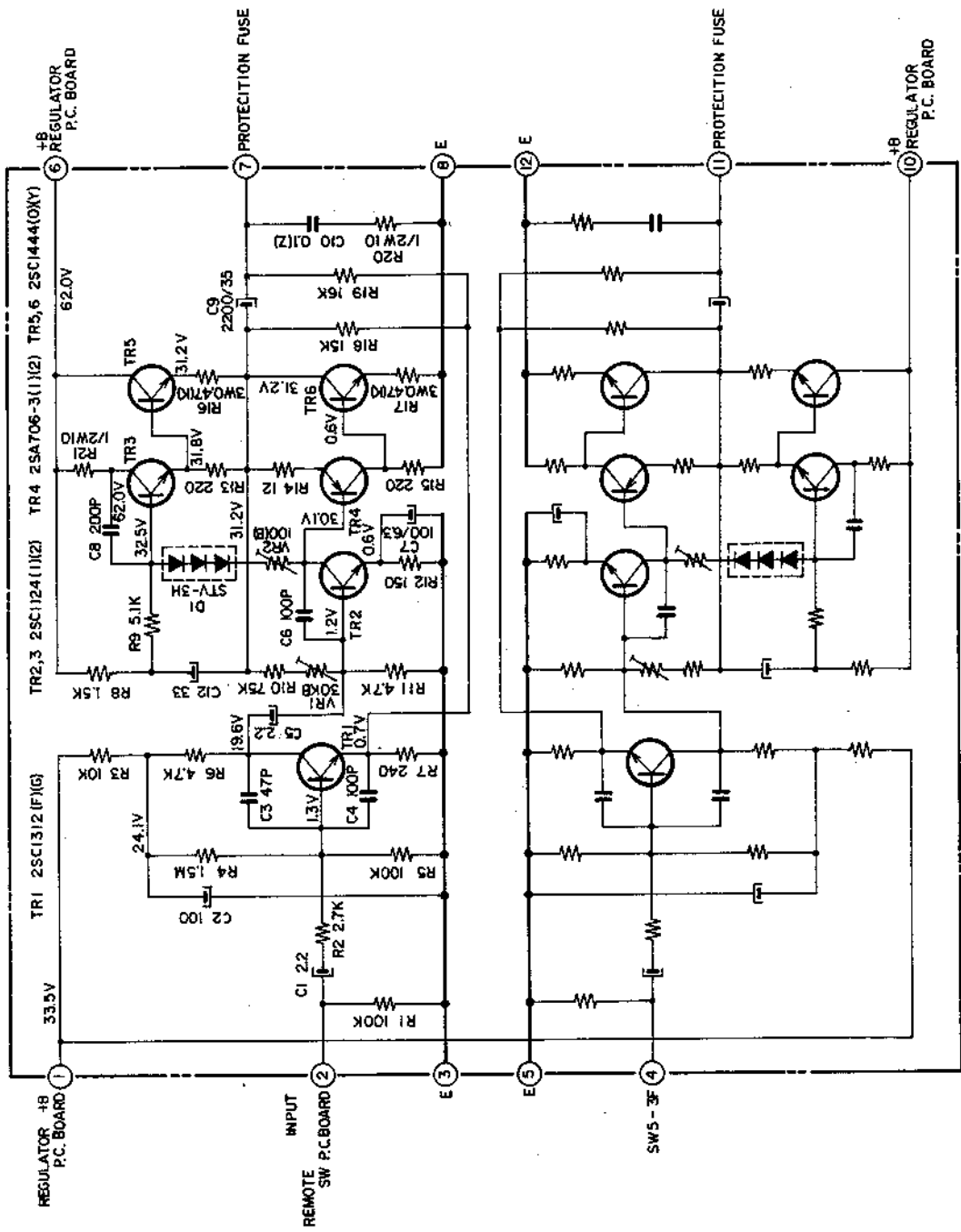

POWER AMP. P.C. BOARD 97-5009

NOTE  
UNLESS OTHERWISE SPECIFIED  
ALL RESISTORS IN  $\Omega$  1/4W (J)  
ALL CAPACITORS IN  $\mu$ F 50W.V. (J)

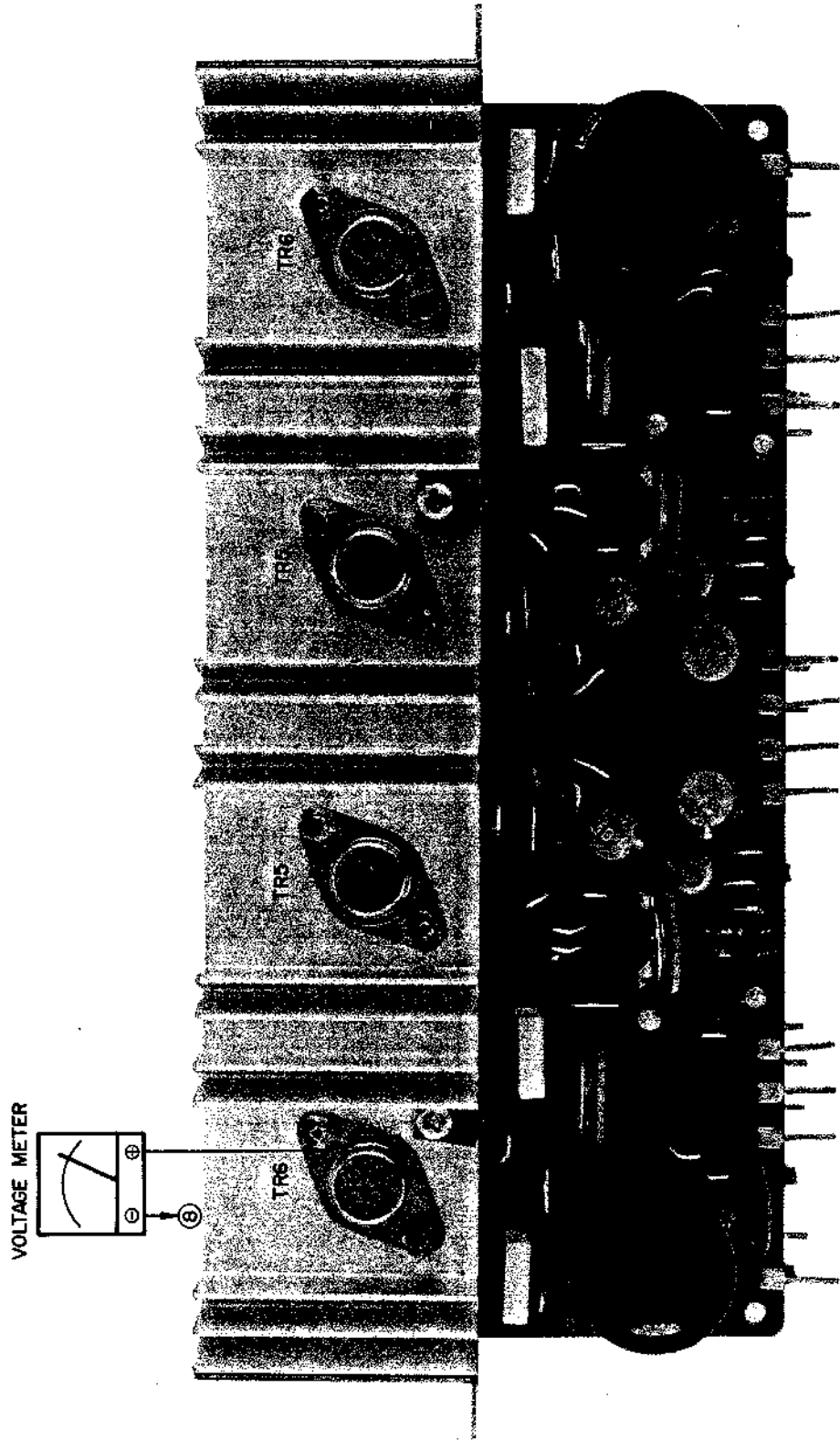

Fig. 22

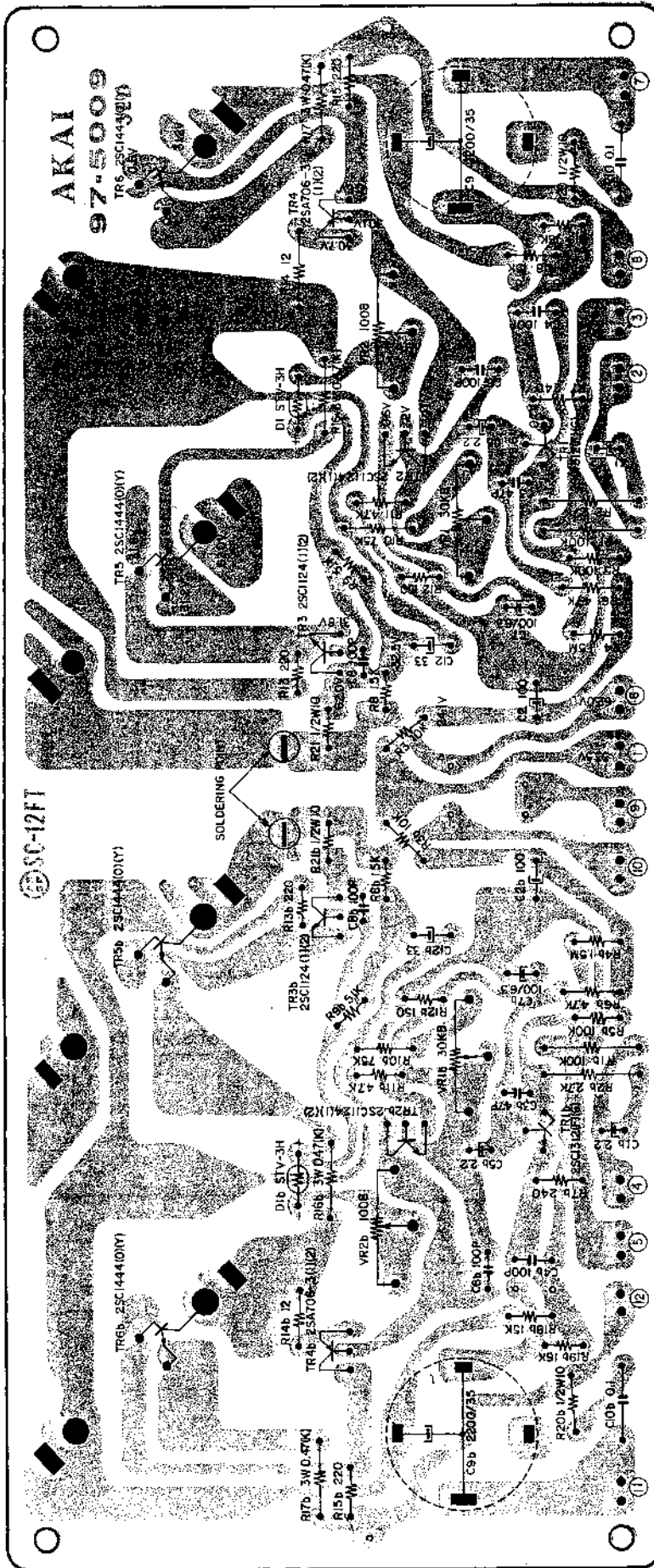
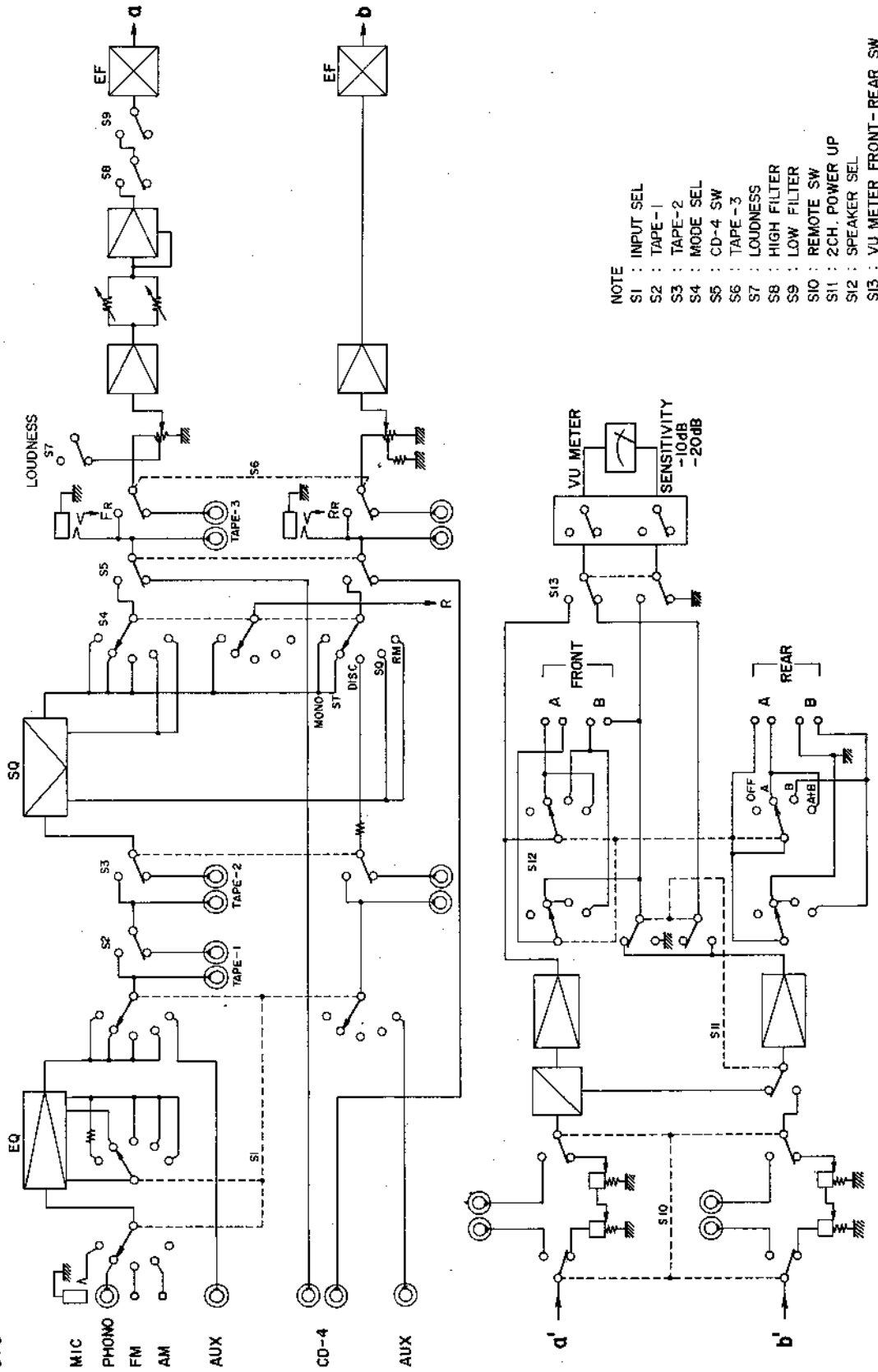

Fig. 23





AS-970. AMP. SECTION BLOCK DIAGRAM  
(LEFT CHANNEL ONLY)

# X. COMPOSITE VIEWS OF COMPONENTS

## 1. SQ P.C. BOARD 97-5010

TR1 to 6, TR1b to 6b 25C1312(F)(G) or 25C458LG(C)

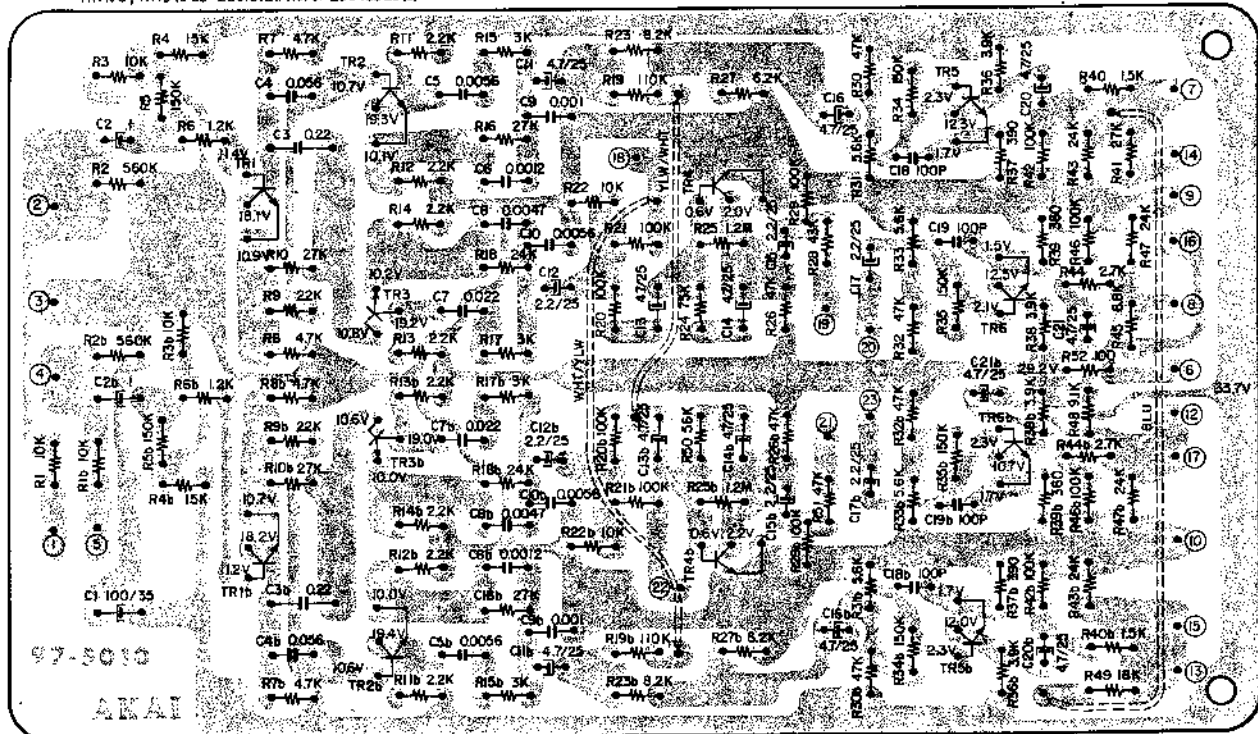

## 2. EQ P.C. BOARD 98-5008

LEFT

RIGHT

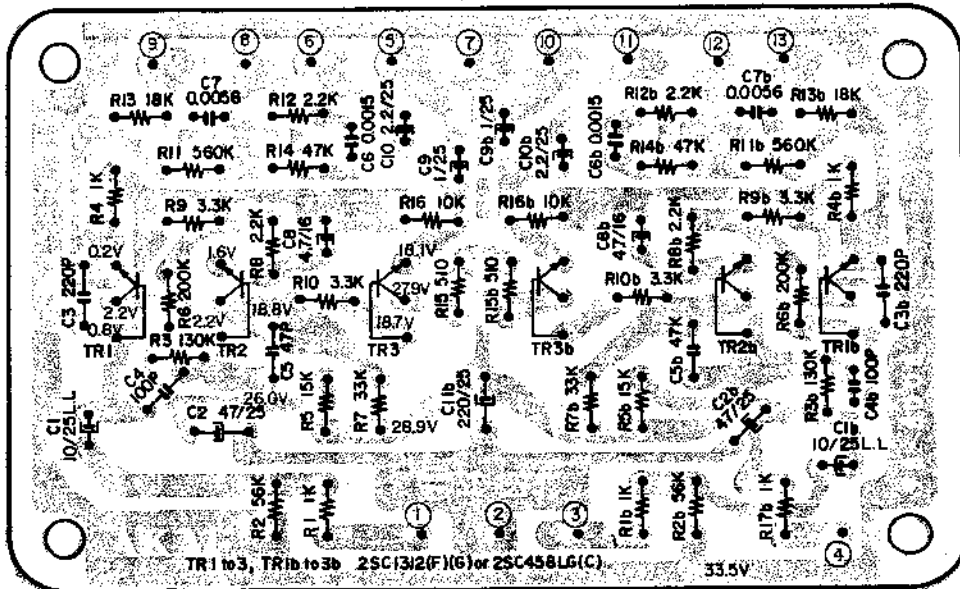

3. TAPE SW. P.C. BOARD 97-5004

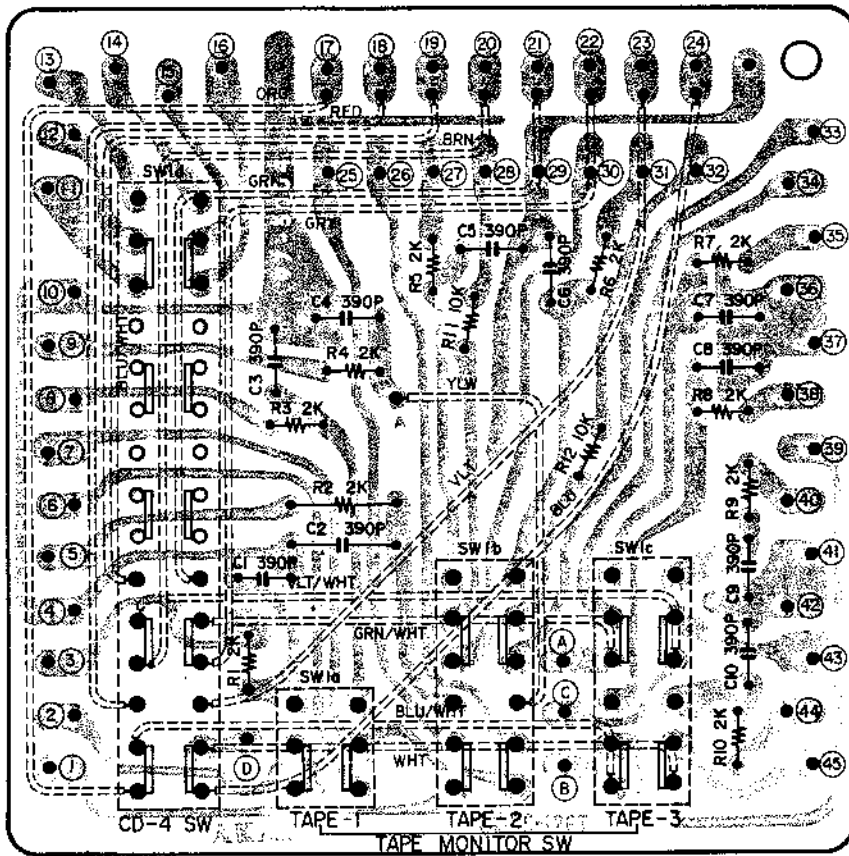

4. VOLUME CONTROL P.C. BOARD 98-5006

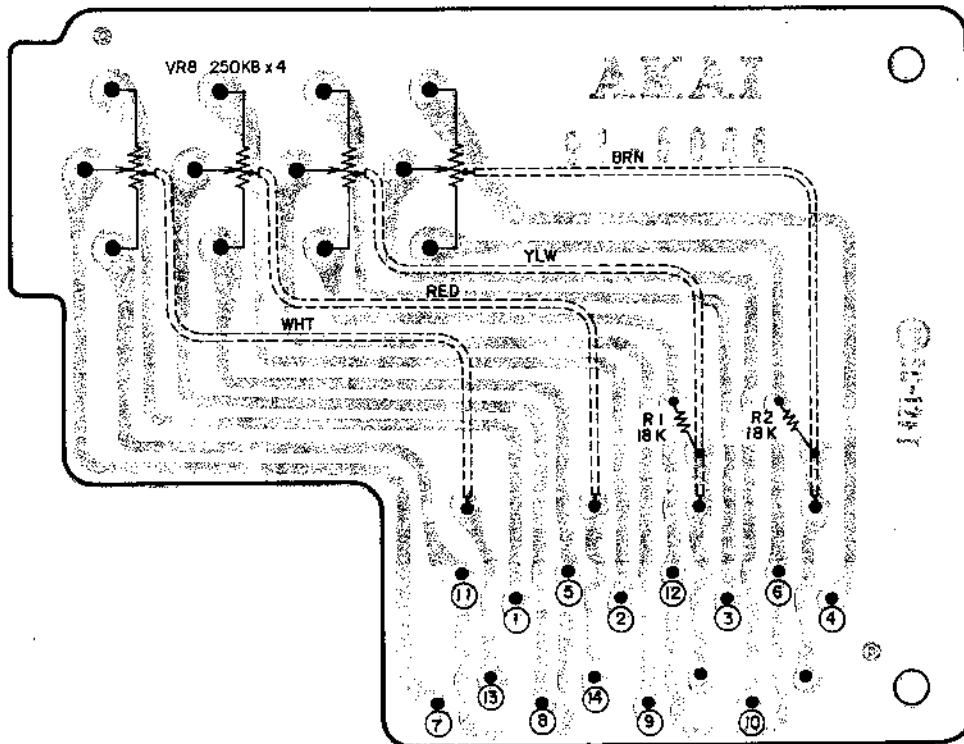

5. BALANCE P.C. BOARD 97-5002

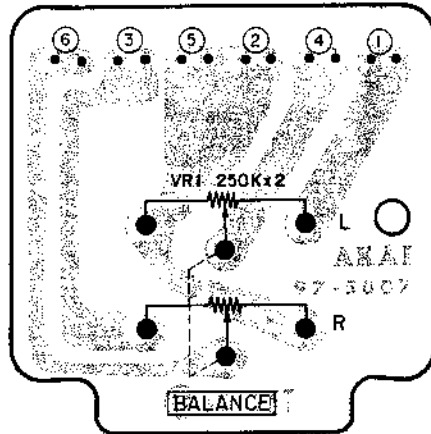

6. TONE CONTROL P.C. BOARD 98-5007

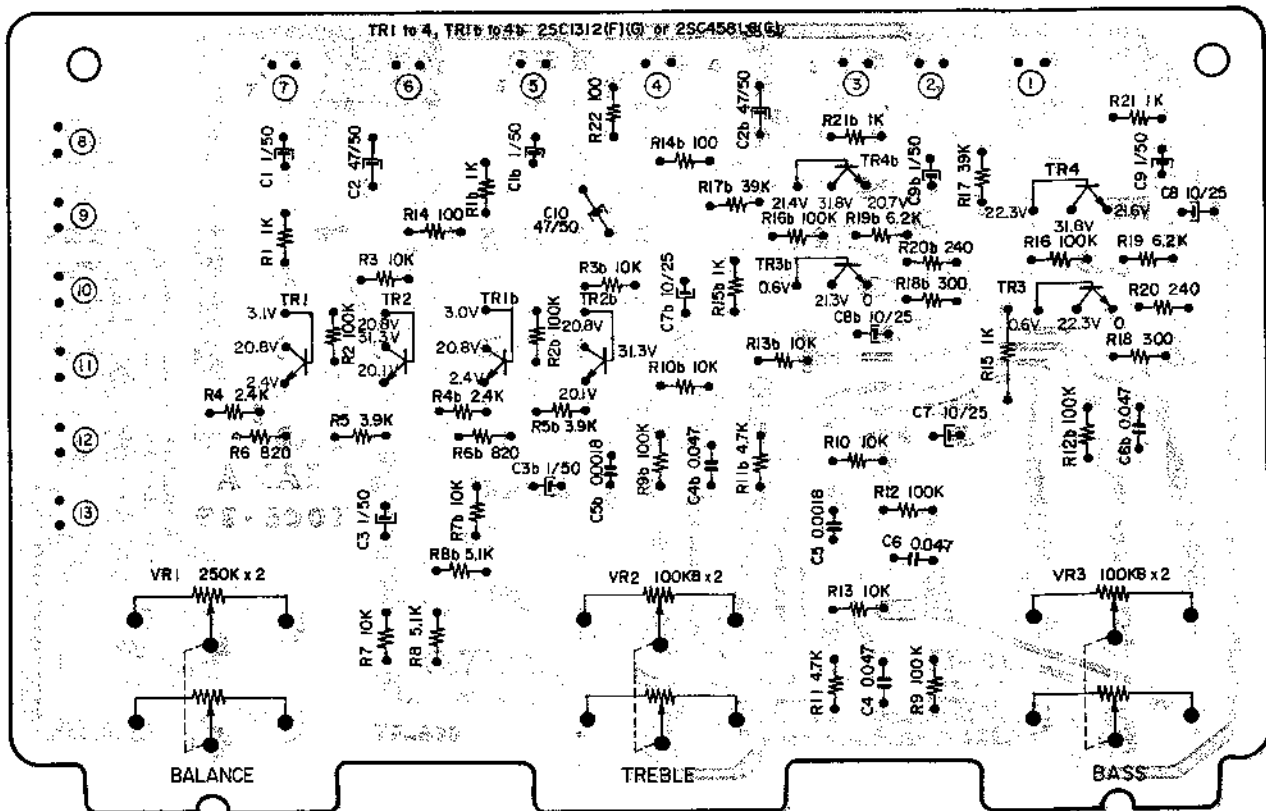

### 7. FILTER P.C. BOARD 97-5005

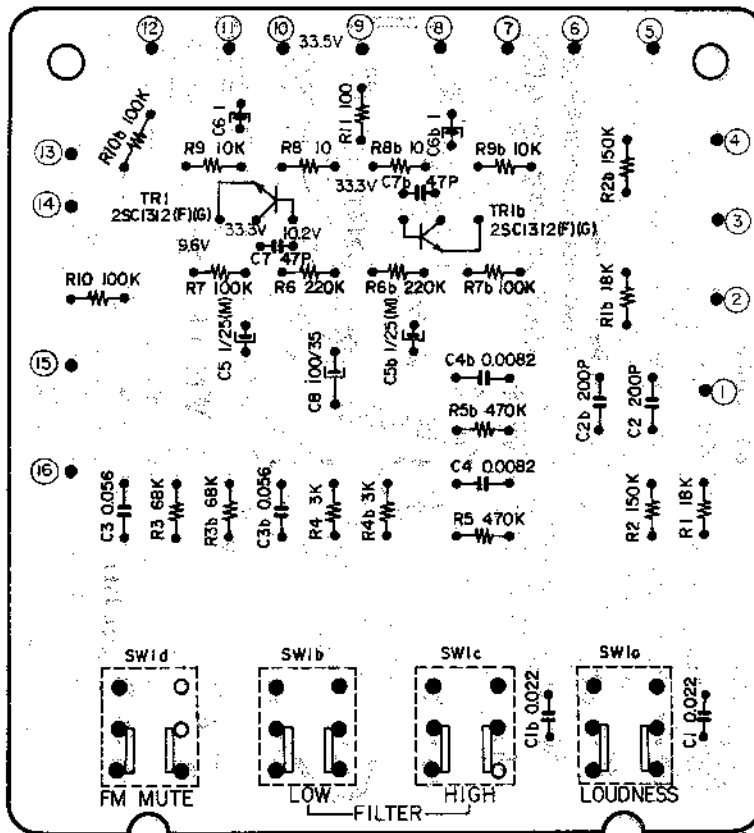

### 8. REMOTE SW. P.C. BOARD 97-5003

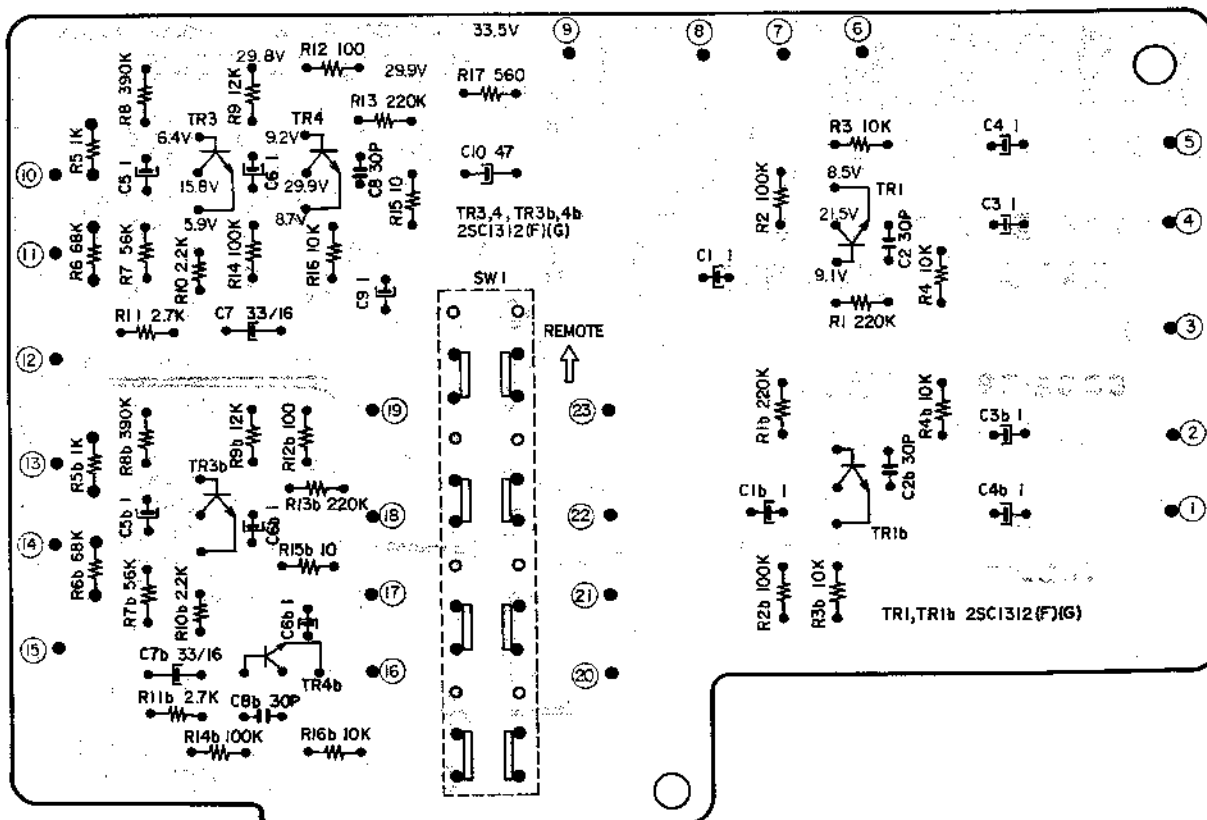

9. METER SW. P.C. BOARD 97-5001

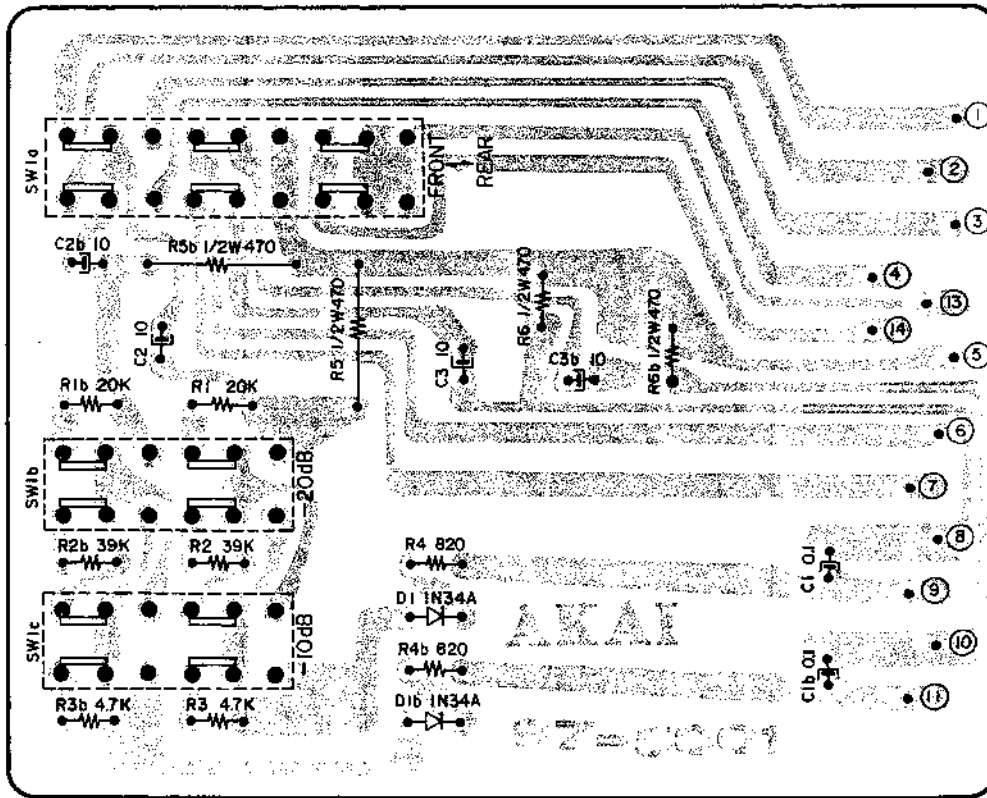

10. REGULATOR P.C. BOARD (8) 98-5084

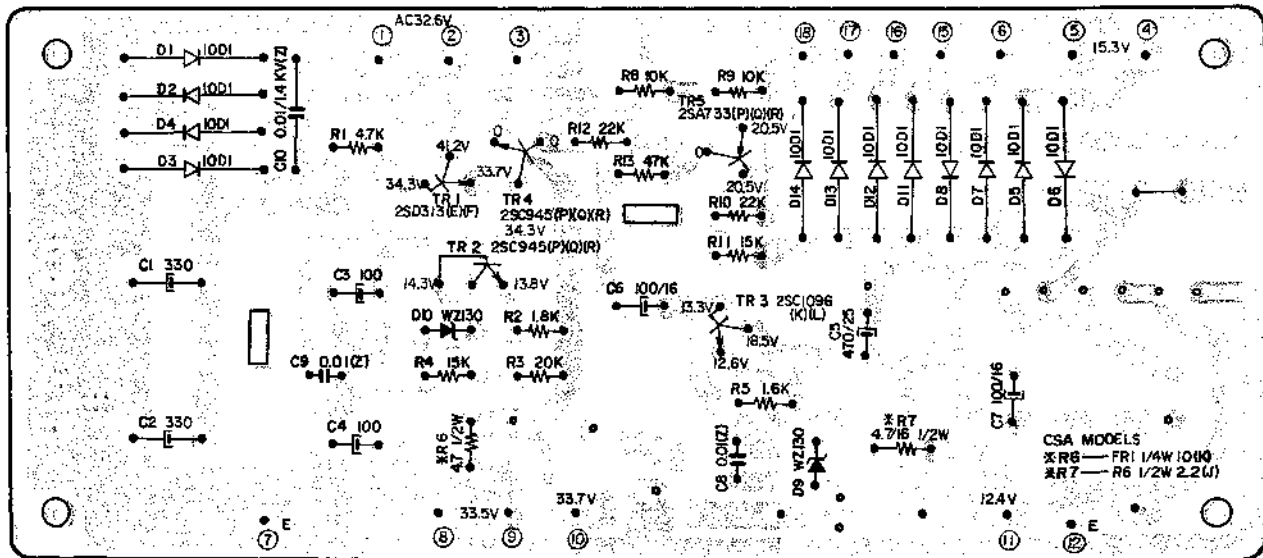

11. RECTIFIER P.C. BOARD (1) 98-5010

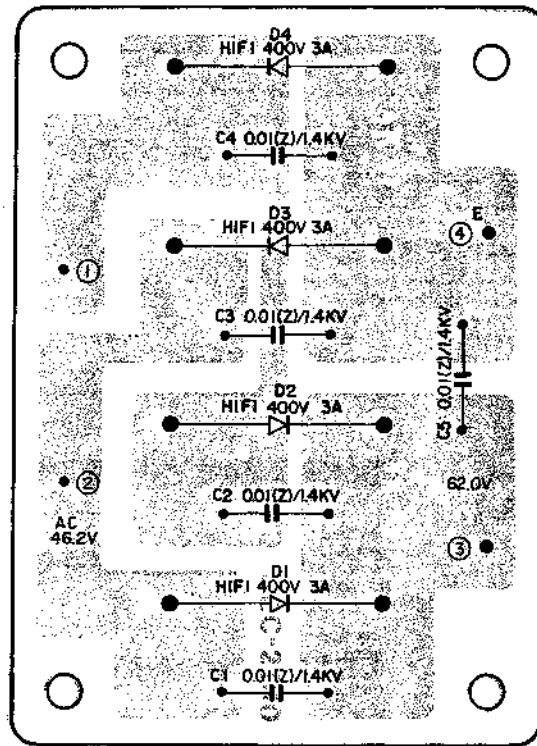

12. RECTIFIER P.C. BOARD (2) 98-5011

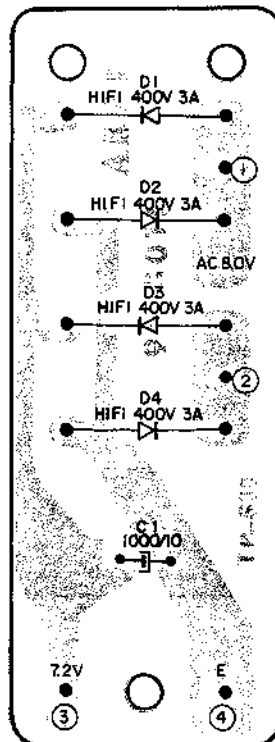

13. HEAD PHONE P.C. BOARD 98-5012

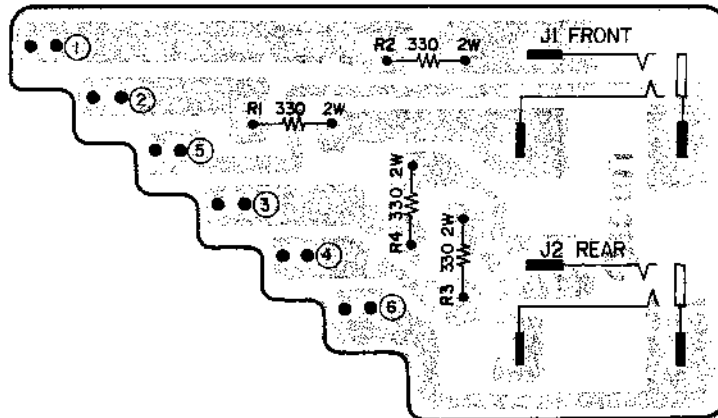

14. MIC. DUB P.C. BOARD 97-5006

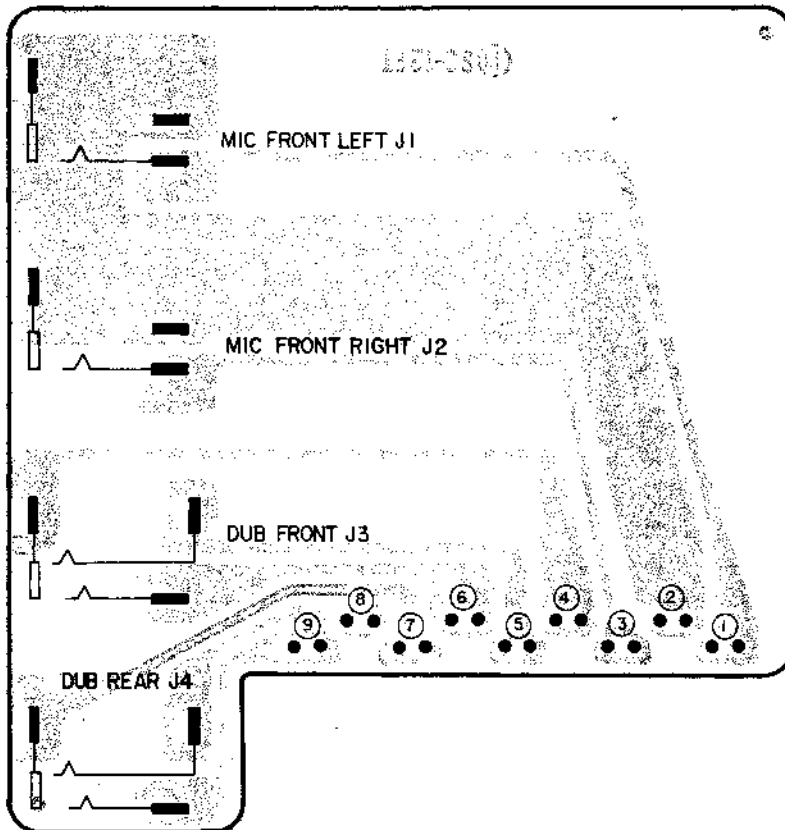



15. DIAL ILLUMINATION P.C. BOARD 97-5008

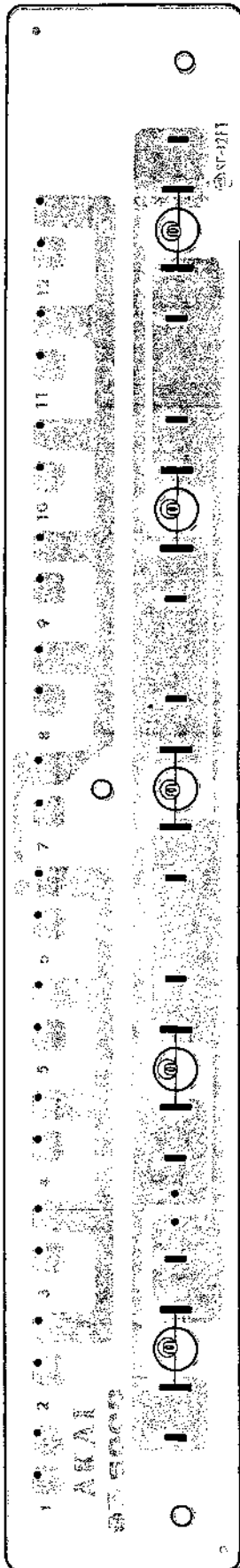

---

SECTION 2

**PARTS LIST**

TABLE OF CONTENTS

Fig. 1	IF P.C. BOARD (94-5009) BLOCK .....	38
Fig. 2	MPX P.C. BOARD (94-5008) BLOCK .....	40
Fig. 3	SQ P.C. BOARD (97-5010) BLOCK .....	41
Fig. 4	MAIN AMP. P.C. BOARD (97-5009) BLOCK .....	42
Fig. 5	EQ P.C. BOARD (98-5008) BLOCK .....	43
Fig. 6	REGULATOR P.C. BOARD (98-5084) BLOCK .....	44
Fig. 7	RECTIFIER P.C. BOARD (1) (98-5010) BLOCK .....	45
Fig. 8	RECTIFIER P.C. BOARD (2) (98-5011) BLOCK .....	45
Fig. 9	TONE CONTROL P.C. BOARD (98-5007) BLOCK .....	46
Fig. 10	VOL. P.C. BOARD (98-5006) BLOCK .....	47
Fig. 11	REMOTE P.C. BOARD (97-5003) BLOCK .....	48
Fig. 12	FILTER P.C. BOARD (97-5005) BLOCK .....	49
Fig. 13	MIC, DUB P.C. BOARD (97-5006) BLOCK .....	50
Fig. 14	HP P.C. BOARD (98-5012) BLOCK .....	51
Fig. 15	METER P.C. BOARD (97-5001) BLOCK .....	52
Fig. 16	TAPE P.C. BOARD (97-5004) BLOCK .....	53
Fig. 17	BALANCE P.C. BOARD (97-5002) BLOCK .....	54
Fig. 18	LAMP. P. C. BOARD (97-5008) BLOCK .....	54
Fig. 19	FRONT CHASSIS BLOCK .....	55
Fig. 20	SCALE MT. PLATE/REAR PANEL BLOCK .....	56
Fig. 21	ASSEMBLY BLOCK .....	58
Fig. 22	FINAL ASSEMBLY BLOCK .....	60
	INDEX .....	61

## HOW TO USE THIS PARTS LIST

1. This parts list is compiled by various individual blocks based on assembly process.
2. When ordering parts, please describe parts number, serial number, and model number in detail.
3. How to read List

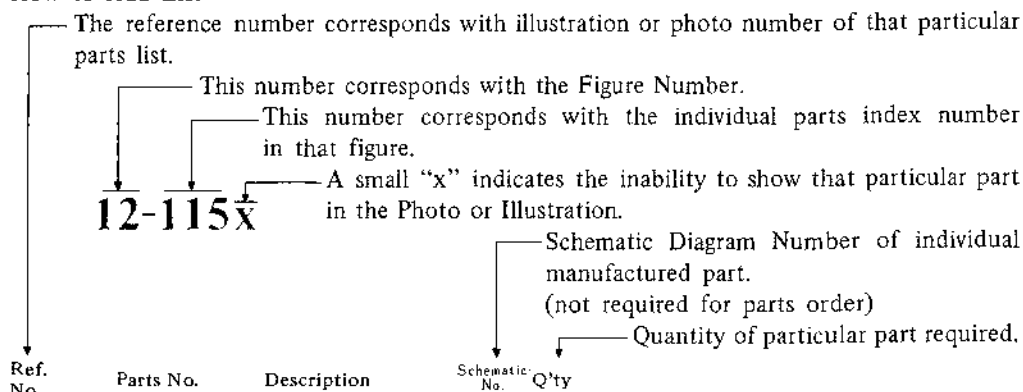

4. The symbol numbers shown on the P.C. Board list can be matched with the Composite Views of Components of the Schematic Diagram or Service Manual.
5. The indications of Resistors and Capacitors in the photos of P.C. Board are being eliminated.
6. The shape of the parts and parts name, etc. can be confirmed by comparing them with the parts shown on the Electrical Parts Table of P.C. Board.
7. Both the kind of part and installation position can be determined by the Parts Number. To determine where a parts number is listed, utilize Parts Index at end of Parts List.  
It is necessary first of all to find the Parts Number. This can be accomplished by using the Reference Number listed at right of parts number in the Parts Index. (meaning of ref. no. outlined in Item 3 above).
8. Utilize separate "Price List for Parts" to determine unit price. The most simple method of finding parts Price is to utilize the reference number.

## ELECTRICAL PARTS TABLE





<p>Because the indication of resistors and capacitors in the P.C. Board photos are being eliminated, please confirm parts name and shape by comparing them with the parts shown in this table.</p>	<p style="text-align: center;">1</p>  <p style="text-align: center;">Solid Resistor</p>	<p style="text-align: center;">2</p> <p style="text-align: right;">Stopper Type</p>  <p style="text-align: center;">Insulator Type</p> <p style="text-align: center;">Carbon Resistor</p>	<p style="text-align: center;">3</p>  <p style="text-align: center;">Metal Oxide Film Resistor</p>
<p style="text-align: center;">4</p>  <p style="text-align: center;">Cement Resistor</p>	<p style="text-align: center;">5</p>  <p style="text-align: center;">Wire-Wound Resistor</p>	<p style="text-align: center;">6</p>  <p style="text-align: center;">Thermister</p>	<p style="text-align: center;">7</p>  <p style="text-align: center;">Enamel Resistor</p>
<p style="text-align: center;">1</p>  <p style="text-align: center;">MP Capacitor (Tubular Type)</p>	<p style="text-align: center;">2</p>  <p style="text-align: center;">Plastic Capacitor</p>	<p style="text-align: center;">3</p>  <p style="text-align: center;">Mylar Capacitor</p>	<p style="text-align: center;">4</p>  <p style="text-align: center;">VFM (Hi-Q) Capacitor</p>
<p style="text-align: center;">5</p>  <p style="text-align: center;">Mylar Capacitor</p>	<p style="text-align: center;">6</p>  <p style="text-align: center;">Tantalum Capacitor</p>	<p style="text-align: center;">7</p>  <p style="text-align: center;">Oil Capacitor (Tubular Type)</p>	<p style="text-align: center;">8</p> <p style="text-align: right;">Vertical Type</p>  <p style="text-align: center;">Tubular Type</p> <p style="text-align: center;">Styrol Capacitor</p>
<p style="text-align: center;">9</p>  <p style="text-align: center;">Electrolytic Capacitor (Tubular Type)</p>	<p style="text-align: center;">10</p> <p style="text-align: right;">Vertical Type</p>  <p style="text-align: center;">Tubular Type</p> <p style="text-align: center;">Electrolytic Capacitor</p>	<p style="text-align: center;">11</p>  <p style="text-align: center;">Ceramic Capacitor</p>	<p style="text-align: center;">12</p>  <p style="text-align: center;">Metalized Mylar (Paper) Capacitor</p>
<p style="text-align: center;">13</p>  <p style="text-align: center;">Trimmer Condenser</p>	<p style="text-align: center;">VR</p>  <p style="text-align: center;">Semi-Fixed Volume</p>		
<p style="text-align: center;">L</p>  <p style="text-align: center;">Ferri Inductor</p>	<p style="text-align: center;">TR</p>  <p style="text-align: center;">Transistor</p>		
<p style="text-align: center;">CR</p>  <p style="text-align: center;">Spark Quencher</p>	<p style="text-align: center;">D</p>  <p style="text-align: center;">Diode (Silicon, Zener, Germanium)</p>		

FIG. 1 PHOTO OF IF P.C. BOARD (94-5009) BLOCK



IF P.C. BOARD (94-5009) BLOCK

Symbol No.	Parts No.	Description	Q'ty
1-1x	BA562320	IF P.C. Board Comp. (94-5009)	1
1-2x	BA563894	IF P.C. Board Comp. (94-5009) (US-B)	1
1-3x	BA562331	IF P.C. Board Comp. (94-5009) (J)	1
1-IC1 to 4	EI469967	I.C LA-1221	4
1-TR1, 2	ET520334	Transistor 2SC922(L)	2
1-TR3 to 7	ET380834	Transistor 2SC711(E)	5
1-TR9 to 11	ET427860	Transistor 2SC839(H)	3
1-D1 to 5	ED428264	Germanium Diode 1N60	5
1-D6, 7	ED379855	Germanium Diode 1N60P	2
1-D8	ED514721	Silicon Diode WG-599	1
1-D9 to 13	ED219464	Germanium Diode 1N34A	5
1-T1	ET551406	Trans. 05M-033-1329	1
1-T2	ED551395	FM Discri Coil 05M-033-1352B	1
1-T4	ED551428	AM-OSC Coil 05M-033-1327	1
1-T5	BT379991	Trans. HI-137S (Yellow)	1
1-T6	BT380384	Trans. HI-134S (White)	1
1-T7	BT443610	Trans. HI-144S (Black)	1
1-FL1 to 3	ER539818	Filter SFE-10.7MAS	3
1-FL4	ER380406	Filter BFB 455B-5	1
1-FL4	ER380417	Filter BFB 464-A	1
1-L1, 2	EO539820	Peaking Coil 2.2μH(K)	2
1-VR1	EV380215	Semi-fixed/Vol. SR19R 100 kB (Solid Type)	1
1-VR2	EV551452	Semi-fixed/Vol. SR19R 22 kB (Solid Type)	1
1-4	EJ539662	Wrapping Post 1x17	19

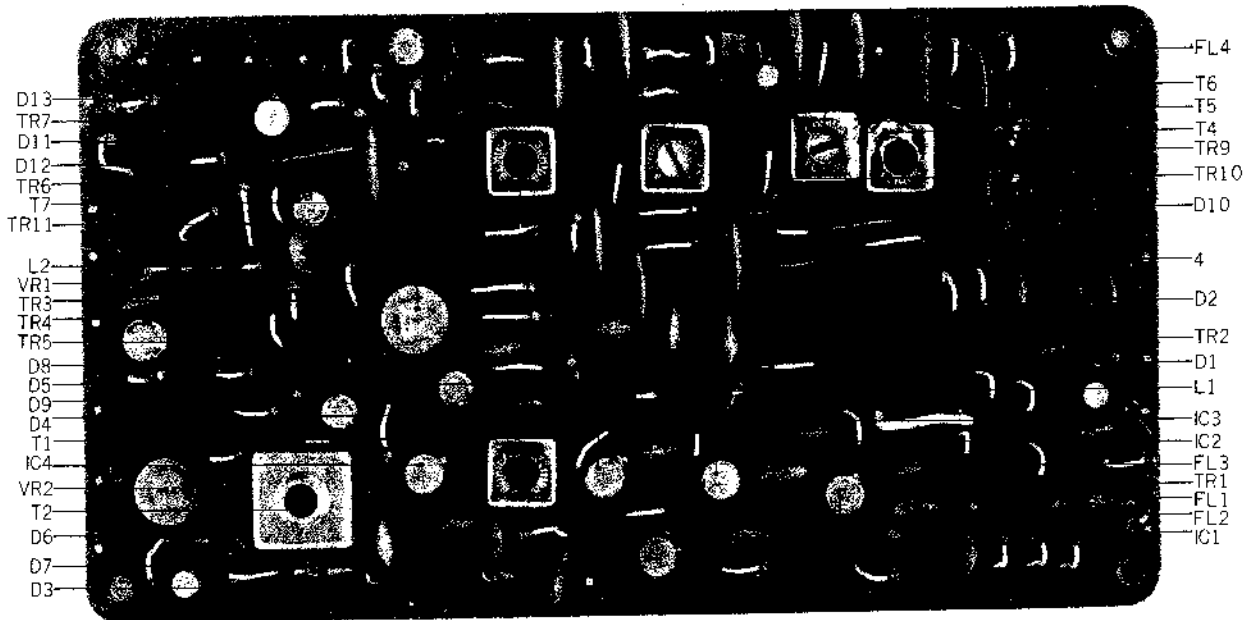
When ordering parts, please describe Parts Number, Serial Number, and Model Number in detail.

Symbol No.	Parts No.	Description	Q'ty	Symbol No.	Parts No.	Description	Q'ty
						<b>Resistor, Stopper Type</b>	
				1-R1	ER211667	Carbon RD1/4 100(J)	1
				1-R2	ER212681	Carbon RD1/4 330(J)	1
				1-R3	ER306887	Carbon RD1/4 15k(J)	1
				1-R4	ER212872	Carbon RD1/4 4.3k(J)	1
				1-R5	ER212681	Carbon RD1/4 330(J)	1
				1-R6	ER211465	Carbon RD1/4 1k(J)	1
				1-R7	ER212883	Carbon RD1/4 4.7k(J)	1
				1-R8	ER306843	Carbon RD1/4 1.2k(J)	1
				1-R9	ER357491	Carbon RD1/4 82k(J)	1
				1-R10	ER306887	Carbon RD1/4 15k(J)	1
				1-R11, 12	ER212681	Carbon RD1/4 330(J)	2
				1-R13	ER304290	Carbon RD1/4 10(J)	1
				1-R14	ER212681	Carbon RD1/4 330(J)	1
				1-R15	ER371946	Carbon RD1/4 2k(J)	1
				1-R16, 17	ER304290	Carbon RD1/4 10(J)	2
				1-R18	ER380913	Carbon RD1/4 33(J)	1
				1-R19	ER399060	Carbon RD1/4 9.1k(J)	1
				1-R20	ER347073	Carbon RD1/4 200(J)	1
				1-R21, 22	ER211465	Carbon RD1/4 1k(J)	2
				1-R23	ER211667	Carbon RD1/4 100(J)	1
				1-R24	ER211858	Carbon RD1/4 12k(J)	1
				1-R25	ER349907	Carbon RD1/4 33k(J)	1
				1-R26	ER211757	Carbon RD1/4 100k(J)	1
				1-R27	ER212264	Carbon RD1/4 22k(J)	1
				1-R28	ER430086	Carbon RD1/4 560k(J)	1
				1-R29	ER349907	Carbon RD1/4 33k(J)	1
				1-R30	ER392850	Carbon RD1/4 390k(J)	1
				1-R31	ER336442	Carbon RD1/4 10k(J)	1
				1-R32	ER212477	Carbon RD1/4 3.3k(J)	1
				1-R33	ER211858	Carbon RD1/4 12k(J)	1
				1-R34	ER212681	Carbon RD1/4 330(J)	1
				1-R35, 36	ER336442	Carbon RD1/4 10k(J)	2
				1-R37	ER357456	Carbon RD1/4 2.2k(J)	1
				1-R38	ER361528	Carbon RD1/4 56k(J)	1
				1-R39	ER349942	Carbon RD1/4 8.2k(J)	1
				1-R40	ER211667	Carbon RD1/4 100(J)	1
				1-R41	ER357456	Carbon RD1/4 2.2k(J)	1
				1-R42	ER211465	Carbon RD1/4 1k(J)	1
				1-R43	ER379517	Carbon RD1/4 62k(J)	1
				1-R44, 45	ER211667	Carbon RD1/4 100(J)	2
				1-R46	ER304402	Carbon RD1/4 470(J)	1
				1-R47	ER211465	Carbon RD1/4 1k(J)	1
				1-R48	ER357535	Carbon RD1/4 39k(J)	1
				1-R49	ER336442	Carbon RD1/4 10k(J)	1
				1-R50	ER304402	Carbon RD1/4 470(J)	1
				1-R51	ER211465	Carbon RD1/4 1k(J)	1
				1-R52, 53	ER211667	Carbon RD1/4 100(J)	2
				1-R54	ER336442	Carbon RD1/4 10k(J)	1
				1-R55	ER304402	Carbon RD1/4 470(J)	1
				1-R56	ER212883	Carbon RD1/4 4.7k(J)	1
				1-R57	ER391961	Carbon RD1/4 91k(J)	1
				1-R58	ER357456	Carbon RD1/4 2.2k(J)	1
1-C1 to 3	EC551441	Capacitor, Vertical Type Ceramic DD600YM 0.01 $\mu$ F(Z) 50WV	3				
1-C4	EC368256	Elect. 0.47 $\mu$ F 25WV	1				
1-C5 to 7	EC551441	Ceramic DD600YM 0.01 $\mu$ F(Z) 50WV	3				
1-C8	EC419231	VFM 12PF(J) 50WV	1				
1-C9 to 17	EC551441	Ceramic DD600YM 0.01 $\mu$ F(Z) 50WV	9				
1-C18	EC336104	Elect. 100 $\mu$ F 6.3WV	1				
1-C19, 20	EC551441	Ceramic DD600YM 0.01 $\mu$ F(Z) 50WV	2				
1-C21, 22	EC336216	VFM 330PF(J) 50WV	2				
1-C23	EC450527	Elect. 4.7 $\mu$ F 25WV	1				
1-C24	EC336216	VFM 330PF(J) 50WV	1				
1-C25	EC329771	Elect. 47 $\mu$ F 6.3WV	1				
1-C26	EC313108	Elect. 1 $\mu$ F 50WV	1				
1-C27	EC290531	VFM 100PF(K) 50WV	1				
1-C28, 29	EC551441	Ceramic DD600YM 0.01 $\mu$ F(Z) 50WV	2				
1-C30	EC313108	Elect. 1 $\mu$ F 50WV	1				
1-C31, 32	EC551441	Ceramic DD600YM 0.01 $\mu$ F(Z) 50WV	2				
1-C33	EC450527	Elect. 4.7 $\mu$ F 25WV	1				
1-C34	EC492142	Ceramic DD512YM 0.047 $\mu$ F(Z) 50WV	1				
1-C35	EC250841	Mylar 0.01 $\mu$ F(J) 50WV	1				
1-C36	EC423562	VFM 470PF(J) 50WV	1				
1-C37	EC419231	VFM 12PF(J) 50WV	1				
1-C38 to 42	EC492142	Ceramic DD512YM 0.047 $\mu$ F(Z) 50WV	5				
1-C43	EC320051	Elect. 10 $\mu$ F 16WV	1				
1-C44 to 47	EC492142	Ceramic DD512YM 0.047 $\mu$ F(Z) 50WV	4				
1-C48	EC329850	VFM 220PF(J) 50WV	1				
1-C49, 50	EC250841	Mylar 0.01 $\mu$ F(J) 50WV	2				
1-C51	EC492142	Ceramic DD512YM 0.047 $\mu$ F(Z) 50WV	1				
1-C52	EC450527	Elect. 4.7 $\mu$ F 25WV	1				
1-C53	EC492142	Ceramic DD512YM 0.047 $\mu$ F(Z) 50WV	1				
1-C54	EC336104	Elect. 100 $\mu$ F 6.3WV	1				

When ordering parts, please describe Parts Number, Serial Number, and Model Number in detail.

FIG. 2 PHOTO OF MPX P.C. BOARD (94-5008) BLOCK

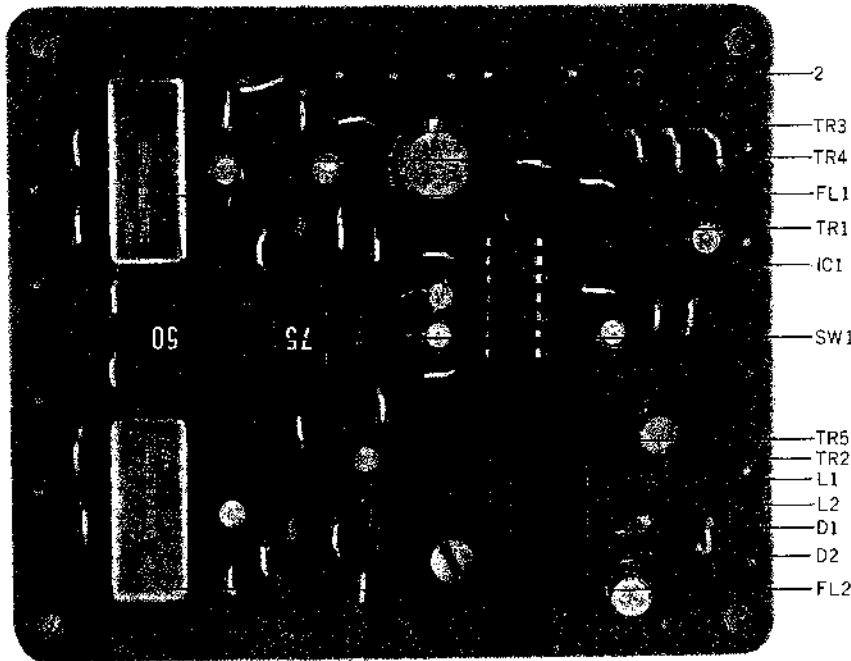

MPX P.C. BOARD (94-5008) BLOCK

Symbol No.	Parts No.	Description	Q'ty	Symbol No.	Parts No.	Description	Q'ty
2-1x	BA574795	MPX P.C. Board Comp. (94-5008)	1	<b>Resistor, Stopper Type</b>			
2-IC1	EI443744	LC LA-3300	1	2-R1	ER346994	Carbon RD1/4 18k(J)	1
2-TR1	ET552870	FET 2SK30 (Y) (GR)	1	2-R2	ER357491	Carbon RD1/4 82k(J)	1
2-TR2, 3	ET453486	Transistor 2SC711 (E) (F)	2	2-R3	ER496214	Carbon RD1/4 360k(J)	1
2-TR4, 5	ET539987	Transistor 2SC1312(F) (G)	2	2-R4	ER419040	Carbon RD1/4 1M(J)	1
2-D1, 2	EO219464	Germanium Diode 1N34A	2	2-R5	ER357491	Carbon RD1/4 82k(J)	1
2-L1	EO443766	Coil (19KC) 02-1070-03 1070 (Black)	1	2-R6	ER496214	Carbon RD1/4 360k(J)	1
2-L2	EO443777	Coil (38KC) 02-1064-03 1064 (White)	1	2-R7	ER336442	Carbon RD1/4 10k(J)	1
2-FL1, 2	ER512201	Filter FB-24	2	2-R8	ER211465	Carbon RD1/4 1k(J)	1
2-SW1	ES513922	Slide SW. SSB02242	1	2-R9, 10	ER343078	Carbon RD1/4 2.7k(J)	2
2-2	EJ539662	Wrapping Post 1x17	15	2-R11	ER357456	Carbon RD1/4 2.2k(J)	1
<b>Capacitor, Vertical Type</b>				2-R12, 13	ER346601	Carbon RD1/4 47k(J)	2
2-C1	EC331828	Elect. 3.3μF 25WV	1	2-R14, 15	ER211465	Carbon RD1/4 1k(J)	2
2-C2	EC250841	Mylar 0.01μF(J) 50WV	1	2-R16 to 19	ER380711	Carbon RD1/4 220k(J)	4
2-C3	EC313244	Elect. 1μF 16WV	1	2-R20, 21	ER212883	Carbon RD1/4 4.7k(J)	2
2-C4	EC331828	Elect. 3.3μF 25WV	1	2-R22, 23	ER371946	Carbon RD1/4 2k(J)	2
2-C5	EC339096	Elect. 470μF 16WV	1	2-R24	ER212681	Carbon RD1/4 330(J)	1
2-C6	EC389474	Mylar 0.0015μF(J) 50WV	1	2-R25, 26	ER212883	Carbon RD1/4 4.7k(J)	2
2-C7	EC350706	Elect. 4.7μF 16WV	1	2-R27, 28	ER346601	Carbon RD1/4 47k(J)	2
2-C8, 9	EC220432	Elect. 2.2μF 25WV	2	2-R29, 30	ER357535	Carbon RD1/4 39k(J)	2
2-C10, 11	EC337500	Mylar 0.0047μF(J) 50WV	2				
2-C12, 13	EC250975	Mylar 0.015μF(J) 50WV	2				
2-C14, 15	EC220432	Elect. 2.2μF 25WV	2				
2-C16, 17	EC551463	Ceramic DD600YW 0.001μF (Z) 50WV	2				
2-C18, 19	EC350706	Elect. 4.7μF 16WV	2				
2-C20, 21	EC380621	Mylar 0.0068μF(J) 50WV	2				

When ordering parts, please describe Parts Number, Serial Number, and Model Number in detail.

FIG. 3 PHOTO OF SQ P.C. BOARD (97-5010) BLOCK

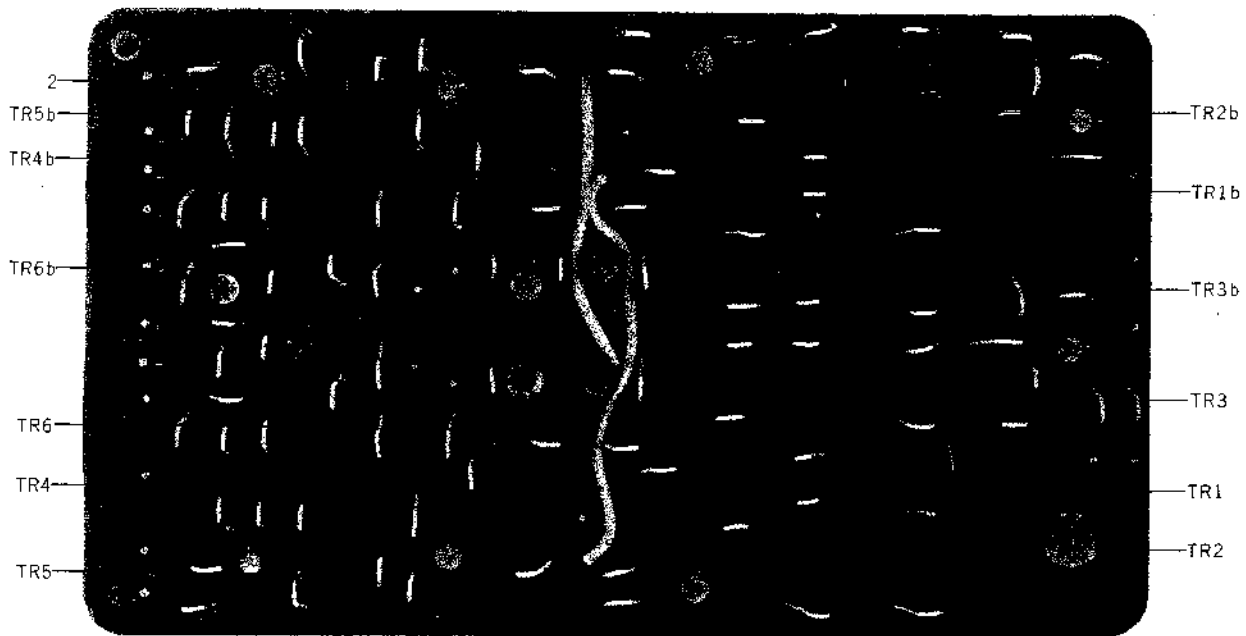

SQ P.C. BOARD (97-5010) BLOCK

Symbol No.	Parts No.	Description	Q'ty	Symbol No.	Parts No.	Description	Q'ty
3-1x	BA562342	SQ P.C. Board Comp. (97-5010)	1	3-R15	ER346544	Carbon RD1/4 3k(J)	2
3-TR1 to 6	ET539987	Transistor 2SC1312 (F) (G)	12	3-R16	ER342933	Carbon RD1/4 27k(J)	2
3-2	EJ539662	Wrapping Post 1x17	22	3-R17	ER346544	Carbon RD1/4 3k(J)	2
<b>Capacitor, Vertical Type</b>				3-R18	ER407316	Carbon RD1/4 24k(J)	2
3-C1	EC455354	Elect. 100 $\mu$ F 35WV	1	3-R19	ER379552	Carbon RD1/4 110k(J)	2
3-C2	EC313108	Elect. 1 $\mu$ F 50WV	2	3-R20, 21	ER211757	Carbon RD1/4 100k(J)	4
3-C3	EC538435	Mylar 0.22 $\mu$ F (J) 50WV	2	3-R22	ER336442	Carbon RD1/4 10k(J)	2
3-C4	EC368357	Mylar 0.056 $\mu$ F (J) 50WV	2	3-R23	ER349942	Carbon RD1/4 8.2k(J)	2
3-C5	EC329883	Mylar 0.0056 $\mu$ F (J) 50WV	2	3-R24	ER362520	Carbon RD1/4 75k(J)	1
3-C6	EC379721	Mylar 0.0012 $\mu$ F (J) 50WV	2	3-R25	ER423753	Carbon RD1/4 1.2M(J)	2
3-C7	EC368335	Mylar 0.022 $\mu$ F (J) 50WV	2	3-R26	ER346601	Carbon RD1/4 47k(J)	2
3-C8	EC337500	Mylar 0.0047 $\mu$ F (J) 50WV	2	3-R27	ER380755	Carbon RD1/4 6.2k(J)	2
3-C9	EC350875	Mylar 0.001 $\mu$ F (J) 50WV	2	3-R28	ER419556	Carbon RD1/4 43k(J)	1
3-C10	EC329883	Mylar 0.0056 $\mu$ F (J) 50WV	2	3-R29	ER211757	Carbon RD1/4 100k(J)	2
3-C11	EC450527	Elect. 4.7 $\mu$ F 25WV	2	3-R30	ER346601	Carbon RD1/4 47k(J)	2
3-C12	EC522551	Tantalum 2.2 $\mu$ F (M) 25WV (Dts Type)	2	3-R31	ER213030	Carbon RD1/4 5.6k(J)	2
3-C13, 14	EC450527	Elect. 4.7 $\mu$ F 25WV	4	3-R32	ER346601	Carbon RD1/4 47k(J)	2
3-C15	EC522551	Tantalum 2.2 $\mu$ F (M) 25WV (Dts Type)	2	3-R33	ER213030	Carbon RD1/4 5.6k(J)	2
3-C16	EC450527	Elect. 4.8 $\mu$ F 25WV	2	3-R34, 35	ER357570	Carbon RD1/4 150k(J)	4
3-C17	EC522551	Tantalum 2.2 $\mu$ F (M) 25WV	2	3-R36	ER352045	Carbon RD1/4 3.9k(J)	2
3-C18, 19	EC290520	VFM 100PF (J) 50WV	4	3-R37	ER349784	Carbon RD1/4 390(J)	2
3-C20, 21	EC450527	Elect. 4.7 $\mu$ F 25WV	4	3-R38	ER352045	Carbon RD1/4 3.9k(J)	2
<b>Resistor, Stopper Type</b>				3-R39	ER381723	Carbon RD1/4 360(J)	2
3-R1	ER336442	Carbon RD1/4 10k(J)	2	3-R40	ER211320	Carbon RD1/4 1.5k(J)	2
3-R2	ER430086	Carbon RD1/4 560k(J)	2	3-R41	ER342933	Carbon RD1/4 27k(J)	1
3-R3	ER336442	Carbon RD1/4 10k(J)	2	3-R42	ER211757	Carbon RD1/4 100k(J)	2
3-R4	ER306887	Carbon RD1/4 15k(J)	2	3-R43	ER407316	Carbon RD1/4 24k(J)	2
3-R5	ER357570	Carbon RD1/4 150k(J)	2	3-R44	ER343078	Carbon RD1/4 2.7k(J)	2
3-R6	ER306843	Carbon RD1/4 1.2k(J)	2	3-R45	ER306360	Carbon RD1/4 6.8k(J)	1
3-R7, 8	ER212883	Carbon RD1/4 4.7k(J)	4	3-R46	ER211757	Carbon RD1/4 100k(J)	2
3-R9	ER212264	Carbon RD1/4 22k(J)	2	3-R47	ER407316	Carbon RD1/4 24k(J)	2
3-R10	ER342933	Carbon RD1/4 27k(J)	2	3-R48	ER399060	Carbon RD1/4 9.1k(J)	1
3-R11 to 14	ER357456	Carbon RD1/4 2.2k(J)	8	3-R49	ER346994	Carbon RD1/4 18k(J)	1
				3-R50	ER361528	Carbon RD1/4 56k(J)	1
				3-R51	ER346601	Carbon RD1/4 47k(J)	1
				3-R52	ER211667	Carbon RD1/4 100(J)	1

When ordering parts, please describe Parts Number, Serial Number, and Model Number in detail.



FIG. 4 PHOTO OF MAIN AMP. P.C. BOARD (97-5009) BLOCK

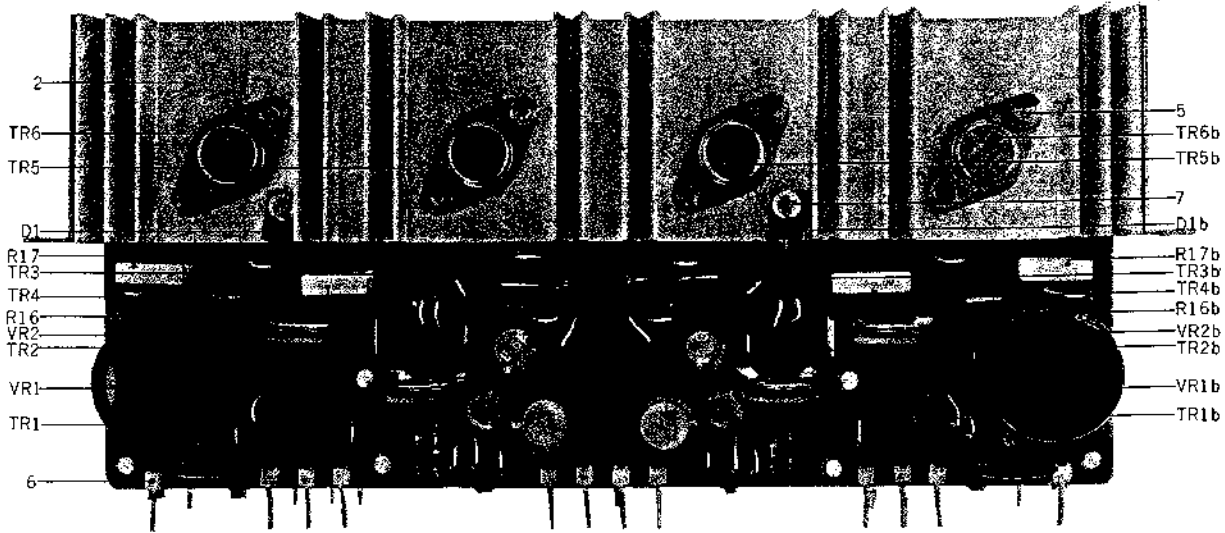

MAIN AMP. P.C. BOARD (97-5009) BLOCK

Symbol No.	Parts No.	Description	Q'ty	Symbol No.	Parts No.	Description	Q'ty
4-1x	BA570903	Main Amp. P.C. Board Comp. (97-5009)	1	<b>Resistor, Stopper Type</b>			
4-TR1	ET539987	Transistor 2SC1312 (F) (G)	2	4-R1	ER213715	Carbon RD1/4 100k (J) (Insu. Type)	2
4-TR2, 3	ET551564	Transistor 2SC1124 (1) (2)	4	4-R2	ER334923	Carbon RD1/4 2.7k (J) (Insu. Type)	2
4-TR4	ET556020	Transistor 2SA706-3 (1) (2)	2	4-R3	ER336442	Carbon RD1/4 10k (J)	2
4-TR5, 6	ET562048	Transistor 2SC1444 (O) (Y)	4	4-R4	ER430007	Carbon RD1/4 1.5M (J)	2
4-D1	ED556514	Varistor STV-3H	2	4-R5	ER211757	Carbon RD1/4 100k(J)	2
4-VR1	EV383398	Semi-fixed/Vol. V18K3-2 30 kB (4US)	2	4-R6	ER212883	Carbon RD1/4 4.7k (J)	2
4-VR2	EV409858	Semi-fixed/Vol. V18K3-2 100B (4US)	2	4-R7	ER406912	Carbon RD1/4 240 (J)	2
4-2	AA542992	Heat-sink C	1	4-R8	ER211320	Carbon RD1/4 1.5k (J)	2
4-3x	AA545624	Transistor Mt. Plate	4	4-R9	ER324202	Carbon RD1/4 5.1k (J)	2
4-4x	ZW259503	Washer (Nylon) D3.1x8x0.5t	16	4-R10	ER362520	Carbon RD1/4 75k (J)	2
4-5	ZS564390	ISO Screw, binding head 3x16	16	4-R11	ER212883	Carbon RD1/4 4.7k (J)	2
4-6	EJ550012	Wrapping Terminal T5280	12	4-R12	ER212016	Carbon RD1/4 150 (J)	2
4-7	ZS321298	ISO Screw, binding head 3x8	2	4-R13	ER357412	Carbon RD1/4 220 (J)	2
4-8x	ZW426622	Washer (SPC) D3.4x7.8x0.5t	2	4-R14	ER407103	Carbon RD1/4 12 (J)	2
		<b>Capacitor, Vertical Type</b>		4-R15	ER357412	Carbon RD1/4 220 (J)	2
4-C1	EC354947	Elect. 2.2μF 50WV	2	4-R16, 17	ER556064	Metal Plate MPC71F2 5W 0.47(K)	4
4-C2	EC321221	Elect. 100μF 50WV	2	4-R18	ER306887	Carbon RD1/4 15k (J)	2
4-C3	EC377212	VFM 47PF(J) 50WV	2	4-R19	ER379596	Carbon RD1/4 16k (J)	2
4-C4	EC290520	VFM 100PF(J) 50WV	2	4-R20	ER452542	Carbon RD1/2 10 (J) (Insu. Type)	2
4-C5	EC364947	Elect. 2.2μF 50WV	2	4-R21	ER551632	Carbon RD1/2 10 (J) (Insu. Type)	2
4-C6	EC290520	VFM 100PF(J) 50WV	2				
4-C7	EC336104	Elect. 100μF 6.3WV	2				
4-C8	EC389237	VFM 200PF(J) 50WV	2				
4-C9	EC556176	Elect. 2200μF 35WV (Lug. Type)	2				
4-C10	EC228745	Ceramic DB209YZ 0.1μF(Z)50WV	2				
4-C12	EC373296	Elect. 33μF 50WV	2				

When ordering parts, please describe Parts Number, Serial Number, and Model Number in detail.

FIG. 5 PHOTO OF EQ P.C. BOARD (98-5008) BLOCK

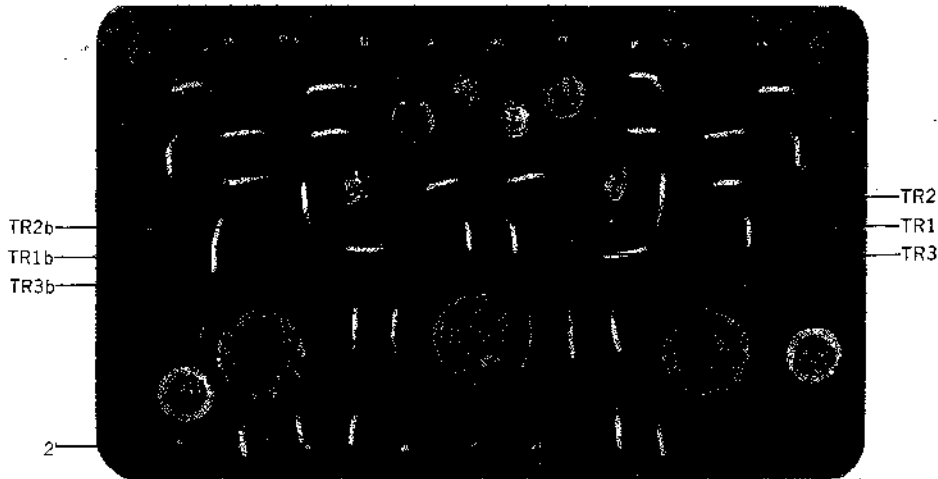

EQ. P.C. BOARD (98-5008) BLOCK

Symbol No.	Parts No.	Description	Q'ty
5-1x	BA560654	EQ. P.C. Board Comp. (98-5008)	1
5-TR1, 2, 3	ET539987	Transistor 2SC1312 (F) (G)	6
5-2	EJ539662	Wrapping Post 1x17	13
<b>Capacitor, Vertical Type</b>			
5-C1	EC517138	Elect. 10 $\mu$ F 25WV NL	2
5-C2	EC220678	Elect. 47 $\mu$ F 25WV	2
5-C3	EC329850	VFM 220PF (J) 50WV	2
5-C4	EC290520	VFM 100PF (J) 50WV	2
5-C5	EC377212	VFM 47PF (J) 50WV	2
5-C6	EC389474	Mylar 0.0015 $\mu$ F (J) 50WV	2
5-C7	EC329883	Mylar 0.0056 $\mu$ F (J) 50WV	2
5-C8	EC350706	Elect. 4.7 $\mu$ F 16WV	2
5-C9	EC450055	Elect. 1 $\mu$ F 25WV	2
5-C10	EC220432	Elect. 2.2 $\mu$ F 25WV	2
5-C11	EC313121	Elect. 220 $\mu$ F 25WV	2
<b>Resistor, Stopper Type</b>			
5-R1	ER211465	Carbon RD1/4 1k (J)	2
5-R2	ER361528	Carbon RD1/4 56k (J)	2
5-R3	ER211950	Carbon RD1/4 130k(J)	2
5-R4	ER211465	Carbon RD1/4 1k(J)	2
5-R5	ER306887	Carbon RD1/4 15k(J)	2
5-R6	ER362272	Carbon RD1/4 200k(J)	2
5-R7	ER349907	Carbon RD1/4 33k(J)	2
5-R8	ER357456	Carbon RD1/4 2.2k(J)	2
5-R9, 10	ER212477	Carbon RD1/4 3.3k(J)	4
5-R11	ER430086	Carbon RD1/4 560k(J)	2
5-R12	ER357456	Carbon RD1/4 2.2k(J)	2
5-R13	ER346994	Carbon RD1/4 18k(J)	2
5-R14	ER346601	Carbon RD1/4 47k(J)	2
5-R15	ER213096	Carbon RD1/4 510(J)	2
5-R16	ER336442	Carbon RD1/4 10k(J)	2
5-R17	ER211465	Carbon RD1/4 1k(J)	2

When ordering parts, please describe Parts Number, Serial Number, and Model Number in detail.

FIG. 6 PHOTO OF REGULATOR P.C. BOARD (98-5084) BLOCK

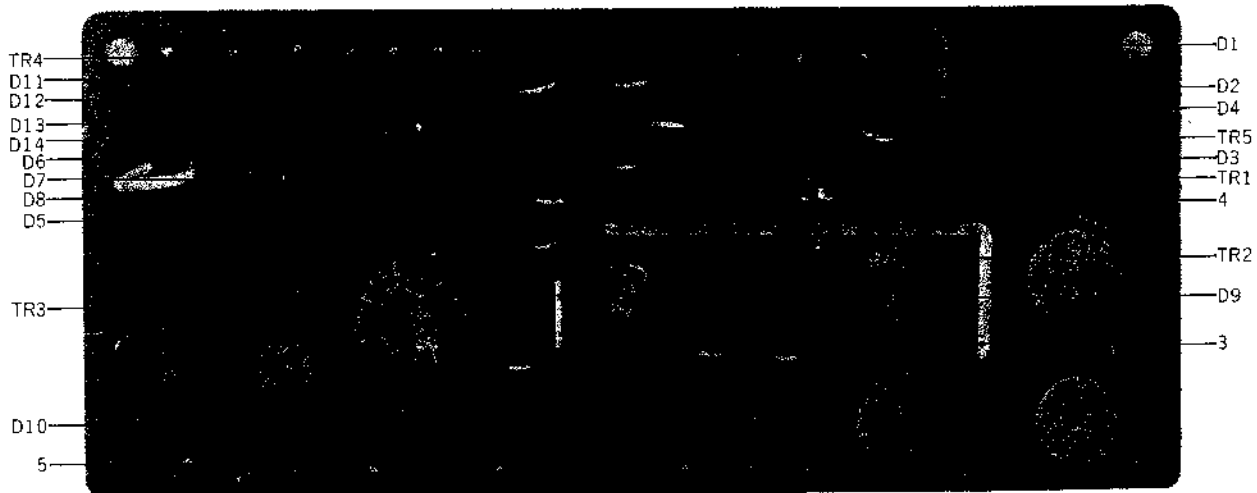

REGULATOR P.C. BOARD (98-5084) BLOCK

Symbol No.	Parts No.	Description	Q'ty
6-1x	BA570396	Regulator P.C. Board Comp. (98-5084)	1
6-2x	BAS70453	Regulator P.C. Board Comp. (98-5084) (CSA)	1
6-TR1	ET452531	Transistor 2SD313 (E) (F)	1
6-TR2	ET517994	Transistor 2SC945(P)(Q)(R)(K)	1
6-TR3	ET453611	Transistor 2SC1096(L) (K) (Z Type)	1
6-TR4	ET517994	Transistor 2SC945(P)(Q)(R)(K)	1
6-TR5	ET539122	Transistor 2SA733(P) (Q) (R)	1
6-D1 to 8	ED224526	Silicon Diode 10D1	8
6-D9, 10	ED539976	Zener Diode WZ-130	2
6-D11 to 14	ED224526	Silicon Diode 10D1	4
6-FR1	ER565828	Fuse/R. FRN1/4 10(K)700MA	1
6-3	AA545117	Heat-sink Plate	1
6-4	ZS447772	Tapping Screw #2 3x6 (BR)	1
6-5	EJ539662	Wrapping Post 1x17	19
<b>Capacitor, Vertical Type</b>			
6-C1, 2	EC403468	Elect. 330 $\mu$ F 50WV	2
6-C3, 4	EC321221	Elect. 100 $\mu$ F 50WV	2
6-C5	EC331817	Elect. 470 $\mu$ F 25WV	1
6-C6, 7	EC220127	Elect. 100 $\mu$ F 16WV	2
6-C8, 9	EC557627	Ceramic DB203YZ 0.01 $\mu$ F(Z) 50WV	2
6-C10	EC551160	Ceramic NB821YZ 0.01 $\mu$ F(Z) 1.4k $\mu$ WV	1
<b>Resistor, Stopper Type</b>			
6-R1	ER212883	Carbon RD1/4 4.7k(J)	1
6-R2	ER362441	Carbon RD1/4 1.8k(J)	1
6-R3	ER349828	Carbon RD1/4 20k(J)	1
6-R4	ER306887	Carbon RD1/4 15k(J)	1
6-R5	ER343135	Carbon RD1/4 1.6k(J)	1
6-R6	ER536984	Carbon RD1/2 4.7(J) (Insu. Type)	1
6-R6	ER554681	Carbon RD1/2 2.2(J) (Insu. Type)	1
6-R7	ER536984	Carbon RD1/2 4.7(J) (Insu. Type)	1
6-R8, 9	ER336442	Carbon RD1/4 10k(J)	2
6-R10	ER212264	Carbon RD1/4 22k(J)	1
6-R11	ER306887	Carbon RD1/4 15k(J)	1
6-R12	ER212264	Carbon RD1/4 22k(J)	1
6-R13	ER346601	Carbon RD1/4 47k(J)	1

When ordering parts, please describe Parts Number, Serial Number, and Model Number in detail.

**FIG. 7 PHOTO OF RECTIFIER  
P.C. BOARD (1) (98-5010) BLOCK**

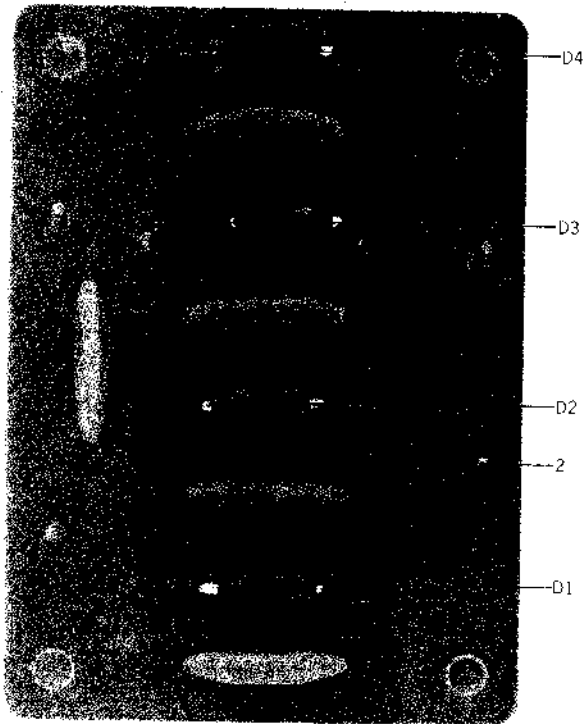

**FIG. 8 PHOTO OF RECTIFIER  
P.C. BOARD (2) (98-5011) BLOCK**

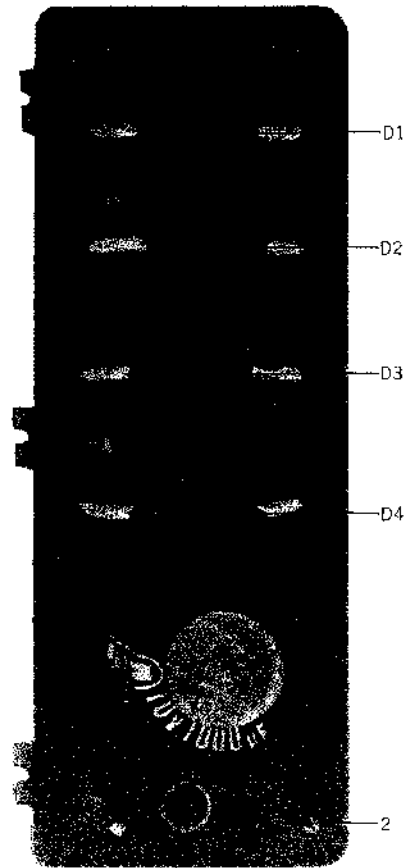

**RECTIFIER P.C. BOARD (1)  
(98-5010) BLOCK**

Symbol No.	Parts No.	Description	Q'ty
7-1x	BA560676	Rectifier P.C. Board (1) Comp. (98-5010)	1
7-D1 to 4	ED558033	Silicon Diode HIFI 400V 3A (Special)	4
7-2	EJ539662	Wrapping Post 1x17	4
7-C1 to 5	EC551160	Ceramic/C. NB821YZ 0.01 $\mu$ F(Z) 1.4kV	5

**RECTIFIER P.C. BOARD (2)  
(98-5011) BLOCK**

Symbol No.	Parts No.	Description	Q'ty
8-1x	BA560687	Rectifier P.C. Board (2) Comp. (98-5011)	1
8-D1 to 4	ED558033	Silicon Diode HIFI 400V 3A (Special)	4
8-2	EJ539662	Wrapping Post 1x17	4
8-C1	EC220410	Elect./C. 1000 $\mu$ F 10WV (Vert. Type)	1

When ordering parts, please describe Parts Number, Serial Number, and Model Number in detail.

FIG. 9 PHOTO OF TONE CONTROL P.C. BOARD (98-5007) BLOCK

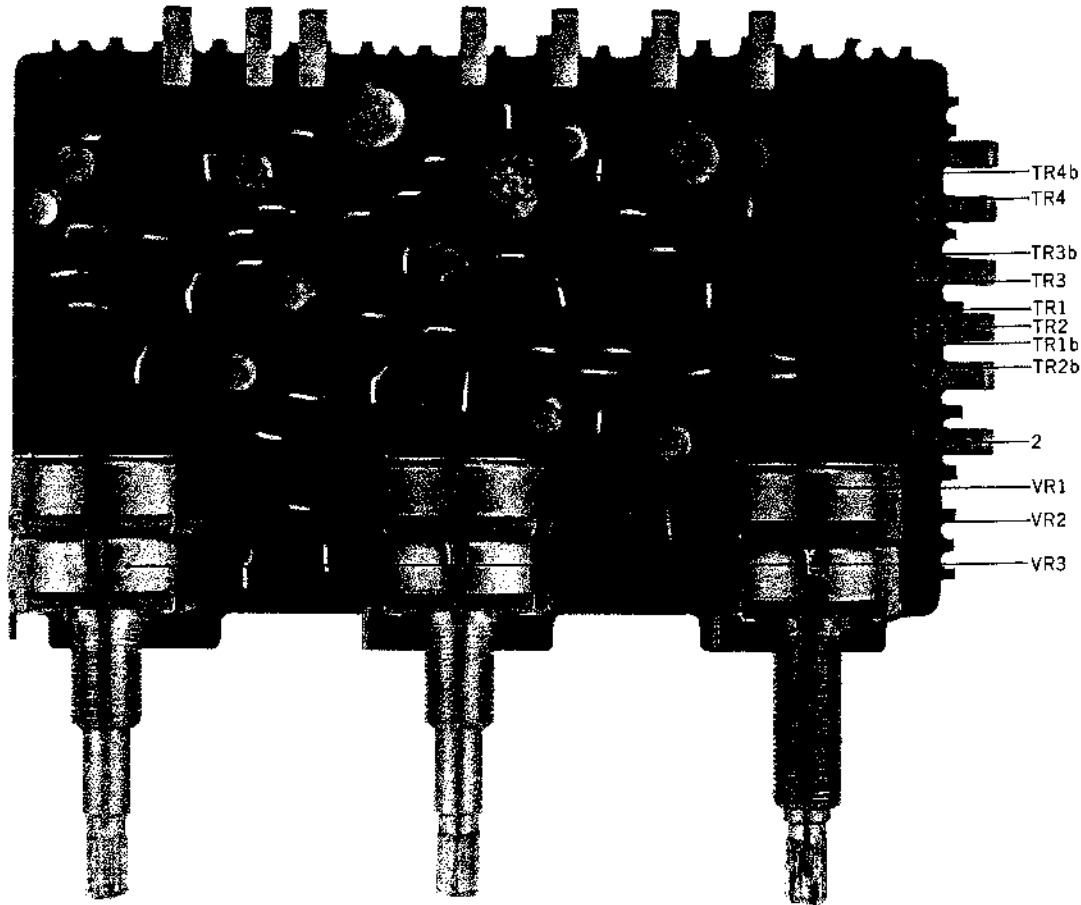

**TONE CONTROL P.C. BOARD  
(98-5007) BLOCK**

Symbol No.	Parts No.	Description	Q'ty	Symbol No.	Parts No.	Description	Q'ty
9-1x	BA560496	Tone Control P.C. Board Comp. (98-5007)	1	<b>Resistor, Stopper Type</b>			
9-TR1	ET539987	Transistor 2SC1312 (F) (G)	2	9-R1	ER211465	Carbon RD1/4 1k(J)	2
9-TR2 to 4	ET539987	Transistor 2SC1312 (F) (G)	6	9-R2	ER211757	Carbon RD1/4 100k(J)	2
9-VR1	EV557921	Co-axial 2-throw Vol. (w/click) V24L5GPHN 1Z 250kΩx2	1	9-R3	ER336442	Carbon RD1/4 10k(J)	2
9-VR2, 3	EV555941	Co-axial 2-throw Vol. (w/click) V24L5GPHN 1 kB 100kΩx2	2	9-R4	ER430042	Carbon RD1/4 2.4k(J)	2
9-2	EJ539673	Wrapping Terminal T5290	13	9-R5	ER352045	Carbon RD1/4 3.9k(J)	2
9-3x	EJ557932	Wrapping Terminal T5303	13	9-R6	ER213467	Carbon RD1/4 820(J)	2
<b>Capacitor, Vertical Type</b>				9-R7	ER336442	Carbon RD1/4 10k(J)	2
9-C1	EC313108	Elect. 1μF 50WV	2	9-R8	ER435303	Carbon RD1/4 5.1k(J)	2
9-C2	EC346735	Elect. 47μF 50WV	2	9-R9	ER211757	Carbon RD1/4 100k(J)	2
9-C3	EC313108	Elect. 1μF 50WV	2	9-R10	ER336442	Carbon RD1/4 10k(J)	2
9-C4	EC379214	Mylar 0.047μF(J) 50WV	2	9-R11	ER212883	Carbon RD1/4 4.7k(J)	2
9-C5	EC424708	Mylar 0.0018μF(J) 50WV	2	9-R12	ER211757	Carbon RD1/4 100k(J)	2
9-C6	EC379214	Mylar 0.047μF(J) 50WV	2	9-R13	ER336442	Carbon RD1/4 10k(J)	2
9-C7, 8	EC220994	Elect. 10μF 25WV	4	9-R14	ER211667	Carbon RD1/4 100(J)	2
9-C9	EC313108	Elect. 1μF 50WV	2	9-R15	ER211465	Carbon RD1/4 1k(J)	2
9-C10	EC346735	Elect. 47μF 50WV	1	9-R16	ER211757	Carbon RD1/4 100k(J)	2
				9-R17	ER357535	Carbon RD1/4 39k(J)	2
				9-R18	ER361620	Carbon RD1/4 300(J)	2
				9-R19	ER380755	Carbon RD1/4 6.2k(J)	2
				9-R20	ER406912	Carbon RD1/4 240(J)	2
				9-R21	ER211465	Carbon RD1/4 1k(J)	2
				9-R22	ER211667	Carbon RD1/4 100(J)	1

When ordering parts, please describe Parts Number, Serial Number, and Model Number in detail.

FIG. 10 PHOTO OF VOL. P.C. BOARD (98-5006) BLOCK

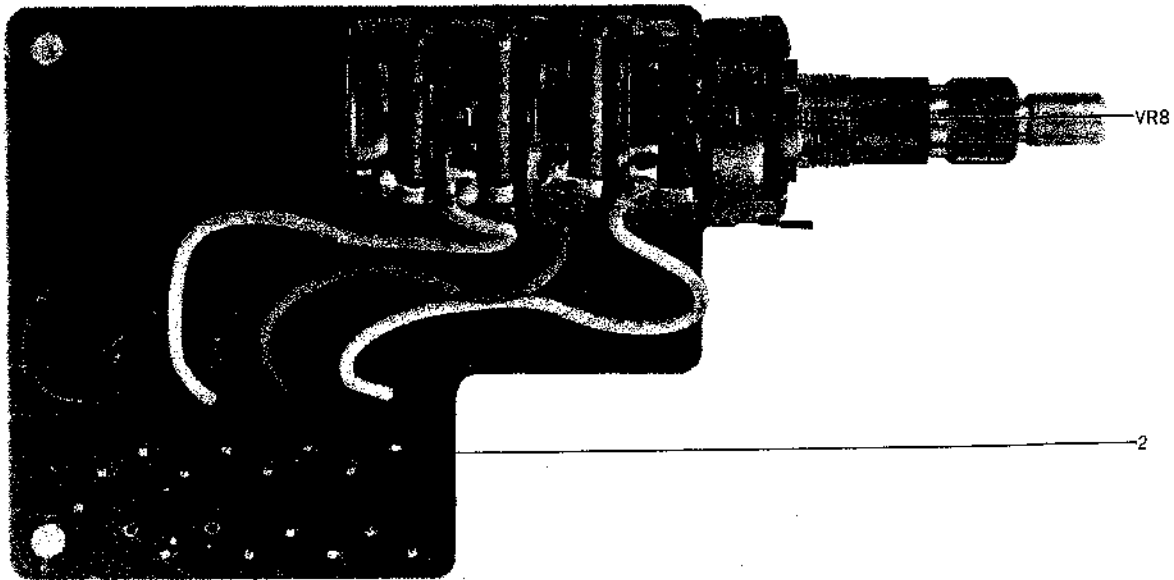

**VOL. P.C. BOARD (98-5006) BLOCK**

Symbol No.	Parts No.	Description	Q'ty
10-1x	BA562206	Vol. P.C. Board Comp. (98-5006)	1
10-VR8	EV557842	Co-axial 4-throw Vol. (w/preset) V24L5DPHN 2BL 250kx4	1
10-2	EJ539662	Wrapping Post 1x17	14
10-R1, 2	ER346994	Carbon/R. RD1/4 18k(J) (Stop. Type)	2

When ordering parts, please describe Parts Number, Serial Number, and Model Number in detail.

FIG. 11 PHOTO OF REMOTE P.C. BOARD (97-5003) BLOCK

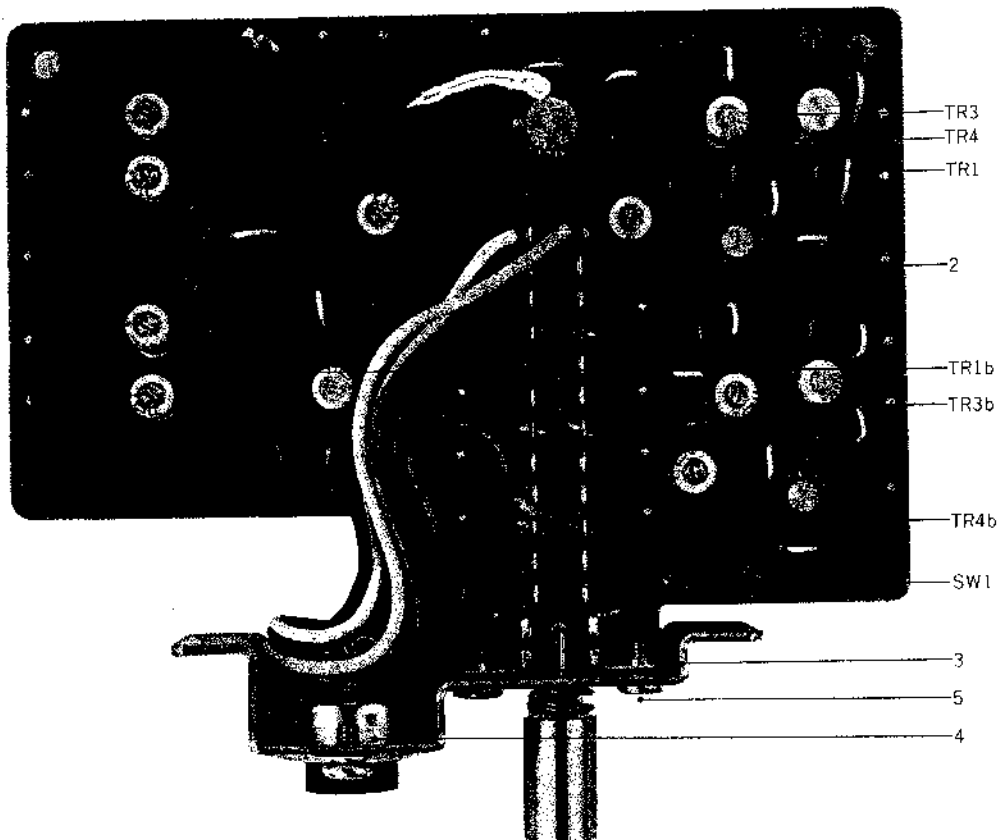

REMOTE P.C. BOARD (97-5003) BLOCK

Symbol No.	Parts No.	Description	Q'ty	Symbol No.	Parts No.	Description	Q'ty
11-1x	BA562217	Remote P.C. Board Comp. (97-5003)	1			<b>Resistor, Stopper Type</b>	
11-TR1 to 3	ET539987	Transistor 2SC1312 (F) (G)	6	11-R1	ER380711	Carbon RD1/4 220k(J)	2
11-SW1	ES591107	Push SW, 1FT-0001 AF-1320	1	11-R2	ER211757	Carbon RD1/4 100k(J)	2
11-2	EJ539662	Wrapping Post 1x17	23	11-R3, 4	ER336442	Carbon RD1/4 10k(J)	4
11-3	AZ545534	Switch Mt. Angle	1	11-R5	ER211465	Carbon RD1/4 1k(J)	2
11-4	EJ557910	Socket CS289	1	11-R6	ER350100	Carbon RD1/4 68k(J)	2
11-5	ZS371856	ISO Screw, binding head 3x5	4	11-R7	ER361528	Carbon RD1/4 56k(J)	2
		<b>Capacitor, Vertical Type</b>		11-R8	ER392850	Carbon RD1/4 390k(J)	2
11-C1	EC479621	Elect. 1 $\mu$ F 50WV NL	2	11-R9	ER211858	Carbon RD1/4 12k(J)	2
11-C2	EC476324	VFM 30PF(J) 50WV	2	11-R10	ER357456	Carbon RD1/4 2.2k(J)	2
11-C3 to 6	EC479621	Elect. 1 $\mu$ F 50WV NL	8	11-R11	ER343078	Carbon RD1/4 2.7k(J)	2
11-C7	EC450066	Elect. 33 $\mu$ F 16WV	2	11-R12	ER211667	Carbon RD1/4 100(J)	2
11-C8	EC476324	VFM 30PF(J) 50WV	2	11-R13	ER380711	Carbon RD1/4 220k(J)	2
11-C9	EC479621	Elect. 1 $\mu$ F 50WV NL	2	11-R14	ER211757	Carbon RD1/4 100k(J)	2
11-C10	EC346735	Elect. 47 $\mu$ F 50WV	2	11-R15	ER304290	Carbon RD1/4 10(J)	2
				11-R16	ER336442	Carbon RD1/4 10k(J)	2
				11-R17	ER363644	Carbon RD1/4 560(J)	1

When ordering parts, please describe Parts Number, Serial Number, and Model Number in detail.

FIG. 12 PHOTO OF FILTER P.C. BOARD (97-5005) BLOCK

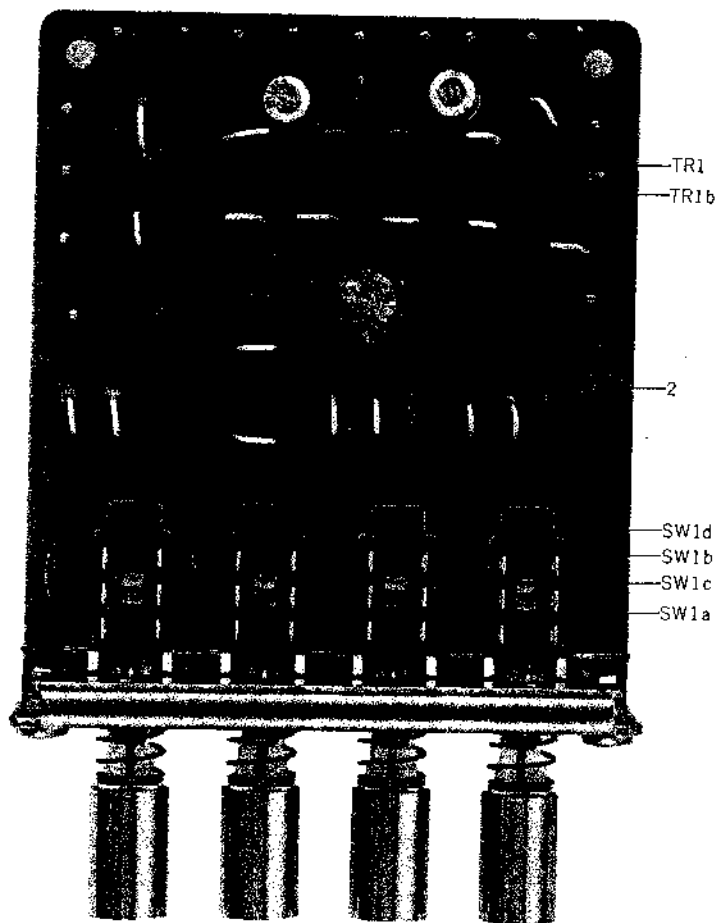

**FILTER P.C. BOARD (97-5005) BLOCK**

Symbol No.	Parts No.	Description	Q'ty
12-1x	BA562184	Filter P.C. Board Comp. (97-5005)	1
12-TR1	ET539987	Transistor 2SC1312 (F) (G)	2
12-SW1	ES591153	Push SW. 4FT-0001 DF-2020	1
12-2	EJ539662	Wrapping Post 1x17	16
<b>Capacitor, Vertical Type</b>			
12-C1	EC368335	Mylar 0.022 $\mu$ F(J) 50WV	2
12-C2	EC389237	VFM 200PF(J) 50WV	2
12-C3	EC368357	Mylar 0.056 $\mu$ F(J) 50WV	2
12-C4	EC411827	Mylar 0.0082 $\mu$ F(J) 50WV	2
12-C5	EC522516	Tantalum 1 $\mu$ F(M) 25WV (DTS Type)	2
12-C6	EC479621	Elect. 1 $\mu$ F 50WV NL	2
12-C7	EC377212	VFM 47PF(J) 50WV	2
12-C8	EC455354	Elect. 100 $\mu$ F 35WV	1
<b>Resistor, Stopper Type</b>			
12-R1	ER346994	Carbon RD1/4 18k(J)	2
12-R2	ER357570	Carbon RD1/4 150k(J)	2
12-R3	ER350100	Carbon RD1/4 68k(J)	2
12-R4	ER346544	Carbon RD1/4 3k(J)	2
12-R5	ER429996	Carbon RD1/4 470k(J)	2
12-R6	ER380711	Carbon RD1/4 220k(J)	2
12-R7	ER211757	Carbon RD1/4 100k(J)	2
12-R8	ER304290	Carbon RD1/4 10(J)	2
12-R9	ER336442	Carbon RD1/4 10k(J)	2
12-R10	ER211757	Carbon RD1/4 100k(J)	2
12-R11	ER211667	Carbon RD1/4 100(J)	1

When ordering parts, please describe Parts Number, Serial Number, and Model Number in detail.



FIG. 13 PHOTO OF MIC, DUB P.C. BOARD (97-5006) BLOCK

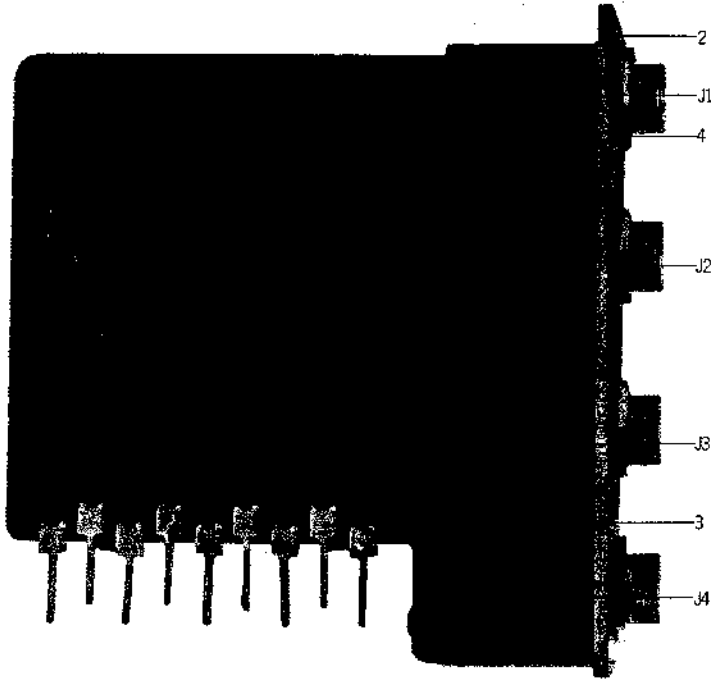

MIC, DUB P.C. BOARD (97-5006) BLOCK

Symbol No.	Parts No.	Description	Q'ty
13-1x	BA 562241	Mic, Dub P.C. Board Comp. (97-5006)	1
13-J1, 2	EJ437310	Mic. Jack 2PMJ1P	2
13-J3, 4	EJ437321	Jack, 3P Molded 3PMJ1P	2
13-2	AZ545567	Mic, Dub Mt. Plate	1
13-3	EJ550012	Wrapping Terminal T5280	9
13-4	ZW270191	E Jack Nut	4

When ordering parts, please describe Parts Number, Serial Number, and Model Number in detail.

FIG. 14 PHOTO OF HP P.C. BOARD (98-5012) BLOCK

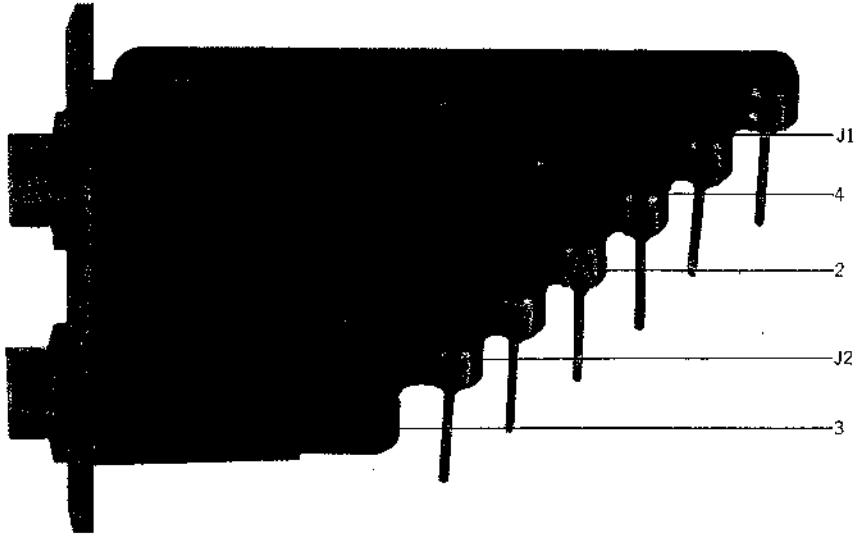

**HP P.C. BOARD (98-5012) BLOCK**

Symbol No.	Parts No.	Description	Q'ty
14-1x	BA560531	HP P.C. Board Comp. (98-5012)	1
14-J1, 2	EJ437321	Jack, 3P Molded 3PMJ1P	2
14-2	EJ550012	Wrapping Terminal T5280	6
14-3	AZ544836	Phone Jack Mt. Plate	1
14-4	ZW270191	E Jack Nut	2
14-R1 to 4	ERS59034	Metal Oxide Film/R. 2W330Ω(K)	4

When ordering parts, please describe Parts Number, Serial Number, and Model Number in detail.

FIG. 15 PHOTO OF METER P.C. BOARD (97-5001) BLOCK

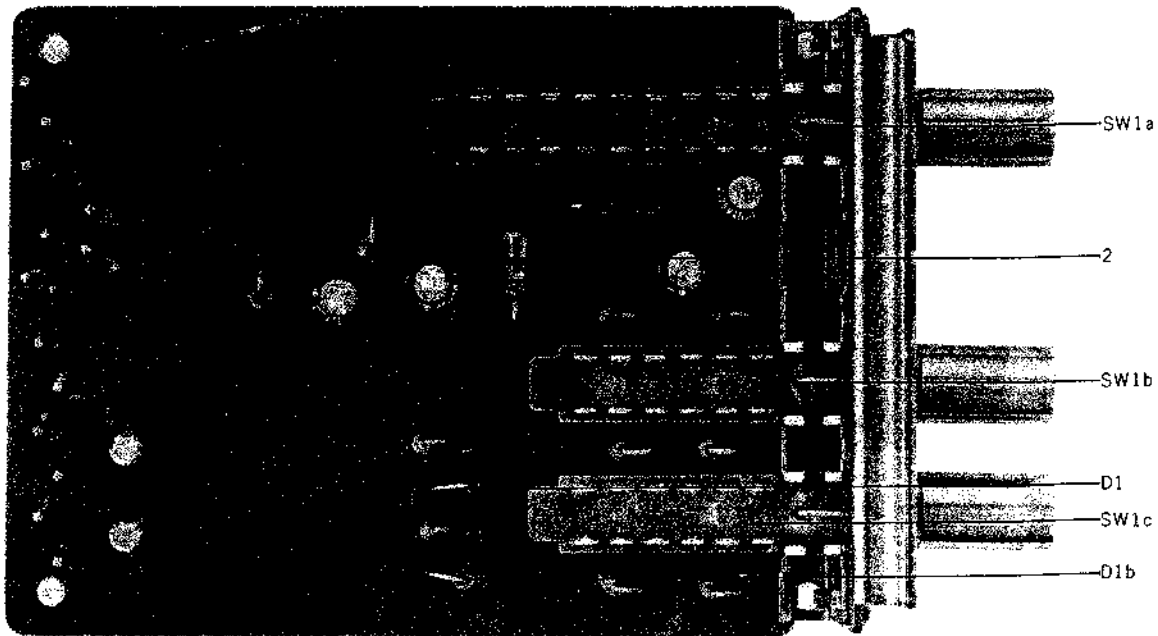

**METER P.C. BOARD (97-5001) BLOCK**

Symbol No.	Parts No.	Description	Q'ty
15-1x	BA562228	Meter P.C. Board Comp. (97-5001)	1
15-D1	ED219464	Germanium Diode 1N34A	2
15-SW1	ES561960	Push SW. 3FS-14U-503	1
15-2	EJ539662	Wrapping Post 1x17	13
<b>Capacitor, Vertical Type</b>			
15-C1	EC523282	Solid Aluminum 0.1 $\mu$ F(M) 25WV	2
15-C2, 3	EC220994	Elect. 10 $\mu$ F 25WV	4
<b>Resistor, Stopper Type</b>			
15-R1	ER349828	Carbon RD1/4 20k(J)	2
15-R2	ER357535	Carbon RD1/4 39k(J)	2
15-R3	ER212883	Carbon RD1/4 4.7k(J)	2
15-R4	ER213467	Carbon RD1/4 820(J)	2
15-R5, 6	ER557796	Carbon RD1/2 470(K)	4

When ordering parts, please describe Parts Number, Serial Number, and Model Number in detail.

FIG. 16 PHOTO OF TAPE P.C. BOARD (97-5004) BLOCK

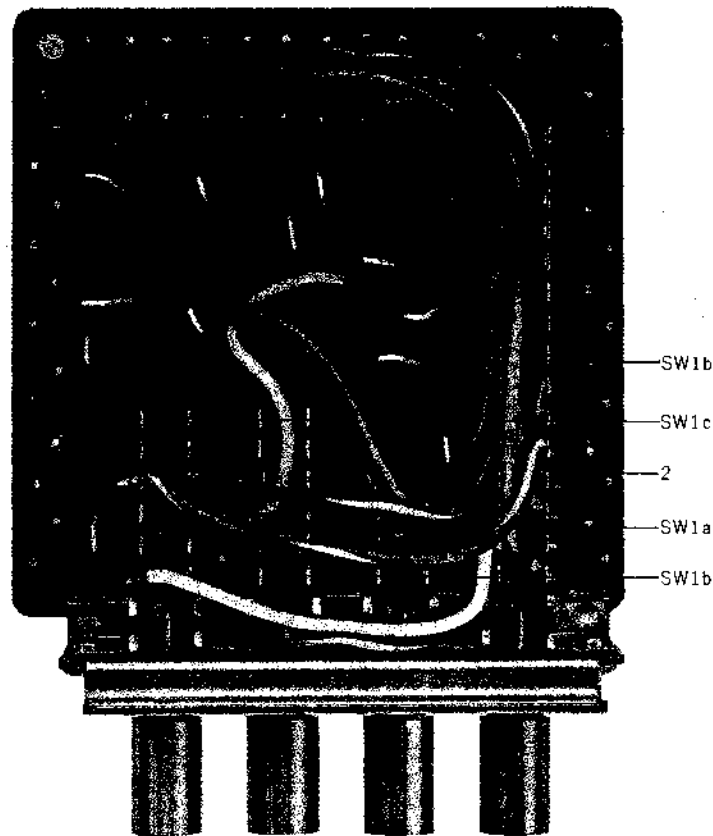

**TAPE P.C. BOARD (97-5004) BLOCK.**

Symbol No.	Parts No.	Description	Q'ty
16-1x	BA562230	Tape P.C. Board Comp. (97-5004)	1
16-SW1	ES591142	Push SW. 4FT-0002 DF-2020	1
16-2	EJ539662	Wrapping Post 1x17	50
16-C1 to 10	EC557616	Ceramic/C. UFD06B 390PF(K) 50WV	10
<b>Resistor, Stopper Type</b>			
16-R1 to 10	ER371946	Carbon RD1/4 2k(J)	10
16-R11, 12	ER336442	Carbon RD1/4 10k(J)	2

When ordering parts, please describe Parts Number, Serial Number, and Model Number in detail.

**FIG. 17 PHOTO OF BALANCE  
P.C. BOARD (97-5002) BLOCK**

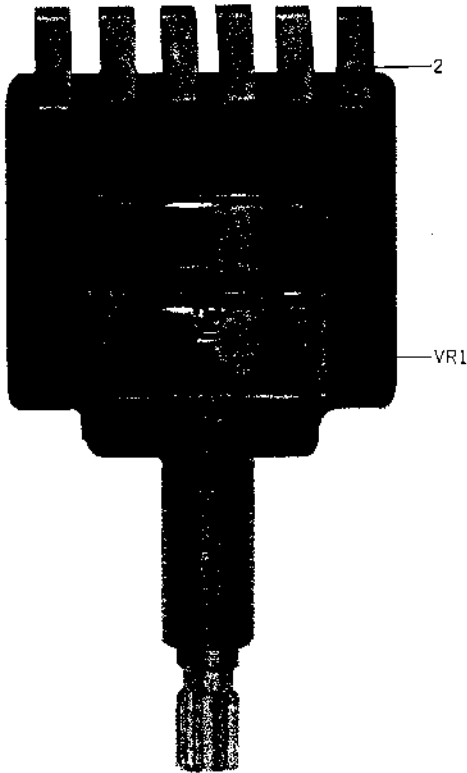

**FIG. 18 PHOTO OF LAMP.  
P.C. BOARD (97-5008) BLOCK**

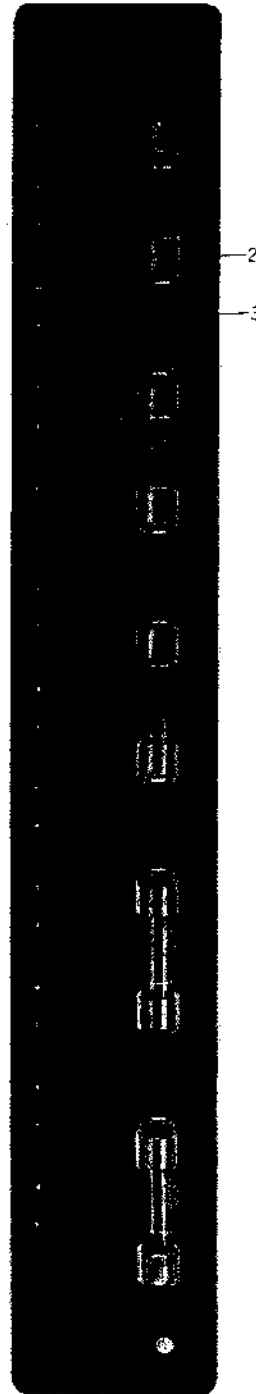

**BALANCE P.C. BOARD (97-5002) BLOCK**

Symbol No.	Parts No.	Description	Q'ty
17-1x	BA562195	Balance P.C. Board Comp. (97-5002)	1
17-VR1	EV557921	Co-axial 2-throw Vol. (w/click)	
		V24L5GPHN 1Z 250kΩx2	1
17-2	EJ539673	Wrapping Terminal T5290	6

**LAMP P.C. BOARD (97-5008) BLOCK**

Symbol No.	Parts No.	Description	Q'ty
18-1x	BA562274	Lamp P.C. Board Comp. (97-5008)	1
18-2	EJ514822	Fuse Holder, P.C. Board S-N5051	10
18-3	EJ539662	Wrapping Post 1x17	17

When ordering parts, please describe Parts Number, Serial Number, and Model Number in detail.

FIG. 19 PHOTO OF FRONT CHASSIS BLOCK

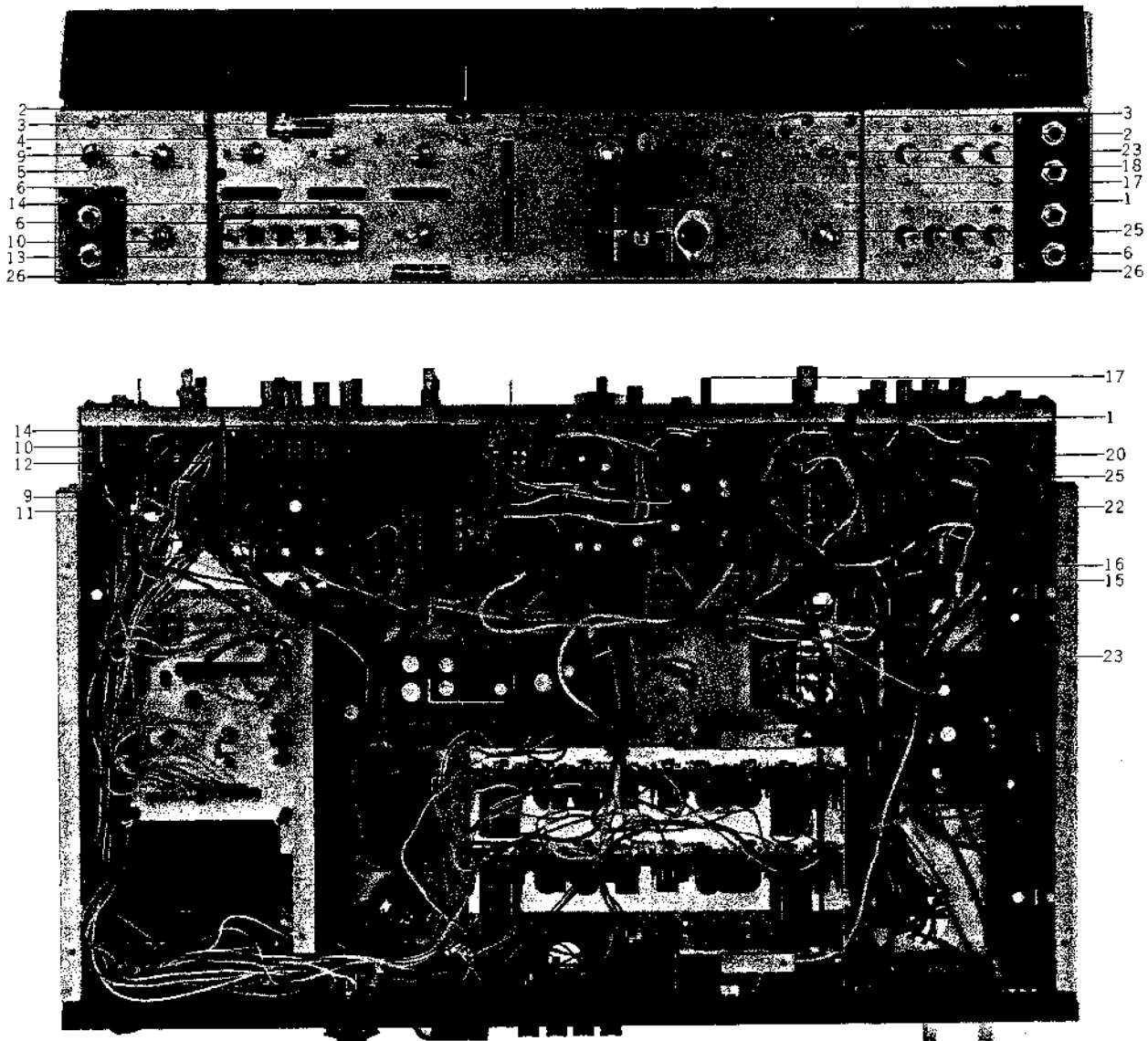

FRONT CHASSIS BLOCK

Ref. No.	Parts No.	Description	Schematic No.	Q'ty	Ref. No.	Parts No.	Description	Schematic No.	Q'ty
19-1	AZ545782	Front Chassis, w/chassis L,R	97-5016	1	19-14	HV557741	4-throw Slide Vol. (center click) VJ458G4RN		
19-2	ZS530684	Roller Screw B (L=13)	91-5010	3					
19-3	MR530662	Roller B (D=10)	91-5009	3					
19-4	MR530651	Roller A (D=14)	91-5008	1	19-15	EJ557728	Wire Clip 0128	36-34-1	1
19-5	ES468448	Lever SW. SDD4LFJO (LPS60122FJOO) (Power)	25-4-12	1	19-16	EJ514034	PC Support	2-7-19	1
19-6	ZS371856	ISO Screw, binding head 3x5		28	19-17	MS530752	Tuning Shaft	91-5018	1
19-7x	EC551160	Ceramic/C. NB821 YZ 0.01μF(Z)1.4 kWV	24-5-55	2	19-18	AA530741	Tuning Metal	91-5017	1
19-8x	EC565896	Ceramic/C. DP6600 YM 0.01μF(P)1.4 kWV	24-5-58	2	19-19x	ZW561993	Washer D6.1x10x1t		2
19-9	ES561914	Rotary SW. SR32N 3-8-2 25KC	25-7-34	1	19-20	BF530763	Flywheel	91-5019	1
19-10	ES561925	Rotary SW. SR32N 2-8-4 25KC	25-7-32	1	19-21x	ZS462936	ISO Set Screw, hexagon socket 3x5(cup/p.)		1
19-11	MZ229138	Wire Bundle Holder N-108	2-35-1	16	19-22	AZ545545	Selector SW. Mt. Angle	97-5020	1
19-12	AZ545512	Rotary SW. Shield Plate	97-5017	1	19-23	ES561936	Rotary SW. Y7-1-7-5 (Selector)	25-7-37	1
19-13	AZ545523	Push SW. Mt. Plate	97-5018	3	19-24x	ER427961	Carbon/R. RD1/4 43kΩ(J) (Insu. Type)	35-9-5	2
					19-25	ES557763	Rotary SW. SR26N 5-15-5 35KH	25-6-63	1
					19-26	ZS447772	Tapping Screw #2 3x6 (BR)		8
					19-27x	EZ585134	Mic. Dub Spacer	97-5062	1

When ordering parts, please describe Parts Number, Serial Number, and Model Number in detail.

FIG. 20 PHOTO OF SCALE MT. PLATE/REAR PANEL BLOCK

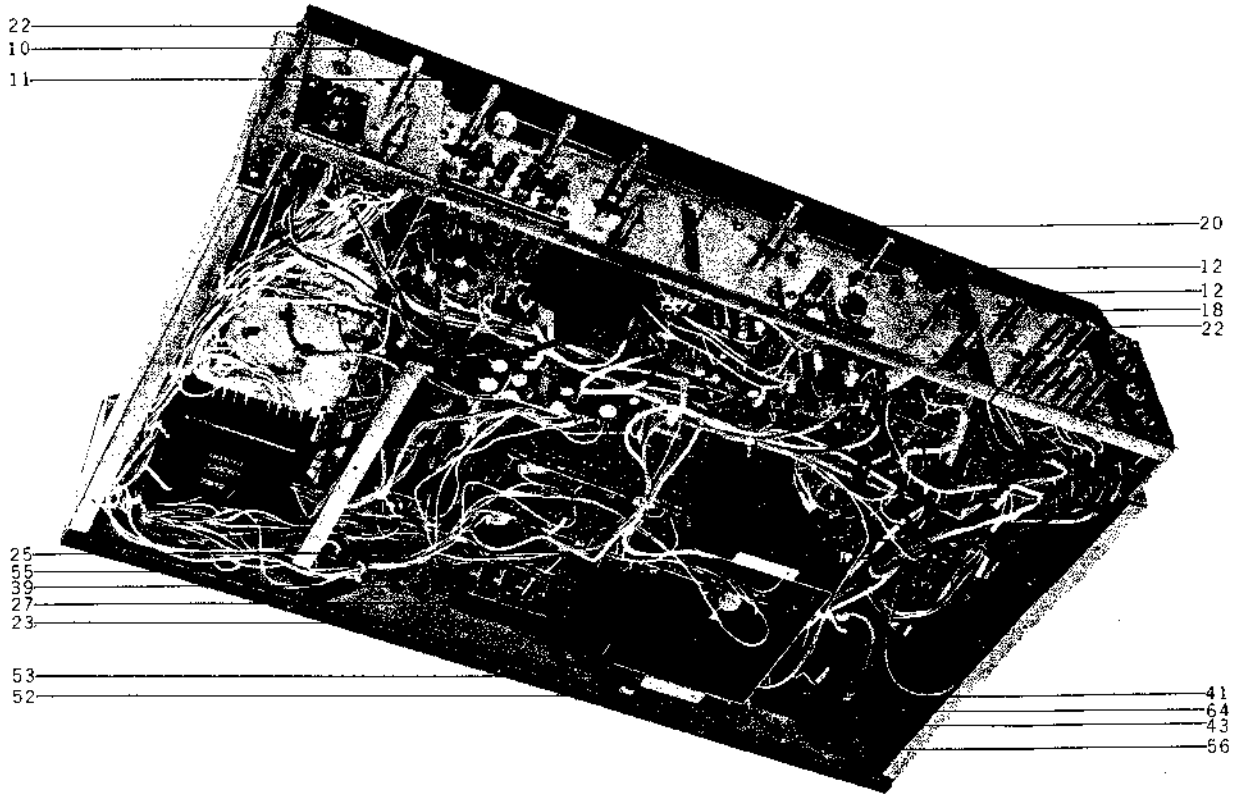
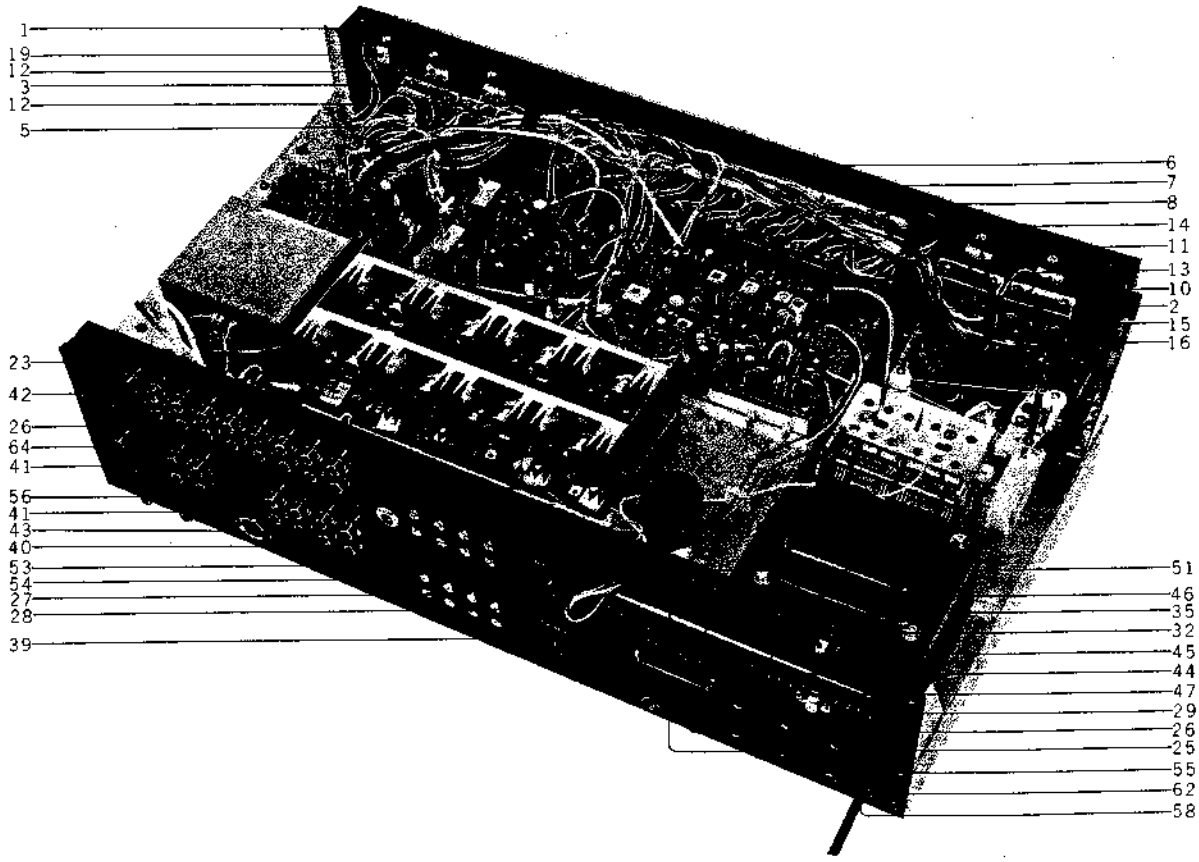

## SCALE MT. PLATE/REAR PANEL BLOCK

Ref. No.	Parts No.	Description	Schematic No.	Q'ty	Ref. No.	Parts No.	Description	Schematic No.	Q'ty
<b>SCALE MT. PLATE BLOCK</b>					20-61x	EW524845	AC Cord (JPN) 2.5M	26-3-31	1
20-1	AZ545760	Scale Plate Mt. Chassis	97-5023	1	20-62	EZ382263	Strain Relief SR-4K-4	2-7-12	1
20-2	AA530785	Lamp Case	91-5021	1	20-63x	EZ246936	Strain Relief SR-6W-1 (WG, 3 core)	2-7-8	1
20-3	ZS447772	Tapping Screw #2 3x6 (BR)		24	20-64	EJ354936	1P Pin-Jack	31-1-32	1
20-4x	EL539684	Fuse Type Lamp 8V 0.3A	28-2-27	5					
20-5	MZ259233	Wire Band C	3A-745	2					
20-6	AA545668	Lamp Holder	97-5025	1					
20-7	AZ545670	Lamp Holder Case	97-5026	1					
20-8	EL550045	Cord Lamp 8V 50 mA							
		(ST. Ind.)	28-2-30	12					
20-9x	SM531336	Illumination Plate, Pointer	91-5065	1					
20-10	EM551248	Signal Meter KL-218L-25	46-1-71	1					
20-11	EM551250	Tuning Meter KL-218L-27	46-1-70	1					
20-12	EM539706	Level Meter KL-218L-28	46-1-69	2					
20-13	AA533384	Meter Mt. Angle	94-5030	2					
20-14	ZS371856	ISO Screw, binding head 3x5		5					
20-15	AA530820	Meter Case	91-5025	4					
20-16	EJ367986	Fuse Holder 1P AC125V 5A	40-1-8	4					
20-17x	EL539684	Fuse Type Lamp 8V 0.3A	28-2-27	4					
20-18	EM558044	Indicator (2-4CH)	28-2-31	1					
20-19	AA544926	Indicator Support	98-5045	1					
20-20	AA547446	Scale Plate B	97-5024	1					
20-21x	AA547435	Scale Plate A(J)	97-5024	1					
20-22	EJ556143	Canoe Clip (Large)	2-7-35	2					
<b>REAR PANEL BLOCK</b>									
20-23	SP545758	Rear Panel A	97-5027	1					
20-24x	SP569621	Rear Panel B (CSA)	97-5027	1					
20-25	EJ233370	Socket (Volt. Selector)							
		S-18010	40-2-3	1					
20-26	ZS552611	ISO Screw, pan head 3x8 (Black)		6					
20-27	EJ539785	Consent, Speaker (2-throw)	31-1-96	2					
20-28	ZS570385	ISO Taptight Screw, pan head 3x8 (Black)		16					
20-29	AA510625	Antenna Terminal Plate 5P	32-1-29	1					
20-30x	ZW348107	ISO Nut M3		5					
20-31x	BT444137	Balun Trans. 75Ω-300Ω	23-1-129	1					
20-32	ES320016	Slide SW. MFS-201NB	25-3-21	1					
20-33x	ER212016	Carbon/R. RD1/4 150Ω(J) (Stop. Type)	35-10-1	1					
20-34x	ER551621	Carbon/R. RD1/2 150Ω(J) (Insu. Type)	35-9-15	1					
20-35	ZW562015	ISO Screw, binding head 2x4		2					
20-36x	ZW273802	Toothed Lock Washer M3		3					
20-37x	ZW273778	Earth Lug M3		1					
20-38x	ZS553904	ISO Screw, binding head 3x8		1					
20-39	EJ539796	Fuse Holder 2P	40-1-29	2					
20-40	ZS447761	Tapping Screw #2 3x6 (BR) (Black)		8					
20-41	EJ539763	Wrapping Pin Jack B 4P T5346(B)	31-1-106	6					
20-42	EJ551340	Wrapping Pin Jack B 6P T5347(B)	31-1-102	1					
20-43	EJ299305	Jack, 5P Din	31-1-1	1					
20-44	AA530910	Antenna Channel	91-5029	1					
20-45	AA557886	Bar Antenna (970)	55-1-16	1					
20-46	AA378268	Antenna Support	AA-5552	1					
20-47	ZS379451	ISO Screw, round head 4x50		1					
20-48x	ZW273914	Spring Washer M4		2					
20-49x	ZW556132	ISO Nut M4		1					
20-50x	ZW551373	Washer, D4.2x8x0.5t		2					
20-51	EZ382263	Strain Relief SR-4K-4	2-7-12	1					
20-52	AZ544950	Volume Retaining Parts	98-5049	1					
20-53	EV557897	Vol. V16L4N B1K	36-6-2	1					
20-54	ZS552622	ISO Screw, pan head 3x6 (Black)		2					
20-55	EJ378944	Socket, AC U/L S-I 9122	31-1-47	3					
20-56	EZ486257	Metal Terminal T-10	32-1-27	2					
20-57x	ER428567	Solid/R. RC1/2W 2.2M(K)	35-5-4	1					
20-58	EW540112	AC Cord (CUL) 2.5M	26-3-19	1					
20-59x	EW486797	Power Supply Cord VDE (WG)	26-3-26	1					
20-60x	EW315448	Australia Cord (3 core)	26-3-11	1					

When ordering parts, please describe Parts Number, Serial Number, and Model Number in detail.



FIG. 21 PHOTO OF ASSEMBLY BLOCK

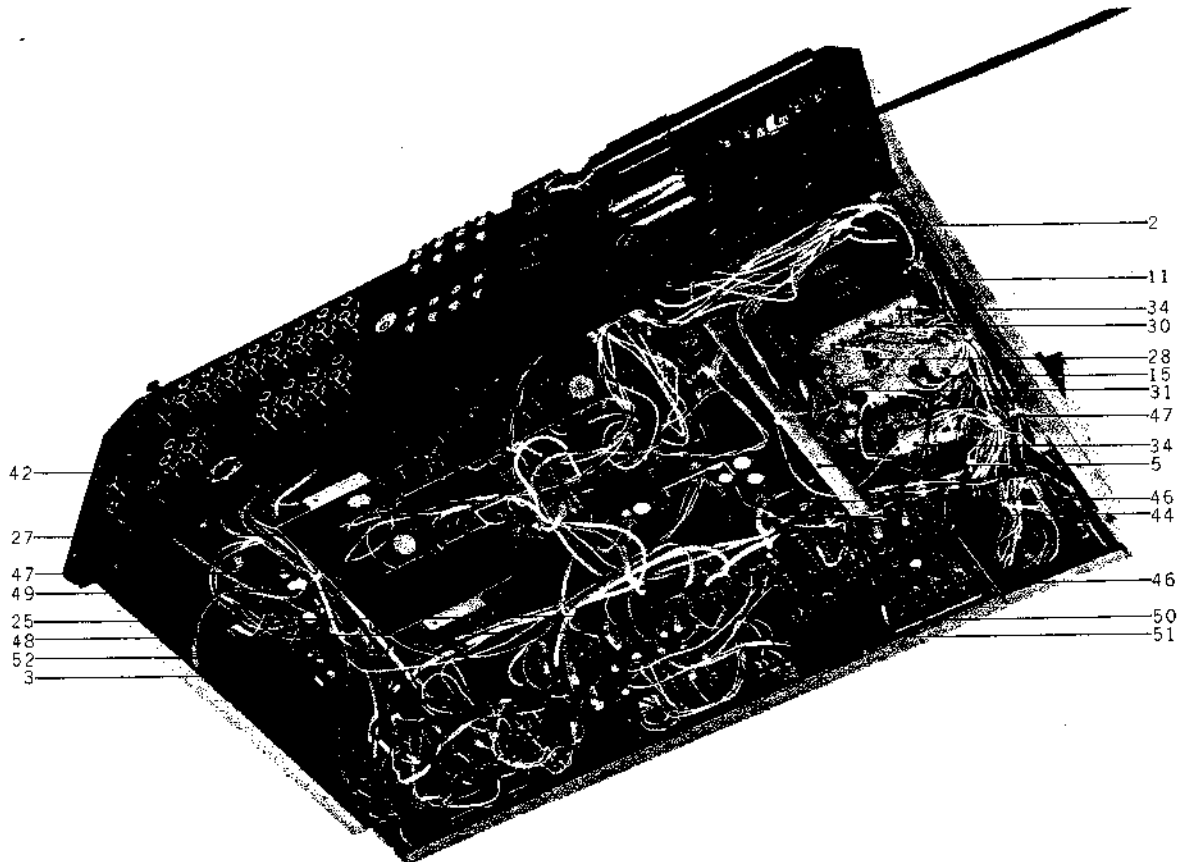
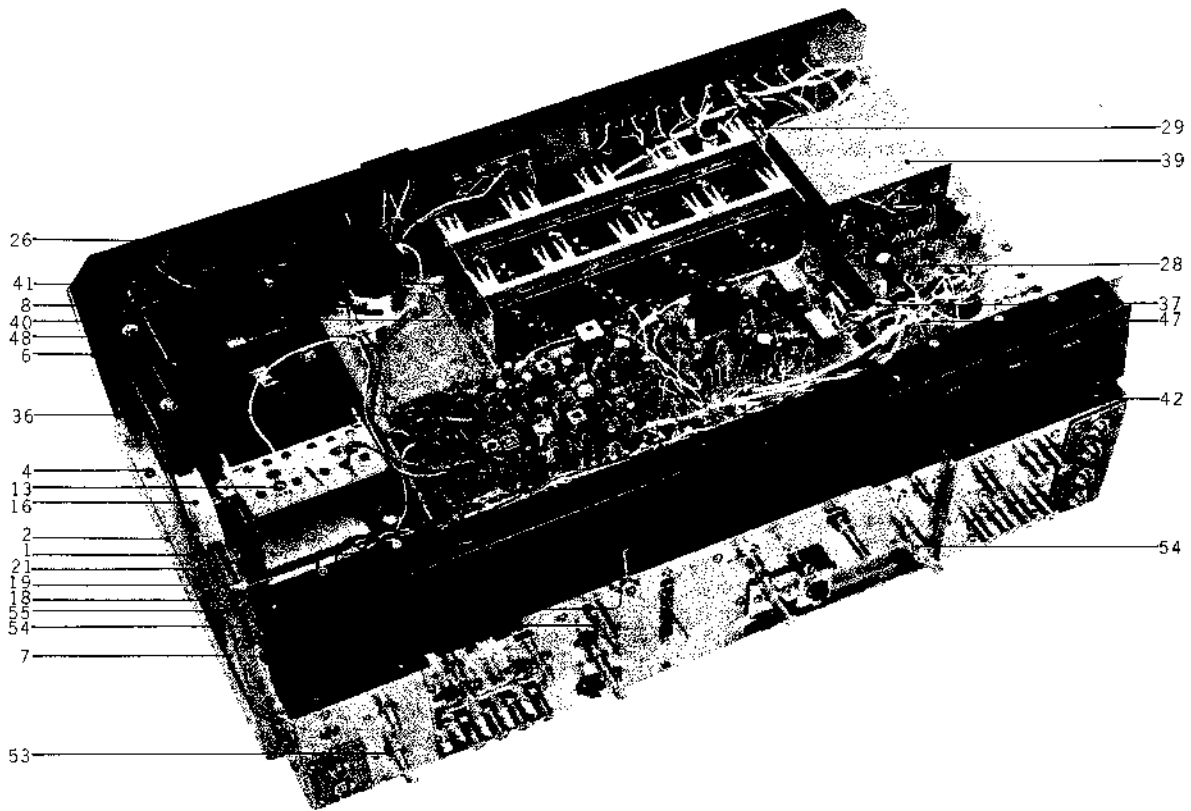

## ASSEMBLY BLOCK

Ref. No.	Parts No.	Description	Schematic No.	Qty
21-1	AZ545771	Main Chassis, w/sub chassis	97-5011	1
21-2	AZ545635	Side Plate L	97-5013	1
21-3	AZ545646	Side Plate R	97-5014	1
21-4	ZS447772	Tapping Screw #2 3x6 (BR)		80
21-5	AZ545657	Supporting Plate	97-5015	1
21-6	AZ545130	Supporting Plate A	98-5029	1
21-7	AZ545141	Supporting Plate B	98-5029	1
21-8	BT561903	Power Trans. AS-970T-1	38-4-255	1
21-9x	BT570464	Power Trans. AS-970T-2 (CSA)	38-4-271	1
21-10x	ZW273914	Spring Washer M4		4
21-11	ZW510660	ISO Nut M4		4
21-12x	ZW273881	Earth Lug M4		1
21-13	AF510300	Front End FL-315U19	57-2-19	1
21-14x	AF510298	Front End FL-315J17 (J)	57-2-18	1
21-15	ZS321298	ISO Screw, binding head 3x8		5
21-16	MR530706	Pulley	91-5012	1
21-17x	ZG549011	Tuning Spring	91-5094	1
21-18	AA532102	Roller Mt. Angle	94-5007	1
21-19	MR530651	Roller A (D=10)	91-5008	3
21-20x	MR530662	Roller B (D=14)	91-5009	2
21-21	ZW530673	Roller Screw A (L=9)	91-5010	3
21-22x	AZ545591	Roller Mt. Angle (Small)	97-5037	1
21-23x	ZS530684	Roller Screw B (L=13)	91-5010	1
21-24x	AZ547367	Chassis Reinforcement (Slide)	97-5049	1
21-25	AZ545578	Remote P.C. Board Support Angle	97-5030	1
21-26	EC557695	Elect./C. 3,300µF 80WV (Lug Type)	24-10-79	1
21-27	EJ551035	Wrapping Terminal 4P T5251	32-1-36	4
21-28	EJ539447	Earth Terminal 2P T-4460	32-1-32	3
21-29	EJ561982	Lug Plate 4P T-5247	33-5-8	1
21-30	ZS447805	Tapping Screw #2 3x12 (BR)		3
21-31	EJ254970	Lug Plate KP1L1	33-3-3	1
21-32x	ER452777	Carbon/R. RD1/4 160k(J) (Insu. Type)	35-9-5	2
21-33x	ER364994	Carbon/R. RD1/4 39k(J) (Insu. Type)	35-9-5	2
21-34	EJ550067	Lug Plate 4P T-5305	33-5-5	2
21-35x	EJ258025	Lug Plate KP2L1	33-3-4	1
21-36	AA530627	IF P.C. Board Mt. Plate	91-5005	2
21-37	EJ514034	PC Support	2-7-20	23
21-38x	ER489780	Carbon/R. RD1/4 300Ω(J) (Insu. Type)	35-9-5	1
21-39	AZ547356	SQ Shield	97-5050	1
21-40	AZ545163	Heat-sink Retaining Plate	98-5021	2
21-41	ZS371856	ISO Screw, binding head 3x5		9
21-42	ZS447761	Tapping Screw #2 3x6 (BR) (Black)		14
21-43x	EZ545602	P.C. Board Support	97-5038	1
21-44	AZ545556	Vol. P.C. Board Support	97-5021	1
21-45x	AZ545613	Filter P.C. Board Support	97-5039	1
21-46	EJ557717	Wire Clip 0017	2-7-26	3
21-47	EJ551057	Wire Clip 220-JD481010-0021	2-7-27	7
21-48	EJ557728	Wire Clip 0128	2-7-19	2
21-49	AZ545681	Main Amp. Shield	97-5031	1
21-50	AA545580	Balance Insulator Plate	97-5033	1
21-51	EJ556143	Canoe Clip (Large)	2-7-35	1
21-52	EJ553948	Wire Bundle Holder B-100	2-35-3	3
21-53	AA531360	Stop Collar 1 (L=2.5)	91-5074	1
21-54	AA531371	Stop Collar 2 (L=12.5)	91-5074	2
21-55	AA530954	Dial Pointer	91-5039	1
21-56x	ZS406416	Tapping Screw #2 3x8 countersunk		3
21-57x	ZS447840	Tapping Screw #2 3x8 (BR)		5

When ordering parts, please describe Parts Number, Serial Number, and Model Number in detail.

FIG. 22 PHOTO OF FINAL ASSEMBLY BLOCK

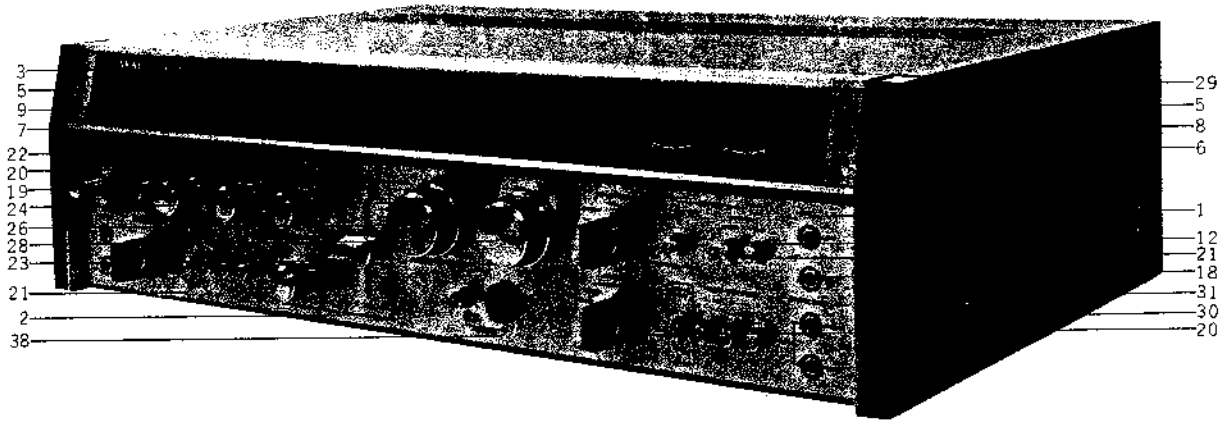

**FINAL ASSEMBLY BLOCK**

Ref. No.	Parts No.	Description	Schematic No.	Q'ty	Ref. No.	Parts No.	Description	Schematic No.	Q'ty
<b>FRONT PANEL BLOCK</b>									
22-1	SP545747	Front Panel	97-5028	1	22-28	SK531213	Tuning Knob	91-5050	1
22-2	SE546208	Slide Mask	98-5069	1	22-29	BC545725	Cabinet	97-5035	1
22-3	AZ531055	Front Plate 8	91-5044	1	22-30	ZW548010	Spot Facing Washer	MU-6028	4
22-4x	AA530976	Retaining Plate Cushion	91-5043	2	22-31	ZW552824	ISO Screw, binding head 4x18 (Black)		4
22-5	AA531145	Fitting 2	91-5045	2	22-32x	EF562691	Fuse 2.5A 250V	49-1-50	4
22-6	AA541517	Side Molding A (Right)	91-5082	1	22-33x	EF424811	Fuse ST-2 2.5A (CSA)	39-1-26	4
22-7	AA541528	Side Molding B (Left)	91-5082	1	22-34x	EF575234	Fuse 6A 250V	39-1-50	1
22-8	AA531156	Side Fitting A (Right)	91-5046	1	22-35x	EF563657	Fuse 3A 250V	39-1-50	1
22-9	AA531167	Side Fitting B (Left)	91-5046	1	22-36x	AA539537	Fuse Holder Cover 2P	2-34-78	2
22-10x	ZS447805	Tapping Screw #2 3x12 (BR)		6	22-37x	ZS379350	ISO Screw, pan head 3x6		2
22-11x	ZS447840	Tapping Screw #2 3x8 (BR)		2	22-38	AA545894	Remote Jack Cover	98-5062	1
22-12	AA545905	Push Button Bush	98-5061	12	22-39x	EA576112	Fuse P.C. Board A (CSA)	97-5057	1
<b>ASSEMBLY BLOCK</b>									
22-13x	AZ545736	Bottom Plate	97-5034	1	22-40x	AA569586	Fuse Angle A (CSA)	97-5058	1
22-14x	ZS447772	Tapping Screw #2 3x6 (BR)		11	22-41x	EF277424	Fuse ST-4 0.8A (CSA)	39-1-28	2
22-15x	SA377190	Rubber Foot, LM	LM-404	4	22-42x	EF459843	Fuse ST-2 5A (CSA)	39-1-26	1
22-16x	ZW419646	Washer (SPC) D4.5x9.8x0.5t		4	22-43x	EJ514822	Fuse Holder, P.C. Board S-N5051 (CSA)	40-1-28	16
22-17x	ZS463375	Tapping Screw #2 4x15 (Truss)		4	22-44x	EJ539662	Wrapping Post 1x17 (CSA)	32-1-48	16
22-18	EZ436217	Collar For Jack	MC-5006	6	22-45x	EA549448	Fuse P.C. Board (CSA)	92-5022	2
22-19	SK531314	Power knob	91-5060	1	22-46x	AA569610	Barrier (CSA)	97-5059	1
22-20	SK547964	Selector Knob	98-5080	4	22-47x	EJ550912	Speaker Plug ASP-1	42-1-64	3
22-21	SK531224	Push Button Knob	91-5051	12	22-48x	EJ552778	Short Pin Plug P-0107	42-1-65	2
22-22	SK531281	Single Knob	91-5057	4	22-49x	AA560092	FM Antenna AFM-1B (5003-03)	55-1-18	1
22-23	SK545027	Slide Knob	98-5055	1	22-50x	AA560081	FM Antenna AFM-1A (5003-04) (J)	55-1-18	1
22-24	SK531347	Volume Knob Ring	91-5071	1	22-51x	EF562544	Fuse 6A 125V	39-1-47	1
22-25x	ZW493312	Washer (Nylon) D6.2x10x1t		1	22-52x	EF562680	Fuse 5A 125V	39-1-47	1
22-26	SK531358	Volume Knob	91-5073	1					
22-27x	ZS446422	ISO Set Screw, hexagon socket 4x8(cup/p.)		2					

When ordering parts, please describe Parts Number, Serial Number, and Model Number in detail.

# INDEX

Parts No.	Ref. No. & Symbol No.	Parts No.	Ref. No. & Symbol No.	Parts No.	Ref. No. & Symbol No.	Parts No.	Ref. No. & Symbol No.	Parts No.	Ref. No. & Symbol No.
AA378268	20-46	BA570453	6-2x	EC380621	2-C20, 21	EJ254970	21-31	ER211667	1-R44, 45
AA510625	20-29	BA570903	4-1x	EC389237	4-C8	EJ255025	21-35x	ER211667	1-R52, 53
AA530627	21-36	BA574795	2-1x	EC389237	12-C2	EJ299305	20-43	ER211667	3-R52
AA530741	19-18	BC545725	22-29	EC389474	2-C6	EJ354936	20-64	ER211667	9-R14
AA530785	20-2	BF530763	19-20	EC389474	5-C6	EJ367986	20-16	ER211667	9-R22
AA530820	20-15	BT379991	1-T5	EC403468	6-C1, 2	EJ378944	20-55	ER211667	11-R12
AA530910	20-44	BT380384	1-T6	EC411827	12-C4	EJ437310	13-J1, 2	ER211667	12-R11
AA530954	21-55	BT443610	1-T7	EC419231	1-C8	EJ437321	13-J3, 4	ER211757	1-R26
AA530976	22-4x	BT444137	20-31x	EC419231	1-C37	EJ437321	14-J1, 2	ER211757	3-R20, 21
AA531145	22-5	BT561903	21-8	EC423562	1-C36	EJ514034	19-16	ER211757	3-R29
AA531156	22-8	BT570464	21-9x	EC424708	9-C5	EJ514034	21-37	ER211757	3-R42
AA531167	22-9	EA549448	22-45x	EC450055	5-C9	EJ514822	18-2	ER211757	3-R46
AA531360	21-53	EA576112	22-39x	EC450066	11-C7	EJ514822	22-43x	ER211757	4-R5
AA531371	21-54	EC220127	6-C6, 7	EC450527	1-C23	EJ539447	21-28	ER211757	9-R2
AA532102	21-18	EC220410	8-C1	EC450527	1-C33	EJ539662	1-4	ER211757	9-R9
AA533384	20-13	EC220432	2-C8, 9	EC450527	1-C52	EJ539662	2-2	ER211757	9-R12
AA539537	22-36x	EC220432	2-C14, 15	EC450527	3-C11	EJ539662	3-2	ER211757	9-R16
AA541517	22-6	EC220432	5-C10	EC450527	3-C13, 14	EJ539662	5-2	ER211757	11-R2
AA541528	22-7	EC220678	5-C2	EC450527	3-C16	EJ539662	6-5	ER211757	11-R14
AA542992	4-2	EC220994	9-C7, 8	EC450527	3-C20, 21	EJ539662	7-2	ER211757	12-R7
AA544926	20-19	EC220994	15-C2, 3	EC455354	3-C1	EJ539662	8-2	ER211757	12-R10
AA545117	6-3	EC228745	4-C10	EC455354	12-C8	EJ539662	10-2	ER211858	1-R24
AA545580	21-50	EC250841	1-C35	EC476324	11-C2	EJ539662	11-2	ER211858	1-R33
AA545624	4-3x	EC250841	1-C49, 50	EC476324	11-C8	EJ539662	12-2	ER211858	11-R9
AA545668	20-6	EC250841	2-C2	EC479621	11-C1	EJ539662	15-2	ER211950	5-R3
AA545894	22-38	EC250975	2-C12, 13	EC479621	11-C3 to 6	EJ539662	16-2	ER212016	4-R12
AA545905	22-12	EC290520	3-C18, 19	EC479621	11-C9	EJ539662	18-3	ER212016	20-33x
AA547435	20-21x	EC290520	4-C4	EC479621	12-C6	EJ539662	22-44x	ER212264	1-R27
AA547446	20-20	EC290520	4-C6	EC492142	1-C34	EJ539673	9-2	ER212264	3-R9
AA557886	20-45	EC290520	5-C4	EC492142	1-C38 to 42	EJ539673	17-2	ER212264	6-R10
AA560081	22-50x	EC290531	1-C27	EC492142	1-C44 to 47	EJ539763	20-41	ER212264	6-R12
AA560092	22-49x	EC313108	1-C26	EC492142	1-C51	EJ539785	20-27	ER212477	1-R32
AA569586	22-40x	EC313108	1-C30	EC492142	1-C53	EJ539796	20-39	ER212477	5-R9, 10
AA569610	22-46x	EC313108	3-C2	EC517138	5-C1	EJ550012	4-6	ER212681	1-R2
AF510298	21-14x	EC313108	9-C1	EC522516	12-C5	EJ550012	13-3	ER212681	1-R5
AF510300	21-13	EC313108	9-C3	EC522551	3-C12	EJ550012	14-2	ER212681	1-R11, 12
AZ531055	22-3	EC313108	9-C9	EC522551	3-C15	EJ550067	21-34	ER212681	1-R14
AZ544836	14-3	EC313121	5-C11	EC522551	3-C17	EJ550912	22-47x	ER212681	1-R34
AZ544950	20-52	EC313244	2-C3	EC523282	15-C1	EJ551035	21-27	ER212681	2-R24
AZ545130	21-6	EC320051	1-C43	EC538435	3-C3	EJ551057	21-47	ER212872	1-R4
AZ545141	21-7	EC321221	4-C2	EC551160	6-C10	EJ551340	20-42	ER212883	1-R7
AZ545163	21-40	EC321221	6-C3, 4	EC551160	7-C1 to 5	EJ552778	22-48x	ER212883	1-R56
AZ545512	19-12	EC329771	1-C25	EC551160	19-7x	EJ553948	21-52	ER212883	2-R20, 21
AZ545523	19-13	EC329850	1-C48	EC551441	1-C1 to 3	EJ556143	20-22	ER212883	2-R25, 26
AZ545534	11-3	EC329850	5-C3	EC551441	1-C5 to 7	EJ556143	21-51	ER212883	3-R7, 8
AZ545545	19-22	EC329883	3-C5	EC551441	1-C9 to 17	EJ557717	21-46	ER212883	4-R6
AZ545556	21-44	EC329883	3-C10	EC551441	1-C19, 20	EJ557728	19-15	ER212883	4-R11
AZ545567	13-2	EC329883	5-C7	EC551441	1-C28, 29	EJ557728	21-48	ER212883	6-R1
AZ545578	21-25	EC331817	6-C5	EC551441	1-C31, 32	EJ557910	11-4	ER212883	9-R11
AZ545591	21-22x	EC331828	2-C1	EC551463	2-C16, 17	EJ557932	9-3x	ER212883	15-R3
AZ545613	21-45x	EC331828	2-C4	EC556176	4-C9	EJ561982	21-29	ER213030	3-R31
AZ545635	21-2	EC336104	1-C18	EC557616	16-C1 to 10	EL539684	20-4x	ER213030	3-R33
AZ545646	21-3	EC336104	1-C54	EC557627	6-C8, 9	EL539684	20-17x	ER213096	5-R15
AZ545657	21-5	EC336104	4-C7	EC557695	21-26	EL550045	20-8	ER213467	9-R6
AZ545670	20-7	EC336216	1-C21, 22	EC565896	19-8x	EM539706	20-12	ER213467	15-R4
AZ545681	21-49	EC336216	1-C24	ED219464	1-D9 to 13	EM551248	20-10	ER213715	4-R1
AZ545736	22-13x	EC337500	2-C10, 11	ED219464	2-D1, 2	EM551250	20-11	ER304290	1-R13
AZ545760	20-1	EC337500	3-C8	ED219464	15-D1	EM558044	20-18	ER304290	1-R16, 17
AZ545771	21-1	EC339096	2-C5	ED224526	6-D1 to 8	EO443766	2-L1	ER304290	11-R15
AZ545782	19-1	EC346735	9-C2	ED224526	6-D11 to 14	EO443777	2-L2	ER304290	12-R8
AZ547356	21-39	EC346735	9-C10	ED379855	1-D6, 7	EO539820	1-L1, 2	ER304402	1-R46
AZ547367	21-24x	EC346735	11-C10	ED428264	1-D1 to 5	ER211320	3-R40	ER304402	1-R50
BA560496	9-1x	EC350706	2-C7	ED514721	1-D8	ER211320	4-R8	ER304402	1-R55
BA560531	14-1x	EC350706	2-C18, 19	ED539976	6-D9, 10	ER211465	1-R6	ER306360	3-R45
BA560654	5-1x	EC350706	5-C8	ED551395	1-T2	ER211465	1-R21, 22	ER306843	1-R8
BA560676	7-1x	EC350875	3-C9	ED551428	1-T4	ER211465	1-R42	ER306843	3-R6
BA560687	8-1x	EC354947	4-C1	ED556514	4-D1	ER211465	1-R47	ER306887	1-R3
BA562184	12-1x	EC364947	4-C5	ED558033	7-D1 to 4	ER211465	1-R51	ER306887	1-R10
BA562195	17-1x	EC368256	1-C4	ED558033	8-D1 to 4	ER211465	2-R8	ER306887	3-R4
BA562206	10-1x	EC368335	3-C7	EF277424	22-41x	ER211465	2-R14, 15	ER306887	4-R18
BA562217	11-1x	EC368335	12-C1	EF424811	22-33x	ER211465	5-R1	ER306887	5-R5
BA562228	15-1x	EC368357	3-C4	EF459843	22-42x	ER211465	5-R4	ER306887	6-R4
BA562230	16-1x	EC368357	12-C3	EF562544	22-51x	ER211465	5-R17	ER306887	6-R11
BA562241	13-1x	EC373296	4-C12	EF562680	22-52x	ER211465	9-R1	ER324202	4-R9
BA562274	18-1x	EC377212	4-C3	EF562691	22-32x	ER211465	9-R15	ER334923	4-R2
BA562320	1-1x	EC377212	5-C5	EF563657	22-35x	ER211465	9-R21	ER336442	1-R31
BA562331	1-3x	EC377212	12-C7	EF575234	22-34x	ER211465	11-R5	ER336442	1-R35, 36
BA562342	3-1x	EC379214	9-C4	EI443744	2-IC1	ER211667	1-R1	ER336442	1-R49
BA563894	1-2x	EC379214	9-C6	EI469967	1-IC1 to 4	ER211667	1-R23	ER336442	1-R54
BA570396	6-1x	EC379721	3-C6	EJ233370	20-25	ER211667	1-R40	ER336442	2-R7

# INDEX

Parts No.	Ref. No. & Symbol No.	Parts No.	Ref. No. & Symbol No.	Parts No.	Ref. No. & Symbol No.	Parts No.	Ref. No. & Symbol No.	Parts No.	Ref. No. & Symbol No.
ER336442	3-R1	ER363644	11-R17	ET539987	5-TR1,2,3	ZS552622	20-54		
ER336442	3-R3	ER364994	21-33x	ET539987	9-TR1	ZS553904	20-38x		
ER336442	3-R22	ER371946	1-R15	ET539987	9-TR2 to 4	ZS564390	4-5		
ER336442	4-R3	ER371946	2-R22, 23	ET539987	11-TR1 to 3	ZS570385	20-28		
ER336442	6-R8, 9	ER371946	16-R1 to 10	ET539987	12-TR1	ZW259503	4-4x		
ER336442	5-R16	ER379517	1-R43	ET551406	1-T1	ZW270191	13-4		
ER336442	9-R3	ER379552	3-R19	ET551564	4-TR2, 3	ZW270191	14-4		
ER336442	9-R7	ER379596	4-R19	ET552870	2-TR1	ZW273778	20-37x		
ER336442	9-R10	ER380406	1-FL4	ET556020	4-TR4	ZW273802	20-36x		
ER336442	9-R13	ER380417	1-FL4	ET562048	4-TRS, 6	ZW273881	21-12x		
ER336442	11-R3, 4	ER380711	2-R16 to 19	EV380215	1-VR1	ZW273914	21-10x		
ER336442	11-R16	ER380711	11-R1	EV383398	4-VR1	ZW273914	20-48x		
ER336442	12-R9	ER380711	11-R13	EV409858	4-VR2	ZW348107	20-30x		
ER336442	16-R11, 12	ER380711	12-R6	EV551452	1-VR2	ZW419646	22-16x		
ER342933	3-R10	ER380755	3-R27	EV555941	9-VR2, 3	ZW426622	4-8x		
ER342933	3-R16	ER380755	9-R19	EV557741	19-14	ZW493312	22-25x		
ER342933	3-R41	ER380913	1-R18	EV557842	10-VR8	ZW510660	21-11		
ER343078	2-R9, 10	ER381723	3-R39	EV557897	20-53	ZW530673	21-21		
ER343078	3-R44	ER391961	1-R57	EV557921	9-VR1	ZW548010	22-30		
ER343078	11-R11	ER392850	1-R30	EV557921	17-VR1	ZW551373	20-50x		
ER343135	6-R5	ER392850	11-R8	EW315448	20-60x	ZW552824	22-31		
ER346544	3-R15	ER399060	1-R19	EW486797	20-59x	ZW556132	20-49x		
ER346544	3-R17	ER399060	3-R48	EW524845	20-61x	ZW561993	19-19x		
ER346544	12-R4	ER406912	4-R7	EW540112	20-58	ZW562015	20-35		
ER346601	2-R12, 13	ER406912	9-R20	EZ246936	20-63x				
ER346601	2-R27, 28	ER407103	4-R14	EZ382263	20-51				
ER346601	3-R26	ER407316	3-R18	EZ382263	20-62				
ER346601	3-R30	ER407316	3-R43	EZ436217	22-18				
ER346601	3-R32	ER407316	3-R47	EZ486257	20-56				
ER346601	3-R51	ER419040	2-R4	EZ545602	21-43x				
ER346601	5-R14	ER419556	3-R28	EZ585134	19-27x				
ER346601	6-R13	ER423753	3-R25	MR530651	19-4				
ER346994	2-R1	ER427961	19-24x	MR530651	21-19				
ER346994	3-R49	ER428567	20-57x	MR530662	19-3				
ER346994	5-R13	ER429996	12-R5	MR530662	21-20x				
ER346994	10-R1, 2	ER430007	4-R4	MR530706	21-16				
ER346994	12-R1	ER430042	9-R4	MS530752	19-17				
ER347073	1-R20	ER430086	1-R28	MZ229138	19-11				
ER349784	3-R37	ER430086	3-R2	MZ259233	20-5				
ER349828	6-R3	ER430086	5-R11	SA377190	22-15x				
ER349828	15-R1	ER435303	9-R8	SE546208	22-2				
ER349942	1-R39	ER452542	4-R20	SK531213	22-28				
ER349942	3-R23	ER452777	21-32x	SK531224	22-21				
ER349907	1-R25	ER489780	21-38x	SK531281	22-22				
ER349907	1-R29	ER496214	2-R3	SK531314	22-19				
ER349907	5-R7	ER496214	2-R6	SK531347	22-24				
ER350100	11-R6	ER512201	2-FL1, 2	SK531358	22-26				
ER350100	12-R3	ER536984	6-R6	SK545027	22-23				
ER352045	3-R36	ER536984	6-R7	SK547964	22-20				
ER352045	3-R38	ER539818	1-FL1 to 3	SM531336	20-9x				
ER352045	9-R5	ER551621	20-34x	SP545747	22-1				
ER357412	4-R13	ER551632	4-R21	SP545758	20-23				
ER357412	4-R15	ER554681	6-R6	SP569621	20-24x				
ER357456	1-R37	ER556064	4-R16, 17	ZG549011	21-17x				
ER357456	1-R41	ER557796	15-R5, 6	ZS321298	4-7				
ER357456	1-R58	ER559034	14-R1 to 4	ZS321298	21-15				
ER357456	2-R11	ER565828	6-FR1	ZS371856	13-5				
ER357456	3-R11 to 14	ES320016	20-32	ZS371856	19-6				
ER357456	5-R8	ES468448	19-5	ZS371856	20-14				
ER357456	5-R12	ES513922	2-SW1	ZS371856	21-41				
ER357456	11-R10	ES557763	19-25	ZS379350	22-37x				
ER357491	1-R9	ES561914	19-9	ZS379451	20-47				
ER357491	2-R2	ES561925	19-10	ZS406416	21-56x				
ER357491	2-R5	ES561936	19-23	ZS446422	22-27x				
ER357535	1-R48	ES561960	15-SW1	ZS447761	20-40				
ER357535	2-R29, 30	ES591107	11-SW1	ZS447761	21-42				
ER357535	9-R17	ES591142	16-SW1	ZS447772	6-4				
ER357535	15-R2	ES591153	12-SW1	ZS447772	19-26				
ER357570	3-R5	ET380834	1-TR3 to 7	ZS447772	20-3				
ER357570	3-R34, 35	ET427860	1-TR9 to 11	ZS447772	21-4				
ER357570	12-R2	ET452531	6-TR1	ZS447772	22-14x				
ER361528	1-R38	ET453486	2-TR2, 3	ZS447805	21-30				
ER361528	3-R50	ET453611	6-TR3	ZS447805	22-10x				
ER361528	5-R2	ET517994	6-TR2	ZS447840	21-57x				
ER361528	11-R7	ET517994	6-TR4	ZS447840	22-11x				
ER361620	9-R18	ET520334	1-TR1, 2	ZS462936	19-21x				
ER362272	5-R6	ET539122	6-TR5	ZS463375	22-17x				
ER362441	6-R2	ET539987	2-TR4, 5	ZS530684	19-2				
ER362520	3-R24	ET539987	3-TR1 to 6	ZS530684	21-23x				
ER362520	4-R10	ET539987	4-TR1	ZS552611	20-26				

---

SECTION 3

**SCHEMATIC DIAGRAM**

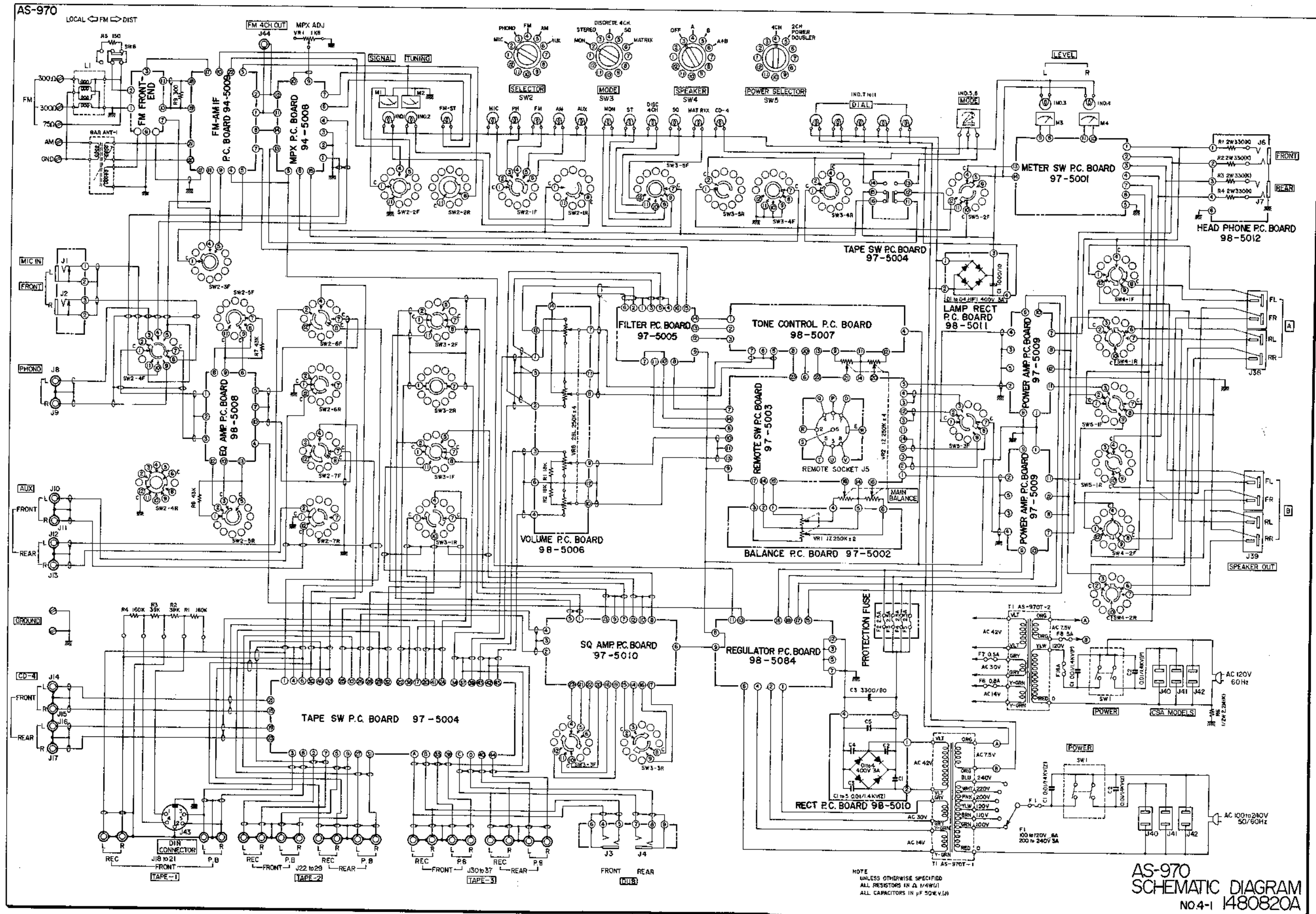

AS-970

LOCAL FM DIST

NOTE  
UNLESS OTHERWISE SPECIFIED  
ALL RESISTORS IN  $\Omega$  1/4W(1)  
ALL CAPACITORS IN pF 50WV(1)

AS-970  
SCHEMATIC DIAGRAM  
NO.4-1 1480820A

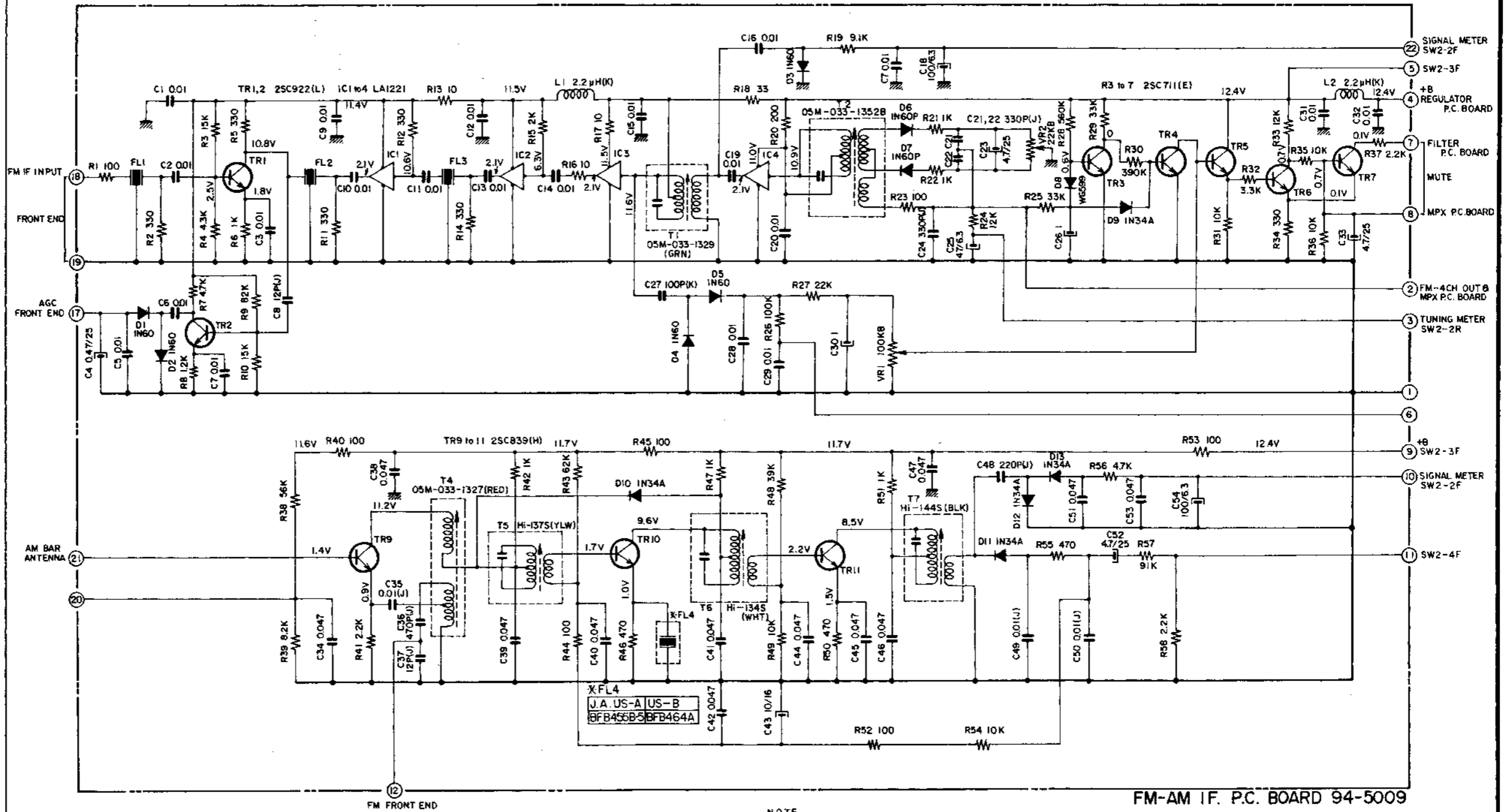

AS-970  
 SCHEMATIC DIAGRAM  
 NO.4-2 1480821A  
 2C



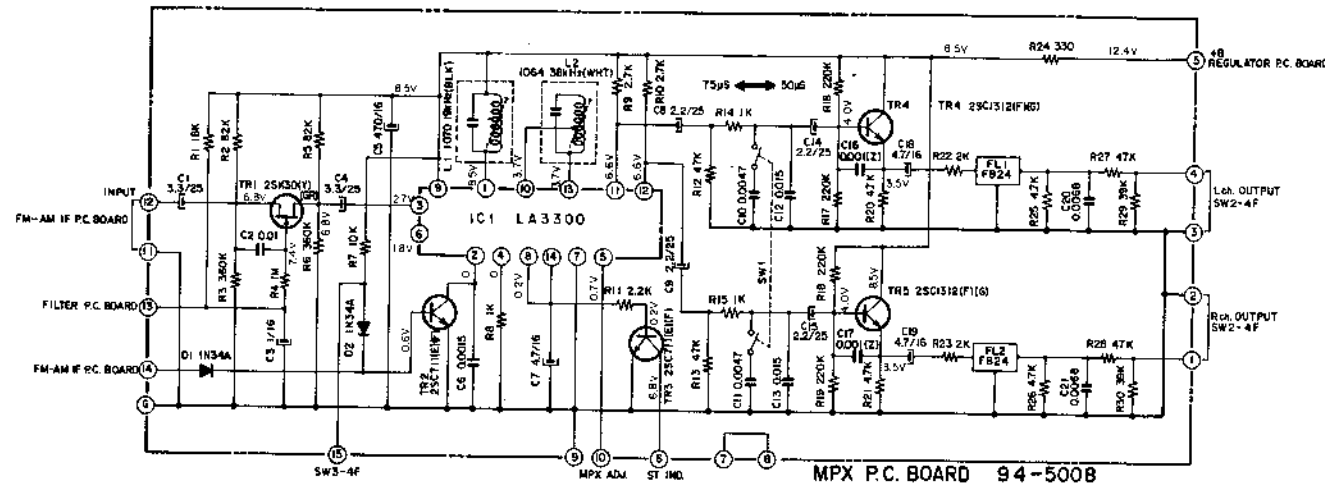

NOTE  
UNLESS OTHERWISE SPECIFIED  
ALL RESISTORS IN  $\Omega$  1/4W(1/2)  
ALL CAPACITORS IN  $\mu$ F 50W.V.(1)

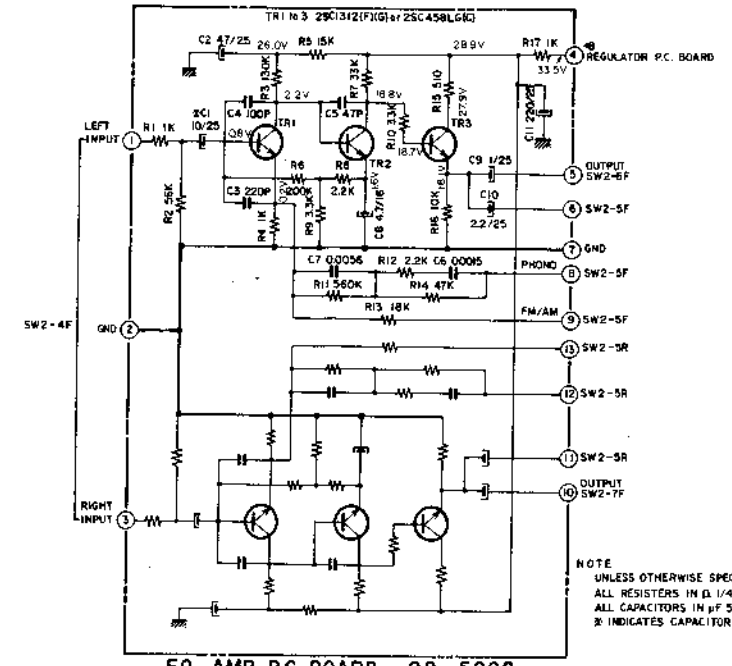

NOTE  
UNLESS OTHERWISE SPECIFIED  
ALL RESISTORS IN  $\Omega$  1/4W(1/2)  
ALL CAPACITORS IN  $\mu$ F 50W.V.(1)  
\* INDICATES CAPACITOR LOW LEAKAGE CAPACITORS

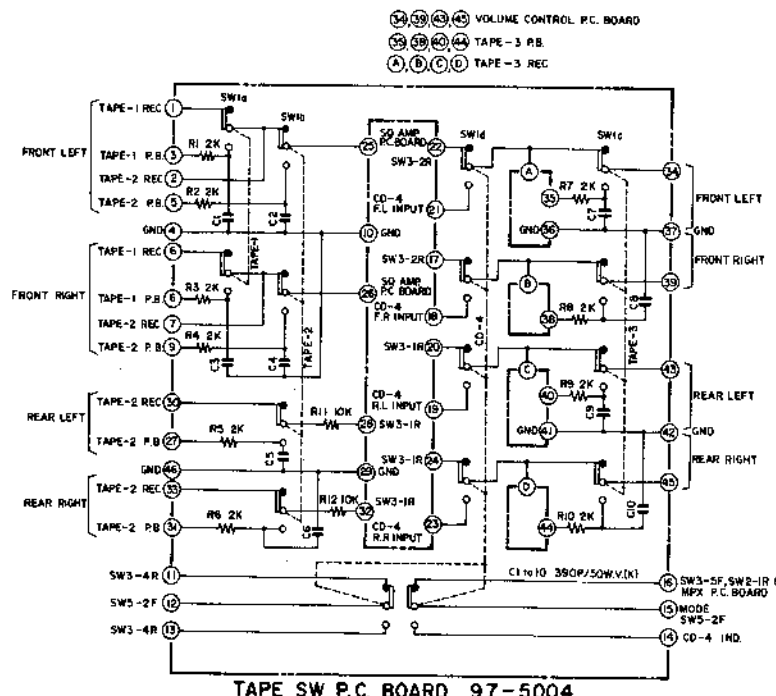

NOTE  
UNLESS OTHERWISE SPECIFIED  
ALL RESISTORS IN  $\Omega$  1/4W(1/2)

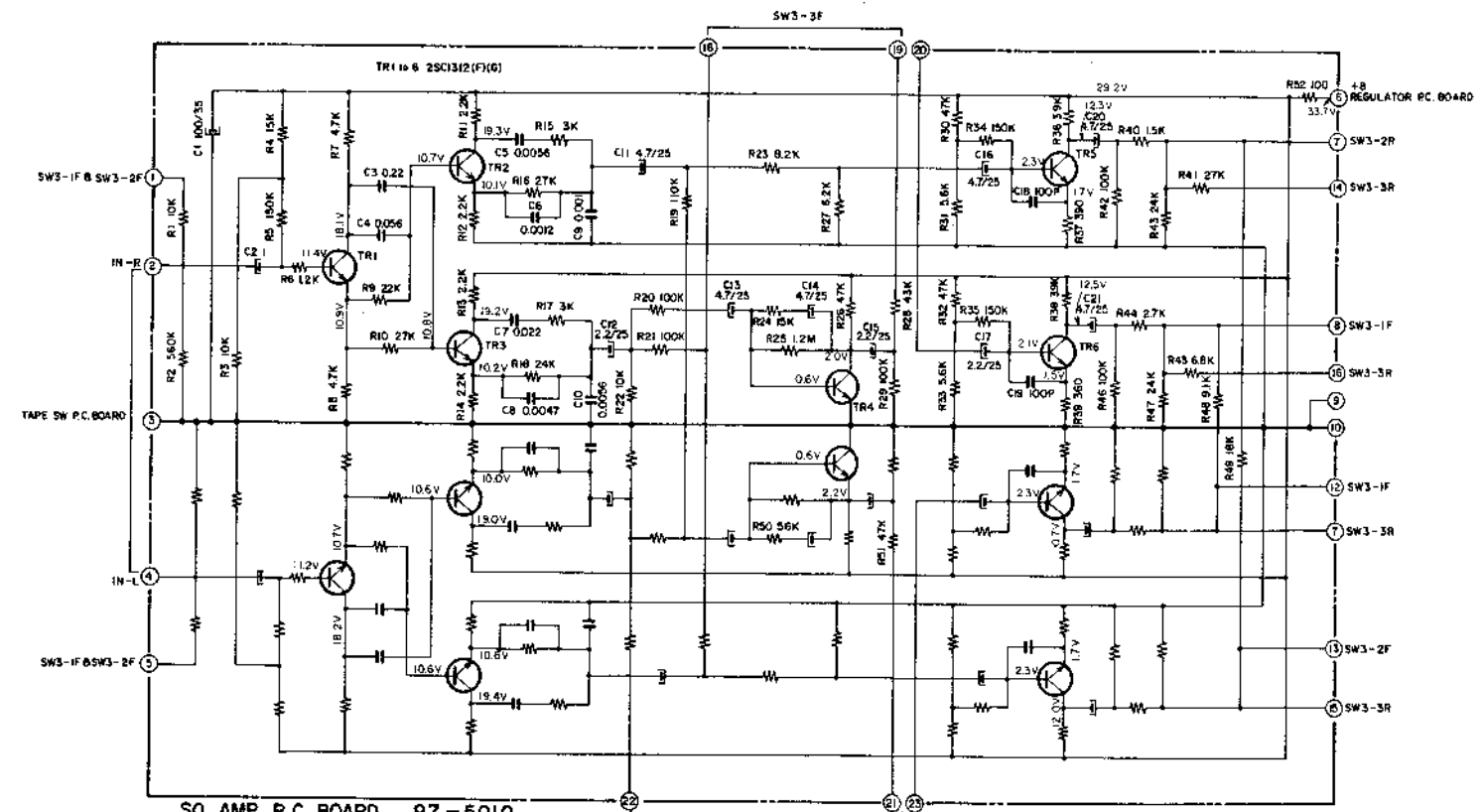

NOTE  
UNLESS OTHERWISE SPECIFIED  
ALL RESISTORS IN  $\Omega$  1/4W(1/2)  
ALL CAPACITORS IN  $\mu$ F 50W.V.(1)

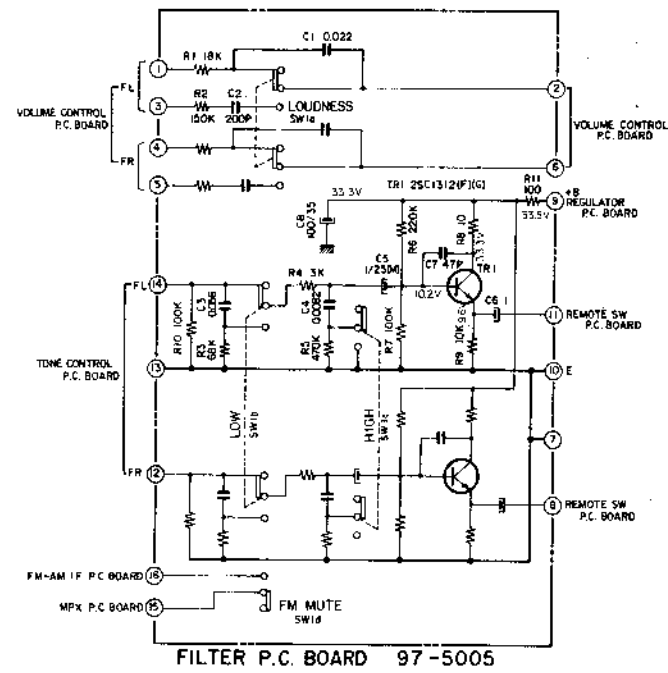

FILTER P.C. BOARD 97-5005

NOTE  
UNLESS OTHERWISE SPECIFIED  
ALL RESISTORS IN  $\Omega$  (1/4W/1)  
ALL CAPACITORS IN  $\mu$ F (50WV/1)

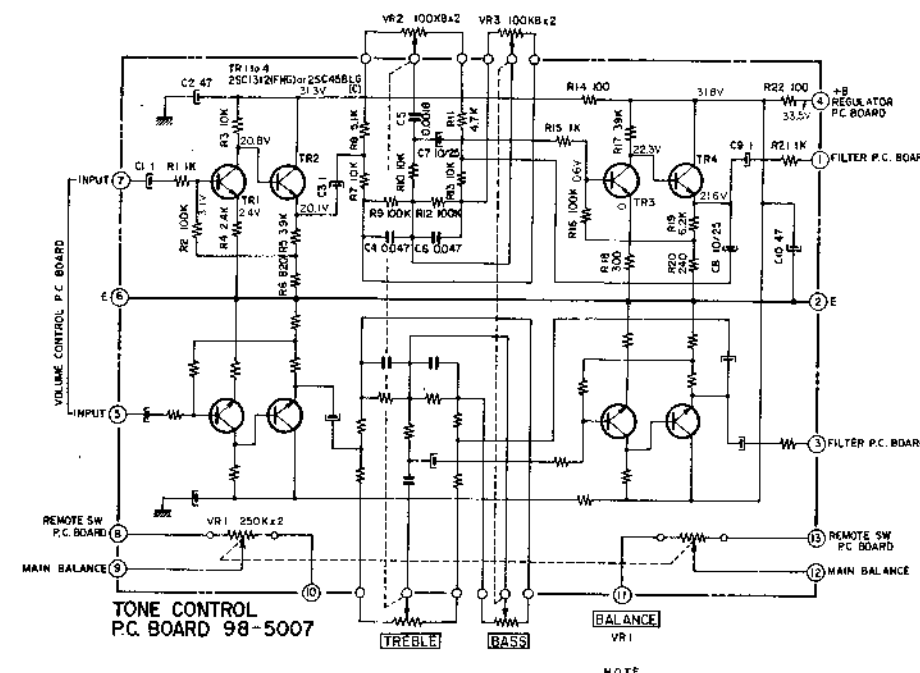

TONE CONTROL P.C. BOARD 98-5007

NOTE  
UNLESS OTHERWISE SPECIFIED  
ALL RESISTORS IN  $\Omega$  (1/4W/1)  
ALL CAPACITORS IN  $\mu$ F (50WV/1)

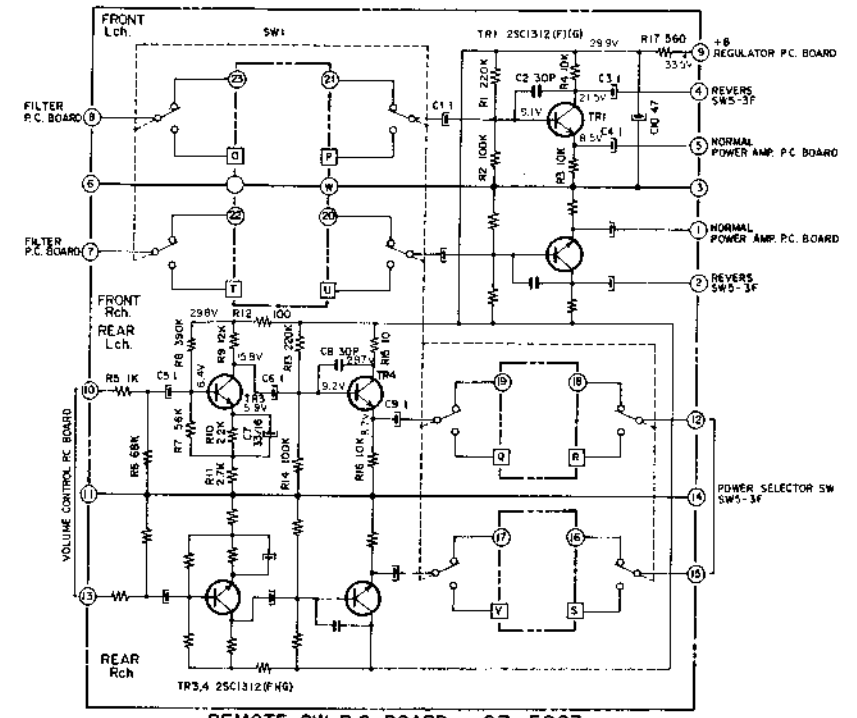

REMOTE SW P.C. BOARD 97-5003

NOTE  
UNLESS OTHERWISE SPECIFIED  
ALL RESISTORS IN  $\Omega$  (1/4W/1)  
ALL CAPACITORS IN  $\mu$ F (50WV/1)  
[Symbol] [Symbol] UNCONNECTED REMOTE SOCKET TERMINAL JS

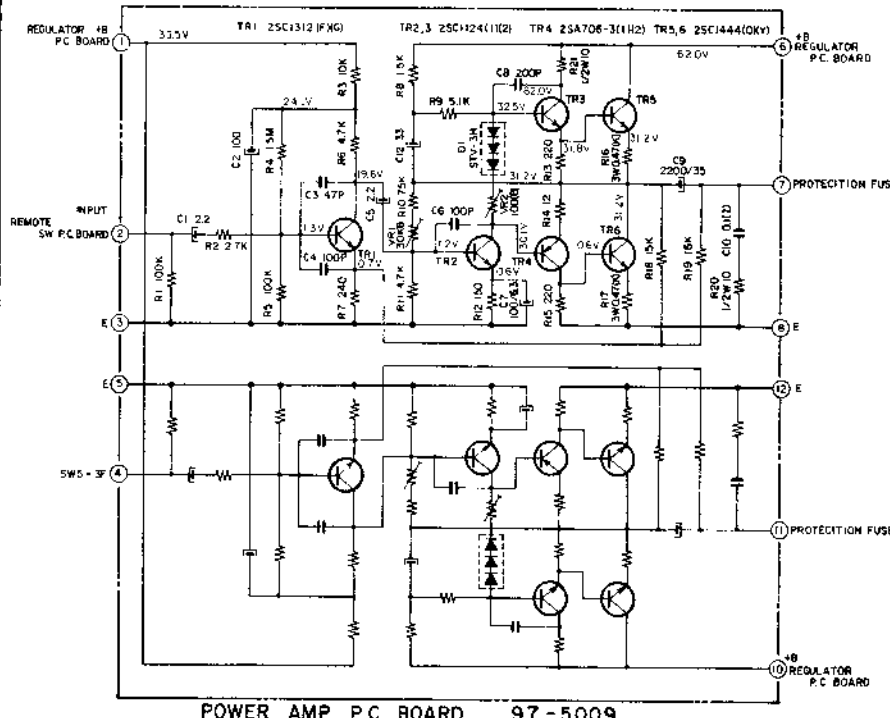

POWER AMP. P.C. BOARD 97-5009

NOTE  
UNLESS OTHERWISE SPECIFIED  
ALL RESISTORS IN  $\Omega$  (1/4W/1)  
ALL CAPACITORS IN  $\mu$ F (50WV/1)

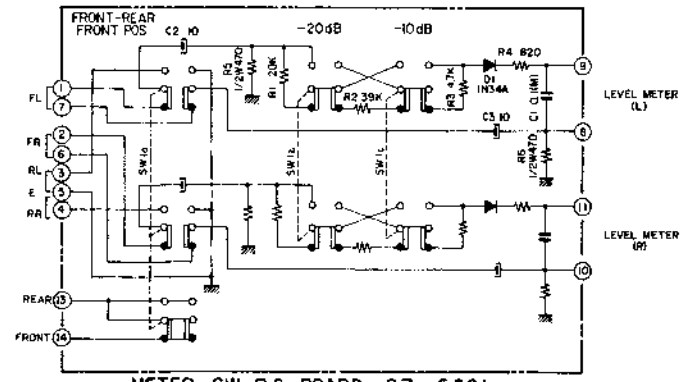

METER SW P.C. BOARD 97-5001

NOTE  
UNLESS OTHERWISE SPECIFIED  
ALL RESISTORS IN  $\Omega$  (1/4W/1)  
ALL CAPACITORS IN  $\mu$ F (25WV/1)

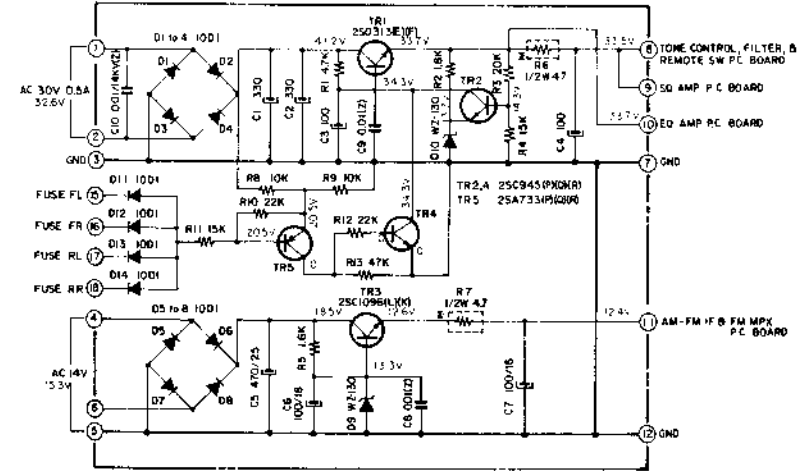

REGULATION P.C. BOARD 98-5084

NOTE  
UNLESS OTHERWISE SPECIFIED  
ALL RESISTORS IN  $\Omega$  (1/4W/1)  
ALL CAPACITORS IN  $\mu$ F (50WV/1)  
IN CASE OF CSA MODELS  
R6 1/2W4.7  $\rightarrow$  R1 1/4W 100K  
R7 1/2W4.7  $\rightarrow$  R6 1/2W 2.2K