

## STEREO TAPE DECK

### MODEL GX-370D

SECTION 1	SERVICE MANUAL .....	2
SECTION 2	PARTS LIST .....	45
SECTION 3	SCHEMATIC DIAGRAM .....	80

---

SECTION 1

**SERVICE MANUAL**

TABLE OF CONTENTS

I.	SPECIFICATIONS .....	3
II.	MEASURING METHOD .....	4
III.	DISMANTLING OF UNIT .....	6
IV.	MECHANISM ADJUSTMENTS .....	8
V.	HEAD ADJUSTMENTS .....	11
VI.	AMPLIFIER ADJUSTMENTS .....	13
VII.	TRANSPORT MECHANISM .....	16
VIII.	SERVO MOTOR OPERATING PRINCIPLES .....	31
IX.	DIFFERENTIATION OF SYSTEM CONTROL SCHEMATIC DIAGRAM & P.C. BOARD .....	33
X.	COMPOSITE VIEWS OF COMPONENTS .....	34

# I. SPECIFICATIONS

An asterisk next to a figure indicates the minimum guaranteed performance.

TRACK SYSTEM	4 track 2-channel stereo/monaural system	
REEL CAPACITY	Up to 7" reel	
TAPE SPEED	7-1/2 and 3-3/4 ips $\pm 0.5\%$	
WOW AND FLUTTER	Less than 0.07% (*0.1%) RMS at 7-1/2 ips Less than 0.1% (*0.15%) RMS at 3-3/4 ips	
FREQUENCY RESPONSE	30 to 26,000 Hz (*30 to 24,000 Hz) $\pm 3$ dB at 7-1/2 ips (AKAI S.R.T. Tape) 30 to 24,000 Hz (*30 to 22,000 Hz) $\pm 3$ dB at 7-1/2 ips (Regular Tape) 30 to 22,000 Hz (*30 to 19,000 Hz) $\pm 3$ dB at 3-3/4 ips (AKAI S.R.T. Tape) 30 to 19,000 Hz (*30 to 18,000 Hz) $\pm 3$ dB at 3-3/4 ips (Regular Tape)	
SIGNAL TO NOISE RATIO	Better than 50 dB (*48 dB)	
DISTORTION	Less than 1.5% (*2%) at 7-1/2 ips 1,000 Hz "0" VU recording Less than 3% at 3-3/4 ips 1,000 Hz "0" VU recording	
CROSS TALK	Better than 70 dB (Monaural) Better than 45 dB (Stereo)	
ERASE RATIO	Better than 70 dB	
BIAS FREQUENCY	103 kHz $\pm 5$ kHz	
BIAS LEAK	Less than -20 VU	
HIGH FREQUENCY DEVIATION (between left and right channel)	Within 3 dB, using a 8,000 Hz 3-3/4 ips recorded tape at 7-1/2 ips	
INPUTS	Mic input	0.7 mV Impedance: 10 k $\Omega$
	Line input	70 mV Impedance: 150 k $\Omega$
	Din input	7 mV (low) and 70 mV (high)
OUTPUTS	Line output	1.228V (4 $\pm 1.5$ dB) Impedance: 100 $\Omega$ , using a 250 Hz "0" VU recorded tape
	Din output	0.4V
RECORDING CAPACITY	60 min. stereo recording, using a 1,200 ft. tape at 7-1/2 ips	
FAST FORWARD & REWIND TIME	68/83 sec., using a 1,200 ft. tape at 60/50 Hz	
MOTORS	Capstan Motor	2-speed servo control outer rotor motor Type: SCM2-24 Revolutions: 520 r.p.m. at 7-1/2 ips 260 r.p.m. at 3-3/4 ips
	Reel Motor	Two 6-pole eddy current outer rotor motors Type: 24X0-II Revolutions: 930 r.p.m. at 50 Hz 1120 r.p.m. at 60 Hz
HEADS	Combination Recording & Erase Head	Type: RE4-1 Gap: 4 $\mu \pm 15\%$ , 0.2x2 mm Impedance: 1,800 $\Omega$ at 100 kHz 210 $\Omega \pm 15\%$ at 100 kHz
	Playback Head	Type: P4-200 Gap: 1.75 $\mu \pm 15\%$ Impedance: 3 $\pm 1$ k $\Omega$ at 1 kHz
TRANSISTORS	2 ... 2SA564(R) 8 ... 2SC458LG(B)(C) 4 ... 2SC871(F) 6 ... 2SC968(3) 1 ... 2SC1013 3 ... TSC9000-1(B)(C)	4 ... 2SC454(C) 16 ... 2SC711(D)(E) 17 ... 2SC945(Q)(R)(S) 2 ... 2SC971(2)(3)(red) 2 ... 2SD234(Y)
DIODES	27 ... 1N34A 3 ... 10D4 1 ... 10DC-1(red)	17 ... 10D1 2 ... 10DC-1(black)
IC	2 ... LD-3141	
THERMISTORS	1 ... 1N359A	1 ... RD9A
VARISTOR	1 ... TH201	
POWER SUPPLY	100 to 240V AC, 50/60 Hz	
POWER CONSUMPTION	130 W	
INSULATION RESISTANCE	More than 50 M $\Omega$	
INSULATION DURABILITY	1,000V AC for more than 1 min. duration	
DIMENSIONS	445 (W) x 503 (H) x 252 (D) mm (18.2 x 20.5 x 10.3")	
WEIGHT	25.5 kg (56 lbs.)	

NOTE: Specifications subject to change without notice.

## II. MEASURING METHOD

### 1. TAPE SPEED DEVIATION

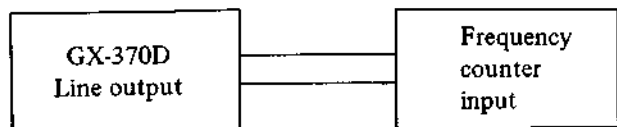


Fig. 1

As shown in Fig. 1, connect a Frequency Counter to the Line Output of Model GX-370D. Playback a 1,000 Hz pre-recorded test tape. Take a Frequency Counter reading at the beginning, middle, and end of tape winding during playback. The maximum value of these respective readings will represent tape speed deviation.

### 2. WOW AND FLUTTER

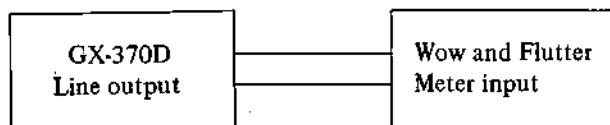


Fig. 2

#### Method A

As shown in Fig. 2, connect the Line Output of Model GX-370D to the Input of a Wow and Flutter Meter. Playback a 3,000 Hz pre-recorded test tape and take a Wow and Flutter Meter reading at the beginning, middle, and end of tape winding. The maximum value of these respective readings will represent the Wow and Flutter.

#### Method B

Supply a 3,000 Hz sine wave signal from an Audio Frequency Oscillator and make a recording on a blank tape at the beginning, middle, and end of tape winding. Rewind and playback the resultant signal. Measure Wow and Flutter with a Wow and Flutter Meter. (The Wow and Flutter value of Method B will be close to twice that of Method A.)

### 3. FREQUENCY RESPONSE

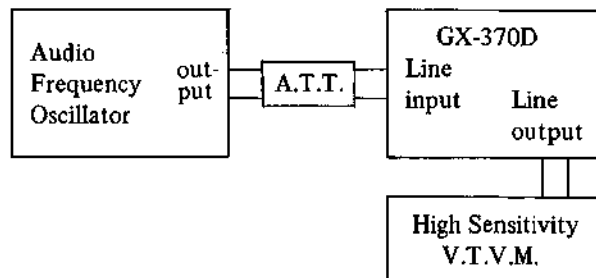


Fig. 3

For measuring Frequency Response, connect instruments as shown in Fig. 3 and proceed as follows:

- 1) Supply a 1,000 Hz sine wave signal to the Line Input of Model GX-370D from an Audio Frequency Oscillator through an Attenuator.
- 2) Set recorder to recording mode and turn recording level control volume and line output level control volume to maximum. Adjust attenuator to obtain a +4 dB V.T.V.M. reading.
- 3) Under conditions described in 2) above, readjust attenuator so that the Line Output is -16 dB, and record 30 to 24,000 Hz spot frequencies.
- 4) Rewind tape and playback from the beginning. Take V.T.V.M. spot frequency readings and plot values on a graph.

**NOTE:** When measuring Frequency Response, new tape should be used.

### 4. SIGNAL TO NOISE RATIO

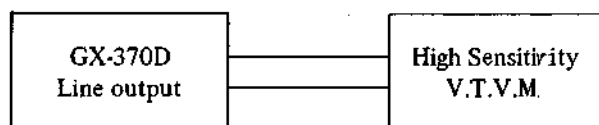


Fig. 4

As shown in Fig. 4, connect a High Sensitivity V.T.V.M. to the Line output of Model GX-370D. Playback a 250 Hz "0" VU pre-recorded test tape and measure the output. Then remove the tape and measure the noise level under the same condition. Convert each of the measured values into decibels.

## 5. TOTAL HARMONIC DISTORTION

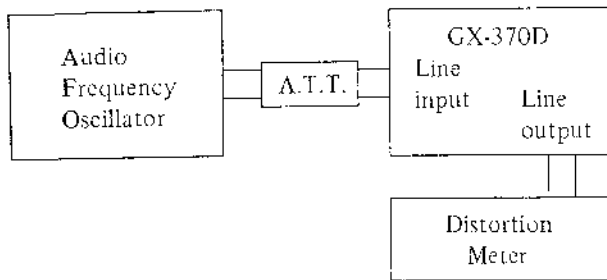


Fig. 5

Connect the measuring instruments as shown in Fig. 5 and record a 1,000 Hz sine wave signal at "0" VU. Playback the resultant signal and measure the overall distortion factor. Measure the noise level of the tape recorder without the tape. Connect the Audio Frequency Oscillator directly to the distortion meter for measurement of the distortion factor of the oscillator. The required distortion factor can be obtained from the results of the above measurement by the following formula:

$$d_0 = d - d_1 - d_2$$

where,  $d_0$  - Required distortion factor  
 $d$  - Overall distortion factor  
 $d_1$  - Noise level  
 $d_2$  - Distortion factor of the oscillator

**NOTE:** When measuring the distortion factor, new tape should be used.

## 6. CROSS TALK (Cross talk between the tracks)

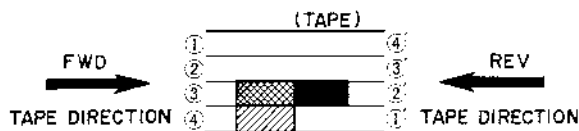


Fig. 6

As shown in Fig. 6, first record a 1,000 Hz sine wave signal on Track No. 3 at +3 VU level. Next, record under a non-input condition. Then, playback the tape on Tracks No. 3 and 1 (reversed condition of tape) through the B.P.F. (band pass filter sensitivity... 1:1) and obtain a ratio between the two from the following formula:

$$C = 20 \log \frac{E_0}{E_2 - E_1} \text{ (dB)}$$

where,  $C$  - Desired cross talk ratio (dB)  
 $E_0$  - 1,000 Hz signal output level  
 $E_2$  - 1,000 Hz cross talk level  
 $E_1$  - Non-input signal recorded level

Fig. 7

## 7. ERASE RATIO

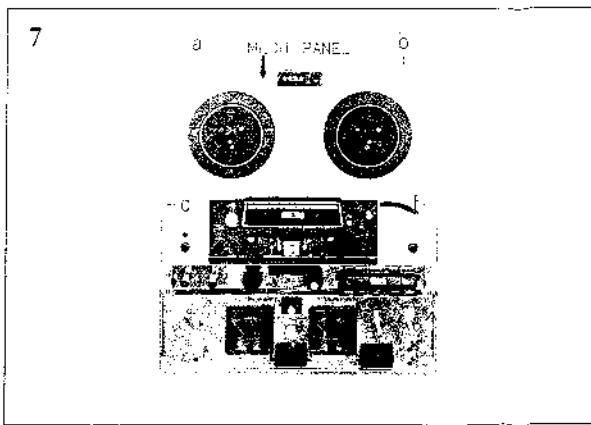
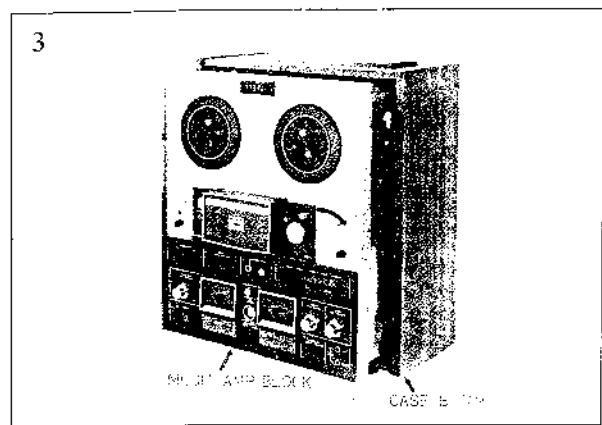
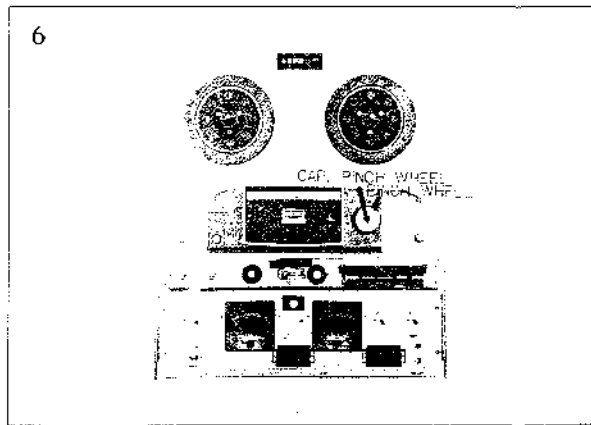
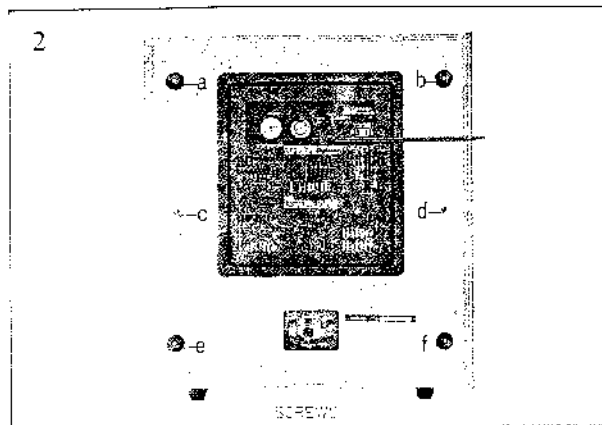
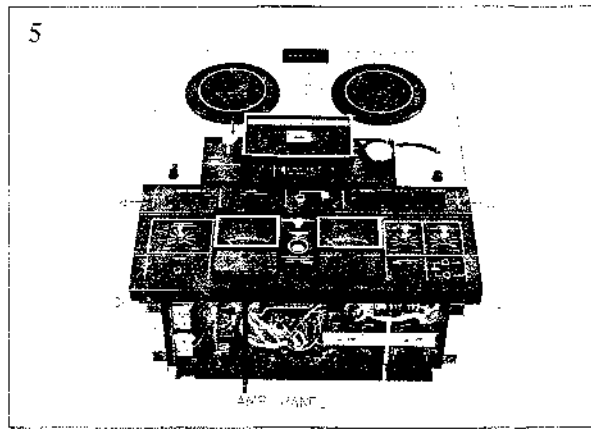
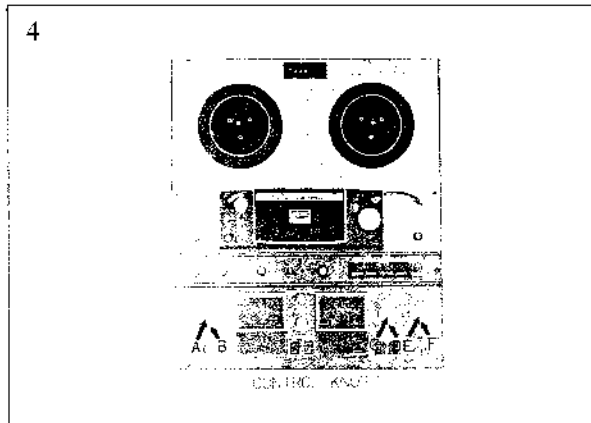
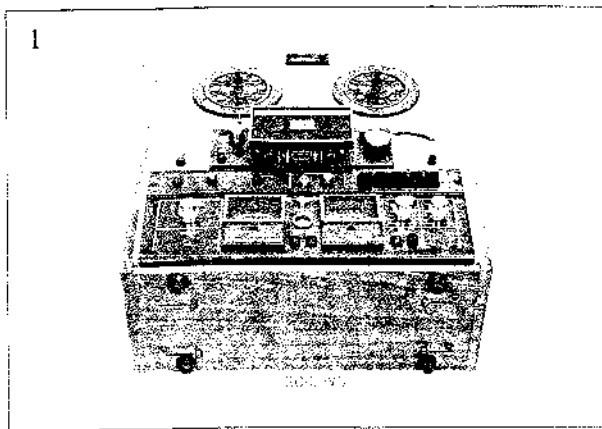
As shown in Fig. 4, connect a High Sensitivity V.T.V.M. to the Line Output of Model GX-370D. Playback a virgin tape and take a V.T.V.M. reading of the output level. Next, record a 1,000 Hz sine wave signal at +3 dB, then playback this recorded signal and take a V.T.V.M. reading of the output level. Next, using this pre-recorded tape, record under a non-input condition and take a reading of the noise output level of the erased signal and obtain a ratio between the two from the following formula:

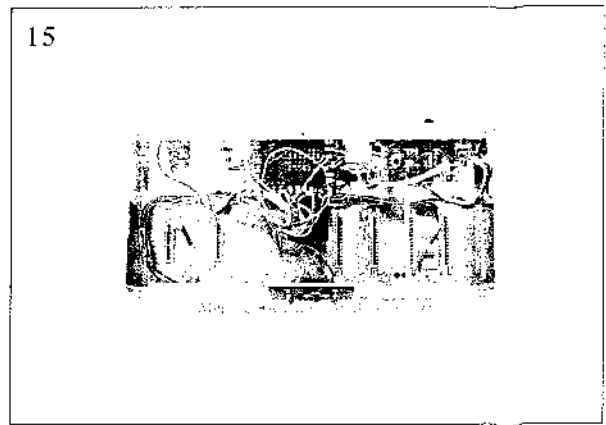
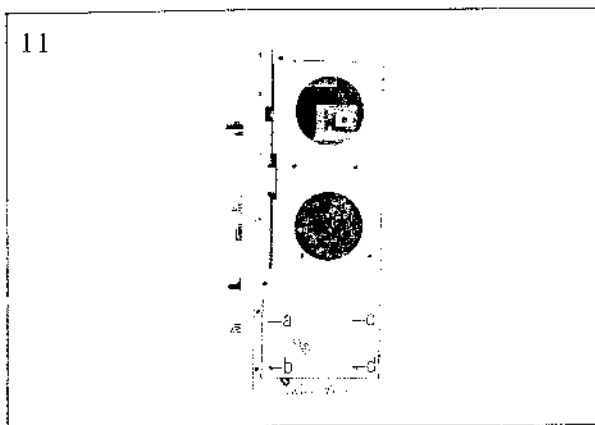
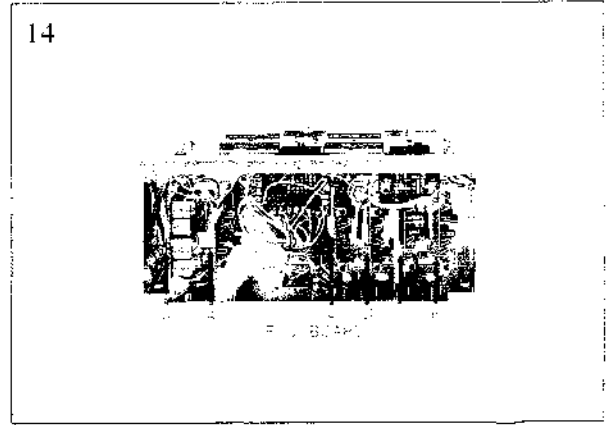
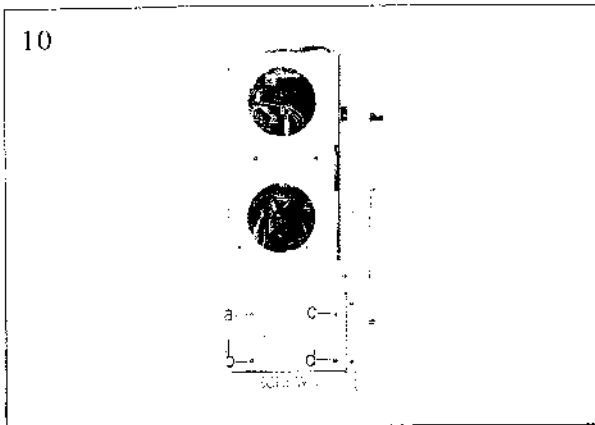
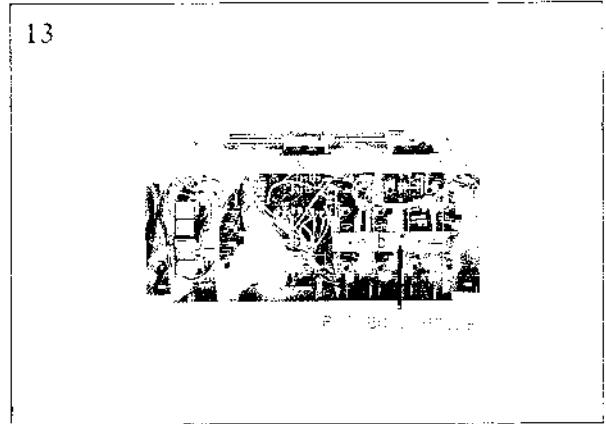
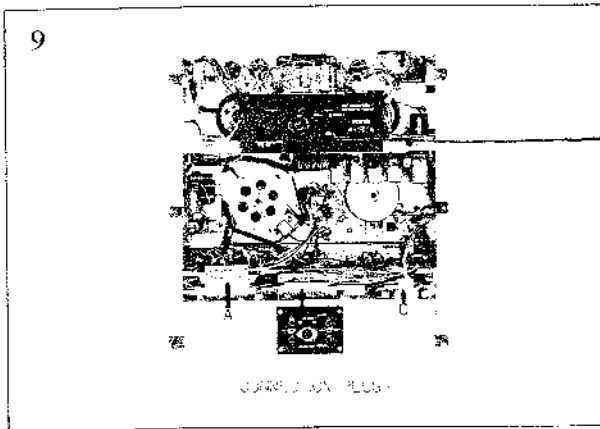
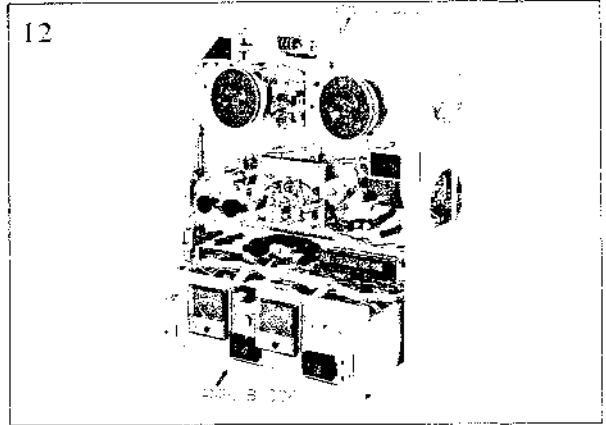
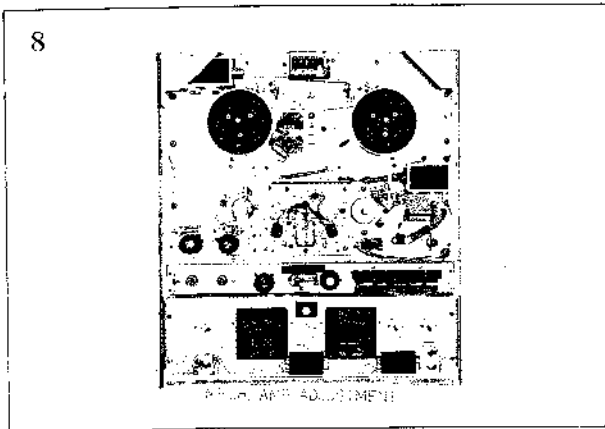
$$E_r = 20 \log \frac{E_0}{E_2 - E_1} \text{ (dB)}$$

where,  $E_r$  - Desired erase ratio (dB)  
 $E_0$  - 1,000 Hz signal output level  
 $E_2$  - Non-input signal recorded level  
 $E_1$  - Virgin tape noise output level

### III. DISMANTLING OF UNIT

In case of trouble, etc. necessitating disassembly, please disassemble in the order shown in photographs. Re-assemble in reverse order.





## IV. MECHANISM ADJUSTMENTS

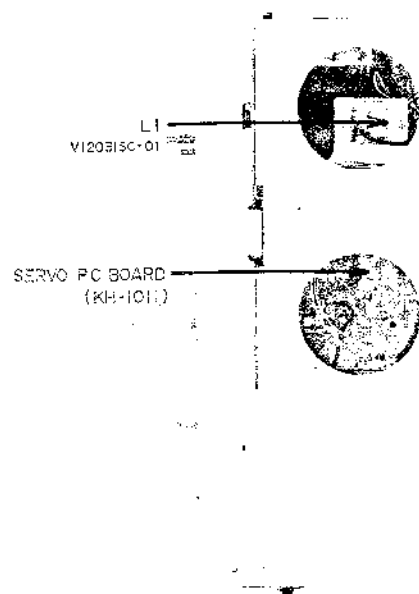


Fig. 8

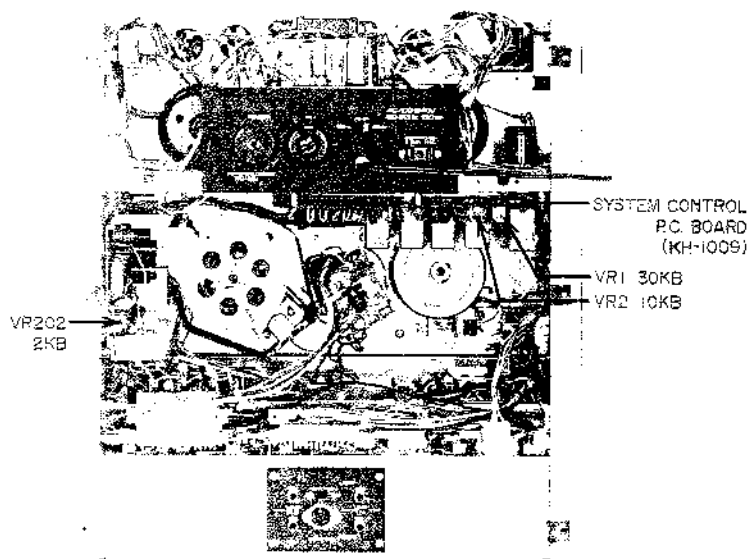


Fig. 9

### 1. TAPE SPEED ADJUSTMENT (SERVO MOTOR CIRCUIT ADJUSTMENT)

- 1) Connect a Frequency Counter to the Line Output.
- 2) Set the Tape Speed Selector to 3-3/4 ips and playback a 1,000 Hz pre-recorded tape.
- 3) Adjust the core of Coil L1 (V12031SC-01) shown in Fig. 8 to obtain a Frequency Counter indication of 500 Hz  $\pm 1\%$ .
- 4) When the 3-3/4 ips tape speed adjustment is completed, set the Tape Speed Selector to 7-1/2 ips and adjust Servo P.C. Board (KH-1011) semi-fixed resistor VR-202 (2k B) shown in Fig. 9 to obtain a Frequency Counter indication of 1,000 Hz  $\pm 1/-0.5\%$ .

**NOTE:** When making tape speed adjustment, it is necessary to make the low speed (3-3/4 ips) adjustment first.

### 2. DIRECT FUNCTION TIME CONSTANT ADJUSTMENT (See Fig. 9)

- 1) FWD  $\leftrightarrow$  REV Time Constant  
Adjust System Control P.C. Board (KH-1009) semi-fixed resistor VR-1 (30k B) so that the time constant to and from FWD and REV mode is about 3 seconds.
- 2) F-FWD or RWD to FWD or REV Time Constant  
Adjust System Control P.C. Board (KH-1009) semi-fixed resistor VR-2 (10k B) so that the time constant from F-FWD or RWD to FWD or REV mode is about 1.5 seconds.

**NOTE:** In making the adjustments outlined in Items (1) and (2) above, when the machine is switched from the various modes to FWD or REV, it is important that proper capstan motor revolutions be attained by the time the pinch wheel contacts the capstan.



### 3. BRAKE TENSION ADJUSTMENT

Use a 60 mm diameter tape wound on a 5" reel and measure the brake tension with a tension gauge. (See Fig. 10) Ideal tape tension is 350 grams.

Brake tension adjustment can be made as follows:

- 1) Adjust position of suspended springs (d) (d').
- 2) Loosen screws (a) (b) as well as (a') (b') and adjust the vertical (upper/lower) position of spring suspension metal (c) (c').
- 3) Loosen screws (e) (f) as well as (e') (f') and adjust the horizontal (left/right) position of brake band suspension metal (g) (g').

Adjust as described above until proper brake tension is attained. (Refer to Fig. 11)

**NOTE:** In making brake tension adjustment, when the machine is set to other than stop mode, confirm that the brake band definitely does not touch the cloth tape on the brake drum.

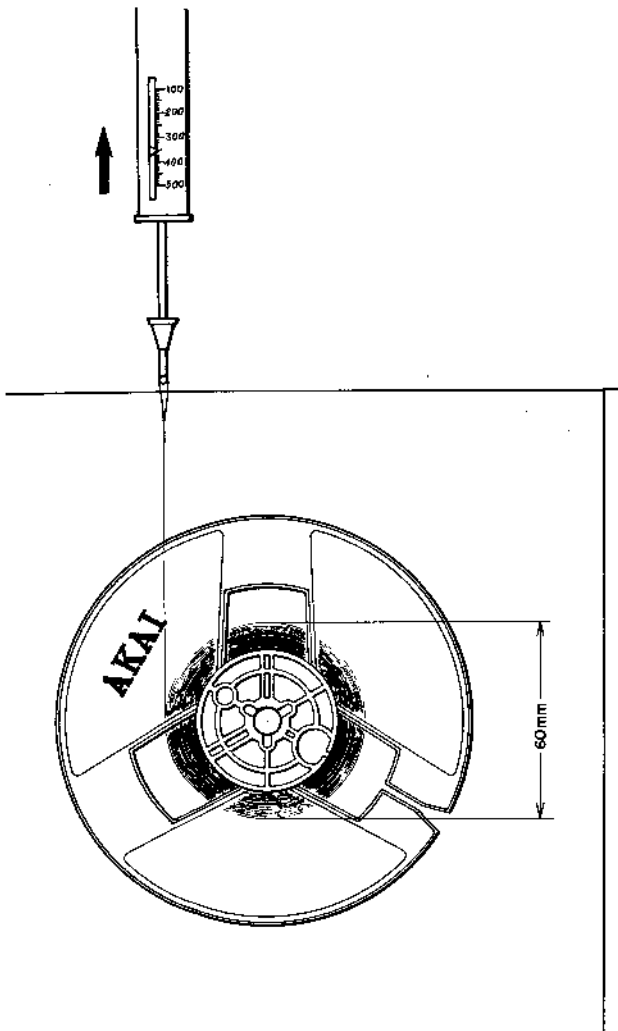


Fig. 10

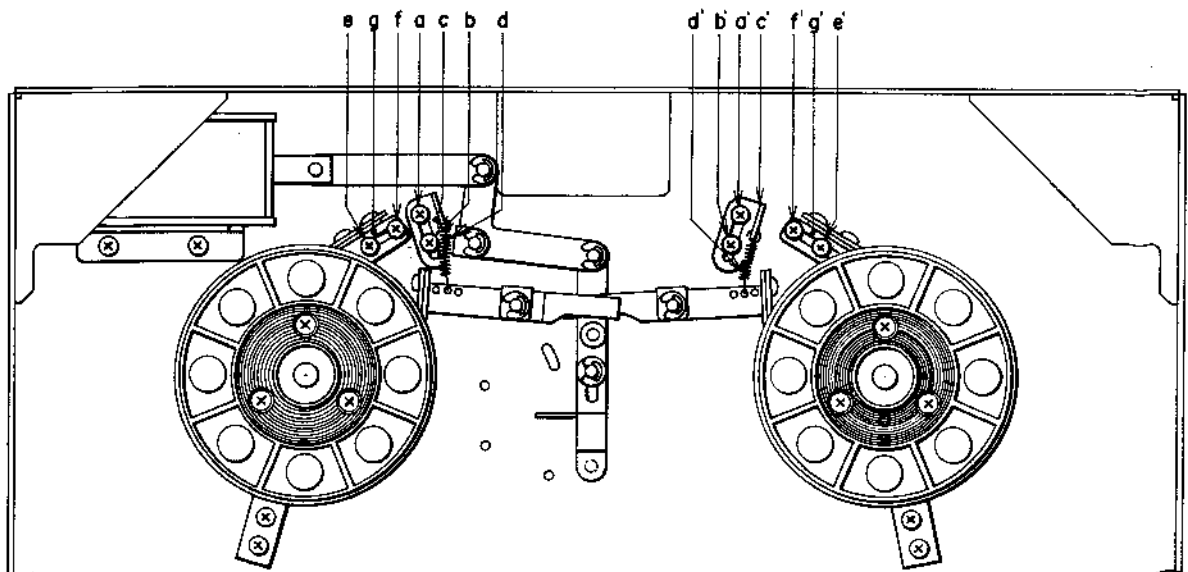


Fig. 11

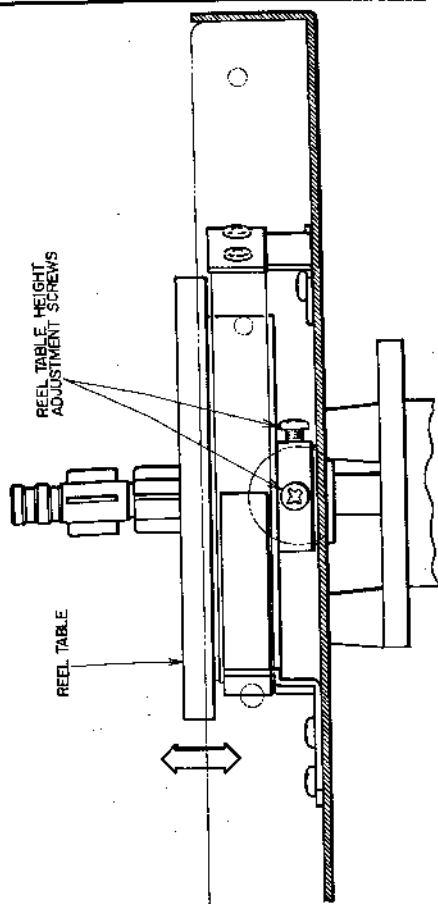


Fig. 12

#### 4. REEL HEIGHT ADJUSTMENT

Loosen the reel table height adjustment screws shown in Fig. 12 and adjust by moving the reel table in the direction of arrow and positioning so that the tape winds in the center of the reel.

#### 5. PINCH WHEEL PRESSURE MEASUREMENT AND ADJUSTMENT

Use a tension gauge and measure the pinch wheel pressure as shown in Fig. 13. Read the value on the tension gauge as soon as the pinch wheel separates from the tape and tape travel stops. Ideal pinch wheel pressure is 1.5 kg. Pinch wheel pressure can be increased or decreased by adjusting screws (a) (b) shown in Fig. 13.

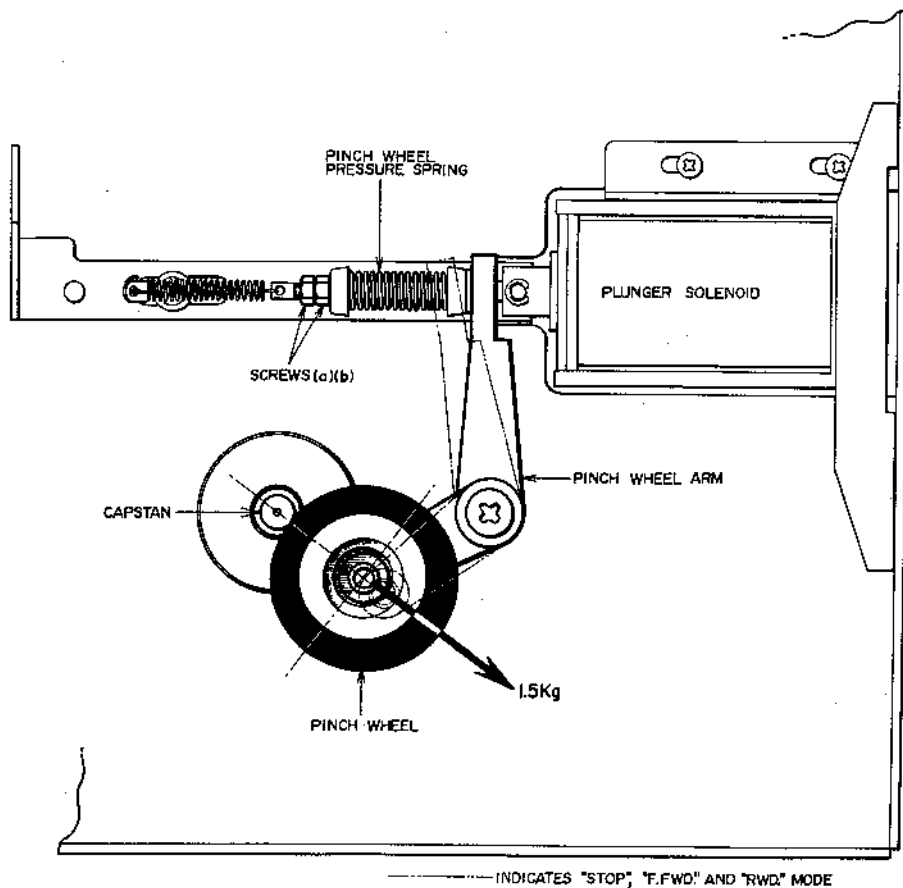


Fig. 13

## V. HEAD ADJUSTMENTS

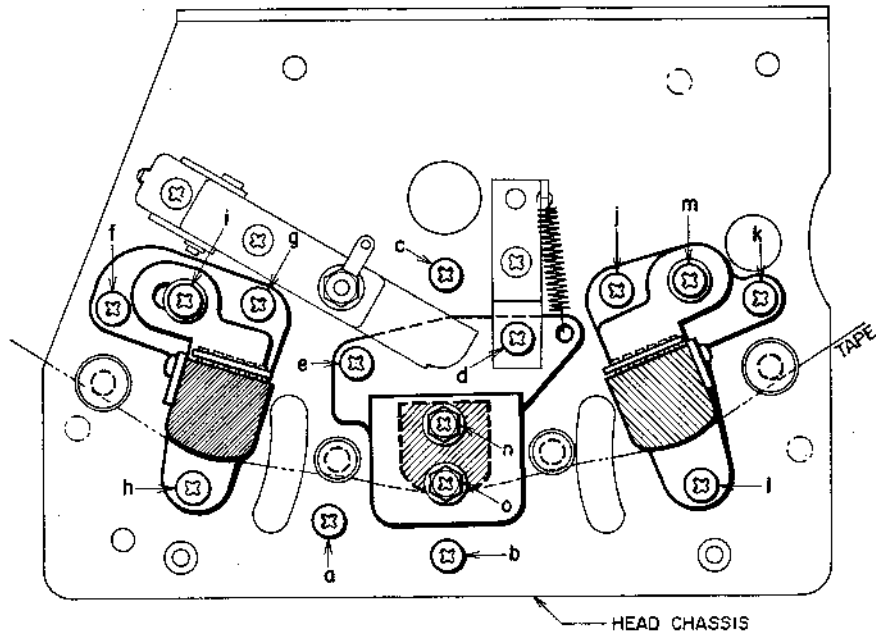


Fig. 14

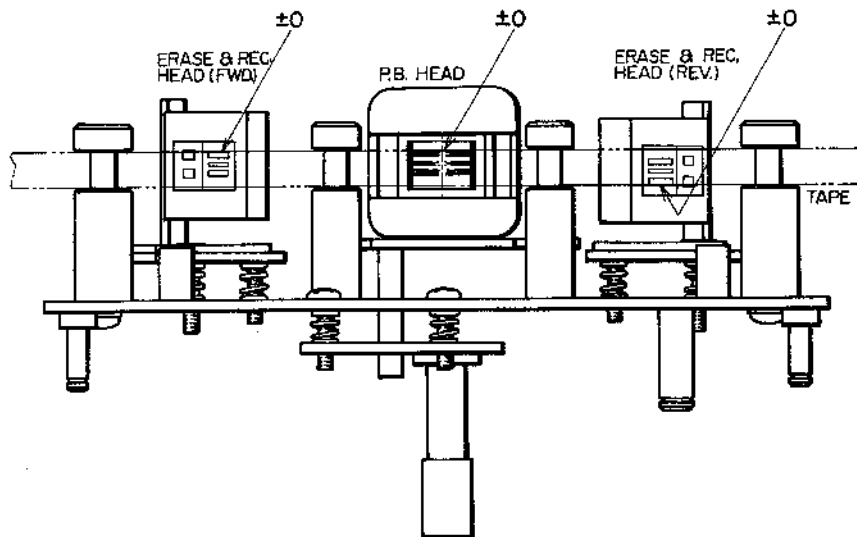


Fig. 15

### 1. HEAD HEIGHT ADJUSTMENT

(See Figs. 14 & 15)

#### 1) Playback Head

- a) For FWD playback mode head height adjustment, during FWD playback, turn head height control screw (d) to left and right until the upper edge of the tape as it passes the head is aligned with the upper edge of channel 1 head core.
- b) For REV playback mode head height adjustment, during REV playback, turn head height control screw (e) to left and right until the lower edge of the tape as it passes the head is aligned with the lower edge of channel 1 head core.

#### 2) Recording and Erase Heads

- a) For FWD recording and erase head height adjustment, at FWD playback mode, adjust head height control screws (f) (g) and (h) by turning to left and right until the upper edge of the tape as it passes the head is aligned with the upper edge of channel 1 recording head core.
  - b) For REV recording and erase head height adjustment, at REV playback mode, adjust head height control screws (j) (k) and (l) by turning to left and right until the lower edge of the tape is aligned with the lower edge of channel 1 recording head core.
- 3) When making the various head height adjustments, confirm that the tape and head core surface is at a right angle with the head chassis during tape travel.

---

## 2. HEAD AZIMUTH ALIGNMENT

### ADJUSTMENT (See Figs. 14 & 15)

#### 1) Playback Head

- a) Connect a High Sensitivity V.T.V.M. to the line output and playback a test tape (Ampex Alignment Tape, 8,000 Hz at 3-3/4 ips) at 7-1/2 ips.
- b) At FWD playback mode, turn adjustment screws (a) and (b) to left and right until the line output level of both channels is maximum.
- c) When Item (b) adjustment is completed, loosen screws (n) and (o) and move the head gap side of the playback head to the left and right. When the tension increases on the supply reel side and the line output level of both channels do not fluctuate, fix screws (n) and (o) to maintain this condition.
- d) At REV playback mode, make the same adjustment as outlined above to attain maximum line output of both channels.

#### 2) Recording and Erase Heads

- a) Connect an Audio Frequency Oscillator to the line input and connect a High Sensitivity V.T.V.M. to the line output and load a blank tape.
- b) Set the Monitor Switch to TAPE position and record a 16,000 Hz signal at -10 dB recording level.
- c) At FWD recording mode, adjust Azimuth Alignment screw (f) so that the line output level of both channels is maximum and does not fluctuate.
- d) After completing Item (c) adjustment, loosen screw (i) and move the head gap side of the recording head to left and right. When the tension increases on the supply reel side and the line output level of both channels do not fluctuate, fix screw (i) to maintain this condition.
- e) At REV recording mode, make the same adjustment as outlined above by adjusting screws (k) and (m) to attain maximum line output of both channels without fluctuation.

3. To obtain the best results make adjustments outlined in Paragraphs 1 and 2 above two or three times. Also new blank tape should be used.

## VI. AMPLIFIER ADJUSTMENTS

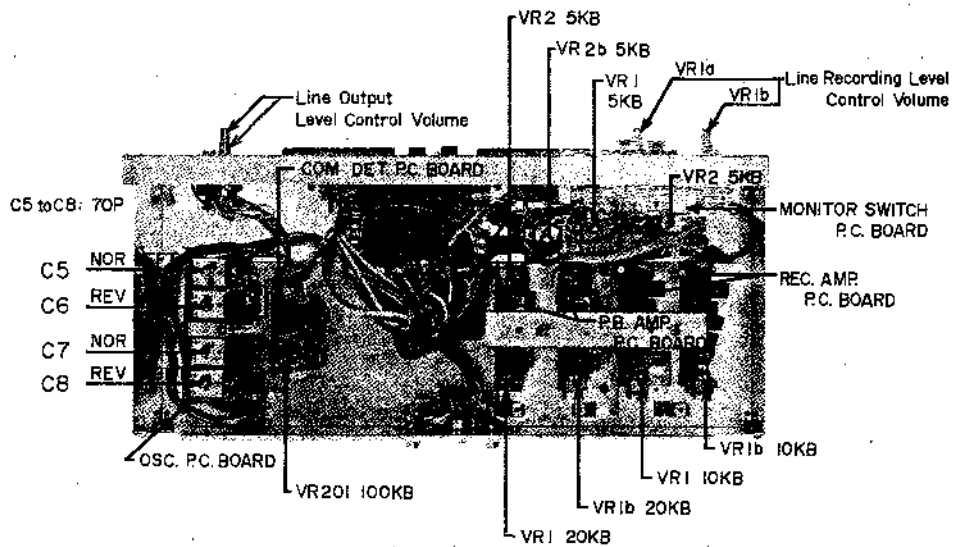


Fig. 16

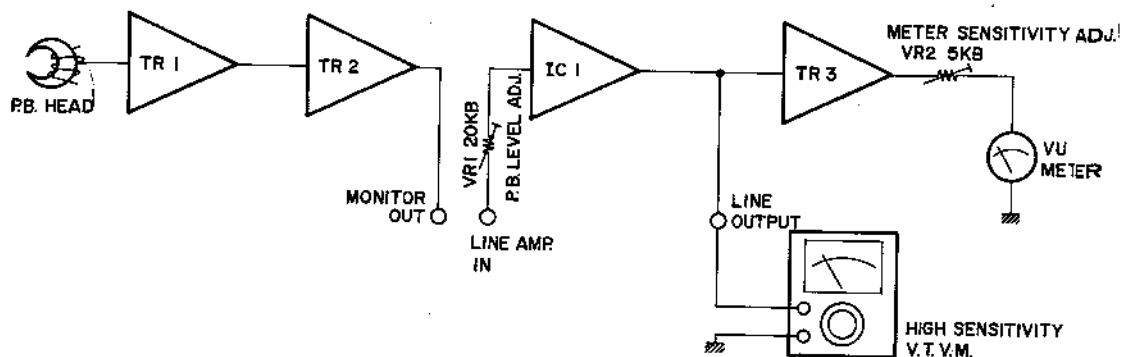


Fig. 17 P.B. AMP. BLOCK DIAGRAM

### 1. PLAYBACK LEVEL ADJUSTMENT

(See Fig. 16)

- 1) Connect a High Sensitivity V.T.V.M. to the line output.
- 2) Set Tape Speed Selector to 7-1/2 ips.
- 3) Depress both LEFT and RIGHT Track Selector Switches.
- 4) Set Monitor Switch to TAPE position and Line Output Level Controls to maximum.
- 5) Playback a 250 Hz, 7-1/2 ips pre-recorded tape.
- 6) With P.B. Amp. P.C. Board (KH-5014) semi-fixed resistors VR-1 and VR-1b (20k B), set the line output level of both channels to  $4 \pm 1.5$  dB.

### 2. VU METER SENSITIVITY ADJUSTMENT

(See Fig. 16)

Adjust P.B. Amp. P.C. Board (KH-5014) semi-fixed resistors VR-2 and VR-2b (5k B) to obtain a VU meter indication of "0" VU on both channels.

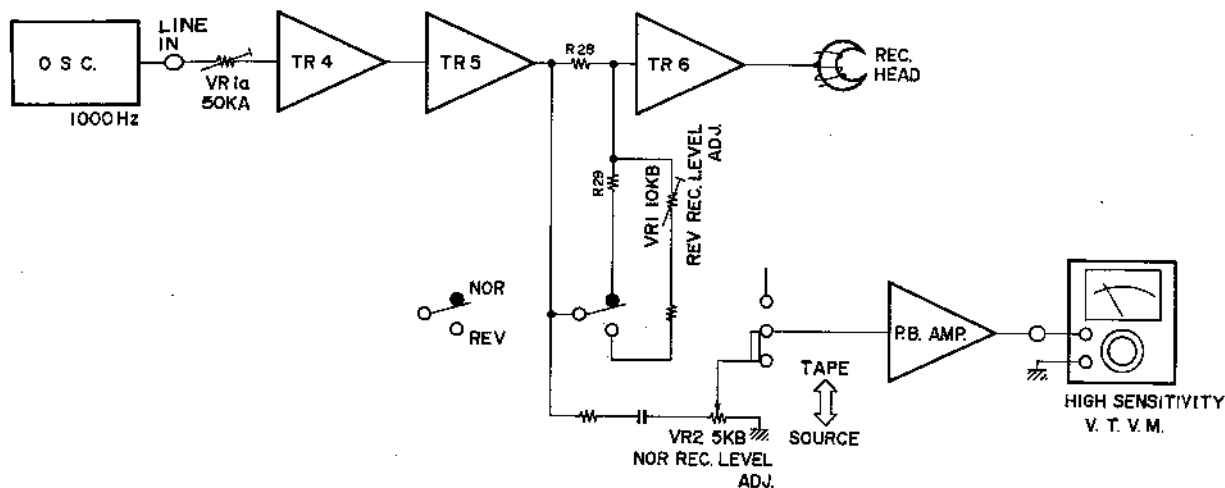


Fig. 18 REC. AMP. BLOCK DIAGRAM

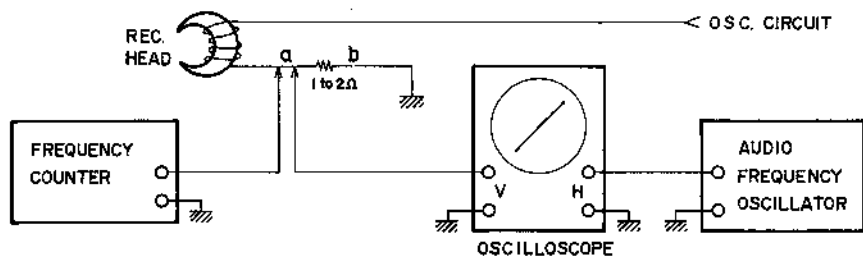


Fig. 19

### 3. RECORDING LEVEL ADJUSTMENT

(See Fig. 16)

- 1) Connect an Audio Frequency Oscillator to the line input and connect a High Sensitivity V.T.V.M. to the line output.
- 2) Set Tape Speed Selector to 7-1/2 ips.
- 3) Depress both LEFT and RIGHT Track Selector Switches.
- 4) Load an AKAI 100L (Fuji S-100) blank tape. Set the Monitor Switch to TAPE position and the Line Output Level Controls to maximum.
- 5) Set recorder to FWD recording mode and supply a 1,000 Hz sine wave signal to the line input from the Audio Frequency Oscillator. Adjust line recording level volume controls VR-1a and VR-1b (20k B) to obtain a line output level of 4 dB (0 VU) on both channels.
- 6) Set Monitor Switch to SOURCE position and adjust Monitor Switch P.C. Board (KH-5012) semi-fixed resistors VR-1 and VR-2 (5k B) to obtain a 4 dB line output level on both channels.
- 7) When the FWD recording level adjustment is completed, set the recorder to REV recording mode and set the Monitor Switch to TAPE position.
- 8) Adjust Rec. Amp P.C. Board (KH-5013) semi-fixed resistors VR-1 and VR-1b (10k B) to obtain a line output level of 4 dB on both channels.

### 4. RECORDING BIAS FREQUENCY

#### MEASURING METHOD AND ADJUSTMENT

##### Method I

- 1) Install a 1 to 2  $\Omega$  resistor in series with the recording head and connect these terminals (a)(b) to the vertical input of an oscilloscope. (See Fig. 19)
- 2) Supply a sine wave signal to the horizontal input of the Oscilloscope from an Audio Frequency Oscillator. Set recorder to the REC mode.
- 3) Vary the frequency of the Audio Frequency Oscillator until the oscilloscope waveform displays a circular or linear pattern.
- 4) If the audio frequency oscillator indication is  $103 \pm 5$  kHz, the recording bias frequency is correct.

##### Method II

- 1) Connect a Frequency Counter to points (a) and (b) as shown in Fig. 19. Set recorder to the REC mode, and take a frequency counter reading at this time.
- 2) If the Frequency Counter indication is  $103 \pm 5$  kHz, the recording bias frequency is correct.

##### Adjustment

The recording bias frequency can be adjusted by changing the value of OSC. circuit capacitor C-4 (4500P/500).

TAPE SPEED 3-3/4 ips

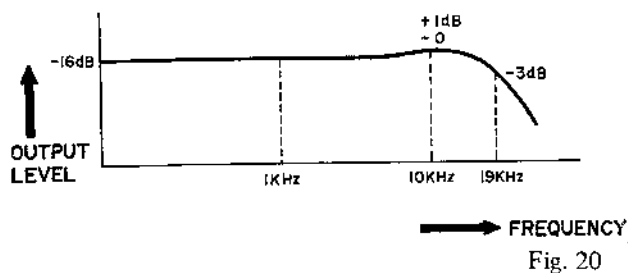


Fig. 20

## 5. RECORDING BIAS VOLTAGE ADJUSTMENT (Frequency Response Adjustment)

- 1) Refer to section regarding Frequency Response Measuring Method (Fig. 3 of this manual)
- 2) Adjust OSC. P.C. Board semi-fixed capacitors C-5 to C-8 (70P) so that a 10 kHz signal output level is within  $\pm 1/0$  dB in relation to 1,000 Hz. (See Figs. 16 & 17)
- 3) The bias voltage after the frequency response adjustment has been made is about 5V AC.

**NOTE:** The frequency response will vary depending upon the tape being used.

## 6. ERASE VOLTAGE

There is no way to adjust the erase voltage, but correct value is about 23V AC.

## 7. COMPUTE-O-MATIC RECORDING LEVEL SENSITIVITY ADJUSTMENT

- 1) Connect an Audio Frequency Oscillator to the left microphone input and connect a High Sensitivity V.T.V.M. to the left line output.
- 2) Supply a 1,000 Hz sine wave from the audio frequency oscillator.
- 3) Set the Monitor Switch to SOURCE position and depress both the LEFT and RIGHT Track Selector Switches.
- 4) Adjust COM-DET (Compute-O-Matic Detector) P.C. Board (RD-A514) semi-fixed resistor VR-201 (100k B) to obtain a 4 dB V.T.V.M. indication when the Compute-O-Matic Button is depressed.

## VII. TRANSPORT MECHANISM

### 1. TRANSISTOR, RELAY, AND PLUNGER SOLENOID OPERATION CHART

(Refer to Schematic Diagram 1 through 6)

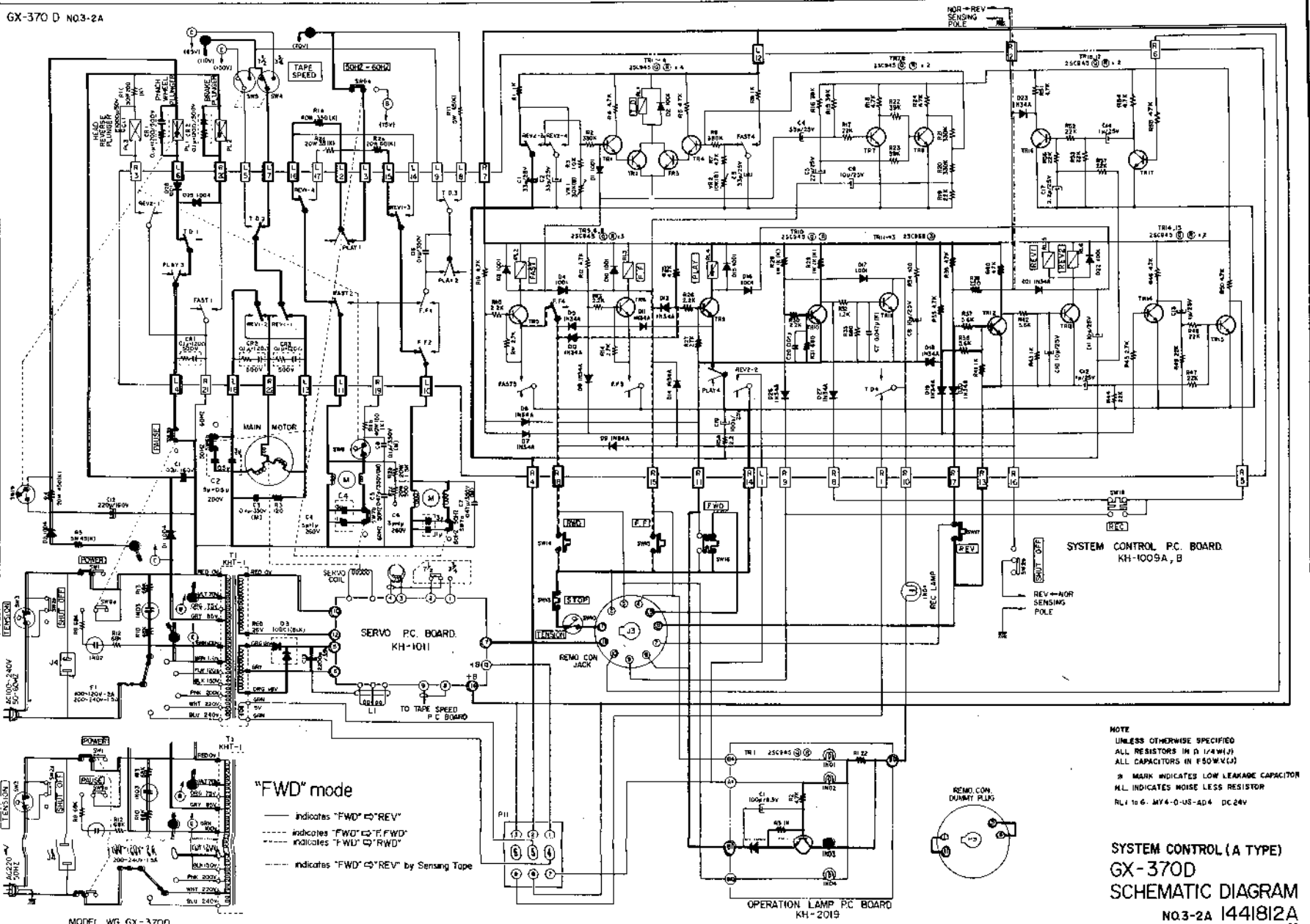
	FUNCTION	RWD	REV	STOP	FWD	F.FWD	FWD REC	REV REC
TRANSISTORS	TR1							
	TR2							
	TR3							
	TR4							
	TR5	○				○		
	TR6					○		
	TR7	○	○	○	○	○	○	○
	TR8	○	○	○	○	○	○	○
	TR9		○		○		○	○
	TR10	○	○	○	○	○		
	TR11						○	○
	TR12	○		○	○	○	○	○
	TR13			○				○
	TR14	○	○	○	○	○	○	○
	TR15						△	△
	TR16							
	TR17							
RELAYS	T.D RL1							
	FAST RL2	○				○		
	F.F RL3					○		
	PLAY RL4		○		○		○	○
	REV 1 RL5		○					○
	REV 2 RL6		○					○
PLUNGER SOLENOIDS	PINCH WHEEL PL1		○		○		○	○
	BRAKE PL2	○	○		○	○	○	○
	HEAD REV PL3		○					○

○ mark indicates "engaged"

△ mark indicates "momentarily engaged" when the REC, FWD or REV button is depressed

Chart 1



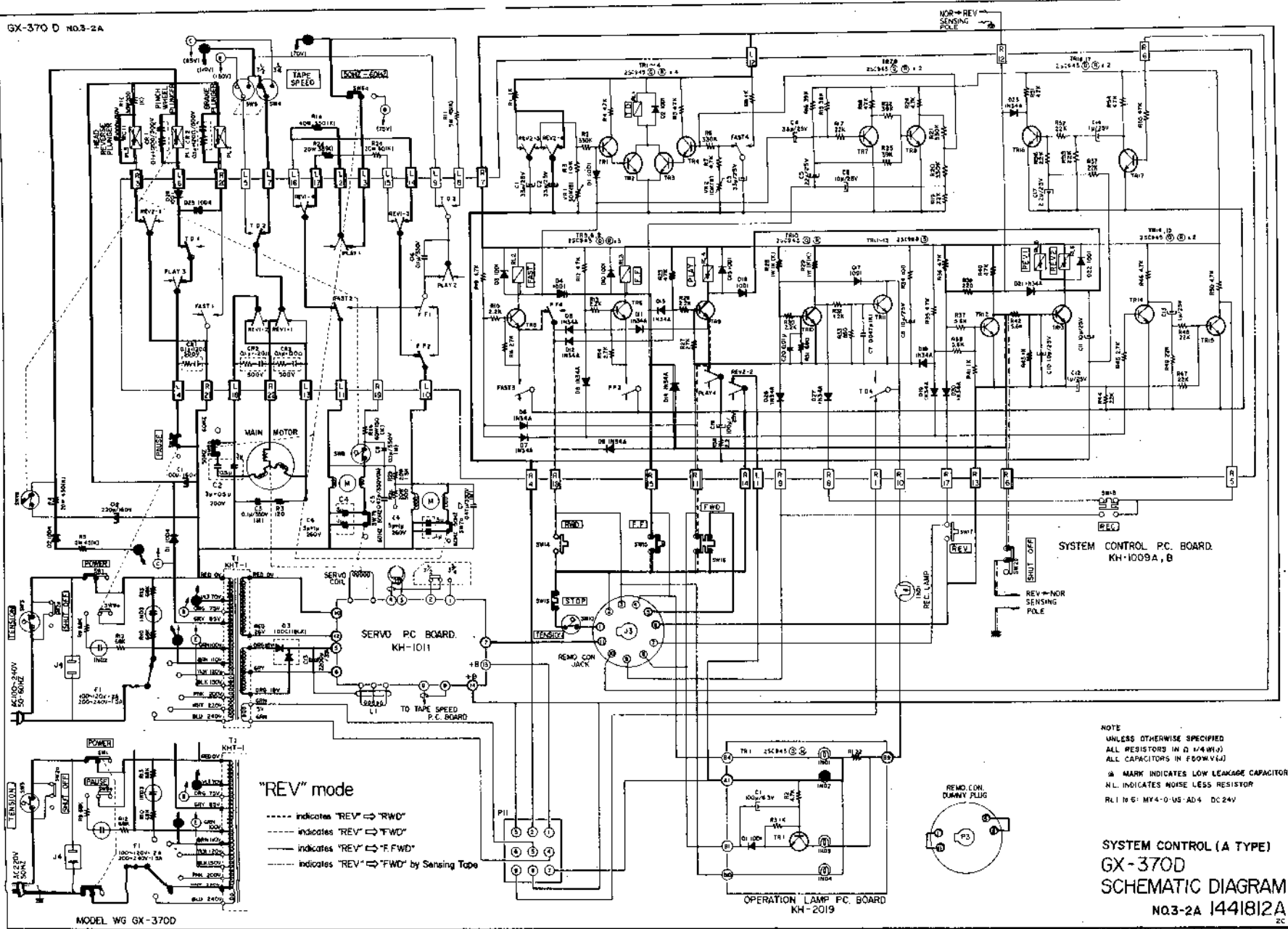


**"FWD" mode**

- indicates "FWD" to "REV"
- - - indicates "FWD" to "FWD"
- · · indicates "FWD" to "RWD"
- · - indicates "FWD" to "REV" by Sensing Tape

NOTE  
 UNLESS OTHERWISE SPECIFIED  
 ALL RESISTORS IN Ω (1/4W/1%)  
 ALL CAPACITORS IN F50M(V)  
 ▷ MARK INDICATES LOW LEAKAGE CAPACITOR  
 ML INDICATES NOISE LESS RESISTOR  
 RL1 to 6: MY4-0-US-AD4 DC 24V

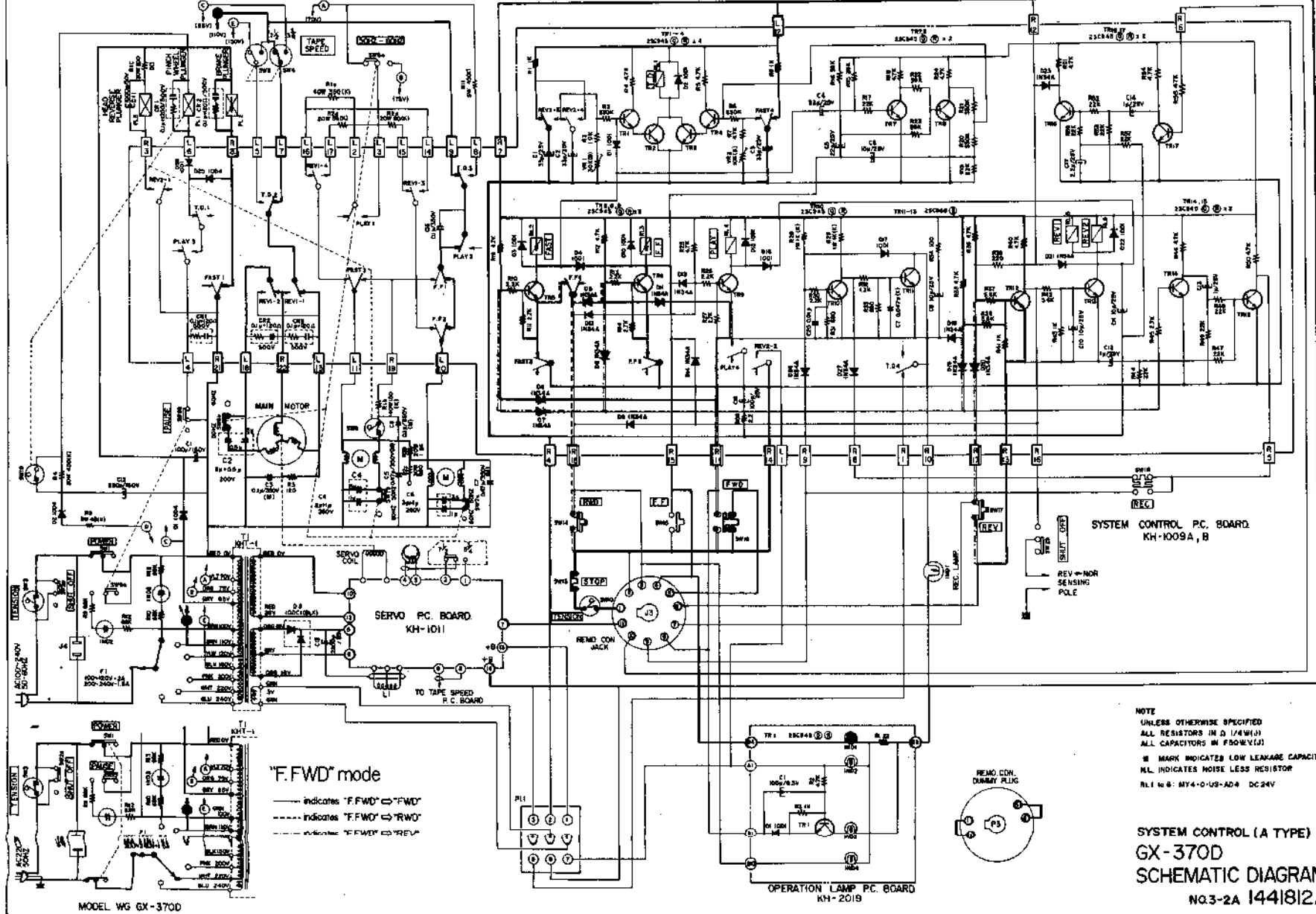
SYSTEM CONTROL (A TYPE)  
 GX-370D  
 SCHEMATIC DIAGRAM  
 NO3-2A 1441812A



NOTE  
UNLESS OTHERWISE SPECIFIED  
ALL RESISTORS IN Ω (4W/1/2)  
ALL CAPACITORS IN F (50V/1/2)  
\* MARK INDICATES LOW LEAKAGE CAPACITOR  
N.L. INDICATES NOISE LESS RESISTOR  
RL1 IN 6: MY4-0-US-AD4 DC 24V

SYSTEM CONTROL (A TYPE)  
GX-370D  
SCHEMATIC DIAGRAM  
NO.3-2A 1441812A

GX-370 D NO.3-2A



SYSTEM CONTROL P.C. BOARD  
KH-1009A, B

SERVO P.C. BOARD  
KH-1011

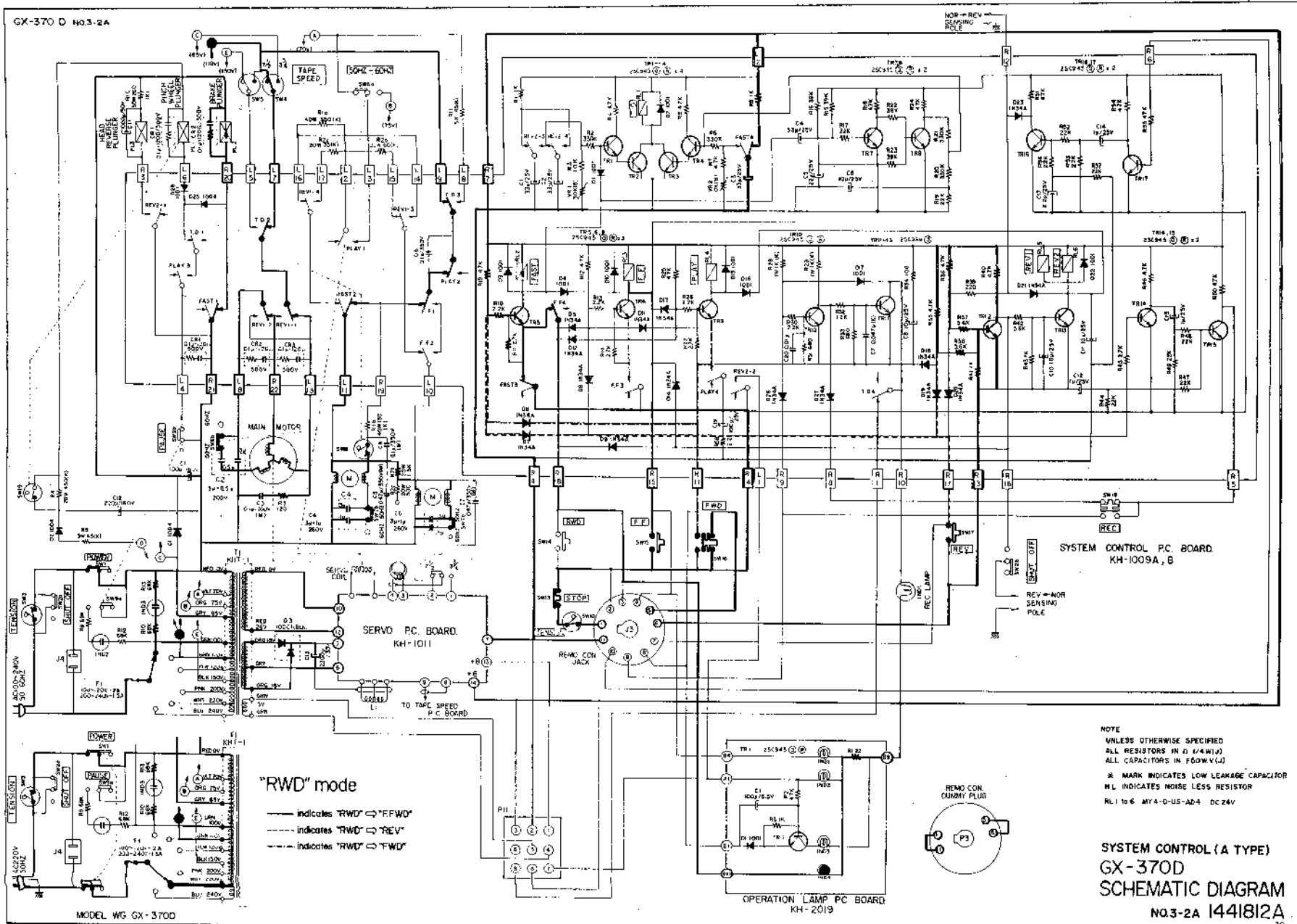
OPERATION LAMP P.C. BOARD  
KH-2019

NOTE  
UNLESS OTHERWISE SPECIFIED  
ALL RESISTORS IN Ω (1/4W)(1)  
ALL CAPACITORS IN PPMV(L1)  
M MARK INDICATES LOW LEAKAGE CAPACITOR  
ML INDICATES NOISE LESS RESISTOR  
RL1 NO 6: NY4-0-US-AD-4 DC24V

SYSTEM CONTROL (A TYPE)  
GX-370D  
SCHEMATIC DIAGRAM  
NO.3-2A 144182A  
2C

MODEL WG GX-370D

GX-370 D NO.3-2A



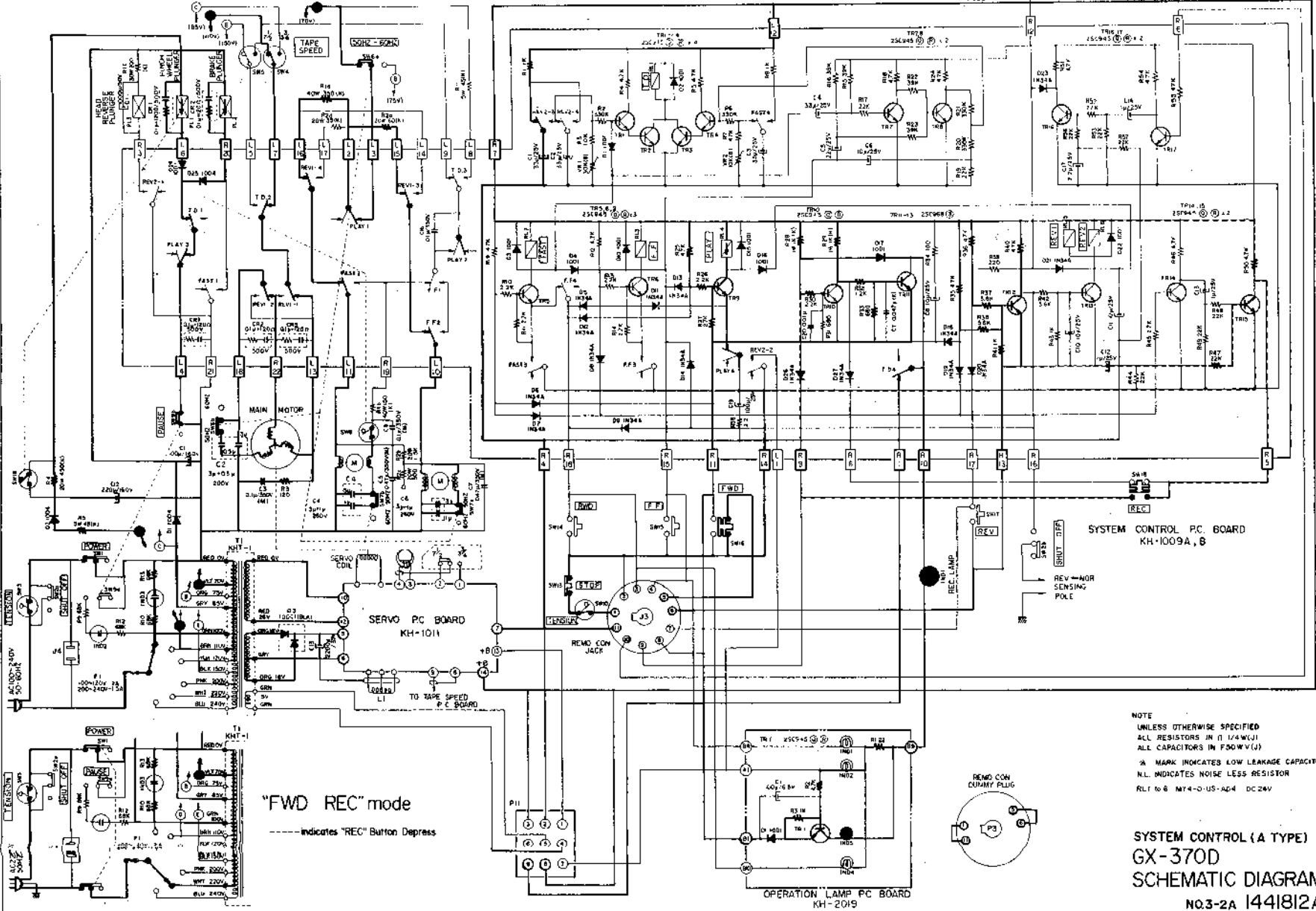
"RWD" mode

- indicates "RWD" → "FFWD"
- - - indicates "RWD" → "REV"
- · · indicates "RWD" → "FWD"

NOTE  
 UNLESS OTHERWISE SPECIFIED  
 ALL RESISTORS IN Ω (4W/1/2)  
 ALL CAPACITORS IN 500V(V/L)  
 \* MARK INDICATES LOW LEAKAGE CAPACITOR  
 ML INDICATES NOISE LESS RESISTOR  
 RL1 to 6 MY4-G-US-AD4 DC24V

SYSTEM CONTROL (A TYPE)  
 GX-370D  
 SCHEMATIC DIAGRAM  
 NO.3-2A 1441812A  
 20

MODEL WG GX-370D

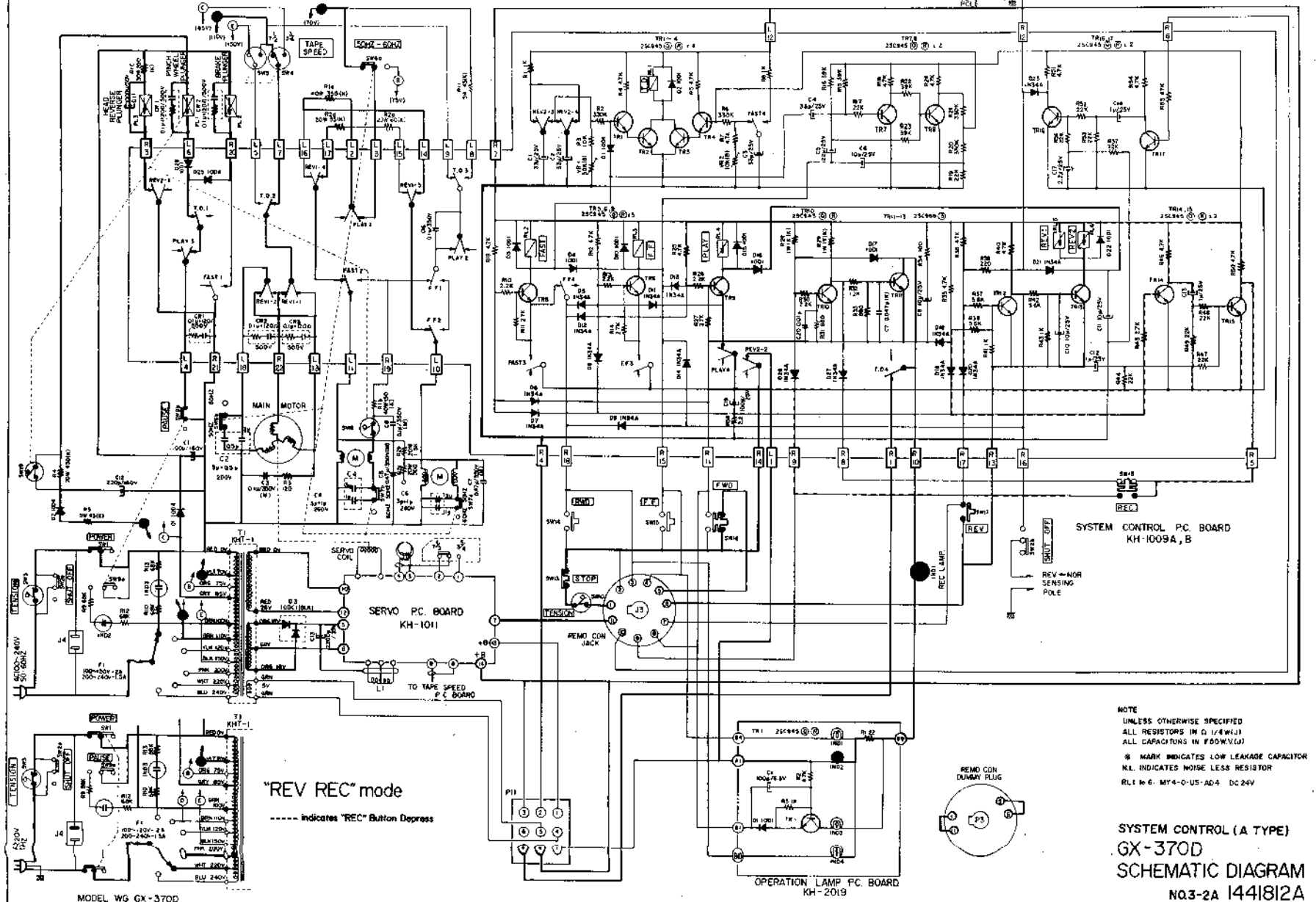


"FWD REC" mode  
 - - - - - indicates "REC" Button Depress

NOTE  
 UNLESS OTHERWISE SPECIFIED  
 ALL RESISTORS IN (1/4 WATT)  
 ALL CAPACITORS IN (F50WV(U))  
 \* MARK INDICATES LOW LEAKAGE CAPACITOR  
 NL INDICATES NOISE LESS RESISTOR  
 RL1 to 8 M74-0-US-AP4 DC24V

SYSTEM CONTROL (A TYPE)  
 GX-370D  
 SCHEMATIC DIAGRAM  
 NO.3-2A 1441812A

GX-370 D NO 3-2A



SYSTEM CONTROL P.C. BOARD KH-1009A, B

SERVO P.C. BOARD KH-1011

OPERATION LAMP P.C. BOARD KH-2019

NOTE  
 UNLESS OTHERWISE SPECIFIED  
 ALL RESISTORS IN Ω (4-W/Ω)  
 ALL CAPACITORS IN µF (5-W/µF)  
 \* MARK INDICATES LOW LEAKAGE CAPACITOR  
 N.L. INDICATES NOISE LESS RESISTOR  
 RL1 to 6: MY4-O-US-A04 DC 24V

SYSTEM CONTROL (A TYPE)  
 GX-370D  
 SCHEMATIC DIAGRAM  
 NO3-2A 1441812A

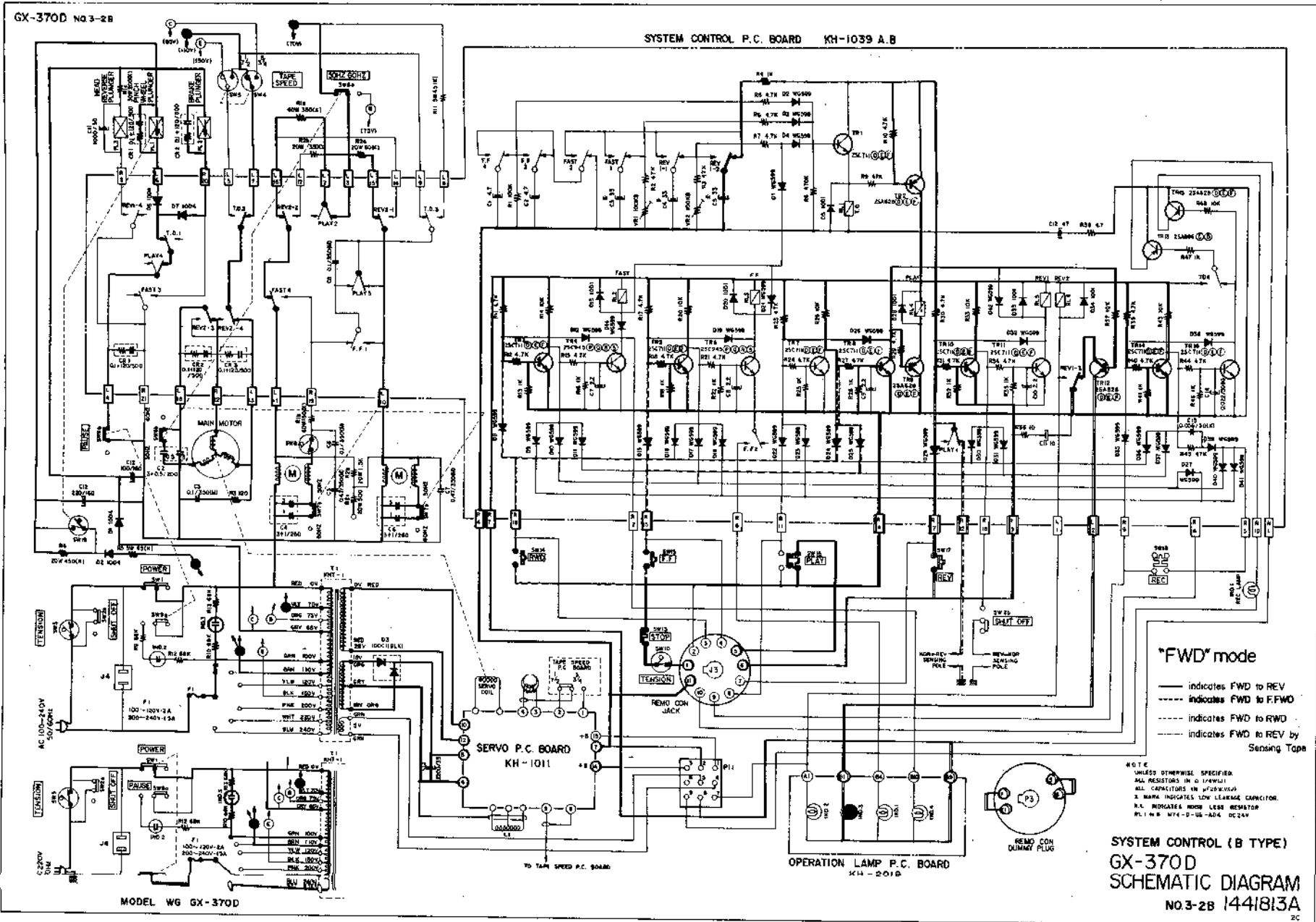
MODEL WG GX-370D

(Refer to Schematic Diagram 7 through 12)

	FUNCTION	RWD	REV	STOP	FWD	F.FWD	FWD REC	REV REC
TRANSISTORS	TR1							
	TR2		○		○		○	○
	TR3		○	○	○	○	○	○
	TR4	○						
	TR5	○	○	○	○		○	○
	TR6					○		
	TR7	○		○		○		
	TR8		○		○		○	○
	TR9		○		○		○	○
	TR10	○		○	○	○	○	
	TR11		○					○
	TR12					○	○	
	TR13						○	○
	TR14	○	○	○	○	○		
	TR15						○	○
	TR16						○	○
RELAYS	T.D RL1							
	FAST RL2	○				○		
	F.F RL3					○		
	PLAY RL4		○		○		○	○
	REV1 RL5		○					○
	REV2 RL6		○					○
PLUNGER SOLENOIDS	PINCH WHEEL PL1		○		○		○	○
	BRAKE PL2	○	○		○	○	○	○
	HEAD REV PL3		○					○

○ mark indicates "engaged"

Chart 2



GX-370D NO.3-2B

SYSTEM CONTROL P.C. BOARD KH-1039 A.B

\*FWD\* mode

- indicates FWD to REV
- - - indicates FWD to F.FWD
- · · indicates FWD to RWD
- · · indicates FWD to REV by Sensing Tape

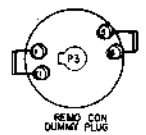
NOTE  
 UNLESS OTHERWISE SPECIFIED  
 ALL RESISTORS IN Ω (1/4W/1)  
 ALL CAPACITORS IN μF(250V)  
 X MARK INDICATES LOW LEAKAGE CAPACITOR  
 N.L. INDICATES NON-LEAK RESISTOR  
 M.I. N.B. NY4-D-US-ADA DC24V

SYSTEM CONTROL (B TYPE)  
 GX-370D  
 SCHEMATIC DIAGRAM  
 NO.3-2B 144/813A  
 2C

MODEL WG GX-370D

TO TAPE SPEED P.C. BOARD

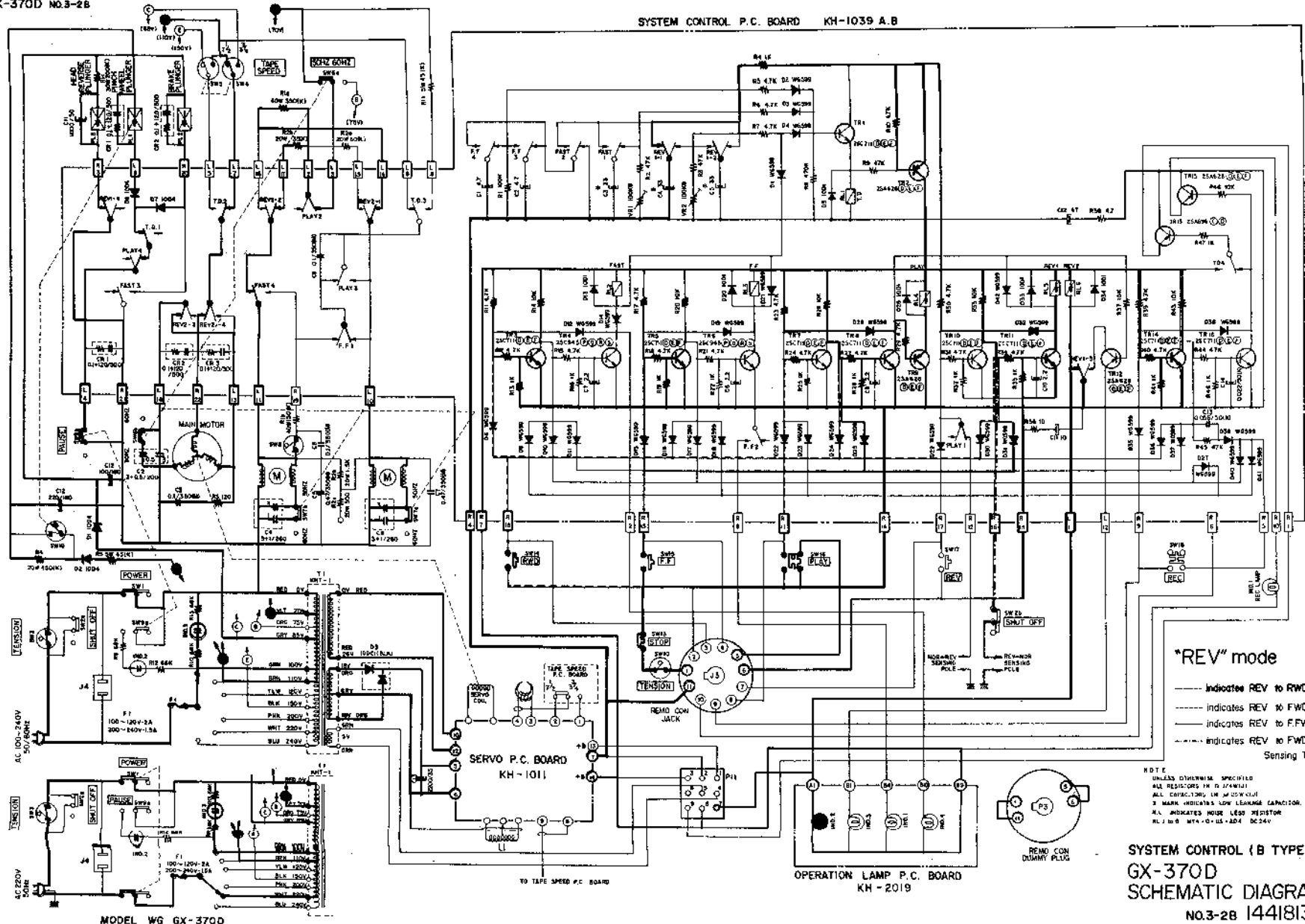
OPERATION LAMP P.C. BOARD KH-2019





GX-370D No.3-2B

SYSTEM CONTROL P.C. BOARD KH-1039 A.B

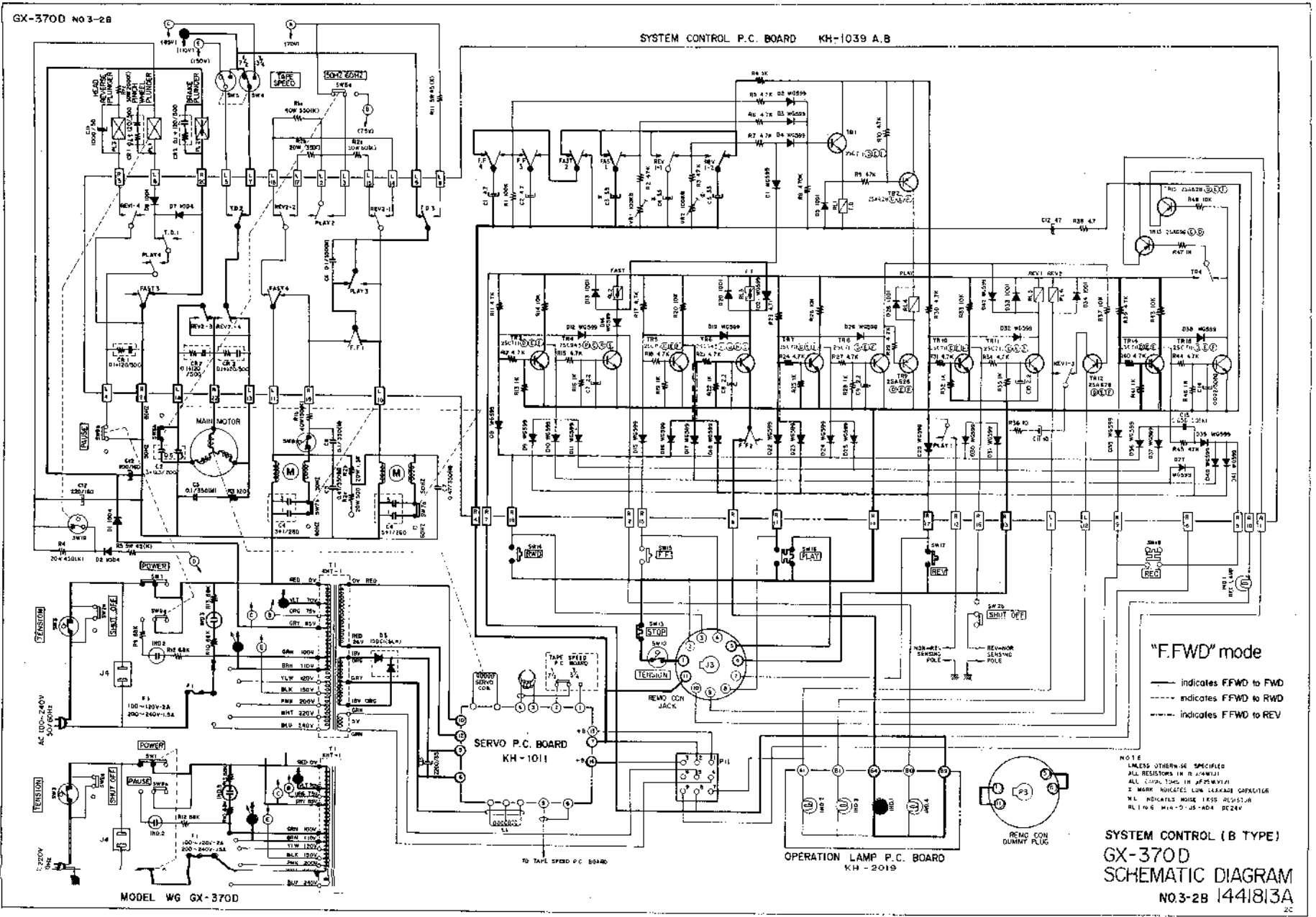


\*REV\* mode

- indicates REV to RWD
- - - indicates REV to FWD
- indicates REV to F.FWD
- - - indicates REV to FWD by Sensing Tape

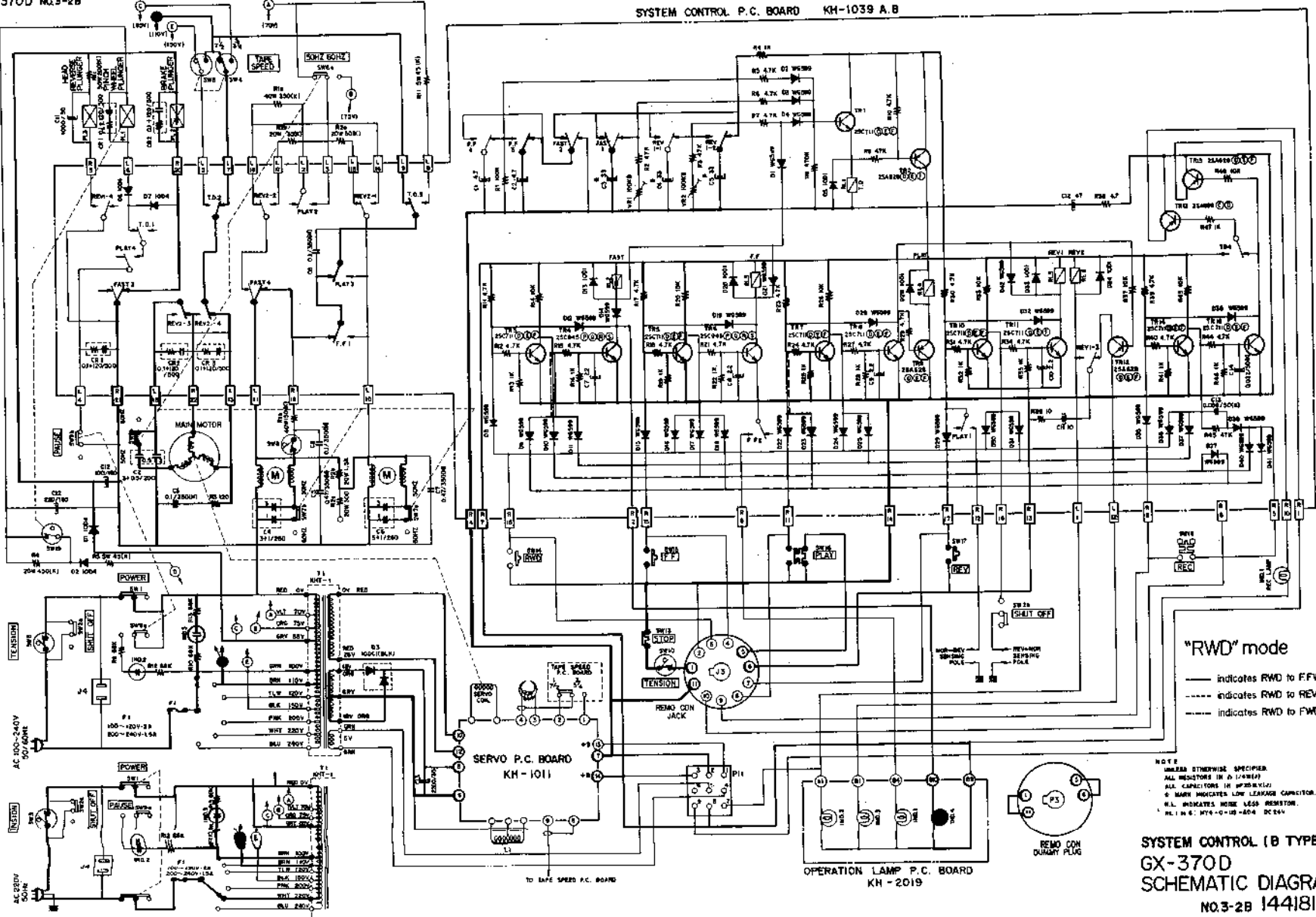
NOTE  
 UNLESS OTHERWISE SPECIFIED  
 ALL RESISTORS IN Ω (K=KΩ)  
 ALL CAPACITORS IN μ (M=μF)  
 3 MARK INDICATES LOW LEAKAGE CAPACITOR  
 M.I. INDICATES NOISE LESS RESISTOR  
 RLJ 108 MTA-G-15-A04 DC24V

SYSTEM CONTROL (B TYPE)  
 GX-370D  
 SCHEMATIC DIAGRAM  
 No.3-2B 1441813A



GX-370D NO.3-2B

SYSTEM CONTROL P.C. BOARD KH-1039 A.B



"RWD" mode

- indicates RWD to FFW
- - - indicates RWD to REV
- · · indicates RWD to FWD

NOTE  
 UNLESS OTHERWISE SPECIFIED  
 ALL INDUCTORS IN μ (MICRO)  
 ALL CAPACITORS IN μF (MICROFARAD)  
 ○ MARK INDICATES LOW LEAKAGE CAPACITOR.  
 M.L. INDICATES MORE LESS RESISTOR.  
 M.L.I.N.S. 874-0-10-104-DC-54V

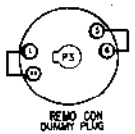
SYSTEM CONTROL (B TYPE)  
 GX-370D  
 SCHEMATIC DIAGRAM  
 NO.3-2B 144183A

MODEL WG GX-370D

OPERATION LAMP P.C. BOARD KH-2019

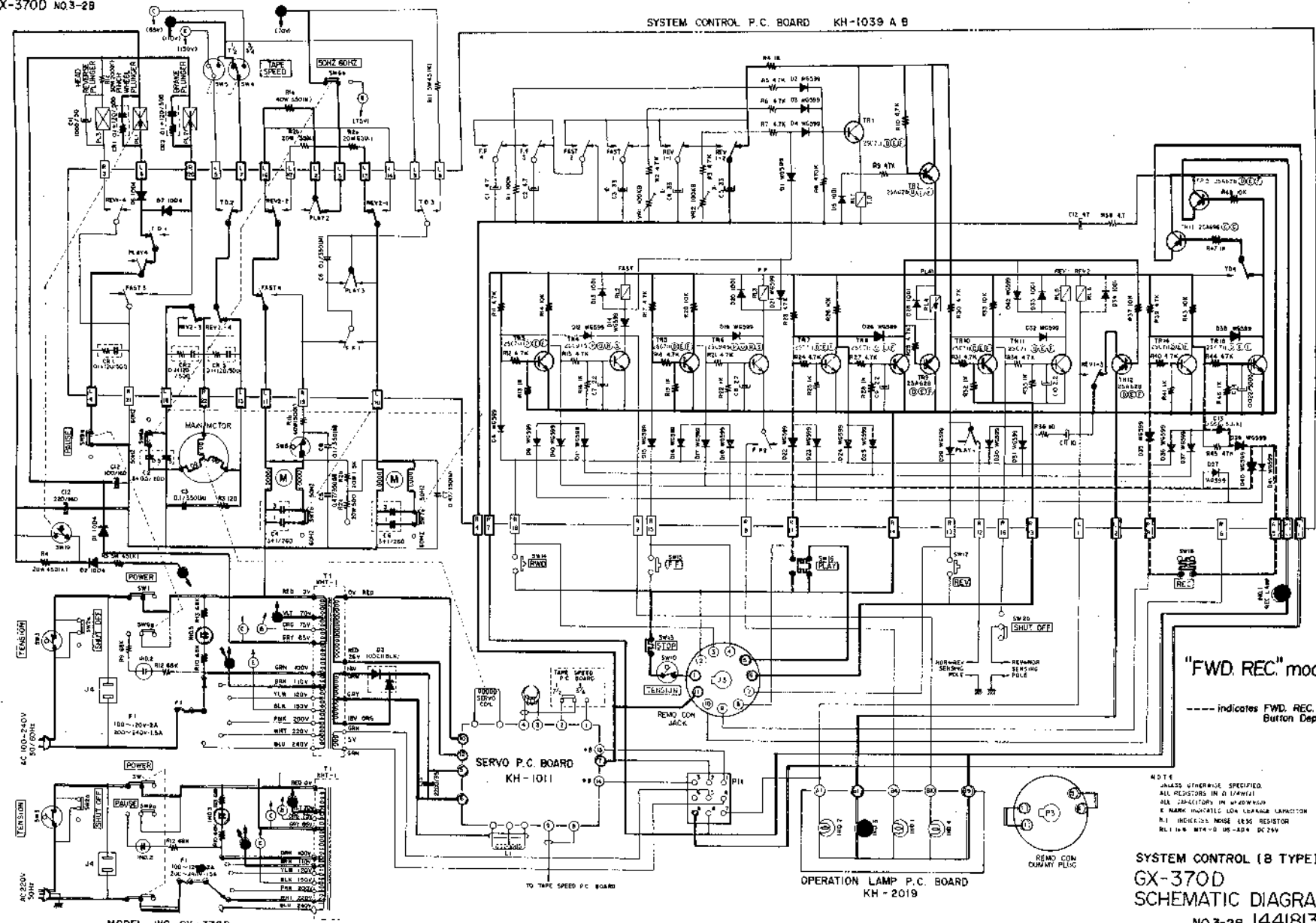
SERVO P.C. BOARD KH-1011

TO SAFE SPEED P.C. BOARD



GX-370D NO.3-28

SYSTEM CONTROL P.C. BOARD KH-1039 A B



"FWD. REC." mode  
 --- indicates FWD. REC. Button Depress

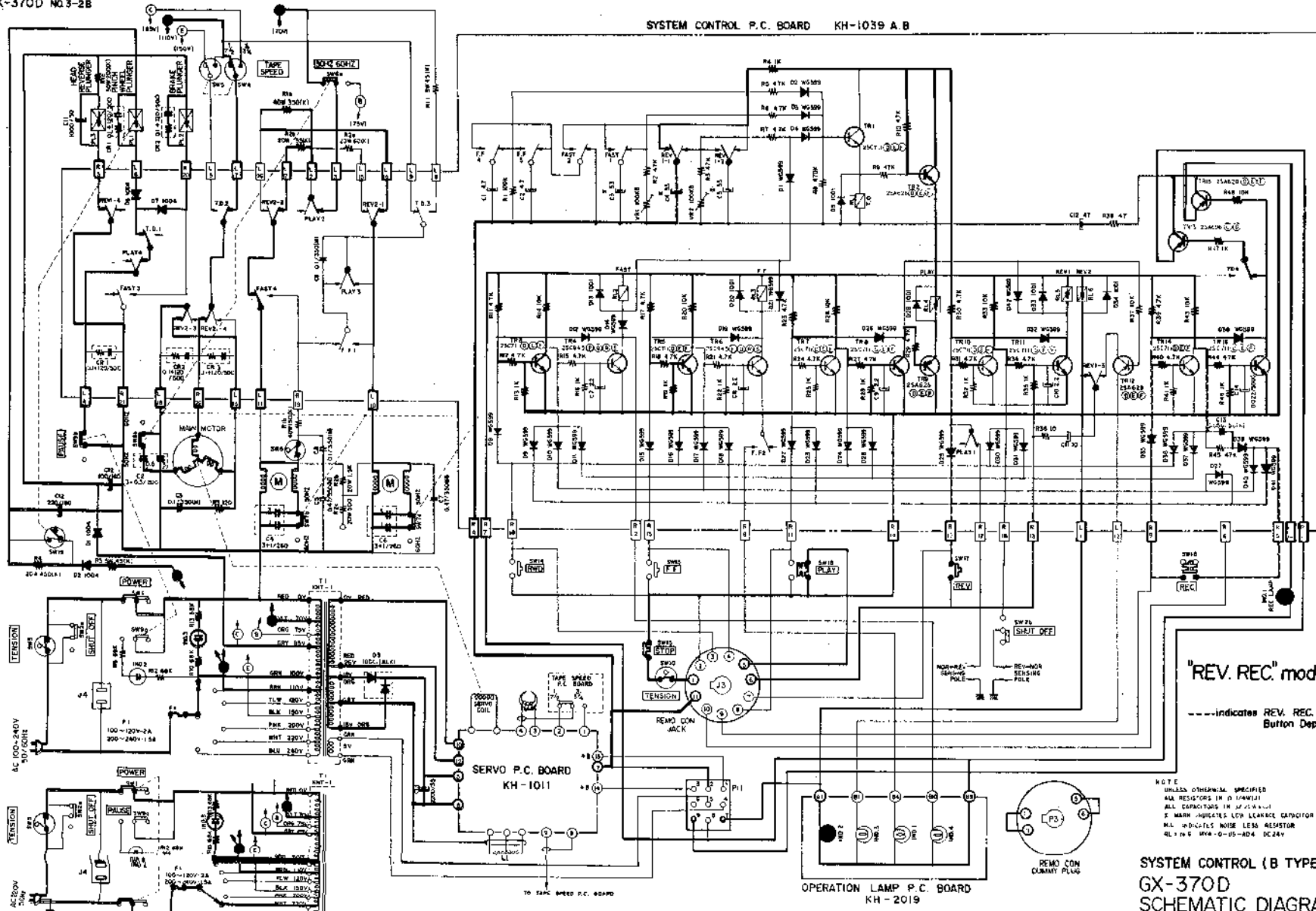
NOTE  
 UNLESS OTHERWISE SPECIFIED  
 ALL RESISTORS IN Ω (OHMS)  
 ALL CAPACITORS IN μF (MICRO)  
 E MARK INDICATES LOW LEAKAGE CAPACITOR  
 RL1 INDICATES NOISE LESS RESISTOR  
 RL11 THROUGH RL14 ARE 1/4W 0.1% DC 25V

SYSTEM CONTROL (B TYPE)  
 GX-370D  
 SCHEMATIC DIAGRAM  
 NO.3-28 1441813A  
 2C

MODEL WG GX-370D

GX-370D NO.3-2B

SYSTEM CONTROL P.C. BOARD KH-1039 A B



"REV. REC." mode

--- indicates REV. REC. Button Depress

NOTE  
UNLESS OTHERWISE SPECIFIED  
ALL RESISTORS IN OHMS  
ALL CAPACITORS IN MICROFARADS  
C MARK INDICATES LOW LEAKAGE CAPACITOR  
ML INDICATES NOISE LESS RESISTOR  
RL IN G. WVA-G-US-AD4 DC24V

SYSTEM CONTROL (B TYPE)  
GX-370D  
SCHEMATIC DIAGRAM  
NO.3-2B 1441813A

MODEL WG GX-370D

OPERATION LAMP P.C. BOARD  
KH-2019

SERVO P.C. BOARD  
KH-1011

TO TAP SPEED P.C. BOARD

REMO CON COUNTRY PLUG

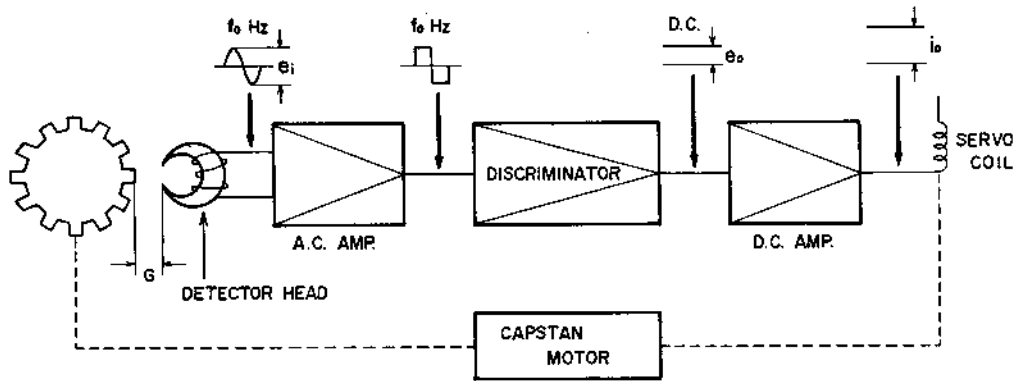
**2. VOLTAGE SUPPLY TO TORQUE MOTOR  
AND TENSION AT VARIOUS MODES**

TORQUE MOTOR MODE	Left Side	Right Side
FWD	29V (35V) 50g	55V (62V) 170g
REV	61V (67V) 210g	29V (35V) 50g
F.FWD	10V (10V) 15g	118V (118V) 600g
RWD	118V (118V) 600g	10V (10V) 15g

( ) indicates Voltage at 60 Hz.

Chart 3

## VIII. SERVO MOTOR OPERATING PRINCIPLES



G (Gap): Adjust to obtain a detector head terminal voltage of  $3 \pm 0.5$  mV at 7-1/2 ips.

Fig. 21

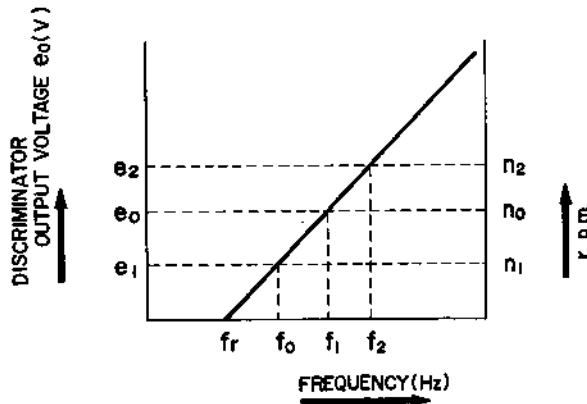


Fig. 22

1. The detector head core is comprised of a permanent magnet, and the gear installed on the motor, by means of the capstan motor revolutions, changes the magnetic flux of the detector head core. Accordingly, the detector head coil works in the same way and generates AC Voltage (becomes the detector signal described below). When this detector signal voltage ( $e_i$ ) becomes detector signal frequency ( $f_0$ ), this adjusts the capstan motor revolutions proportionately. (See Figs. 21 & 22)
2. When the detector signal voltage generated from the detector head is about 3 mV (at 7-1/2 ips), because the level is low, the perpendicular (up and down) waveform is amplified by the AC Amplifier until the waveform is clipped. (See Fig. 21)

3. Discriminator Coil L-1 (V12031SC-01) and C-210 (0.051/50) at 7-1/2 ips (and C-211 (0.27/100) at 3-3/4 ips) constitute the resonance circuit, and this resonance frequency becomes  $f_r$ . Because the detector signal frequency generated at the detector coil differs according to capstan motor revolutions, the capacity of the discriminator resonance condenser changes, and the resonance frequency changes at the different tape speeds of 7-1/2 and 3-3/4 ips.

4. When the discriminator input frequency and the resonance frequency  $f_r$  are simultaneous, the DC signal to be supplied to the next stage DC Amplifier is not generated. Consequently, when the capstan motor rotates at normal speed, a higher than resonance frequency  $f_r$ , detector signal. Signal frequency  $f_0$  is established.
5. As shown in Chart 4, when electric current is not flowing to the capstan motor servo coil, the capstan motor revolutions are far faster than normal revolutions. Consequently, in order to maintain normal revolutions, an electro-magnetic field is generated at the servo coil by means of collector current flowing to TR-209 (2SD234), and this serves as an electro-magnetic brake. This electro-magnetic brake and the load torque balances the capstan motor torque and normal revolutions are maintained.

TAPE SPEED	Capstan motor supply voltage	Capstan motor supply voltage at FWD or REV starting time	Voltage and frequency generated at the detector coil	Controlled capstan motor speed	Uncontrolled capstan motor speed
7-1/2 ips	110V	150V	$3 \text{ mV} \pm 0.5 \text{ mV}$ r.m.s. / 1040 Hz	520 r.p.m.	1420 r.p.m.
3-3/4 ips	85V	110V	$1.5 \text{ mV} \pm 0.25 \text{ mV}$ r.m.s. / 520 Hz	260 r.p.m.	1380 r.p.m.

Chart 4

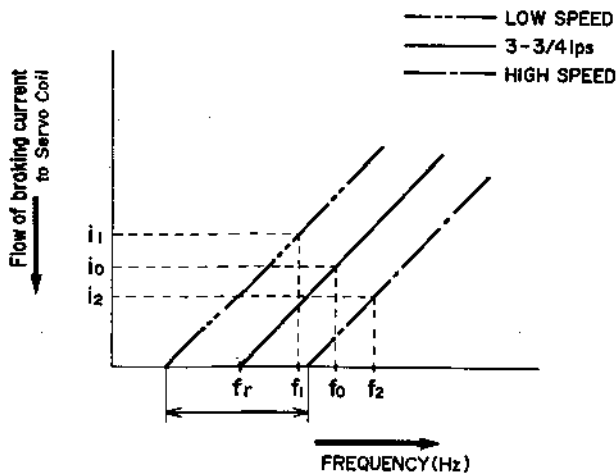


Fig. 23

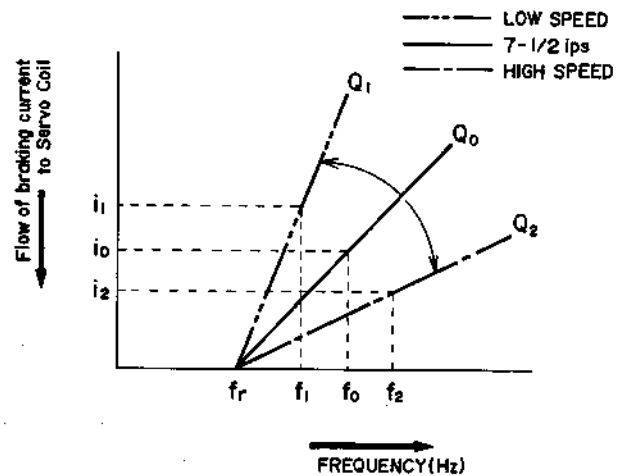


Fig. 24

6. In case of the capstan motor revolutions having reached the speed of  $n_2$ , the detector signal produced at the detector coil surpasses  $f_0$  and advances toward the higher  $f_2$  frequency. (See Figs. 23 & 24). Accordingly, the flow of current to the servo coil increases, and because the electro-magnetic braking supplied to the capstan motor is increased, the capstan motor revolutions become slower, and normal revolutions are regained.
7. In case of the capstan motor revolutions having slowed to  $n_1$ , the detector signal produced at the detector coil drops to lower than  $f_0$  and descends toward the low  $f_1$  frequency (See Figs. 23 & 24). Accordingly, the flow of current to the servo coil decreases, and because the electro-magnetic braking supplied to the capstan motor is decreased, the capstan motor revolutions speed up and normal revolutions are regained.

8. To obtain the proper number of revolutions, adjustment of the flow of brake current to the servo coil is necessary.

- 1) At 3-3/4 ips tape speed

As shown in Fig. 23, resonance frequency  $f_r$  (between the arrow mark) is changed by adjusting the dust core of discriminator coil L-1 (V1203 1SC-01). Accordingly,  $f_0$  is also changed between  $f_1$  and  $f_2$ , and the flow of braking current ( $i_0$ ) to the servo coil is also changed between  $i_1$  and  $i_2$ . Consequently, correct tape speed can be attained by using a tape speed measuring tape and a Frequency Counter and adjusting the dust core of coil L-1.

- 2) At 7-1/2 ips tape speed

As shown in Fig. 24,  $Q_0$  of the resonance circuit (within the arrow mark with  $f_r$  as center frequency), is changed by adjusting discriminator semi-fixed resistor VR-202 (2k B). Therefore,  $f_0$  is also changed between  $f_1$  and  $f_2$ , and the flow of current ( $i_0$ ) to the servo coil is also changed between  $i_1$  and  $i_2$ . Consequently, correct tape speed can be attained by using a tape speed measuring tape and a Frequency Counter and adjusting semi-fixed resistor VR-202.



## IX. DIFFERENTIATION OF SYSTEM CONTROL SCHEMATIC DIAGRAM & P. C. BOARD

---

1. Because the System Control Schematic Diagram and the P.C. Board are differentiated by serial number, the following (Chart 5) is provided for reference.

Serial Number	Schematic Diagram No.	P.C. Board
# 70301-0001 to # 70809-2000	No. 3-3A	KH-1009A, B
from # 71011-0001	No. 3-3B	KH-1039A, B

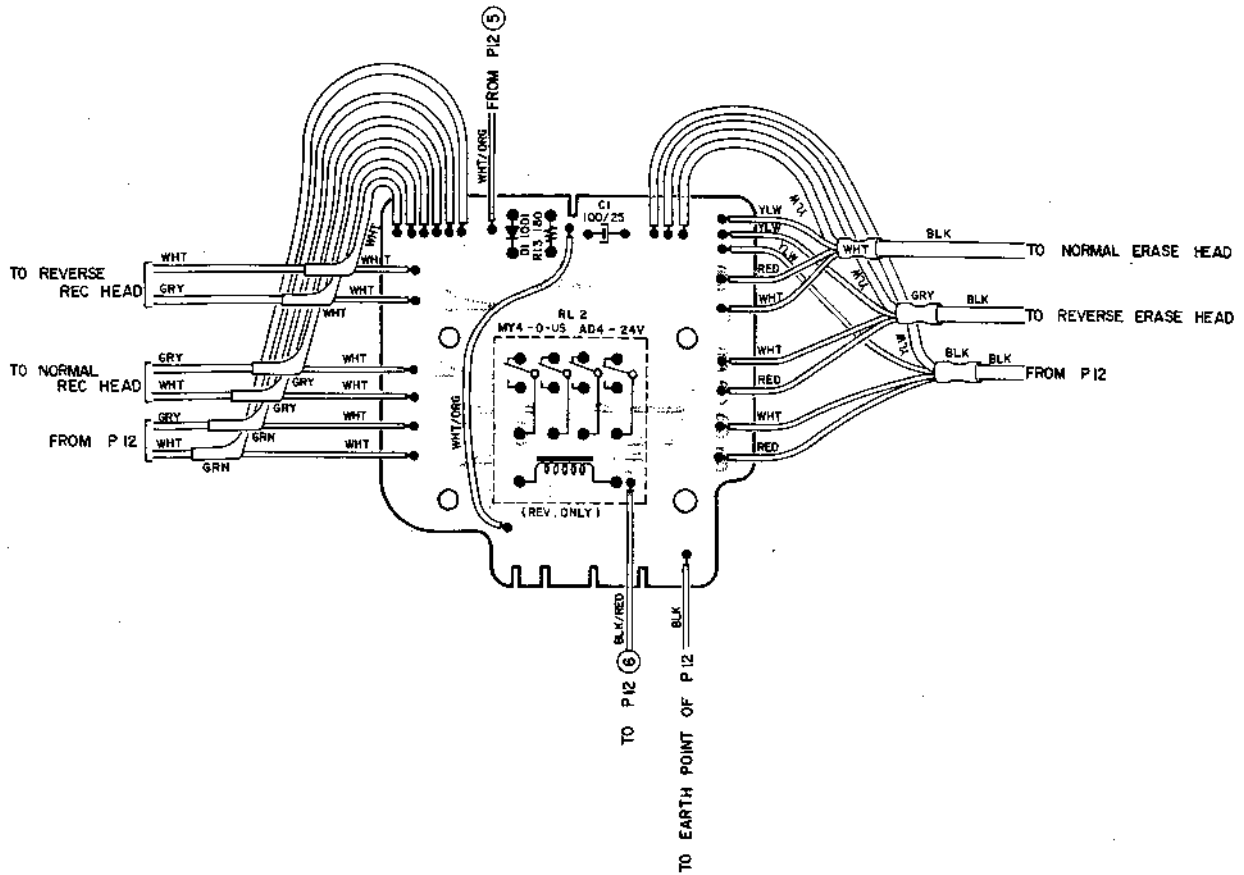
Chart 5

Accordingly, because System Control P.C. Board KH-1009A, B and KH-1039A, B are not interchangeable, when placing your order, be sure to state the System Control P.C. Board number.

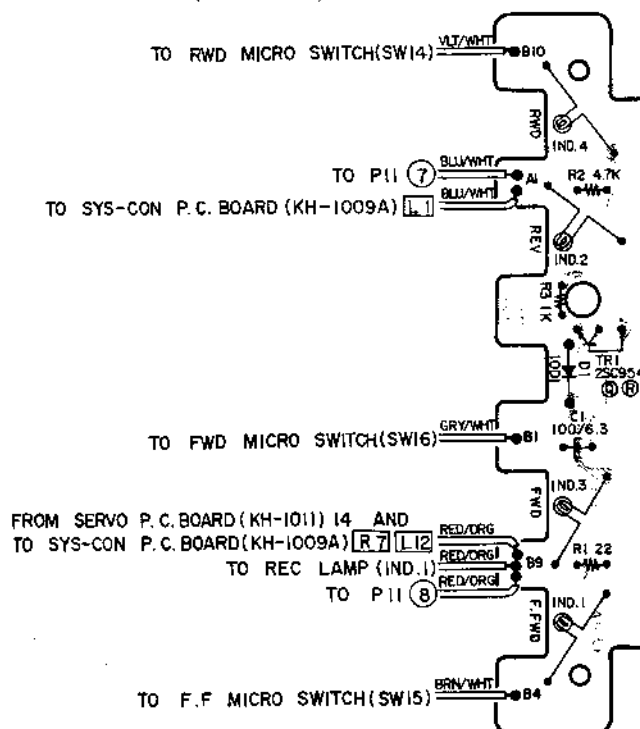
2. When using a KH-1039A, B in a machine employing System Control P.C. Board KH-1009A, B, the following changes are also necessary.
- 1) Remove the lead wires connected to operation switches SW-14 (RWD), SW-15 (F.FWD), and SW-16 (FWD) from terminals (B1) (B4) and (B10) of the Operation Lamp P.C. Board.
  - 2) Remove the multi-socket terminal [L12] lead wire connected to the System Control P.C. Board, and connect terminals [L12] and (B1).
  - 3) Remove the multi-socket terminal [R8] lead wire connected to the System Control P.C. Board, and connect terminals [R8] and (B4).
  - 4) Remove the multi-socket terminal [R2] lead wire and connect terminals [R2] and (B10).
  - 5) Disconnect the various inner components (resistor, capacitor, diode, and transistor) of the Operation Lamp P.C. Board and directly connect Lamps IND-1 through IND-4.

# X. COMPOSITE VIEWS OF COMPONENTS

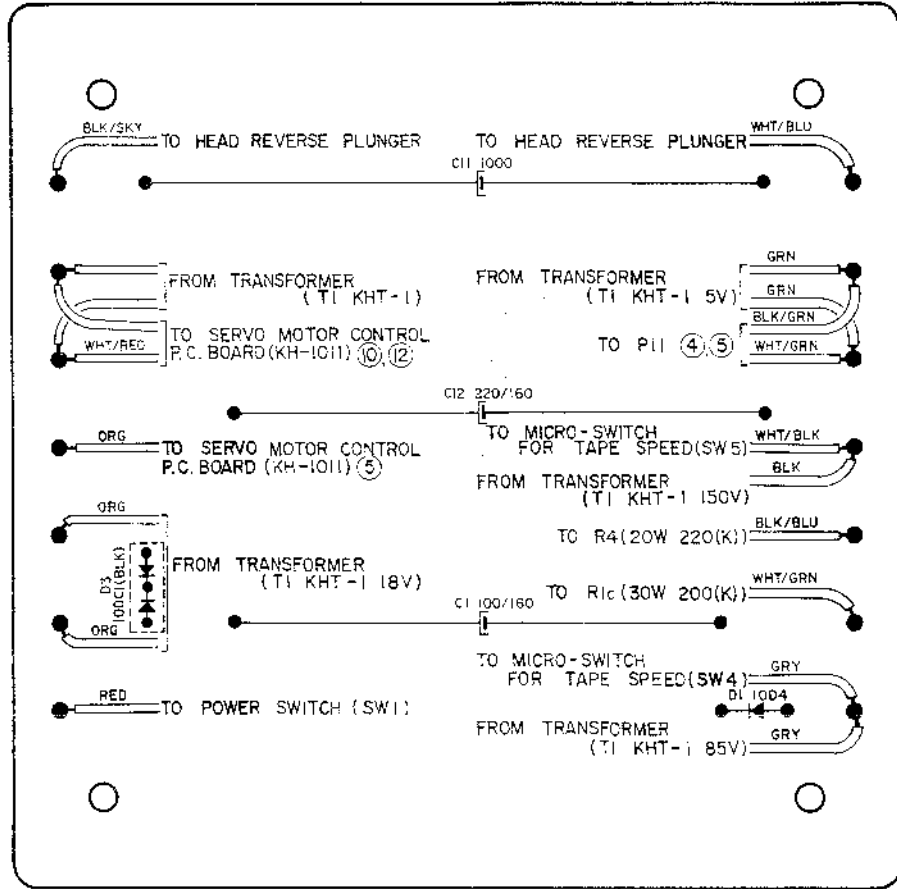
## HEAD RELAY P.C. BOARD (KH-0029)



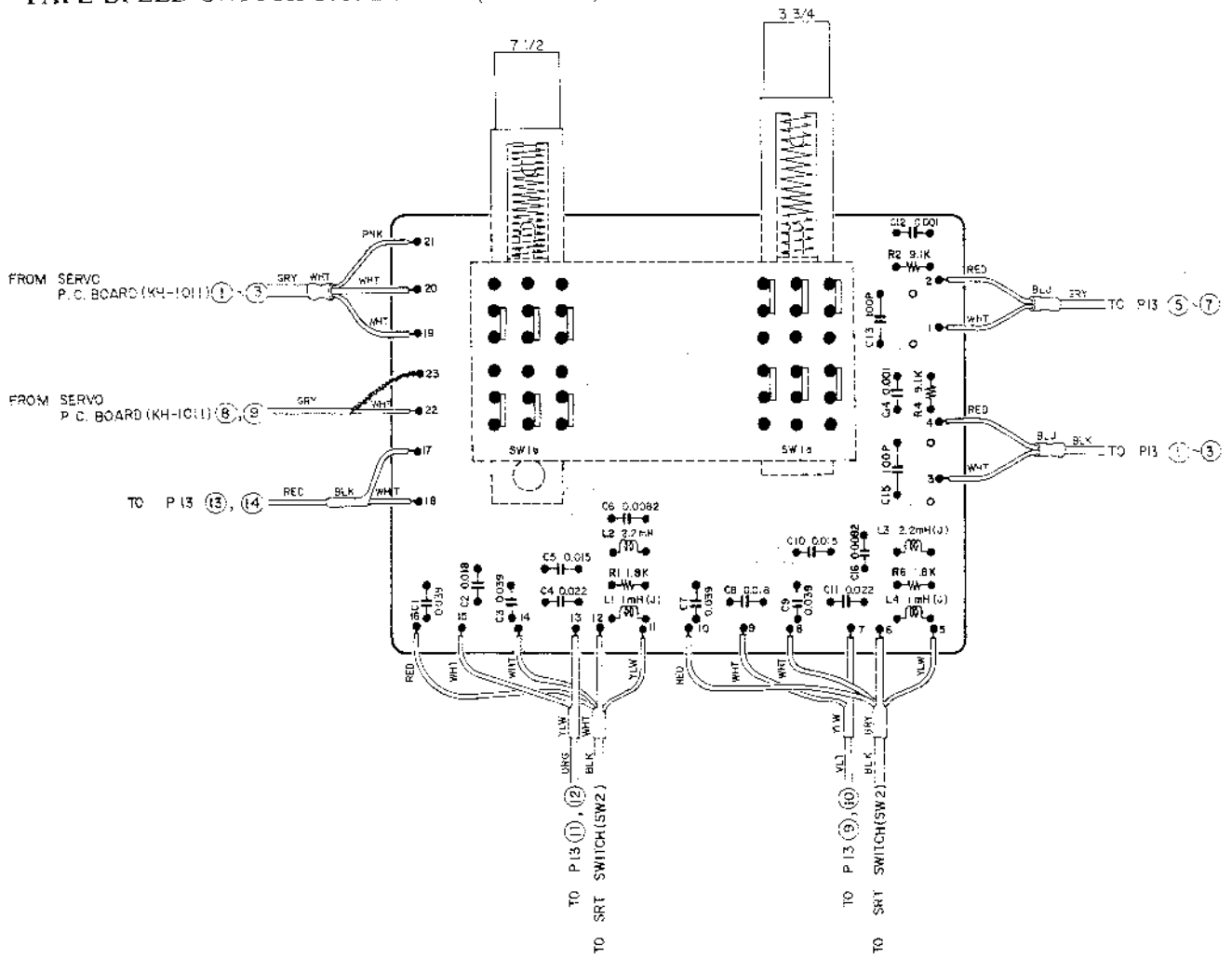
## OPERATION LAMP P.C. BOARD (KH-2019)



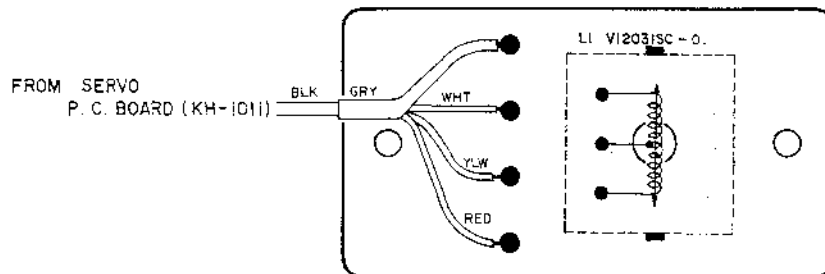
CAPACITOR P.C. BOARD (KH-2012)



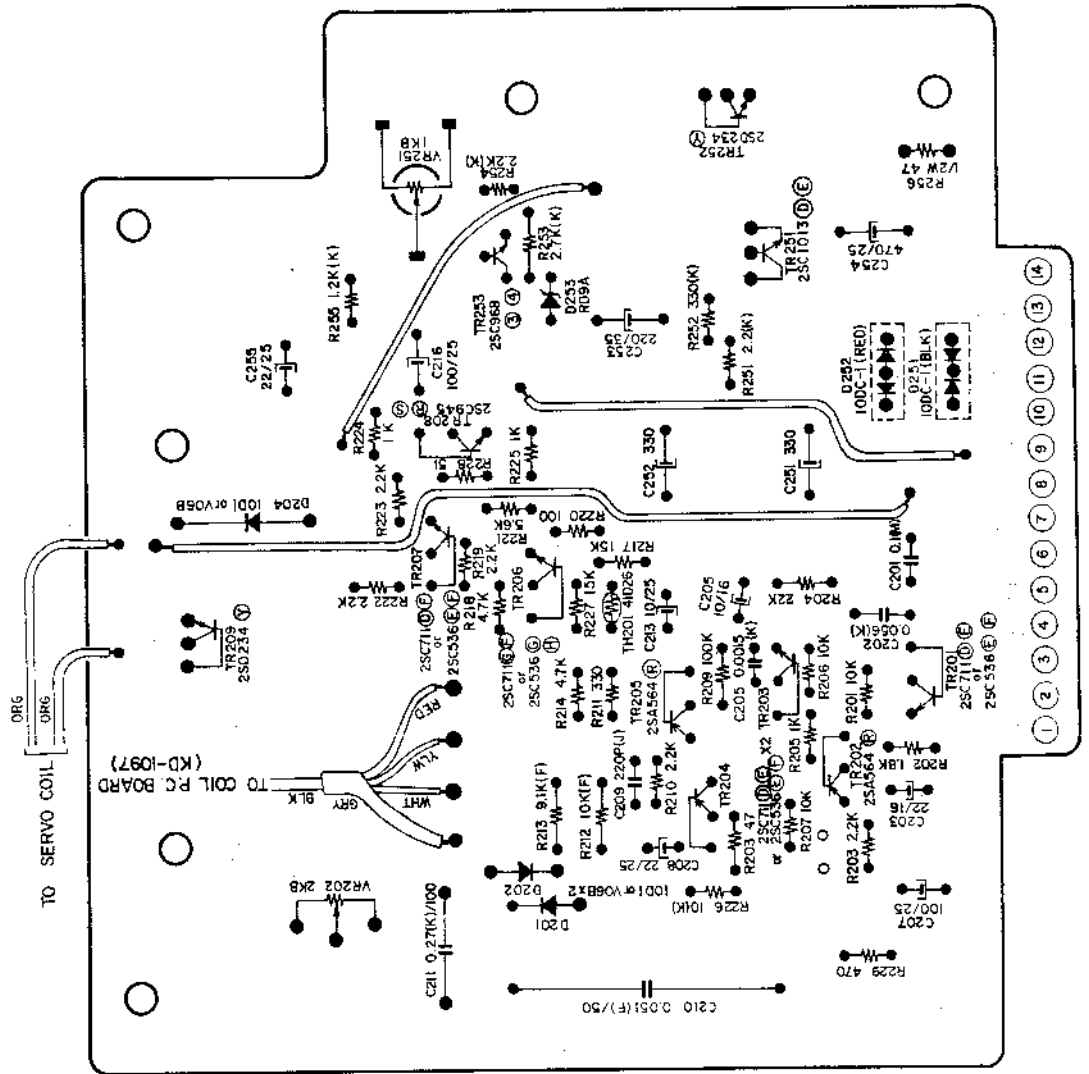
# TAPE SPEED SWITCH P.C. BOARD (KH-2011)



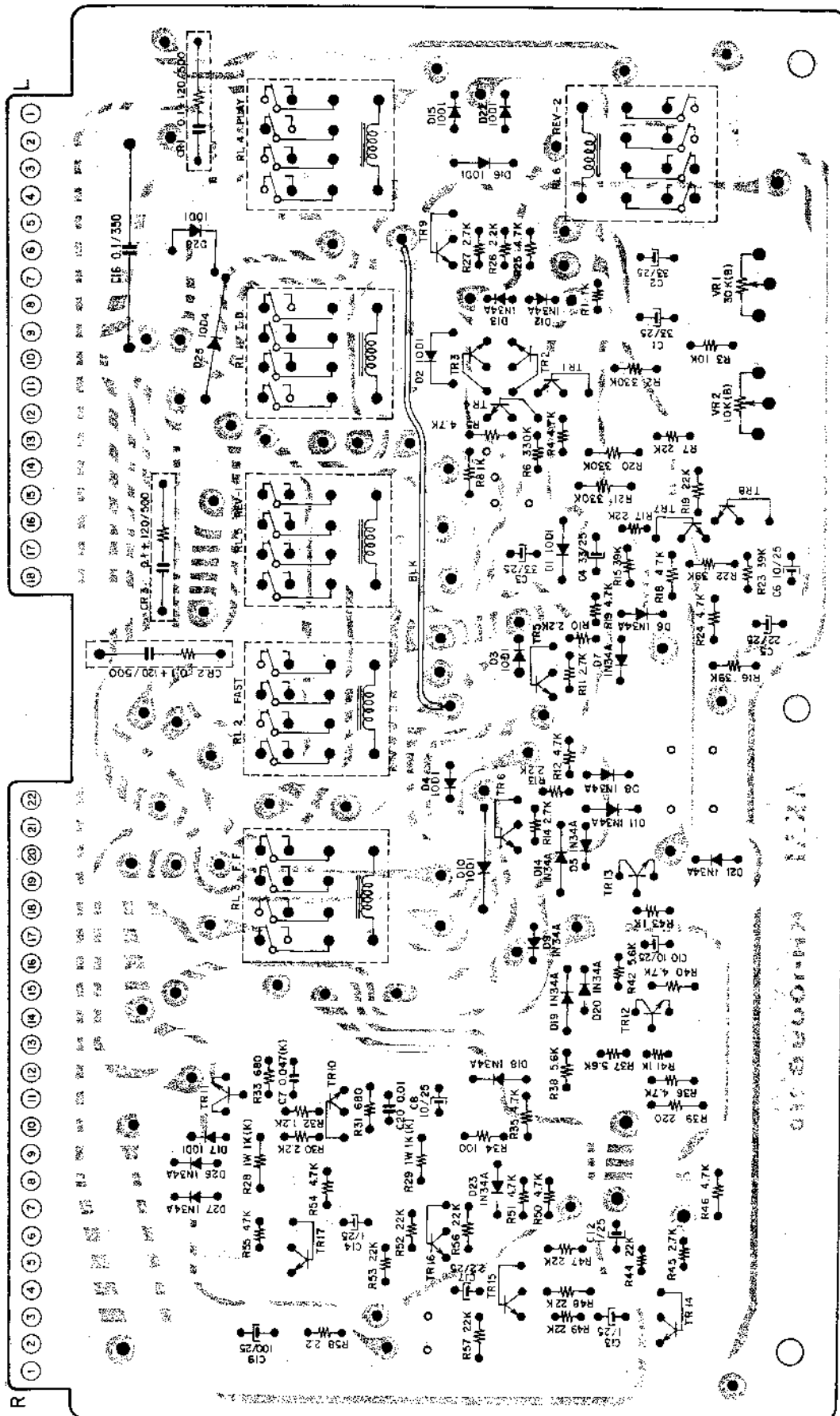
# COIL P.C. BOARD (KD-1097 2ED)



# SERVO P.C. BOARD (KH-1011)

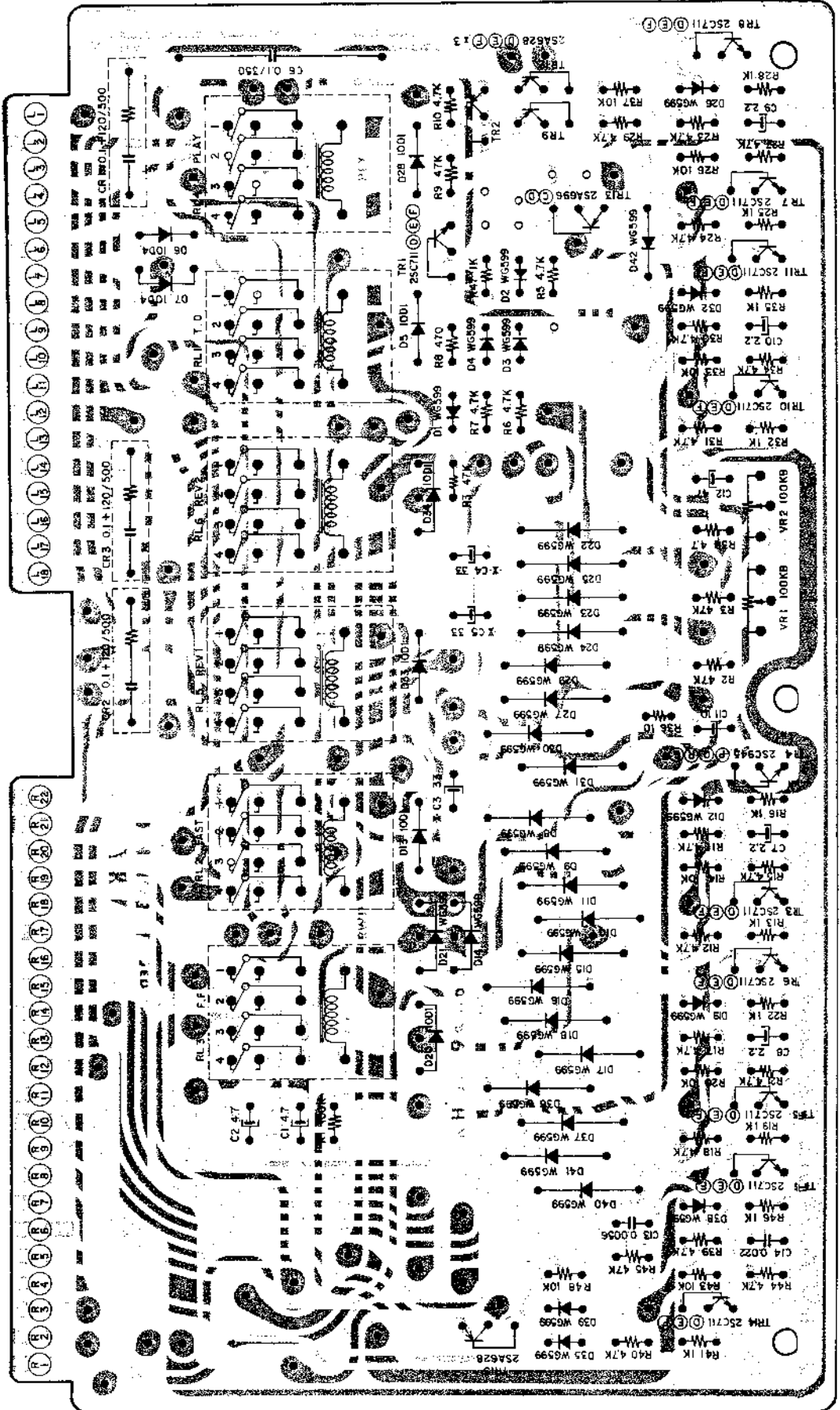


SYSTEM CONTROL P.C. BOARD (KH-1009)



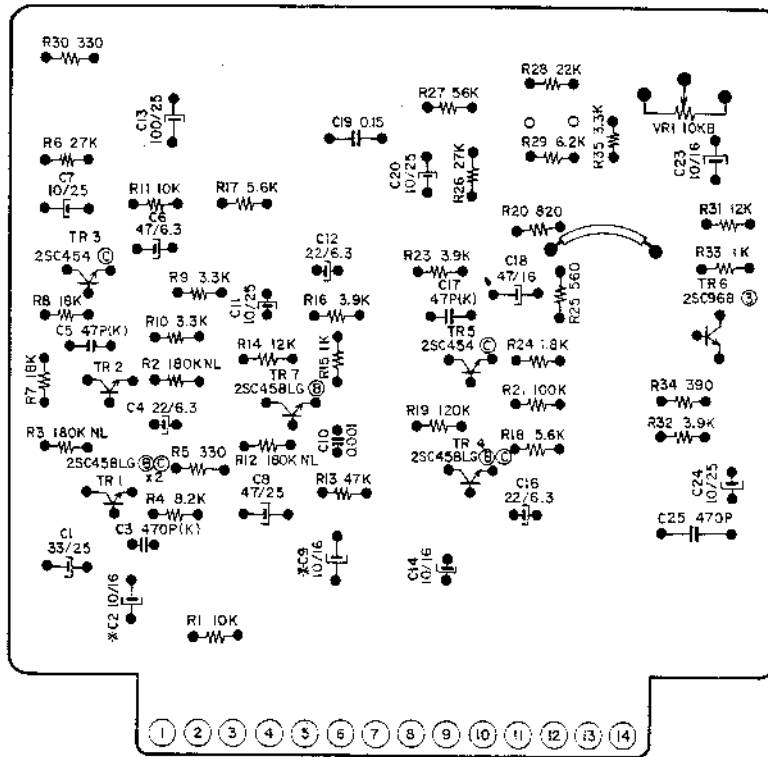
TR1 to 10, TR14 to 17 ..... 25C945 (C) (D) TR11 to 13 ..... 25C956 (C) (D) RL1 to 6, MY4-O-05-AD4 DC24V

SYSTEM CONTROL P.C. BOARD (KH-1039)

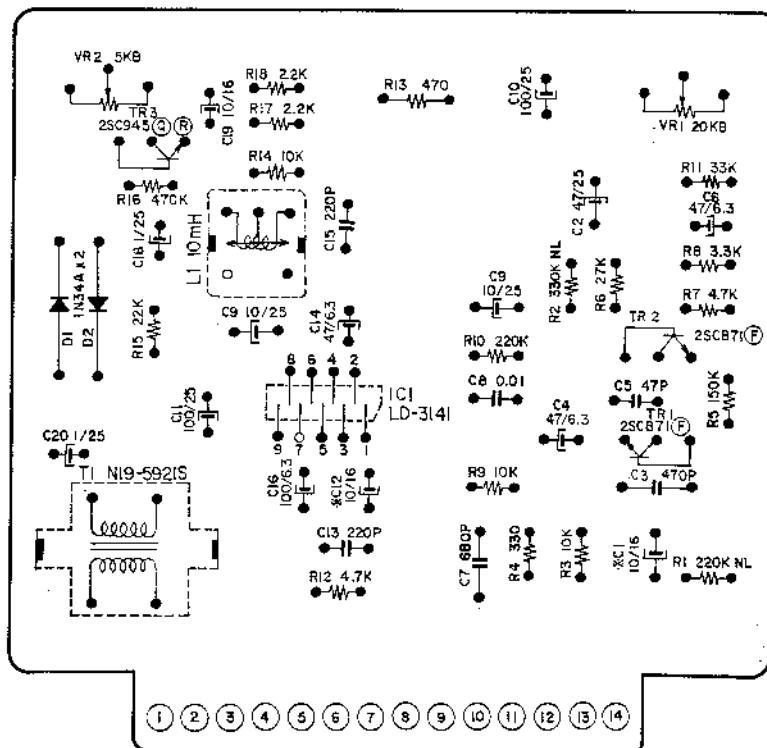


RL1 TO 6 : MY4 0-US-404 DC 24V

REC. AMP. P.C. BOARD (KH-5013)

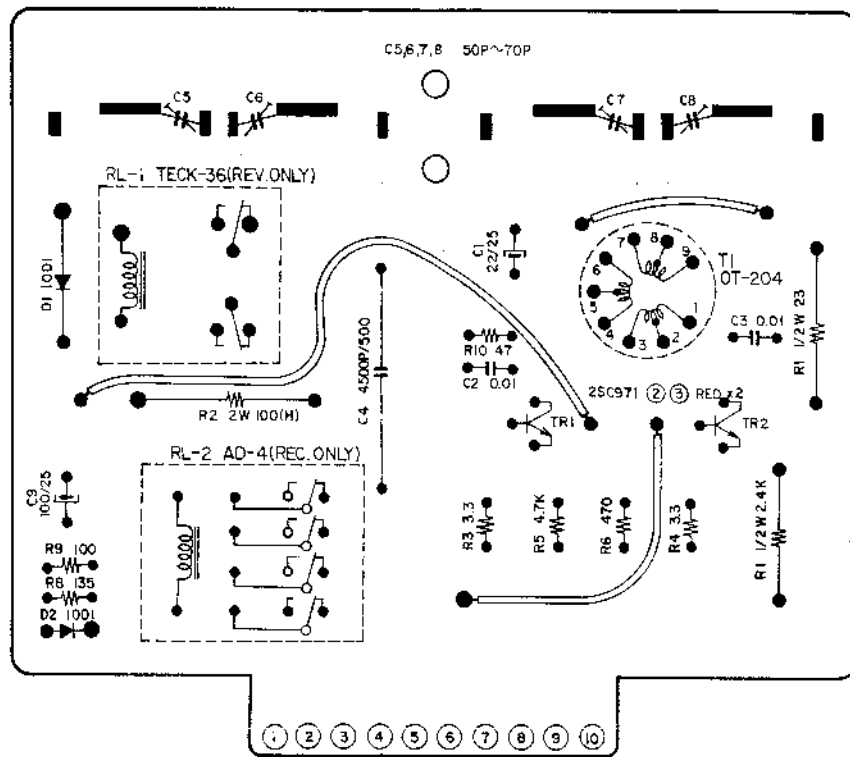


P.B. AMP P.C. BOARD (KH-5014)

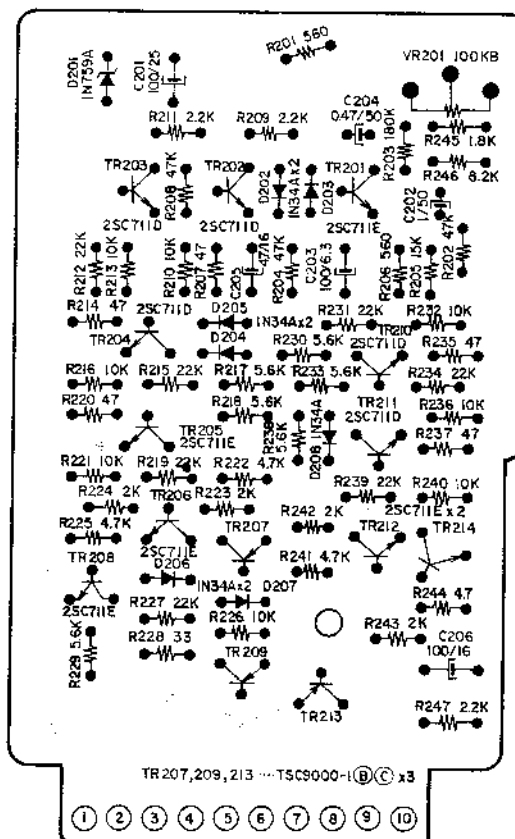




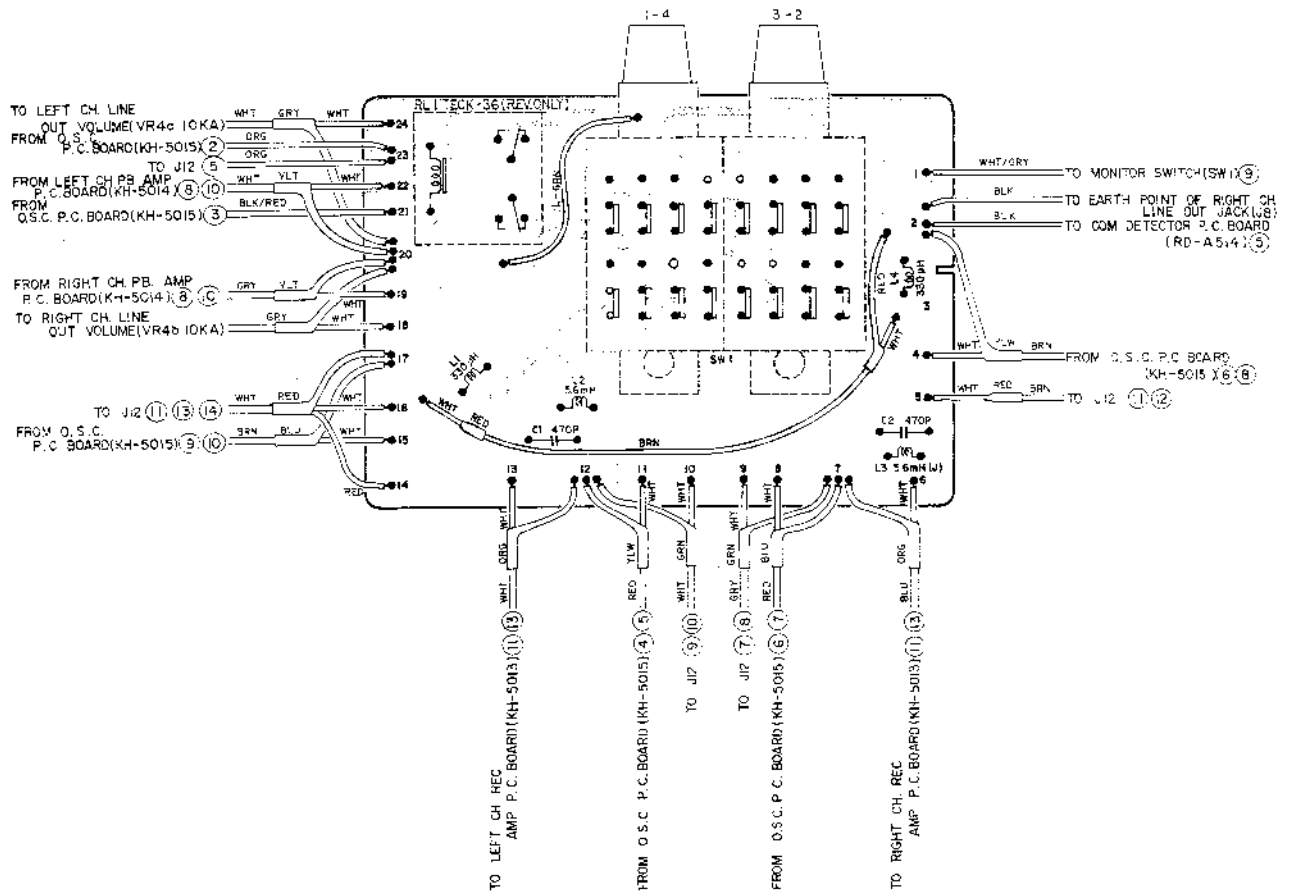
OSC. P.C.



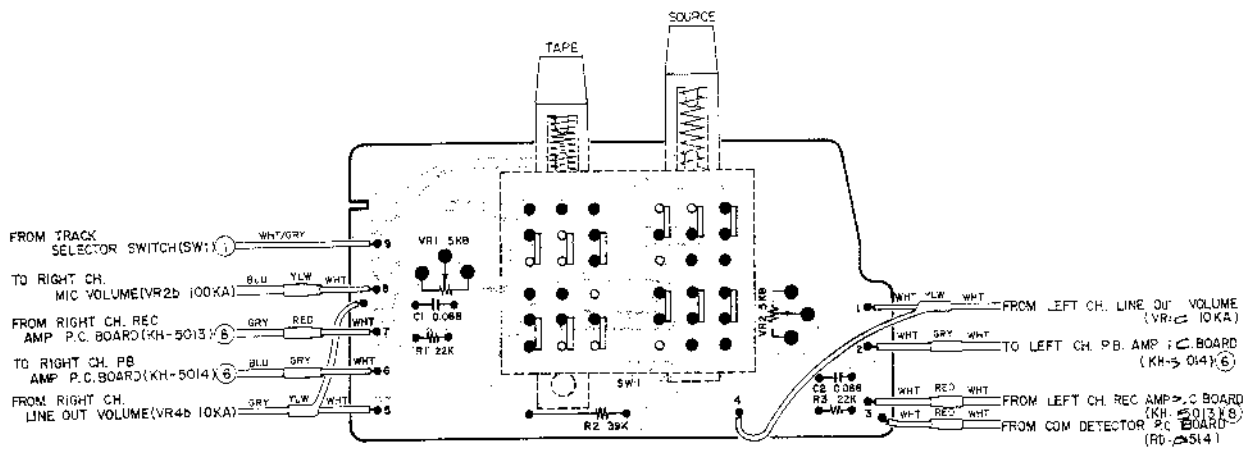
COM DETECTOR P.C. BOARD (RD-A514)



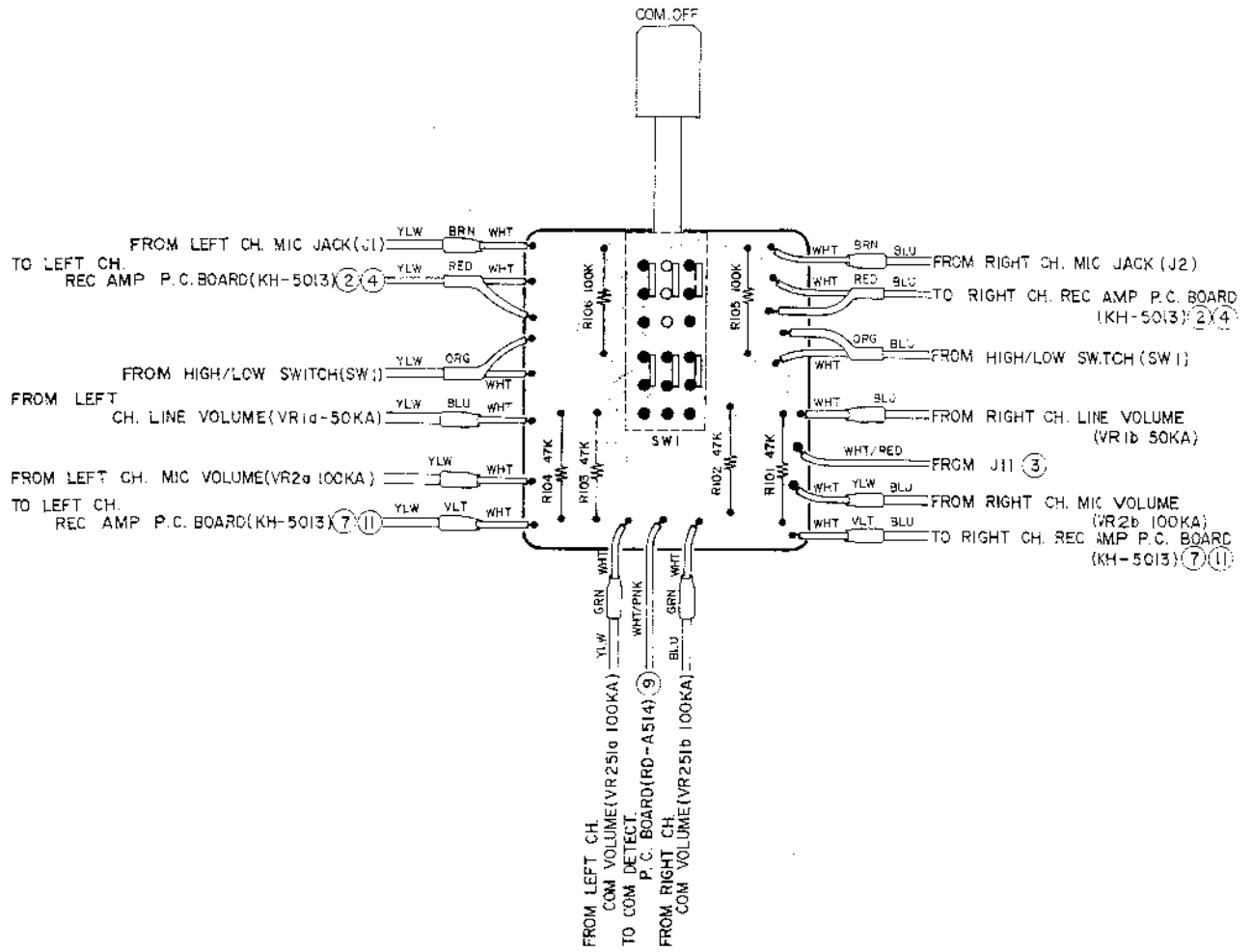
## TRACK SELECTOR P.C. BOARD (KH-5011)



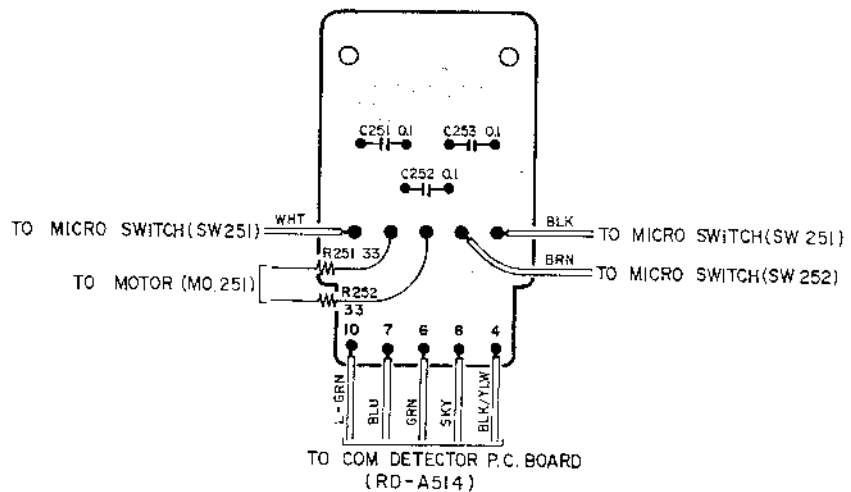
## MONITOR SWITCH P.C. BOARD (KH-5012)



COM SWITCH P.C. BOARD (RD-525 2ED)



TERMINAL P.C. BOARD (RD-A512 2ED)





---

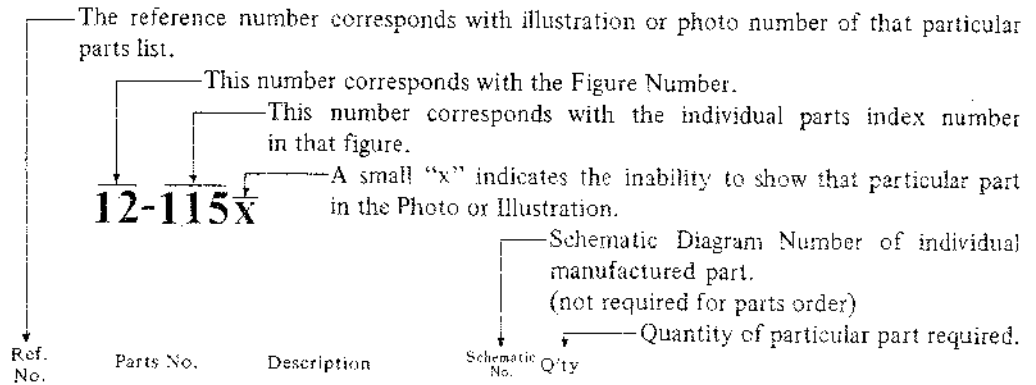
SECTION 2  
**PARTS LIST**

TABLE OF CONTENTS

FIG. 1	KH HEAD BLOCK .....	49
FIG. 2	MAIN MOTOR BLOCK (SCM-24) .....	51
FIG. 3	REEL MOTOR/REEL TABLE BLOCK .....	53
FIG. 4	IMPEDANCE ROLLER BLOCK .....	54
FIG. 5	POWER & PAUSE SWITCH BLOCK .....	55
FIG. 6	OPERATION BLOCK .....	57
FIG. 7	POWER SUPPLY BLOCK .....	59
FIG. 8	MECHANISM ASSEMBLY BLOCK .....	62
FIG. 9	TAPE SPEED SWITCH P.C. BOARD (KH-2011) BLOCK ..	64
FIG. 10	COIL P.C. BOARD (KD-1097) BLOCK .....	64
FIG. 11	SERVO P.C. BOARD (KH-1011) BLOCK .....	65
FIG. 12	SYS. CON. P.C. BOARD (KH-1009 & KH-1039) BLOCK ..	67
FIG. 13	REC. AMP. P.C. BOARD (KH-5013) BLOCK .....	68
FIG. 14	P.B. AMP. P.C. BOARD (KH-5014) BLOCK .....	69
FIG. 15	OSC. P.C. BOARD (KH-5015) BLOCK .....	70
FIG. 16	COM DETECTOR P.C. BOARD (RD-A514) BLOCK .....	70
FIG. 17	TRACK SELECTOR P.C. BOARD (KH-5011) BLOCK .....	71
FIG. 18	MONITOR SWITCH P.C. BOARD (KH-5012) BLOCK .....	72
FIG. 19	COM SWITCH P.C. BOARD (RD-525) BLOCK .....	72
FIG. 20	COM MECHANISM BLOCK .....	73
FIG. 21	AMP. ASSEMBLY BLOCK .....	75
FIG. 22	FINAL ASSEMBLY BLOCK .....	76
INDEX .....		77

## HOW TO USE THIS PARTS LIST

1. This parts list is compiled by various individual blocks based on assembly process.
2. When ordering parts, please describe parts number, serial number, and model number in detail.
3. How to read List



### FLYWHEEL BLOCK #13

Ref. No.	Parts No.	Description	Schematic No.	Qty
12-115x	800425	Flywheel Block Assy. Comp.	RD-233	1
12-116	244506	Flywheel Only	RD-233	1
12-117x	244754	Felt, Flywheel	RD-273	1
12-118	251324	Main Metal Case	RD-236	1
12-119	253080	Main Metal	RD-237	1

4. The symbol numbers shown on the P.C. Board list can be matched with the Composite Views of components of the Schematic Diagram or Service Manual.
5. The indications of Resistors and Capacitors in the photos of P.C. Board are being eliminated.
6. The shape of the parts and parts name, etc. can be confirmed by comparing them with the parts shown on the Electrical Parts List Table of P.C. Board.
7. Both the kind of part and installation position can be determined by the Parts Number. To determine where a parts number is listed, utilize Parts Index at end of Parts List.  
It is necessary first of all to find the Parts Number. This can be accomplished by using the Reference Number listed at right of parts number in the Parts Index. (meaning of ref. no. outlined in Item 3 above).
8. Utilize separate "Price List for Parts" to determine unit price. The most simple method of finding parts Price is to utilize the reference number.

## ELECTRICAL PARTS LIST TABLE

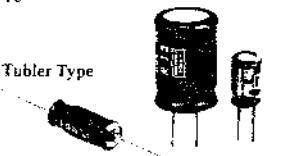
<p><b>ELECTRICAL PARTS LIST TABLE</b>                  Because the indication of resistors and capacitors in the P.C. Board photos are being eliminated, please confirm parts name and shape by comparing them with the parts shown in this table.</p>	1  Solid Resistor	2 Stopper Type  Insulator Type Carbon Resistor	3  Metal Oxide Film Resistor	
	4  Cement Resistor	5  Wire-Wound Resistor	6  Thermistor	7  Enamel Resistor
	1  MP Capacitor (Tubler Type)	2  Plastic Capacitor	3  Mylar Capacitor	4  VFM (HJ-Q) Capacitor
	5  Mylar Capacitor	6  Tantalum Capacitor	7  Oil Capacitor (Tubler Type)	8 Vertical Type Tubler Type  Styrol Capacitor
9  Electrolytic Capacitor (Tubler Type)	10 Vertical Type Tubler Type  Electrolytic Capacitor	11  Ceramic Capacitor	12  Metalized Mylar (Paper) Capacitor	
13  Trimer Condenser		VR  Semi-Fixed Volume		
L  Ferri Inductor	TR  Transistor			
CR  Spark Quencher	D  Diode (Silicon, Zener, Germanium)			

FIG. 1 (A) ILLUSTRATION OF KH HEAD BLOCK

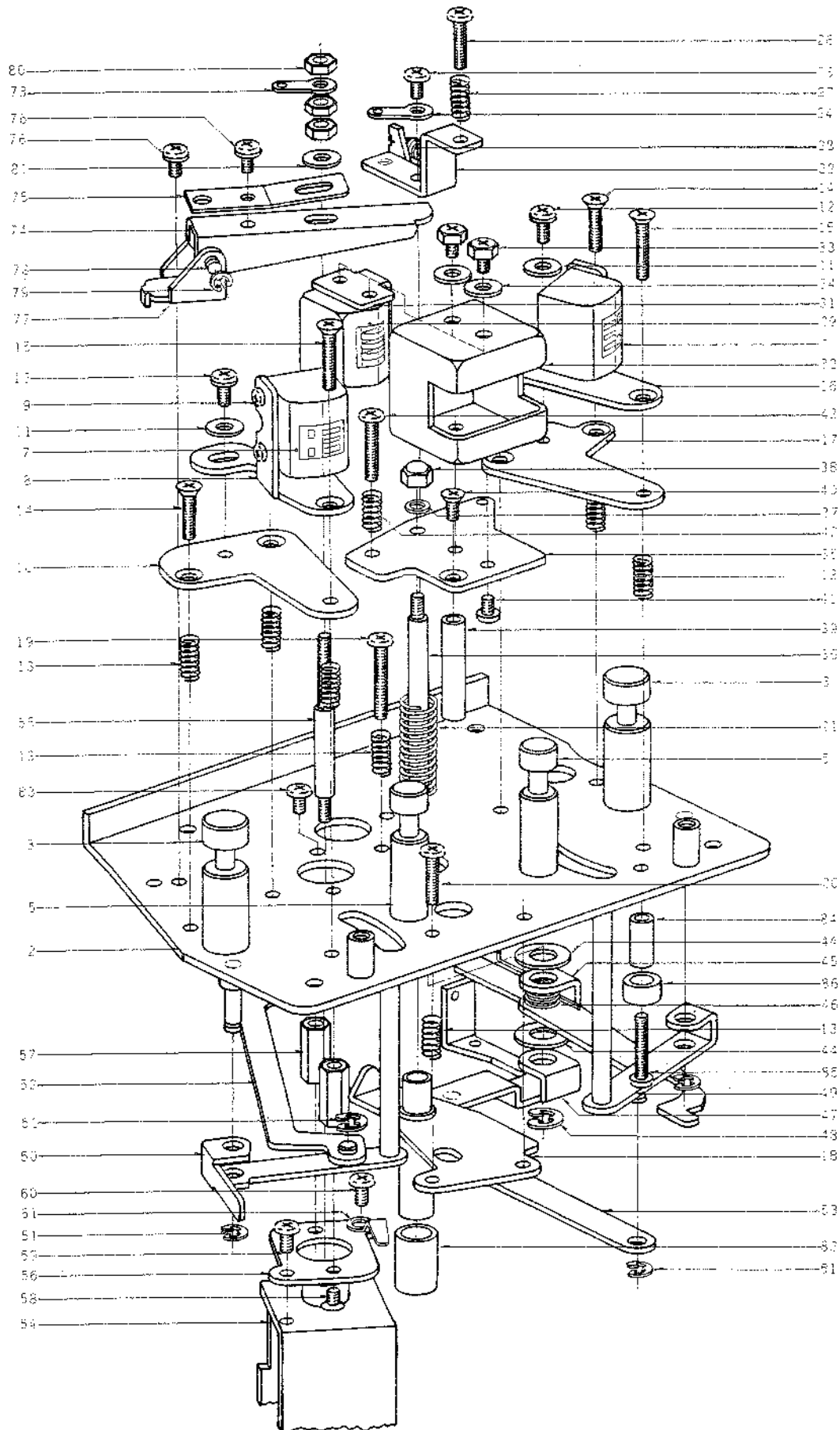
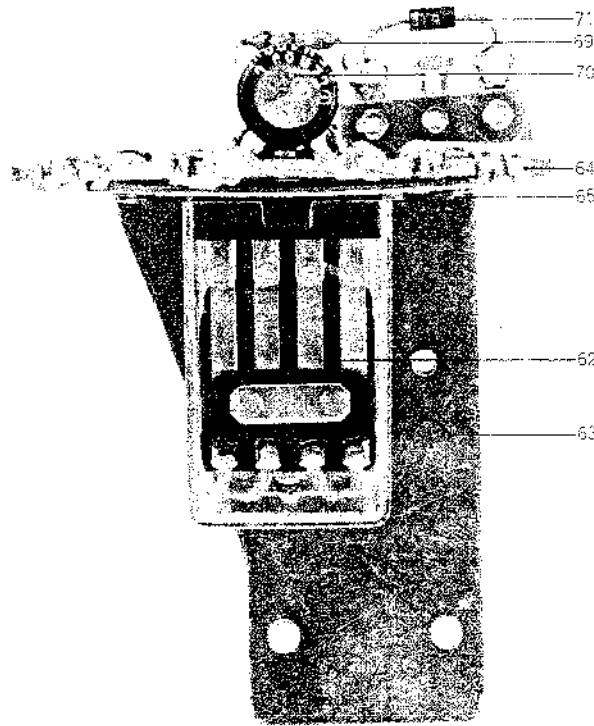




FIG. 1 (B) PHOTO OF KH HEAD BLOCK

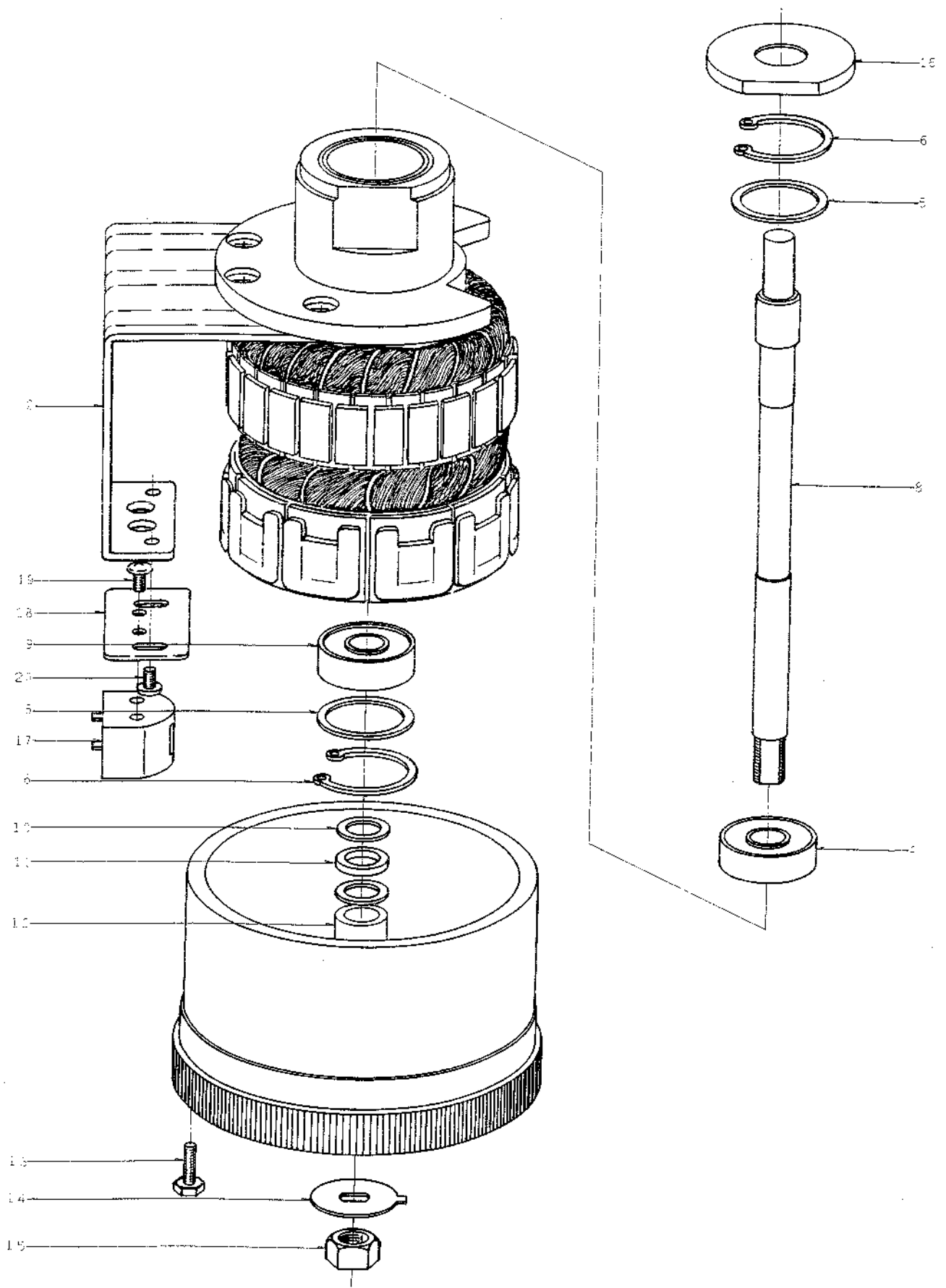


**KH HEAD BLOCK**

Ref. No.	Parts No.	Description	Schematic No.	Qty
1-1x	BH432310	KH Head Block Comp.	KH	1
1-2	HZ473084	Head Chassis, w/pin	KH-0001	1
1-3	HZ473332	Tape Guide B	KH-0027	2
1-4x	ZW434250	Screw, pan head 4x8, w/washer		2
1-5	HZ482714	Tape Guide C	KH-0052	2
1-6x	ZW414033	Screw, countersunk head 3x8		2
1-7	HR482321	REC./ERASE HEAD RE4-t		2
1-8	HZ473152	Combo Head Angle B	KH-0008	1
1-9	ZW477876	Screw, pan head 2x3		6
1-10	HZ473343	Combo Head Base B	KH-0033	1
1-11	ZW413256	Washer (SPC) D3.4x7.8x0.5t		2
1-12	ZW413728	Screw, binding head 3x6, w/washer		2
1-13	ZG303300	Angle Adjust Spring B	RD-55	9
1-14	ZW419793	Screw, countersunk head 3x12		4
1-15	ZW482736	Screw, countersunk head 3x15		2
1-16	HZ473141	Combo Head Angle A	KH-0007	1
1-17	HZ473163	Combo Head Base A	KH-0009	1
1-18	HZ473185	PH Head Chassis B, w/metal	KH-0011	1
1-19	ZW439514	Screw, binding head 3x18		1
1-20	ZW413785	Screw, binding head 3x12		2
1-21	ZG473218	Reverse Spring	KH-0014	1
1-22	HZ473174	Head Height Adjust Table	KH-0010	1
1-23	ZW413155	Screw, binding head 3x6		1
1-24	ZW273778	M3 Earth Lug		2
1-25x	ZW273802	M3 Toothed Lock Washer		1
1-26	ZW413785	Screw, binding head 3x12		1
1-27	ZG303300	Angle Adjust Spring B	RD-55	1
1-28	ZG810055	PH Hold-down Pull Spring	RD-52	1
1-29	HP384524	P.B. HEAD P4-200		1
1-30x	EA463206	P.C. Board, Terminal A	RD-A36	2
1-31	HZ473130	PH Head Angle	KH-0006	1
1-32	HZ382667	Triple-shield	RD-A3	1
1-33	ZW375963	Hexagon Bolt 3x4		2
1-34	ZW413256	Washer (SPC)D3.4x7.8x0.5t		2

Ref. No.	Parts No.	Description	Schematic No.	Qty
1-35	HZ473128	PH Head Chassis A	KH-0005	1
1-36	MH473207	UD Shaft	KH-0013	1
1-37	ZW259648	Washer (PBP)D3x5x0.1t		1
1-38	ZW482758	M3 Cap Nut		1
1-39	HZ809976	PH Hold-down Guide	RD-14	1
1-40	ZW432685	Screw, countersunk head 3x6 D=5		1
1-41	ZW413223	Screw, binding head 3x5, w/washer		2
1-42	ZG303300	Angle Adjust Spring B	RD-55	1
1-43	ZW417148	Screw, binding head 3x15		1
1-44	ZW260188	Washer (Nylon)D6.2x1.3x0.5t		2
1-45	HZ473231	Stopper	KH-0017	1
1-46	ZG473321	Stopper Spring	KH-0026	1
1-47	HL473242	Shifter Lever 1, w/pin	KH-0016	1
1-48	ZW270134	'E' Ring 5M	6-1-9	1
1-49	HL473253	Shifter Lever 2, w/pin	KH-0019	1
1-50	HL473264	Shifter Lever 3, w/pin	KH-0020	1
1-51	ZW270101	'E' Ring 3M	6-1-9	6
1-52	HZ473297	Shifter Joint A	KH-0023	1
1-53	HZ473308	Shifter Joint B	KH-0024	1
1-54	EP804813	Plunger Solenoid M-10B-34V	44-1-16	1
1-55	HZ473365	Plunger Joint	KH-0031	1
1-56	HZ473354	Plunger Base	KH-0015	1
1-57	HZ321344	Plunger Retaining Prop	RD-7	2
1-58	ZW432685	Screw, countersunk head 3x6 D=5		2
1-59	ZW413728	Screw, binding head 3x6, w/washer		1
1-60	ZW413155	Screw, binding head 3x6		1
1-61	HZ321366	Retaining Plate	3A-72	1
1-62	EP344136	Relay MY4-0-US-AD4-24V	47-1-8	1
1-63	HZ473220	Relay Mt. Parts	KH-0018	1
1-64	EA473376	Head Relay P.C. Board	KH-0029	1
1-65	ZW461935	Screw, round head 2.6x4		4
1-66x	ZW317801	M2.6 Toothed Lock Washer		1
1-67x	EA222096	Connector P.C. Board	RD-140	1
1-68x	EZ328320	Nylon Clip HP-5N		1
1-69	ER361563	Carbon/R. RD1/4 180(J) (Stop. type)	35-10-1	1
1-70	EC220151	Elect./C. 100 µF 25WV (Vert. type)	24-12-91	1
1-71	ED224526	Silicon Diode 10D1	48-2-11	1
1-72x	HZ488092	P.C. Board Shield (for connectio)	KH-0053	2
1-73	ZW273778	M3 Earth Lug		1
1-74	HL809998	PH Hold-down Lever	RD-21	1
1-75	ZG246857	Pull Lever Spring	RD-22	1
1-76	ZW413223	Screw, binding head 3x5, w/washer		2
1-77	HL473387	PH Hold-down Lever Support	KH-0032	1
1-78	ZW257477	Connecting Pin	RD-211	1
1-79	ZW270088	'E' Ring 1.9M	6-1-9	1
1-80	ZW273756	M3 Nut		5
1-81	ZW413256	Washer (SPC)D3.4x7.8x0.5t		1
1-82	HZ321434	Dust-proof Cap B	RD-54	1
1-83	ZW417025	Screw, binding head 3x8, w/washer		2
1-84	HZ434272	Shifter Stopper Collar	KD-A0010	1
1-85	ZW417148	Screw, binding head 3x15		1
1-86	MZ428343	KD Stopper Rubber	KD-1088	1

FIG. 2 ILLUSTRATION OF MAIN MOTOR BLOCK (SCM-24)



## MAIN MOTOR BLOCK (SCM-24)

Ref. No.	Parts No.	Description	Schematic No.	Qty
2-1x	BM482286	Main Motor Block (SCM-24)		
		Comp.	KH, KD, KF	1
2-2	MZ405437	Detector Head Mt. Base	KD-7029	1
2-3x	ZW419747	Screw, countersunk head 4x6		4
2-4	MV408510	Bearing 608VVC2E-AV2-L	100707	1
2-5	ZW398125	Adjust Washer A	KD-7019	2
2-6	ZW206021	'C' Ring (hollow) D22	6-1-2	2
2-7x	ZW391476	Set Screw, hexagon socket 4x4(cup)		1
2-8	MS473657	Motor Shaft	KH-7001	1
2-9	MV248130	Bearing 608VVC2E-B32	100707	1
2-10	ZW321592	Washer (SUS)D8.1x13x0.3t		2
2-11	ZW356883	Washer (Hycar)D8.3x11.8x0.5t		3
2-12	ZW424203	Spacer	KD-7057	1
2-13	ZW403525	Hexagon Bolt 3x10		4
2-14	ZW398158	Servo Motor Anti Loosening Washer	KD-7022	1
2-15	ZW403536	M7 Nut P=0.5		1
2-16	MZ398182	Cap	KD-7026	1
2-17	HK398452	DETECTOR HEAD	KH, KD, KF	1
2-18	MZ400421	Detector Head Plate	KD-3008	1
2-19	ZW201475	Screw, pan head 2x3		2
2-20	ZW413155	Screw, binding head 3x6		2

When ordering parts, please describe Parts Number, Serial Number, and Model Number in detail.



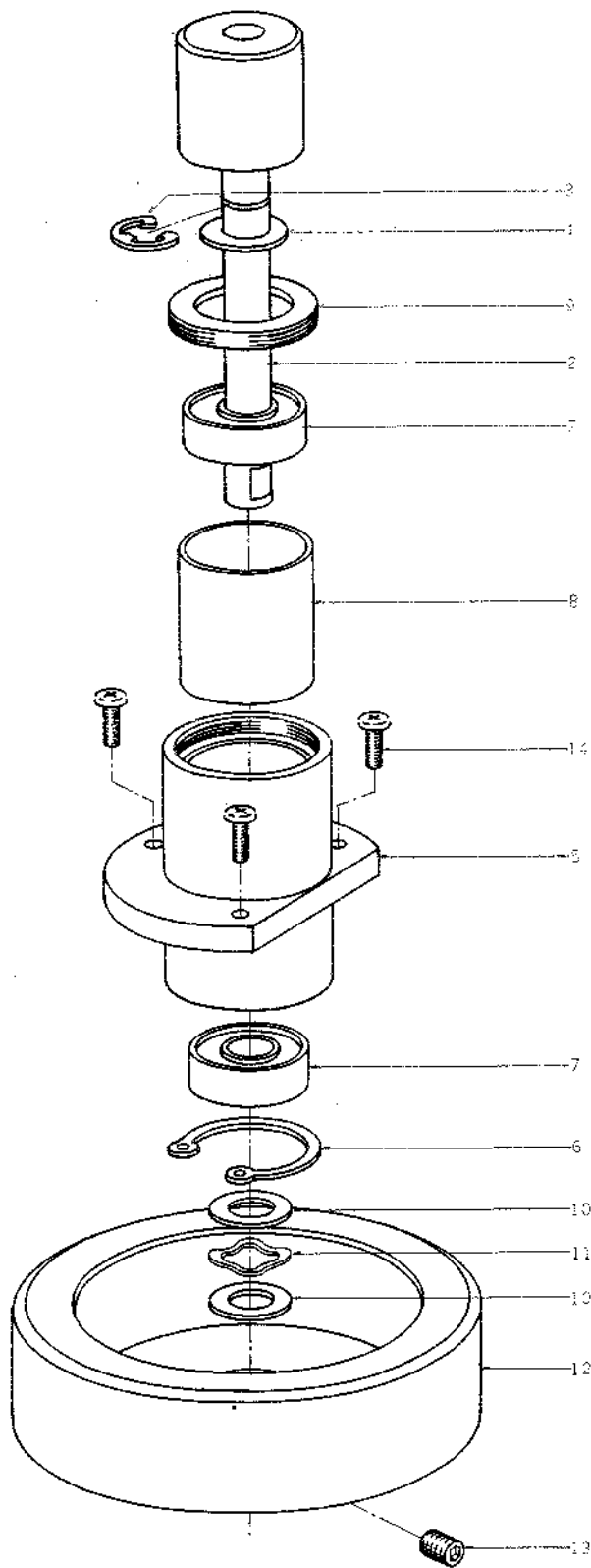
## REEL MOTOR/REEL TABLE BLOCK

Ref. No.	Parts No.	Description	Schematic No.	Qty
<b>REEL MOTOR BLOCK</b>				
3-1	BM314741	Reel Motor Block (24XO-2)	KD, MR, MS, MC	2

<b>REEL TABLE BLOCK</b>				
3-2x	BR482400	Supply Reel Table Comp.	KH, MR, MC	1
3-3x	BR482411	Take-up Reel Table Comp.	KH, MR, MC	1
3-4	MT488147	RD Reel Table Disk B	RD-272	2
3-5	MT255420	Reel Retainer	3R-102	2
3-6	MS342000	Reel Shaft	3R-108	2
3-7	ZG255633	Reel Spring	3R-109	2
3-8	MT297663	3R 'O' Ring 2.9x1.65M	3R-139	2
3-9	ZW270088	'E' Ring 1.9M	6-1-9	2
3-10	MT473422	Reel Table Rubber (KH)	KH-2042	2
3-11x	MT473444	Brake Drum (left) (Supply)	KH-2031	1
3-12	MT473433	Brake Drum (right) (Take-up)	KH-2031	1
3-13x	ZW273778	M3 Earh Lug		2
3-14	MT436860	Brake Cloth Comp.	MR-269	2
3-15	ZG317496	Felt Tension Spring	MR-260	2
3-16x	ZW425981	Screw, binding head 3x3		2
3-17	MR317507	Counter Pulley (Take-up)	MR-217	1
3-18	ZW365973	Screw, countersunk head 2.3x12		2
3-19	ZW424056	Screw, pan head 4x10		4
3-20	ZW403222	Screw, countersunk head 3x10		6
3-21	MZ317373	Brake Lever Prop	MR-102	2
3-22x	ZW413188	M4 Nut		2
3-23	ML314976	Brake Lever A (Take-up)	MR-210	1
3-24x	ML396810	Brake Lever B (Supply)	KD-1038	1
3-25	MB314987	Brake Band	MR-213	2
3-26	MZ314998	Brake Band Retaining Plate	MR-212	4
3-27	MZ315000	Brake Band Support	MR-214	2
3-28x	ZW323728	Screw, binding head 3.5		8
3-29	ZW290283	'U' Ring 2.85M	6-1-1	2
3-30	ZG315011	Brake Lever Spring	MR-116	2
3-31	MZ317406	Brake Band Guide, w/base	MR-126	2
3-32	MB303535	Counter Belt D91x1.6	3A-617	1

When ordering parts, please describe Parts Number, Serial Number, and Model Number in detail.

FIG. 4 ILLUSTRATION OF IMPEDANCE ROLLER BLOCK

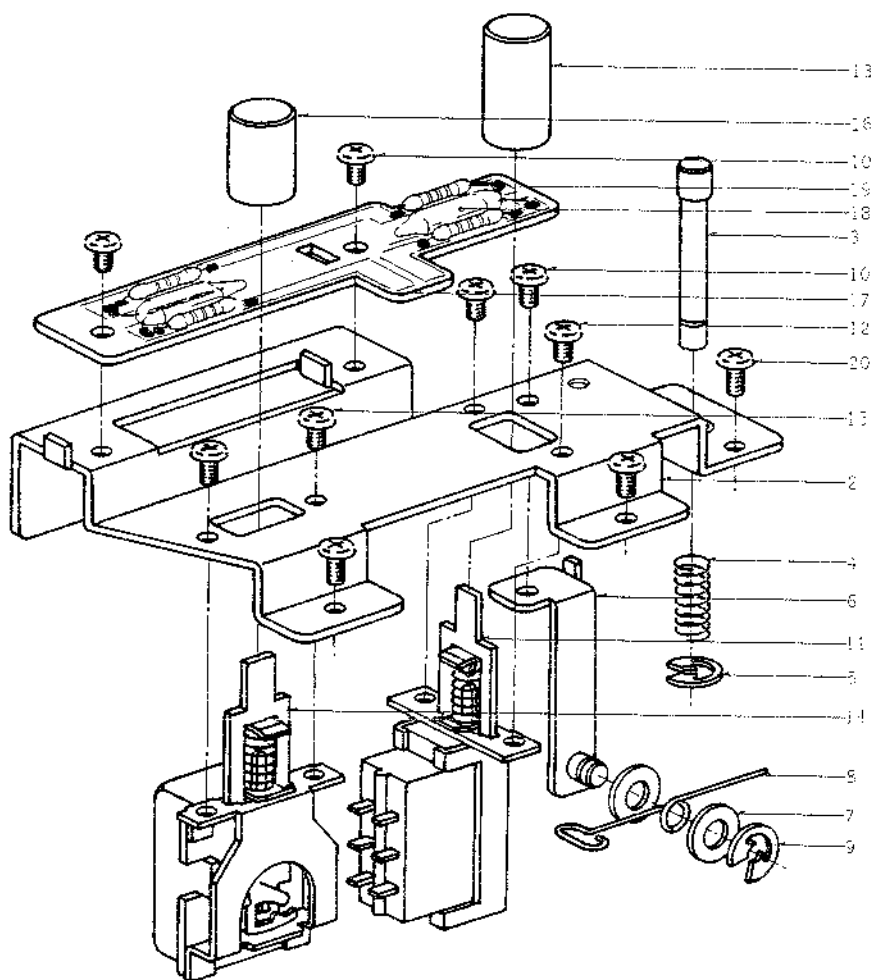


**IMPEDANCE ROLLER BLOCK**

Ref. No.	Parts No.	Description	Schema No.	Q'ty
4-1x	BL482422	Impedance Roller Block Comp.	KR	1
4-2	MS473916	Impedance Roller Arm Shaft, w/roller	KH-036	1
4-3	ZW334653	'E' Ring 7M	6-19	1
4-4	ZW321592	Washer (SUS)D8.1x13x0.3t		1
4-5	BC473927	Impedance Case	KH-032	1
4-6	ZW206021	'C' Ring (hollow) D22	6-19	1
4-7	MV248141	Bearing 608VVC2E-B32-L		2
4-8	MZ473938	Bearing Collar	KH-033	1
4-9	ZW292667	Z Bearing Screw	3A-15	1
4-10	ZW260256	Washer (PBP)D8.1x13x0.1t		2
4-11	ZG300431	8M/M Oil-pressure Spring WW-8	6-20	1
4-12	MZ292678	Z Wheel	RD-15	1
4-13	ZW487912	Set Screw, hexagon socket 5x6(cup)		2
4-14	ZW413201	Screw, pan head 4x8		3

When ordering parts, please describe Parts Number, Serial Number, and Model Number in detail.

FIG. 5 ILLUSTRATION OF POWER & PAUSE SWITCH BLOCK



**POWER & PAUSE SWITCH BLOCK**

Ref. No.	Parts No.	Description	Schematic No.	Q'ty	Ref. No.	Parts No.	Description	Schematic No.	Q'ty
5-1x	BS482308	Power & Pause Switch Comp.	KH	1	5-12	ZW444273	Iso Screw, binding head 3x4		2
5-2	MZ474006	Power & Pause Switch Table, w/metal	KH-2050	1	5-13	SB474118	Push Button 3	KH-1023	1
5-3	MS473962	Pause Lock Shaft	KH-2005	1	5-14	ES468426	Push Switch UEH-12BFN	25-5-58	1
5-4	ZG473973	Pause Spring	KH-2006	1	5-15	ZW371856	Iso Screw, binding head 3x5		2
5-5	ZW482635	'U' Ring 2.85M	6-1-1	1	5-16	SK482646	Knob B-1	MC-5011	1
5-6	MZ473995	Spring Mt. Plate, w/pin	KH-2049	1	5-17	EA487991	Neon Lamp P.C. Board	KH-1031	1
5-7	ZW420682	Washer (Nylon)D4.2x9x0.5t		2	5-18	EL236125	Neon Lamp NE-68	28-3-3	2
5-8	ZG472770	Pause Spring B	KH-2009	1	5-19	ER345756	Carbon/R. RD1/4 68k(J) (Insu. type)	25-9-5	4
5-9	ZW290283	'U' Ring 2.85M	6-1-1	1					
5-10	ZW417137	Screw, binding head 3x4		3	5-20	ZW323728	Screw, binding head 3x5		3
5-11	ES482938	Push Switch JH-3	25-5-61	1					

FIG. 6 (A) ILLUSTRATION OF OPERATION BLOCK

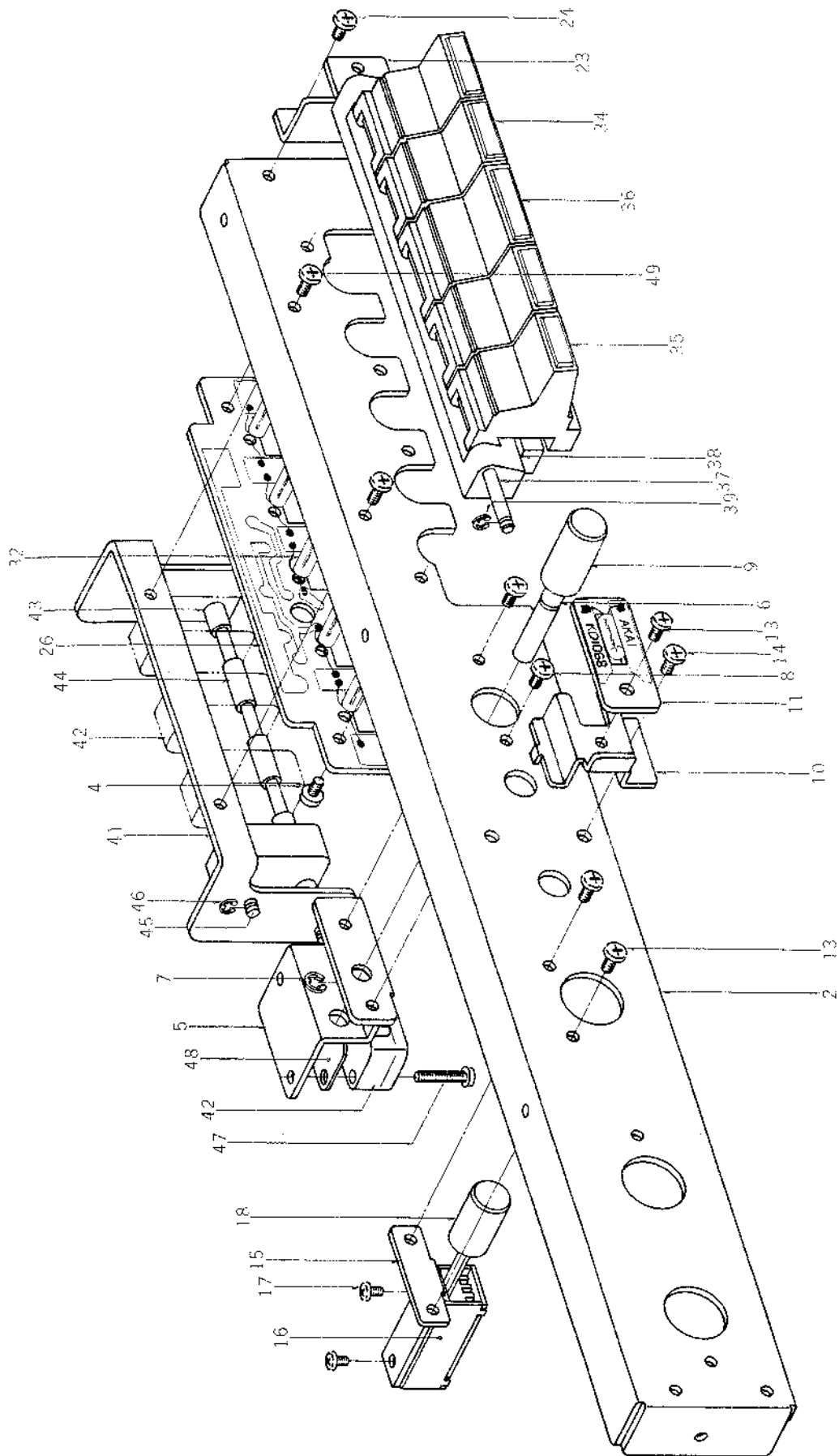
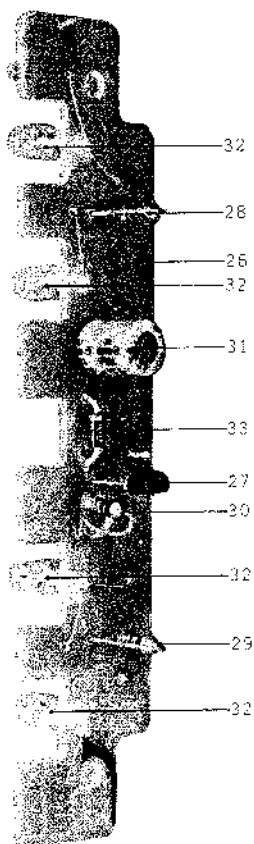




FIG. 6 (B) PHOTO OF OPERATION BLOCK



OPERATION BLOCK

Ref. No.	Parts No.	Description	Schematic No.	Q'ty
6-1x	BZ482376	Operation Block Comp.	KH	1
6-2	BZ472656	Operation Frame	KH-2016	1
6-3x	BA482398	Operation Lamp P.C. Board Comp. (KH-2019)		1
6-4	ZW323728	Screw, binding head 3x5		2
6-5	EZ397956	Rec. Button Bracket	KD-5015	1
6-6	MZ472667	Rec. Push Rod	KH-2028	1
6-7	ZW270101	'E' Ring 3M	6-1-9	1
6-8	ZW323728	Screw, binding head 3x5		2
6-9	SK472678	Rec. Knob	KH-2027	1
6-10	MZ472680	Rec. Lamp Mt. Plate	KH-2040	1
6-11	EA396898	Neon Lamp P.C. Board	KD-1068	1
6-12x	EL390576	Pilot Lamp RM6-24V-50MA	28-2-6	1
6-13	ZW323728	Screw, binding head 3x5		3
6-14	ZW472274	Tapping Screw #2 3x6		1
6-15	MZ472691	SRT Switch Mt. Part	KH-2024	1
6-16	ES482861	Push Switch UEG-63A	25-5-63	1
6-17	ZW442585	Screw, binding head 2.6x4		2
6-18	SK482850	Knob B-1	KF-2019	1
6-19x	BA482387	Tape Speed Switch P.C. Board Comp. (KH-2011)		1
6-20x	ZW371856	Iso Screw, binding head 3x5		2
6-21x	SB474052	Push Button 1	KH-1022	2
6-22x	ZW259413	Washer (ALP)D2.7x4.9x1t	BT-112	1
6-23	MZ472792	Amp. Panel Retaining Metal	KH-2029	2
6-24	ZW472274	Tapping Screw #2 3x6		4
6-25x	BA482398	Operation Lamp P.C. Board Comp. (KH-2019)		1
6-26	EA472724	Operation Lamp P.C. Board (KH-2019)	KH-2019	1
6-27	ET398711	Transistor 2SC945(Q)(R)	45-1-85	1
6-28	ER430053	Carbon/R. RD1/4 22(J) (Stop. type)	35-10-1	1
6-29	ER212883	Carbon/R. RD1/4 4.7k(J) (Stop. type)	35-10-1	1
6-30	ER211465	Carbon/R. RD1/4 1k(J)	35-10-1	1
6-31	EC220364	Elect./C. 100 μF 6.3WV (Vert. type)	24-12-9	1
6-32	EL390576	Pilot Lamp RM6-24V-50MA	28-2-6	4
6-33	ED224526	Silicon Diode 10D1	45-2-11	1
6-34	SB867205	Operation Button A, w/bush A(blue)	KH-2022	2
6-35	SB867565	Operation Button A, w/bush B(orange)	KH-2022	2
6-36	SB472768	Operation Button B	KH-2021	1
6-37	MS438243	Button Shaft	KF-2009	1
6-38	MZ472781	Lamp Cover	KH-2018	1
6-39	ZW270088	'E' Ring 1.9M	6-1-9	2
6-40x	ZW323728	Screw, binding head 3x5		2
6-41	MZ474513	Operation Switch Base	KH-2017	1
6-42	ES250075	Micro Switch V-1A10 U/L	25-1-8	7
6-43	MZ397337	Switch Spacer A	KD-2005	2
6-44	MZ472836	Operation Button Collar	KH-2023	2
6-45	MS250165	Micro Switch Shaft B	RD-122B	2
6-46	ZW270088	'E' Ring 1.9M	6-1-9	4
6-47	ZW417148	Screw, binding head 3x15		2
6-48	ZG466154	Switch Spring	KD-A2-012	1
6-49	ZW323728	Screw, binding head 3x5		2

FIG. 7 (A) ILLUSTRATION OF POWER SUPPLY BLOCK

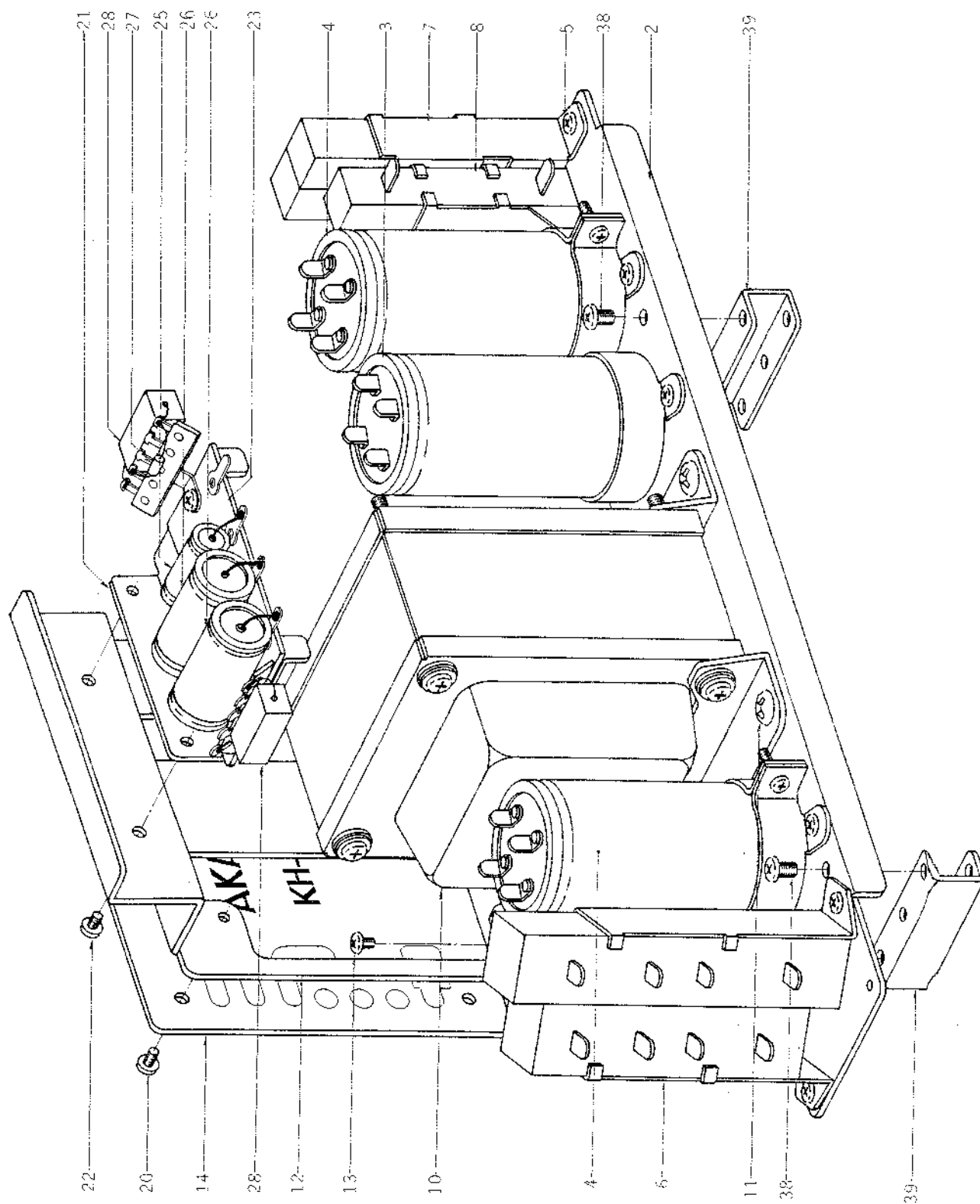
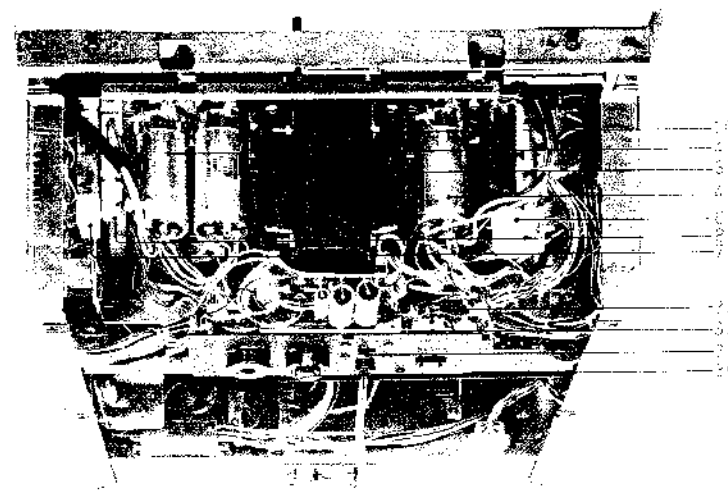
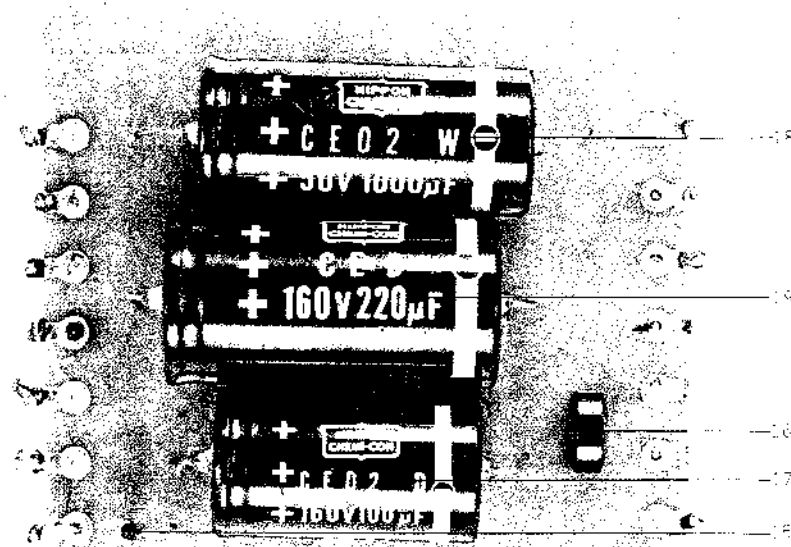


FIG. 7 (B.C) PHOTO OF POWER SUPPLY BLOCK

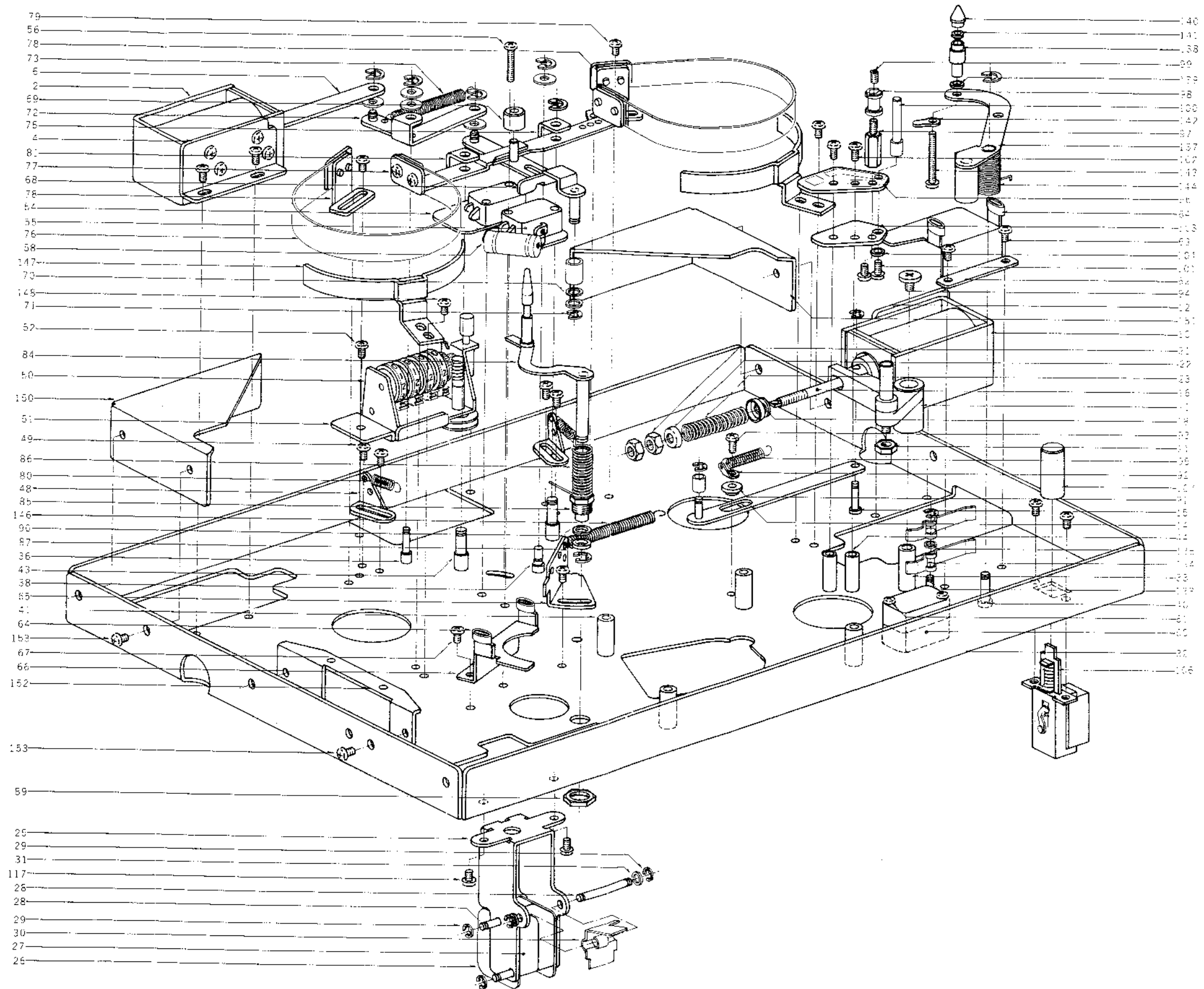


POWER SUPPLY BLOCK

Ref. No.	Parts No.	Description	Schematic No.	Qty
7-1x	BP482343	Power Supply Block Comp.	KH-2012	1
7-2	UM488924	Trans. Table	KH-2052	1
7-3	EC434081	MP/C. 3+0.5 µF 200WV (Lug type Uni.D.)	34-0-56	1
7-4	EC398632	MP/C. 3+1 µF 260WV (Lug type Uni.D.)	35-0-52	2
7-5	ZW472274	Tapping Screw #2 3x6		11
7-6	ER426690	Cement/R. H(40+30) H2B (350+150x200+500)	35-16-25	1
7-7	ER493097	Cement/R. H(20+20) H1B (60+35x1.5k+500)k	35-14-25	1
7-8	ER339805	Cement/R. H20B 450(K) (wire wound type) w/whl	35-15-16	1
7-9x	ER472296	Cement/R. H20B 220(K)	35-16-16	1
7-10	BT472702	Power Trans. KHT-1	38-4-152	1
7-11	ZW468112	Tapping Screw #2 4x8(truss)		2
7-12	MZ465772	Trans. Table D	KH-2059	1
7-13	ZW490228	Tapping Screw #2 3x8		2
7-14	BA482578	Capacitor P.C. Board (KH-2012) Comp.	KH-2051	1
7-15	ED224550	Silicon Diode 10D4	45-2-16	1
7-16	ED329130	Silicon Diode 10DC-1(black)	45-2-27	1
7-17	EC316091	Elect./C. 100 µF 160WV (Tub. type)	24-14-14	1
7-18	EC365692	Elect./C. 1000 µF 50WV (Tub. type)	24-13-12	1
7-19	EC346746	Elect./C. 220 µF 160WV (Tub. type)	24-14-8	1
7-20	ZW490228	Tapping Screw #2 3x8		4
7-21	EZ397282	Capacitor Retaining Base	KH-2007	1
7-22	ZW323728	Screw, binding head 3x5		4
7-23	EZ398946	Terminal Plate SP-0501 B type 4P	33-4-9	1
7-24x	ER430143	Carbon/R. RD1/4 120(J) (Insu. type)	35-0-2	1
7-25	EC273464	MP/C. 0.1 µF(M) 350WVDC (Tub. type)	24-0-4	1
7-26	EC341842	MP/C. 0.47 µF(M) 300WVAC (Tub. type)	24-0-55	2
7-27	EJ255115	Log Plate VB21.2	31-4-3	2
7-28	ER466986	Cement/R. S5W 45(K) (Wire-wound type)	35-16-3	2
7-29x	ED224550	Silicon Diode 10D4	45-2-16	1
7-30x	EZ328320	Nylon Clip HP 5N		2
7-31x	ZW462194	Tapping Screw #2 3x8(part) w/washer		2
7-32	EZ397304	Frequency Change Switch Plate A	31-1-203	1
7-33	ES375478	Slide Switch ESD-279DU	25-3-23	2
7-34x	ZW371856	Iso Screw, binding head 3x5		2
7-35x	ZW440291	Iso Screw, countersunk head 3x6		2
7-36	EJ233370	Power Plug Socket S-18010	40-2-3	1
7-37x	EF277413	Fuse ST-2 2A	39-1-26	1
7-38	ZW417150	Screw, pan head 4x6		4
7-39	MZ397170	Trans. Base C	KH-1065	2

When ordering parts, please describe Parts Number, Serial Number, and Model Number in detail.

FIG. 8 (A) (B) ILLUSTRATION OF MECHANISM ASSEMBLY BLOCK



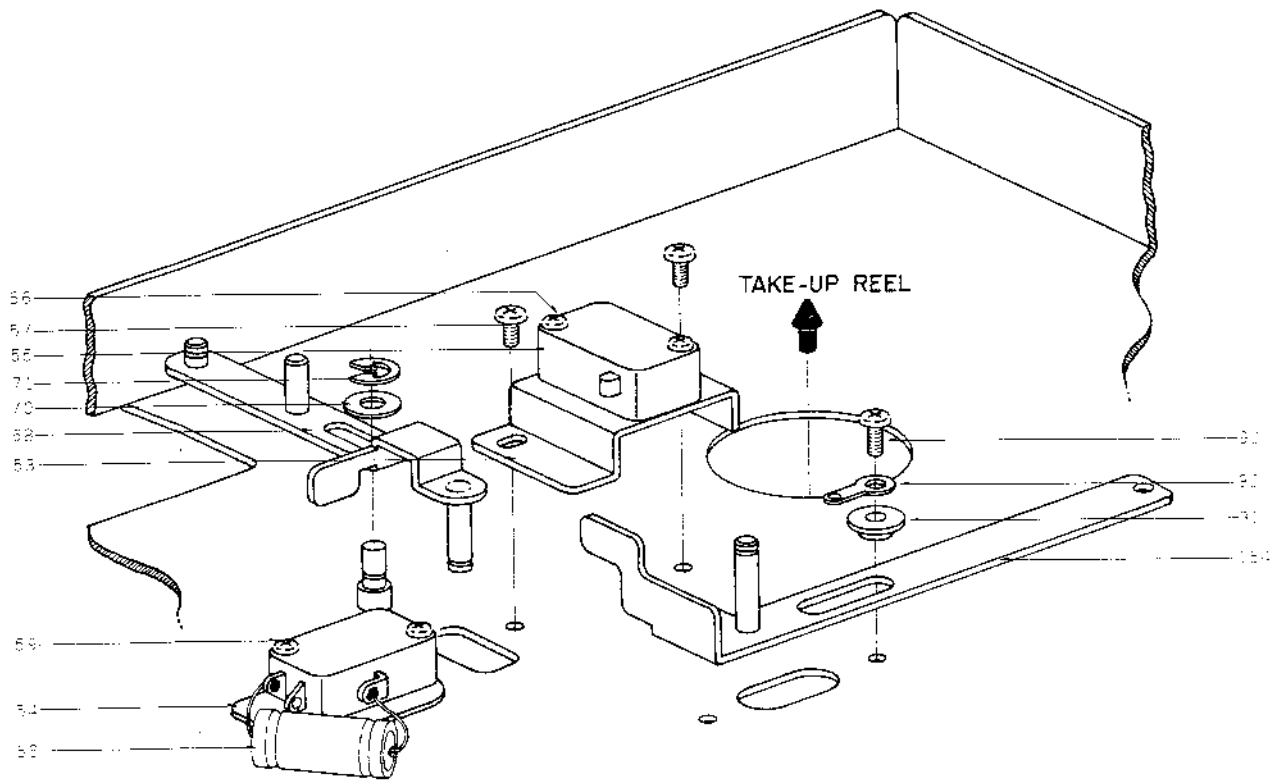
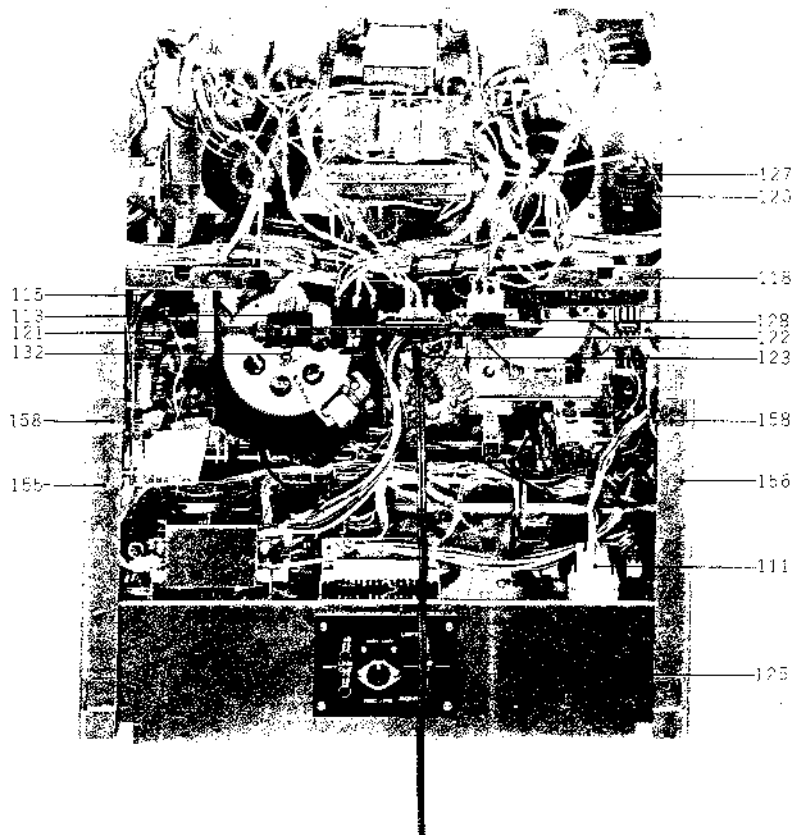


FIG. 8 (C) PHOTO OF MECHANISM ASSEMBLY BLOCK



## MECHANISM ASSEMBLY BLOCK

Ref. No.	Parts No.	Description	Schematic No.	Q'ty	Ref. No.	Parts No.	Description	Schematic No.	Q'ty
<b>BRAKE PLUNGER BLOCK</b>									
8-1x	BZ398338	Brake Plunger Block Comp.	KH-KD,KF	1	8-60	ES250064	Micro Switch V-1A44 U/L	25-1-7	2
8-2	EP398610	Plunger Solenoid			8-61	ZW414066	Screw, binding head 3x25		2
		SDC-10-M.C-100V	44-1-36	1	8-62	MZ472904	Shut-off Arm Stopper	KH-1006	1
8-3x	ER376424	Spark Quencher U/L			8-63	ZW417137	Screw, binding head 3x4		4
		0.1μ+120 500WV	41-1-36	1	8-64	MZ499634	Stopper Rubber (KH)	KH-1037	4
8-4	MZ396911	Plunger Bracket	KD-1028	1	8-65	MZ434237	KD Spring Hanger	KD-A1007	1
8-5x	ZW201835	Screw, binding head 3x5		4	8-66	MZ486450	Roller Arm Stopper	KH-1033	1
8-6	MZ396977	Brake Plunger Joint	KD-1039	1	8-67	ZW323728	Screw, binding head 3x5		2
8-7x	ZW257477	Connecting Pin	RD-211	1	8-68	MZ396832	Brake Slide, w/pin	KD-1044	1
8-8x	ZW270088	'E' Ring 1.9M	6-1-9	1	8-69	MZ397181	Lever Cushion	KD-1069	1
					8-70	ZW482545	Washer (Polystyler)		5
							D4.1x10x0.13t		
					8-71	ZW270101	'E' Ring 3M	6-1-9	1
					8-72	ML396742	Brake Lever, w/pin	KD-1041	1
8-9x	BZ482297	Pinch Roller Plunger Block			8-73	ZG465478	Brake Lever Spring	KD-1092	1
		Comp. KH,KD,K'		1	8-74x	ZW290283	'U' Ring 2.85M	6-1-1	4
8-10	EP441990	Plunger 1660TH1 Solenoid	44-1-45	1	8-75	ML314976	Brake Lever A (Take-up)	MR-310	1
8-11x	ER376424	Spark Quencher U/L			8-76	MB314987	Brake Band	MR-333	2
		0.1μ+120 500WV	41-1-36	1	8-77	MZ314998	Brake Band Retaining Plate	MR-312	4
8-12	MZ396911	Plunger Bracket	KD-1028	1	8-78	MZ315000	Brake Band Support	MR-314	2
8-13x	ZW323728	Screw, binding head 3x5		3	8-79	ZW323728	Screw, binding head 3x5		8
8-14	MZ396966	Plunger Joint, w/pin	KD-1033	1	8-80	ZG315011	Brake Lever Spring	MR-316	2
8-15	ZW257477	Connecting Pin	RD-211	1	8-81	ML396810	Brake Lever B (Supply)	KD-1038	1
8-16	MZ396944	Pinch Roller Arm Joint	RD-1031	1	8-82x	MZ467111	Servo Motor Shield	KD-11010	2
8-17x	ZW270088	'E' Ring 1.9M	6-1-9	1	8-83x	EJ254970	Lug Plate KP1L1	33-33	1
8-18	ZW345442	Washer (Nylon)D4.2x9x1t		1	8-84	ML472950	Impedance Roller Arm,		
8-19x	ZW270101	'E' Ring 3M	6-1-9	1			w/guide	KD-318	1
8-20	MZ396933	Pinch Roller Arm, w/shaft	KD-1030	1	8-85	MZ473005	Arm Shaft Metal	KH-315	1
8-21	ZW273960	M4 Nut		3	8-86	ZG472994	Tension Spring	KH-317	1
8-22	MZ802980	Spring Holder	RD-276	2	8-87	ZW472983	Z Roller Washer	MR-343	1
8-23	ZG428927	Pinch Roller Spring B	KD-1032	1	8-88x	ZW270101	'E' Ring 3M	6-1-9	1
					8-89	ZW273363	M9 Hexagon Nut	RD-34	1
					8-90	ZW499443	Washer (Nylon)D5.1x7.8x0.2t		1
					8-91	ZW397157	Graduated Washer	KD-336	1
8-24x	BS482354	Speed Change Switch Block			8-92	ZW273778	M3 Earth Lug		1
		Comp. KH,KF		1	8-93	ZW413155	Screw, binding head 3x6		1
8-25	MZ473455	Speed Change Switch Stand	KH-2010	1	8-94	ZW243516	Screw, Pinch Roller	MR-310	1
8-26	MZ402377	Micro Insulator D	KD-2050	2	8-95	ZG208091	Impedance Arm Spring	RD-39	1
8-27	ES250064	Micro Switch V-1A44 U/L	25-1-7	2	8-96	EA473016	Sensing P.C. Board	KH-313	1
8-28	MS438254	Micro Switch Shaft	KF-2023	3	8-97	MH473027	Tape Guide Prop	KD-625	1
8-29	ZW270088	'E' Ring 1.9M	6-1-9	6	8-98	MZ473038	Sensing Guide B	KH-314	1
8-30	ML397383	Speed Change Switch Lever 2	KD-2016	1	8-99	ZW433001	Set Screw, hexagon socket		
8-31	ZW425733	Washer (ALP)D3.1x8x1t		2			3x5(cup)		1
					8-100	MZ473040	Sensing Pole	KH-315	1
					8-101	ZW413741	Screw, binding head 3x8		1
					8-102	ZW413155	Screw, binding head 3x6		2
8-32	MZ472814	Mech. Frame	KD-1001	1	8-103	MZ486448	Print Reinforcement Board	KH-332	1
8-33	MS397001	Pinch Roller Arm Shaft	KD-1002	1	8-104	MZ397214	Insulator Liner A	KD-1131	1
8-34x	ZW274026	M5 Spring Washer		1	8-105x	MB303535	Counter Belt D91x1.6	3A-67	1
8-35x	ZW413278	M5 Nut		1	8-106	ES482938	Push Switch JH-3	25-5-1	1
8-36	MS397012	Brake Lever Shaft	KD-1003	1	8-107	SB474041	Push Button 2	KH-123	1
8-37x	ZW413188	M4 Nut		4	8-108x	ZW444273	Iso Screw, binding head 3x4		2
8-38	MS465480	Brake Lever Shaft B	KD-1093	1	8-109x	EJ310871	18P Multi-Jack J-2		
8-39x	ZW273756	M3 Nut		1			3250-018-001	31-4-1	1
8-40	MS397023	Tension Arm Shaft	KD-1004	1	8-110x	EJ347670	22P Multi-Jack-3		
8-41	HZ397034	Head Base Prop	KD-1005	4			3250-022-001S	31-4-3	1
8-42x	ZW416687	Screw, binding head 4x8		4	8-111	EJ450573	9P Mate-N-Lock Cap Housing		
8-43	MZ317373	Brake Lever Prop	MR-102	2			1-480277-0	52-1-	1
8-44	MH487888	Sensing Table Prop B	KH-1034	2	8-112x	HZ243191	Pin Contact 60511-1	52-1-	7
8-45x	ZW413741	Screw, binding head 3x8		8	8-113	EJ222748	Sub Magnale Socket #311SG	31-1-9	1
8-46x	MZ397045	Sys. Con. Connector Prop	KD-1006	4	8-114x	MZ302400	Remote Control Socket Mt.		
8-47x	ZW273778	M3 Earth Lug		1			Plate	RR-15	1
8-48	MZ397080	Spring Hanger	KD-1010	2	8-115	EJ368785	14P Multi-Jack 3250-014-001	31-4-4	1
8-49	ZW323728	Screw, binding head 3x5		4	8-116x	MH487890	Servo P.C. Board Prop	KH-153	2
8-50	MC399521	Counter M-470D	9-1-14	1	8-117	ZW417137	Screw, binding head 3x4		2
8-51	MZ397078	Counter Base	KD-1009	1	8-118	EZ397135	Center Frame	KD-153	1
8-52	ZW323728	Screw, binding head 3x5		2	8-119x	EZ397743	P.C. Board Prop	KD-344	3
8-53	MZ512133	Micro Switch Table	KH-2059	1	8-120	EC348704	Elect./C. 2200 μF 35WV		
8-54	MZ250413	Micro Insulator C	RC-127	2			(Lug type)	24-105	3
8-55	ES250064	Micro Switch V-1A44 U/L	25-1-7	2	8-121	MZ472858	Connector Plate	KH-344	1
8-56	ZW439514	Screw, binding head 3x18		2					
8-57	ZW323728	Screw, binding head 3x5		2	8-122	EJ378944	U/L AC Socket S-I 9122	31-1-7	1
8-58	EC273464	MP/C. 0.1μF(M) 350WVDC		1	8-123	EZ382263	Strain Relief SR-4K-4	2-7-1	1
		(Tub. type)	24-9-4	1	8-124x	EZ246936	Strain Relief SR-6W-1 (3 core)	2-7-8	1
8-59	ZW422965	Screw, pan head 3x15		2	8-125	EZ374894	U/L AC Cord 3M	26-3-	1

When ordering parts, please describe Parts Number, Serial Number, and Model Number in detail.

Ref. No.	Parts No.	Description	Schematic No.	Qty
8-126x	EZ315448	Australia Cord	26-2-21	1
8-127	EJ205975	Cramp Terminal 1-SD	32-1-7	9
8-128	EZ397124	Cycle Change Switch Plate B	KL-1055	1
8-129x	ZW201150	Screw, truss head 3x6(black)		6
8-130x	ZW374128	Iso Screw, truss head 3x8 (black)		2
8-131x	ZW447761	Tapping Screw #2 3x6(BR) (black)		4
8-132	EJ326430	11P Short Plug A	42-1-25	1
8-133	MS408497	Switch Lever Shaft	KD-1350	1
8-134	ML409083	Micro Switch Lever	KL-1081	2
8-135	ZW259683	Washer (Nylon)D3x5x1t		1
8-136x	ZW270088	'E' Ring 1.9M	6-1-9	1
8-137	ML492906	Shut-off Lever B, w/metal	KD-1032	1
8-138	MZ473073	Sensing Collar	KL-1090	1
8-139	ZW492063	Insulator Washer	KL-2056	1
8-140	MZ473051	Sensing Top	KL-1025	1
8-141	HZ317632	Insulator Collar A	MR-26	1
8-142	ZW273633	M2.3 Earth Lug		1
8-143	ZW484828	Screw, binding head 2.3x25		1
8-144	ZG409015	Tension Arm Spring C	KD-1079	1
8-145x	ZW290283	'U' Ring 2.85M	6-1-1	1
8-146	ZG407575	Shifter Lever Spring	KD-1078	1
8-147	MZ317406	Brake Band Guide, w/base	MR-120	2
8-148	ZW323728	Screw, binding head 3x5		4
8-149x	MP424023	Pinch Roller (KD)	KL-1081	1
8-150	SZ397517	Corner Angle A (left)	KD-600A	1
8-151	SZ397528	Corner Angle B (right)	KD-600B	1
8-152	SZ473725	Mech. Panel Reinforcement Plate	KL-1004	2
8-153	ZW413741	Screw, binding head 3x8		8
8-154	MZ514653	Plunger Joint B, w/pin	KD-2060	1
8-155	SZ473681	Side Chassis A, w/angle (right)	KL-1005A	1
8-156	SZ473692	Side Chassis B, w/angle (left)	KL-1005B	1
8-157x	ZW290248	U type Speed Nut M4 #1 (small)	6-3-1	6
8-158	ZW290250	U type Speed Nut M4 #1 (large)	6-3-2	10
8-159x	ZW200610	Tapping Screw 4x12(truss)		6

FIG. 9 PHOTO OF TAPE SPEED SWITCH  
P.C. BOARD (KH-2011)

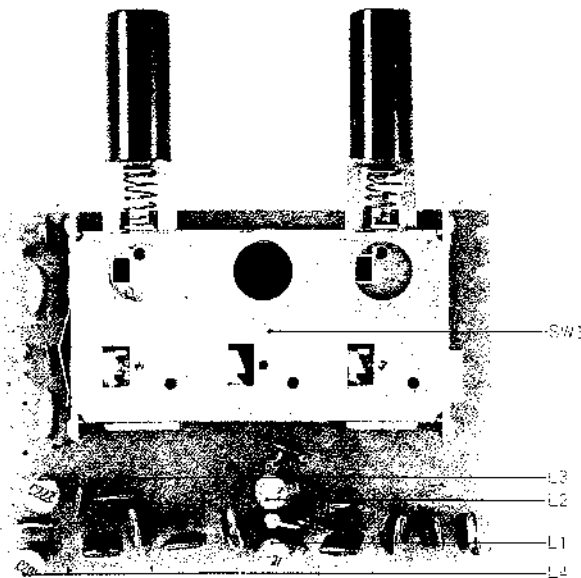
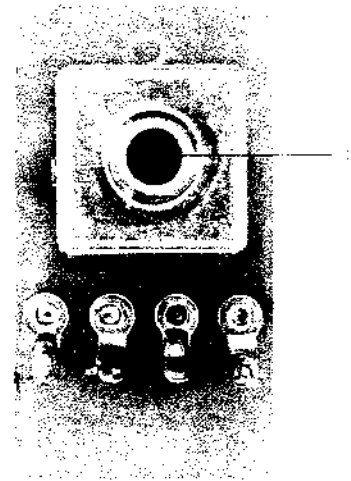


FIG. 10 PHOTO OF  
COIL P.C. BOARD (KD-1097)



TAPE SPEED SWITCH  
P.C. BOARD (KH-2011) BLOCK

Symbol No.	Parts No.	Description	Q'ty
9-1x	BA482387	Tape Speed Switch P.C. Board Comp. (KH-2011)	1
9-L1	EO243977	Ferri Inductor FL7H 1MH(J)	1
9-L2, 3	EO458932	Ferri Inductor FL7H 2.2MH(J)	2
9-L4	EO243977	Ferri Inductor FL7H 1MH(J)	1
9-SW1	ES472645	Push Switch SPM025N	1
<b>Capacitor, Vertical Type</b>			
9-C1	EC379157	Mylar 0.033 $\mu$ F(J) 50WV	1
9-C2	EC389485	Mylar 0.018 $\mu$ F(J) 50WV	1
9-C3	EC379157	Mylar 0.033 $\mu$ F(J) 50WV	1
9-C4	EC368335	Mylar 0.022 $\mu$ F(J) 50WV	1
9-C5	EC250975	Mylar 0.015 $\mu$ F(J) 50WV	1
9-C6	EC411827	Mylar 0.0082 $\mu$ F(J) 50WV	1
9-C7	EC379157	Mylar 0.033 $\mu$ F(J) 50WV	1
9-C8	EC389485	Mylar 0.018 $\mu$ F(J) 50WV	1
9-C9	EC379192	Mylar 0.039 $\mu$ F(J) 50WV	1
9-C10	EC250975	Mylar 0.015 $\mu$ F(J) 50WV	1
9-C11	EC368335	Mylar 0.022 $\mu$ F(J) 50WV	1
9-C12	EC350875	Mylar 0.001 $\mu$ F(J) 50WV	1
9-C13	EC329848	Hi-Q 100PF(J) 50WV	1
9-C14	EC350875	Mylar 0.001 $\mu$ F(J) 50WV	1
9-C15	EC329848	Hi-Q 100PF(J) 50WV	1
9-C16	EC411827	Mylar 0.0082 $\mu$ F(J) 50WV	1
<b>Resistor, Stepper Type</b>			
9-R1	ER362441	Carbon RD1/4 1.8k(J)	1
9-R2	ER399060	Carbon RD1/4 9.1k(J)	1
9-R4	ER399060	Carbon RD1/4 9.1k(J)	1
9-R6	ER362441	Carbon RD1/4 1.8k(J)	1

COIL P.C. BOARD (KD-1097) BLOCK

Symbol No.	Parts No.	Description	Q'ty
10-1x	BA495808	Coil P.C. Board Comp. (KD-1097)	1
10-L1	EO403446	Variable Coil VI2031 SC-01	1
10-2x	EZ495843	Coil Retaining Angle	1
10-3x	ZW413155	Screw, binding head 3x6	2



FIG. 11 PHOTO OF SERVO P.C. BOARD (KH-1011)

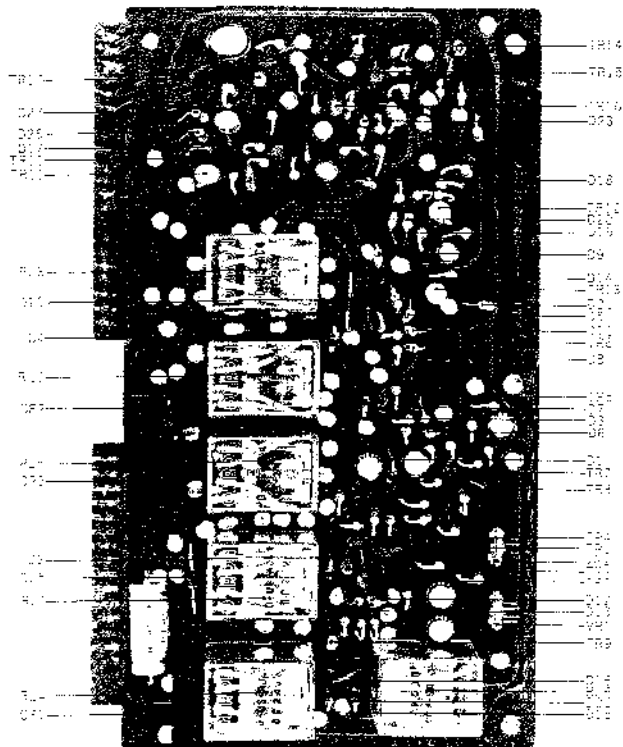


SERVO P.C. BOARD (KH-1011) BLOCK

Symbol No.	Parts No.	Description	Q'ty	Symbol No.	Parts No.	Description	Q'ty
11-1x	BA482332	Servo P.C. Board Comp. (KH-1011)	1	11-C210	EC424080	Styrol 0.051 $\mu$ F(F) 50WV	1
11-TR201	ET379462	Transistor 2SC711(D)(E)	1	11-C211	EC438524	Mylar 0.27 $\mu$ F(H) 100WV	1
11-TR202	ET356984	Transistor 2SA564(R)	1	11-C213	EC220994	Elect. 10 $\mu$ F 25WV	1
11-TR203, 4	ET379462	Transistor 2SC711(D)(E)	2	11-C215	EC368280	Solid Aluminum 33 $\mu$ F 6.3WV	1
11-TR205	ET356984	Transistor 2SA564(R)	1	11-C216	EC220131	Elect. 100 $\mu$ F 25WV	1
11-TR206	ET398777	Transistor 2SC711(G)(F)	1	11-C251, 2	EC403468	Elect. 330 $\mu$ F 50WV	2
11-TR207	ET379462	Transistor 2SC711(D)(E)	1	11-C253	EC372148	Elect. 220 $\mu$ F 35WV	1
11-TR208	ET399936	Transistor 2SC945(R)(S)	1	11-C254	EC331817	Elect. 470 $\mu$ F 25WV	1
11-TR209	ET403042	Transistor 2SD234(Y)	1	11-C255	EC350684	Elect. 22 $\mu$ F 25WV	1
11-TR251	ET408971	Transistor 2SC1013	1	11-C257	EC450281	Elect. 0.47 $\mu$ F 50WV	1
11-TR252	ET403042	Transistor 2SD234(Y)	1			<b>Resistor, Stopper Type</b>	
11-TR253	ET391138	Transistor 2SC968(3)(4)	1	11-R201	ER336442	Carbon RD1/4 10k(J)	1
11-D201, 2	ED224526	Silicon Diode 10D1	2	11-R202	ER362441	Carbon RD1/4 1.8k(J)	1
11-D204	ED224526	Silicon Diode 10D1	1	11-R203	ER357456	Carbon RD1/4 2.2k(J)	1
11-D251	ED329130	Silicon Diode 10DC-1(black)	1	11-R204	ER212264	Carbon RD1/4 22k(J)	1
11-D252	ED329128	Silicon Diode 10DC-1(red)	1	11-R205, 6, 7	ER336442	Carbon RD1/4 10k(J)	3
11-D253	ED384096	Zener Diode RD-9A	1	11-R208	ER361642	Carbon RD1/4 47(J)	1
11-TH201	ED321390	Thermistor 41D26	1	11-R209	ER211757	Carbon RD1/4 100k(J)	1
11-VR202	EV498060	Semi-fixed Volume V10K8-1-5 2k B(4US)	1	11-R210	ER357456	Carbon RD1/4 2.2k(J)	1
11-VR251	EV484863	Semi-fixed Volume V10K8-4-2 1k B	1	11-R211	ER212631	Carbon RD1/4 330(J)	1
11-2	EZ407586	Heat-sink Plate B	1	11-R212	ER403187	Carbon RD1/4 10k(F)(J type)	1
11-3	ZW392940	Insulator Washer 1 G-473025-1	2	11-R213	ER403097	Carbon RD1/4P 9.1k(J) (J type)	1
11-4	ZW421806	Screw, pan head 3x8	2	11-R214	ER212883	Carbon RD1/4 4.7k(J)	1
11-5	ZW273756	M3 Nut	4	11-R217	ER306887	Carbon RD1/4 15k(J)	1
11-6	EZ474017	Heat-sink Plate	1	11-R218	ER212883	Carbon RD1/4 4.7k(J)	1
11-7x	ZW413155	Screw, binding head 3x6	2	11-R219	ER357456	Carbon RD1/4 2.2k(J)	1
11-8	ZW413741	Screw, binding head 3x8	2	11-R220	ER211667	Carbon RD1/4 100(J)	1
11-9x	ZW273802	M3 Toothed Lock Washer	1	11-R221	ER213030	Carbon RD1/4 5.6k(J)	1
11-10x	EZ473400	Servo P.C. Board Collar	2	11-R222, 3	ER357456	Carbon RD1/4 2.2k(J)	2
11-11x	ZW413155	Screw, binding head 3x6	2	11-R224, 5	ER211465	Carbon RD1/4 1k(J)	2
		<b>Capacitor, Vertical Type</b>		11-R226	ER304290	Carbon RD1/4 10(J)	1
11-C201	EC398957	Mylar 0.1 $\mu$ F(M) 50WV	1	11-R227	ER306887	Carbon RD1/4 15k(J)	1
11-C202	EC251190	Mylar 0.056 $\mu$ F(K) 50WV	1	11-R228	ER424078	Carbon RD1/4 51(J)	1
11-C203	EC331705	Elect. 22 $\mu$ F 16WV	1	11-R229	ER304402	Carbon RD1/4 470(J)	1
11-C204	EC379787	Mylar 0.0039 $\mu$ F(J) 50WV	1	11-R251	ER357456	Carbon RD1/4 2.2k(J)	1
11-C205	EC320051	Elect. 10 $\mu$ F 16WV	1	11-R252	ER212631	Carbon RD1/4 330(J)	1
11-C206	EC250661	Mylar 0.0015 $\mu$ F(K) 50WV	1	11-R253	ER343078	Carbon RD1/4 2.7k(J)	1
11-C207	EC220151	Elect. 100 $\mu$ F 25WV	1	11-R254	ER357456	Carbon RD1/4 2.2k(J)	1
11-C208	EC350684	Elect. 22 $\mu$ F 25WV	1	11-R255	ER306843	Carbon RD1/4 1.2k(J)	1
11-C209	EC329850	VFM 220PF(J) 50WV	1	11-R256	ER447682	Solid RC1/2 47(J)	1
				11-R257	ER347038	Carbon RD1/4 270(J)	1

When ordering parts, please describe Parts Number, Serial Number, and Model Number in detail.

FIG. 12 (A) PHOTO OF  
SYS. CON. P.C. BOARD (KH-1009)



Symbol No.	Parts No.	Description	Q'ty
<b>Capacitor, Vertical Type</b>			
12-C1 to 4	EC220612	Elect. 33 $\mu$ F 25WV	4
12-C5	EC350684	Elect. 22 $\mu$ F 25WV	1
12-C6	EC220994	Elect. 10 $\mu$ F 25WV	1
12-C7	EC308711	Mylar 0.047 $\mu$ F(K) 50WV	1
12-C8	EC220994	Elect. 10 $\mu$ F 25WV	1
12-C10, 11	EC220994	Elect. 10 $\mu$ F 25WV	2
12-C12, 3, 4	EC450055	Elect. 1 $\mu$ F 25WV	3
12-C16	EC273464	MP 0.1 $\mu$ F(M) 350WVDC (Tub. type)	1
12-C17	EC220432	Elect. 2.2 $\mu$ F 25WV	1
12-C19	EC220151	Elect. 100 $\mu$ F 25WV	1
12-C20	EC250885	Mylar 0.01 $\mu$ F(K) 50WV	1

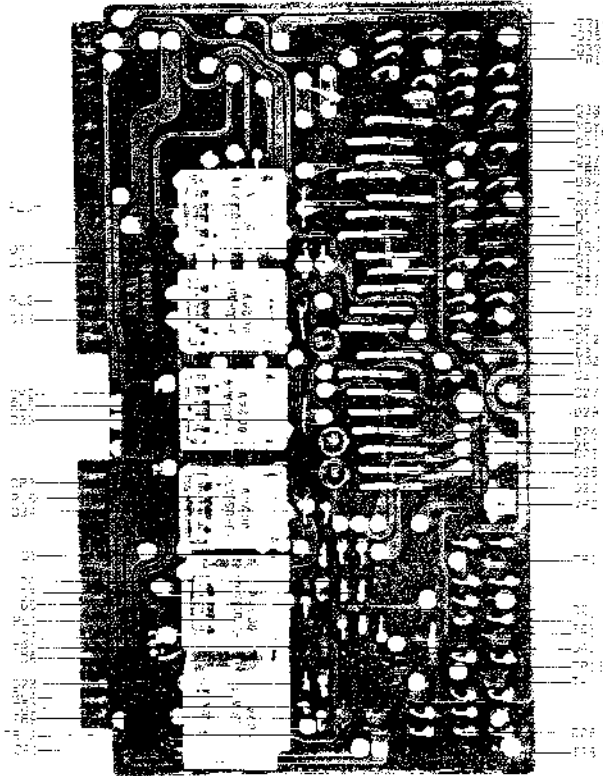
Symbol No.	Parts No.	Description	Q'ty
<b>Resistor, Stopper Type</b>			
12-R1	ER211465	Carbon RD1/4 1k(J)	1
12-R2	FR362485	Carbon RD1/4 330k(J)	1
12-R3	ER336442	Carbon RD1/4 10k(J)	1
12-R4, 5	ER212883	Carbon RD1/4 4.7k(J)	2
12-R6	ER362485	Carbon RD1/4 330k(J)	1
12-R7	ER212883	Carbon RD1/4 4.7k(J)	1
12-R8	ER211465	Carbon RD1/4 1k(J)	1
12-R9	FR212883	Carbon RD1/4 4.7k(J)	1
12-R10	ER357456	Carbon RD1/4 2.2k(J)	1
12-R11	FR343078	Carbon RD1/4 2.7k(J)	1
12-R12	FR212883	Carbon RD1/4 4.7k(J)	1
12-R13	ER357456	Carbon RD1/4 2.2k(J)	1
12-R14	FR343078	Carbon RD1/4 2.7k(J)	1
12-R15, 6	ER357535	Carbon RD1/4 39k(J)	2
12-R17	ER212264	Carbon RD1/4 22k(J)	1
12-R18	ER212883	Carbon RD1/4 4.7k(J)	1
12-R19	FR212264	Carbon RD1/4 22k(J)	1
12-R20, 1	ER362485	Carbon RD1/4 330k(J)	2
12-R22, 3	ER357535	Carbon RD1/4 39k(J)	2
12-R24, 5	ER212883	Carbon RD1/4 4.7k(J)	2
12-R26	ER357456	Carbon RD1/4 2.2k(J)	1
12-R27	FR343078	Carbon RD1/4 2.7k(J)	1
12-R28, 9	FR391623	Metal Oxide Film 1W 1k(K)	2
12-R30	ER357456	Carbon RD1/4 2.2k(J)	1
12-R31	ER213300	Carbon RD1/4 680(J)	1
12-R32	ER306843	Carbon RD1/4 1.2k(J)	1
12-R33	ER213300	Carbon RD1/4 680(J)	1
12-R34	ER211667	Carbon RD1/4 100(J)	1
12-R35, 6	ER212883	Carbon RD1/4 4.7k(J)	2
12-R37, 8	FR213030	Carbon RD1/4 5.6k(J)	2
12-R39	ER357412	Carbon RD1/4 220(J)	1
12-R40	ER212883	Carbon RD1/4 4.7k(J)	1
12-R41	ER211465	Carbon RD1/4 1k(J)	1
12-R42	FR213030	Carbon RD1/4 5.6k(J)	1
12-R43	ER211465	Carbon RD1/4 1k(J)	1
12-R44	FR212264	Carbon RD1/4 22k(J)	1
12-R45	FR343078	Carbon RD1/4 2.7k(J)	1
12-R46	ER212883	Carbon RD1/4 4.7k(J)	1
12-R47, 8, 9	ER212264	Carbon RD1/4 22k(J)	3
12-R50, 1	ER212883	Carbon RD1/4 4.7k(J)	2
12-R52, 3	ER212264	Carbon RD1/4 22k(J)	2
12-R54	ER212883	Carbon RD1/4 4.7k(J)	1
12-R55	FR346601	Carbon RD1/4 4.7k(J)	1
12-R56, 7	FR212264	Carbon RD1/4 22k(J)	2
12-R58	FR493110	Carbon RD1/4 2.2k(J)	1

**SYS. CON. P.C. BOARD (KH-1009) BLOCK**

Symbol No.	Parts No.	Description	Q'ty
12-1x	BA482365	Sys. Con. P.C. Board Comp. (KH-1009)	1
12-TR1 to 10	FT398711	Transistor 2SC945(Q)(R)	10
12-TR11 to 13	ET338894	Transistor 2SC968(3)	3
12-TR14 to 17	ET398711	Transistor 2SC945(Q)(R)	4
12-D1 to 4	ED224526	Silicon Diode 10D1	4
12-D5 to 9	ED219464	Germanium Diode 1N34A	5
12-D10	ED224526	Silicon Diode 10D1	1
12-D11 to 14	ED219464	Germanium Diode 1N34A	4
12-D15 to 17	ED224526	Silicon Diode 10D1	3
12-D18 to 21	ED219464	Germanium Diode 1N34A	4
12-D22	ED224526	Silicon Diode 10D1	1
12-D23	ED219464	Germanium Diode 1N34A	1
12-D25	ED224550	Silicon Diode 10D4	1
12-D26, 7	ED219464	Germanium Diode 1N34A	2
12-R11 to 6	EP344136	Relay MY4-0-US-AD4-24V	6
12-CR1 to 3	ER376424	Spark Quencher U/L 0.1 $\mu$ +120 500WV	3
12-VR1	EV426936	Semi-fixed Volume V10K-5 30k B	1
12-VR2	EV221826	Semi-fixed Volume V10K-5 10k B	1

When ordering parts, please describe Parts Number, Serial Number, and Model Number in detail.

FIG. 12 (B) PHOTO OF  
SYS. CON. P.C. BOARD (KH-1039)



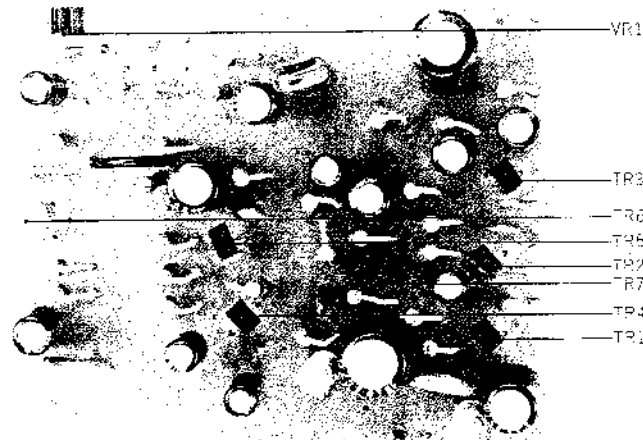
Symbol No.	Parts No.	Description	Qty
		Capacitor, Vertical Type	
12-C1, 2	EC450527	Elect. 4.7 $\mu$ F 25WV	2
12-C3 to 5	EC456041	Elect. 33 $\mu$ F 25WV	3
12-C6	EC273464	MP 0.1 $\mu$ F (M) 350WVDC (Tubular type)	1
12-C7 to 10	EC220432	Elect. 2.2 $\mu$ F 25WV	4
12-C11	EC220994	Elect. 10 $\mu$ F 25WV	1
12-C12	EC336126	Elect. 47 $\mu$ F 25WV	1
12-C13	EC251190	Mylar 0.056 $\mu$ F (K) 50W V	1
12-C14	EC251087	Mylar 0.022 $\mu$ F (K) 50W V	1

SYS. CON. P.C. BOARD (KH-1039) BLOCK

Symbol No.	Parts No.	Description	Qty
12-2X	BA515520	Sys. Con. P.C. Board (KH-1039)	1
12-TR1	ET515722	Transistor 2SC711 (D)(E)(F)	1
12-TR2	ET515700	Transistor 2SA628 (D)(E)(F)	1
12-TR3	ET515722	Transistor 2SC711 (D)(E)(F)	1
12-TR4	ET515733	Transistor 2SC945 (P)(Q)(R)(S)	1
12-TR5	ET515722	Transistor 2SC711 (D)(E)(F)	1
12-TR6	ET515733	Transistor 2SC945 (P)(Q)(R)(S)	1
12-TR7, 8	ET515722	Transistor 2SC711 (D)(E)(F)	2
12-TR9	ET515700	Transistor 2SA628 (D)(E)(F)	1
12-TR10, 11	ET515722	Transistor 2SC711 (D)(E)(F)	2
12-TR12	ET515700	Transistor 2SA628 (D)(E)(F)	1
12-TR13	ET515880	Transistor 2SA696 (C)(D)	1
12-TR14	ET515722	Transistor 2SC711 (D)(E)(F)	1
12-TR15	ET515700	Transistor 2SA628 (D)(E)(F)	1
12-TR16	ET515722	Transistor 2SC711 (D)(E)(F)	1
12-D1 to 4	ED514721	Silicon Diode WG-599	4
12-D5	ED224526	Silicon Diode 10D1	1
12-D6, 7	ED224550	Silicon Diode 10D4	2
12-D8 to 12	ED514721	Silicon Diode WG-599	5
12-D13	ED224526	Silicon Diode 10D1	1
12-D14 to 19	ED514721	Silicon Diode WG-599	6
12-D20	ED224526	Silicon Diode 10D1	1
12-D21 to 27	ED514721	Silicon Diode WG-599	7
12-D28	ED224526	Silicon Diode 10D1	1
12-D29 to 32	ED514721	Silicon Diode WG-599	4
12-D33, 34	ED224526	Silicon Diode 10D1	2
12-D35 to 42	ED514721	Silicon Diode WG-599	8
12-RL1 to 6	EP344136	Relay MY4-O-US-AD4-24V	6
12-CR1 to 3	ER376424	Spark Quencher 0.1 $\mu$ +120 500WV	3
12-VR1, 2	EV513562	Semi-fixed Volume V10K8-1.5 100k B 4US	2

Symbol No.	Parts No.	Description	Qty
		Resistor, Stopper Type	
12-R1	ER211757	Carbon RD1/4 100k (I)	1
12-R2, 3	ER320207	Carbon RD1/4 47k (J)	2
12-R4	ER211465	Carbon RD1/4 1k (J)	1
12-R5, 6, 7	ER212883	Carbon RD1/4 4.7k (J)	3
12-R8	ER429996	Carbon RD1/4 470k (J)	1
12-R9	ER346601	Carbon RD1/4 47k (J)	1
12-R10 to 12	ER212883	Carbon RD1/4 4.7k (J)	3
12-R13	ER211465	Carbon RD1/4 1k (J)	1
12-R14	ER336442	Carbon RD1/4 10k (J)	1
12-R15	ER212883	Carbon RD1/4 4.7k (J)	1
12-R16	ER211465	Carbon RD1/4 1k (J)	1
12-R17, 8	ER212883	Carbon RD1/4 4.7k (J)	2
12-R19	ER211465	Carbon RD1/4 1k (J)	1
12-R20	ER336442	Carbon RD1/4 10k (J)	1
12-R21	ER212883	Carbon RD1/4 4.7k (J)	1
12-R22	ER211465	Carbon RD1/4 1k (J)	1
12-R23, 4	ER212883	Carbon RD1/4 4.7k (J)	2
12-R25	ER211465	Carbon RD1/4 1k (J)	1
12-R26	ER336442	Carbon RD1/4 10k (J)	1
12-R27	ER212883	Carbon RD1/4 4.7k (J)	1
12-R28	ER211465	Carbon RD1/4 1k (J)	1
12-R29 to 31	ER212883	Carbon RD1/4 4.7k (J)	3
12-R32	ER211465	Carbon RD1/4 1k (J)	1
12-R33	ER336442	Carbon RD1/4 10k (J)	1
12-R34	ER212883	Carbon RD1/4 4.7k (J)	1
12-R35	ER211465	Carbon RD1/4 1k (J)	1
12-R36	ER304290	Carbon RD1/4 10 (J)	1
12-R37	ER336442	Carbon RD1/4 10k (J)	1
12-R38	ER399723	Carbon RD1/4 4.7k (J)	1
12-R39, 40	ER212883	Carbon RD1/4 4.7k (J)	2
12-R41	ER211465	Carbon RD1/4 1k (J)	1
12-R43	ER336442	Carbon RD1/4 10k (J)	1
12-R44	ER212883	Carbon RD1/4 4.7k (J)	1
12-R45	ER346601	Carbon RD1/4 47k (J)	1
12-R46, 7	ER211465	Carbon RD1/4 1k (J)	2
12-R48	ER336442	Carbon RD1/4 10k (J)	1

FIG. 13 PHOTO OF REC. AMP. P.C. BOARD (KH-5013)

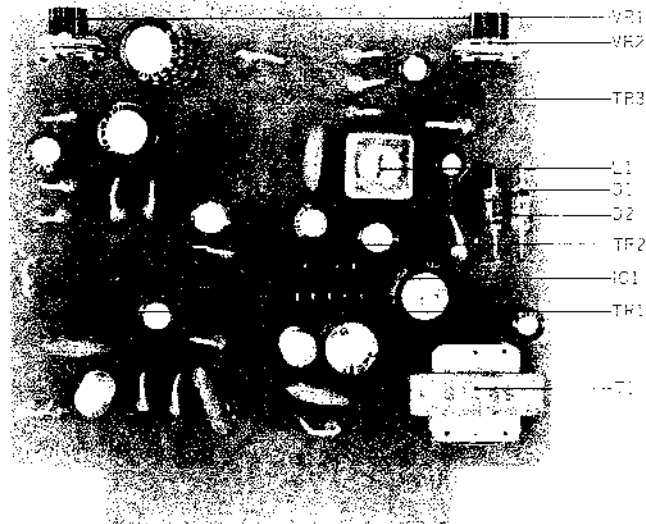


REC. AMP. P.C. BOARD (KH-5013) BLOCK

Symbol No.	Parts No.	Description	Q'ty	Symbol No.	Parts No.	Description	Q'ty
13-1x	BA482490	Rec. Amp. P.C. Board Comp. (KH-5013)	1	<b>Resistor, Stopper Type</b>			
13-TR1, 2	ET234843	Transistor 2SC458LG(B)(C)	2	13-R1	ER336442	Carbon RD1/4 10k(J)	1
13-TR3	ET329242	Transistor 2SC454(C)	1	13-R2, 3	ER383758	Carbon RD1/4 180k(J)(noiseless)	2
13-TR4	ET234843	Transistor 2SC458LG(B)(C)	1	13-R4	ER349942	Carbon RD1/4 8.2k(J)	1
13-TR5	ET329242	Transistor 2SC454(C)	1	13-R5	ER212681	Carbon RD1/4 330(J)	1
13-TR6	ET338894	Transistor 2SC968(3)	1	13-R6	ER342933	Carbon RD1/4 27k(J)	1
13-TR7	ET234832	Transistor 2SC458LG(B)	1	13-R7, 8	ER346994	Carbon RD1/4 18k(J)	2
13-VR1	EV221826	Semi-fixed Volume V10K-5 10k B	1	13-R9, 10	ER212477	Carbon RD1/4 3.3k(J)	2
<b>Capacitor, Vertical Type</b>				13-R11	ER336442	Carbon RD1/4 10k(J)	1
13-C1	EC220612	Elect. 33 $\mu$ F 25WV	1	13-R12	ER383758	Carbon RD1/4 180k(J) (noiseless)	1
13-C2	EC432810	Elect. 10 $\mu$ F 16WV(noiseless)	1	13-R13	ER346601	Carbon RD1/4 47k(J)	1
13-C3	EC290586	VFM 470PF(K) 50WV	1	13-R14	ER211858	Carbon RD1/4 12k(J)	1
13-C4	EC220465	Elect. 22 $\mu$ F 6.3WV	1	13-R15	ER211465	Carbon RD1/4 1k(J)	1
13-C5	EC487394	VFM 47PF(K) 50WV	1	13-R16	ER352045	Carbon RD1/4 3.9k(J)	1
13-C6	EC329771	Elect. 47 $\mu$ F 6.3WV	1	13-R17, 8	ER213030	Carbon RD1/4 5.6k(J)	2
13-C7	EC350684	Elect. 22 $\mu$ F 25WV	1	13-R19	ER450011	Carbon RD1/4 120k(J)	1
13-C8	EC220678	Elect. 47 $\mu$ F 25WV	1	13-R20	ER213467	Carbon RD1/4 820(J)	1
13-C9	EC432810	Elect. 10 $\mu$ F 16WV(noiseless)	1	13-R21	ER211757	Carbon RD1/4 100k(J)	1
13-C10	EC250604	Mylar 0.001 $\mu$ F(K) 50WV	1	13-R23	ER352045	Carbon RD1/4 3.9k(J)	1
13-C11	EC220994	Elect. 10 $\mu$ F 25WV	1	13-R24	ER362441	Carbon RD1/4 1.8k(J)	1
13-C12	EC220465	Elect. 22 $\mu$ F 6.3WV	1	13-R25	ER363644	Carbon RD1/4 560(J)	1
13-C13	EC220151	Elect. 100 $\mu$ F 25WV	1	13-R26	ER342933	Carbon RD1/4 27k(J)	1
13-C14	EC320051	Elect. 10 $\mu$ F 16WV	1	13-R27	ER361528	Carbon RD1/4 56k(J)	1
13-C16	EC220465	Elect. 22 $\mu$ F 6.3WV	1	13-R28	ER212264	Carbon RD1/4 22k(J)	1
13-C17	EC487394	VFM 47PF(K) 50WV	1	13-R29	ER380755	Carbon RD1/4 6.2k(J)	1
13-C18	EC320040	Elect. 47 $\mu$ F 16WV	1	13-R30	ER212681	Carbon RD1/4 330(J)	1
13-C19	EC302253	Mylar 0.15 $\mu$ F(K) 50WV	1	13-R31	ER211858	Carbon RD1/4 12k(J)	1
13-C20	EC220994	Elect. 10 $\mu$ F 25WV	1	13-R32	ER352045	Carbon RD1/4 3.9k(J)	1
13-C23	EC320051	Elect. 10 $\mu$ F 16WV	1	13-R33	ER211465	Carbon RD1/4 1k(J)	1
13-C24	EC220994	Elect. 10 $\mu$ F 25WV	1	13-R34	ER349784	Carbon RD1/4 390(J)	1
13-C25	EC423562	VFM 470PF(J) 50WV	1	13-R35	ER212477	Carbon RD1/4 3.3k(J)	1

When ordering parts, please describe Parts Number, Serial Number, and Model Number in detail.

FIG. 14 PHOTO OF P.B. AMP. P.C. BOARD (KH-5014)



**P.B. AMP. P.C. BOARD (KH-5014) BLOCK**

Symbol No.	Parts No.	Description	Q'ty	Symbol No.	Parts No.	Description	Q'ty
14-1x	BA482501	P.B. Amp. P.C. Board Comp. (KH-5014)	1	14-C15	EC290564	VFM 220PF(K) 50WV	1
14-IC1	E1412413	Line Amp. I.C. LD-3141	1	14-C16	EC220364	Elect. 100 $\mu$ F 6.3WV	1
14-TR1, 2	ET399868	Transistor 2SC871(F)	2	14-C17	EC220994	Elect. 10 $\mu$ F 25WV	1
14-TR3	ET398711	Transistor 2SC945(Q)(R)	1	14-C18	EC450055	Elect. 1 $\mu$ F 25WV	1
14-D1, 2	ED219464	Germanium Diode 1N34A	2	14-C19	EC320051	Elect. 10 $\mu$ F 16WV	1
14-T1	BT247768	Head Phone Trans. N19-5921S	1	14-C20	EC450055	Elect. 1 $\mu$ F 25WV	1
14-L1	EO262484	DM Coil 10MH	1	<b>Resistor, Stopper Type</b>			
14-VR1	EV221850	Semi-fixed Volume V10K-5 20k B	1	14-R1, 2	ER427083	Carbon RD1/4 330k(J)(noiseless)	2
14-VR2	EV398812	Semi-fixed Volume V10K-5 5k B	1	14-R3	ER336442	Carbon RD1/4 10k(J)	1
<b>Capacitor, Vertical Type</b>				14-R4	ER212681	Carbon RD1/4 330(J)	1
14-C1	EC432810	Elect. 10 $\mu$ F 16WV(noiseless)	1	14-R5	ER357570	Carbon RD1/4 150k(J)	1
14-C2	EC220678	Elect. 47 $\mu$ F 25WV	1	14-R6	ER342933	Carbon RD1/4 27k(J)	1
14-C3	EC290586	VFM 470PF(K) 50WV	1	14-R7	ER212883	Carbon RD1/4 4.7k(J)	1
14-C4	EC329771	Elect. 47 $\mu$ F 6.3WV	1	14-R8	ER212477	Carbon RD1/4 3.3k(J)	1
14-C5	EC377212	VFM 47PF(J) 50WV	1	14-R9	ER336442	Carbon RD1/4 10k(J)	1
14-C6	EC329771	Elect. 47 $\mu$ F 6.3WV	1	14-R10	ER380711	Carbon RD1/4 220k(J)	1
14-C7	EC429851	VFM 680PF(J) 50WV	1	14-R11	ER349907	Carbon RD1/4 33k(J)	1
14-C8	EC250841	Mylar 0.01 $\mu$ F(J) 50WV	1	14-R12	ER212883	Carbon RD1/4 4.7k(J)	1
14-C9	EC220994	Elect. 10 $\mu$ F 25WV	1	14-R13	ER304402	Carbon RD1/4 470(J)	1
14-C10, 1	EC220151	Elect. 100 $\mu$ F 25WV	2	14-R14	ER336442	Carbon RD1/4 10k(J)	1
14-C12	EC432810	Elect. 10 $\mu$ F 16WV(noiseless)	1	14-R15	ER212264	Carbon RD1/4 22k(J)	1
14-C13	EC290564	VFM 220PF(K) 50WV	1	14-R16	ER429996	Carbon RD1/4 470k(J)	1
14-C14	EC329771	Elect. 47 $\mu$ F 6.3WV	1	14-R17, 8	ER357456	Carbon RD1/4 2.2k(J)	2

FIG. 15 PHOTO OF  
OSC. P.C. BOARD (KH-5015)

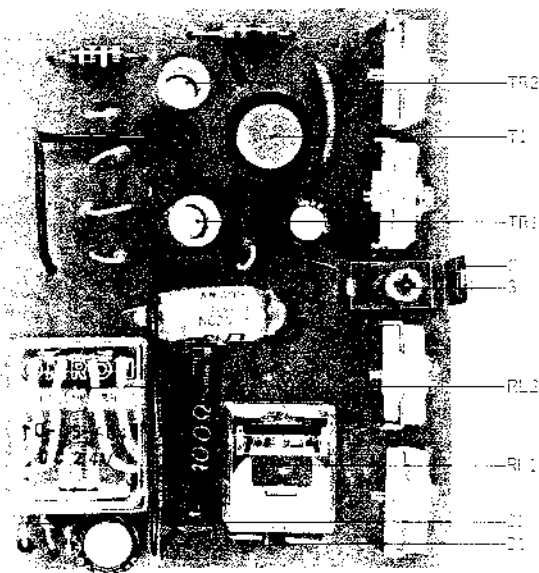
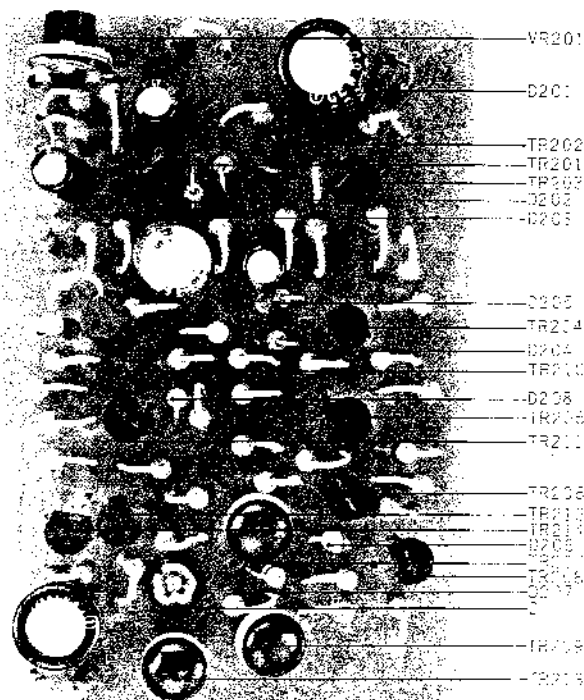


FIG. 16 PHOTO OF COM DETECTOR  
P.C. BOARD (RD-A514)



**OSC. P.C. BOARD (KH-5015) BLOCK**

Symbol No.	Parts No.	Description	Q'ty
15-1x	BA482512	OSC. P.C. Board Comp. (KH-5015)	1
15-TR1, 2	ET304255	Transistor 2SC971(2)(3)(red)	2
15-T1	EO383365	OSC. Coil OT-204	1
15-D1, 2	ED224526	Silicon Diode 10D1	2
15-RL1	EP383321	Relay TECK-36 DC22V 1000	1
15-RL2	EP344136	Relay MY4-O-US-AD)4-24V	1
15-2	EZ425226	P.C. Board Retaining Metal	1
15-3	ZW413155	Screw, binding head 3x6	1
15-4x	ZW273756	M3 Nut	1
<b>Capacitor, Vertical Type</b>			
15-C1	EC350684	Elect. 22 $\mu$ F 25WV	1
15-C2, 3	EC250841	Mylar 0.01 $\mu$ F(J) 50WV	2
15-C4	EC442080	Plustic Film 4500PF(J) 500WV	1
15-C5 to 8	EC425250	Trimmer A-1P3-3 70PF	4
15-C9	EC220151	Elect. 100 $\mu$ F 25WV	1
<b>Resistor, Stopper Type</b>			
15-R1	ER426892	Solid RC1/2W 2.4k(J)	1
15-R2	ER251684	Wire-wound 2WL 100(K) (L type)	1
15-R3, 4	FR315944	Carbon RD1/4 3.3(J)	2
15-R5	ER212883	Carbon RD1/4 4.7k(J)	1
15-R6	ER304402	Carbon RD1/4 470(J)	1
15-R7	ER455848	Solid RC1/2W 27(J)	1
15-R8	FR347038	Carbon RD1/4 270(J)	1
15-R9	ER211667	Carbon RD1/4 100(J)	1
15-R10	ER361642	Carbon RD1/4 47(J)	1

**COM DETECTOR**

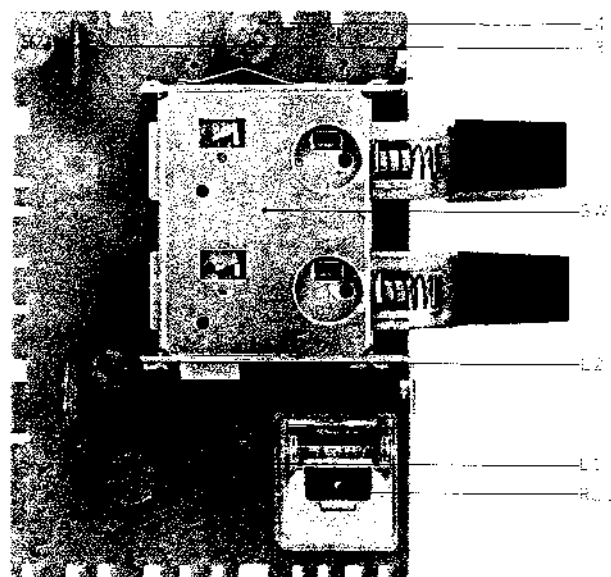
**P.C. BOARD (RD-A514) BLOCK**

Symbol No.	Parts No.	Description	Q'ty
16-1x	BA482523	COM Detector P.C. Board Comp. (RD-A514)	1
16-TR201	ET380834	Transistor 2SC711(E)	1
16-TR202,3,4	ET371935	Transistor 2SC711(D)	3
16-TR205, 6	ET380834	Transistor 2SC711(E)	2
16-TR207	ET383466	Transistor CDC9000-1(B)	1
16-TR208	ET380834	Transistor 2SC711(E)	1
16-TR209	ET383466	Transistor CDC9000-1(B)	1
16-TR210, 1	ET371935	Transistor 2SC711(D)	2
16-TR212	ET380834	Transistor 2SC711(F)	1
16-TR213	ET383466	Transistor CDC9000-1(B)	1
16-TR214	ET380834	Transistor 2SC711(E)	1
16-D201	ED321243	Zener Diode 1N759A	1
16-D202 to 8	ED219464	Germanium Diode 1N34A	7
16-VR201	EV221837	Semi-fixed Volume V10K-5	1
100k B			
16-2	ZW201971	Screw, binding head 3x12	1
16-3x	EZ348647	Micro Switch Collar C	1
16-4x	EZ473477	COM P.C. Board Mt. Part	1
16-5x	ZW273756	M3 Nut	1
<b>Capacitor, Vertical Type</b>			
16-C201	EC220151	Elect. 100 $\mu$ F 25WV	1
16-C202	EC313108	Elect. 1 $\mu$ F 50WV	1
16-C203	EC220364	Elect. 100 $\mu$ F 6.3WV	1
16-C204	EC450281	Elect. 0.47 $\mu$ F 50WV	1

When ordering parts, please describe Parts Number, Serial Number, and Model Number in detail.

Symbol No.	Parts No.	Description	Qty
16-C205	EC350706	Elect. 4.7 $\mu$ F 16WV	1
16-C206	EC220127	Elect. 100 $\mu$ F 16WV	1
<b>Resistor, Stopper Type</b>			
16-R201	ER363644	Carbon RD1/4 560(J)	1
16-R202	ER346601	Carbon RD1/4 47k(J)	1
16-R203	ER212174	Carbon RD1/4 180k(J)	1
16-R204	ER346601	Carbon RD1/4 47k(J)	1
16-R205	ER306857	Carbon RD1/4 15k(J)	1
16-R206	ER363644	Carbon RD1/4 560(J)	1
16-R207	ER361642	Carbon RD1/4 47(J)	1
16-R208	ER346601	Carbon RD1/4 47k(J)	1
16-R209	ER357456	Carbon RD1/4 2.2k(J)	1
16-R210	ER336442	Carbon RD1/4 10k(J)	1
16-R211	ER357456	Carbon RD1/4 2.2k(J)	1
16-R212	ER212264	Carbon RD1/4 22k(J)	1
16-R213	ER336442	Carbon RD1/4 10k(J)	1
16-R214	ER361642	Carbon RD1/4 47(J)	1
16-R215	ER212264	Carbon RD1/4 22k(J)	1
16-R216	ER336442	Carbon RD1/4 10k(J)	1
16-R217, 8	ER213030	Carbon RD1/4 5.6k(J)	2
16-R219	ER212264	Carbon RD1/4 22k(J)	1
16-R220	ER361642	Carbon RD1/4 47(J)	1
16-R221	ER336442	Carbon RD1/4 10k(J)	1
16-R222	ER212883	Carbon RD1/4 4.7k(J)	1
16-R223, 4	ER371946	Carbon RD1/4 2k(J)	2
16-R225	ER212883	Carbon RD1/4 4.7k(J)	1
16-R226	ER336442	Carbon RD1/4 10k(J)	1
16-R227	ER212264	Carbon RD1/4 22k(J)	1
16-R228	ER380913	Carbon RD1/4 33(J)	1
16-R229, 30	ER213030	Carbon RD1/4 5.6k(J)	2
16-R231	ER212264	Carbon RD1/4 22k(J)	1
16-R232	ER336442	Carbon RD1/4 10k(J)	1
16-R233	ER213030	Carbon RD1/4 5.6k(J)	1
16-R234	ER212264	Carbon RD1/4 22k(J)	1
16-R235	ER361642	Carbon RD1/4 47(J)	1
16-R236	ER336442	Carbon RD1/4 10k(J)	1
16-R237	ER361642	Carbon RD1/4 47(J)	1
16-R238	ER213030	Carbon RD1/4 5.6k(J)	1
16-R239	ER212264	Carbon RD1/4 22k(J)	1
16-R240	ER336442	Carbon RD1/4 10k(J)	1
16-R241	ER212883	Carbon RD1/4 4.7k(J)	1
16-R242, 3	ER371946	Carbon RD1/4 2k(J)	2
16-R244	ER212883	Carbon RD1/4 4.7k(J)	1
16-R245	ER362441	Carbon RD1/4 1.8k(J)	1
16-R246	ER349942	Carbon RD1/4 8.2k(J)	1
16-R247	ER357456	Carbon RD1/4 2.2k(J)	1

FIG. 17 PHOTO OF TRACK SELECTOR P.C. BOARD (KH-5011)



TRACK SELECTOR P.C. BOARD (KH-5011) BLOCK

Symbol No.	Parts No.	Description	Qty
17-1x	BA482477	Track Selector P.C. Board Comp. (KH5011)	1
17-D1	ED224526	Silicon Diode 10D1	1
17-L1	EO495527	Ferri Inductor FL9H 330 $\mu$ H $\theta$	1
17-L2, 3	EO424888	Ferri Inductor FL5H 5.6MH $\theta$	2
17-L4	EO495527	Ferri Inductor FL9H 330 $\mu$ H $\theta$	1
17-RL1	EP383321	Relay TECK-36 DC22V 100 $\theta$	1
17-SW1	ES411805	Push Switch UM21620C	1
17-C1, 2	EC337487	Hi-Q Capacitor 470PF(J) 50WV	2

FIG. 18 PHOTO OF MONITOR SWITCH  
P.C. BOARD (KH-5012)

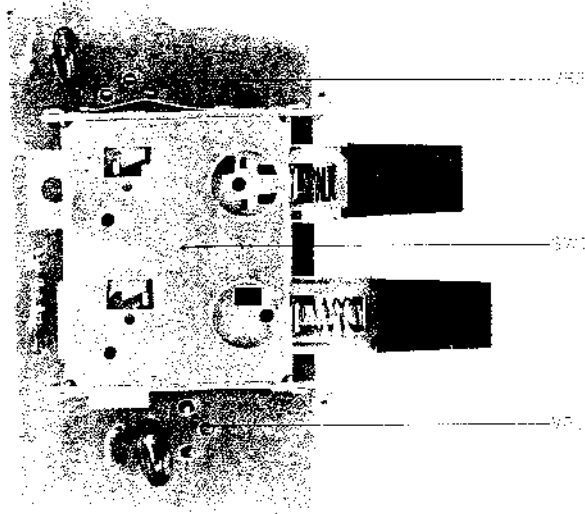
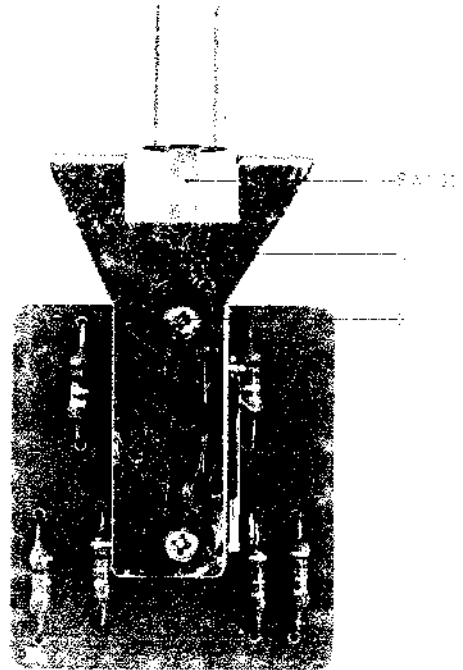


FIG. 19 PHOTO OF COM SWITCH  
P.C. BOARD (RD-525)



**MONITOR SWITCH  
P.C. BOARD (KH-5012) BLOCK**

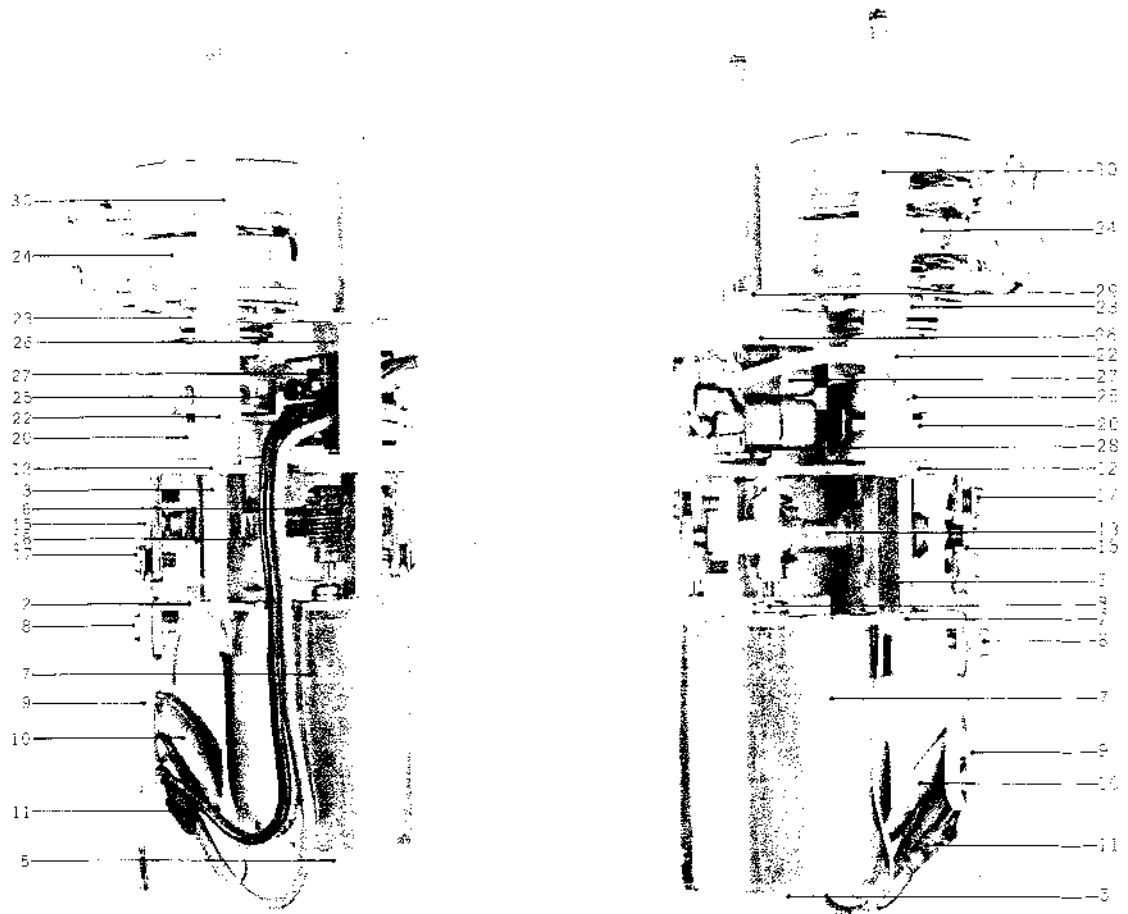
Symbol No.	Parts No.	Description	Q'ty
18-1x	BA482488	Monitor Switch P.C. Board Comp. (KH-5012)	1
18-VR1, 2	EV482962	Semi-fixed Volume V-10K5-2-4 5k B. w/knob	2
18-SW1	ES245103	Push Switch UM21220J	1
18-C1, 2	EC389496	Mylar 0.068 $\mu$ F(J) 50WV (Vert. type)	2
		<b>Resistor, Stopper Type</b>	
18-R1	ER212264	Carbon RD1/4 22k(J)	1
18-R2	ER364994	Carbon RD1/4 39k(J) (Insu. type)	1
18-R3	ER212264	Carbon RD1/4 22k(J)	1

**COM SWITCH P.C. BOARD (RD-525) BLOCK**

Symbol No.	Parts No.	Description	Q'ty
19-1x	BA482455	COM Switch P.C. Board Comp. (RD-525)	1
19-SW1	ES482872	Push Switch UEG62BP, without knob	1
19-2	EZ472490	COM Switch Mt. Part	1
19-3	ZW202331	Screw, round head 2.6x4	2
		<b>Resistor, Insulator Type</b>	
19-R101 to 104	ER329308	Carbon RD1/4 47k(J)	4
19-R105, 6	ER213715	Carbon RD1/4 100k(J)	2



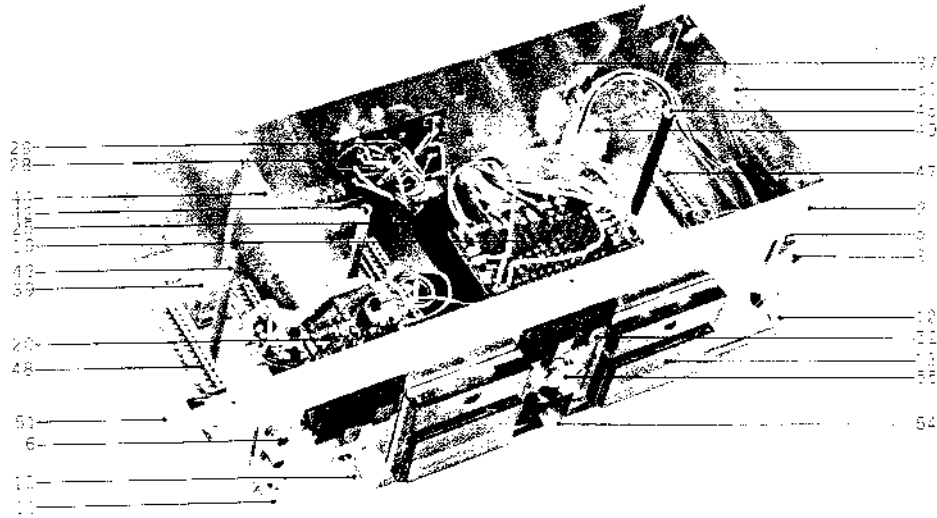
FIG. 20 PHOTO OF COM MECHANISM BLOCK



COM MECHANISM BLOCK

Ref. No.	Parts No.	Description	Schematic No.	Q'ty	Ref. No.	Parts No.	Description	Schematic No.	Q'ty
20-1x	BM482466	COM Mechanism Block Comp.	RD-590	1	20-16x	ZW269785	M2.3 Toothed Lock Washer		6
20-2	EZ262181	COM Motor Frame	RD-591	1	20-17	ZW201914	Screw, binding head 2.3x5		4
20-3	EZ262091	COM Prop C	RD-590	3	20-18	MS252887	Main Gear Shaft, w/gear	RD-585	1
20-4x	ZW200362	Screw, countersunk head 3x5 D=5		3	20-19x	ZW383332	Washer (PBP)103.1x5x0.14		1
20-5	BM250514	Micro Motor FM-36K 108700	53-1-1	1	20-20	EZ383130	Clutch A, w/pin	RD-A509	1
20-6	EZ262023	COM Worm-Gear B	RD-592	1	20-21x	ZW313470	Set Screw 3x6.5(cup)		2
20-7	EZ262067	COM Shield	RD-593	1	20-22	EZ262080	COM Prop B	RD-578	3
20-8	ZW201914	Screw, binding head 2.3x5		4	20-23	EZ262102	COM Switch Base	RD-597	1
20-9	EA383128	Terminal P.C. Board	RD-A512	1	20-24	EV326160	Dual-axial 2-throw/Vol. V24L5G(SP) N12.5R-100kx	3-6-1-5	1
20-10	EC228745	Ceramic/C. YZ 0.1 μF(Z) 50WV	24-5-33	3	20-25	EZ383141	Clutch B	RD-A510	1
20-11	ER230185	Solid/R. RC1/4W 33(K)	35-5-1	2	20-26	ZW383152	Switch Insulator Washer	RD-A511	1
20-12	EZ218147	Gear Frame	RD-582	1	20-27	ES250020	Micro Switch S-1 AL	2-5-1-9	2
20-13	MS222693	Sub Gear Shaft, w/gear	RD-584	1	20-28	ZW383343	Screw, binding head 2.3x22		2
20-14x	ZW259334	Washer (Polystyler) D2.05x3.5x0.251		2	20-29	ZW273690	M2.3 Nut		2
20-15	EZ228857	Center Plate	RD-583	2	20-30	MH473488	COM Mt. Prop	RD-595	3
					20-31x	EZ262056	COM Rubber Shield	RD-596	1

FIG. 21 PHOTO OF AMP. ASSEMBLY BLOCK



## AMP. ASSEMBLY BLOCK

Ref. No.	Parts No.	Description	Schematic No.	Q'ty
<b>AMP. FRAME BLOCK</b>				
21-1x	BZ482444	Amp. Frame Block Comp.	KH	1
21-2	EZ472577	Amp. Chassis A	KH-5001	1
21-3	EJ442078	Mic. Jack 3PMJ4	31-2-36	1
21-4x	ZW482927	Washer (SPC)D9.2x14x0.5t		1
21-5	ZW375153	E Jack Nut		3
21-6	EJ433844	Mic. Jack 2PMJ4	31-2-35	2
21-7x	EZ225180	Nylon Collar, Jack	LD-526	2
21-8x	ZW492884	Washer (Fiber)D9.2x14x0.5t		2
21-9x	ER213647	Carbon/R. RD1/4 10k(J) (Insu. type)	35-9-5	2
21-10	EV472588	Dual-axial Double/Vol. D24N 50k Ax2 (Line)	36-3-38	1
21-11	EV472590	Dual-axial Double/Vol. D24N 100k Ax2 (Mic)	36-3-39	1
21-12	EV403661	Double/Vol. (Frictional) DJ20A 10k Ax2 (Line out)	36-3-37	1
21-13	EM472612	VU Meter KL-250B-13	46-1-56	2
21-14	EA472601	Meter P.C. Board	KH-5007	2
21-15	EL295312	No. 2 Lamp 8V 0.2A	26-2-8	4
21-16x	ZG317968	Angle Spring	NR-14	6
21-17x	ZW424495	Washer (SPC)D3.1x8x1t		2
21-18x	ZW348107	M3 Iso Nut		6
21-19	BA482477	Track Selector P.C. Board Comp. (KH-5011)		1
21-20	BA482488	Monitor Switch P.C. Board Comp. (KH-5012)		1
21-21x	ZW371856	Iso Screw, binding head 3x5		2
21-22	BA482455	COM Switch P.C. Board Comp. (RD-525)		1
21-23x	ZW323728	Screw, binding head 3x5		2
21-24x	SZ510197	COM Insulator Plate	KH-5029	1
21-25	BM482466	COM Mechanism Block Comp. KH-RDG		1
21-26x	ZW273756	M3 Nut		3
<b>JACK PLATE BLOCK</b>				
21-27x	BZ482534	Jack Plate Block Comp.	KH	1
21-28	EJ452046	RDG Line Jack Plate	31-3-43	1
21-29	EJ378990	5P Din-Jack S-1 8123	31-1-1	1
21-30	ES379045	6P Slide Switch SJ-0282	25-3-36	1
21-31x	ZW410231	Screw, pan head 2.6x5		2
21-32x	ZW273778	M3 Earth Lug		1
21-33x	ER324685	Carbon/R. RD1/4 33k(J) (Insu. type)	35-9-5	2
21-34x	ER213873	Carbon/R. RD1/4 150k(J) (Insu. type)	35-9-5	2
21-35x	ER345712	Carbon/R. RD1/4 22k(J) (Insu. type)	35-9-5	2
21-36x	ER213647	Carbon/R. RD1/4 10k(J) (Insu. type)	35-9-5	2
<b>AMP. ASSEMBLY BLOCK</b>				
21-37	UM472522	Amp. Chassis B	KH-5002	1
21-38	EA472533	Rec. Relay P.C. Board	KH-5009	1
21-39	EP383321	Relay TECK-36 DC22V 1000	47-2-20	1
21-40	ZW447772	Tapping Screw 3x6(BR)		23
21-41x	ZW273778	M3 Earth Lug		4
21-42	MH472544	P.C. Board Retaining Prop	KH-5005	2
21-43x	ZW417150	Screw, pan head 4x6		2
21-44	EZ472555	Rec. Amp. Shield	KH-5017	1
21-45	MH472566	OSC. Retaining Prop	KH-5002	1
21-46x	ZW413155	Screw, binding head 3x6		1
21-47	EJ482793	10P Multi-Jack 3250-010-001	31-4-21	2
21-48	EJ368785	14P Multi-Jack 3250-014-001	31-4-14	6
21-49	EJ300508	9P Mate-N-Lock Plug Housing 1-480274-0	52-1-7	1
21-50x	EJ373634	Socket Contact 61115-1	52-1-1	7
21-51	EZ473771	Side Frame	KH-5003	2
21-52	SK474107	Push Knob	KH-5026	4
21-53x	EZ473782	Card Retainer A	KH-5018	1
21-54	SK436252	Knob B	KH-2015	1
21-55	SK493018	COM Knob	KH-5028	1

FIG. 22 PHOTO OF FINAL ASSEMBLY BLOCK



**FINAL ASSEMBLY BLOCK**

Ref. No.	Parts No.	Description	Schematic No.	Q'ty	Ref. No.	Parts No.	Description	Schematic No.	Q'ty
<b>MECH. PANEL BLOCK</b>					<b>FINAL ASSEMBLY BLOCK</b>				
22-1x	BZ482264	Mech. Panel Block Comp.	KH	1	22-34x	SZ382230	Ventilator (upper)	RD-A 404	1
22-2	SP473556	Mech. Panel	KH-6001	1	22-35x	ZW439661	Screw, truss head 3x14 (without groove)		4
22-3	SE486088	Counter Escutcheon B	KH-6008	1	22-36x	ZW273756	M3 Nut		4
22-4	SZ473567	Reel Protector	KH-6003	2	22-37x	SZ382241	Ventilator Retaining Plate	RD-A 405	1
22-5x	ZW417137	Screw, binding head 3x4		12	22-38x	ZW200610	Tapping Screw #1 4x12(truss)		1
22-6	SC473578	Head Cover Base	KH-6004	1	22-39	SZ377190	LM Rubber Foot	EM-404	4
22-7	SM473591	Pause Name Plate	KH-6009	1	22-40x	ZW419646	Washer (SPC)D4.5x9.8x0.5t		4
22-8	SZ409320	Illumination Escutcheon (orange)	61-5023	1	22-41x	ZW403571	Wood Screw, round head 4.5x20		4
22-9x	SZ473580	Head Cover Rotation Base	KH-6005	1					
22-10x	ZW413741	Screw, binding head 3x8		2					
22-11x	SZ492030	Ball Case	KH-6034	1					
22-12x	MV269965	Steel Ball D4		1					
22-13x	ZG249107	Ball Retaining Spring	RD-632	1					
22-14x	ZW383883	Set Screw 5x4(flat)		1					
22-15	EZ426780	Illumination Escutcheon (red)	61-5025	1					
22-16	SC473602	Head Cover	KH-6008	1					
22-17	SM473613	Head Cover Plate	KH-6024	1					
22-18x	MS473624	Head Cover Shaft	KH-5907	1					
22-19x	SZ473635	Rolling Sleeve	KH-6006	1					
22-20x	ZW434160	Set Screw, hexagon socket 3x3(cup)		2					
22-21x	ZW482657	Set Screw, hexagon socket 4x3(cup)		1					
22-22x	SZ487877	Stopper Rubber	KH-6033	2					
22-23x	SZ473646	Stopper Rubber	KH-1020	2					
<b>AMP. PANEL BLOCK</b>									
22-24x	BZ482253	Amp. Panel Block Comp.	KH	1					
22-25	SP473804	Amp. Panel	KH-6018	1					
22-26	SC473815	VU Meter Cover	KH-6020	2					
22-27x	ZW487866	Screw, round head 2.6x6		6					
22-28	EZ397890	Rec. Button Escutcheon	KD-5003	1					
22-29	SZ492941	COM Guide	KH-6036	1					
22-30	SZ436151	Lamp Escutcheon (red)	DF-6025	1					
<b>CASE BLOCK</b>									
22-31	BC482242	Case Block Comp.	KH	1					
22-32x	SZ439694	Case Corner Angle	KD-6021	2					
22-33x	ZW447963	Tapping Screw #1 3x10(truss)		8					
					22-42	SP473703	Sash A (right)	KH-5023A	1
					22-43	SP473714	Sash B (left)	KH-5023B	1
					22-44x	ZW200384	Screw, countersunk head 3x6		2
					22-45	ZW408418	Panel Washer	KH-5029	2
					22-46	ZW203084	Screw, oval countersunk head 3x8		2
					22-47x	ZW201150	Screw, truss head 3x6 (black)		2
					22-48	SZ483737	Panel Washer B (black)	KH-5029	2
					22-49	ZW482815	Screw, oval countersunk head 3x8		2
					22-50x	ZW259806	Washer (SPC)D4.5x12.8x1t		6
					22-51x	ZW487833	Tapping Screw #1 4x50(truss)		4
					22-52x	SZ377190	LM Rubber Foot	EM-404	4
					22-53x	ZW419646	Washer (SPC)D4.5x9.8x0.5t		4
					22-54x	ZW434283	Tapping Screw #1 4x30(truss)		4
					22-55x	ZW200621	Tapping Screw #1 4x25(truss)		2
					22-56	SK425158	Pinch Roller Cap	MS-5020	1
					22-57	MP424023	Pinch Roller (KD)	KH-5024	1
					22-58	SK474063	Volume Knob B	KH-5011	3
					22-59x	ZW487844	Set Screw, hexagon socket 3x7(cup)		3
					22-60	SK474074	Volume Knob A	KH-5012	3
					22-61x	ZW433001	Set Screw, hexagon socket 3x5(cup)		3
					22-62x	FZ436217	Collar, Jack	ML-5008	3
					22-63x	SZ473501	Ventilator Panel (back)	KH-5025	1
					22-64x	ZW324448	Tapping Screw #1 3x10(truss)		4
					22-65x	EF444183	Fuse 1.5A 250V	39-1-3	1
					22-66x	EF277413	Fuse ST-2 2A	39-1-25	1
					22-67x	EF338387	Fuse ST-2 1.5A	39-1-25	1

When ordering parts, please describe Parts Number, Serial Number, and Model Number in detail.

# INDEX

Parts No.	Ref. No. & Symbol No.	Parts No.	Ref. No. & Symbol No.	Parts No.	Ref. No. & Symbol No.	Parts No.	Ref. No. & Symbol No.	Parts No.	Ref. No. & Symbol No.
BA482332	11-1x	EC220994	13-C20	EC432810	14-C12	EO243977	9-L1	ER212883	12-R10 to 12
BA482365	12-1x	EC220994	13-C24	EC434081	7-3	EO243977	9-L4	ER212883	12-R12
BA482387	6-19x	EC220994	14-C9	EC438524	11-C211	EO262484	14-L1	ER212883	12-R15
BA482387	9-1x	EC220994	14-C17	EC442080	15-C4	EO383365	15-T1	ER212883	12-R17,8
BA482398	6-3x	EC228745	20-10	EC450055	12-C12,3,4	EO403446	10-L1	ER212883	12-R21
BA482398	6-2.5x	EC250604	13-C10	EC450055	14-C18	EO424888	17-L2,3	ER212883	12-R23,4
BA482455	19-1x	EC250661	11-C206	EC450055	14-C20	EO458932	9-L2,3	ER212883	12-R18
BA482455	21-22	EC250841	14-C8	EC450281	16-C204	EO495527	17-L1	ER212883	12-R27
BA482477	17-1x	EC250841	15-C2, 3	EC450281	11-C257	EO495527	17-L4	ER212883	12-R24,5
BA482477	21-19	EC250885	12-C20	EC450527	12-C1,2	EP344136	1-62	ER212883	12-R29 to 31
BA482488	18-1x	EC250975	9-C5	EC456041	12-C3 to 5	EP344136	12-RL1 to 6	ER212883	12-R34
BA482488	21-20	EC250975	9-C10	EC487394	13-C5	EP344136	12-RL1 to 6	ER212883	12-R35,6
BA482490	13-1x	EC251087	12-C14	EC487394	13-C17	EP344136	15-RL2	ER212883	12-R39,40
BA482501	14-1x	EC251190	11-C202	ED219464	12-D5 to 9	EP383321	15-RL1	ER212883	12-R40
BA482512	15-1x	EC251190	12-C13	ED219464	12-D11 to 14	EP383321	17-RL1	ER212883	12-R44
BA482523	16-1x	EC273464	7-25	ED219464	12-D18 to 21	EP383321	21-39	ER212883	12-R46
BA482578	7-14	EC273464	8-58	ED219464	12-D23	EP398610	8-2	ER212883	12-R50,1
BA495808	10-1x	EC273464	12-C6	ED219464	12-D26,7	EP441990	8-10	ER212883	12-R54
BA515520	12-2x	EC273464	12-C16	ED219464	14-D1,2	EP804813	1-54	ER212883	14-R7
BC473927	4-5	EC290564	14-C13	ED219464	16-D202 to 8	ER211465	6-30	ER212883	14-R12
BC482242	22-31	EC290564	14-C15	ED224526	1-71	ER211465	11-R224,5	ER212883	15-R5
BH482310	1-1x	EC290586	13-C3	ED224526	6-33	ER211465	12-R1	ER212883	16-R222
BL482422	4-1x	EC290586	14-C3	ED224526	11-D201,2	ER211465	12-R4	ER212883	16-R225
BM250514	20-5	EC302253	13-C19	ED224526	11-D204	ER211465	12-R8	ER212883	16-R241
BM314741	3-1	EC308711	12-C7	ED224526	12-D1 to 4	ER211465	12-R13	ER212883	16-R244
BM482286	2-1x	EC313108	16-C202	ED224526	12-D5	ER211465	12-R16	ER213030	11-R221
BM482466	20-1x	EC316091	7-17	ED224526	12-D10	ER211465	12-R19	ER213030	12-R37,8
BM482466	21-25	EC320040	13-C18	ED224526	12-D13	ER211465	12-R22	ER213030	12-R42
BP482343	7-1x	EC320051	11-C205	ED224526	12-D15 to 17	ER211465	12-R25	ER213030	13-R17,8
BR482400	3-2x	EC320051	13-C14	ED224526	12-D20	ER211465	12-R28	ER213030	16-R217,8
BR482411	3-3x	EC320051	13-C23	ED224526	12-D22	ER211465	12-R32	ER213030	16-R229,30
BS482308	5-1x	EC320051	14-C19	ED224526	12-D28	ER211465	12-R35	ER213030	16-R233
BS482354	8-24x	EC329771	13-C6	ED224526	12-D33,34	ER211465	12-R41	ER213030	16-R238
BT47768	14-T1	EC329771	14-C4	ED224526	15-D1,2	ER211465	12-R41	ER213300	11-R31
BT472702	7-10	EC329771	14-C6	ED224526	17-D1	ER211465	12-R43	ER213300	11-R33
BZ398338	8-1x	EC329771	14-C14	ED224550	7-15	ER211465	12-R43	ER213300	11-R33
BZ472656	6-2	EC329848	9-C13	ED224550	7-29x	ER211465	12-R46,7	ER213467	13-R20
BZ482253	22-24x	EC329848	9-C15	ED224550	12-D6,7	ER211465	13-R15	ER213647	21-9x
BZ482264	22-1x	EC329850	11-C209	ED224550	12-D6,7	ER211465	13-R33	ER213647	21-36x
BZ482297	8-9x	EC331705	11-C203	ED321243	16-D201	ER211667	11-R220	ER213715	19-R105,6
BZ482376	6-1x	EC331817	11-C254	ED321390	11-TH201	ER211667	12-R34	ER213873	21-34x
BZ482444	21-1x	EC336126	12-C12	ED329128	11-D252	ER211667	15-R9	ER230185	24-11
BZ482534	21-27x	EC337487	17-C1,2	ED329130	7-16	ER211757	11-R209	ER251684	11-R2
EA222096	1-67x	EC341842	7-26	ED329130	11-D251	ER211757	12-R1	ER304290	11-R226
EA383128	20-9	EC346746	7-19	ED329130	11-D253	ER211757	13-R21	ER304290	11-R36
EA396898	6-11	EC348704	8-120	ED348096	11-D253	ER211858	13-R14	ER304402	11-R229
EA463206	1-30x	EC350684	11-C208	ED514721	12-D1 to 4	ER211858	13-R31	ER304402	11-R13
EA472533	21-38	EC350684	11-C255	ED514721	12-D8 to 12	ER212174	16-R203	ER304402	11-R6
EA472601	21-14	EC350684	12-C5	ED514721	12-D14 to 19	ER212264	11-R204	ER306843	11-R255
EA472724	6-26	EC350684	13-C7	ED514721	12-D21 to 27	ER212264	12-R17	ER306843	11-R32
EA473016	8-96	EC350684	15-C1	ED514721	12-D29 to 32	ER212264	12-R19	ER306887	11-R217
EA473376	1-64	EC350706	16-C205	ED514721	12-D35 to 42	ER212264	12-R44	ER306887	11-R227
EA487991	5-17	EC350875	9-C12	EF277413	7-37x	ER212264	12-R47,8,9	ER306887	14-R205
EC220127	16-C206	EC350875	9-C14	EF277413	22-66x	ER212264	12-R52,3	ER315944	11-R3,4
EC220151	1-70	EC350875	9-C14	EF338387	22-67x	ER212264	12-R56,7	ER320207	11-R2,3
EC220151	11-C207	EC365692	7-18	EF444183	22-65x	ER212264	13-R28	ER324685	21-3x
EC220151	11-C216	EC368280	11-C215	EI412413	14-C1	ER212264	14-R15	ER329308	14-R101 to 104
EC220151	12-C19	EC368335	9-C4	EJ205975	8-127	ER212264	14-R18	ER336442	11-R201
EC220151	13-C13	EC368335	9-C11	EJ222748	8-113	ER212264	16-R215	ER336442	11-R205,6,7
EC220151	14-C10,1	EC372148	11-C253	EJ233370	7-36	ER212264	16-R219	ER336442	11-R3
EC220151	15-C9	EC372148	14-C5	EJ254970	8-83x	ER212264	16-R227	ER336442	11-R14
EC220151	16-C201	EC379157	9-C1	EJ255115	7-27	ER212264	16-R231	ER336442	11-R20
EC220364	6-31	EC379157	9-C3	EJ300508	21-49	ER212264	16-R234	ER336442	11-R26
EC220364	14-C16	EC379157	9-C7	EJ310871	8-109x	ER212264	16-R239	ER336442	11-R33
EC220364	16-C203	EC379192	9-C9	EJ326430	8-132	ER212264	16-R239	ER336442	11-R33
EC220432	12-C7 to 10	EC379787	11-C204	EJ347670	8-110x	ER212264	18-R1	ER336442	11-R37
EC220432	12-C17	EC389485	9-C2	EJ368785	8-115	ER212264	18-R3	ER336442	11-R43
EC220465	13-C4	EC389485	9-C8	EJ368785	8-115	ER212477	13-R9,10	ER336442	11-R48
EC220465	13-C12	EC389496	18-C1,2	EJ368785	21-48	ER212477	13-R35	ER336442	11-R1
EC220465	13-C16	EC398632	7-4	EJ373634	21-50x	ER212477	14-R8	ER336442	11-R11
EC220612	12-C1 to 4	EC398957	11-C201	EJ378944	8-122	ER212681	11-R211	ER336442	11-R3
EC220612	13-C1	EC403468	11-C251,2	EJ378990	21-29	ER212681	11-R252	ER336442	11-R9
EC220678	13-C8	EC411827	9-C6	EI433844	21-6	ER212681	13-R5	ER336442	14-R14
EC220678	14-C2	EC411827	9-C16	EJ442078	21-3	ER212681	13-R30	ER336442	16-R210
EC220994	11-C213	EC423562	13-C25	EJ450573	8-111	ER212681	14-R4	ER336442	16-R213
EC220994	12-C6	EC424080	11-C210	EJ452046	21-28	ER212883	6-29	ER336442	16-R216
EC220994	12-C8	EC425250	15-C5 to 8	EJ482793	21-47	ER212883	11-R214	ER336442	16-R221
EC220994	12-C10, 11	EC429851	14-C7	EL236125	5-18	ER212883	11-R218	ER336442	16-R226
EC220994	12-C11	EC432810	13-C2	EL295312	21-15	ER212883	12-R4,5	ER336442	16-R232
EC220994	13-C11	EC432810	13-C9	EL390576	6-12x	ER212883	12-R5,6,7	ER336442	16-R236
EC220994	13-C11	EC432810	14-C1	EL390576	6-32	ER212883	12-R7	ER336442	16-R240
				EM472612	21-13	ER212883	12-R9	ER339805	78

# INDEX

Parts No.	Ref. No. & Symbol No.	Parts No.	Ref. No. & Symbol No.	Parts No.	Ref. No. & Symbol No.	Parts No.	Ref. No. & Symbol No.	Parts No.	Ref. No. & Symbol No.
ER342933	13-R6	ER399723	12-R38	ET515880	12-TR13	HZ473231	1-45	MZ397080	8-48
ER342933	13-R26	ER403097	11-R213	EV221826	12-VR2	HZ473297	1-52	MZ397170	7-39
ER342933	14-R6	ER403187	11-R212	EV221826	13-VR1	HZ473308	1-53	MZ397181	8-69
ER343078	11-R253	ER424078	11-R228	EV221837	16-VR201	HZ473332	1-3	MZ397214	8-104
ER343078	12-R11	ER426690	7-6	EV221850	14-VR1	HZ473343	1-10	MZ397337	6-43
ER343078	12-R14	ER426892	15-R1	EV326160	20-24	HZ473354	1-56	MZ398182	2-16
ER343078	12-R27	ER427083	14-R1,2	EV398812	14-VR2	HZ473365	1-55	MZ400421	2-18
ER343078	12-R45	ER429996	12-R8	EV403661	21-12	HZ482714	1-5	MZ402377	8-26
ER345712	21-35x	ER429996	14-R16	EV426936	12-VR1	HZ488092	1-72x	MZ405437	2-2
ER345756	5-19	ER430053	6-28	EV472588	21-10	HZ809976	1-39	MZ428343	1-86
ER346601	12-R9	ER430143	7-24x	EV472590	21-11	MB303535	3-32	MZ434237	8-65
ER346601	12-R45	ER447682	11-R256	EV482962	18-VR1,2	MB303535	8-105x	MZ465772	7-12
ER346601	12-R55	ER450011	13-R19	EV484863	11-VR251	MB314987	3-25	MZ467111	8-82x
ER346601	13-R13	ER455848	15-R7	EV498060	11-VR202	MB314987	8-76	MZ472667	6-6
ER346601	16-R202	ER466986	7-28	EV513562	12-VR1,2	MC399521	8-50	MZ472680	6-10
ER346601	16-R204	ER472296	7-9x	EZ218147	20-12	MH472544	21-42	MZ472691	6-15
ER346601	16-R208	ER493097	7-7	EZ225180	21-7x	MH472566	21-45	MZ472781	6-38
ER346994	13-R7,8	ER493110	12-R58	EZ228857	20-15	MH473027	8-97	MZ472792	6-23
ER347038	11-R257	ES245103	18-SW1	EZ246936	8-124x	MH473207	1-36	MZ472814	8-32
ER347038	15-R8	ES250020	20-27	EZ262023	20-6	MH473488	20-30	MZ472836	6-44
ER349784	13-R34	ES250064	8-27	EZ262056	20-31x	MH487888	8-44	MZ472858	8-121
ER349907	14-R11	ES250064	8-55	EZ262067	20-7	MH487890	8-116x	MZ472904	8-62
ER349942	13-R4	ES250064	8-60	EZ262080	20-22	ML314976	3-23	MZ473005	8-85
ER349942	16-R246	ES250075	6-42	EZ262091	20-3	ML314976	8-75	MZ473038	9-98
ER352045	13-R16	ES375478	7-33	EZ262102	20-23	ML396742	8-72	MZ473040	8-100
ER352045	13-R23	ES379045	21-30	EZ262181	20-2	ML396810	3-24x	MZ473051	8-140
ER352045	13-R32	ES411805	17-SW1	EZ315448	8-126x	ML396810	8-81	MZ473073	8-138
ER357412	12-R39	ES468426	5-14	EZ328320	1-68x	ML397383	8-30	MZ473455	8-25
ER357456	11-R203	ES472645	9-SW1	EZ328320	7-30x	ML409083	8-134	MZ473938	4-8
ER357456	11-R210	ES482861	6-16	EZ348647	16-3x	ML472950	8-84	MZ473995	5-6
ER357456	11-R219	ES482872	19-SW1	EZ374894	8-125	ML492906	8-137	MZ474006	5-2
ER357456	11-R222,3	ES482938	5-11	EZ382263	8-123	MP424023	8-149x	MZ474513	6-41
ER357456	11-R251	ES482938	8-106	EZ383130	20-20	MP424023	22-57	MZ486448	8-103
ER357456	11-R254	ET234832	13-TR7	EZ383141	20-25	MR317507	3-17	MZ486450	8-66
ER357456	12-R10	ET234843	13-TR1,2	EZ397124	8-128	MS222693	20-13	MZ499634	8-64
ER357456	12-R13	ET234843	13-TR4	EZ397135	8-118	MS250165	6-45	MZ512133	8-53
ER357456	12-R26	ET304255	15-TR1,2	EZ397282	7-21	MS252887	20-18	MZ514653	8-154
ER357456	12-R30	ET329242	13-TR3	EZ397304	7-32	MS342000	3-6	MZ802980	8-22
ER357456	14-R17,8	ET329242	13-TR5	EZ397743	8-119x	MS397001	8-33	SB472768	6-36
ER357456	16-R209	ET338894	12-TR11 to 13	EZ397890	22-28	MS397012	8-36	SB474041	8-107
ER357456	16-R211	ET338894	13-TR6	EZ397956	6-5	MS397023	8-40	SB474052	6-21x
ER357456	16-R247	ET356984	11-TR202	EZ398946	7-23	MS408497	8-133	SB474118	5-13
ER357535	12-R15,6	ET356984	11-TR205	EZ407586	11-2	MS438243	6-37	SB867205	6-34
ER357535	12-R22,3	ET371935	16-TR202,3,4	EZ425226	15-2	MS438254	8-28	SB867565	6-35
ER357570	14-R5	ET371935	16-TR210,1	EZ426780	22-15	MS465480	8-38	SC473578	22-6
ER361528	13-R27	ET379462	11-TR201	EZ436217	22-62x	MS473624	22-18x	SC473602	22-16
ER361563	1-69	ET379462	11-TR203,4	EZ472490	19-2	MS473657	2-8	SC473815	22-26
ER361642	11-R208	ET379462	11-TR207	EZ472555	21-44	MS473916	4-2	SE486088	22-3
ER361642	15-R10	ET380834	16-TR201	EZ472577	21-2	MS473962	5-3	SK425158	22-56
ER361642	16-R207	ET380834	16-TR205,6	EZ473400	11-10x	MT255420	3-5	SK436252	21-54
ER361642	16-R214	ET380834	16-TR208	EZ473477	16-4x	MT297663	3-8	SK472678	6-9
ER361642	16-R220	ET380834	16-TR212	EZ473771	21-51	MT436860	3-14	SK474063	22-58
ER361642	16-R235	ET380834	16-TR214	EZ473782	21-53x	MT473422	3-10	SK474074	22-6
ER361642	16-R237	ET383466	16-TR207	EZ474017	11-6	MT473433	3-12	SK474107	21-52
ER362441	9-R1	ET383466	16-TR209	EZ495843	10-2x	MT473444	3-11x	SK482646	5-16
ER362441	9-R6	ET383466	16-TR213	HK398452	2-17	MT488147	3-4	SK482850	6-18
ER362441	11-R202	ET391138	11-TR253	HL473242	1-47	MV248130	2-9	SK493018	21-55
ER362441	13-R24	ET398711	6-27	HL473253	1-49	MV248141	4-7	SM473591	22-7
ER362441	16-R245	ET398711	12-TR1 to 10	HL473264	1-50	MV269965	22-12x	SM473613	22-17
ER362485	12-R2	ET398711	12-TR14 to 17	HL473387	1-77	MV408510	2-4	SP473703	22-42
ER362485	12-R6	ET398711	14-TR3	HL809998	1-74	MZ250413	8-54	SP473714	22-43
ER362485	12-R20,1	ET398777	11-TR206	HP384524	1-29	MZ292678	4-12	SP473556	22-2
ER363644	13-R25	ET399868	14-TR1,2	HR482321	1-7	MZ302400	8-114x	SP473804	22-25
ER363644	16-R201	ET399936	11-TR208	HZ243191	8-112x	MZ314998	3-26	SZ377190	22-39
ER363644	16-R206	ET403042	11-TR209	HZ317632	8-141	MZ314998	8-77	SZ377190	22-52x
ER364994	18-R2	ET403042	11-TR252	HZ321344	1-57	MZ315000	3-27	SZ382230	22-34x
ER371946	16-R242,3	ET408971	11-TR251	HZ321366	1-61	MZ315000	8-78	SZ382241	22-37x
ER371946	16-R223,4	ET515700	12-TR2	HZ321434	1-82	MZ317373	3-21	SZ397517	8-15 0
ER376424	8-3x	ET515700	12-TR9	HZ382667	1-32	MZ317373	8-43	SZ397528	8-15 1
ER376424	8-11x	ET515700	12-TR12	HZ397034	8-41	MZ317406	3-31	SZ409320	22-8
ER376424	12-CR1 to 3	ET515700	12-TR15	HZ434272	1-84	MZ317406	8-147	SZ436151	22-30
ER376424	12-CR1 to 3	ET515722	12-TR1	HZ473084	1-2	MZ396832	8-68	SZ439694	22-32x
ER380711	14-R10	ET515722	12-TR3	HZ473128	1-35	MZ396911	8-4	SZ473501	22-63x
ER380755	13-R29	ET515722	12-TR5	HZ473130	1-31	MZ396911	8-12	SZ473567	22-4
ER380913	16-R228	ET515722	12-TR7,8	HZ473141	1-16	MZ396933	8-20	SZ473580	22-9x
ER383758	13-R2,3	ET515722	12-TR10,1	HZ473152	1-8	MZ396944	8-16	SZ473635	22-19x
ER383758	13-R12	ET515722	12-TR14	HZ473163	1-17	MZ396966	8-14	SZ473646	22-23x
ER391623	12-R28,9	ET515722	12-TR16	HZ473174	1-22	MZ396977	8-6	SZ473681	8-15 5
ER399060	9-R2	ET515733	12-TR4	HZ473185	1-18	MZ397045	8-46x	SZ473692	8-15 6
ER399060	9-R4	ET515733	12-TR6	HZ473220	1-63	MZ397078	8-51	SZ473725	8-15 2

# INDEX

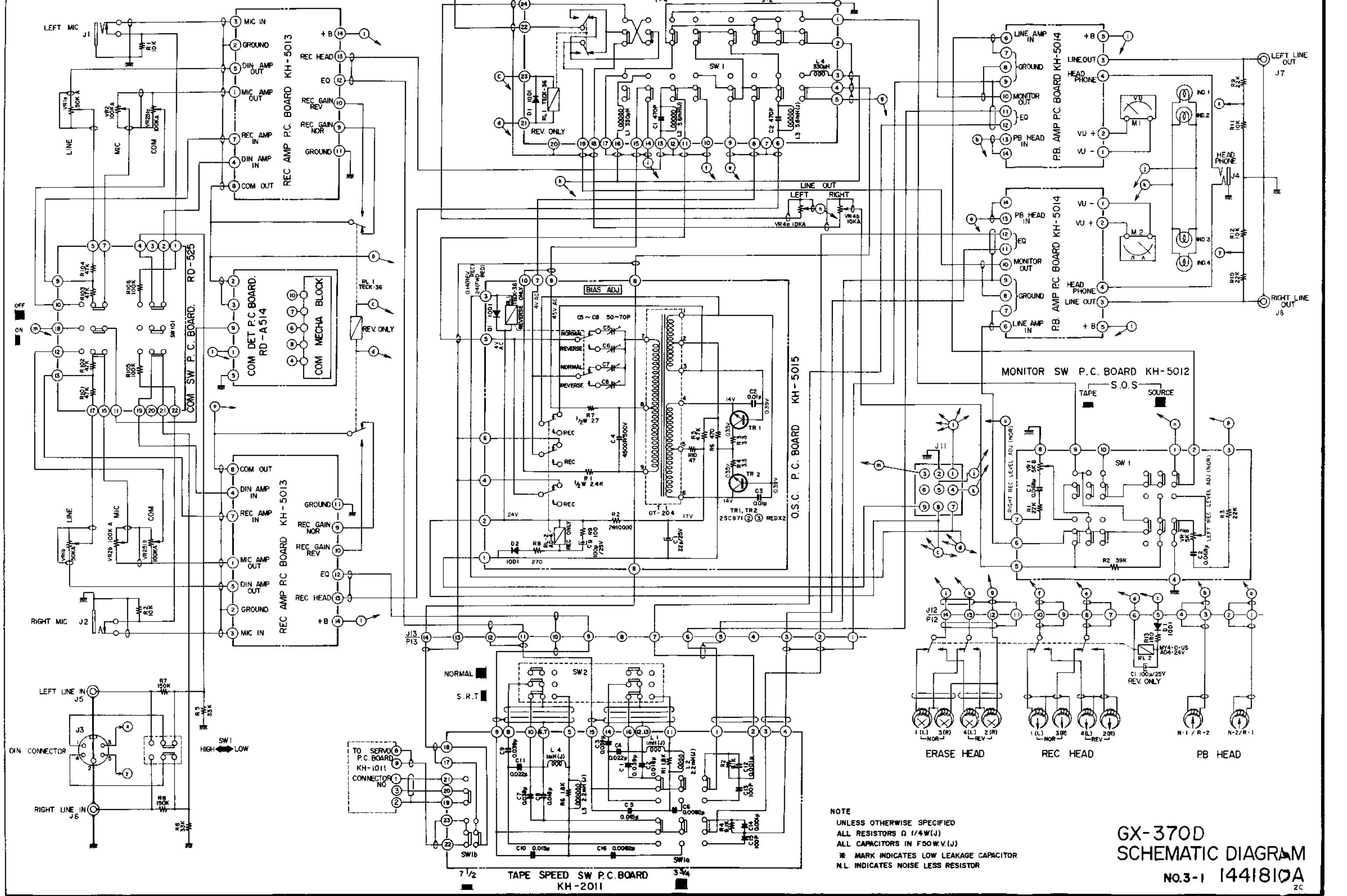
Parts No.	Ref. No. & Symbol No.	Parts No.	Ref. No. & Symbol No.	Parts No.	Ref. No. & Symbol No.	Parts No.	Ref. No. & Symbol No.	Parts No.	Ref. No. & Symbol No.
SZ483737	22-48	ZW273756	21-26x	ZW413201	4-14	ZW492063	8-139		
SZ487877	22-22x	ZW273756	22-36x	ZW413223	1-41	ZW492884	21-8x		
SZ492030	22-11x	ZW273778	1-24	ZW413223	1-76	ZW499443	8-90		
SZ492941	22-29	ZW273778	1-73	ZW413256	1-11				
SZ510197	21-24x	ZW273778	3-13x	ZW413256	1-34				
UM472522	21-37	ZW273778	8-47x	ZW413256	1-81				
UM488924	7-2	ZW273778	8-92	ZW413278	8-35x				
ZG208091	8-95	ZW273778	21-32x	ZW413728	1-12				
ZG246857	1-75	ZW273778	21-41x	ZW413728	1-59				
ZG249107	22-13x	ZW273802	1-25x	ZW413741	8-45x				
ZG255633	3-7	ZW273802	11-9x	ZW413741	8-101				
ZG300431	4-11	ZW273960	8-21	ZW413741	8-153				
ZG303300	1-13	ZW274026	8-34x	ZW413741	11-8				
ZG303300	1-27	ZW290283	3-29	ZW413741	22-10x				
ZG303300	1-42	ZW290283	5-9	ZW413785	1-20				
ZG315011	3-30	ZW290283	8-74x	ZW413785	1-26				
ZG315011	8-80	ZW290283	8-145x	ZW414033	1-6x				
ZG317496	3-15	ZW290248	8-157x	ZW414066	8-61				
ZG317968	21-16x	ZW290250	8-158	ZW416687	8-42x				
ZG407575	8-146	ZW292667	4-9	ZW417025	1-83				
ZG409015	8-144	ZW313470	20-21x	ZW417137	5-10				
ZG428927	8-23	ZW317801	1-66x	ZW417137	8-63				
ZG465478	8-73	ZW321592	2-10	ZW417137	8-117				
ZG466154	6-48	ZW321592	4-4	ZW417137	22-5x				
ZG472770	5-8	ZW323728	3-28x	ZW417148	1-43				
ZG472994	8-86	ZW323728	5-20	ZW417148	1-85				
ZG473218	1-21	ZW323728	6-4	ZW417148	6-47				
ZG473321	1-46	ZW323728	6-8	ZW417150	7-38				
ZG473973	5-4	ZW323728	6-13	ZW417150	21-43x				
ZG810055	1-28	ZW323728	6-40x	ZW419646	22-40x				
ZW200362	20-4x	ZW323728	6-49	ZW419646	22-53x				
ZW200384	22-44x	ZW323728	7-22	ZW419747	2-3x				
ZW200610	8-159x	ZW323728	8-13x	ZW419793	1-14				
ZW200610	22-38x	ZW323728	8-49	ZW420682	5-7				
ZW200621	22-55x	ZW323728	8-52	ZW421806	11-4				
ZW201150	8-129x	ZW323728	8-57	ZW422965	8-59				
ZW201150	22-47x	ZW323728	8-67	ZW424056	3-19				
ZW201475	2-19	ZW323728	8-79	ZW424203	2-12				
ZW201835	8-5x	ZW323728	8-148	ZW424495	21-17x				
ZW201914	20-8	ZW323728	21-23x	ZW425733	8-31				
ZW201914	20-17	ZW324448	22-64x	ZW425981	3-16x				
ZW201971	16-2	ZW334653	4-3	ZW432685	1-40				
ZW202331	19-3	ZW345442	8-18	ZW432685	1-58				
ZW203084	22-46	ZW348107	21-18x	ZW433001	8-99				
ZW206021	2-6	ZW356883	2-11	ZW433001	22-61x				
ZW206021	4-6	ZW365973	3-18	ZW434160	22-20x				
ZW243516	8-94	ZW375153	21-5	ZW434250	1-4x				
ZW257477	1-78	ZW371856	5-15	ZW434283	22-54x				
ZW257477	8-7x	ZW371856	6-20x	ZW439514	1-19				
ZW257477	8-15	ZW371856	7-34x	ZW439514	8-56				
ZW259334	20-14x	ZW371856	21-21x	ZW439661	22-35x				
ZW259413	6-22x	ZW374128	8-130x	ZW440291	7-35x				
ZW259648	1-37	ZW375963	1-33	ZW442585	6-17				
ZW259683	8-135	ZW383152	20-26	ZW444273	5-12				
ZW259806	22-50x	ZW383332	20-19x	ZW444273	8-108x				
ZW260188	1-44	ZW383343	20-28	ZW447772	21-40				
ZW260256	4-10	ZW383883	22-14x	ZW447761	8-131x				
ZW269785	20-16x	ZW391476	2-7x	ZW447963	22-33x				
ZW270088	1-79	ZW392940	11-3	ZW461935	1-65				
ZW270088	3-9	ZW397157	8-91	ZW462194	7-31x				
ZW270088	6-39	ZW398125	2-5	ZW468112	7-11				
ZW270088	6-46	ZW398158	2-14	ZW472274	6-14				
ZW270088	8-8x	ZW403222	3-20	ZW472274	6-24				
ZW270088	8-17x	ZW403525	2-13	ZW472274	7-5				
ZW270088	8-29	ZW403536	2-15	ZW472983	8-87				
ZW270088	8-136x	ZW403571	22-41x	ZW477876	1-9				
ZW270101	1-51	ZW408418	22-45	ZW482545	8-70				
ZW270101	6-7	ZW410231	21-31x	ZW482635	5-5				
ZW270101	8-19x	ZW413155	1-23	ZW482657	22-21x				
ZW270101	8-71	ZW413155	1-60	ZW482736	1-15				
ZW270101	8-88x	ZW413155	2-20	ZW482758	1-38				
ZW270134	1-48	ZW413155	8-93	ZW482815	22-49				
ZW273363	8-89	ZW413155	8-102	ZW482927	21-4x				
ZW273633	8-142	ZW413155	10-3x	ZW484828	8-143				
ZW273690	20-29	ZW413155	11-7x	ZW487833	22-51x				
ZW273756	1-80	ZW413155	11-11x	ZW487844	22-59x				
ZW273756	8-39x	ZW413155	15-3	ZW487866	22-27x				
ZW273756	11-5	ZW413155	21-46x	ZW487912	4-13				
ZW273756	15-4x	ZW413188	3-22x	ZW490228	7-13				
ZW273756	16-5x	ZW413188	8-37x	ZW490228	7-20				

---

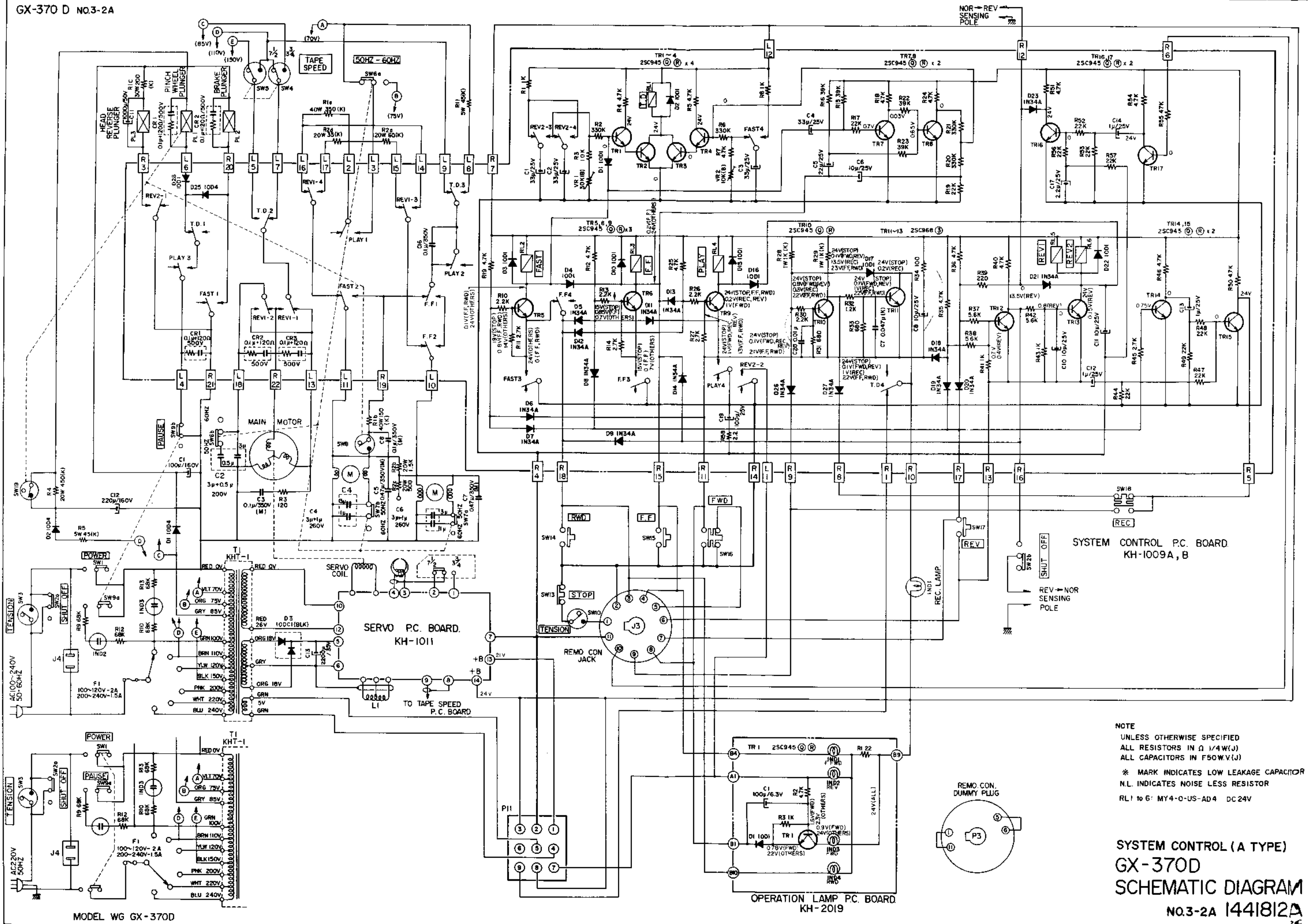
SECTION 3  
**SCHEMATIC DIAGRAM**

GX-370D SCHEMATIC DIAGRAM



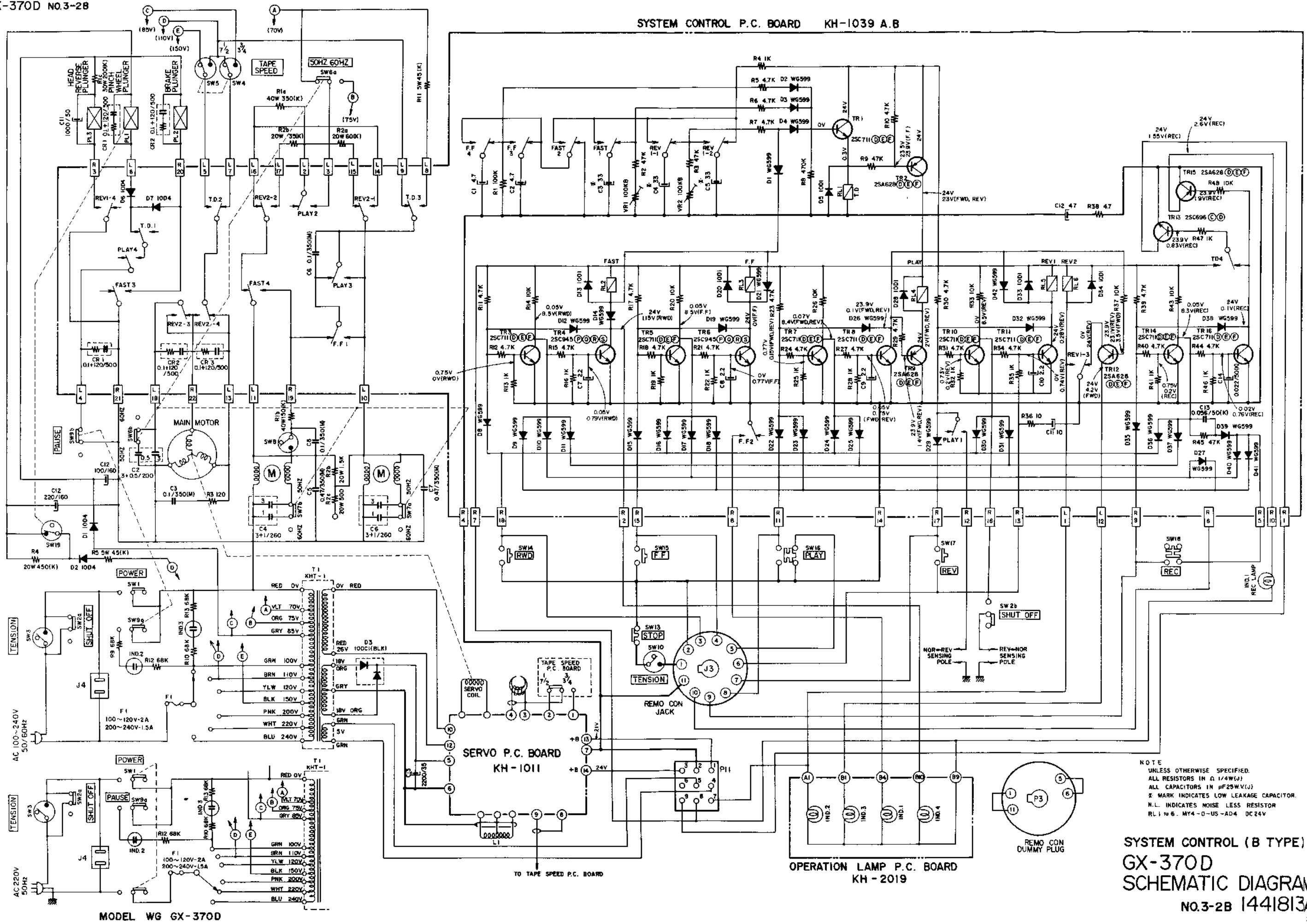


NOTE  
 UNLESS OTHERWISE SPECIFIED  
 ALL RESISTORS 1/4W(J)  
 ALL CAPACITORS IN F50W.V.(J)  
 \* MARK INDICATES LOW LEAKAGE CAPACITOR  
 N.L. INDICATES NOISE LESS RESISTOR



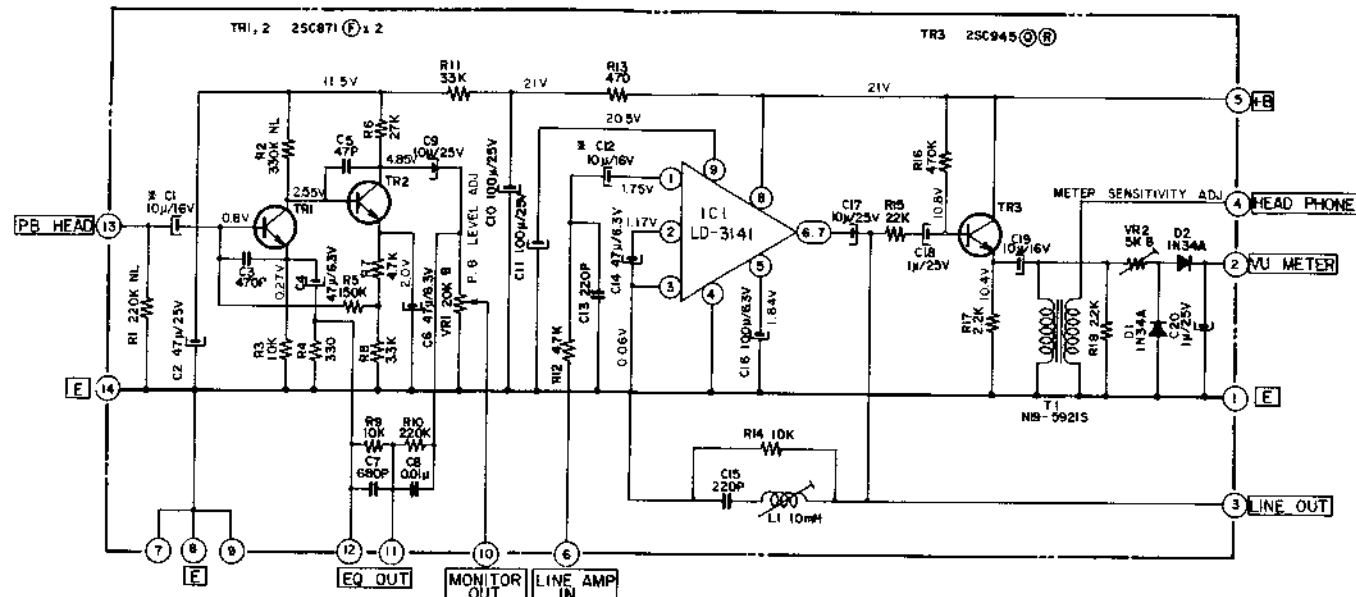
NOTE  
 UNLESS OTHERWISE SPECIFIED  
 ALL RESISTORS IN Ω 1/4W.(J)  
 ALL CAPACITORS IN F50W.V.(J)  
 \* MARK INDICATES LOW LEAKAGE CAPACITOR  
 N.L. INDICATES NOISE LESS RESISTOR  
 RL1 TO 6: MY4-0-US-AD4 DC 24V

SYSTEM CONTROL (A TYPE)  
 GX-370D  
 SCHEMATIC DIAGRAM  
 NO.3-2A 1441812A

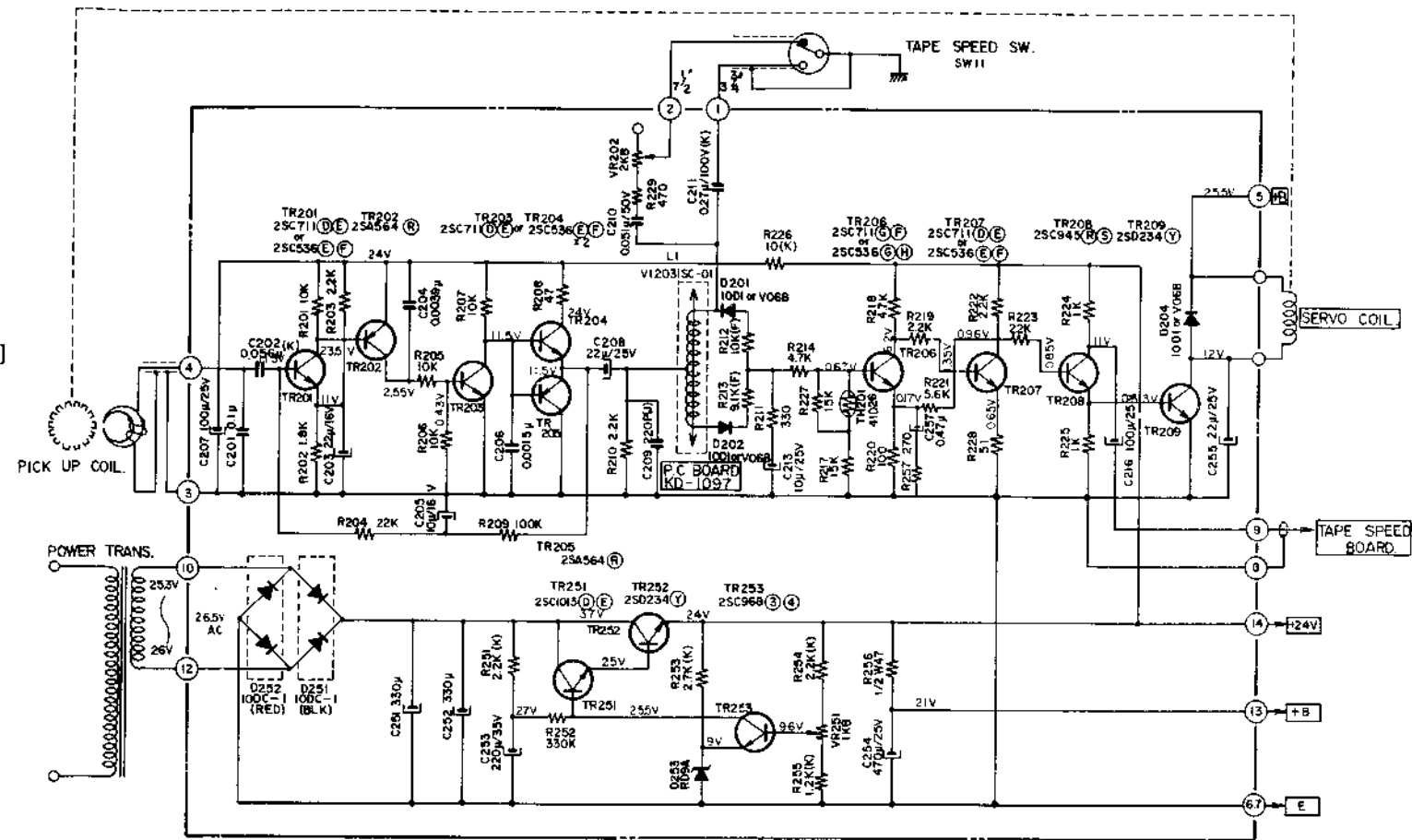


NOTE  
 UNLESS OTHERWISE SPECIFIED:  
 ALL RESISTORS IN Ω/1/4W(J)  
 ALL CAPACITORS IN μF/250V(J)  
 \* MARK INDICATES LOW LEAKAGE CAPACITOR.  
 N.L. INDICATES NOISE LESS RESISTOR  
 RL1 to 6, MY4-0-US-AD4 DC24V

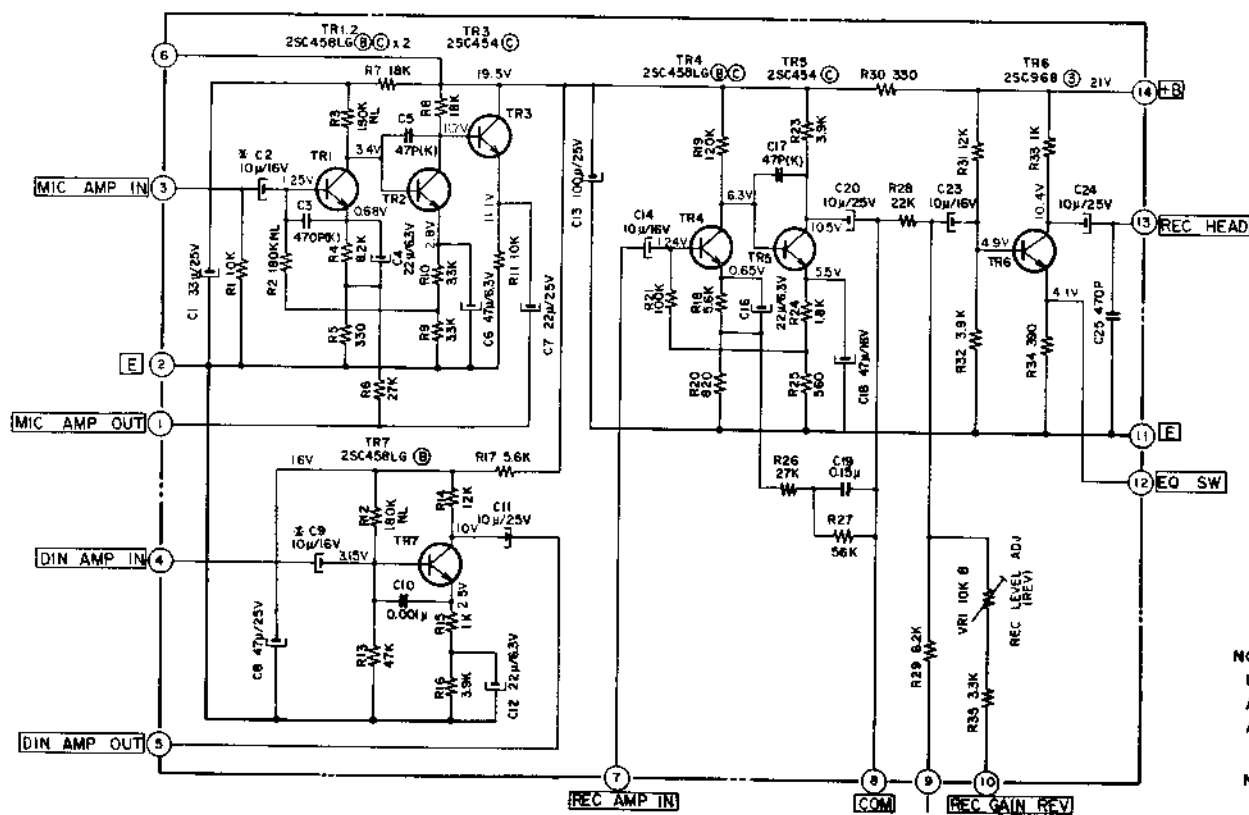
SYSTEM CONTROL (B TYPE)  
 GX-370D  
 SCHEMATIC DIAGRAM  
 NO.3-2B 1441813A



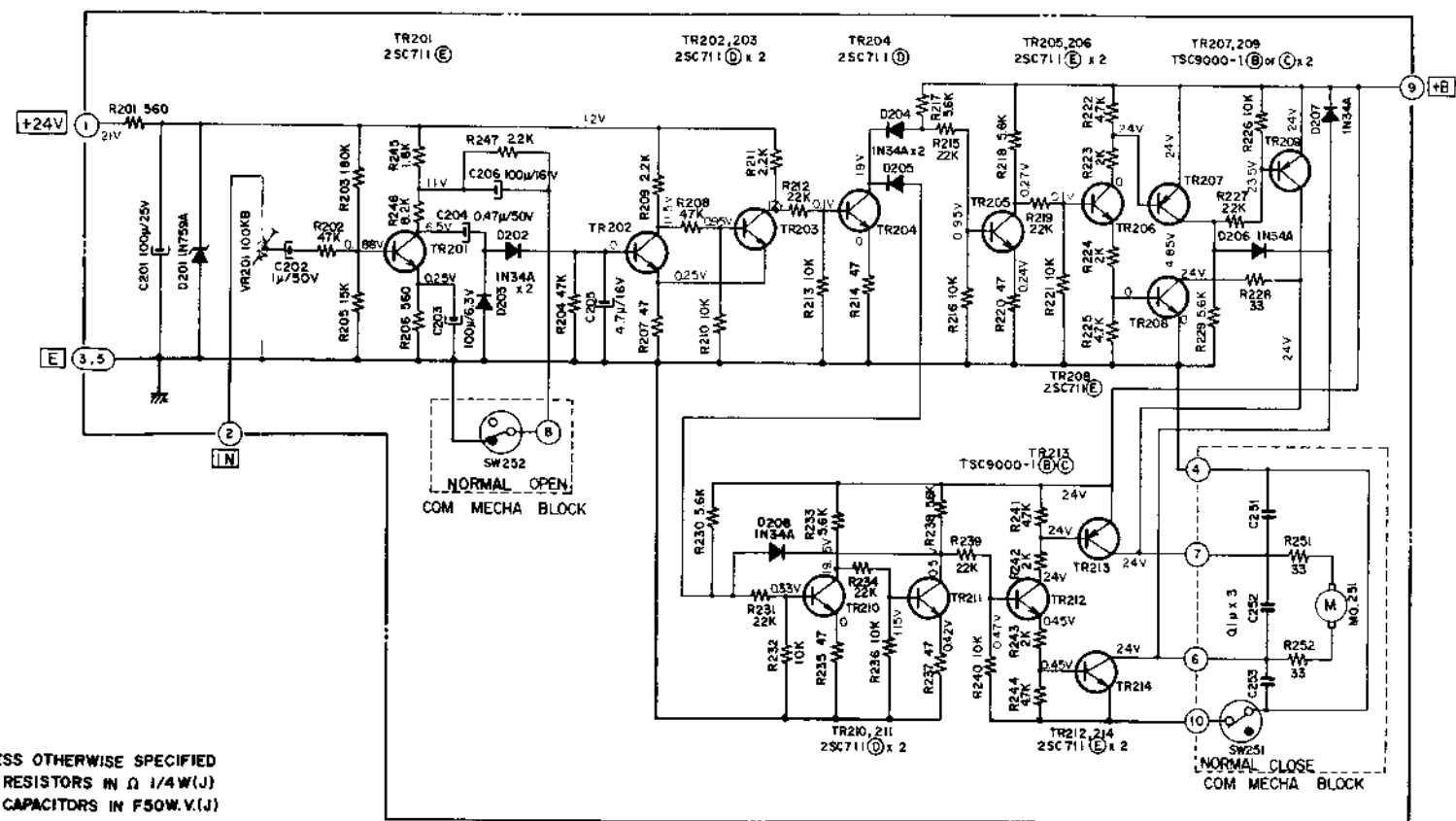
P. B. AMP P. C. BOARD KH-5014



SERVO P. C. BOARD KH-1011



REC AMP P. C. BOARD KH-5013



COM DET P. C. BOARD RD-A514

NOTE  
 UNLESS OTHERWISE SPECIFIED  
 ALL RESISTORS IN  $\Omega$  1/4W(J)  
 ALL CAPACITORS IN F50W.V(J)  
 \* MARK INDICATES LOW LEAKAGE CAPACITOR  
 NL. INDICATES NOISE LESS RESISTOR