



4-CH/STEREO TAPE DECK

MODEL GX-400D-SS

THIS MANUAL MUST BE USED AS A SET TOGETHER WITH
SEPARATELY PUBLISHED GX-400D SERVICE MANUAL
AND PARTS LIST

SECTION 1	SERVICE MANUAL	2
SECTION 2	PARTS LIST	23
SECTION 3	SCHEMATIC DIAGRAM	36

SECTION 1

SERVICE MANUAL

Except for the parts which have been changed as per List 1 below, the composite parts of Model GX-400D-SS are identical to those of Model GX-400D. Therefore, for general repairs and adjustments etc., please refer to GX-400D Service Manual

TABLE OF CONTENTS

I. REFERENCE FOR REPAIR AND ADJUSTMENT OF MODEL GX-400D-SS	3
II. SPECIFICATIONS	4
III. HEAD ADJUSTMENT	6
IV. AMP. SYSTEM ADJUSTMENTS	7
V. D.C. RESISTANCES OF VARIOUS COILS	16
VI. COMPOSITE VIEWS OF COMPONENTS	17

I. REFERENCE FOR REPAIR AND ADJUSTMENT OF MODEL GX-400D-SS

When making adjustment on repairs of Model GX-400D-SS Mechanism System or for Measurement Methods, Sys. Con., A.C. Servo Operating. Principals, etc., kindly refer to the following sections of Model GX-400D Service Manual:

Measuring Method: Pages 8 and 9

Mechanism Adjustment: Pages 12 through 19

Explanation of A.C. Servo Control Operation:
Pages 31 through 34

Transport Mechanism: Pages 37 through 40

CLASSIFICATION AND INTERCHANGEABILITY OF VARIOUS P.C. BOARDS

P.C. Boards	Models		
	GX-400D-SS	GX-400D	GX-400D-PRO
Servo Control P.C. Board	TW-1049	TW-1049	TW-1049
System Control P.C. Board	TW-1048	*TW-1048	TW-1201
System Control (B) P.C. Board	TW-1301	-----	-----
Power Supply P.C. Board	TW-2018	TW-2018	TW-2018
Direction P.C. Board	TW-2057	-----	TW-2057
P.B. Amp. P.C. Board	TW-5314	TW-5032	*TW-5032
Rec. Amp. P.C. Board	NS-5023	-----	-----
Rec. Amp. & ADR P.C. Board	-----	TW-5206	*TW-5206
Osc. P.C. Board	TW-5313	TW-5033	TW-5204
EQ. SW. P.C. Board	TW-5310	TW-5028	TW-5028
Volume P.C. Board	TW-5323	TW-5030	TW-5030
Selector P.C. Board	TW-5311	-----	-----
Track Selector P.C. Board	-----	TW-5026	-----
P.B. Mode P.C. Board	-----	-----	TW-5203
Dummy P.C. Board	TW-5315	-----	-----
SRT SW. P.C. Board	-----	TW-5029	*TW-5029
Headphone P.C. Board	TW-5312	-----	-----
Monitor SW. P.C. Board	-----	TW-5027	TW-5027
Chassis P.C. Board	-----	TW-5025	-----

NOTE: * ... No Interchangeable

II. SPECIFICATIONS

An asterisk next to a figure indicates the minimum guaranteed performance.

TRACK SYSTEM	4 track 4 channel stereo, monaural Recording/Playback	
TAPE SPEED	15, 7-1/2 and 3-3/4 ips. \pm 1.5%	
WOW AND FLUTTER	Less than 0.035% (*0.06%) R.M.S. at 15 ips. Less than 0.05% (*0.09%) R.M.S. at 7-1/2 ips. Less than 0.08% (*0.15%) R.M.S. at 3-3/4 ips.	
FREQUENCY RESPONSE	<p>LOW NOISE TAPE (S.R.T. TAPE etc.)</p> <p>20 to 27,000 Hz (*30 to 25,000 Hz\pm3 dB) at 15 ips. 20 to 26,000 Hz (*30 to 24,000 Hz\pm3 dB) at 7-1/2 ips. 30 to 18,000 Hz (*30 to 15,000 Hz\pm3 dB) at 3-3/4 ips.</p> <p>NORMAL TAPE (FUJI S-100 etc.)</p> <p>20 to 26,000 Hz (*30 to 24,000 Hz\pm3 dB) at 15 ips. 20 to 24,000 Hz (*30 to 22,000 Hz\pm3 dB) at 7-1/2 ips. 30 to 16,000 Hz (*30 to 13,000 Hz\pm3 dB) at 3-3/4 ips.</p>	
TOTAL DISTORTION FACTOR	*Less than 2% at 1,000 Hz 0 VU recording (SCOTCH #111 Tape)	
OUTPUTS	LINE OUTPUT	4 \pm 1 dB/FWD, 4 \pm 1.5 dB/REV using a 15 ips. 7000 Hz 0 VU recorded tape at 15 ips.
	DIN OUTPUT	0.6V
	HEADPHONE OUTPUT	50 \pm 10 mV(8 Ω load), 1,000 Hz 0 VU at Headphone Volume Maximum
INPUTS	MIC INPUT	0.5 mV
	LINE INPUT	100 mV
	DIN INPUT	10 mV(Low), 60 mV(High)
RECORDING/PLAYBACK LEVEL	4 \pm 1.5 dB, 1,000 Hz 0 VU recording at 7-1/2 ips. (SCOTCH #111 Tape)	
SIGNAL TO NOISE RATIO	*Better than 48 dB Normal *Better than 40 dB Quadra Sync.	
CROSS TALK	Better than 40 dB at 1,000 Hz 3 VU recording	
ERASE RATIO	Better than 70 dB at 1,000 Hz 3 VU recording	
RECORDING BIAS FREQUENCY	100 \pm 5 kHz	
BIAS LEAK	Less than -20 VU	
REVERSING TIME	Within 4 sec. at 15 ips. Within 3 sec. at 7-1/2 ips, 3-3/4 ips.	
F.FWD AND RWD TIME	120/100 sec. using a 2,400 ft. tape at 50/60 Hz	
MOTORS	CAPSTAN MOTOR	4 pole eddy current A.C. servo motor Type: SCM3-16 TW Revolutions: 800 r.p.m. at 15 ips. 400 r.p.m. at 7-1/2 ips. 200 r.p.m. at 3-3/4 ips.
	REEL MOTOR	Two 6 pole eddy current inner rotor motors. Type: IM-24TW Revolutions: 1,000/1,200 r.p.m. at 50/60 Hz
HEADS	ERASE HEAD	Type: E4-260 Gap: 0.6 mm Impedance: 195 Ω \pm 10% D.C. Resistance: 3.5 Ω at 100 kHz
	RECORDING HEAD	Type: R4-285 Gap: 4 micron \pm 15% Impedance: 16 Ω \pm 15% at 1 kHz D.C. Resistance: 13 Ω
	PLAYBACK HEAD	Type: P4-280 Gap: 1.7 micron \pm 15% Impedance: 1,346 Ω at 1 kHz D.C. Resistance: 350 Ω
TRANSISTORS	2SA564(Q)(R) . . . 3 2SA628(D)(E) . . . 4 2SA696 . . . 1 2SC458LG(C) . . . 20 2SC711(D)(E)(F) . . . 46 2SC711(E2) . . . 2 2SC792 . . . 1	2SC945(Q)(R) . . . 2 2SC968(2)(3) . . . 3 2SC971 . . . 1 2SC1014(C)(D) . . . 1 2SC1211(C)(D) . . . 1 2SC1247A(B)(V)(Y) . . . 9 2SD234(Q)(R) . . . 1

I.C.	LD3141 . . . 4
DIODES	1S1588 . . . 56 10D05 . . . 12 10D1 . . . 6 10D4 . . . 7 WG713 . . . 6 10DC2(Blk) . . . 1 10DC2(Red) . . . 1 5B2 . . . 1
ZENER DIODES	WZ065 . . . 1 YZ088A . . . 2 RD7A(L) . . . 3 RD9A(L) . . . 4
THERMISTER	31D26 . . . 1
POWER SUPPLY	100 to 240V A.C. 50/60 Hz
POWER CONSUMPTION	160W maximum
INSULATION RESISTANCE	More than 50 MΩ
DIMENSIONS	457(W)x590(H)x240(D)mm (18"x23.2"x9.5")
WEIGHT	31.2 kg (68.7 lbs.)

NOTE: Specifications subject to change without notice.

III. HEAD ADJUSTMENT

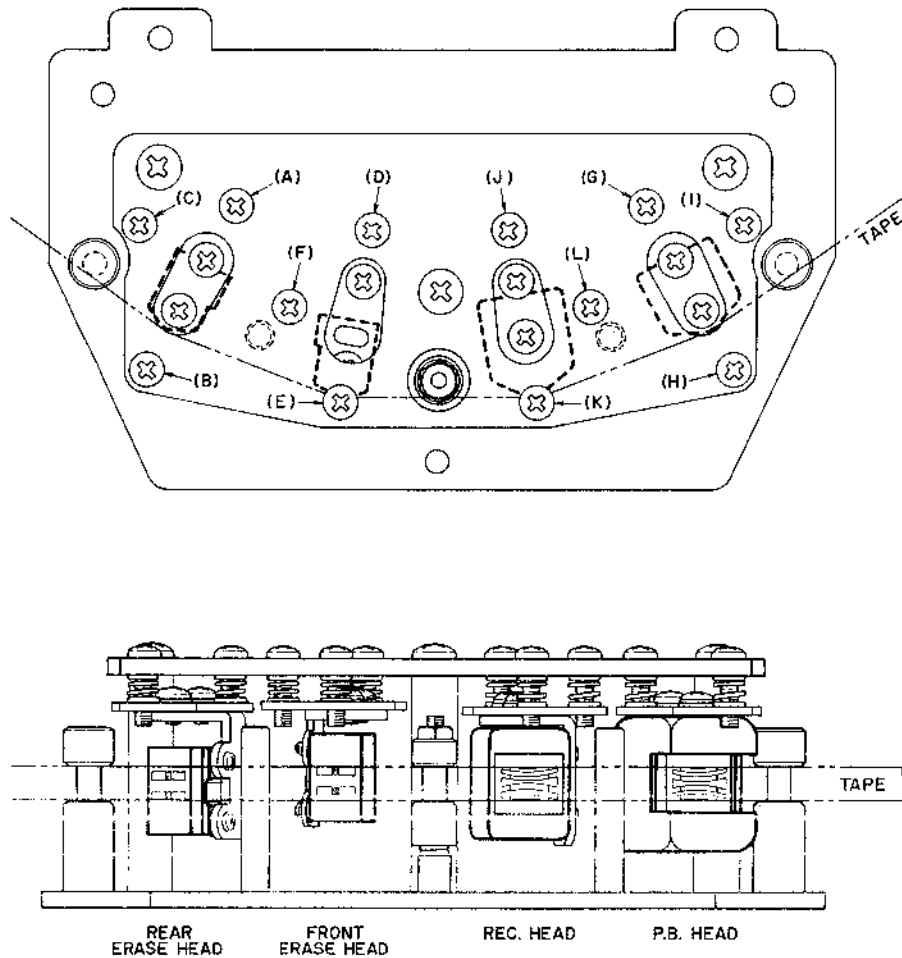

Fig. 1

Adjustment Items	Test Tape Supply Signal	Measuring Instrument Connection	Mode	Tape Speed	Adjustment Screw	Remarks
Rear CH. Erase Head Height Adjustment	Optional	/	FWD	Optional	(A)(B)(C)	Even Lower Edge of CH.4 Head core and Lower edge of tape
Front CH. Erase Head Height Adjustment	Optional	/	FWD	Optional	(D)(E)(F)	Even Upper edge of CH.1 Head core and Upper edge of Tape
Recording Head Height Adjustment	Optional	/	FWD	Optional	(J)(K)(L)	Even Upper edge of CH.1 Head core and Upper edge of Tape
Playback Head Height Adjustment	Optional	/	FWD	Optional	(G)(H)(I)	Even Upper edge of CH.1 Head core and Upper edge of Tape
Playback Head Azimuth Alignment Adjustment	15,000 Hz 15 ips. Test Tape	High Sensitivity V.T.V.M. to Line Output	FWD	15 ips.	(I)	Maximum Line Output Level on All Channels
Recording Head Azimuth Alignment Adjustment	15,000 Hz -16 dB Signal to Line Input	Audio Frequency Oscillator to Line Input and High Sensitivity V.T.V.M. to Line Output	REC	15 ips.	(L)	Maximum Line output Level on All Channels

Chart 1

IV. AMP. SYSTEM ADJUSTMENTS

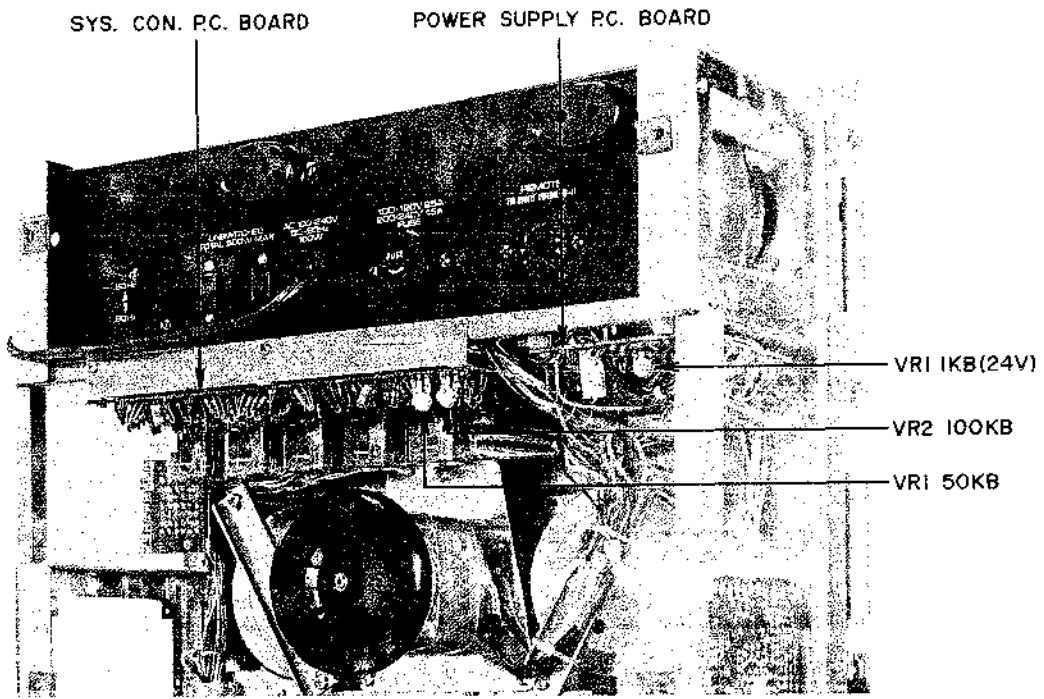

Fig. 2

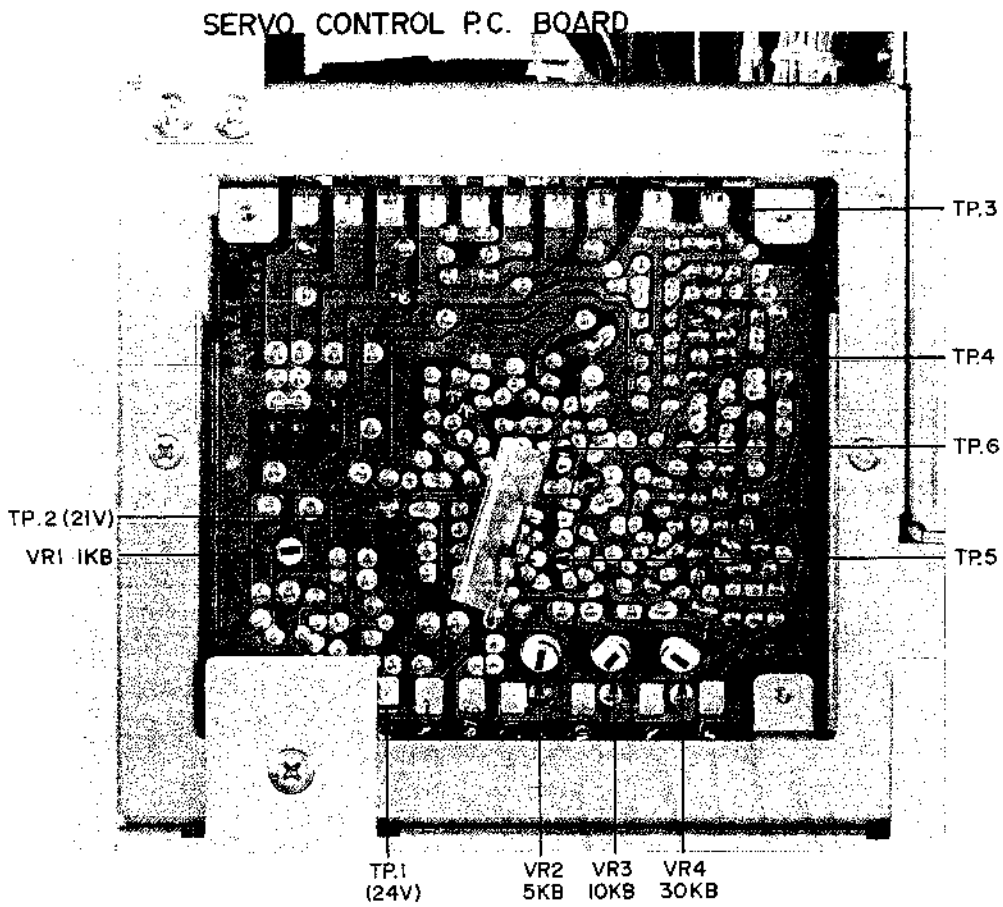

Fig. 3

HEAD PHONE P.C. BOARD TW-5312

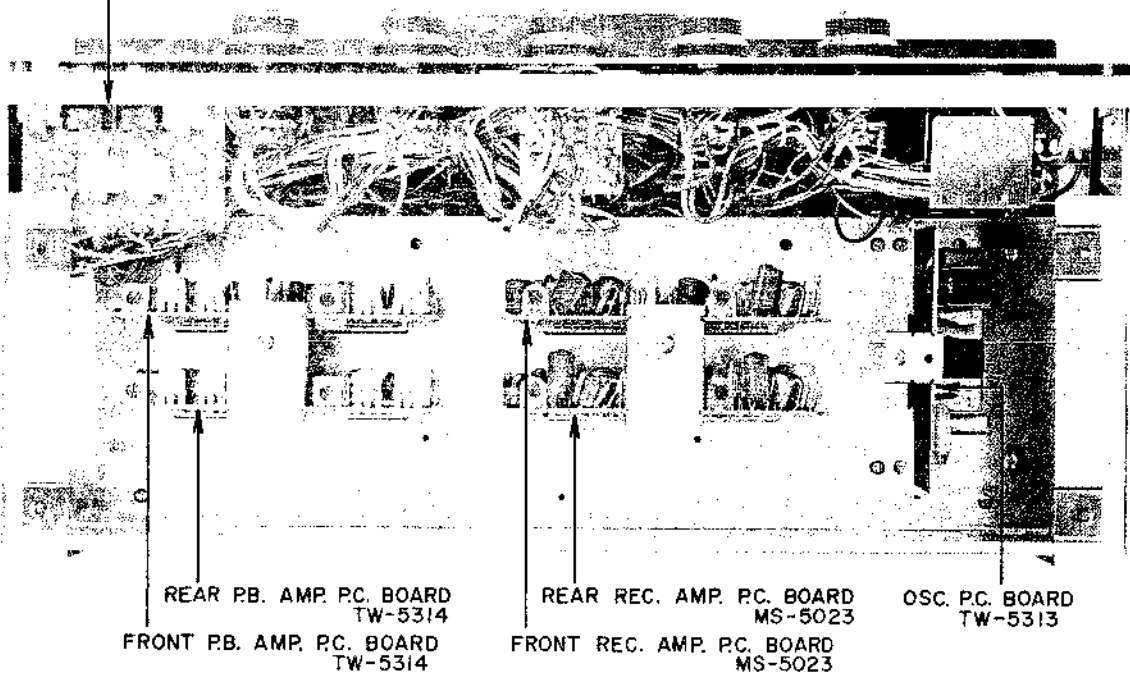

Fig. 4

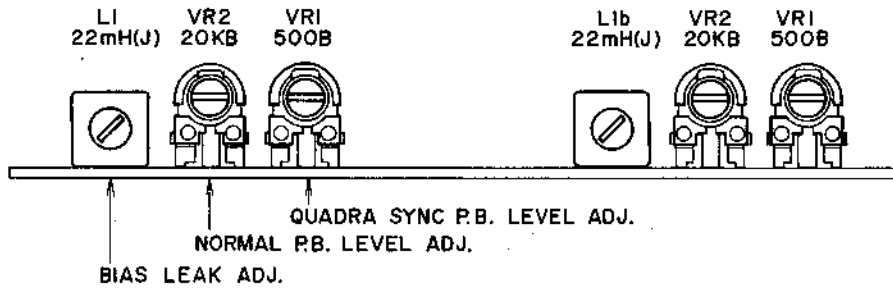

Fig. 5 P.B. AMP. P.C. BOARD TW-5314

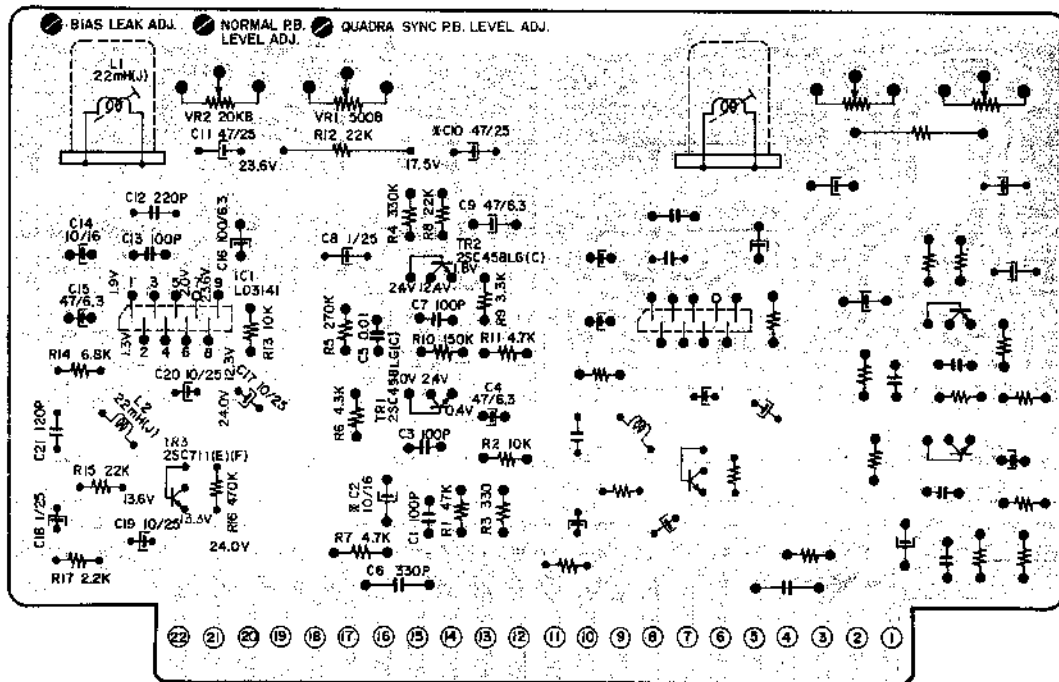

Fig. 6 P.B. AMP. P.C. BOARD TW-5314 (REVERSE)

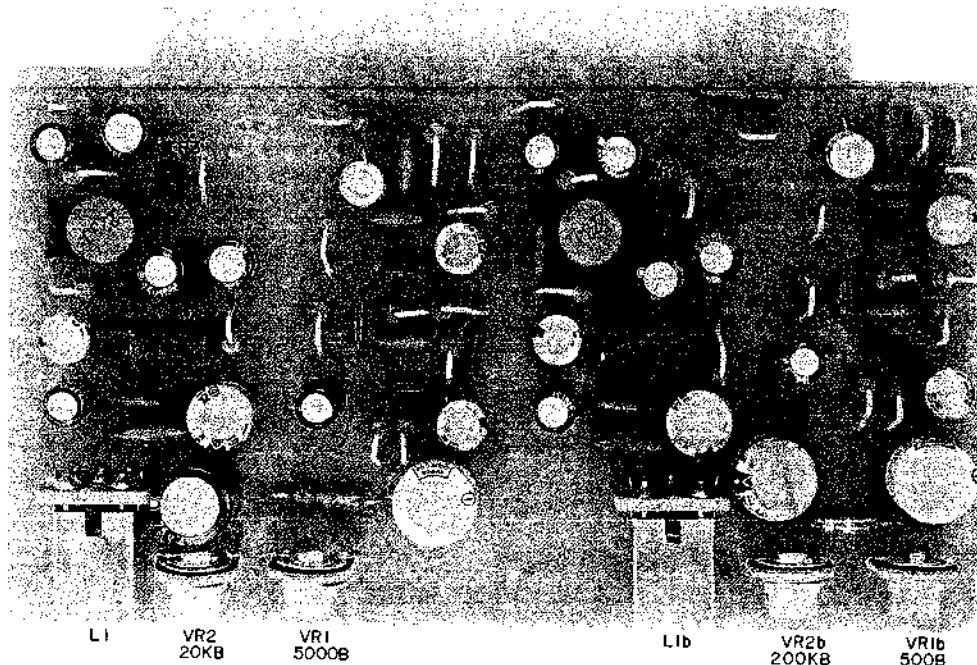

Fig. 7 P.B. AMP. P.C. BOARD TW-5314 (FACE)



Fig. 8 REC. AMP. P.C. BOARD MS-5023

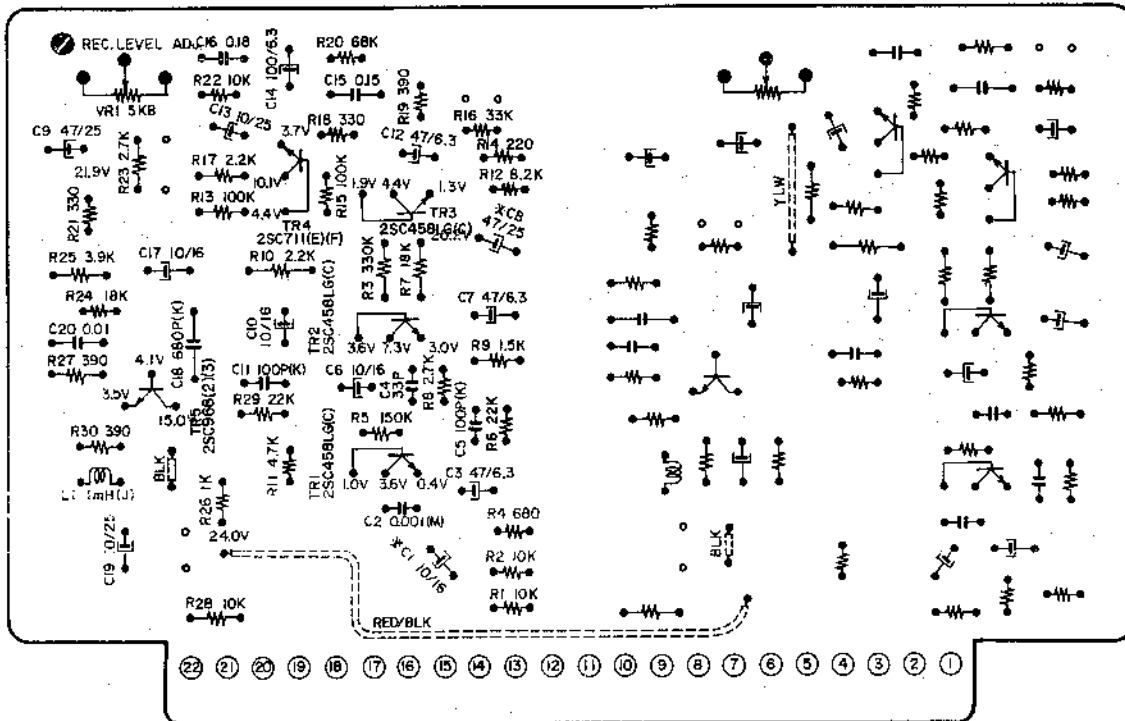

Fig. 9 REC. AMP. P.C. BOARD MS-5023 (REVERSE)

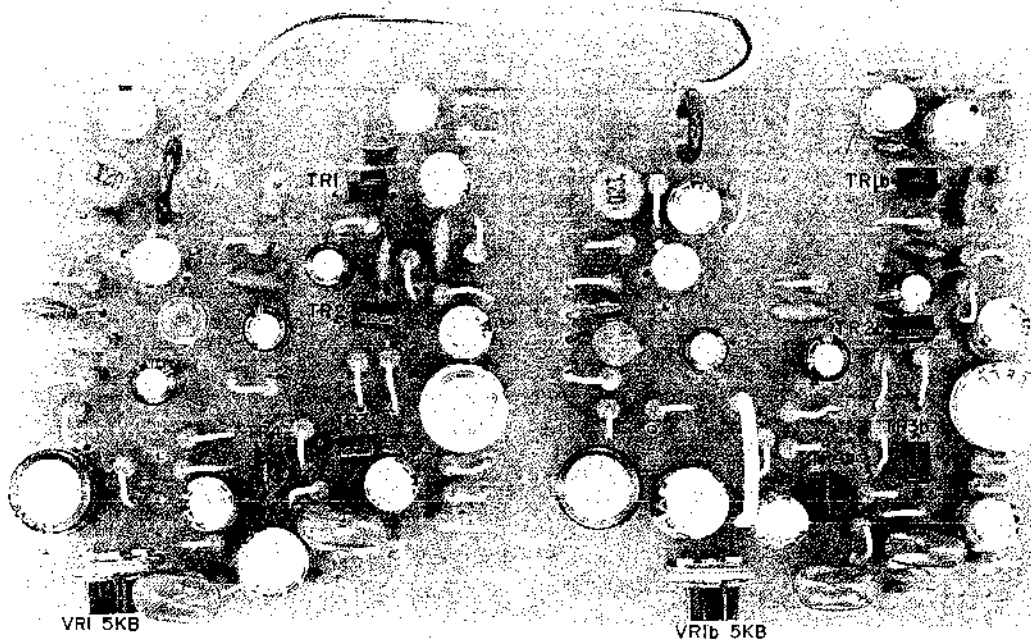

Fig. 10 REC. AMP. P.C. BOARD MS-5023 (FACE)

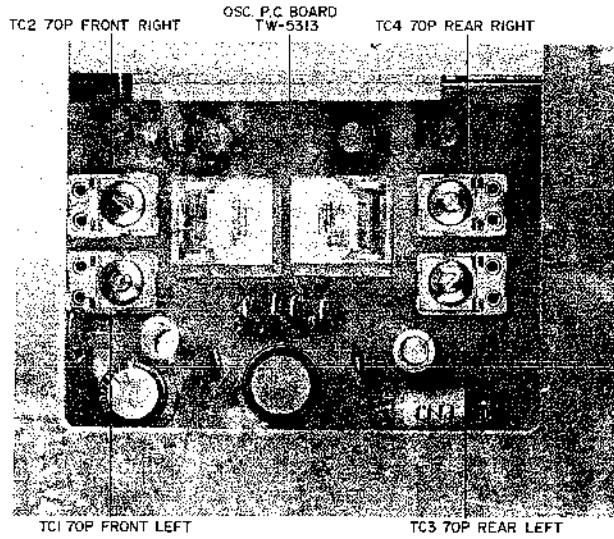

Fig. 11

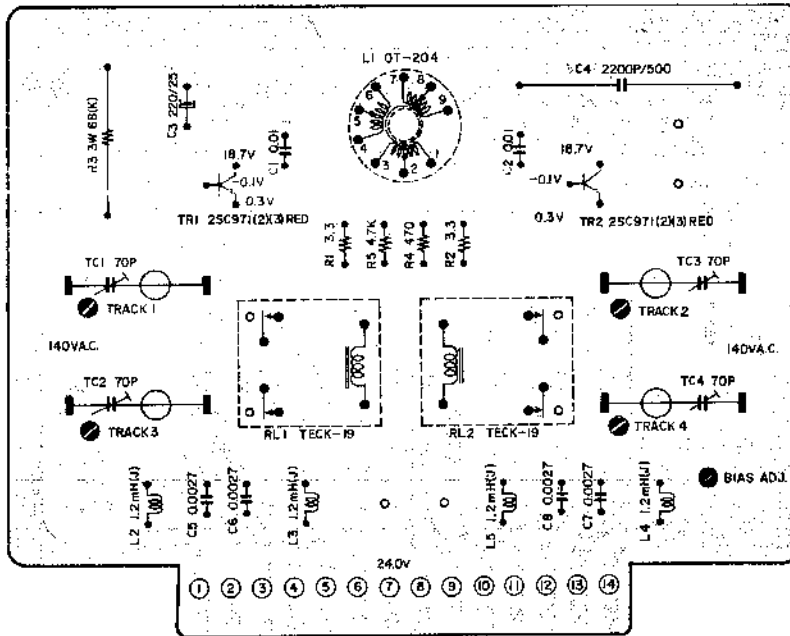

Fig. 12 OSC. P.C. BOARD TW-5313 (REVERSE)

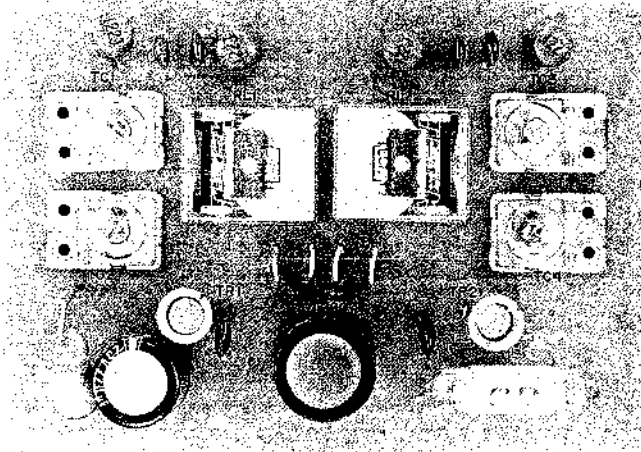

Fig. 13 OSC. P.C. BOARD TW-5313 (FACE)

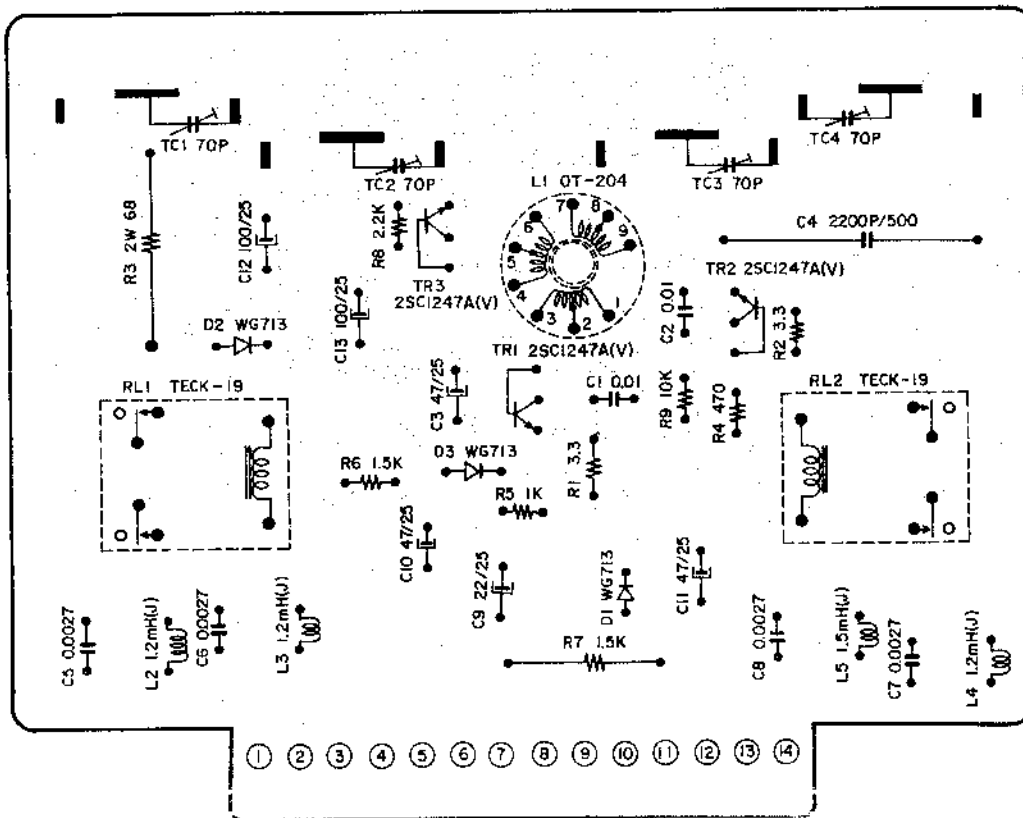

Fig 14 OSC P.C. BOARD TW-5313-2ED (REVERSE)

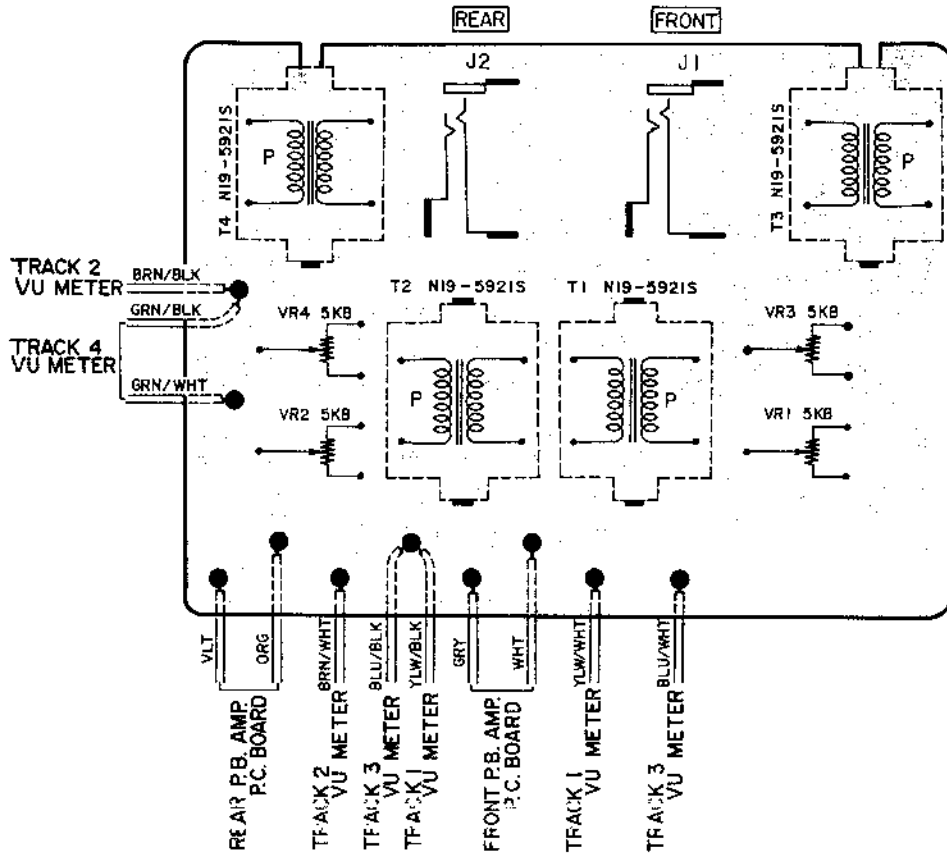

Fig. 15 HEAD PHONE P.C. BOARD TW-5312 (REVERSE)

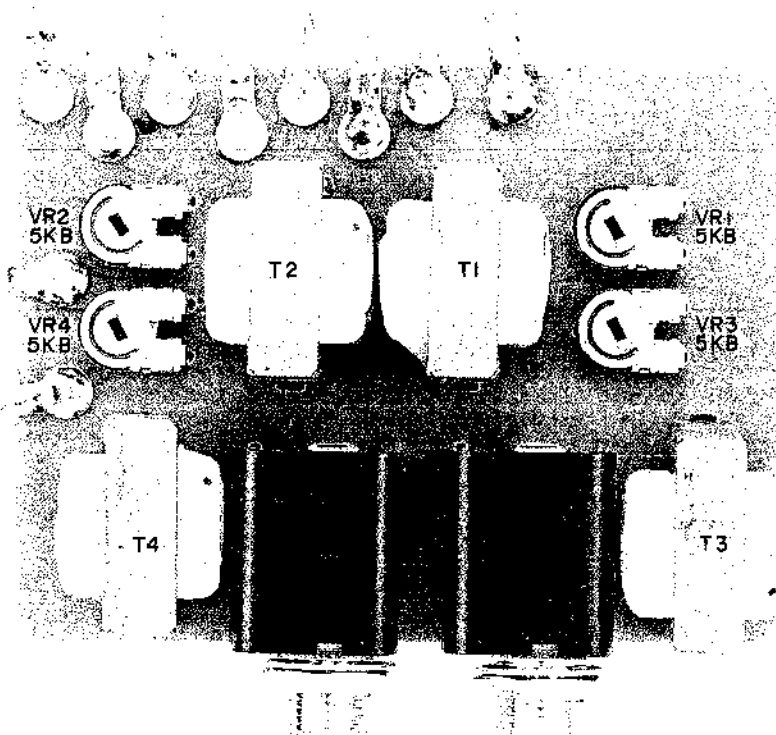

Fig. 16 HEAD PHONE P.C. BOARD TW-5312 (FACE)

Adjustment Item	Test Tape Supply Signal	Measuring Instrument Connection	Mode	Tape Speed	Adjustment	Result	Ref. Diagram	Remarks
Power Source Circuit Voltage Adjustment		V.T.V.M. or Tester between TP.1 and Ground	STOP		VR1 1 k Ω	24V	Fig. 2	TP. 1 (See Fig. 3)
Servo Control Circuit Voltage Adjustment		V.T.V.M. or Tester between TP.2 and Ground	STOP		VR1 1 k Ω	21V	Fig. 3	Must First be Adjusted to 24 V
15 ips. (38 cm/sec.) Tape Speed Adjustment	1,000 Hz 7-1/2 ips. Test Tape	Frequency Counter to Line Output	FWD	15 ips.	VR2 5 k Ω	2,000Hz $\pm 1.5\%$	Fig. 3	
7-1/2 ips. (19 cm/sec.) Tape Speed Adjustment	1,000 Hz 7-1/2 ips. Test Tape	Frequency Counter to Line Output	FWD	7-1/2 ips.	VR3 10 k Ω	1,000Hz $\pm 1.5\%$	Fig. 3	
3-3/4 ips. (9.5 cm/sec.) Tape Speed Adjustment	1,000 Hz 7-1/2 ips. Test Tape	Frequency Counter to Line Output	FWD	3-3/4 ips.	VR4 30 k Ω	500Hz $\pm 1.5\%$	Fig. 3	
NORMAL Playback Level Adjustment	700 Hz 15 ips. Test Tape	High Sensitivity V.T.V.M. to Line Output	FWD	15 ips.	VR2 20 k Ω	4 ± 1 dB/FWD 4 ± 1.5 dB/RWD	Figs. 4,5	
QUADRA SYNC Playback Level Adjustment	700 Hz 15 ips. Test Tape	High Sensitivity V.T.V.M. to Line Output	FWD	15 ips.	VR1 500 Ω	4 ± 1 dB/FWD 4 ± 1.5 dB/RWD	Figs. 4,5	Depress QUADRA SYNC Switches
VU Meter Sensitivity Adjustment	700 Hz 15 ips. Test Tape		FWD	15 ips.	VR1 to VR4 5 k Ω	0 VU	Fig. 4	VR1 TRACK 2 VR2 TRACK 4 VR3 TRACK 1 VR4 TRACK 3
Recording Bias Adjustment	1,000/ 10,000 Hz -16 dB Signal to Line Input	Audio Frequency Oscillator to Line Input and High Sensitivity V.T.V.M. to Line Output	REC	3-3/4 ips.	TC1 to TC4 70 Pf	Flat Frequency Response	Fig. 11	TC1 TRACK 1 TC2 TRACK 3 TC3 TRACK 2 TC4 TRACK 4
Recording Level Adjustment	1,000 Hz Signal	Audio Frequency Oscillator to Line Input and High Sensitivity V.T.V.M. to Line Output	REC	7-1/2 ips.	VR1 5 k Ω	4 ± 1.5 dB	Figs. 4,8	VU Meter Indicates 0 VU
Bias Leak Adjustment		High Sensitivity V.T.V.M. to Line Output	REC	7-1/2 ips.	L1 22 mH(J)	Less than -20 VU	Figs. 4,5	
Direct Function Time constant Adjustment			FWD → ← REV	15 ips	VR1 50 k Ω	Within 3 sec.	Fig. 2	
			F.F or RWD → ← RWD or F.F	15 ips.	VR2 100 k Ω	Within 3 sec.	Fig. 2	

Chart 2

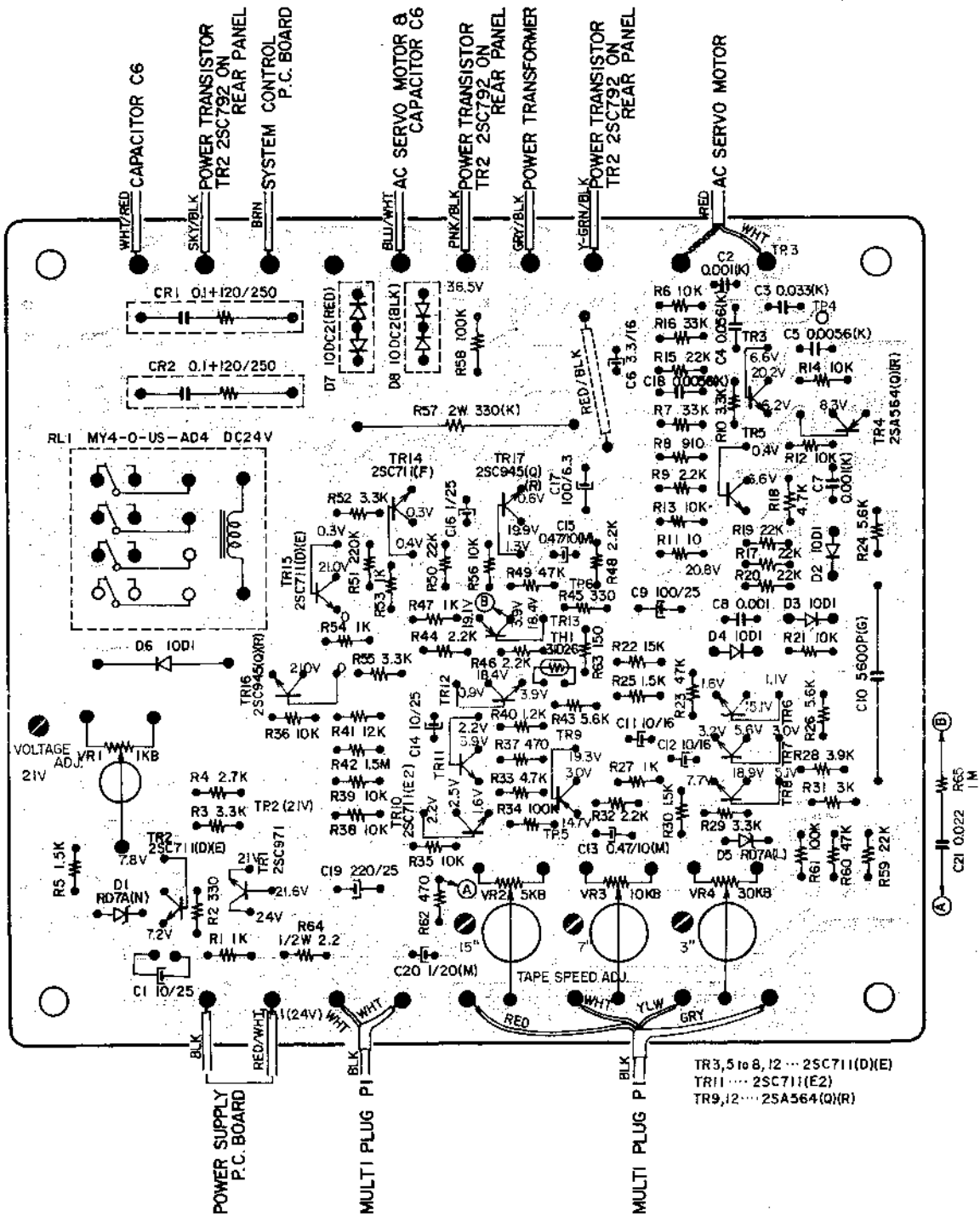

Fig. 17. SERVO CONTROL P.C. BOARD TW-1049 (REVERSE)

NOTE: For Explanation of A.C. Servo Control Operation, refer to GX-400D Service Manual, Pages 31 through 34.

V. D.C. RESISTANCES OF VARIOUS COILS

The D.C. resistance values shown below are average values.

Designation	Type	D.C. Resistance
Capstan Motor	SCM3-16TW	Between RED-BLU 19Ω Between YLW-GRN 90Ω
Reel Motor	IM1-24TW	Between RED-BLU 30Ω Between YLW-GRN 157Ω
Pinch Wheel Solenoid	1660PHT2	750Ω
Brake Solenoid	1660THT2	700Ω
Shifter Solenoid	1254THT	620Ω
Pick-up Coil	Built in Capstan Motor	3.7 kΩ
Erase Head	E2-100	2.5Ω
Recording Head	R4-280	13Ω
Playback Head	P4-280	350Ω
Relay	MY4-0-US-AD4 D.C. 24V TECK-19	650Ω 1,500 Ω
Headphone Transformer	N19-5921S	Primary 230Ω Secondary 0.9Ω
OSC. Transformer	OT-204	Between 1-3 0.3Ω Between 4-6 0.7Ω Between 7-9 8.2Ω
Power Transformer	TWT-2	Refer to Fig. 18

Chart 3

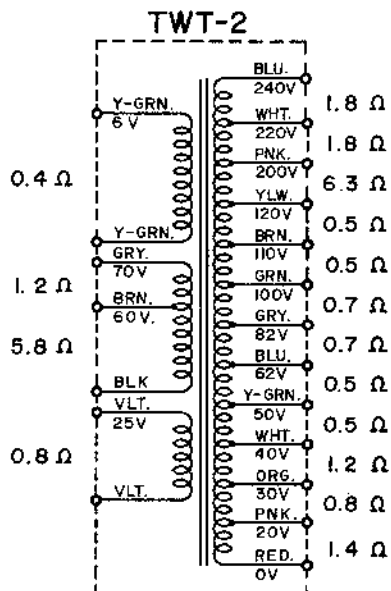
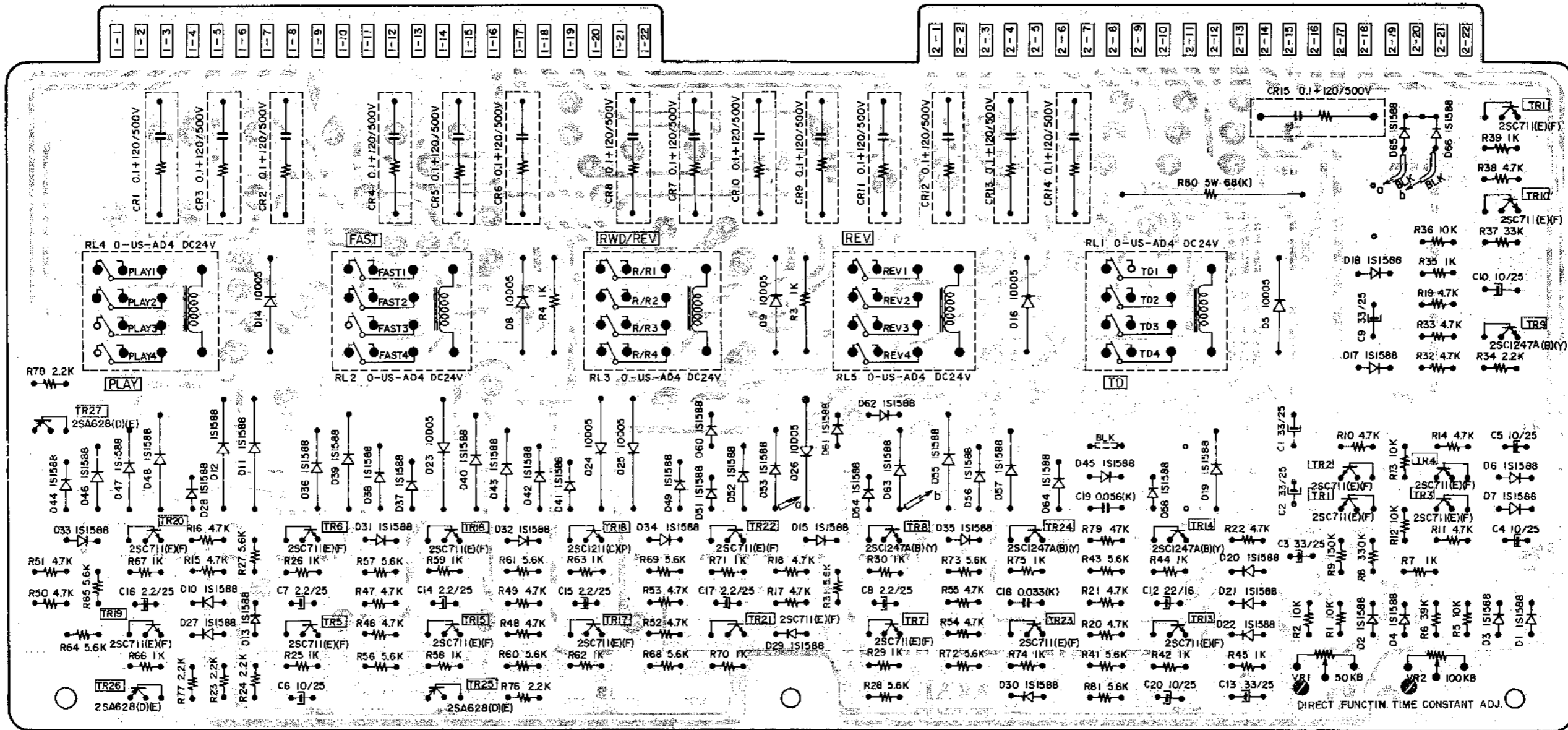

Fig. 18

VI. COMPOSITE VIEWS OF COMPONENTS

1. SYS. CON. P.C. BOARD TW-1048



TRANSISTOR	TR 1	TR 2	TR 3	TR 4	TR 5	TR 6	TR 7	TR 8	TR 9	TR 10	TR 11	TR 13	TR 14
E	0		0 (STOP) 0.3V (FF, RWD) 0.2V (OTHER)	0 (STOP) 0.3V (FF, RWD) 0.2V (OTHER)						15.1V (REV) 0 (OTHER)			
C	24.0V	24.0V	24.0V	24.0V	0 (STOP, FF, RWD) 10.1V (FWD, REV) 12.8V (REC)	24.0V (STOP, FF, RWD) 0.2V (OTHER)	10.1V (REV) 0 (OTHER)	0.1V (REV) 24.0V (STOP) 23.5V (OTHER)	21.7V (REV) 0 (OTHER)	24.0V	0.1V (REV) 24.0V (OTHER)	14.4V (REC) 0 (OTHER)	0.2V (REC) 24.0V (OTHER)
B	0	0	0	0	0.7V (STOP, FF, RWD) 0.3V (OTHER)	0.8V (FWD, REV, REC) 0 (OTHER)	0.1V (REV) 0.7V (OTHER)	0.7V (REV) 0 (OTHER)	0 (REV) 0.8V (STOP) 0.7V (OTHER)	15.7V (REV) 0 (OTHER)	0.8V (REV) 0 (OTHER)	0.1V (REC) 0.7V (OTHER)	0.8V (REC) 0 (OTHER)
TRANSISTOR	TR 15	TR 16	TR 17	TR 18	TR 19	TR 20	TR 21	TR 22	TR 23	TR 24	TR 25	TR 26	TR 27
E											0.2V (FF, RWD) 24.0V (OTHER)	2.1V (FWD, REV, REC) 24.0V (OTHER)	0.6V (FWD, REC) 8.5V (REV) 13.6V (OTHER)
C	13.4V (FF) 0 (OTHER)	0.1V (FF, RWD) 23.7V (OTHER)	24.0V (STOP) 13.4V (RWD) 0 (OTHER)	0.1V (RWD) 23.7V (OTHER)	13.3V (FWD, REC) 0 (OTHER)	0 (FWD, REC) 23.0V (OTHER)	9.1V (REV) 0 (OTHER)	0.2V (REV) 23.7V (OTHER)	13.3V (REC) 0 (OTHER)	0.1V (REC) 24.0V (OTHER)			0.4V (FWD, REC) 8.5V (REV) 0 (OTHER)
B	0.1V (FF) 0.7V (OTHER)	0.8V (FF, RWD) 0 (OTHER)	0.1V (RWD) 0.7V (OTHER)	0.7V (RWD) 0 (OTHER)	0.1V (FWD, REC) 0.7V (OTHER)	0.7V (FWD, REC) 0 (OTHER)	0.1V (REV) 0.7V (OTHER)	0.8V (REV) 0 (OTHER)	0.1V (REC) 0.7V (OTHER)	0.7V (REC) 0 (OTHER)	1.5V (FF, RWD) 24.0V (OTHER)	1.4V (FWD, REV, REC) 23.4V (OTHER)	0.2V (FWD, REC) 7.7V (REV) 24.0V (OTHER)

2. SYS. CON. (B) P.C. BOARD TW-1301

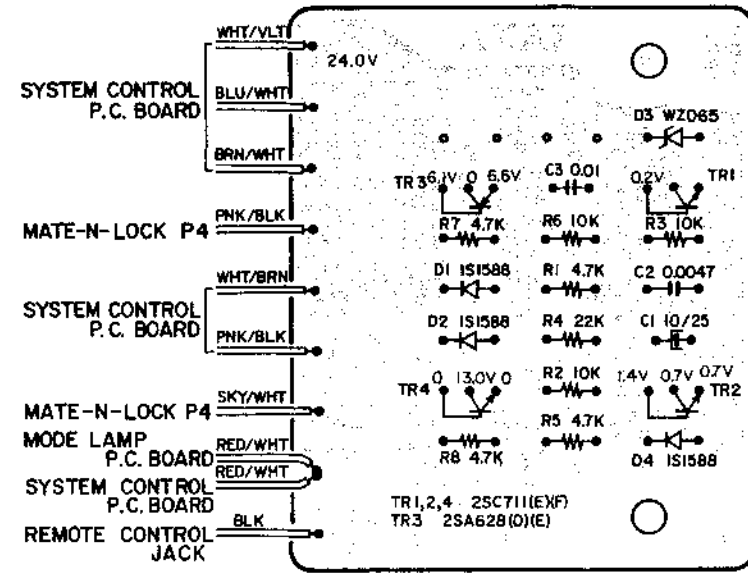

3. POWER SUPPLY P.C. BOARD TW-2018

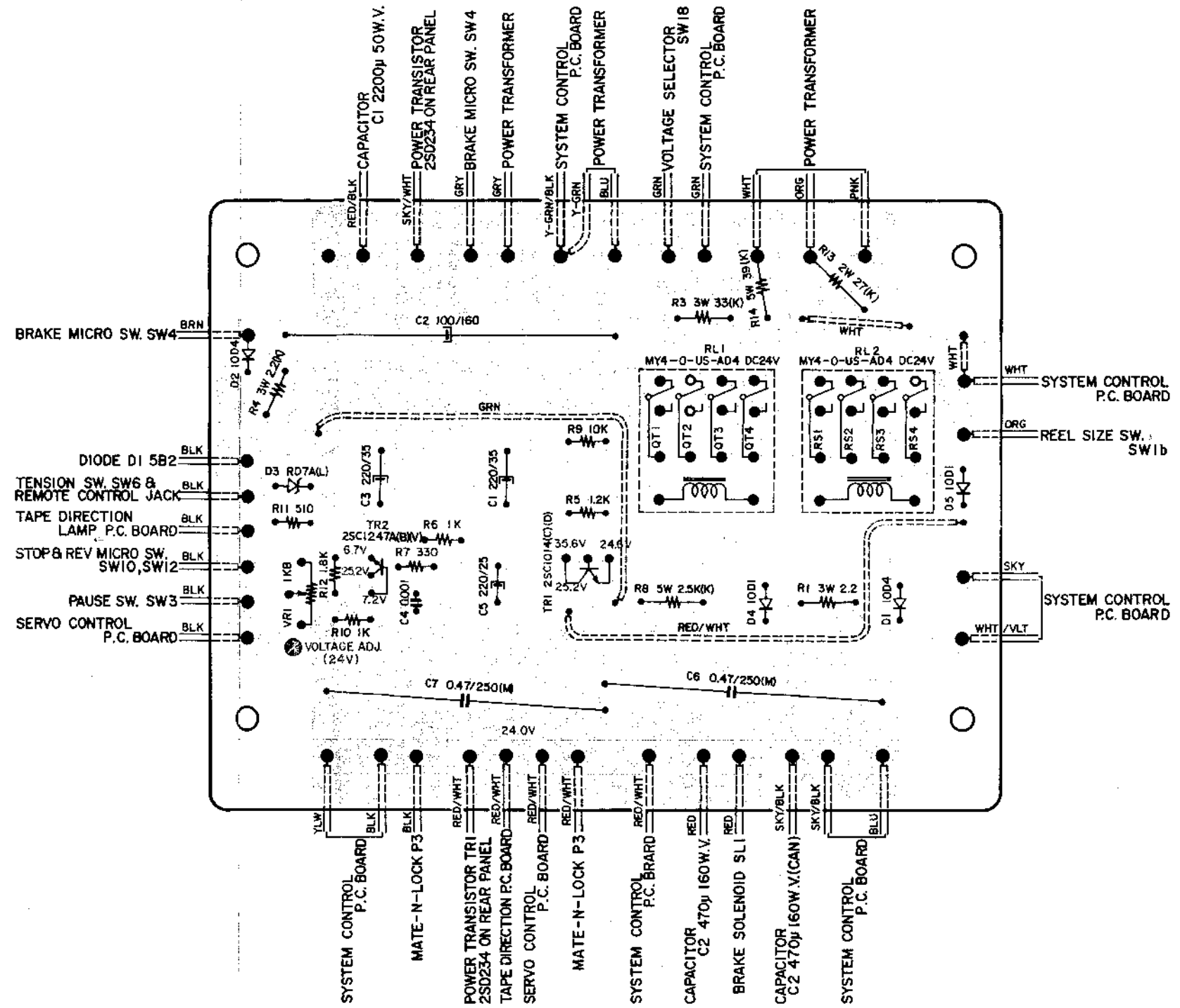

4. SELECTOR P.C. BOARD TW-5311 (REV.)

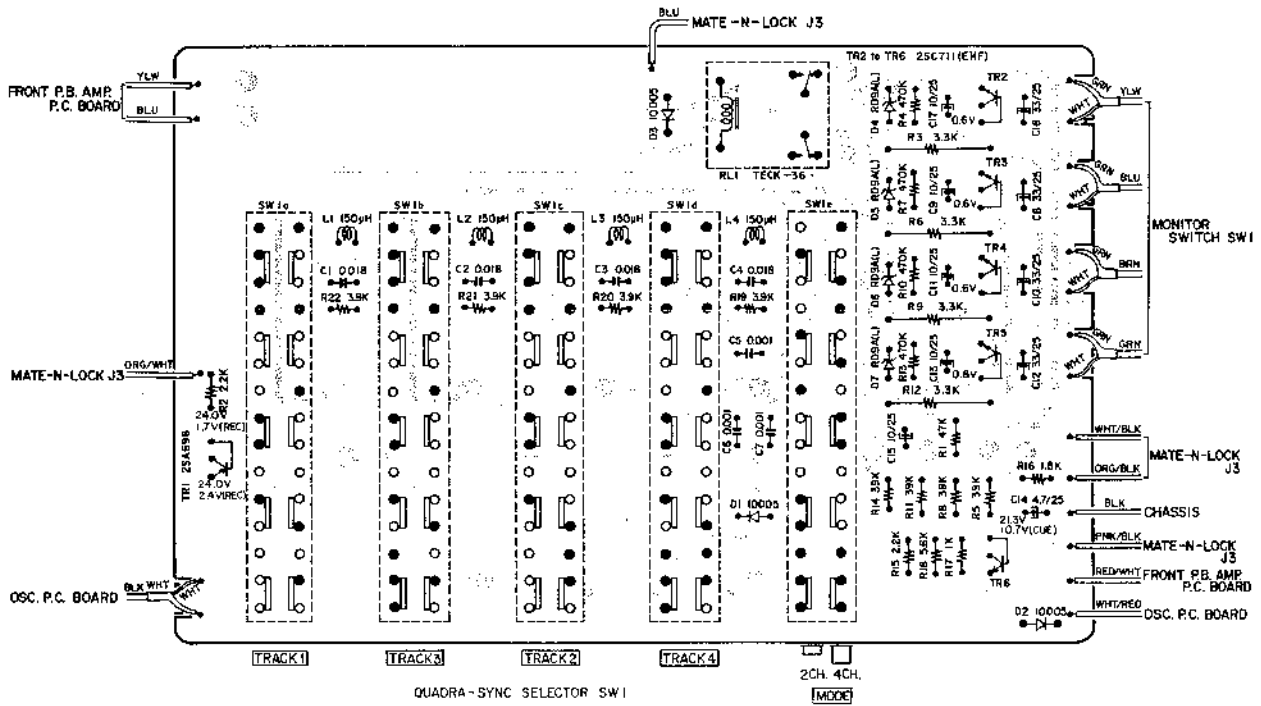

5. SELECTOR P.C. BOARD TW-5311 (FACE)

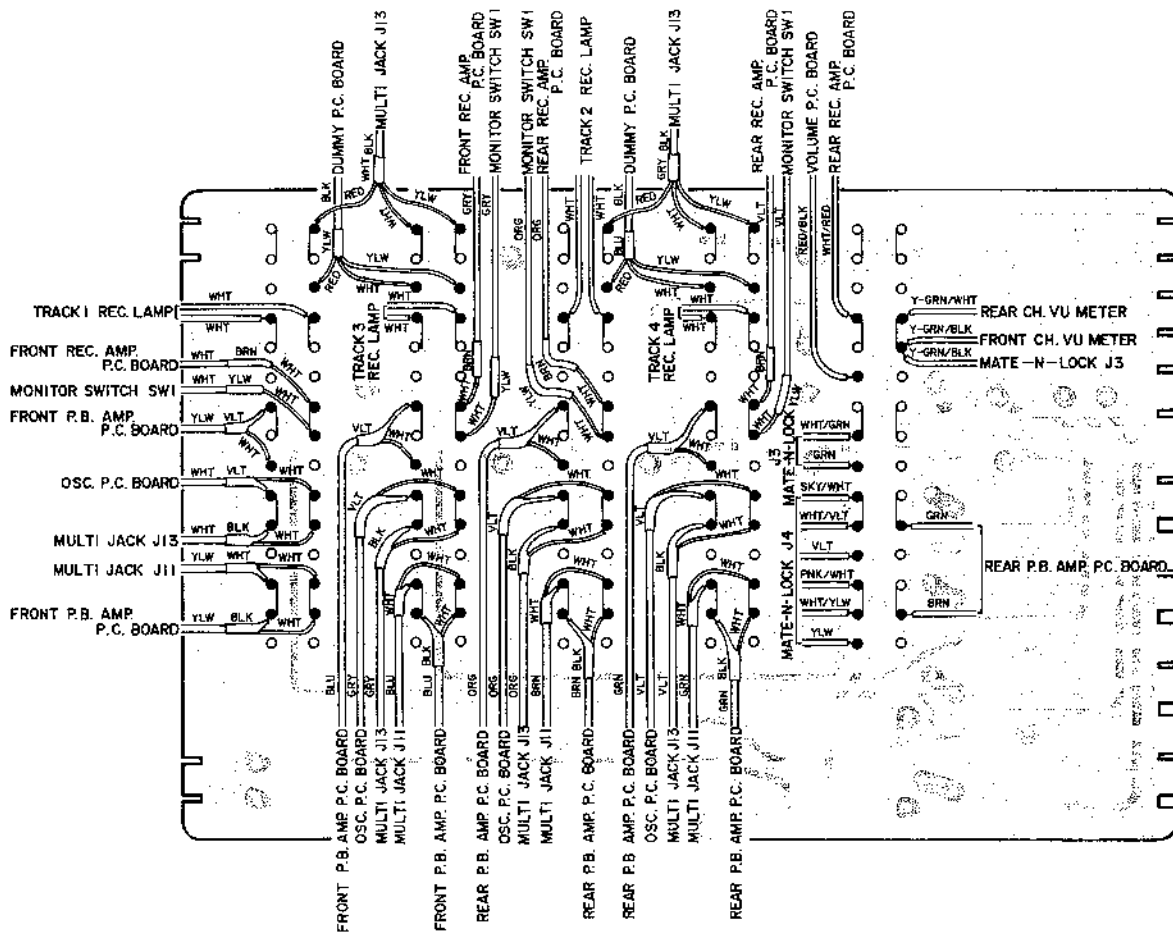

6. TAPE SPEED & EQ. SW. P.C. BOARD TW-5310

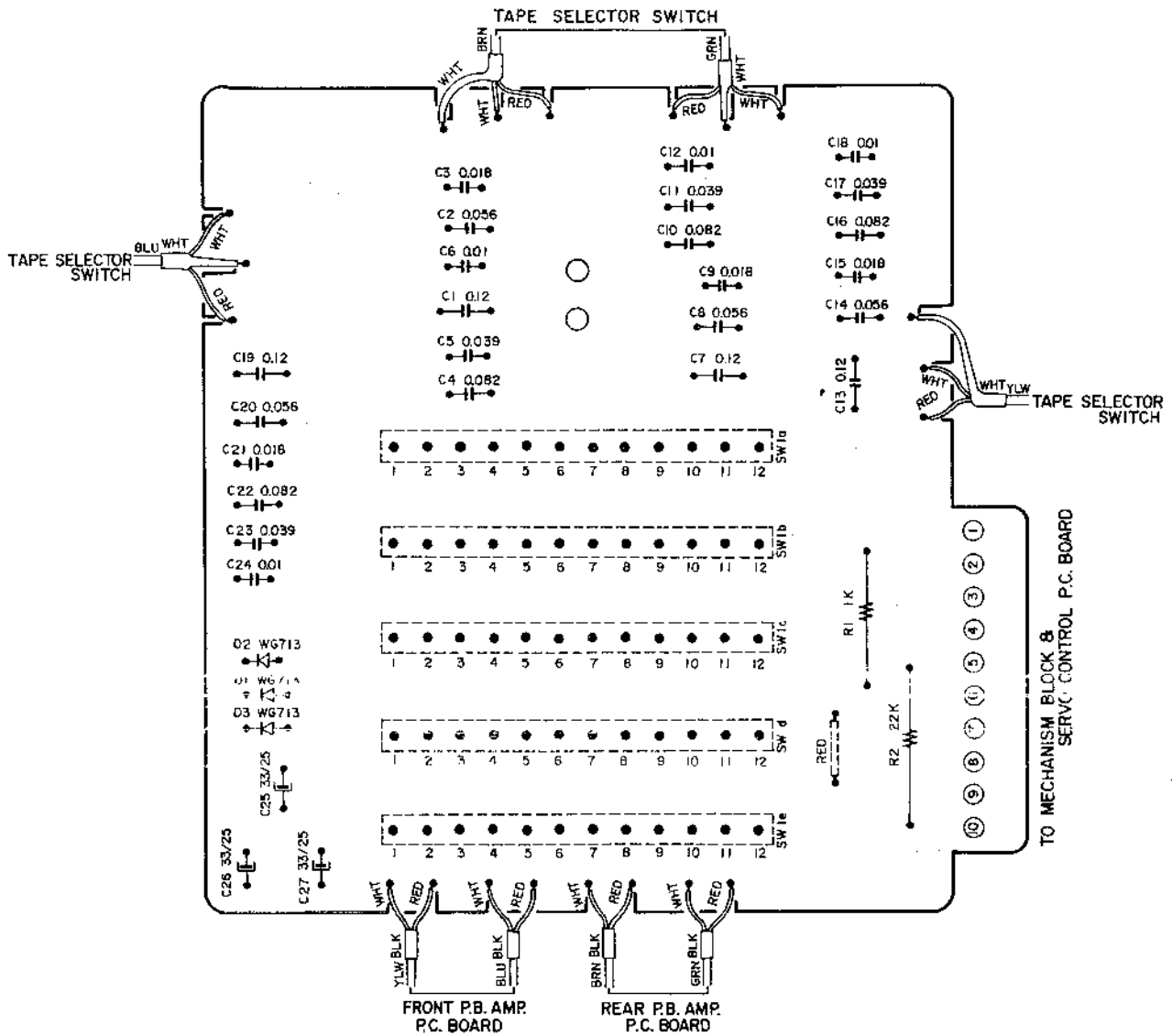

7. VOLUME CONTROL P.C. BOARD TW-5323

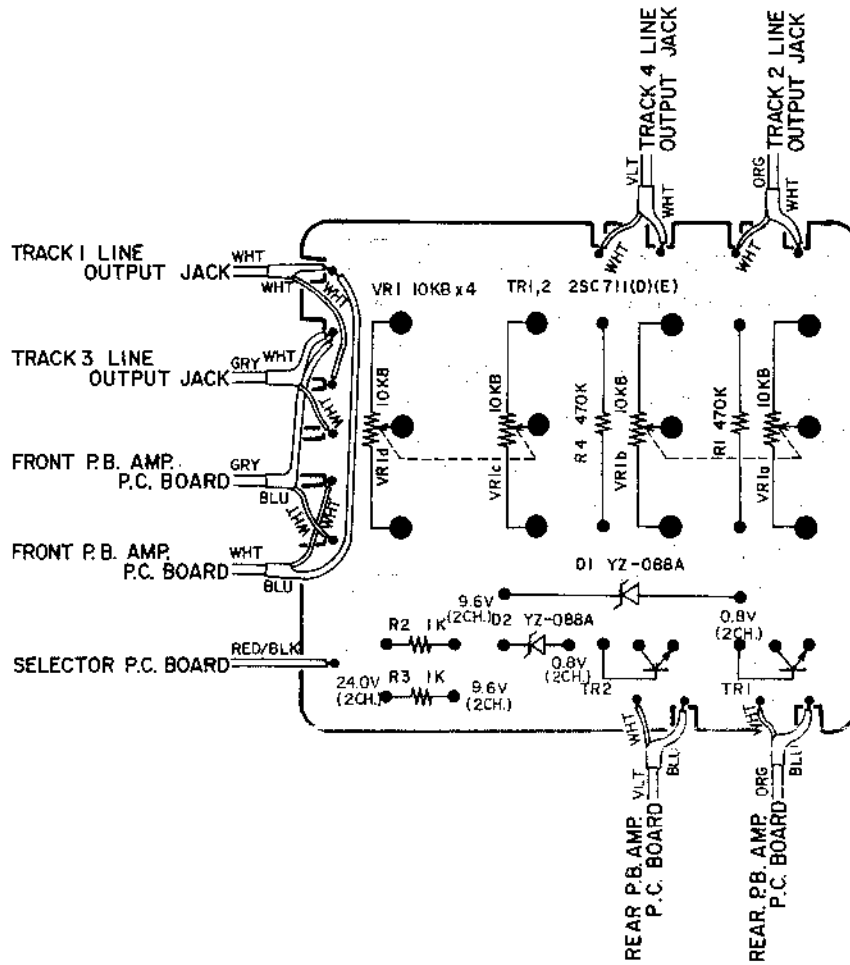

8. DUMMY P.C. BOARD TW-5315

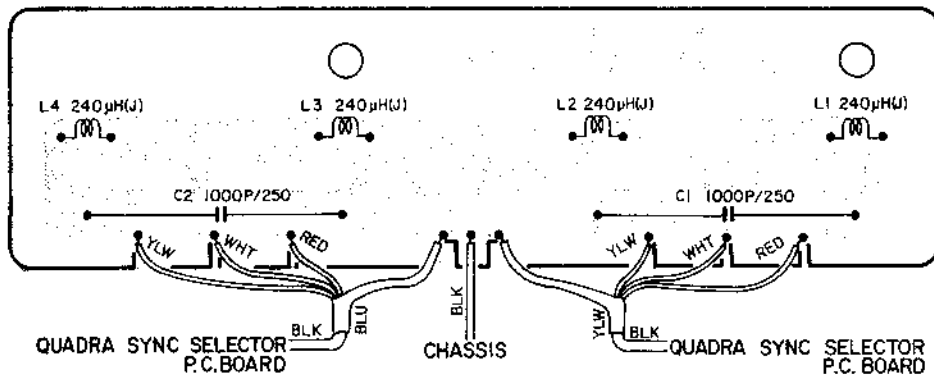

SECTION 2
PARTS LIST

The composite parts of Model GX-400D-SS, except for those which have been changed as per the list below, are identical to those of Model GX-400D. Therefore, when ordering parts for this tape deck, please utilize Model GX-400D Parts List.

TABLE OF CONTENTS

TW HEAD BLOCK	26
POWER SUPPLY BLOCK	26
SYS. CON. P.C. BOARD (TW-1048) BLOCK	26
SYS. CON. (B) P.C. BOARD (TW-1301) BLOCK	26
P.B. AMP. P.C. BOARD (TW-5314) BLOCK	27
REC. AMP. P.C. BOARD (MS-5023) BLOCK	28
OSC. P.C. BOARD (TW-5313) BLOCK	29
EQ. SW. P.C. BOARD (TW-5310) BLOCK	30
SELECTOR P.C. BOARD (TW-5311) BLOCK	31
VOL. P.C. BOARD (TW-5323) BLOCK	32
DUMMY P.C. BOARD (TW-5315) BLOCK	32
HEADPHONE P.C. BOARD (TW-5312) BLOCK	33
AMPLIFIER ASSEMBLY BLOCK	34
FINAL ASSEMBLY BLOCK	34
INDEX	35

HOW TO USE THIS PARTS LIST

1. This parts list is compiled by various individual blocks based on assembly process.
2. When ordering parts, please describe parts number, serial number, and model number in detail.
3. How to read list.

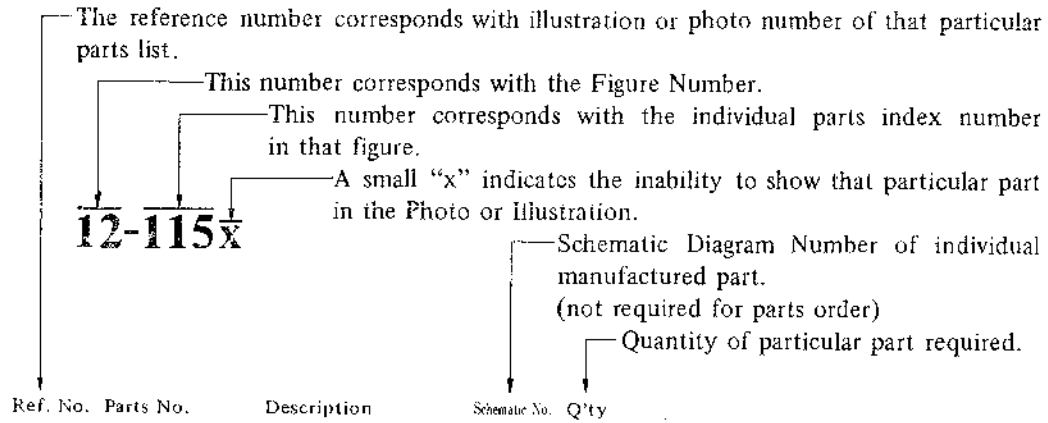

FLYWHEEL BLOCK #13

Ref. No.	Parts No.	Description	Schematic No.	Q'ty
12-115x	800425	Flywheel Block Assy. Comp.	RDG #13	1
12-116	244506	Flywheel Only	RD-233	1
12-117x	244754	Felt, Flywheel	RD-275	1
12-118	251324	Main Metal Case	RD-236	1
12-119	253080	Main Metal	RD-237	1

4. The symbol numbers shown on the P.C. Board list can be matched with the Composite Views of components of the Schematic Diagram or Service manual.
5. The indications of Resistors and Capacitors in the photos of P.C. Board are being eliminated.
6. The shape of the parts and parts name, etc. can be confirmed by comparing them with the parts shown on the Electrical Parts Table of P.C. Board.
7. Both the kind of part and installation position can be determined by the Parts Number. To determine where a parts number is listed, utilize Parts Index at end of Parts List.
It is necessary first of all to find the Parts Number. This can be accomplished by using the Reference Number listed at right of parts number in the Parts Index. (meaning of ref. no. outlined in Item 3 above).
8. Utilize separate "Price List for Parts" to determine unit price. The most simple method of finding parts Price is to utilize the reference number.

ELECTRICAL PARTS TABLE

<p>Because the indication of resistors and capacitors in the P. C. Board photos are being eliminated, please confirm parts name and shape by comparing them with the parts shown in this table.</p>	<p style="text-align: center;">1</p>  <p style="text-align: center;">Solid Resistor</p>	<p style="text-align: center;">2</p> <p style="text-align: right;">Stopper Type</p>  <p style="text-align: center;">Insulator Type</p> <p style="text-align: center;">Carbon Resistor</p>	<p style="text-align: center;">3</p>  <p style="text-align: center;">Metal Oxide Film Resistor</p>
<p style="text-align: center;">4</p>  <p style="text-align: center;">Cement Resistor</p>	<p style="text-align: center;">5</p>  <p style="text-align: center;">Wire-Wound Resistor</p>	<p style="text-align: center;">6</p>  <p style="text-align: center;">Thermister</p>	<p style="text-align: center;">7</p>  <p style="text-align: center;">Enamel Resistor</p>
<p style="text-align: center;">1</p>  <p style="text-align: center;">MP Capacitor (Tubular Type)</p>	<p style="text-align: center;">2</p>  <p style="text-align: center;">Plastic Capacitor</p>	<p style="text-align: center;">3</p>  <p style="text-align: center;">Mylar Capacitor</p>	<p style="text-align: center;">4</p>  <p style="text-align: center;">VFM (Hi-Q) Capacitor</p>
<p style="text-align: center;">5</p>  <p style="text-align: center;">Mylar Capacitor</p>	<p style="text-align: center;">6</p>  <p style="text-align: center;">Tantalum Capacitor</p>	<p style="text-align: center;">7</p>  <p style="text-align: center;">Oil Capacitor (Tubular Type)</p>	<p style="text-align: center;">8</p> <p style="text-align: right;">Vertical Type</p> <p style="text-align: center;">(Tubular Type)</p>  <p style="text-align: center;">Styrol Capacitor</p>
<p style="text-align: center;">9</p>  <p style="text-align: center;">Electrolytic Capacitor (Tubular Type)</p>	<p style="text-align: center;">10</p> <p style="text-align: right;">Vertical Type</p> <p style="text-align: center;">(Tubular Type)</p>  <p style="text-align: center;">Electrolytic Capacitor</p>	<p style="text-align: center;">11</p>  <p style="text-align: center;">Ceramic Capacitor</p>	<p style="text-align: center;">12</p>  <p style="text-align: center;">Metalized Mylar (Paper) Capacitor</p>
<p style="text-align: center;">13</p>  <p style="text-align: center;">Trimmer Condenser</p>		<p style="text-align: center;">VR</p>  <p style="text-align: center;">Semi-Fixed Volume</p>	
<p style="text-align: center;">L</p>  <p style="text-align: center;">Ferri Inductor</p>	<p style="text-align: center;">TR</p>  <p style="text-align: center;">Transistor</p>		
<p style="text-align: center;">CR</p>  <p style="text-align: center;">Spark Quencher</p>	<p style="text-align: center;">D</p>  <p style="text-align: center;">Diode (Silicon, Zener, Germanium)</p>		

TW HEAD BLOCK

Ref. No.	Parts No.	Description	Schematic No.	Q'ty
1-1x	BH565664	TW-3 Head Block Comp.	TW-3	1
1-17x	HP513281	PB. HEAD P4-280		1
1-18x	HR565672	REC. HEAD BLOCK		
		R4-285		1
1-19x	HE563220	ERASE HEAD BLOCK		
		E4-260		2
1-21x	HA549944	REH Angle	TW-0301	1
1-34x	EA441685	Terminal P.C. Board,		
		18P	KF-1003	1

POWER SUPPLY BLOCK

8-1x	BP565683	Power Supply Block		
		Comp.	TW-3	1
8-2x	BP565694	Power Supply Block		
		Comp. (3 core)	TW-3	1

SYS. CON. P.C. BOARD (TW-1048) BLOCK

10-1x	BA565705	Sys. Con. P.C. Board		
		Comp. (TW-1048)		1
10-TR11	ET453486	Transistor 2SC711(E)(F)		1
10-D64,65,66	ED557447	Silicon Diode IS1588		3

PHOTO OF SYS. CON. (B) P.C. BOARD
(TW-1301) BLOCK

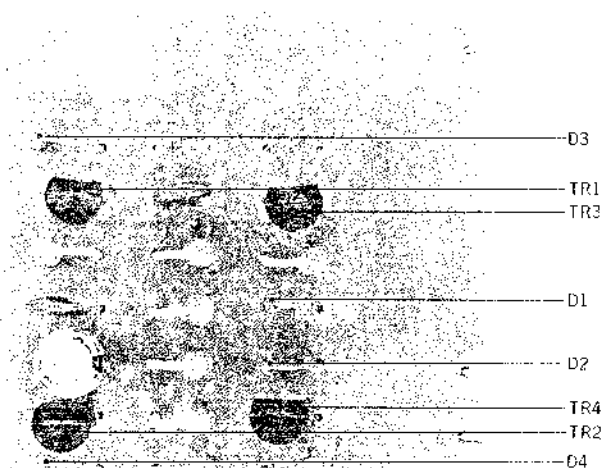

SYS. CON. (B) P.C. BOARD (TW-1301) BLOCK

Symbol No.	Parts No.	Description	Q'ty
11-1x	BA565716	Sys. Con. (B) P.C. Board Comp. (TW-1301)	1
11-TR1,2	ET453486	Transistor 2SC711(E)(F)	2
11-TR3	ET538110	Transistor 2SA628(D)(E)	1
11-TR4	ET453486	Transistor 2SC711(E)(F)	1
11-D3	ED555895	Zener Diode WZ-065	1
11-D4	ED557447	Silicon Diode IS1588	1
		Capacitor, Vertical Type	
11-C1	EC220994	Elect. 10 μ F 25WV	1
11-C2	EC362158	Mylar 0.0047 μ F(K) 50WV	1
11-C3	EC250885	Mylar 0.01 μ F(K) 50WV	1
		Resistor, Stopper Type	
11-R1	ER212883	Carbon RD1/4 4.7k(J)	1
11-R2, 3	ER336442	Carbon RD1/4 10k(J)	2
11-R4	ER212264	Carbon RD1/4 22k(J)	1
11-R5	ER212883	Carbon RD1/4 4.7k(J)	1
11-R6	ER336442	Carbon RD1/4 10k(J)	1
11-R7, 8	ER212883	Carbon RD1/4 4.7k(J)	2

PHOTO OF P.B. AMP. P.C. BOARD (TW-5314) BLOCK

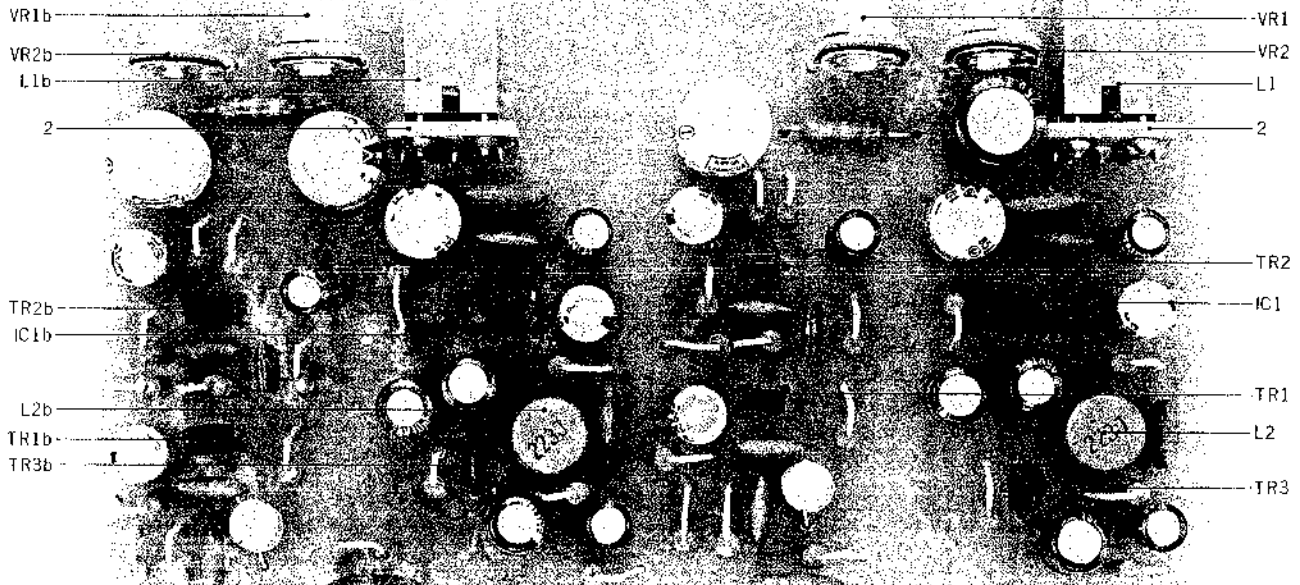

PB. AMP. P.C. BOARD (TW-5314) BLOCK

Symbol No.	Parts No.	Description	Q'ty	Symbol No.	Parts No.	Description	Q'ty
12-1x	BA565740	PB. Amp. P.C. Board Comp. (TW-5314)	1			Resistor, Stopper Type	
12-TR1, 2	ET234854	Transistor 2SC458LG(C)	4	12-R1	ER346601	Carbon RD1/4 47k(J)	2
12-TR3	ET398711	Transistor 2SC945(Q)(R)	2	12-R2	ER336442	Carbon RD1/4 10k(J)	2
12-IC1	EI412413	I.C. Line Amp. LD-3141	2	12-R3	ER212681	Carbon RD1/4 330(J)	3
12-L1	EO346230	Inductor RX22MH	2	12-R4	ER362485	Carbon RD1/4 330k(J)	2
12-L2	EO244012	Ferri Inductor FL9H 22MH(J)	2	12-R5	ER426857	Carbon RD1/4 270k(J)	2
12-VR1	EV497711	Semi-fixed/Vol. V10K8-1-5 500ΩB(4US)	2	12-R6	ER212872	Carbon RD1/4 4.3k(J)	2
12-VR2	EV497698	Semi-fixed/Vol. V10K8-1-5 20 kΩ(4US)	2	12-R7	ER212883	Carbon RD1/4 4.7k(J)	2
12-2	EA496258	Inductor P.C. Board	2	12-R8	ER357456	Carbon RD1/4 2.2k(J)	2
		Capacitor, Vertical Type		12-R9	ER212477	Carbon RD1/4 3.3k(J)	2
12-C1	EC290520	VFM 100PF(J) 50WV	2	12-R10	ER357570	Carbon RD1/4 150k(J)	2
12-C2	EC432810	Elect. 10μF 16WV NL	2	12-R11	ER212883	Carbon RD1/4 4.7k(J)	2
12-C3	EC290520	VFM 100PF(J) 50WV	2	12-R12	ER345712	Carbon RD1/4 22k(J)	2
12-C4	EC329771	Elect. 47μF 6.3WV	2	12-R13	ER336442	Carbon RD1/4 10k(J)	2
12-C5	EC250841	Mylar 0.01μF(J) 50WV	2	12-R14	ER306360	Carbon RD1/4 6.8k(J)	2
12-C6	EC336216	VFM 330PF(J) 50WV	2	12-R15	ER212264	Carbon RD1/4 22k (J)	2
12-C7	EC290520	VFM 100PF(J) 50WV	2	12-R16	ER429996	Carbon RD1/4 470k(J)	2
12-C8	EC450055	Elect. 1μF 25WV	2	12-R17	ER212264	Carbon RD1/4 22k(J)	2
12-C9	EC329771	Elect. 47μF 6.3WV	2				
12-C10	EC476965	Elect. 47μF 25WV NL	2				
12-C11	EC336126	Elect. 47μF 25WV	2				
12-C12	EC329850	VFM 220PF(J) 50WV	2				
12-C13	EC290520	VFM 100PF(J) 50WV	2				
12-C14	EC320051	Elect. 10μF 16WV	2				
12-C15	EC329771	Elect. 47μF 6.3WV	2				
12-C16	EC336104	Elect. 100 μF 6.3WV	2				
12-C17	EC220994	Elect. 10μF 25WV	2				
12-C18	EC450055	Elect. 1μF 25WV	2				
12-C19,20	EC220994	Elect. 10μF 25WV	4				
12-C21	EC310792	VFM 120PF(J) 50WV	2				

PHOTO OF REC. AMP. P.C. BOARD (MS-5023) BLOCK

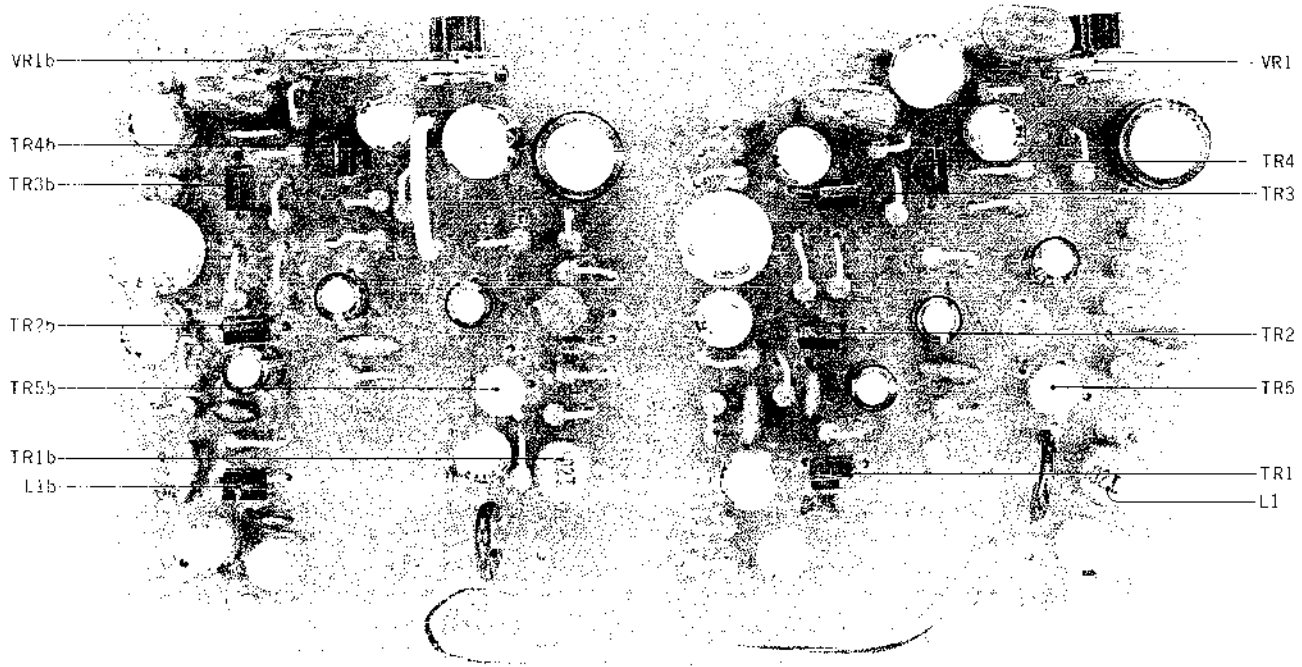

REC. AMP. P.C. BOARD (MS-5023) BLOCK

Symbol No.	Parts No.	Description	Q'ty	Symbol No.	Parts No.	Description	Q'ty
13-1x	BA565806	Rec. Amp. P.C. Board Comp. (MS-5023)	1	13-R1, 2	ER336442	Resistor, Stopper Type Carbon RD1/4 10k(J)	4
13-TR1, 2,3	ET234854	Transistor 2SC458LG(C)	6	13-R3	ER362485	Carbon RD1/4 330k(J)	2
13-TR4	ET453486	Transistor 2SC711(E)(F)	2	13-R4	ER213300	Carbon RD1/4 680(J)	2
13-TR5	ET446736	Transistor 2SC968(2)(3)	2	13-R5	ER357570	Carbon RD1/4 150k(J)	2
13-L1	EO243977	Ferri Inductor FL7H 1MH(J)	2	13-R6	ER212264	Carbon RD1/4 22k(J)	2
13-VR1	EV398812	Semi-fixed/Vol. V10K5 5 kB w/knob	2	13-R7	ER346994	Carbon RD1/4 18k(J)	2
		Capacitor, Vertical Type		13-R8	ER343078	Carbon RD1/4 2.7k(J)	2
13-C1	EC432810	Elect. 10μF 16WV NL	2	13-R9	ER211320	Carbon RD1/4 1.5k(J)	2
13-C2	EC383501	Mylar 0.001μF(M) 50WV	2	13-R10	ER357456	Carbon RD1/4 2.2k(J)	2
13-C3	EC329771	Elect. 47μF 6.3WV	2	13-R11	ER212883	Carbon RD1/4 4.7k(J)	2
13-C4	EC399690	VFM 33PF(J) 50WV	2	13-R12	ER349942	Carbon RD1/4 8.2k(J)	2
13-C5	EC290531	VFM 100PF(K) 50WV	2	13-R13	ER211757	Carbon RD1/4 100k(J)	2
13-C6	EC320051	Elect. 10μF 16WV	2	13-R14	ER357412	Carbon RD1/4 220(J)	2
13-C7	EC329771	Elect. 47μF 6.3WV	2	13-R15	ER211757	Carbon RD1/4 100k(J)	2
13-C8	EC476965	Elect. 47μF 25WV NL	2	13-R16	ER349907	Carbon RD1/4 33k(J)	2
13-C9	EC336126	Elect. 47μF 25WV	2	13-R17	ER357456	Carbon RD1/4 2.2k(J)	2
13-C10	EC320051	Elect. 10μF 16WV	2	13-R18	ER212681	Carbon RD1/4 330(J)	2
13-C11	EC290531	VFM 100PF(K) 50WV	2	13-R19	ER349784	Carbon RD1/4 390(J)	2
13-C12	EC329771	Elect. 47μF 6.3WV	2	13-R20	ER350100	Carbon RD1/4 68k(J)	2
13-C13	EC220994	Elect. 10μF 25WV	2	13-R21	ER212681	Carbon RD1/4 330(J)	2
13-C14	EC336104	Elect. 100μF 6.3WV	2	13-R22	ER336442	Carbon RD1/4 10k(J)	2
13-C15	EC368370	Mylar 0.15μF(J) 50WV	2	13-R23	ER343078	Carbon RD1/4 2.7k(J)	2
13-C16	EC333562	Mylar 0.18μF(K) 50WV	2	13-R24	ER346994	Carbon RD1/4 18k(J)	2
13-C17	EC320051	Elect. 10μF 16WV	2	13-R25	ER352045	Carbon RD1/4 3.9k(J)	2
13-C18	EC423033	VFM 680PF(K) 50WV	2	13-R26	ER211465	Carbon RD1/4 1k(J)	2
13-C19	EC220994	Elect. 10μF 25WV	2	13-R27	ER349784	Carbon RD1/4 390(J)	2
13-C20	EC250841	Mylar 0.01μF(J) 50WV	2	13-R28	ER336442	Carbon RD1/4 10k(J)	2
				13-R29	ER212264	Carbon RD1/4 22k(J)	2
				13-R30	ER349784	Carbon RD1/4 390(J)	2

When ordering parts, please describe Parts Number, Serial Number, and Model Number in detail.

PHOTO OF OSC. P.C. BOARD (TW-5313) BLOCK

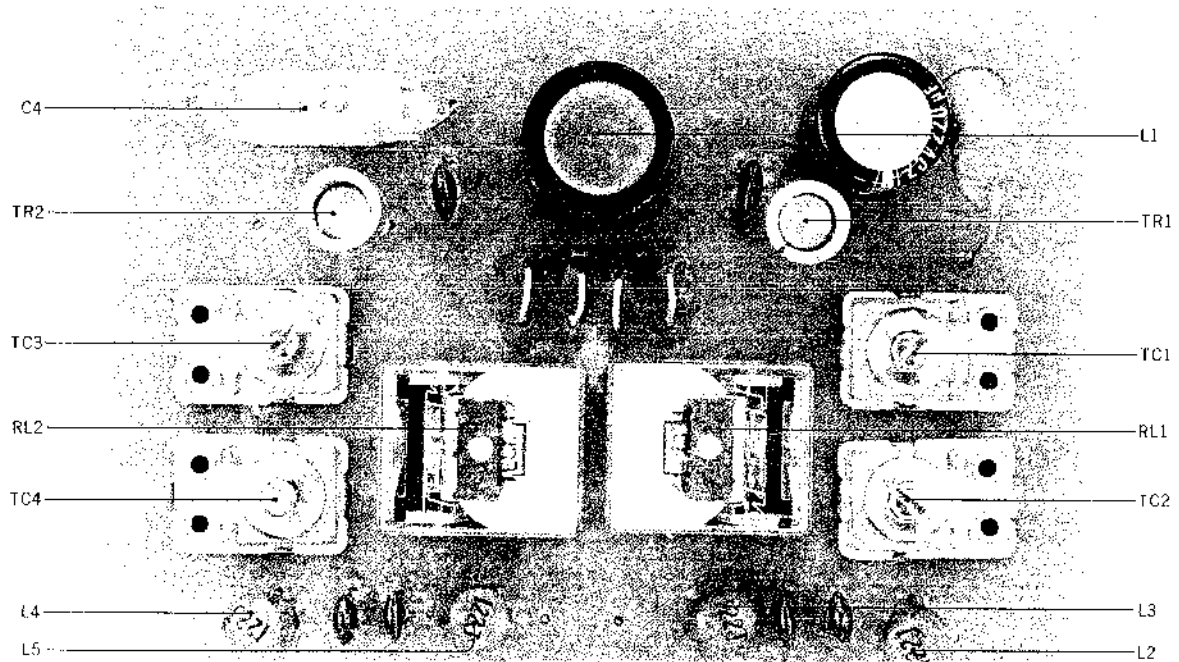

OSC. P.C. BOARD (TW-5313) BLOCK

Symbol No.	Parts No.	Description	Q'ty
14-1x	BA565738	Osc. P.C. Board Comp. (TW-5313)	1
14-TR1 to 3	ET520288	Transistor 2SC1247A(V)	3
14-D1 to 3	ED515790	Silicon Diode WG-713	3
14-L1	EO383365	Osc. Coil OT-204	1
14-L2 to 5	EO424866	Ferri Inductor FL7H 1.2 MH(J)	4
14-RL1, 2	EP315461	Relay TECK-19 1500Ω	2
14-TC1 to 4	EC425250	Trimmer/C. A-1P3-3 70 PF	4
Capacitor, Vertical Type			
14-C1, 2	EC250841	Mylar 0.01μF(J) 50WV	2
14-C3	EC220678	Elect. 47μF 25WV	1
14-C4	EC346522	Plastic Film 2200PF(J) 500WV	1
14-C5 to 8	EC379765	Mylar 0.0027μF(J) 50WV	4
14-C9	EC350684	Elect. 22μF 25WV	1
14-C10, 11	EC336126	Elect. 47μF 25WV	2
14-C12, 13	EC220151	Elect. 100μF 25WV	2
Resistor, Stopper Type			
14-R1, 2	ER315944	Carbon RD1/4 3.3(J)	2
14-R3	ER427972	Metal Oxide Film 2W 68Ω(K)	1
14-R4	ER304378	Carbon RD1/4 470(J)	1
14-R5	ER211465	Carbon RD1/4 1k(J)	1
14-R6	ER211320	Carbon RD1/4 1.5k(J)	1
14-R7	ER364972	Carbon RD1/4 1.5k(J)	1
14-R8	ER357456	Carbon RD1/4 2.2k(J)	1
14-R9	ER336442	Carbon RD1/4 10k(J)	1

PHOTO OF EQ. SW. P.C. BOARD
(TW-5310) BLOCK

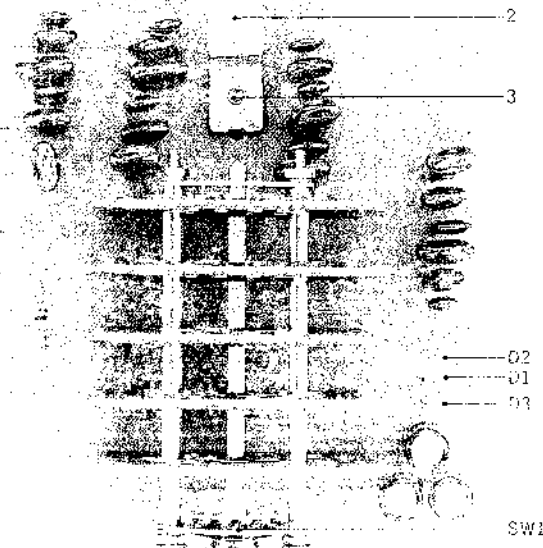

EQ. SW. P.C. BOARD (TW-5310) BLOCK

Symbol No.	Parts No.	Description	Q'ty
18-1x	BA565762	EQ. SW. P.C. Board Comp. (TW-5310)	1
18-D1 to 3	ED515790	Silicon Diode WG-713	3
18-SW1	ES591603	Rotary SW. SRE-5183	1
18-2	EZ534172	T. Type Angle	1
18-3	ZS325495	Tapping Screw #2 3x6 (BR)	1
Capacitor, Vertical Type			
18-C1	EC399734	Mylar 0.12 μ F(J) 50WV	1
18-C2	EC368357	Mylar 0.056 μ F(J) 50WV	1
18-C3	EC389485	Mylar 0.018 μ F(J) 50WV	1
18-C4	EC438041	Mylar 0.082 μ F(J) 50WV	1
18-C5	EC379192	Mylar 0.039 μ F(J) 50WV	1
18-C6	EC250841	Mylar 0.01 μ F(J) 50WV	1
18-C7	EC399734	Mylar 0.12 μ F(J) 50WV	1
18-C8	EC368357	Mylar 0.056 μ F(J) 50WV	1
18-C9	EC389485	Mylar 0.018 μ F(J) 50WV	1
18-C10	EC438041	Mylar 0.082 μ F(J) 50WV	1
18-C11	EC379192	Mylar 0.039 μ F(J) 50WV	1
18-C12	EC250841	Mylar 0.01 μ F(J) 50WV	1
18-C13	EC399734	Mylar 0.12 μ F(J) 50WV	1
18-C14	EC368357	Mylar 0.056 μ F(J) 50WV	1
18-C15	EC389485	Mylar 0.018 μ F(J) 50WV	1
18-C16	EC438041	Mylar 0.082 μ F(J) 50WV	1
18-C17	EC379192	Mylar 0.039 μ F(J) 50WV	1
18-C18	EC250841	Mylar 0.01 μ F(J) 50WV	1
18-C19	EC399734	Mylar 0.12 μ F(J) 50WV	1
18-C20	EC368357	Mylar 0.056 μ F(J) 50WV	1
18-C21	EC389485	Mylar 0.018 μ F(J) 50WV	1
18-C22	EC438041	Mylar 0.082 μ F(J) 50WV	1
18-C23	EC379192	Mylar 0.039 μ F(J) 50WV	1
18-C24	EC250841	Mylar 0.01 μ F(J) 50WV	1
18-C25to27	EC456041	Elect. 33 μ F 25WV	3
Resistor, Insulator Type			
18-R1	ER324641	Carbon RD1/4 1k(J)	1
18-R2	ER345712	Carbon RD1/4 22k(J)	1

PHOTO OF SELECTOR P.C. BOARD (TW-5311) BLOCK

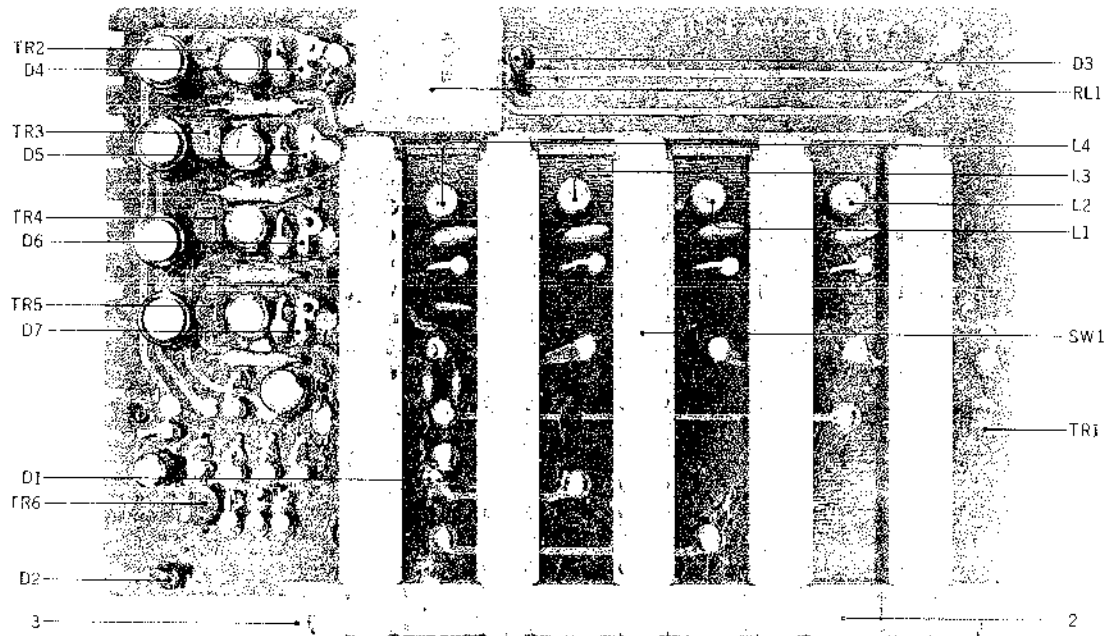

SELECTOR P.C. BOARD (TW-5311) BLOCK

Symbol No.	Parts No.	Description	Q'ty	Symbol No.	Parts No.	Description	Q'ty
19-1x	BA565773	Selector P.C. Board Comp. (TW-5311)	1				
						Resistor, Stopper Type	
19-TR1	ET515880	Transistor 2SA696(C)(D)	1	19-R1	ER346601	Carbon RD1/4 47k(J)	1
19-TR2 to 6	ET453486	Transistor 2SC711(E)(F)	5	19-R2	ER357456	Carbon RD1/4 2.2k(J)	1
19-D1 to 3	ED494583	Silicon Diode 10D05	3	19-R3	ER364948	Carbon RD1/4 3.3k(J)	1
19-D4 to 7	ED520762	Zener Diode YZ-088A	4	19-R4	ER429996	Carbon RD1/4 470k(J)	1
19-L1 to 4	EO575482	Ferri Inductor FL7H 150μH(J)	4	19-R5	ER357535	Carbon RD1/4 39k(J)	1
19-SW1	ES565536	Push SW. 5FST-50U-773-3	1	19-R6	ER364948	Carbon RD1/4 3.3k(J)	1
19-RL1	EP383321	Relay TECK-36 DC22V 1000Ω	1	19-R7	ER429996	Carbon RD1/4 470k(J)	1
19-2	EZ549977	SW. Base A	1	19-R8	ER357535	Carbon RD1/4 39k(J)	1
19-3	ZS323728	ISO Screw, binding head 3x5	2	19-R9	ER364948	Carbon RD1/4 3.3k(J)	1
				19-R10	ER429996	Carbon RD1/4 470k(J)	1
		Capacitor, Vertical Type		19-R11	ER357535	Carbon RD1/4 39k(J)	1
19-C1 to 4	EC302297	Mylar 0.018μF(K) 50WV	4	19-R12	ER364948	Carbon RD1/4 3.3k(J)	1
19-C5 to 7	EC250604	Mylar 0.001μF(K) 50WV	3	19-R13	ER429996	Carbon RD1/4 470k(J)	1
19-C8	EC220612	Elect. 33μF 25WV	1	19-R14	ER357535	Carbon RD1/4 39k(J)	1
19-C9	EC220994	Elect. 10μF 25WV	1	19-R15	ER357456	Carbon RD1/4 2.2k(J)	1
19-C10	EC220612	Elect. 33μF 25WV	1	19-R16	ER362441	Carbon RD1/4 1.8k(J)	1
19-C11	EC220994	Elect. 10μF 25WV	1	19-R17	ER211465	Carbon RD1/4 1k(J)	1
19-C12	EC220612	Elect. 33μF 25WV	1	19-R18	ER213030	Carbon RD1/4 5.6k(J)	1
19-C13	EC220994	Elect. 10μF 25WV	1	19-R19 to 22	ER352045	Carbon RD1/4 3.9k(J)	4
19-C14	EC450527	Elect. 4.7μF 25WV	1				
19-C15	EC220994	Elect. 10μF 25WV	1				
19-C16	EC220612	Elect. 33μF 25WV	1				
19-C17	EC220994	Elect. 10μF 25WV	1				

**PHOTO OF VOL. P.C. BOARD
(TW-5323) BLOCK**

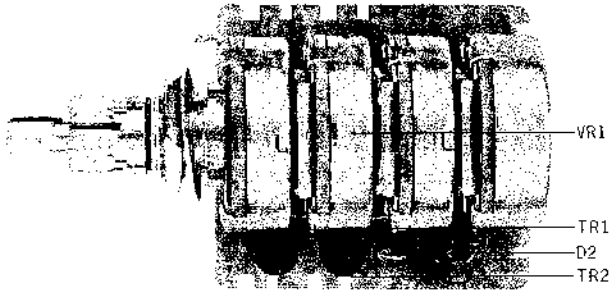

VOL. P.C. BOARD (TW-5323) BLOCK

Symbol No.	Parts No.	Description	Q'ty
21-1x	BA570543	Vol. P.C. Board Comp. (TW-5323)	1
21-TR1, 2	ET453486	Transistor 2SC711 (E)(F)	2
21-D1, 2	ED520762	Zener Diode YZ-088A	2
21-VR1	EV570554	Double/Vol. KJ-60R, 10 kBx4	1
Resistor, Insulator Type			
21-R1	ER443790	Carbon RD1/4 470k(J)	1
21-R2, 3	ER211465	Carbon RD1/4 1k(J)	2
21-R4	ER443790	Carbon RD1/4 470k(J)	1

PHOTO OF DUMMY P.C. BOARD (TW-5315) BLOCK

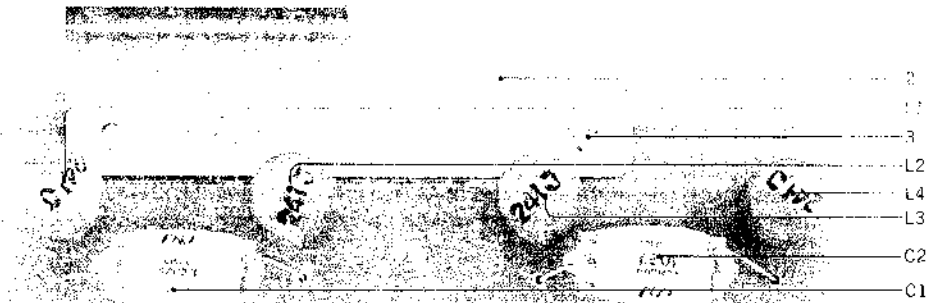

DUMMY P.C. BOARD (TW-5315) BLOCK

Symbol No.	Parts No.	Description	Q'ty
22-1x	BA565784	Dummy P.C. Board Comp. (TW-5315)	1
22-L1 to 4	EO565558	Ferri Inductor FL9H 240μH(J)	4
22-2	EZ549808	Dummy P.C. Board Angle	1
22-3	ZS323728	Screw, binding head 3x5	2
22-C1, 2	EC565560	Plastic Film/C. 1000PF (J) 250WV	2

PHOTO OF HEADPHONE P.C. BOARD (TW-5312) BLOCK

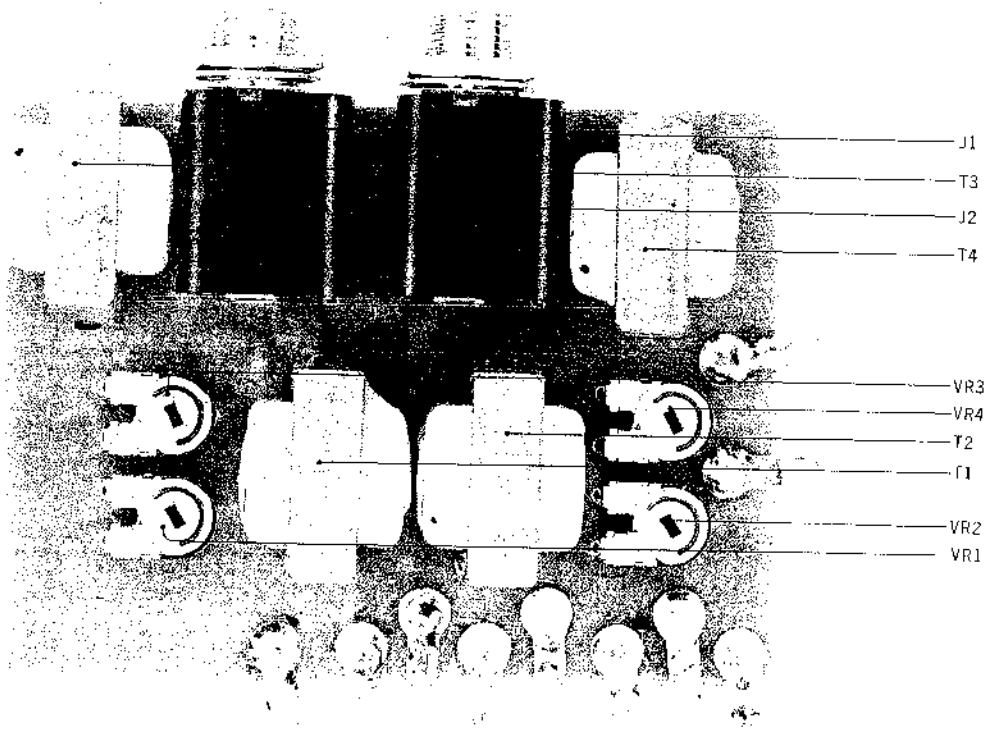

HEADPHONE P.C. BOARD (TW-5312) BLOCK

Symbol No.	Parts No.	Description	Q'ty
23-1x	BA565795	Headphone P.C. Board Comp.	1
23-T1 to 4	BT247768	Headphone Trans. N19-5921S	4
23-VR1 to 4	EV464207	Semi-fixed/Vol. V8K4-1 5 dB	2
23-J1, 2	EJ437321	Jack, 3P Molded 3PMJ1P	2

AMPLIFIER ASSEMBLY BLOCK

FINAL ASSEMBLY BLOCK

Ref. No.	Parts No.	Description	Schematic No.	Q'ty	Ref. No.	Parts No.	Description	Schematic No.	Q'ty
24-1x	BZ565751	Jack Plate Block Comp.	TW-3	1	25-1x	SP565637	Mech. Panel Block Comp.	TW-3	1
24-5x	ER213873	Carbon/R. RD1/4 150k(J) (Insu. type)	35-9-5	4	25-21x	SM549742	Name Plate TW-3	TW-6303	1
24-6x	ER345756	Carbon/R. RD1/4 68k(J) (Insu. type)	35-9-5	4	25-23x	SM549753	Symble Mark TW-3	TW-6302	1
24-7x	ER214536	Carbon/R. RD1/4 6.8k(J)	35-9-5	4	25-51x	SP566177	Control Panel 3	TW-6015	1
24-8x	ER430288	Carbon/R. RD1/4 680(J)	35-9-5	4	25-66x	SK549933	Selector Knob E	TW-6310	2
24-9x	ER213647	Carbon/R. RD1/4 10k(J)	35-9-5	4	25-77x	SP578891	Amp. Panel E	TW-5303	1
24-10x	ER345712	Carbon/R. RD1/4 22k(J)	35-9-5	4	25-78x	SP566043	Amp. Panel D (Black)	TW-5303	1
24-11x	ES446973	Slide SW. SL-242B4D	25-3-51	1	25-82x	EM570216	VU Meter R-55 437B16 (Yellow)	46-2-20	4
24-14x	EZ549922	Amp. Chassis D, w/prop	TW-5301	1	25-83x	EM565503	VU Meter R-55 437B17 (Blue)	46-2-19	4
24-16x	BA570543	Vol. P.C. Board Comp.	TW-5323	1	25-88x	SK549843	Double Knob A	TW-6304	5
24-17x	EV565470	Double/Vol. DJ10A 50 kAx2	36-3-52	4	25-89x	SK549865	Double Knob Rubber Ring A	TW-6306	5
24-19x	ER329308	Carbon/R. RD1/4 47k(J) (Insu. type)	35-9-5	4	25-90x	SK549876	Double Knob B	TW-6307	5
24-27x	EJ565492	Mic. Jack 2PMJIP	31-2-37	4	25-91x	SK548627	Double Knob Upper Rubber Ring	MU-6215	5
24-42x	EZ566032	Amp. Chassis E	TW-5302	1	25-92x	SK531224	Push Button Knob	91-5051	5
24-50x	EJ299823	Mate-N-Lock Cap Housing 6P 1-480276-0	52-1-2	1	25-93x	SK569474	Push Button Knob B	91-5051	1
24-56x	EJ347670	Multi-Jack-3 22p 3250-022-001S	31-4-13	4	25-101x	AA545905	Push Button Bush	98-5061	6
24-57x	EZ441775	Osc. Shield Plate	KF-5003	1	25-102x	SZ457806	Lens Holder	55-5013	4
24-58x	EZ441854	P.C. Board Retainer	KF-5013	1	25-103x	EL569878	Lamp Lens A-2	55-5011	4
24-59x	EZ549775	SW. Base C	TW-5307	1	25-104x	EL549810	Lamp Mask	TW-5320	2
24-60x	ES565446	Lever SW. S-J6398 (Monitor)	25-12-12	1					
24-61x	EZ549764	SW. Base B	TW-5306	1					
24-62x	ES565457	Push SW. iFST-4U-322-3 (Tape Select.)	25-5-114	1					
24-63x	EZ549785	Panel Support B	TW-5308	2					
24-64x	EZ549797	Lamp Holder	TW-5316	4					
24-65x	EZ428117	Rubber Bushing	AA-901	4					
24-66x	EL565468	Pilot Lamp (L/T) 24V 35MA (150M/mx2)	25-1-24	4					
24-67x	EZ566054	Shield Plate	TW-5309	1					
24-71x	MH441786	P.C. Board Retaining Prop	KF-5004	3					
24-72x	EZ411287	P.C. Board Retaining Parts	LF-5027	2					
24-75x	SP578891	Amp. Panel E	TW-5303	1					
24-76x	SP566043	Amp. Panel D (Black)	TW-5303	1					
24-82x	EM570216	VU Meter R-55 437B16 (Yellow)	46-2-20	4					
24-83x	EM565503	VU Meter R-55 437B17 (Blue)	46-2-19	4					
24-88x	SK549843	Double Knob A	TW-6304	5					
24-89x	SK549865	Double Knob Rubber Ring A	TW-6306	5					
24-90x	SK549876	Double Knob B (Upper)	TW-6307	5					
24-91x	SK548627	Double Knob Upper Rubber Ring	MU-6215	5					
24-92x	SK531224	Push Button Knob	91-5051	5					
24-93x	SK569474	Push Button Knob B	91-5051	1					
24-94x	AA545905	Push Button Bush	98-5061	6					
24-95x	SZ457806	Lens Holder	55-5013	4					
24-96x	EL569878	Lamp Lens A-2	55-5011	4					
24-97x	EL549810	Lamp Mask	TW-5320	2					

When ordering parts, please describe Parts Number, Serial Number, and Model Number in detail.

GX-400-SS

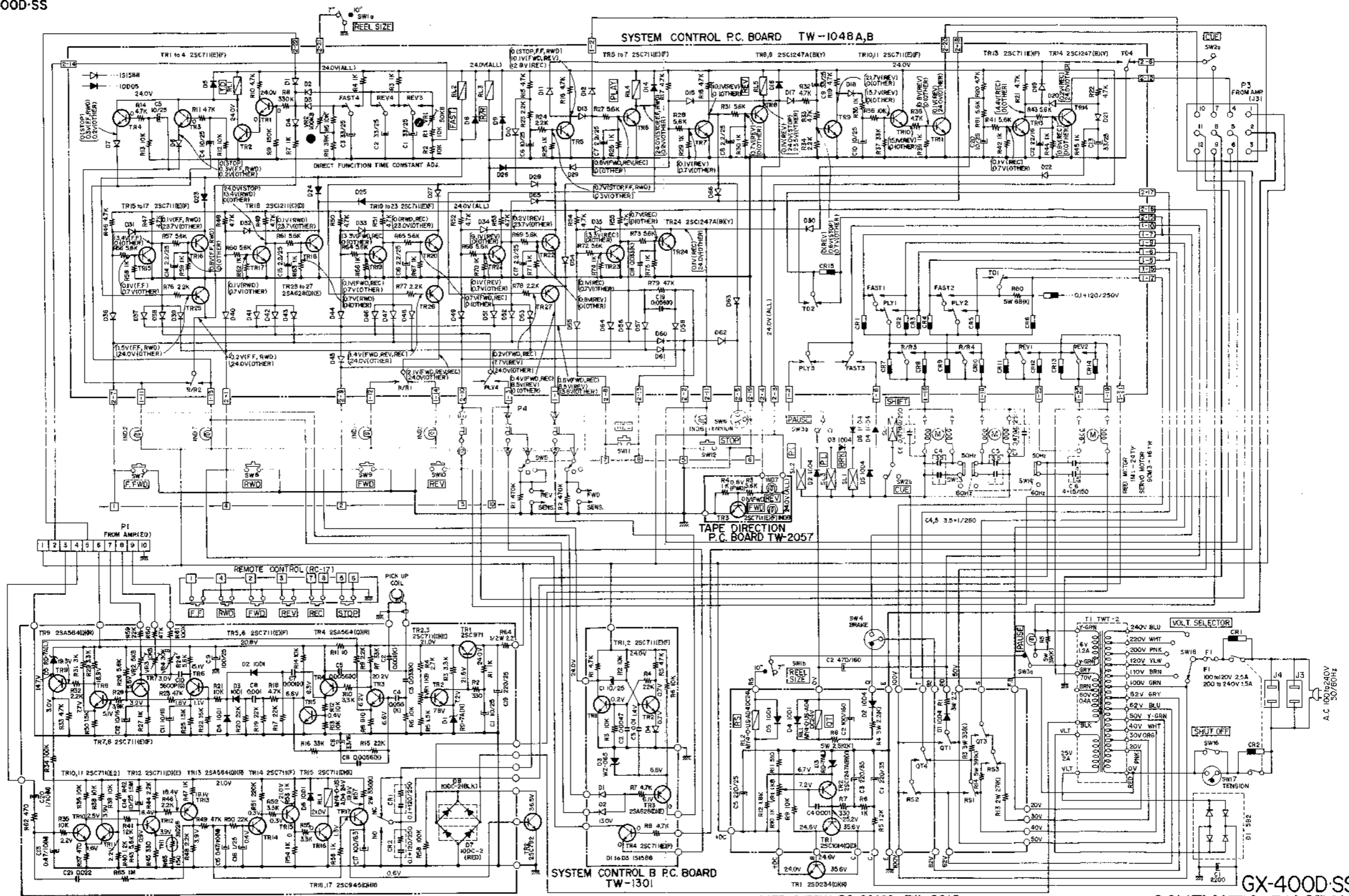

SERVO CONTROL P.C. BOARD TW-1049

SYSTEM CONTROL B P.C. BOARD TW-130

POWER SUPPLY P.C. BOARD TW-2018

NOTE
 UNLESS OTHERWISE SPECIFIED
 ALL RESISTORS IN Ω (1/4W.)
 ALL CAPACITORS IN μF (50V, L)

GX-400-SS
 SCHEMATIC DIAGRAM
 NO.3-1 1481624A

.

-

4
T
C
E

-

E

S

S

-

Z

-

E

I

E

-

-

-

-

-

-

-

-

-

-

-

-

-

-

GX-400D-SS

TAPE SPEED & EQ SWITCH P.C. BOARD TW-5310

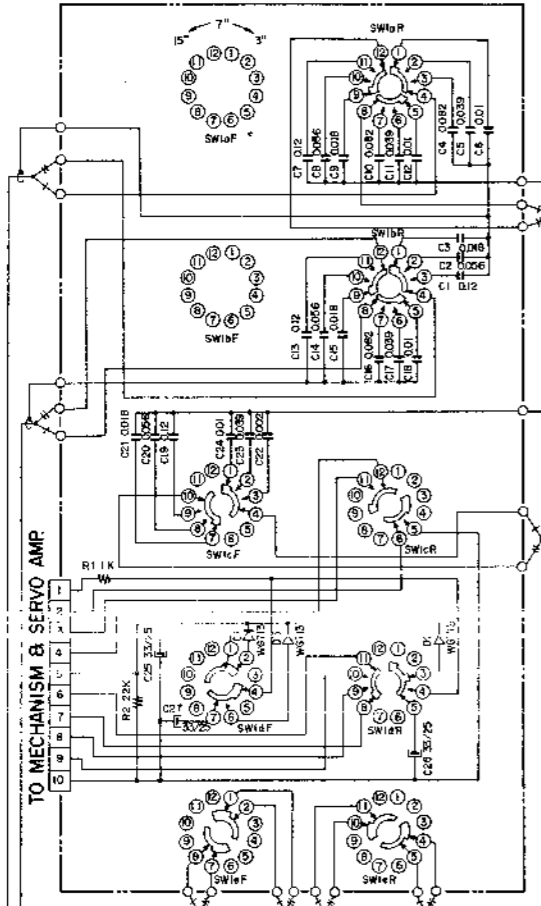

TO MECHANISM & SERVO AMP.

LOW NOISE
NORMAL
TAPE SELECTOR

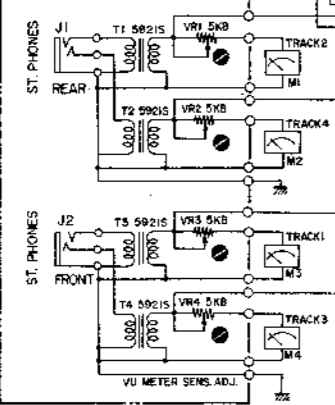

HEAD PHONE P.C. BOARD TW-5312

REC. & ERASE HEADS
TO P.B. HEADS

DUMMY P.C. BOARD TW-5315

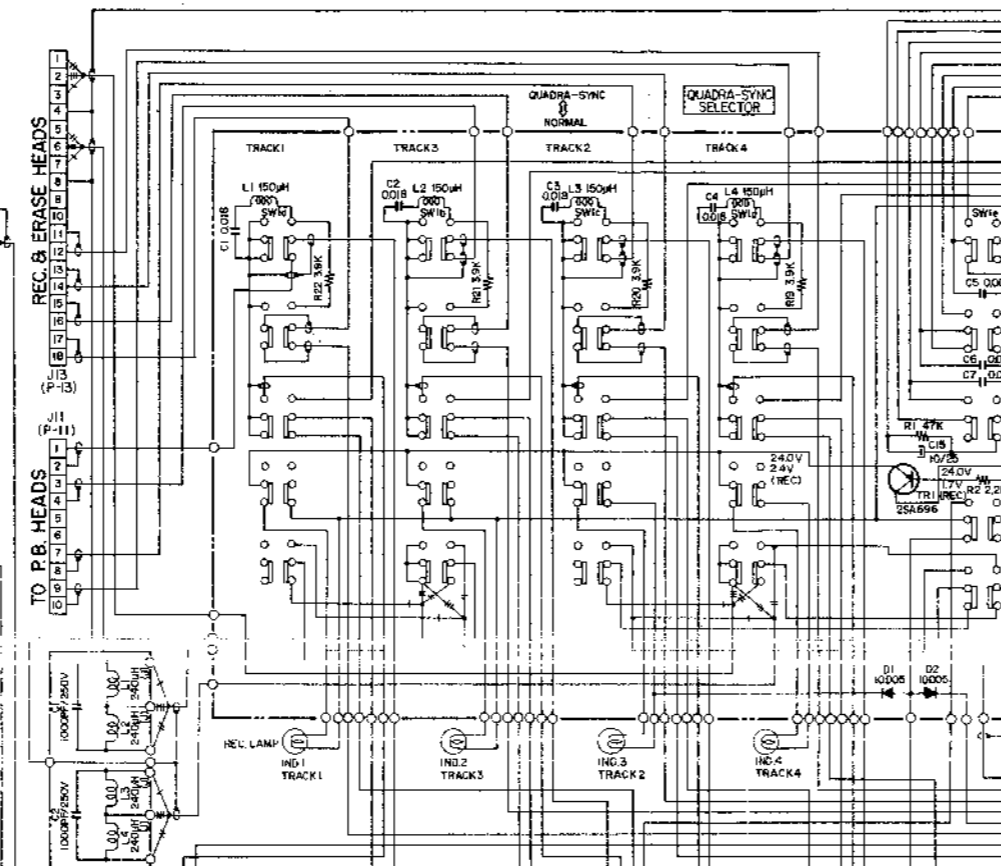

REAR P.B. AMP P.C. BOARD TW-5314
FRONT P.B. AMP P.C. BOARD TW-5314

VOLUME CONTROL P.C. BOARD TW-5323

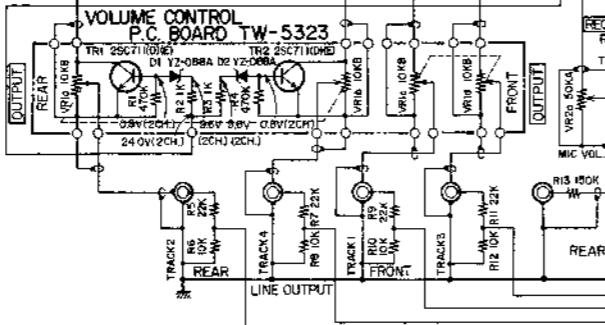

MONITOR
SOURCE
TAPE

REAR REC. AMP P.C. BOARD MS-5023
FRONT REC. AMP P.C. BOARD MS-5023

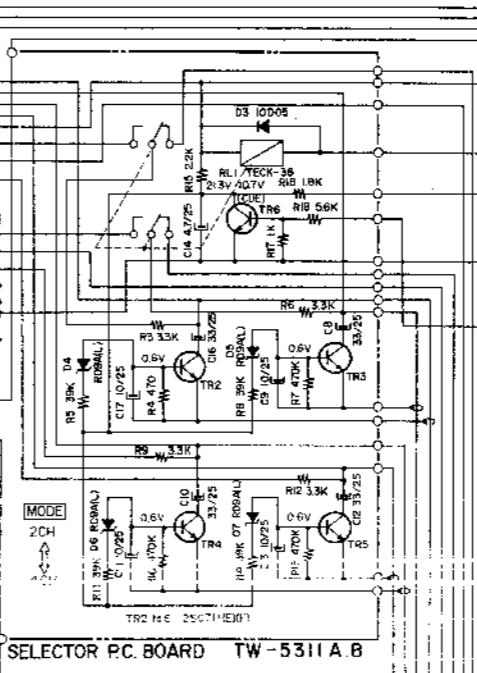

SELECTOR P.C. BOARD TW-5311 A B

ERASE HEADS

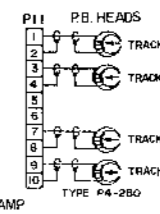
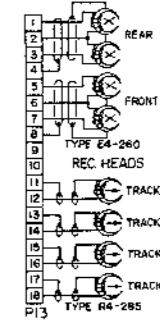

NOTE
UNLESS OTHERWISE SPECIFIED
ALL RESISTORS IN Ω 1/4W(Ω)
ALL CAPACITORS IN μF 50WV(Ω)

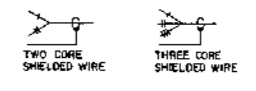

GX-400D-SS
SCHEMATIC DIAGRAM
NO.3-2 1481625A

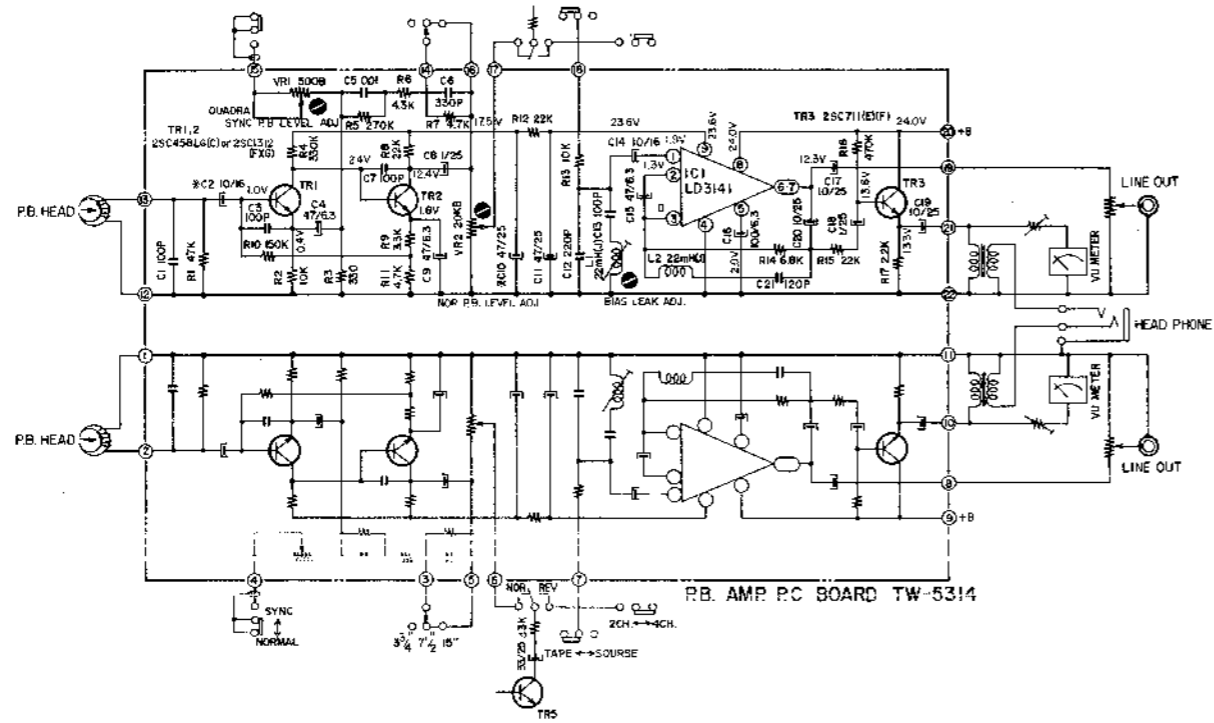

RB AMP PC BOARD TW-5314

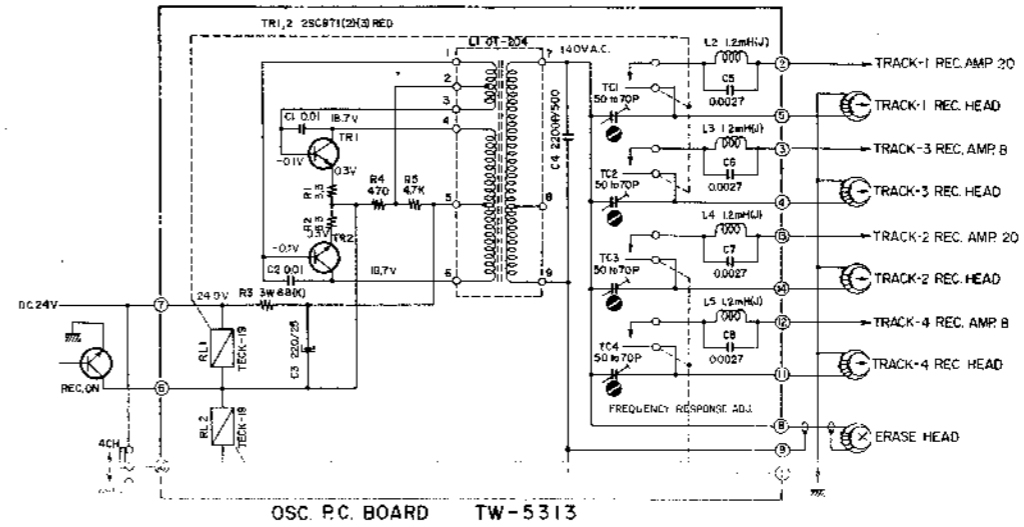

OSC. P.C. BOARD TW-5313

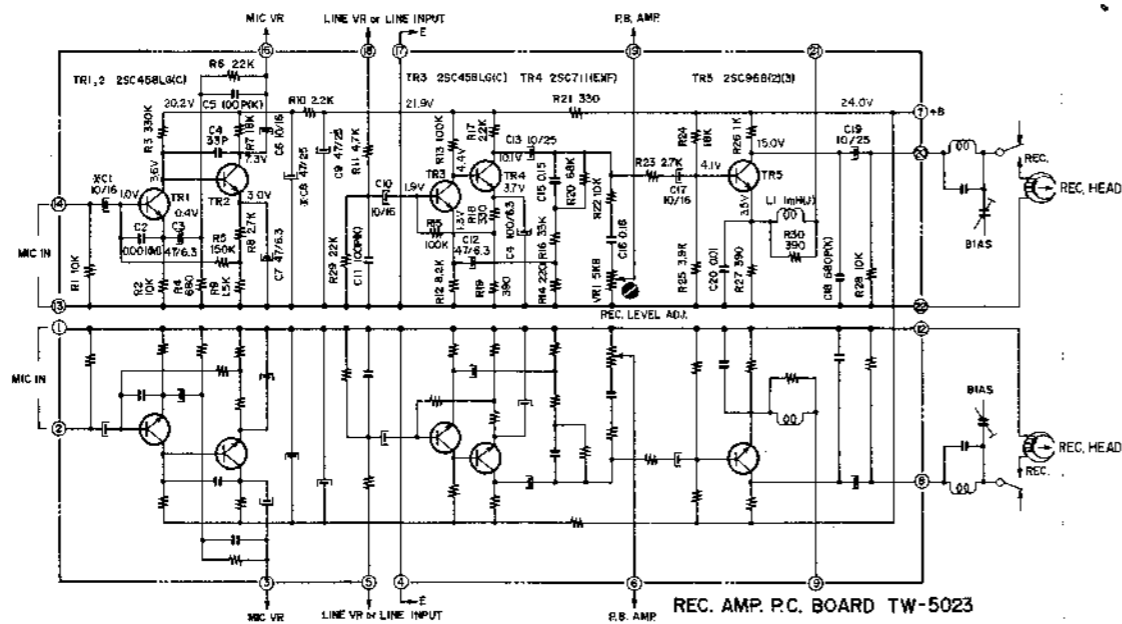

REC. AMP PC BOARD TW-5023

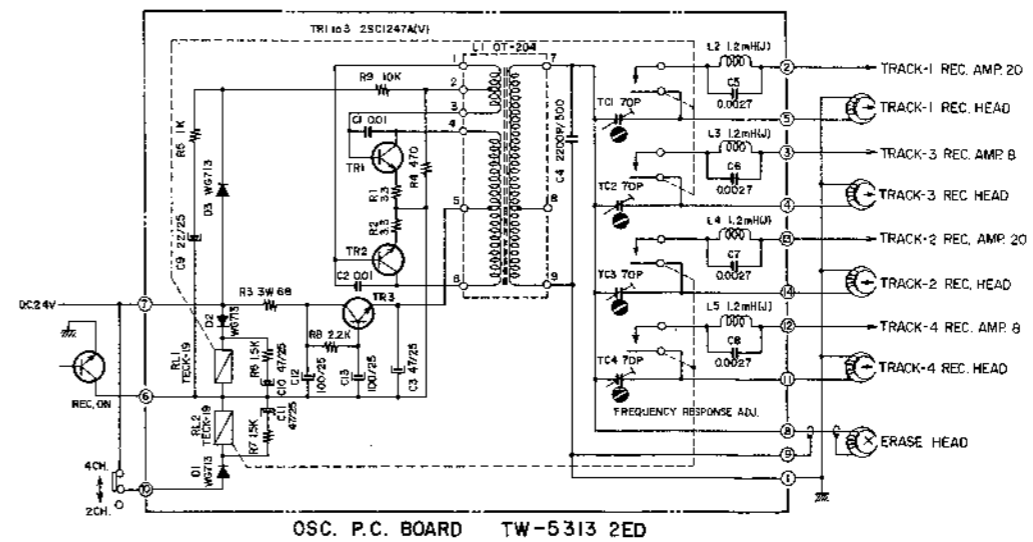

OSC. P.C. BOARD TW-5313 2ED

NOTE
 1. UNLESS OTHERWISE SPECIFIED
 ALL RESISTORS IN Ω, 1/4W(1/2)
 ALL CAPACITORS IN μF 50V(50V)
 2. * MARK INDICATES LOW LEAKAGE CAPACITORS

INDEX

Parts No.	Ref. No. & Symbol No.	Parts No.	Ref. No. & Symbol No.	Parts No.	Ref. No. & Symbol No.	Parts No.	Ref. No. & Symbol No.	Parts No.	Ref. No. & Symbol No.
AA545905	24-94x	EC379192	18-C11	ER212883	11-R5	ET446736	13-TR5		
AA545905	25-101x	EC379192	18-C17	ER212883	11-R7,8	ET453486	10-TR11		
BA565705	10-1x	EC379192	18-C23	ER212883	12-R7	ET453486	11-TR1,2		
BA565716	11-1x	EC379765	14-C5to8	ER212883	12-R11	ET453486	11-TR4		
BA565738	14-1x	EC383501	13-C2	ER212883	13-R11	ET453486	13-TR4		
BA565740	12-1x	EC389485	18-C3	ER213030	19-R18	ET453486	19-TR2to6		
BA565762	8-1x	EC389485	18-C9	ER213300	13-R4	ET453486	21-TR1,2		
BA565773	19-1x	EC389485	18-C15	ER213647	24-9x	ET515880	19-TR1		
BA565784	22-1x	EC389485	18-C21	ER213873	24-5x	ET520288	14-TR1to3		
BA565795	23-1x	EC399690	13-C4	ER214536	24-7x	ET538110	11-TR3		
BA565806	13-1x	EC399734	18-C1	ER304378	14-R4	EV398812	13-VR1		
BA570543	21-1x	EC399734	18-C7	ER306360	12-R14	EV464207	23-VR1to4		
BA570543	24-16x	EC399734	18-C13	ER315944	14-R1,2	EV497698	12-VR2		
BH565661	1-1x	EC399734	18-C19	ER324641	18-R1	EV497711	12-VR1		
BP565683	8-1x	EC423033	13-C18	ER329308	24-19x	EV565470	24-17x		
BP565694	8-2x	EC425250	14-TC1to4	ER336442	11-R2, 3	EV570554	24-VR1		
BT247768	23-T1 to 4	EC432810	12-C2	ER336442	11-R6	EZ411287	24-72x		
BZ565751	24-1x	EC432810	13-C1	ER336442	12-R2	EZ428117	24-65x		
EA441685	1-34x	EC438041	18-C4	ER336442	12-R13	EZ441775	24-57x		
EA496258	12-2	EC438041	18-C10	ER336442	13-R1,2	EZ441854	24-58x		
EC220151	14-C12,13	EC438041	18-C16	ER336442	13-R22	EZ534172	18-2		
EC220612	19-C8	EC438041	18-C22	ER336442	13-R28	EZ549764	24-61x		
EC220612	19-C10	EC450055	12-C8	ER336442	14-R9	EZ549775	24-59x		
EC220612	19-C12	EC450055	12-C18	ER343078	13-R8	EZ549786	24-63x		
EC220612	19-C16	EC450527	19-C14	ER343078	13-R23	EZ549797	24-64x		
EC220678	14-C3	EC456041	18-C25to27	ER345712	12-R12	EZ549808	22-2		
EC220994	11-C1	EC476965	12-C10	ER345712	18-R2	EZ549922	24-14x		
EC220994	12-C17	EC476965	13-C8	ER345712	24-10x	EZ549977	19-2		
EC220994	12-C19,20	EC565560	22-C1, 2	ER345756	24-6x	EZ566032	24-42x		
EC220994	13-C13	ED494583	19-D1to3	ER346601	12-R1	EZ566054	24-67x		
EC220994	13-C19	ED515790	14-D1to3	ER346601	19-R1	HA549944	1-21x		
EC220994	13-C2	ED515796	14-D1to5	ER346994	15-R7	HE563226	1-19x		
EC220994	13-C11	ED520762	19-D4to7	ER346994	13-R24	HE563281	1-17x		
EC220994	19-C13	ED520762	21-D1,2	ER349784	13-R19	HR565672	1-18x		
EC220994	19-C15	ED555895	11-D3	ER349784	13-R27	MH441786	24-71x		
EC220994	19-C17	ED557447	10-D64to66	ER349784	13-R30	SK531224	24-92x		
EC250604	19-C5to7	ED557447	11-D1,2	ER349907	13-R16	SK531224	25-92x		
EC250841	12-C5	ED557447	11-D4	ER349942	13-R12	SK548627	24-91x		
EC250841	13-C20	EF412413	12-IC1	ER350100	13-R20	SK548627	25-91x		
EC250841	14-C1, 2	EJ299823	24-50x	ER352045	13-R25	SK549843	24-88x		
EC250841	18-C6	EJ347670	24-56x	ER352045	19-R19to22	SK549843	25-88x		
EC250841	18-C12	EJ437321	23-J1,2	ER357412	13-R14	SK549865	24-89x		
EC250841	18-C18	EJ565492	24-27x	ER357456	12-R8	SK549865	25-89x		
EC250841	18-C24	EL549810	24-97x	ER357456	13-R10	SK549876	24-90x		
EC250885	11-C3	EL549810	25-104x	ER357456	13-R17	SK549876	25-90x		
EC290520	12-C1	EL565468	24-66x	ER357456	14-R8	SK549933	25-66x		
EC290520	12-C3	EL569878	24-96x	ER357456	19-R2	SK569474	24-93x		
EC290520	12-C7	EL569878	25-103x	ER357456	19-R15	SK569474	25-93x		
EC290520	12-C13	EM565503	24-83x	ER357535	19-R5	SM549742	25-21x		
EC290531	13-C5	EM565503	25-83x	ER357535	19-R8	SM549753	25-23x		
EC290531	13-C11	EM570216	24-82x	ER357535	19-R11	SP565637	25-1x		
EC302297	19-C1to4	EM570216	25-82x	ER357535	19-R14	SP566043	24-76x		
EC310792	12-C21	EO243977	13-L1	ER357570	12-R10	SP566043	25-78x		
EC320051	12-C14	EO244012	12-L2	ER357570	13-R5	SP566177	25-51x		
EC320051	13-C6	EO346230	12-L1	ER362441	19-R16	SP578891	24-75x		
EC320051	13-C10	EO383365	14-L1	ER362485	12-R4	SP578891	25-77x		
EC320051	13-C17	EO424866	14-L2to5	ER362485	13-R3	SZ457806	24-95x		
EC329771	12-C4	EO565558	22-L1to4	ER364948	19-R3	SZ457806	25-102x		
EC329771	12-C9	EO575482	19-L1to4	ER364948	19-R6	ZS323728	19-3		
EC329771	12-C15	EP315461	14-RL1,2	ER364948	19-R9	ZS323728	22-3		
EC329771	13-C3	EP383321	19-RL1	ER364948	19-R12	ZS325495	18-3		
EC329771	13-C7	ER211320	13-R9	ER364972	14-R7				
EC329771	13-C12	ER211320	14-R6	ER426857	12-R5				
EC329850	12-C12	ER211465	13-R26	ER427972	14-R3				
EC333562	13-C16	ER211465	14-R5	ER429996	12-R16				
EC336104	12-C16	ER211465	19-R17	ER429996	19-R4				
EC336104	13-C14	ER211465	21-R2,3	ER429996	19-R7				
EC336126	12-C11	ER211757	13-R13	ER429996	19-R10				
EC336126	13-C9	ER211757	13-R15	ER429996	19-R13				
EC336126	14-C10,11	ER212264	13-R4	ER430288	24-8x				
EC336216	12-C6	ER212264	12-R15	ER443790	21-R1				
EC346522	14-C4	ER212264	12-R17	ER443790	21-R4				
EC350684	14-C9	ER212264	13-R6	ER446973	24-11x				
EC362158	11-C2	ER212264	13-R29	ES565446	24-60x				
EC368357	18-C2	ER212477	12-R9	ES565457	24-62x				
EC368357	18-C8	ER212681	12-R3	ES565536	19-SW1				
EC368357	18-C14	ER212681	13-R18	ES591603	18-SW1				
EC368357	18-C20	ER212681	13-R21	ET234854	12-TR1,2				
EC368370	13-C15	ER212872	12-R6	ET234854	13-TR1,2,3				
EC379192	18-C5	ER212883	11-R1	ET398711	12-TR3				