

AKAI

CR80DSS

---

MODEL

---

SERVICE MANUAL

---

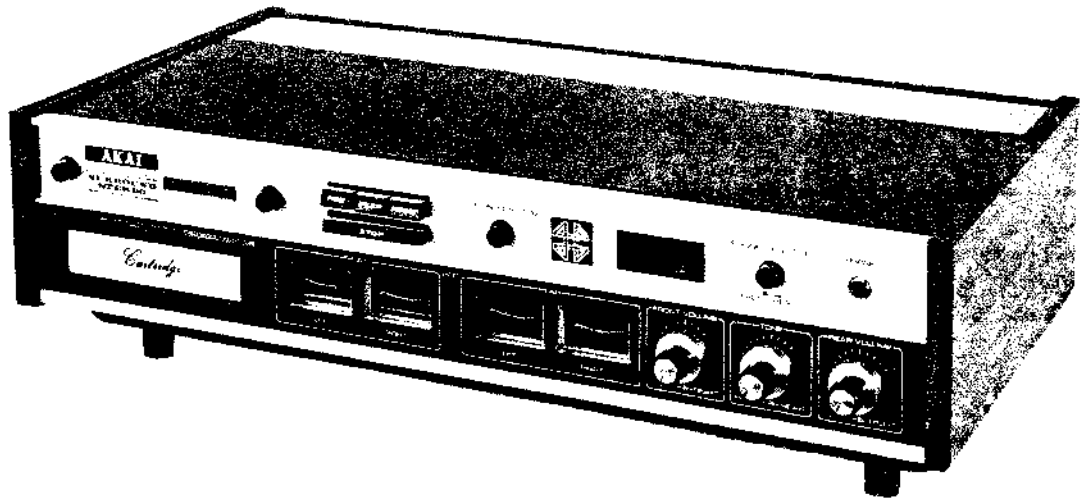

## TABLE OF CONTENTS

|       |  |    |
|-------|--|----|
| I.    | SPECIFICATIONS .....   | 2  |
| II.   | MEASURING METHODS .....  | 3  |
| III.  | DISMANTLING OF TAPE TRANSPORT<br>UNIT & AMPLIFIER .....            | 5  |
| IV.   | HEAD ADJUSTMENTS .....   | 6  |
| V.    | MECHANISM ADJUSTMENTS .....  | 7  |
| VI.   | AMPLIFIER ADJUSTMENTS .....  | 9  |
| VII.  | OPERATING PRINCIPLES OF PROGRAM<br>SELECTOR & MAGNETIC BRAKE ..... | 11 |
| VIII. | COMPOSITE VIEWS OF COMPONENTS .....                                | 13 |

When placing order for parts,  
please use separate PARTS LIST.

---

# I. SPECIFICATIONS

An asterisk next to a figure, indicate the minimum guaranteed performance.

## RECORDING SYSTEM

8-Track 4-channel/2-channel compatible stereo recording

## PLAYBACK SYSTEM

8-Track 4-channel/2-channel compatible stereo playback

## TAPE SPEED

Play/Rec: 3-3/4 ips ( $\pm 2\%*$ )

Fast Forward: 15 ips  $\pm 10\%$

## WOW AND FLUTTER

Less than 0.25% (0.35%\*) rms

## FREQUENCY RESPONSE

30 to 16,000 Hz  $\pm 3$  dB (30 to 15,000 Hz  $\pm 3$  dB\*)

## SIGNAL TO NOISE RATIO

Better than 47 dB (41 dB\*)

## DISTORTION

Within 2% (3%\*) at 1,000 Hz. "0" VU Recording

## CROSS TALK

Less than -40 dB

## ERASE RATIO

Less than -60 dB

## OUTPUT

### LINE OUTPUT

1.228 V (+4 dB)  $\pm 1.5$  dB using a 500 Hz "0" VU

Recorded Tape (Required load impedance more than 20 k $\Omega$ )

### DIN OUTPUT

0.4 V

### PHONE OUTPUT

30 mV at 8  $\Omega$  (CR-80D-SS), variable (CR-80-SS)

### SPEAKER OUTPUT

More than 7 W each channel at 8  $\Omega$  (CR-80-SS only)

## INPUT

### LINE INPUT

100mV (Impedance 150 k $\Omega$ )

### DIN INPUT

15mV (Impedance 30 k $\Omega$ )

### MIC INPUT

0.5mV (Impedance 5 k $\Omega$ )

## MOTOR

Condenser starting induction two-speed (2-8 pole) Motor

Condenser Capacity: 4  $\mu$ F (50 Hz); 2.5  $\mu$ F (60 Hz)

Revolutions: 2900 to 725 rpm (50 Hz)

3480 to 870 rpm (60 Hz)

## RECORDING CAPACITY

20/40 min. 4-ch/2-ch stereo recording using a 200 ft. cartridge tape

## FAST FORWARD TIME

75 seconds using a 200 ft. cartridge tape

## RECORDING AND PLAYBACK HEAD

In-line 8 track 4-channel stereo (8-track 2-channel stereo)

Impedance: 650  $\Omega$  at 1 kHz

Gap: 2/1000 mm

## ERASE HEAD

In-line 8-track 4-channel stereo (8-track 2-channel stereo)

Impedance: 110  $\Omega$   $\pm 10\%$  at 60 kHz

Gap: 0.3 mm

## OSCILLATION FREQUENCY

61  $\pm 3$  kHz

## TRANSISTORS

## TRANSISTORS USED

8 ..... 2SC693U (F)

6 ..... 2SC711 (D)

2 ..... 2SC971 (2) (3) Red

1 ..... 2SC968 (4)

1 ..... 2SC1014 (B) (C)

1 ..... 2SC1061 (A) (B) (C)

## IC USED

4 ..... LD3141

4 ..... STK-011 (CE-80-SS only)

## DIODES USED

8 ..... 10D1

1 ..... 10D2

8 ..... 1N34A

1 ..... 5B2 (CR-80-SS only)

1 ..... 10DC1 (Blk) (CR-80D-SS only)

## POWER SUPPLY

100 to 240 V AC; 50/60 Hz.

## POWER CONSUMPTION

75W (CR-80-SS); 50W (CR-80D-SS)

## INSULATION RESISTANCE

More than 50 M $\Omega$

## INSULATION DURABILITY

1,000 V AC for more than one minute duration

## DIMENSIONS

485(W) x 138(H) x 280(D) mm (19.4 x 5.5 x 11.2")

## WEIGHT

CR-80-SS: 12 kg. (26 lbs.)

CR-80D-SS: 11 kg. (24 lbs.)

## II. MEASURING METHODS

### TAPE SPEED DEVIATION

Method involving use of pre-recorded tape.

Playback a tape pre-recorded at 1000 Hz ( $\pm 0.1\%$ ) on recorder to be tested. Connect the appropriate output to a frequency counter in order to measure the tape speed deviation.

### WOW AND FLUTTER

Playback a 3,000 Hz pre-recorded tape of which the wow and flutter level is guaranteed to be smaller than 0.07% for measurement by means of a wow meter. It is also possible for a 3,000 Hz sine wave to be recorded and played for measurement by means of the wow meter. In this case, however, the wow meter indicates a value as much as twice the value given in the specifications.

### SIGNAL TO NOISE RATIO

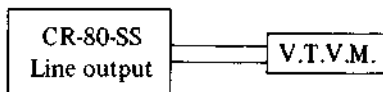

Playback a tape containing a 1,000 Hz sine wave recorded at "0" VU level on a standard recorder. Connect a V.T.V.M. to the line output jack of the recorder and measure its output.

Then remove the tape and measure the noise level under the same condition. Convert each of the measured values into decibels.

### TOTAL HARMONIC DISTORTION FACTOR

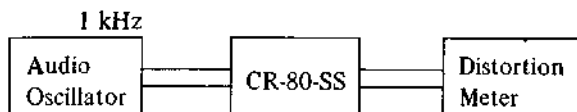

Connect the measuring instrument as shown above, and record a 1,000 Hz sine wave at "0" VU. Playback the resultant signal and measure the overall distortion factor. Measure the noise level of the tape recorder with the tape removed; connect the audio oscillator directly to the distortion meter for measurement of the distortion factor of the oscillator.

The required distortion factor can be obtained from the results of the above measurement by the following formula.

$$d_0 = d - d_1 - d_2$$

where,  $d_0$  = Required  
 $d$  = Overall distortion factor  
 $d_1$  = Noise level  
 $d_2$  = Distortion factor of the oscillator

(Note: New tape of particularly good quality should be used for measurement of the distortion factor. (AKAI) "L" tape is recommended).

### POWER OUTPUT

Playback a tape containing a sine wave of 500 Hz recorded at 0 VU on a standard recorder.

Measure the voltage at the speaker output of the recorder to be tested when terminated with  $8 \Omega$ .

Then use the following formula:

$$P = \frac{E^2}{R}$$

$P$  = Desired output (W)  
 $E$  = Measured Voltage  
 $R$  =  $8 \Omega$

### FREQUENCY RESPONSE

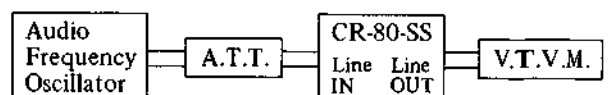

Connect the measuring instrument as in the above diagram, and measure the frequency response in the following sequence:

RECORD:

- 1) Supply a sine wave of 1,000 Hz to the Line Input of the recorder to be tested through an attenuator from an audio frequency generator.
- 2) Set the Recorder to Recording Mode and adjust the line input volume so that the VU meter needle indicates "0" VU.
- 3) Under the condition described in (2), lower the input level 20 dB by means of the attenuator.
- 4) Record the spot frequency in the range of 30 Hz to 15,000 Hz from the audio frequency generator.

PLAYBACK:

- 5) Depress Play Button.
- 6) Connect a High sensitivity V.T.V.M. to the Line output.
- 7) Playback the tape previously recorded. Make memo of output level and plot the value on a graph.

Note: (New tape of particularly good quality should be used for measurement of the frequency response. (AKAI) "U" tape is recommended).

**CROSS TALK:**

Cross talk between the channels. (TAPE)

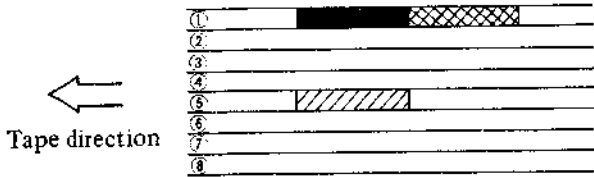

As shown in the figure (above), first record a 1,000 Hz sine wave on track No. 1 at +3 VU level. Next, record under a non-input condition.

Then, playback the tape on track No. 1 and No. 5 through the 1,000 Hz B.P.F. (Band Pass Filter, Sensitivity ... 1:1) and obtain a ratio between the two from the following formula.

$$C = 20 \log \frac{E_0}{E_2 - E_1} \text{ (dB)}$$

C = Desired cross-talk ratio (dB)

E<sub>0</sub> = 1,000 Hz signal output level

E<sub>2</sub> = 1,000 Hz cross-talk output level

E<sub>1</sub> = Non-input signal record level



In case of trouble, etc. necessitating disassembly, please disassemble in the order shown in photographs. Reassemble in reverse order.

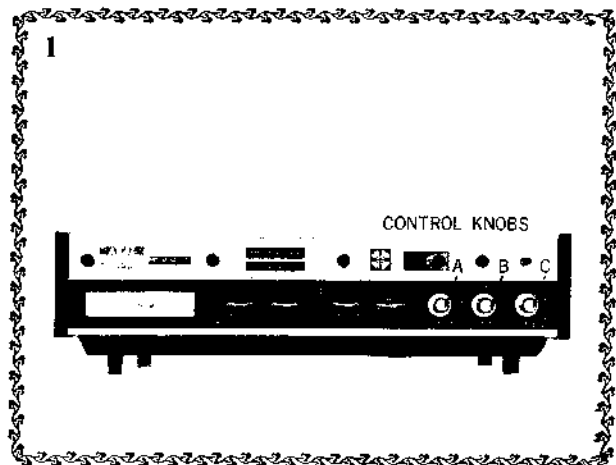

### III. DISMANTLING OF TAPE TRANSPORT UNIT AND AMPLIFIERS

2



6

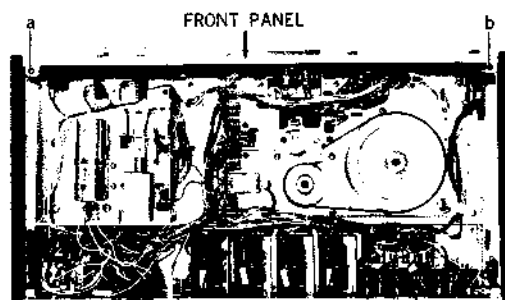

3

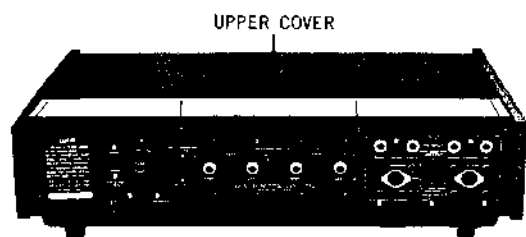

7

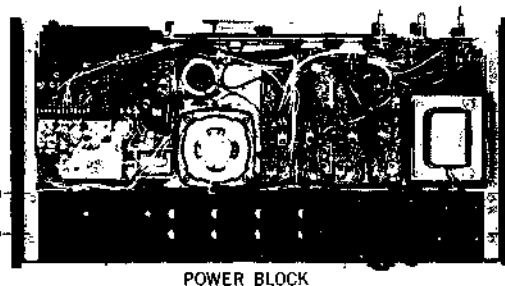

4

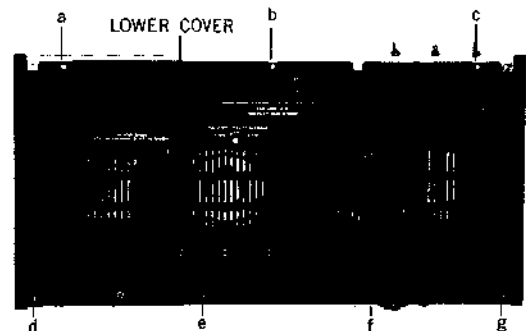

8

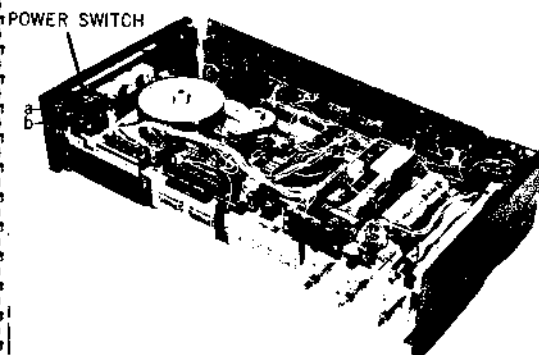

5

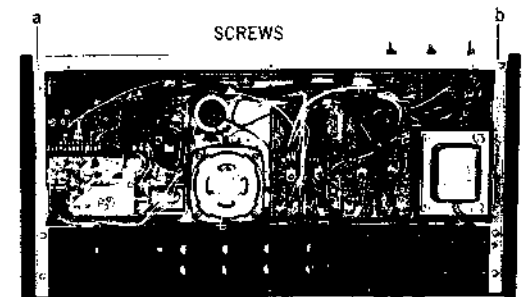

9

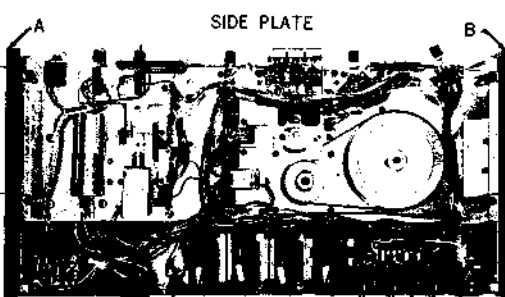

## IV. HEAD ADJUSTMENTS

### 1. HEAD ANGLE ADJUSTMENT

- 1) Connect a High Sensitivity V.T.V.M. (Model 161A) to the Line Output.
- 2) Playback Program 3 of an 8,000 Hz. pre-recorded Tape and adjust Screw "c" shown in Fig. 1 so that the V.T.V.M. indication is maximum.

### 2. HEAD HEIGHT AND CROSS TALK ADJUSTMENT

- 1) Connect a High Sensitivity V.T.V.M. (Model 161A) to the Line Output.
- 2) Set 4-Ch/2-Ch Channel Selector to "2-Ch" position.
- 3) Playback Program 2 of \*Test Tape and adjust Screw "d" shown in Fig. 1 so that the V.T.V.M. indication is minimum.
- 4) In case of CR-80-SS, connect speaker to speaker jack and with volume control turned to maximum, adjust Screw "d" until the sound emitted from the speaker is minimized.
- 5) The adjustments outlined in items 2) and 3) above will result in ideal head height position and minimize cross-talk.

#### \* Test Tape

This Test Tape is a tape specially designed by AKAI for Head Height and Cross-Talk Adjustment tests.

|           |           |
|-----------|-----------|
| Program 1 | 1,000 Hz. |
| Program 2 | Blank     |
| Program 3 | 1,000 Hz. |
| Program 4 | 3,000 Hz. |

- 4) After the above adjustment has been carried out, it is necessary to re-adjust Head Heights and Cross-Talk. Use a \*Test Tape and make the adjustments outlined in items 2-2) and 2-3) again.

#### \* Blank Test Tape

This is also a special tape designed by AKAI. Duration of tape is only 15 seconds.

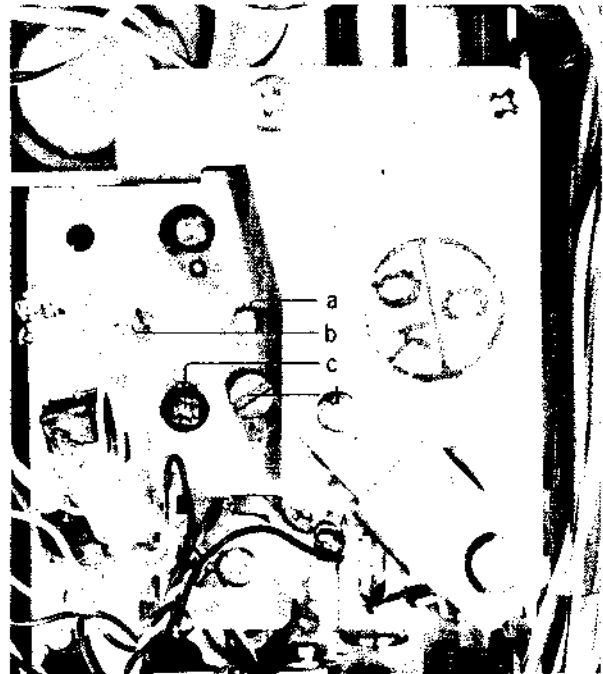

Fig. 1

### 3. CONFIRMATION OF HEAD HEIGHT

- 1) Record a 1 kHz "0" VU signal on a \*Blank Test Tape. Next, run the tape under a non-signal input condition. Then play back the tape.
- 2) At this time check to see whether or not the recorded sound is emitted from the speaker or line output.
- 3) If no signal or no sound is emitted, the height of the recording and erase heads are properly adjusted. If the recorded signal has not been perfectly erased and is emitted from the speaker or line output, the recording and erase head height is not properly adjusted and the following adjustment is necessary:

Turn screws "a" and "b" in the same direction and to the same degree and turn screw "c" in the opposite direction to the same degree (see Fig. 2). This fine adjustment screw "c" should not be turned more than 10° and should equal the degree to which screws "a" and "b" have been adjusted.

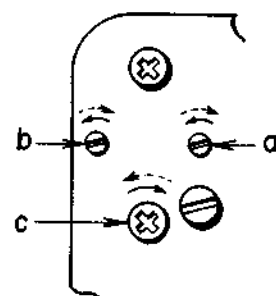

Fig. 2

# V. MECHANISM ADJUSTMENTS

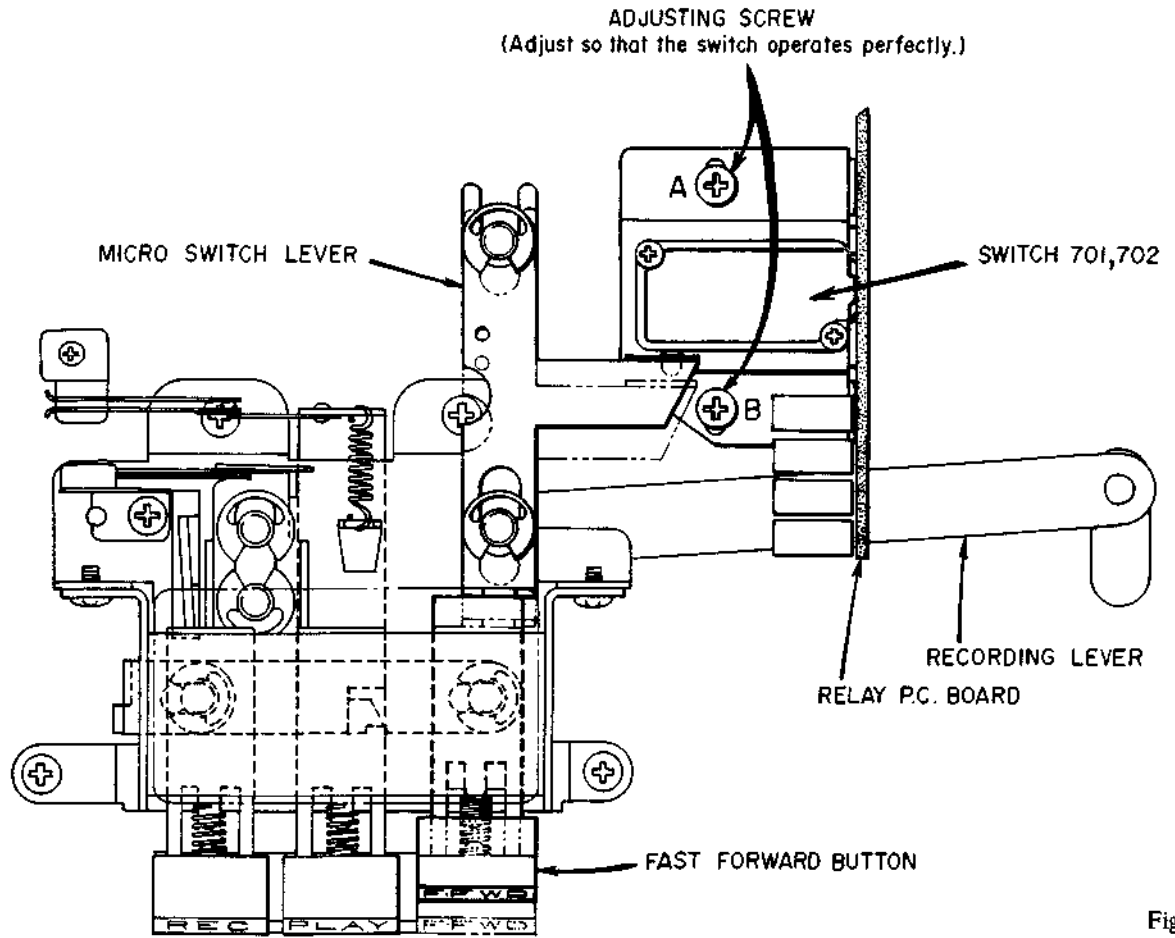

Fig. 3

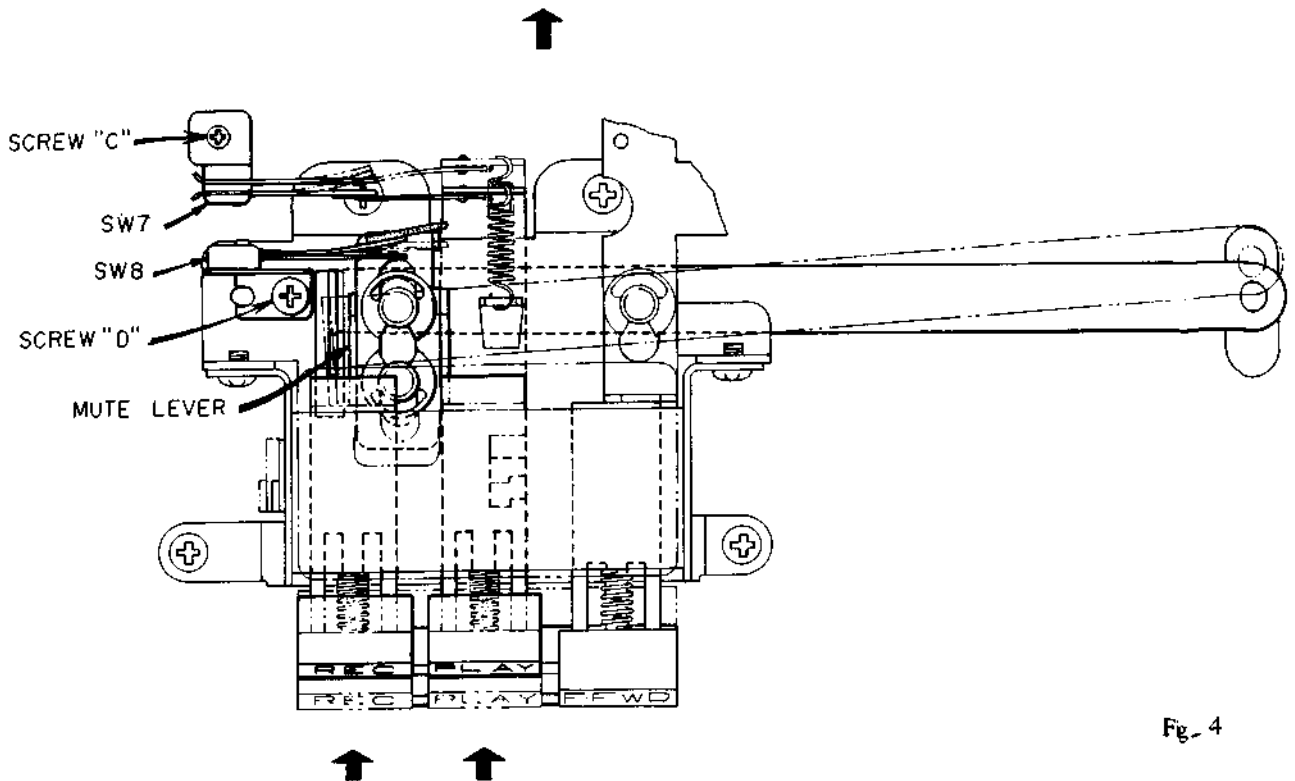

Fig-4



### 1. POSITION ADJUSTMENT OF SWITCHES SW-701 AND SW-702

- 1) Position Relay Print Board and fix Screws "A" "B" in position at which Switches 701, 702 operate perfectly when the Fast Forward Button is depressed.

### 2. ADJUSTMENT OF MUTE SWITCHES (SW-7, SW-8)

- 1) SW-7 closes only while the Stop Button is at depressed position and it should be open when Stop Button is released. If contact point does not work normally, loosen Screw "C" and adjust the angle of SW-7.
- 2) SW-8 opens only while the Play and Rec Buttons are at depressed position. If contact point does not work normally, loosen Screw "D" and adjust the angle of SW-8.

### 3. MUTE LEVER TROUBLE ADJUSTMENT

If the Mute Lever does not return when function is changed from "Rec" or "Play" to Stop Mode, the Mute Switch contact point is remaining open. As a result considerable noise is emitted from the speakers at Stop and F.F. Mode. In this event replace Mute Lever and Mute Switch (see Fig. 5).

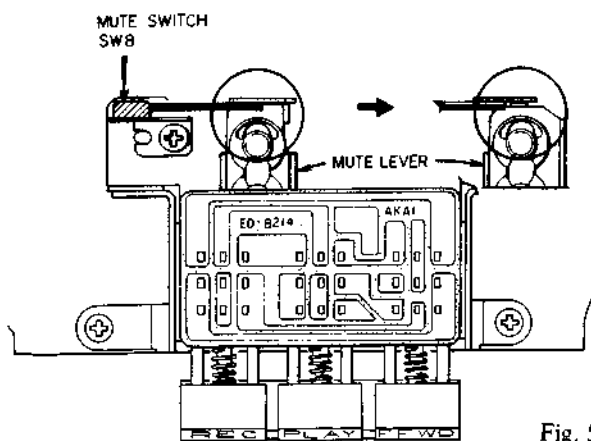

Fig. 5

### 4. ADJUSTMENT OF RECORDING/PLAYBACK SWITCH (SW-1, SW-2) ; SW1, SW2 TROUBLE COUNTERMEASURE

- 1) Position Pre-Amp Print Board so that when the REC Button is depressed, the Recording Lever sets SW1 and SW2 perfectly for effecting recording mode. (SW1 and SW-2 is the Rec - Play Slide Switch).
- 2) If proper adjustment cannot be made by positioning the Pre-Amp. P.C. Board, replace present recording lever with recording levers A and C as shown in Fig. 6. Loosen Screws "E" and "F" and adjust angle of recording lever C.

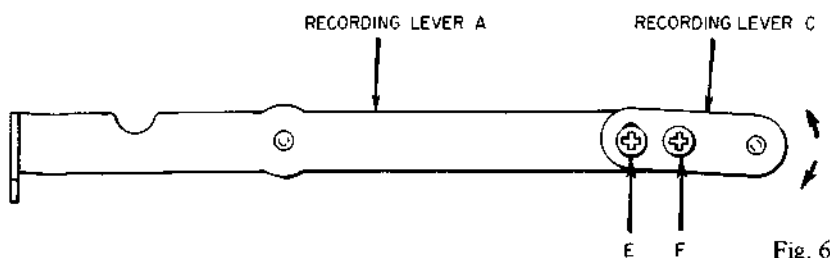

Fig. 6

## VI. AMPLIFIER ADJUSTMENTS

### 1. ADJUSTMENT OF RECORDING BIAS FREQUENCY (See Fig. 7)

- 1) Connect a Frequency Counter to points (A) and (B), and read the Frequency Counter indication.
- 2) If the Frequency Counter reading is  $.61 \text{ kHz} \pm 3 \text{ kHz}$ , the recording bias frequency is correct.
- 3) If the recording bias frequency is incorrect, it can be adjusted by changing the value of condenser C-404.

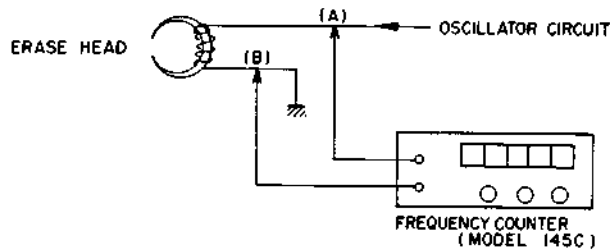

Fig. 7

### 2. ADJUSTMENT OF RECORDING BIAS VOLTAGE (See Fig. 8)

- 1) Connect a V.T.V.M. (Model 107 A Type) to points (2) to (5) and measure the bias voltage.
- 2) Correct recording bias voltage is between 12 and 20 V AC. Adjustment can be made with VR-401 to VR-404 respectively.  
Correct Erase Voltage is between 22 and 23 V AC.

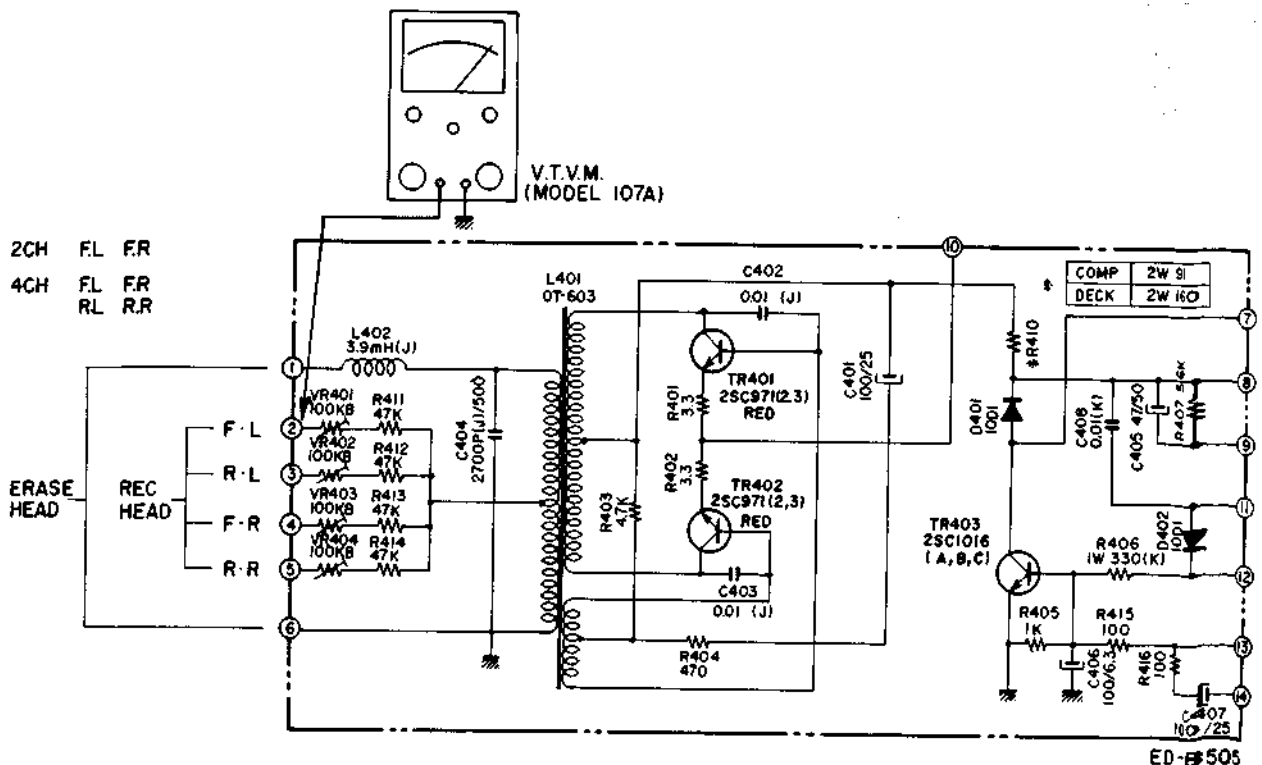

Fig. 8

### 3. ADJUSTMENT OF PLAYBACK LEVEL (See Fig. 9)

- 1) Connect a High-Sensitivity V.T.V.M. (Model 161A) to the Line Output.
- 2) Turn Volume Control (VR-1a 50 K $\Omega$ ) up to maximum (CR-80-SS only).
- 3) Play back a test tape (500 Hz "0" VU Recorded) and turn the Potentiometer VR-1 (30 KB) until the line output level reaches +4 dB (1.228V). (Ref. PRE-AMP. P.C. BOARD ED-B503)

### 4. ADJUSTMENT OF RECORDING AND PLAYBACK LEVEL (See Fig. 9)

- 1) Load a Blank Test Tape.
- 2) Set recorder to recording mode and turn the main volume up to maximum (CR-80-SS only).
- 3) Supply a 1 kHz sine wave signal from an Audio Frequency Oscillator through the attenuator to the line input and adjust the attenuator so that the V.T.V.M. indicates +4 dB (VU Meter needle indicates "0" VU).
- 4) After a few seconds of recording, playback the recorded tape from the starting point and check the V.T.V.M. indication.
- 5) If the line output does not reach +4 dB, repeat recording and playback procedure from item 3) and adjust Potentiometer VR-2 (10- KB) until +4 dB is obtained. (Ref. PRE-AMP. P.C. BOARD ED-B503)

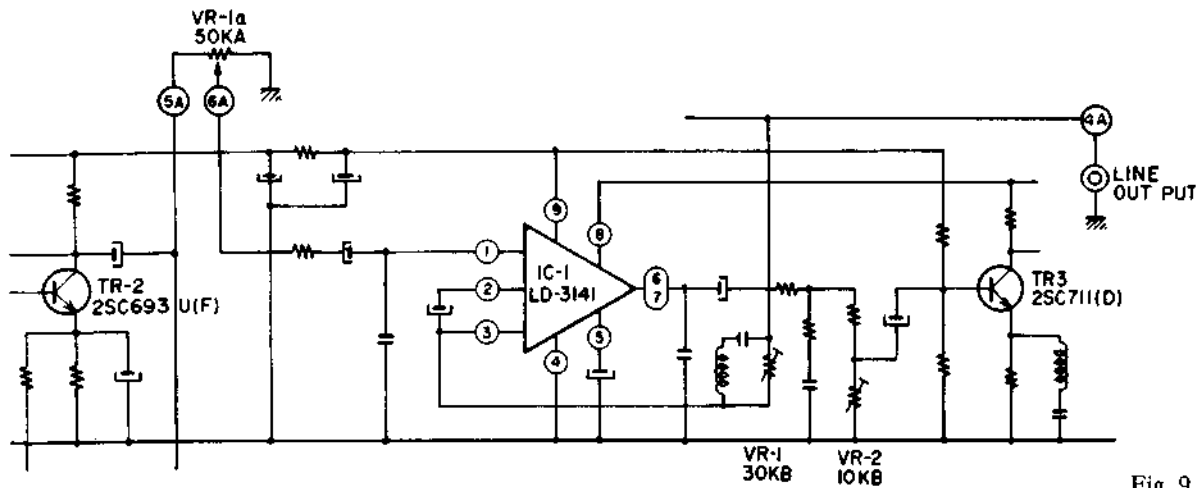

Fig. 9

## 5. 4-CHANNEL PHASE CHECK

### Method A

- 1) Connect front left signal and front right signal from line output terminal to vertical and horizontal input of Oscilloscope (See Fig. 10).
- 2) Playback a Cartridge Test Tape (500 Hz. "0" VU recorded).
- 3) If front left and front right are In-Phase, the waveform as shown in Fig. 11 will appear on the oscilloscope screen.  
If Phase is 180° out of Phase, a waveform as shown in Fig. 12 will appear on the oscilloscope screen.
- 4) Make the same check on front left/rear left and rear left/rear right.
- 5) The various line outputs should be In-Phase. If not In-Phase, recording/playback head lead wire is incorrectly wired or angle of recording/playback head needs adjusting.

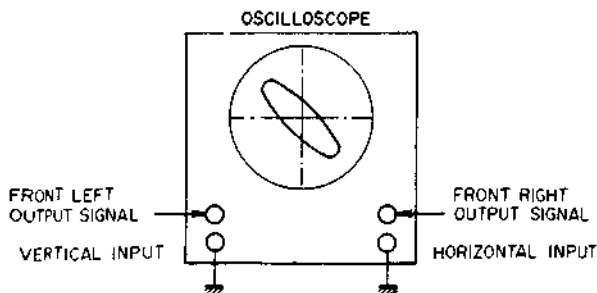

Fig. 10

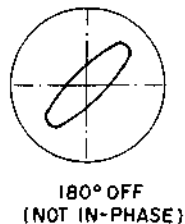
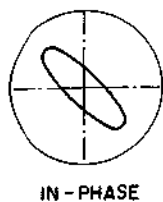

Fig. 11 In-Phase

Fig. 12 180° out of phase

### Method B (See Fig. 13)

- 1) Playback a Cartridge Test Tape (500 Hz "0" VU recorded).
- 2) Connect front left signal and front right signal line output terminals in parallel and connect this to a High Sensitivity V.T.V.M.
- 3) If In-Phase, the output will be about +4 dB.
- 4) At 180° out of phase, the output will be about -5 dB.
- 5) Make the same check on front left/rear left and rear left/rear right.

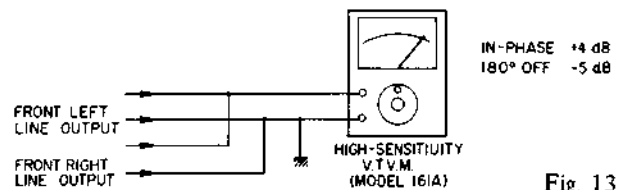

Fig. 13

## VII. OPERATING PRINCIPLES OF PROGRAM SELECTOR & MAGNETIC BRAKE

### 1. PROGRAM SELECTOR (See Fig. 14)

- 1) The Flip-Flop (2 stable multivibrator) Circuit is comprised of TR-701 and TR-702. When the Continuous Play Switch is "off", B+ voltage (6V) is applied only at Program 2.  
Under normal conditions, because of the charge current flowing to C-702, the voltage at the base of TR-701 is decreased, TR-701 is maintained at "off", TR-702 "on", and TR-703 "off".
- 2) At this condition, when the sensing tape passes the sensing post, bias current passes R-407, D-402, and R-406 and flows to TR-403 and TR-403 is turned on.  
Because TR-403 collector current flows through Solenoid PL-1, PL-1 is energized. When PL-1 is energized, Program Selector cam operates and the Program Selector moves to Program 3.
- 3) When the Program Selector moves to Program 3, bias voltage passes D<sub>1</sub>, SW<sub>1</sub>, and SW<sub>2</sub> and flows to TR-403. Thus TR-403 is turned on again, PL<sub>1</sub> is energized, the Program Selector cam is activated, and the Program Selector Switch moves to Program 4.
- 4) At this times, as soon as Solenoid PL-1 is energized on, the lever interlocked with PL-1 turns off micro switch SW-2. When SW-2 is turned off, because a charge current flows to TR-403, TR-403 is held at "on" condition. As the charge current to C-407 decreases, TR-403 is turned off, PL-1 is also turned off and the lever interlocked with PL-1 turns on SW-2. C-407 discharges through R-416 and SW-2.
- 5) When Solenoid PL-1 is turned off, because the Program Selector is switched to Program 4, the bias current passes Diode D<sub>2</sub> and SW<sub>1</sub>, SW<sub>2</sub> and flows to TR-403. Thus, TR-403 is turned "on". Because TR-403 is turned on, PL-1 is again turned on and the Program Selector returns to Program 1. Operating time (in item (3) to (5) above) is very short and switching of program selector from 3-4-1 is very fast.

### 2. MAGNETIC BRAKE (See Fig. 14)

- 1) With Program Selector at Program 2, at the moment the sensing tape passes the sensing post, bias current passes R-407, D-402, and R-703 and flows to the base of TR-701. TR-701 is turned on, TR-702 off, and TR-703 on.  
When TR-703 is turned on, Relay RL-701 is energized, and the motor stops. At the same time, the center point of Relay RL-701 contacts the normal open terminal and a continuous B+ voltage is supplied to TR-701 to TR-703 circuit so that it operates as a lock circuit.
- 2) The use of C-701 prevents the TR-701 to TR-703 circuit B+ voltage from temporarily becoming 0 when Relay RL-701 contact point is switched.
- 3) The use of R-601 circuit (connected to the TR-703 base circuit) serves to implement a B+ voltage supply and hold TR-703 at "on" condition and stop the motor for stop mode. (Because at Stop Mode, the B+ voltage supply passing Relay RL-701 contact point is cut, bias from the Function Switch Stop Circuit is supplied to TR-703 through R-601, TR-703 is held at "on", and the motor stops).
- 4) When the Continuous Play Switch is set to "on" position, although the Selector comes to Program 2 position, because there is no B+ voltage supply at TR-701 to TR-703 circuit and because Relay RL-701 does not operate either, motor revolutions continue for continuous playback.
- 5) When Relay RL-701 is activated at stop mode, a DC current (charged at C-3) flows to the capstan motor subcoil from point D. A pulsating current flows through Diode (D-704) from contact point C. This DC current + the pulsating current functions as a magnetic brake.

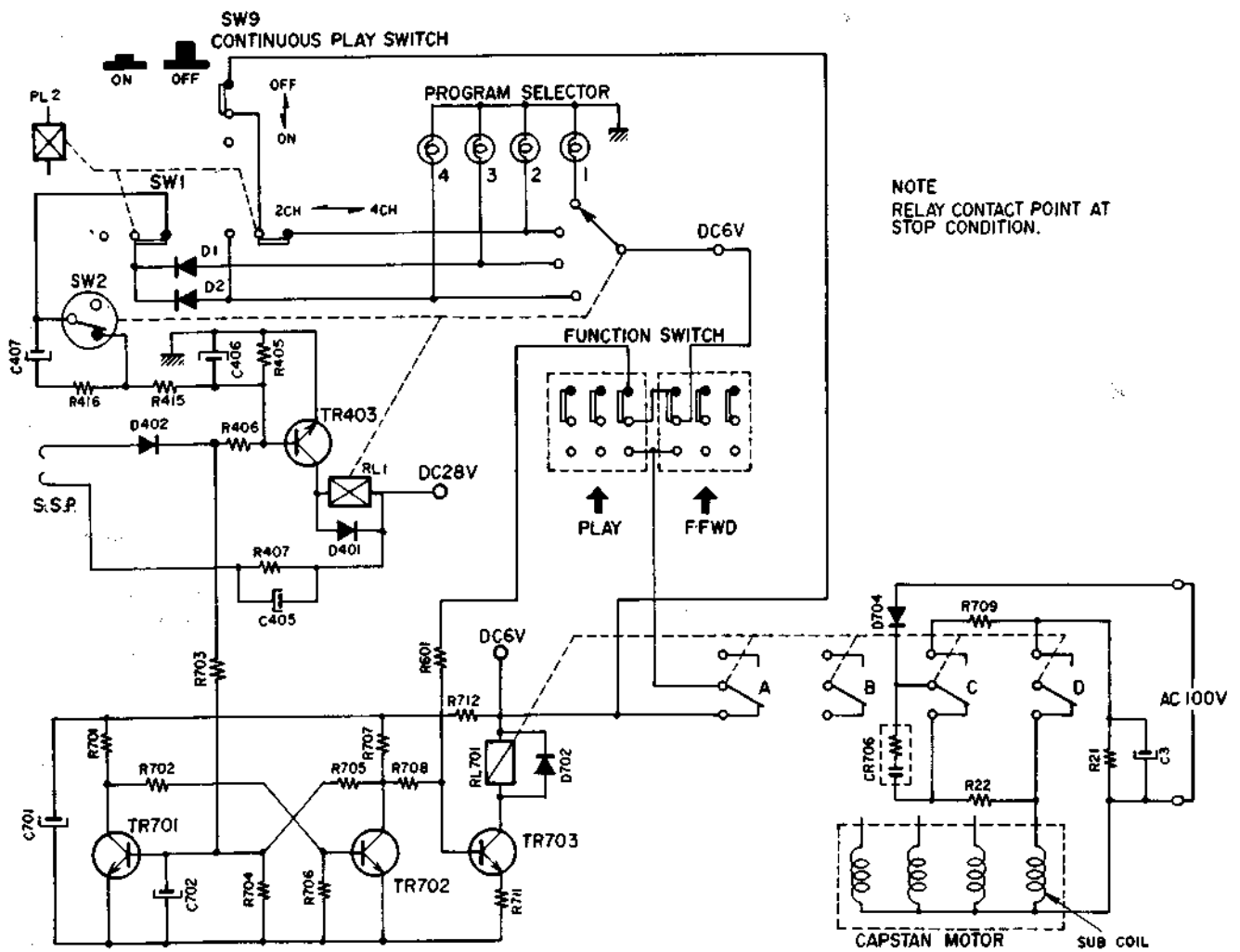
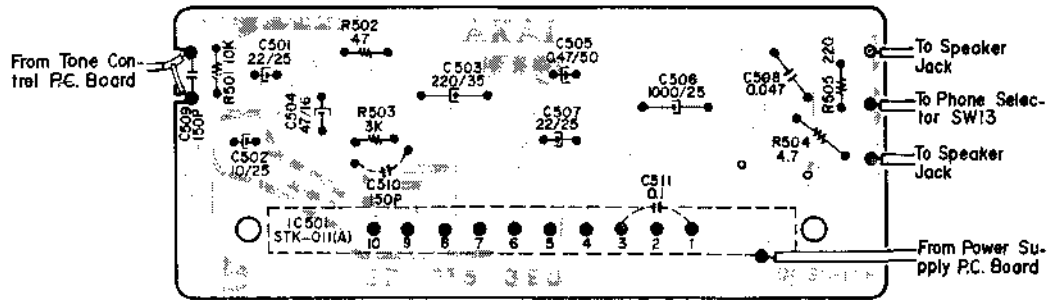

Fig. 14

- SW1 ... 2ch, 4ch selector (operates together with PL2)  
PL2 operates by means of stereo selector switch.
- SW2 ... Contact point is open only when PL1 is turned "ON".
- SW9 ... Continuous Play Switch.
- PL1 ... Program Selector Solenoid.
- PL2 ... Solenoid for 2ch, 4ch changeover Switch.
- RL701 ... STOP, PLAY, F. FWD Relay.



**POWER AMP. P.C. BOARD (ED-515)**



**OSCILLATOR P.C. BOARD (ED-B505)**

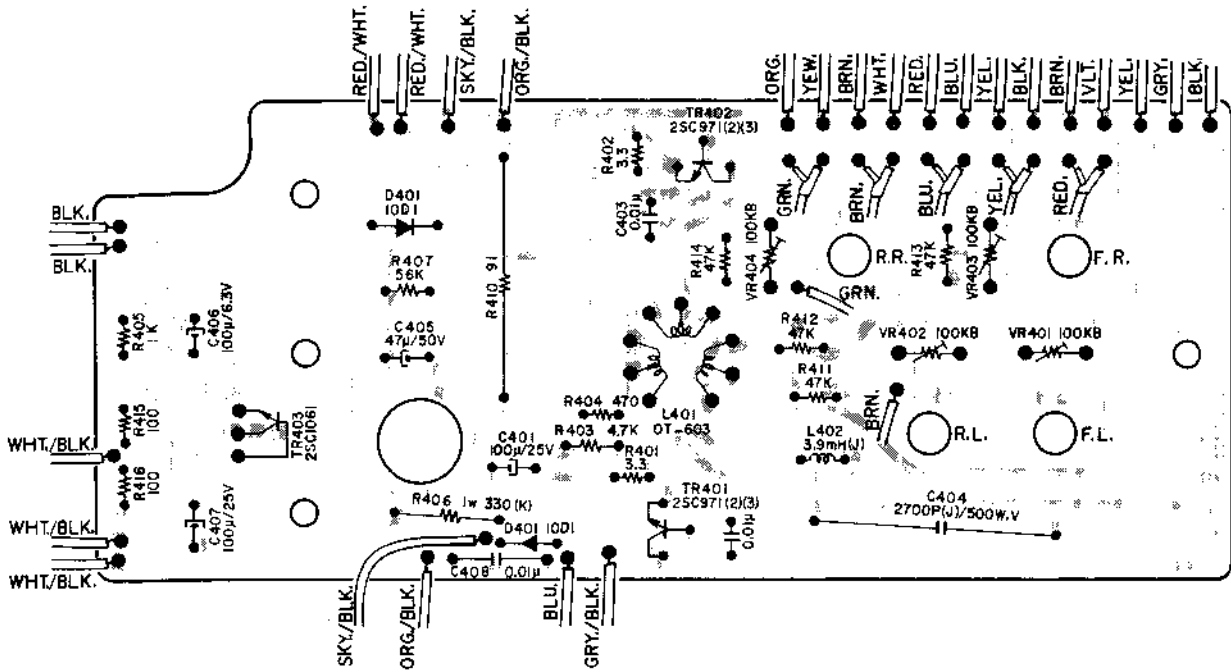

**MUTE P.C. BOARD (ED-B509)**

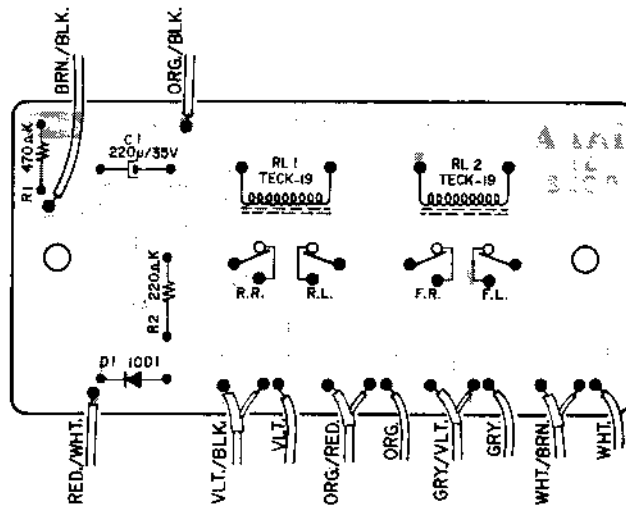

**RELAY P.C. BOARD (ED-522)**

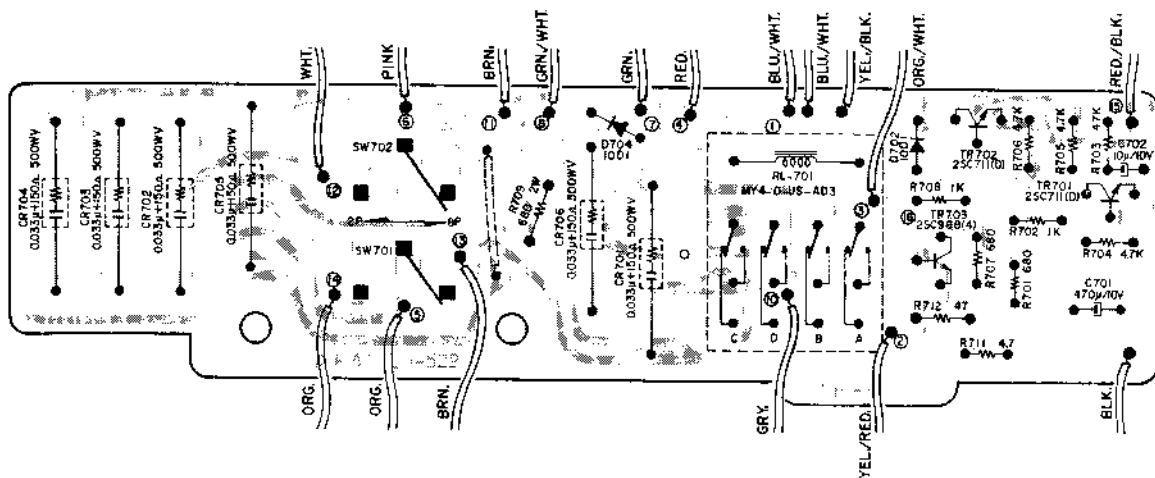

**RELAY P.C. BOARD (ED-522-2ED)**

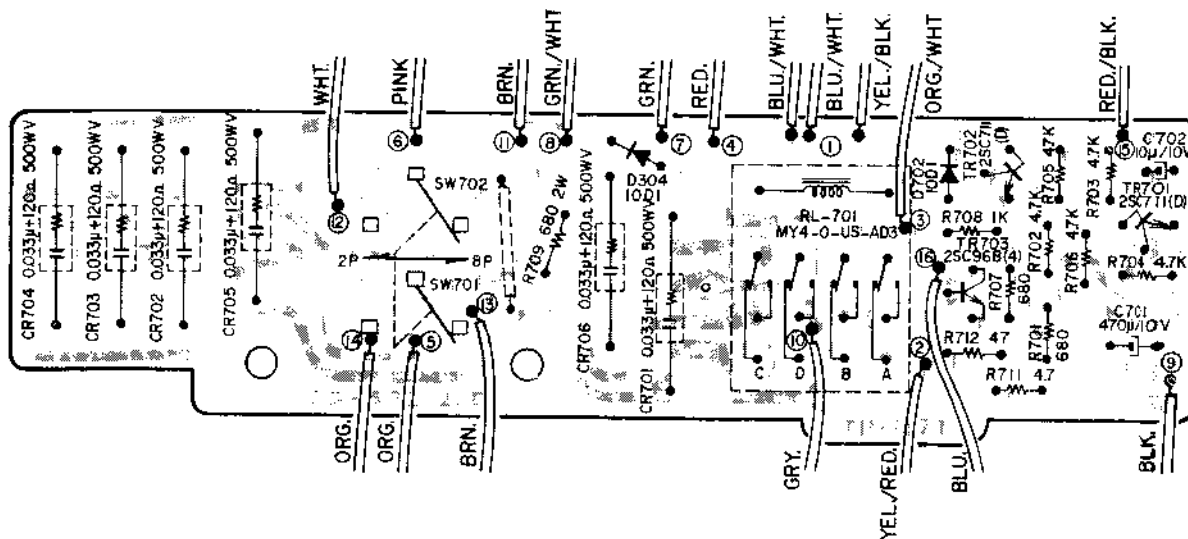

**SLIDE SWITCH P.C. BOARD (ED-B506)**

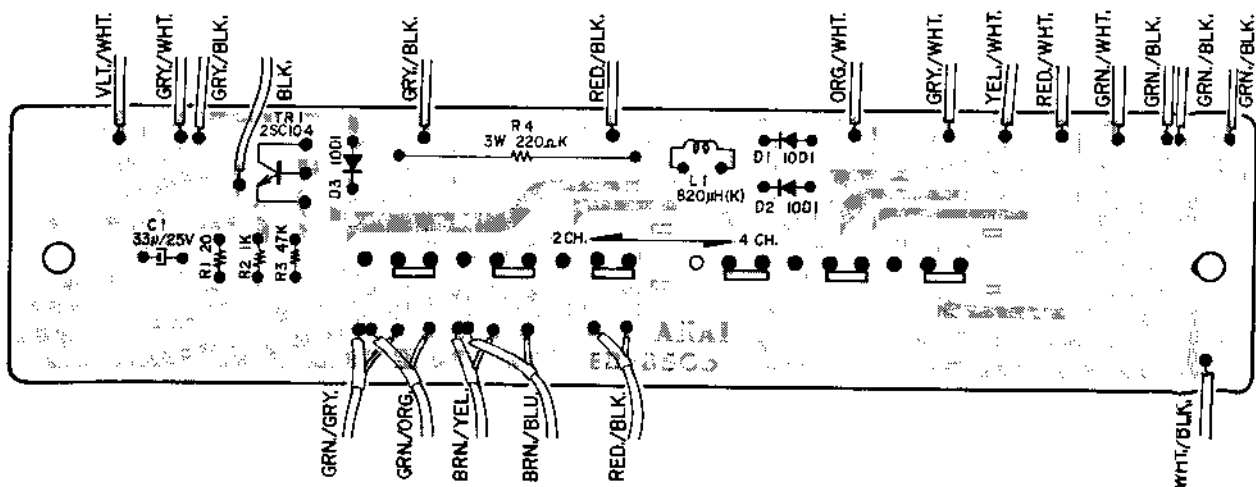



### TONE CONTROL P.C. BOARD (ED-B504)

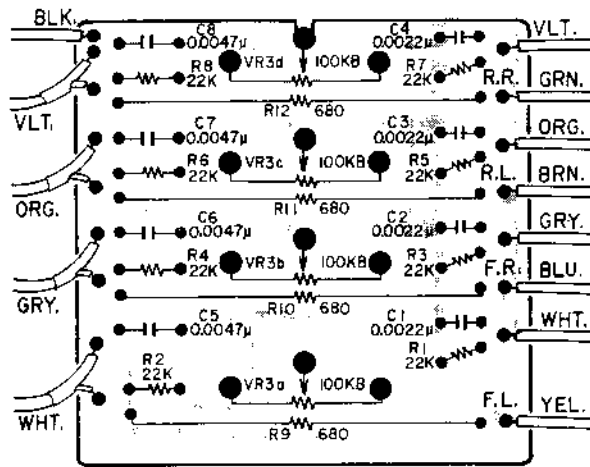

### FUNCTION SWITCH P.C. BOARD (ED-B214)

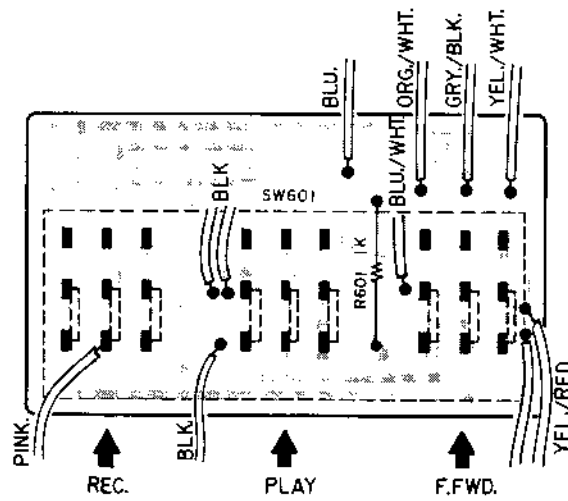

### POWER SOURCE P.C. BOARD

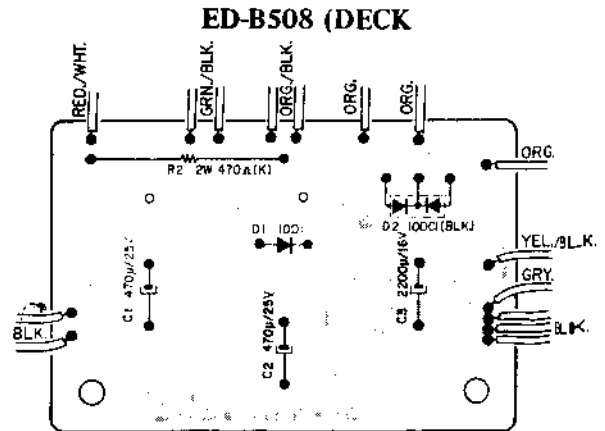
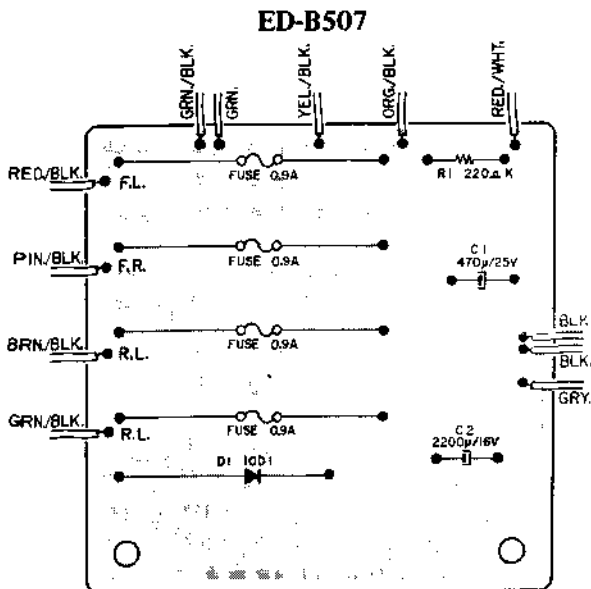

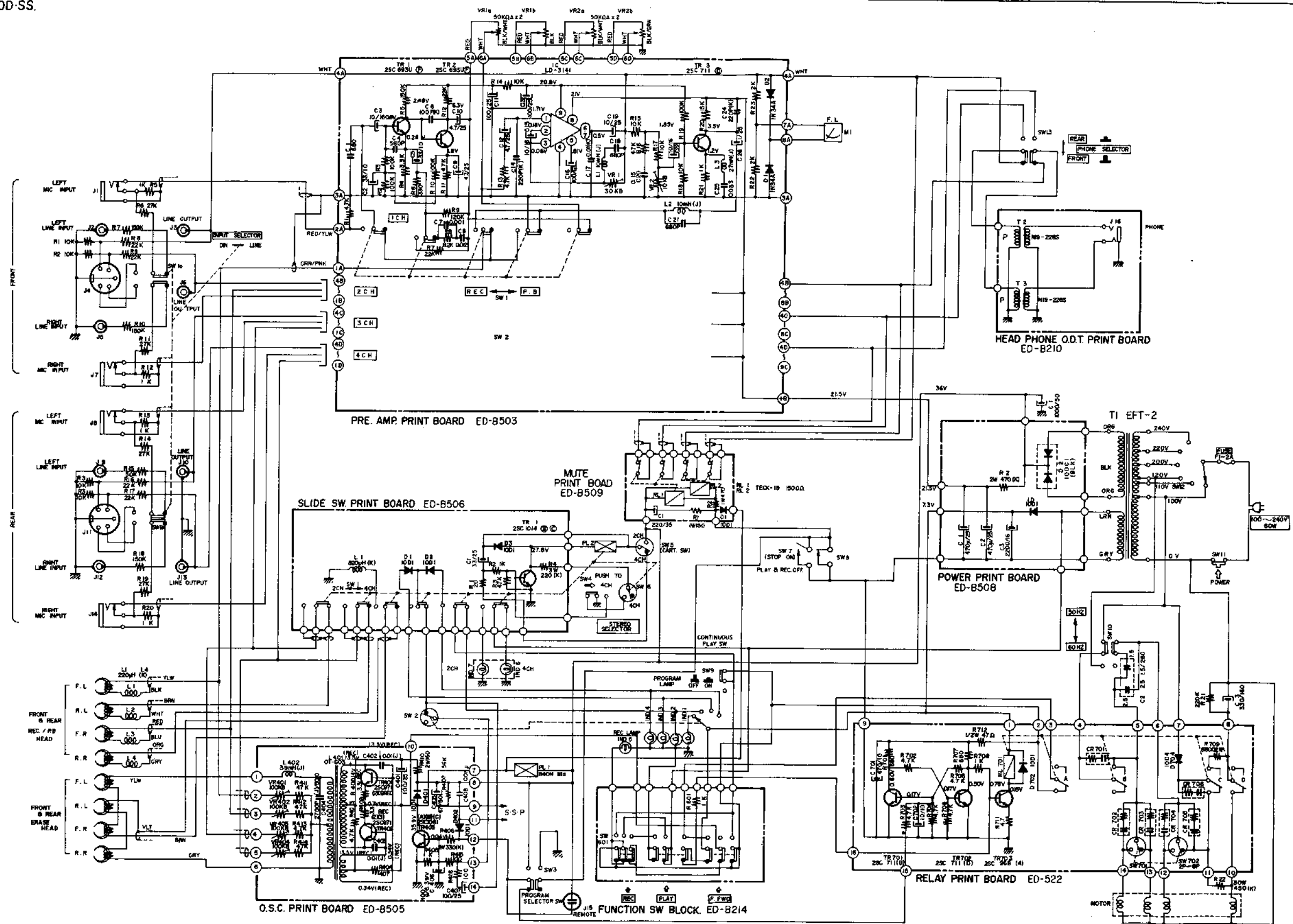

CR-80D-SS  
MECHANISM SCHEMATIC DIAGRAM 1422051A

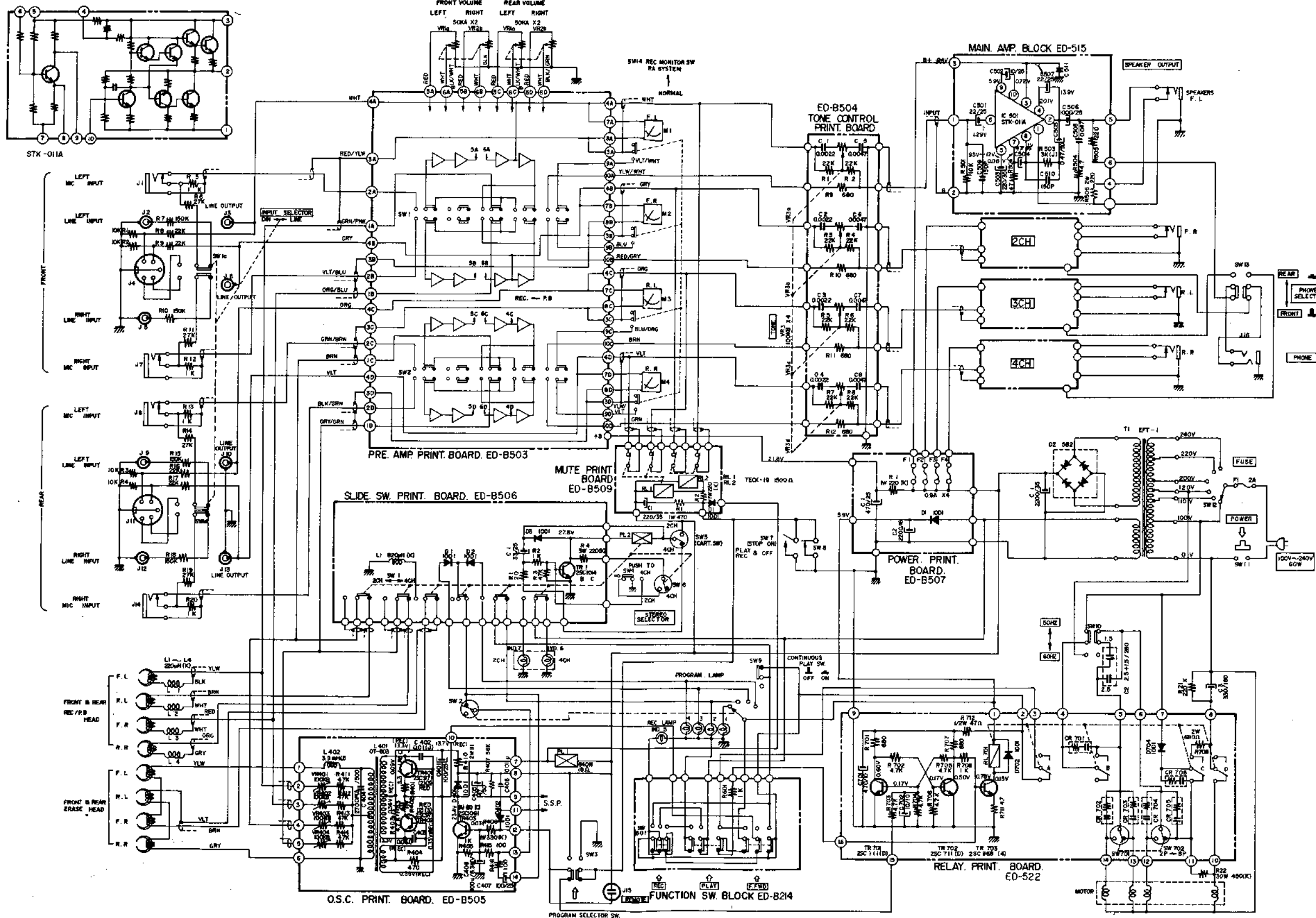

CR-80-SS  
MECHANISM SCHEMATIC DIAGRAM 1422050A