

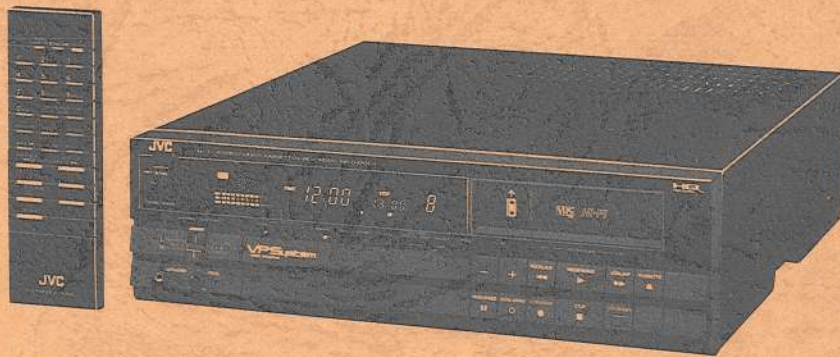
JVC

SERVICE MANUAL

Hi-Fi STEREO VIDEO CASSETTE RECORDER VHS

HR-D470E/EG/EK

HQ
High Quality



SPECIFICATIONS

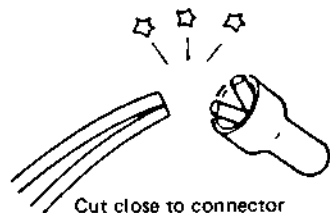
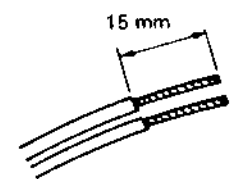
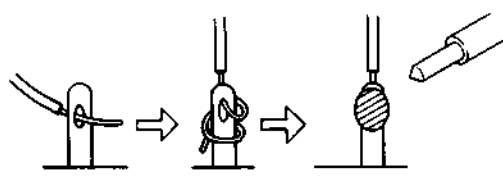
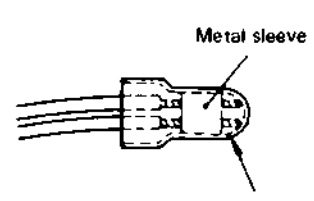
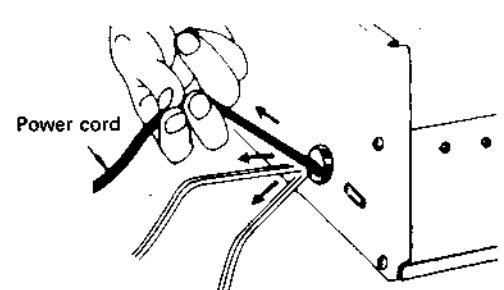
Format	: VHS PAL standard with Hi-Fi audio	Output level	: AUDIO/VIDEO socket (21-pin Peri connector): -3.8 dBs (CENELEC standard), high impedance load AUDIO AUSG. connector (RCA x 2): -6 dBs, high impedance load
Video recording system	: Rotary two-head helical scan system	Output impedance	: Less than 1 k-ohm, unbalanced
Hi-Fi audio recording system	: Deep-layer recording system conforming to stereo Hi-Fi VHS standard	Signal-to-noise ratio	: More than 40 dB
No. of audio channels	: 2 Hi-Fi audio channels 1 normal audio channel	Frequency range	: 70 Hz to 10,000 Hz
Video signal system	: PAL colour and CCIR monochrome signals, 625 lines	Hi-Fi audio	
Tape width	: 12.65 mm	Frequency response	: 20 Hz – 20,000 Hz
Tape speed (SP)	: 23.39 mm/sec	Dynamic range	: More than 80 dB
(LP)	: 11.70 mm/sec (Hi-Fi audio only)	Wow and flutter	: Less than 0.005 % WRMS
Maximum recording time (SP)	: 240 min. with E-240 video cassette	TV tuner/RF section	
(LP)	: 480 min. with E-240 video cassette (Hi-Fi audio only)	Channel storage capacity	: 32 channels
Temperature		Aerial input	: VHF 47 – 89 MHz, 104 – 300 MHz, 302 – 470 MHz UHF 470 – 862 MHz
Operating	: 5°C to 40°C	Aerial output	: UHF channels 32 – 40 (Adjustable)
Storage	: -20°C to 60°C	Digital clock/timer	
Power requirement	: 220 V~, 50/60 Hz	Clock display	: 24-hour fluorescent digital display with day and date indication
Power consumption	: 37 W	Reference frequency	: Quartz controlled
Video		Start time setting	: Within one year
Input	: 0.5 to 2.0 V _{p-p} , 75 ohms, unbalanced	Programming capacity	: 8 programmes
Output	: 1.0 V _{p-p} , 75 ohms, unbalanced		
Signal-to-noise ratio	: 43 dB (Rohde & Schwarz noise meter) with BILDSCHÄRFTE control at centre position	Dimensions	: 340 mm(W) x 105 mm(H) x 380 mm(D)
Horizontal resolution	: 250 lines with BILDSCHÄRFTE control at centre position	Weight	: 7.7 kg
Audio		Provided accessories	: Aerial cable, Cassette tape, Infrared remote control, "R03"-size battery x 2, Audio cable (RCA-RCA),
Input	: AUDIO/VIDEO socket (21-pin Peri connector): -3.8 dBs (CENELEC standard), 10 k-ohms, unbalanced AUDIO EING. connector (RCA x 2): -20 dBs, 50 k-ohms, unbalanced		

*Specifications shown are for SP mode unless otherwise specified.
Design and specifications subject to change without notice.*

Important Safety Precautions

Prior to shipment from the factory, JVC products are strictly inspected to conform with the recognized product safety and electrical codes of the countries in which they are to be sold. However, in order to maintain such compliance, it is equally important to implement the following precautions when a set is being serviced.

● Precautions during Servicing

<p>1. Locations requiring special caution are denoted by labels and inscriptions on the cabinet, chassis and certain parts of the product. When performing service, be sure to read and comply with these and other cautionary notices appearing in the operation and service manuals.</p>	<p>10. Products using cathode ray tubes (CRTs) In regard to such products, the cathode ray tubes themselves, the high voltage circuits, and related circuits are specified for compliance with recognized codes pertaining to X-ray emission. Consequently, when servicing these products, replace the cathode ray tubes and other parts with only the specified parts. Under no circumstances attempt to modify these circuits. Unauthorized modification can increase the high voltage value and cause X-ray emission from the cathode ray tube.</p>
<p>2. Parts identified by the \triangle symbol and shaded (■) parts are critical for safety. Replace only with specified part numbers. Note: Parts in this category also include those specified to comply with X-ray emission standards for products using cathode ray tubes and those specified for compliance with various regulations regarding spurious radiation emission.</p>	<p>11. Crimp type wire connector In such cases as when replacing the power transformer in sets where the connections between the power cord and power transformer primary lead wires are performed using crimp type connectors, if replacing the connectors is unavoidable, in order to prevent safety hazards, perform carefully and precisely according to the following steps.</p> <ol style="list-style-type: none"> 1) Connector part number : E03830-001 2) Required tool : Connector crimping tool of the proper type which will not damage insulated parts. 3) Replacement procedure <ol style="list-style-type: none"> (1) Remove the old connector by cutting the wires at a point close to the connector. <p>Important : Do not reuse a connector (discard it).</p>
<p>3. Use specified internal wiring. Note especially:</p> <ol style="list-style-type: none"> 1) Wires covered with PVC tubing 2) Double insulated wires 3) High voltage leads 	 <p>Cut close to connector</p> <p>Fig. 3</p> <p>(2) Strip about 15 mm of the insulation from the ends of the wires. If the wires are stranded, twist the strands to avoid frayed conductors.</p>
<p>4. Use specified insulating materials for hazardous live parts. Note especially:</p> <ol style="list-style-type: none"> 1) Insulation Tape 2) PVC tubing 3) Spacers 4) Insulation sheets for transistors 	 <p>15 mm</p> <p>Fig. 4</p>
<p>5. When replacing AC primary side components (transformers, power cords, noise blocking capacitors, etc.) wrap ends of wires securely about the terminals before soldering.</p>  <p>Fig. 1</p>	<p>(3) Align the lengths of the wires to be connected. Insert the wires fully into the connector.</p>  <p>Metal sleeve</p> <p>Connector</p> <p>Fig. 5</p>
<p>6. Observe that wires do not contact heat producing parts (heat-sinks, oxide metal film resistors, fusible resistors, etc.)</p>	<p>9. Also check areas surrounding repaired locations.</p>
<p>7. Check that replaced wires do not contact sharp edged or pointed parts.</p>	
<p>8. When a power cord has been replaced, check that 10–15 kg of force in any direction will not loosen it.</p>  <p>Power cord</p> <p>Fig. 2</p>	

(4) As shown in Fig. 6, use the crimping tool to crimp the metal sleeve at the center position. Be sure to crimp fully to the complete closure of the tool.

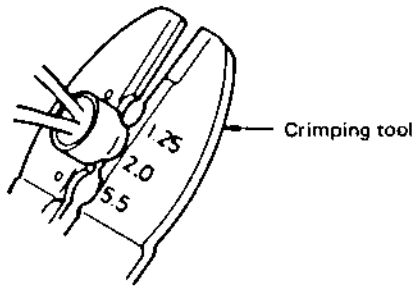


Fig. 6

(5) Check the four points noted in Fig. 7.

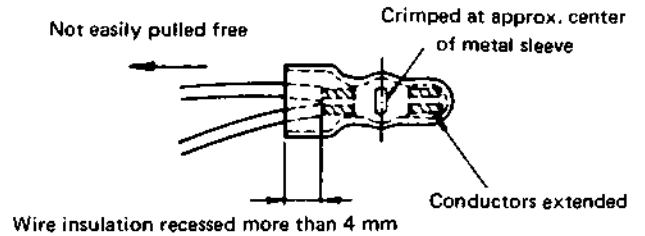


Fig. 7

● Safety Check after Servicing

Examine the area surrounding the repaired location for damage or deterioration. Observe that screws, parts and wires have been returned to original positions. Afterwards, perform the following tests and confirm the specified values in order to verify compliance with safety standards.

1. Insulation resistance test

Confirm the specified insulation resistance or greater between power cord plug prongs and externally exposed parts of the set (RF terminals, antenna terminals, video and audio input and output terminals, microphone jacks, earphone jacks, etc.). See table below.

2. Dielectric strength test

Confirm specified dielectric strength or greater between power cord plug prongs and exposed accessible parts of the set (RF terminals, antenna terminals, video and audio input and output terminals, microphone jacks, earphone jacks, etc.). See table below.

3. Clearance distance

When replacing primary circuit components, confirm specified clearance distance (d), (d') between soldered terminals, and between terminals and surrounding metallic parts. See table below.

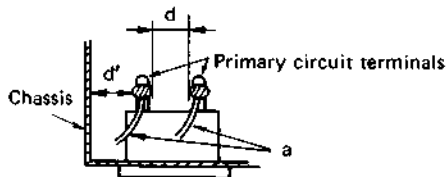


Fig. 8

4. Leakage current test

Confirm specified or lower leakage current between B (earth ground, power cord plug prongs) and externally exposed accessible parts (RF terminals, antenna terminals, video and audio input and output terminals, microphone jacks, earphone jacks, etc.).

Measuring Method: (Power ON)

Insert load Z between B (earth ground, power cord plug prongs) and exposed accessible parts. Use an AC voltmeter to measure across both terminals of load Z. See figure and following table.

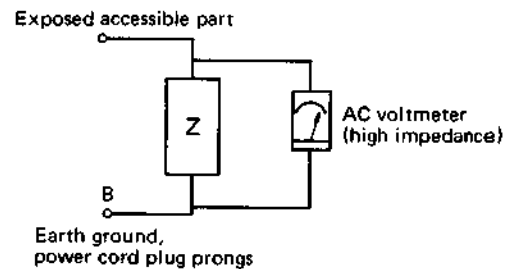


Fig. 9

AC Line Voltage	Region	Insulation Resistance	Dielectric Strength	Clearance Distance (d), (d')
100 V	Japan	$\geq 1 \text{ m}\Omega/500 \text{ V DC}$	1 kV 1 minute	$\geq 3 \text{ mm}$
110 to 130 V	USA & Canada	—	900 V 1 minute	$\geq 3.2 \text{ mm}$
*110 to 130 V 200 to 240 V	Europe Australia	$\geq 10 \text{ m}\Omega/500 \text{ V DC}$	4 kV 1 minute	$\geq 6 \text{ mm (d)}$ $\geq 8 \text{ mm (d')}$ (a: Power cord)

*Class II model only.

Table 1 Ratings for selected areas

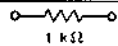
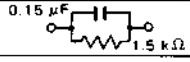
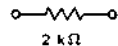
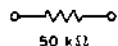
AC Line Voltage	Region	Load Z	Leakage Current (i)	Earth Ground (b) to:
100 V	Japan	 1 k Ω	$i \leq 1 \text{ mA rms}$	Exposed accessible parts
110 to 130 V	USA & Canada	 0.15 μF 1.5 k Ω	$i \leq 0.5 \text{ mA rms}$	Exposed accessible parts
110 to 130 V 220 to 240 V	Europe Australia	 2 k Ω	$i \leq 0.7 \text{ mA peak}$ $i \leq 2 \text{ mA dc}$	Antenna earth terminals
		 50 k Ω	$i \leq 0.7 \text{ mA peak}$ $i \leq 2 \text{ mA dc}$	Other terminals

Table 2 Leakage current ratings for selected areas

Note: This table is unofficial and for reference only. Be sure to confirm the precise values for your particular country and locality.

INSTRUCTIONS

Thank you for purchasing the JVC HR-D470EG Hi-Fi Stereo Video Cassette Recorder. Before use, read this instruction booklet carefully for obtaining the best results from your new unit.

CONTENTS

Features	32	Recording a TV programme while recording an independent audio source	48
Precautions	33	Using the HR-D470EG as an audio deck	49
Controls, indicators and connectors	34	Instant recording	50
Connections	37	Automatic VPS or timer recording	51
Video channel setting	38	Music Scan and Record Mute functions	55
Operating the built-in tuner	39	Counter Go-To function	56
Clock setting	41	Counter memory and Counter/Remain functions	57
Information on the HR-D470EG's audio system	42	Recording with a video camera	57
Loading and unloading a cassette	45	Adjust your TV receiver when	58
Playing back a video cassette	46	Head cleaning	58
Basic operation for recording TV programmes	47	In case of difficulty	59
Recording a TV programme while watching another	48	Specifications	61
Recording stereo TV programmes	48		
Recording bilingual TV programmes	48		
Recording FM simulcast TV programmes	48		

SAFETY PRECAUTIONS

The rating plate and the safety caution are on the rear of the unit.

WARNING - DANGEROUS VOLTAGE INSIDE

WARNING: TO PREVENT FIRE OR SHOCK HAZARD, DO NOT EXPOSE THIS UNIT TO RAIN OR MOISTURE.

IMPORTANT (In the United Kingdom) Mains Supply (240 V~, 50 Hz only)

IMPORTANT

Do not make any connection to the Larger Terminal coded E or Green. The wires in the mains lead are coloured in accordance with following code:



If these colours do not correspond with the terminal identifications of your plug, connect as follows:
Blue wire to terminal coded N (Neutral) or coloured Black.
Brown wire to terminal coded L (Live) or coloured Red.
If in doubt - consult a competent electrician.

Note

We recommend that you should disconnect the AC cord from the outlet.

CAUTION

- Disconnect the mains plug from the supply socket when not in use.
- When you are not using the HR-D470EG for a long period of time, it is recommended that you disconnect the power cord from the AC outlet.
- Dangerous voltage inside. Refer internal servicing to qualified service personnel. To prevent electric shock or fire hazard, remove the power cord from the AC outlet prior to connecting or disconnecting any signal lead or aerial.



- Only cassettes marked "VHS" can be used with this video cassette recorder.
- HQ VHS is compatible with existing VHS equipment.

FOR YOUR SAFETY (in Australia) Install any external aerial to AS 1417.1

Omkopplaren **BETRIEB** på denna apparat är sekundärt kopplad och skiljer inte apparaten från nätet i läge **BETRIEB OFF**.

The **BETRIEB** button does not completely shut off mains power from the unit, but switches operating current on and off.

BEMÆRK: I stilling OFF er apparatet stadig forbundet med lysnettet. Hvis det ønskes fuldstændig afbrudt skal netledningen trækkes ud.

This equipment has been produced to comply with Directive number 82/499/EEC (82/499/CEE).

FEATURES

High-quality pictures

- **HQ (High Quality) System technologies** for superlative VHS pictures with a Detail Enhancer and a higher white clip level.

High-quality sound

- **Conforms to the Hi-Fi VHS standard** for superlative stereo sound with a dynamic range of more than 80 dB.
- **New audio switching noise reduction system** for cleaner-than-ever high-fidelity sound reproduction.
- **Hi-Fi audio Long Play mode** allows up to 8 hours of continuous Hi-Fi stereo sound recording and playback with a single cassette.
- **Peak-hold audio level indicators/Hi-Fi Tracking meter.**
- **Hi-Fi recording level controls.**

Tuner features

- **PLL frequency synthesized wide-band cable tuner** with 32-channel storage capacity.
- **Retuned to European television broadcast frequencies:** VHF, UHF and cable channels including those of hyper band.
- **Sound Multiplex capability** for recording stereo and bilingual broadcasts.
- **10-Key random-access channel selection** and up/down scan tuning.
- **Compatible with VPS (Video Programme System)** with built-in VPS decoder.

Automatic functions

- **Music Scan;** up to 9 musical selections can be scanned in either direction.
- **Record mute function;** a 5-second blank can be inserted on the normal audio track between musical selections for automatic scanning.
- **Counter go-to function** for direct access to any specified point on the tape.
- **Fully automated playback procedure:** insert a cassette (with safety tab removed), and playback will start automatically.
- **Memory play function** for automatic start of playback after rewind to the beginning of the tape or rewind/fast forward to the counter reading of "0000".
- **Automatic backspace editing.**
- **Auto-power-on convenience.**
- **Automatic power on/off for cassette ejection.**
- **Automatic rewind at the end of tape.**

Other value features

- **New, contemporary styling** in midi-component size (34 cm wide) with motorised slot-loading cassette system.
- **1-Year/8-Event programmable timer with 10-key programming.**
- **On-screen record-pause mode display;** a white bar is displayed on the TV screen while in the record-pause mode.
- **Multi-function infrared remote control:** timer programming, music scan, direct counter go-to function, audio monitor selection, 10-key random-access channel selection, and more.
- **Switchable AC outlet** to timer-control a connected source component.
- **FM simulcast recording;** also allows independent TV and audio programming on the same cassette.
- **60-Minute memory backup** for clock and timer settings.
- **Instant recording function** with auto shut-off.
- **Shuttle Search** at 9 times normal speed.
- **Picture sharpness control.**
- **Counter search function.**
- **Comprehensive fluorescent display** with symbolic mode indicators.
- **Remaining tape time indicator** functioning during Record, Play, Fast Forward and Rewind.
- **Headphone jack** with level control.

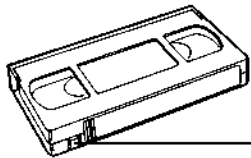
PRECAUTIONS

Handling and storage

- Avoid using the recorder under the following conditions:
 - extremely hot, cold or humid places,
 - dusty places,
 - near appliances generating strong magnetic fields,
 - places subject to vibrations, and
 - poorly ventilated places.
- Be careful of moisture condensation. Avoid using the recorder immediately after moving from a cold place to a warm place or soon after heating a room which was cold. The water vapour in warm air will condense on the still-cold video head drum and tape guides and may cause damage to the tape and the recorder.
- Handle the recorder carefully.
 - Do not block the ventilation openings.
 - Do not place anything heavy on the recorder.
 - Do not place anything which might spill and cause trouble on the top cover of the recorder.
 - Use in horizontal (flat) position only.
- In case of transportation,
 - Avoid violent shocks to the recorder during packing and transportation.
 - Before packing, be sure to remove the cassette from the recorder.

Video cassettes

- This recorder employs VHS-type cassettes only. E-240 for 4 hours, E-180 for 3 hours, E-120 for 2 hours, E-90 for 1 hour and 30 minutes, E-60 for 1 hour and E-30 for 30 minutes of recording. The recording time of each cassette can be doubled if you use the LP (Long Play) mode for recording Hi-Fi audio only.
- Video cassettes are equipped with a safety tab to prevent accidental erasure. When the tab is removed, recording cannot be performed. If you wish to record on a cassette whose tab has already been removed, use adhesive tape to block the hole.



Safety tab

- Avoid exposing the cassettes to direct sunlight. Keep them away from heaters.
- Avoid extreme humidity, violent vibrations or shocks, strong magnetic fields (near a motor, transformer or magnet) and dusty places.
- Place the cassettes in cassette cases and position vertically.

Moisture condensation

- If you pour a cold liquid into a glass, water vapour in the air will condense on the surface of the glass. This is called moisture condensation.
- Moisture condensation on the head drum, one of the most crucial parts of the video recorder, will cause damage to the tape.
- Moisture in the air will condense on the recorder when you move it from a cold place to a warm place, after heating a cold room or under extremely humid conditions.
- This recorder is equipped with a moisture condensation prevention circuit which automatically heats the head drum according to the ambient temperature. This circuit operates when the unit is plugged into an AC outlet.
- The moisture condensation prevention circuit consumes only a slight amount of power. However, if for some reason you are not using the recorder for a long period of time, it is advisable to remove the power cord from the AC outlet.
- Since the moisture condensation prevention circuit cannot evaporate existing moisture condensation immediately after the power cord has been plugged into the AC outlet, you must allow for a few hours if the recorder is to be used in such areas as would occasion moisture condensation.

Operation

- When a cassette is loaded, the power is switched on automatically.
- The cassette can be unloaded even when the power is off. Pressing the KASSETTE button turns the power on and, after ejection of the cassette, shuts it off automatically in this case.
- As long as the SCHALTUHR button is engaged with the TIMER indicator lit, the BETRIEB and KASSETTE buttons have no effect and unloading of a cassette is not possible. If a cassette has not yet been inserted, simply insert a cassette; the power will be switched on to load the cassette properly and, after completion of automatic loading, the Timer Recording Standby mode will be engaged with power off.

Remote control unit

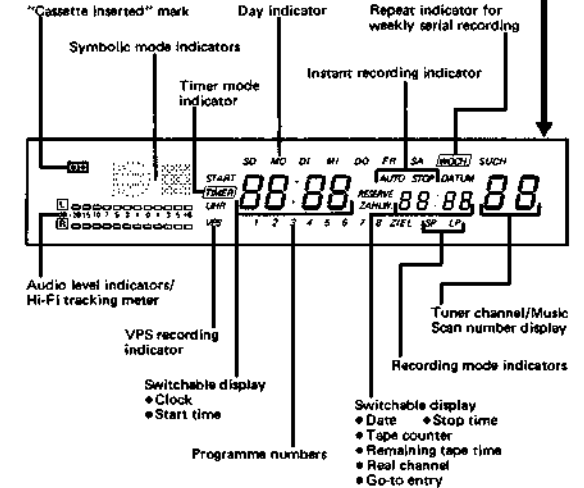
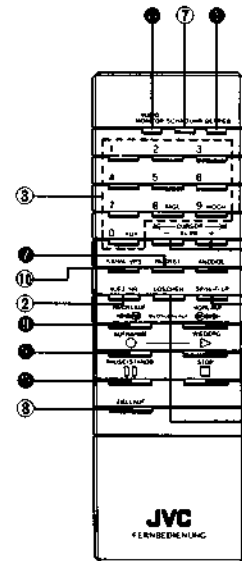
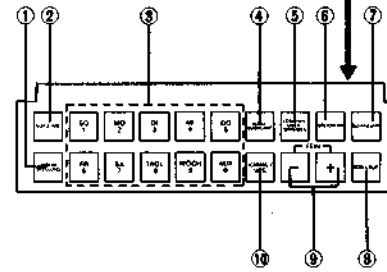
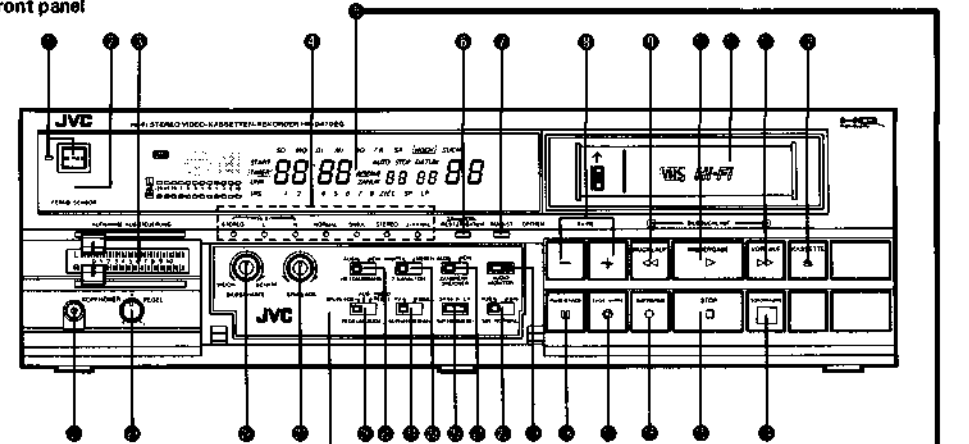
- Avoid violent shocks, especially take care not to drop the unit.
- Take care not to allow liquid to spill into the unit.
- Do not place heavy objects on the unit.
- Avoid leaving the unit in places subject to direct sunlight or extremely high temperatures.

WARNING

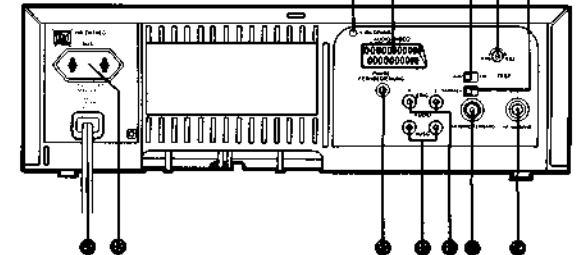
1. This recorder can also receive colour television signals in East Germany (DDR) for recording and playback.
2. Recordings made of DDR television signals produce monochrome pictures if played back on another video recorder of PAL or SECAM standard.
3. SECAM prerecorded cassettes or recordings made with a SECAM video recorder produce monochrome pictures when played back with this recorder.
4. This recorder cannot be used in France. Use a SECAM recorder to record French SECAM signals.

CONTROLS, INDICATORS AND CONNECTORS

Front panel



Rear panel



- ① Operate button (BETRIEB) with LED indicator
Loading a cassette also turns the power on. See page 45.
- ② Infrared beam receiving window (FERNB. SENSOR)
- ③ Hi-Fi audio recording level controls (AUFNAHME-AUSSTEUERUNG)
See page 43.

④ LED indicators

STEREO: Lights when the AUDIO MONITOR button is pressed to select the stereo sound for listening.

L: Lights when the AUDIO MONITOR button is pressed to select the hi-fi left channel sound for listening.

R: Lights when the AUDIO MONITOR button is pressed to select the hi-fi right channel sound for listening.

NORMAL: Lights when the AUDIO MONITOR button is pressed to select the normal soundtrack for listening.

SIMUL: Lights when the AUFNAHME-WAHL switch is set to SIMUL.

STEREO: Lights when a stereo programme is being received.

Bilingual: Lights when a bilingual programme is being (2-KANAL) received.

⑤ Fluorescent display section

The symbolic mode indicator illuminates to give quick, easy visual reference of the operating mode. Combinations of 5 different symbols indicate 12 operating modes:

PLAY:		REWIND:	
STILL:		FAST FORWARD:	
RECORD:		REVERSE SHUTTLE SEARCH:	
RECORD PAUSE:		FORWARD SHUTTLE SEARCH:	
GO-TO PLAY:		MEMORY PLAY:	
REC MUTE:		REC MUTE - REC PAUSE:	

⑥ Counter/Remain/Date button (ZÄHLWERK/RESTZT./DATUM) (ANZEIGE)

Press to switch the middle 4-digit display among tape counter, remaining tape time and date. Can also be used to change the entire display from the Timer Set mode to the Clock mode. (See page 57.)

⑦ Reset button (RÜCKST.)

⑧ TV programme +/- buttons (TV PR. +/-)

Press and hold the "+" or "-" button to quickly review channels. See page 39.

These buttons can also be used as cursor keys in the clock and timer setting modes. See page 53.

⑨ Rewind/Shuttle search button (RÜCKLAUF/BILD-SUCHLAUF)

To rewind the tape, press this button while in the Stop mode. To view the speeded-up picture or scan musical selections in the reverse direction, press this button while in the Play mode.

⑩ Play button (WIEDERGABE)

Press to play back the tape or cancel the Pause/Still or Search mode. Also press this button together with the AUFNAHME button for recording.

⑪ Fast forward/Shuttle search button (VORLAUF/BILDSUCHLAUF)

To fast forward the tape, press this button while in the Stop mode. To view the speeded-up picture or scan musical selections in the forward direction, press this button while in the Play mode.

⑫ Cassette eject button (KASSETTE)

⑬ Cassette loading slot

Insert a VHS video cassette. See page 33.

⑭ Instant recording button (SOFORTAUFN.)

Use this button to start recording instantly and stop automatically after a predetermined time. See page 50.

⑮ STOP button

To stop the tape.

⑯ Record button (AUFNAHME)

Press together with the WIEDERGABE button for video and audio recording.

⑰ Record mute button (SUCHL. MARKE)

To make non-recorded sections (about 5 seconds) when recording music tapes. See page 55.

⑱ Pause/Still button (PAUSE/STANDB.)

Press to stop the tape temporarily to avoid recording of unwanted material or to view a still picture. The still picture can be advanced each time this button is pressed.

⑲ AUDIO MONITOR button

Each time the button is pressed, the soundtrack to be output changes and is indicated by one of the audio select indicators. See page 44.

⑳ MIX NORMAL switch

See page 44.

㉑ Counter memory button (ZÄHLWERK-SPEICHER)

See page 57.

㉒ Recording time (AUFNAHMEZEIT) (SP/Hi-Fi LP)

Normally set this button to the SP (Standard Play) mode ("SP" lights on the FDP) when recording. In the SP mode, both pictures and sound are recorded, allowing up to 4 hours of continuous recording with a single cassette (E-240).

When using the HR-D470EG as an audio deck, you can use the LP (Long Play) mode by pressing this button to obtain the LP indication on the FDP. In this mode, Hi-Fi audio recording is possible for up to 8 hours with a single cassette (E-240).

㉓ Tuner sound select switch (2-KANALTON)

Selects the desired soundtrack to be recorded on the normal audio track when recording bilingual TV programmes. Both soundtracks will be recorded on the hi-fi audio track with the main one on channel 1 and the sub soundtrack on channel 2.

Note:

Stereo programmes are recorded in stereo on the hi-fi audio track and in mono (mixed L + R) on the normal audio track regardless of the setting of this switch.

Main : To record the main soundtrack (local language).

Sub : To record the sub soundtrack (foreign language).

㉔ Input select switch (AUFNAHMEWAHL)

For selecting the recording input signal.

SIMUL: To record the video signal and normal audio signal from the built-in tuner and the hi-fi audio signal from the rear panel AUDIO EING. connectors. When recording FM simulcast TV programmes, use this position.

TV: To record signals coming from the built-in tuner.

㉕ AC online switch (NETZAUSGANG)

Off position : Power flows through the rear panel AC (AUS) outlet regardless of whether the recorder is on or off.

On position : Power flows only when the recorder is on. When used in combination with the built-in timer, this enables timer-controlled power supply for the connected equipment. See pages 36 and 37.

㉖ Level indicator switch (PEGELANZEIGE)

See page 43.

㉗ Tracking control (SPURLAGE)

See page 43 or 46.

㉘ Picture sharpness control (BILDSCHÄRFE)

Turn this knob clockwise to make the picture sharper. Turn counterclockwise to give the picture a softer tone. Effective only for playback pictures. (No effect for recording.)

㉙ Headphone level control (PEGEL)

Adjusts the level of audio output from the KOPFHÖRER jack.

㉚ Headphone jack (KOPFHÖRER)

Connect a set of headphones for monitoring or private listening.

㉛ Sub control panel

① Clock adjust button (UHREINSTELLUNG)

Press this button for clock setting. See page 41.

② Programme button (AUFZ. NR.)

Press this button when you want to preset the timer for unattended recording. See page 51.

③ Multi-purpose numeric keys

Clock setting: See page 41.

Channel selection: See page 39.

Timer programming: See page 51.

Music Scan: See page 55.

Counter Go-To: See page 56.

The "0" key also functions as the AUX mode select button. To record from a source connected to the rear panel AUDIO/VIDEO socket, obtain "0" in the channel display by pressing the "0" key.

④ Search button (AUTO-SUCHLAUF)

Press this button to initiate automatic scan tuning in the Real-channel mode. (See pages 39 and 40.)

⑤ Cancel/Skip button (LÖSCHEN/ÜBERSPRINGEN)

A dual-purpose switch. Use to clear the programmed data in the Timer Set mode or skip unnecessary channels in the Channel Set mode. The CANCEL button on the remote control unit only functions in the Timer Set mode. (See page 40 or 52.)

⑥ Store button (SPEICHERN)

Press to store necessary channels. (See page 40.)

⑦ Timer button (SCHALTUHR)

Press to engage the Timer Recording Standby mode after you have preset the timer for unattended recording. See page 51.

⑧ Go-to button (ZIELLAUF)

Press to engage the Counter Go-To mode. See page 56.

⑨ Fine (-/+) buttons (FEIN +/-)

To fine-tune to a certain station by shifting the frequency in either direction. (See page 40.)

⑩ Channel/VPS button (KANAL/VPS)

Press to engage the Real Channel mode (see page 39) or to engage the VPS recording standby mode (see page 53).

㉜ Pause remote control terminal (PAUSE FERNBEDIENUNG)

When using a JVC video camera, connect the remote control cable of the camera adapter to this terminal for the purpose of controlling the starting and stopping of the tape with the camera's start/stop switch.

㉝ Test signal switch (TEST)

Set to EIN when tuning your TV receiver for the video channel. A test signal in the form of two vertical white bars will be available.

㉞ RF converter frequency adjustment screw

See page 38.

㉟ Attenuator switch (ANT. SIGNAL)

Set to SCHWACH to receive broadcasts from distant stations. Set to STARK to receive broadcasts of high field strength. Use a screwdriver for setting this switch.

㊱ RF output connector (HF-AUSGANG)

Connect to the aerial connector of a TV receiver through the aerial cable (provided).

㊲ Antenna input connector (ANTENNEN-EINGANG)

Connect an aerial to this connector.

㊳ Audio input connectors (AUDIO EING.)

Connect an audio tape recorder or other audio sources for recording sound. The input from these connectors can be recorded on the hi-fi track when the AUFNAHMEWAHL switch is set to SIMUL.

㊴ Audio output connectors (AUDIO AUSG.)

Both hi-fi and normal audio signals can be obtained from these connectors. The output can be selected with the MIX NORMAL switch and the AUDIO MONITOR button.

㊵ AC outlet (GESCHALTET)

Connect the power cord of other audio or video equipment (such as an FM tuner) requiring less than 2 amperes of power.

This outlet is controlled by the NETZAUSGANG switch. When the NETZAUSGANG switch is set to AUS, this outlet supplies power (220 V~, 50/60 Hz) regardless of the BETRIEB switch setting as long as the power cord of the HR-D470EG is plugged in.

When the NETZAUSGANG switch is set to EIN, this outlet supplies power only when the recorder is on.

㊶ Power cord

Infrared remote control unit

The infrared remote control unit gives you full operation control from your viewing position. The maximum operating distance is about 8 m.

Buttons with the same reference numbers as the recorder's buttons have the same functions.

Note: The numeric keys on the remote control do not function for clock setting.

Rear panel

㉟ V. lock adjustment screw (V-BILDFANG)

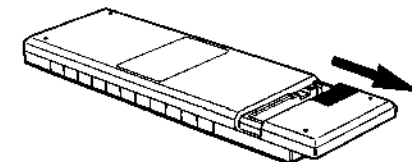
When operating in the Still mode, adjust this screw to eliminate any vertical vibration of the picture, by using a screwdriver.

㊱ AUDIO/VIDEO socket

A 21-pin standardised audio/video input/output socket for the connection to a stereo TV equipped with the same type of socket. The input from this socket can be recorded in the AUX mode with "0" in the channel display. The audio output can be selected with the MIX NORMAL switch and the AUDIO MONITOR button.

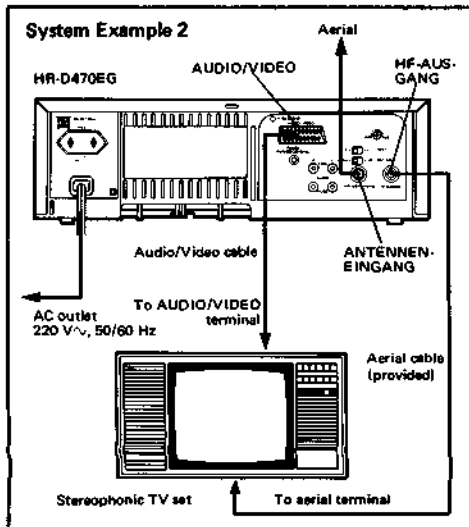
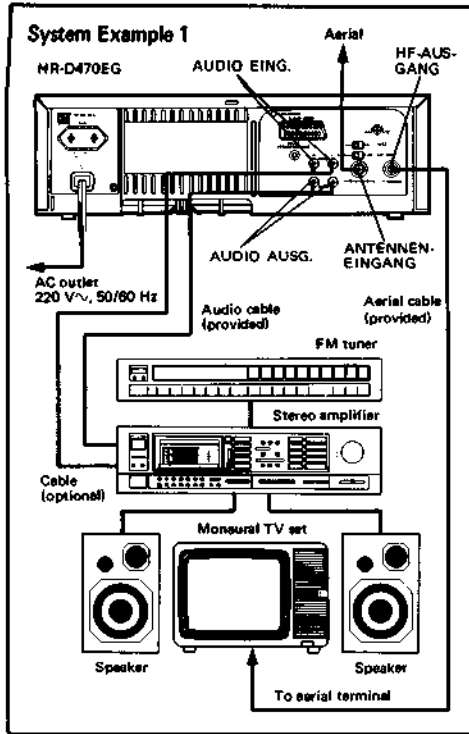
Installing the batteries

1. Slide the battery compartment cover on the rear of the unit in the direction of the arrow (▶).



2. Insert 2 "R03" -size batteries (provided) in the correct directions into the battery compartment.
3. Replace the cover.

CONNECTIONS



Procedure

1. Remove the aerial cable from the TV receiver and reconnect to the HR-D470EG.
2. Connect the HR-D470EG to the TV receiver using the aerial cable (provided).
3. Connect the AUDIO EING. L and R connectors of the HR-D470EG to the recording output terminals of the amplifier. (Exactly as one hooks up an audio cassette deck.)
4. Connect the AUDIO AUSG. L and R connectors of the HR-D470EG to the AUX or TAPE MONITOR input terminals of the amplifier.

Notes:

- Observe L and R when connecting the audio input and output connectors of the HR-D470EG to a stereo amplifier.
- If stereo or bilingual TV broadcasts are receivable in your area, this recorder can record them independently of the TV set and play them back through the connected audio system.
- When listening to sound from the connected stereo system, turn down completely the sound volume of the TV receiver.
- Listening to stereophonic sound is also possible using stereo headphones connected to the front panel KOPFHÖRER jack.
- With this setup, you can enjoy prerecorded Hi-Fi VHS video tapes in hi-fi stereo while viewing them on a regular TV receiver, and also you can record FM simulcast television programmes with hi-fi audio accompaniment. See page 48.
- If you want to timer-control the recording of FM simulcast programmes, connect the tuner's power cord to the HR-D470EG's AC outlet. Set the NETZAUSGANG switch to EIN, and both the tuner and the HR-D470EG will be switched on at a time preprogrammed by the HR-D470EG. Timer-controlled recording of FM simulcast programmes is not possible with the type of tuners which reset the channel each time the power is switched off.

For customers who own a stereo TV equipped with a standardised audio/video socket

By connecting the 21-pin AUDIO/VIDEO socket of the HR-D470EG to your TV's audio/video socket, it is possible to play stereo tapes through the TV's speakers. In this case, use the A/V mode specified on your TV, instead of UHF channel 36.

CAUTION

- The HR-D470EG has a dynamic range of more than 80 dB with regards to its hi-fi audio capability. It is recommended that you check the maximum level if you are going to listen to the hi-fi audio signals through a stereo amplifier. A sudden surge in speaker input may cause speaker damage.
- Some speakers and televisions are specially shielded to prevent television interference. If both are of the non-shielded type, do not place the speakers adjacent to the TV set, otherwise the video playback picture will not be normal because of mutual interference.

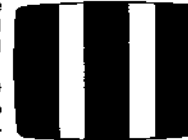
VIDEO CHANNEL SETTING

ATTENTION

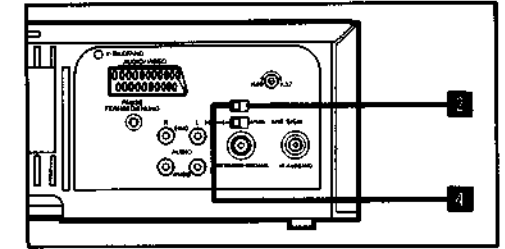
To view video programmes through the HF-AUSGANG terminal, you must set the TV's channel selector to the output channel of the RF converter. To view video programmes through the AUDIO/VIDEO socket, use the A/V mode specified on your TV.

Procedure

1. Turn on the recorder by pressing the front panel BETRIEB button. Turn on the TV receiver.
2. Set the TEST switch to EIN.
3. Adjust your TV receiver in the vicinity of UHF channel 36 until you bring in the two white signal bars on the screen as illustrated. This setting is now the VIDEO CHANNEL of the TV receiver to which the HR-D470EG is connected.
4. Reset the TEST switch to AUS.

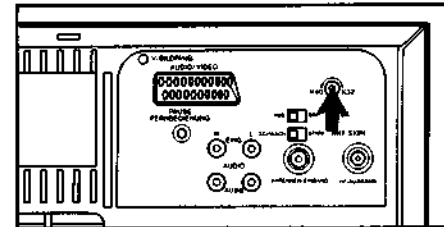


The signal from the RF converter is viewed through a vacant channel not used for broadcasting. The converter channel of all units is set to UHF channel 36 prior to shipment. Setting your TV receiver to UHF channel 36 may provide video playback. However, to obtain the best possible reproduction on your TV receiver, accurate adjustment to the RF converter output is required.



Notes:

- When you adjust your TV receiver to channel 36 for video playback, if some interference noise is seen on the screen because of broadcasts on neighbouring channels or if your preset broadcasts should be affected in picture quality, it is necessary to shift the RF converter output frequency from that of channel 36.



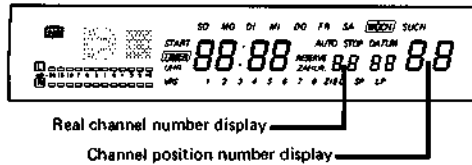
For this purpose, insert a screwdriver into a hole provided on the rear of the set and re-adjust the RF converter frequency adjustment screw in minute steps. Then tune the TV receiver once again until a clear picture is obtained.

This adjustment requires extreme precision and must be done with the utmost care. We recommend that you consult your JVC dealer for making this adjustment.

- No signal is available from the AUDIO/VIDEO socket while the test signal is being used.
- If a prerecorded VHS cassette is available, TV adjustment for VIDEO CHANNEL setting is also possible using it to obtain a playback picture. Insert the cassette and operate the HR-D470EG for playing back the cassette. Then tune the TV receiver to obtain clear pictures and sound while monitoring the playback picture on the TV screen.
- If your TV receiver is not provided with an AFC circuit, perform fine tuning of the TV receiver when you are actually viewing video cassettes.

OPERATING THE BUILT-IN TUNER

The HR-D470EG incorporates an advanced frequency synthesizer tuner which is pretuned to 112 channels to cover VHF, UHF and CATV broadcasts. Channel indication is given in two different ways: real channel numbers and channel position numbers. Real channel number indication is available by pressing the KANAL/VPS button on the sub control panel, while channel position number indication is always available in the channel display.



Correspondence between 112 pretuned TV stations and the HR-D470EG's real channel indications

Channel	01	02	03	04	05	06	07	08	09	10	11	12	13	14	15	16	17	18	19
Ch	-	E2	E3	E4	E5	E6	E7	E8	E9	E10	E11	E12	A	B	C	D	E	F	G
CC	S1	S2	S3	S4	S5	S6	S7	S8	S9	S10	S11	S12	S13	S14	S15	S16	S17	S18	S19
Channel	20	21	22	23	24	25	26	27	28	29	30	31	32	33	34	35	36	37	38
Ch	H	E21	E22	E23	E24	E25	E26	E27	E28	E29	E30	E31	E32	E33	E34	E35	E36	E37	E38
CC	S20	S21	S22	S23	S24	S25	S26	S27	S28	S29	S30	S31	S32	S33	S34	S35	S36	S37	S38
Channel	39	40	41	42	43	44	45	46	47	48	49	50	51	52	53	54	55	56	57
Ch	E39	E40	E41	E42	E43	E44	E45	E46	E47	E48	E49	E50	E51	E52	E53	E54	E55	E56	E57
CC	S39	S40	S41	-	-	-	-	-	-	-	-	-	-	-	-	-	-	-	-
Channel	58	59	60	61	62	63	64	65	66	67	68	69	-	-	-	-	-	-	-
Ch	E58	E59	E60	E61	E62	E63	E64	E65	E66	E67	E68	E69	-	-	-	-	-	-	-
CC	-	-	-	-	-	-	-	-	-	-	-	-	-	-	X	Y	Z	-	-

Stored channels

A total of 112 channels are receivable. Of them, up to 32 can be stored for easy channel selection. Prior to shipment, some channels are stored.

It is possible to store more channels or skip some channels if there are no broadcasts on those channels in your area. It is possible to change the stored channels to correspond to your preferred channel allocation. Skipped channels can be restored whenever necessary.

- Channel memories are permanent; the programmed channel allocation will not be erased even if the recorder is unplugged from the AC outlet.

Channel selection

To select a channel for recording, normally use the TV PR. (or TV PR. on the remote control) +/- buttons or 10 numeric keys. You can choose any channel from among the stored ones by calling up the corresponding channel position number.

- Use the TV PR. "-" button to scan to channel in the direction of decreasing numbers; the TV PR. "+" button, in the direction of increasing numbers.

- When using the 10 numeric keys, pay attention to the following: When 1, 2 or 3 is entered, it blinks for about 2 seconds. To set channel 1, 2 or 3, leave it blinking until it remains lit. To key in a two-digit number, enter the 2nd number while 1, 2 or 3 is blinking. The number entered first will be shifted to the tens place and channels 10 to 32 can be set. If you enter an invalid number (larger than 32), the channel display will return to the previous figure after 2 seconds.

If you want to select a channel other than those stored, engage the Real Channel mode and call up a channel while referring to the real channel number display.

With recorder's controls:

- Press the KANAL/VPS button to engage the Real Channel mode and call up a channel by either pressing the AUTO-SUCHLAUF button or using the 10 numeric keys.

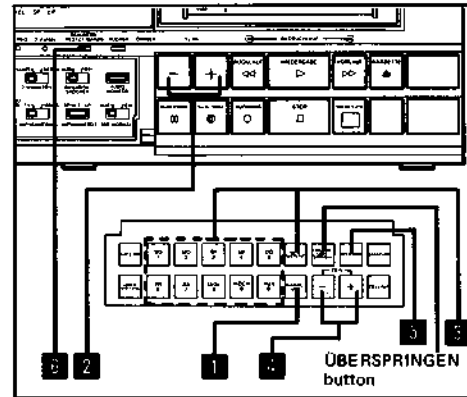
With remote control:

- Press the KANAL/VPS to engage the Real Channel mode and call up a channel by using the 10 numeric keys.

Changing the stored channels

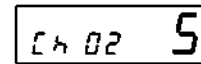


Turn the TV receiver to ON and adjust it to your video channel.

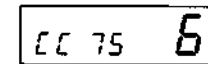


1 Press the KANAL/VPS button.

The middle 4-digit display will change to the Real Channel mode and show the band and real channel number of a station stored for that position.



VHF channel 2 is stored for channel position 5.



Cable channel 75 is stored for channel position 6.

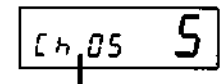
2 Call up the channel position number for which you wish to change the stored TV station.

- For this purpose, press either the TV PR. "-" or "+" button. Channel positions from 0 to 32 appear successively. "0" indicates that the unit is in the external input mode usually referred to as AUX.

3 Select a TV station which you wish to store into that position.

- Pressing the KANAL/VPS button changes the band and alternates the band indication between "Ch" (for VHF and UHF) and "CC" (for Cable). Select the appropriate indication.

- You can scan to the real channel number corresponding to the desired station by pressing the AUTO-SUCHLAUF button. Pressing the AUTO-SUCHLAUF button initiates automatic scanning from real channel number Ch 02 to 69, CC 01 to 41, 75, 76, 77, then back to Ch 02. When a broadcast is detected, scanning stops automatically. To advance to the next station, press the AUTO-SUCHLAUF button. When the button is held pressed, scanning is performed in the reverse direction while the button is being pressed.

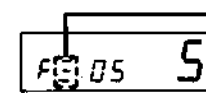


"Colon" will appear to indicate that this real channel is not stored for the indicated channel position.

- You can key in that real channel number using 10 numeric keys. 70, 71, 72, 73, 74 and numbers larger than 77 are invalid numbers. If an invalid number is keyed in, the previously selected channel will be received.

4 If the picture quality is unsatisfactory due to ghosts or other noise, perform fine tuning.

- For this purpose, press either the FEIN "-" or "+" button. The Fine Tuning mode will be engaged.



Upper or lower "-" sign indicates the operating tuning frequency is above or below the standard broadcast frequency. Centre "-" sign will appear when it corresponds to the standard.

Then press either the FEIN "-" or "+" button, depending on the direction of fine adjustment, so that the picture clears up. Each time the button is pressed, the picture condition changes in a single increment. Continuous changing is also possible by keeping the button pressed. If the tuning frequency falls on the next station, the channel number advances as well. If no command is given for 2 seconds after either FEIN button has been pressed, the Fine Tuning mode will be automatically cancelled. To cancel the Fine Tuning mode instantly, press the KANAL/VPS button.

- If the picture is not clear after all procedures, perform fine tuning on your television.

- Distorted pictures or sound will be recorded if fine tuning has not been properly performed. Exercise care with this adjustment since the recorded picture and sound cannot be adjusted later.

5 After confirming both the real channel number and channel position number, press the SPEICHERN button. "Colon" will disappear.

- The selected station will be stored in memory.

6 Press the ZÄHLWERK/RESTZT./DATUM button to disengage the Real Channel mode.

Skipping the stored channels

1 Call up the channel position number that you wish to skip by using the TV PR. buttons or 10 numeric keys.

2 Press the KANAL/VPS button.

3 Press the ÜBERSPRINGEN button.

"Colon" will appear to indicate that the displayed real channel is not stored.

4 To disengage the Real Channel mode, press the ZÄHLWERK/RESTZT./DATUM button.

- The skipped channel number will not appear on the channel display during up/down scan tuning.

Restoring the skipped channels

1 Press the KANAL/VPS button to engage the Real Channel mode.

- In this mode, all channel position numbers 1 through 32 are available in the channel display.

2 Select the channel position number that you wish to restore by using the TV PR. "-" or "+" button.

3 Select a real channel that you wish to restore in that channel position by using the AUTO-SUCHLAUF button or 10 numeric keys.

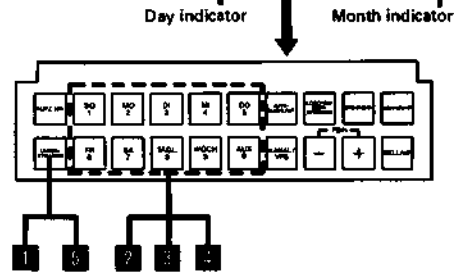
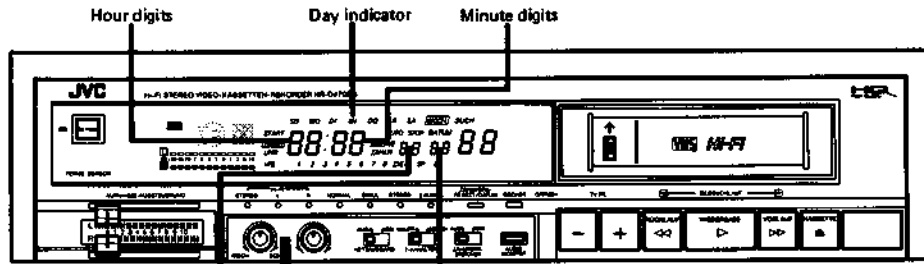
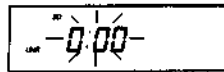
4 After confirming both the real channel number and channel position number, press the SPEICHERN button.

5 To disengage the Real Channel mode, press the ZÄHLWERK/RESTZT./DATUM button.

CLOCK SETTING

Plug the HR-D470EG into an AC outlet. The display shows a flashing 0:00 with SO and UHR illuminated. This initial display also functions as a power failure indicator.

Power failure indicator



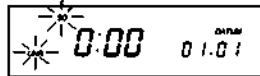
Set the hour and minute in that order.



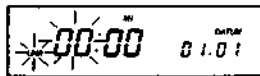
- The flashing position is ready for entry.
- To set a one-digit number, first press "0", then press the numeric key for 1 to 9.
- Zero will not be displayed in the tens place of the hour indication unless the cursor is moved back to the hour digits.
- For a two-digit number, simply press the corresponding numeric keys in the right order.
- In hour setting, numbers larger than 23 will be rejected.
- In minute setting, numbers larger than 59 will be rejected.
- Set the day and month in that order.
- The flashing position is ready for entry.
- The setting method is the same as for time setting.
- In day setting, invalid numbers such as 32 of January or 30 of February will be rejected.
- In month setting, numbers larger than 12 will be rejected.

Press UHREINSTELLUNG.

The display will change to the Clock Set mode with "SO" and "UHR" flashing.

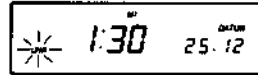


Press one of the numeric keys "1 (SO)" to "7 (SA)" that corresponds to the day of setting. The hour digits will start flashing.



Press UHREINSTELLUNG.

Press it at the exact instant of the time signal, and the clock will be set accurately to the present time.



Notes:

- If you press a wrong numeric key, you can return to the previous position using the reverse cursor key TV PR.
- Once all necessary data have been entered, you can reach any position for correction using the reverse and forward cursor keys TV PR.
- Readjust the date in leap years.

Clock/timer memory backup

- The built-in memory backup battery allows for correct time-keeping for about 60 minutes after the recorder is unplugged from the AC outlet. During this period of power outage, the preprogrammed timer data are also maintained, although the display blacks out.
- The memory backup battery is being recharged when the recorder is not in use. For the fully-depleted battery to be recharged sufficiently for 60-minute backup, it takes more than 30 minutes.
- When the backup time is expired, the power failure indicator shown above will appear when power is reapplied.

INFORMATION ON THE HR-D470EG'S AUDIO SYSTEM

Hi-Fi and normal audio

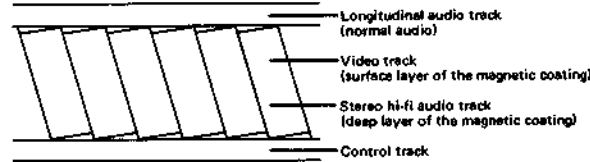
To provide true hi-fi audio accompaniment to video entertainment and, at the same time, compatibility with regular VHS tapes, the HR-D470EG employs a unique audio recording system. Hi-fi audio signals (2-channel) are recorded deep into the tape's magnetic coating, and the video signal is recorded on top of the audio signals in a shallower layer. At the same time, another audio head records normal audio signals (monaural)

onto the usual longitudinal audio track. Since this longitudinal audio track is exactly the same as on regular VHS tapes, tapes recorded on the HR-D470EG can be played back on other VHS machines, and vice versa.

CAUTION:

The hi-fi soundtrack recorded with the HR-D470EG cannot be reproduced with video equipment other than Hi-Fi VHS.

Tape pattern recorded with the HR-D470EG



Hi-fi audio recording and reproduction are available only from the hi-fi audio track while the longitudinal audio track provides normal audio.

The hi-fi and normal soundtracks are recorded simultaneously.

Recording options according to the selected input mode

Input mode	Track	Video track	Normal audio track (mono)	Hi-fi audio track (2-channel)
TV	TV picture (from built-in tuner)			
	TV picture (from built-in tuner)			Audio signal from AUDIO EING.
AUX	Channel display section	Video signal from AUDIO/VIDEO	Audio signal from AUDIO/VIDEO	

Notes:

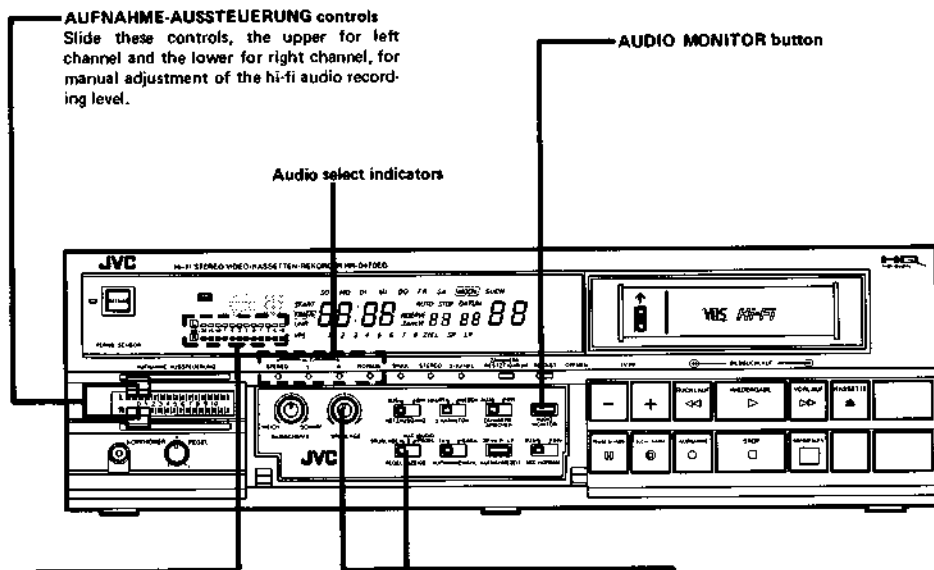
- To engage the AUX mode, press the "0" key of the 10-digit keypad.
- For audio-only recording, refer to page 49.

Recording options according to the type of broadcasts and the setting of the 2-KANALTON switch

Type of broadcast	2-KANALTON switch position	Audio Track	Normal audio track (mono)	Hi-fi audio track (2-channel)	
				L	R
Regular (monaural audio)	Either position		Mono	Mono	Mono
Stereo broadcast	Either position		L + R mixed	Stereo	
Bilingual broadcast	HAUPT (2-KANALTON)	Main soundtrack (local language)		Main soundtrack (local language)	Sub soundtrack (foreign language)
	NEBEN (2-KANALTON)	Sub soundtrack (foreign language)		Main soundtrack (local language)	Sub soundtrack (foreign language)

Hi-Fi audio recording level adjustment

While recording onto the normal audio track is controlled by the built-in Automatic Level Control circuit, hi-fi audio recording is controlled manually.



AUFNAHME-AUSSTEUERUNG controls
Slide these controls, the upper for left channel and the lower for right channel, for manual adjustment of the hi-fi audio recording level.

AUDIO MONITOR button

Audio select indicators

Audio level indicators

For manual control of the recording level, first set the relevant switches as follows:

PEGELANZEIGE → EIN

AUDIO MONITOR → HI-FI STEREO

Then slide the AUFNAHME-AUSSTEUERUNG controls referring to these indicators. When indicators up to or near 0 dB light for the loudest signal being applied, the recording level is optimum. (The level at which only one red indicator lights from time to time may be most appropriate.) During playback, these indicators show the level of audio signals recorded on the tape and selected with the AUDIO MONITOR button.

If no signal is recorded on the hi-fi audio track, the level of normal audio is automatically indicated.

These indicators do not light when the PEGELANZEIGE switch is in the AUS position.

Notes:

- With the AUDIO MONITOR select button set for L, R or NORMAL, the recording level of hi-fi audio signals cannot be correctly indicated. Select the HI-FI STEREO position when adjusting the recording level.
- The normal audio signal level is also displayed by these indicators, but cannot be adjusted.

PEGELANZEIGE switch and SPURLAGE control

The right-channel audio level indicator also functions as a tracking meter during playback. If noise or breaks are sensed in the reproduced sound from the hi-fi audio track or noise bars are visible on the screen, attempt to correct using the SPURLAGE control while referring to the meter. For this purpose, set this switch to HI-FI SPURLAGE and turn the SPURLAGE control so that the greatest number of elements of the right-channel indicator light.

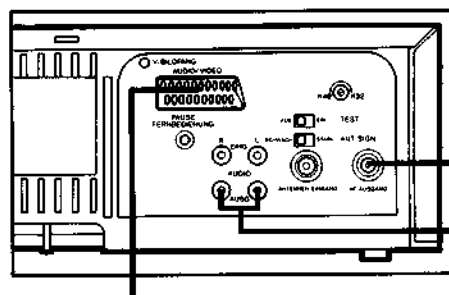
When this switch is set to AUS, the indicators do not light, regardless of whether during recording or playback.

Note:

- When playing back a tape with no recording on the hi-fi audio track, the level indicator does not light when the PEGELANZEIGE switch is set to SPURLAGE.

Dual-audio playback flexibility

Two different types of audio tracks (hi-fi and normal) allow a variety of playback options depending on the connection and the settings of relevant controls and switches.



HF-AUSGANG connector

Delivers audio (both hi-fi and normal) and video signals to a TV receiver. When the recorder is not used, the antenna signal is supplied from this connector to the TV receiver to allow regular TV viewing; when a video tape is played back through the HF-AUSGANG connector, the audio is reproduced always as monaural; with hi-fi stereo tapes, both channels are mixed or the one selected by the AUDIO MONITOR button is reproduced. Therefore, for stereo playback, connect a stereo system to the AUDIO AUSG. connectors or a stereo television to the AUDIO/VIDEO socket.

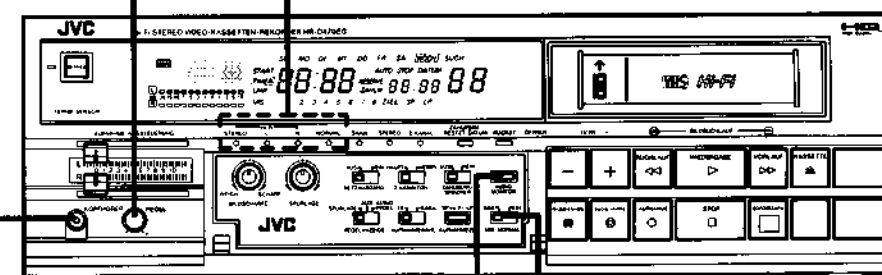
AUDIO/VIDEO socket

Delivers audio (both hi-fi and normal) and video signals. (Also accepts audio and video signals for recording from other video equipment.)

AUDIO AUSG. connectors

Delivers the audio signals from both hi-fi and normal audio tracks.

Headphone level control **Audio select indicators**



KOPFHÖRER jack

Delivers the audio signals from both hi-fi and normal audio tracks. The headphone output level is adjustable with the headphone level control.

MIX NORMAL switch

Operates in conjunction with the AUDIO MONITOR button to select soundtracks for listening.

- Set to EIN to listen to a mixture of Hi-Fi and normal soundtracks by selecting the combination with the AUDIO MONITOR button.

Notes:

- This switch functions during recording as well, although it has no effect on the recorded signal.
- When playing back a tape containing the same soundtrack on both hi-fi and normal audio tracks, a slight time lag is sensed between the two soundtracks, probably with some distortion, in the EIN position. Therefore, in such a case, use the AUS position.
- Set to AUS to listen to each soundtrack independently by selecting it with the AUDIO MONITOR button.

AUDIO MONITOR button

Selects the hi-fi audio channel (left, right or both) or the normal soundtrack for listening. Use this button together with the MIX NORMAL switch referring to the four indicators (HI-FI STEREO, L, R and NORMAL).

- Set to HI-FI STEREO to listen to a stereo soundtrack.
- Set to L to listen to the hi-fi left channel sound.
- Set to R to listen to the hi-fi right channel sound.
- Set to NORMAL to listen to the normal sound.

Note:

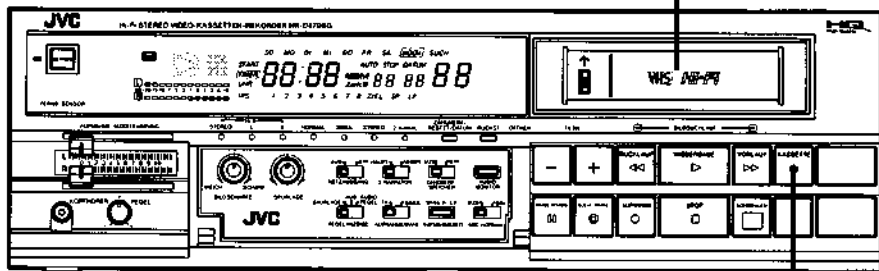
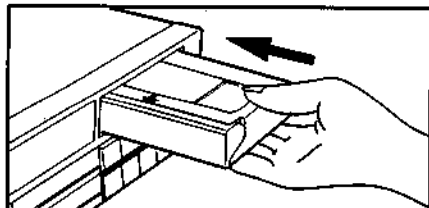
- This button functions during recording as well, although it has no effect on the recorded signal.

LOADING AND UNLOADING A CASSETTE

Loading

Insert a cassette endways, with the small arrow on the cassette pointing to the left.

- With a cassette inserted, the **CD** mark to indicate "cassette inserted" appears on the FDP. Even after the power is turned off, this mark remains lit as long as the cassette is inside the recorder.



Unloading
Press KASSETTE.
The cassette will be ejected.

New motorised loading system/Auto-play function

- As long as the AC power cord is plugged in, the cassette can be loaded even when the power has not been turned on. Inserting a cassette into the loading slot turns the power on automatically.
- Inserting a cassette, with its safety tab removed, turns the recorder on and playback of the cassette begins automatically.
- The cassette can be unloaded even when the power has been turned off. If a cassette is inside, pressing the KASSETTE button turns the power on automatically and, after ejection of the cassette, shuts it off automatically.

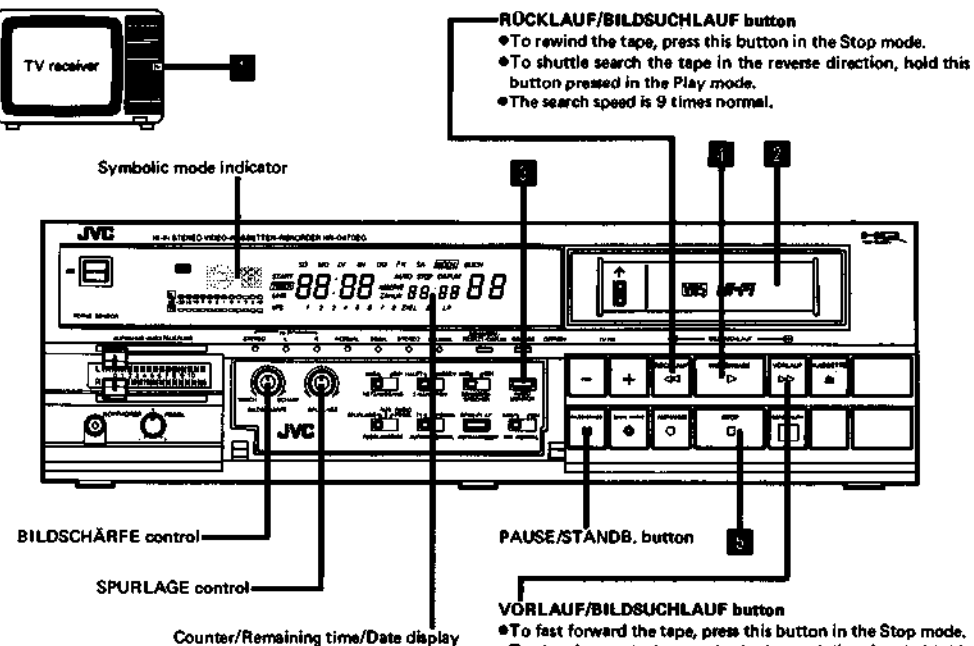
Notes:

- Be sure to insert the cassette firmly into the slot; otherwise, it will be automatically ejected.
- The automatic loading mechanism will operate only when the cassette is inserted correctly.
- A cassette inverted cannot be inserted.

CAUTION

- If unloading of a cassette is not possible, check to see whether the TIMER indicator is lit. If so, press the SCHALTUHR button so the TIMER indicator extinguishes.
- Do not attempt to pull out the cassette once automatic loading has started.
- Do not insert fingers or any foreign object beyond the door flaps of the cassette loading slot, as this could lead to injury or damage to the mechanism. Show special caution with children.

PLAYING BACK A VIDEO CASSETTE



Switch ON.

- Adjust the TV receiver's channel to your video channel.
- Load a pre-recorded cassette. Power will be switched on automatically. When the cassette loaded has no safety tab, playback will start automatically.
- Set the AUDIO MONITOR button as required (also check the MIX NORMAL switch). See page 44.
- Press WIEDERGABE.
- Press STOP at the end of the programme.

Notes:

- The AUFNAHMEZEIT switch may be in either position. The SP or LP mode recording is automatically detected and played back at a correct speed respectively. The engaged mode will be displayed on the FDP.
- With LP mode recordings, only the audio portion is reproduced.
- The tape-end auto-rewind mechanism functions in both the Play and Fast Forward modes.
- When the PAUSE/STANDB. button is pressed during playback, a still picture will appear. The still picture can be advanced each time this button is pressed. To cancel the Still mode, press the WIEDERGABE button.
- Images on the screen can be adjusted to a preferred softer or sharper definition by turning the BILDSCHÄRFE control in the corresponding direction.

RÜCKLAUF/BILDSUCHLAUF button

- To rewind the tape, press this button in the Stop mode.
- To shuttle search the tape in the reverse direction, hold this button pressed in the Play mode.
- The search speed is 9 times normal.

VORLAUF/BILDSUCHLAUF button

- To fast forward the tape, press this button in the Stop mode.
- To shuttle search the tape in the forward direction, hold this button pressed in the Play mode.
- The search speed is 9 times normal.

Memory play function

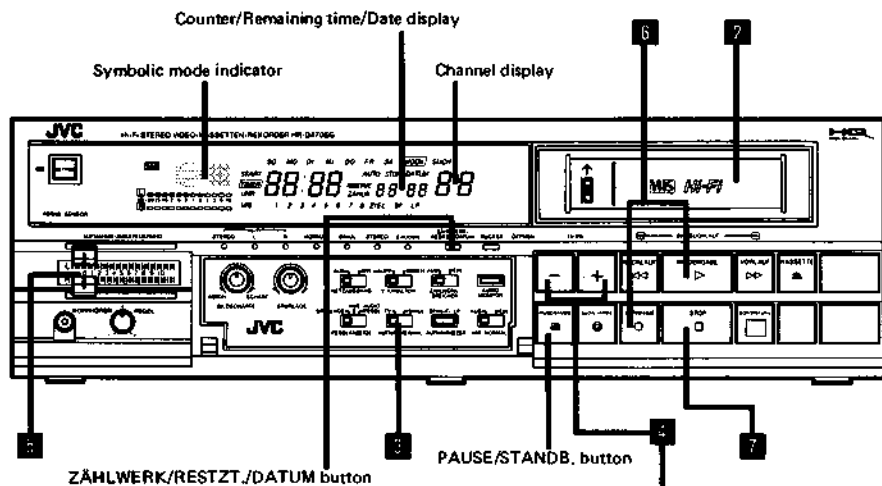
- If you want to watch the same tape again from the beginning, press the WIEDERGABE button within 2 seconds after you have pressed the RÜCKLAUF button. Playback will start automatically after the tape has been rewound to the beginning. In this case, while the tape is being rewound, the symbolic mode indicator for WIEDERGABE will be blinking.
- When used in conjunction with the counter memory function, this memory play is also available at the counter reading of "0000" after either rewind or fast forward. (For more details of the counter memory function, refer to page 57.)

- When the Still mode continues for longer than about 5 minutes, the Stop mode will be entered automatically.
- Noise bars may appear on the screen if you playback a tape which was recorded using another recorder. In such cases, adjust the SPURLAGE control. Turn it in either direction to adjust the picture. After playing a particular tape, return the control knob to the centre position.
- With some televisions, the still picture may be unstable. This is not due to any defect of the unit.
- When listening through headphones, if the volume is too weak or too loud, adjust the headphone level control for comfortable listening.

BASIC OPERATION FOR RECORDING TV PROGRAMMES



This section describes the step-by-step procedure for recording a TV programme while watching it, assuming that it is a regular (monaural audio) programme. For other recording options, refer to the next page where variations from this basic operation are described.



- 1 Switch on the TV receiver and adjust its channel to your video channel.
- 2 Load a cassette. Power will be switched on automatically.
- 3 Set AUFNAHMEWAHL to TV.
- 4 Select the channel you wish to record.
- 5 Hi-Fi audio recording level adjustment. Refer to page 43.
- 6 Press AUFNAHME and WIEDERGABE simultaneously to start recording.
- 7 Press STOP at the end of the programme.

CAUTION
Check to see if the "LP" indicator on the FDP is lit. If so, press the AUFNAHMEZEIT button to obtain "SP" on the FDP, otherwise the pictures will not be recorded.

Notes:

- If there is part of the programme you don't want to record, press the PAUSE/STANDB. button. A white bar appears on the TV screen to keep the user aware the unit is in the Pause mode. To release the Pause mode, press the WIEDERGABE button.
- When recording is restarted from the Pause mode, assemble recording is performed so that the playback picture will not distort at the edit point. A few frames recorded before the pause are erased due to overlap of the new recording. This is not due to any defect of the unit.
- When a recording containing assemble edits (segments recorded using the PAUSE function) is played back, noise may appear momentarily at edit points. This is not due to any defect of the unit.
- When the Pause mode continues for longer than about 5 minutes, the Stop mode will be entered automatically.
- The built-in tuner's automatic channel lock mechanism prevents the selected channel from being altered during recording. Therefore, if you wish to change the channel during recording, first engage the Pause mode and then select a different channel.
- If the AUFNAHME button cannot be engaged, check to see if the cassette safety tab has been removed. (See page 33.)
- When the end of the tape is reached during recording, the tape is automatically rewound to the beginning and stops.
- Press the ZÄHLWERK/RESTZT./DATUM button to check how much recording time has elapsed. (For more details refer to page 57.)

RECORDING A TV PROGRAMME WHILE WATCHING ANOTHER

A programme not being viewed can be recorded while you enjoy another programme. This permits the recorded programme to be played back later at your convenience.

The recording procedure is exactly the same as described on the previous page. The points to be remembered are:

- Select the channel you wish to record with the recorder's channel select buttons.
- Select the channel you wish to view with the TV receiver's channel selector.

RECORDING STEREO TV PROGRAMMES

If stereo TV programmes are broadcast in your area, the HR-D47DEG automatically receives them in stereo. When a stereo programme is being received, the STEREO indicator lights and recording is made in stereo on the hi-fi audio track and in mono (mixed L + R) on the normal audio track. To listen to the stereo soundtrack during recording, set the AUDIO MONITOR button for Hi-Fi STEREO. If this button is left either in the L or R position, you will hear only one channel while recording, though the recording is being made in stereo.

RECORDING BILINGUAL TV PROGRAMMES

When a bilingual TV programme is being received, the 2-KANAL indicator lights. There is a switch to select the soundtrack to be recorded on the normal audio track, however, because both soundtracks are recorded always on the hi-fi track for selective listening, you can ignore the switch labelled 2-KANALTON in most cases unless you need a specific soundtrack on the normal audio track.

- Set the 2-KANALTON to HAUPT to record the main soundtrack (local language); to NEBEN to record the sub soundtrack (foreign language).
- To listen to the selected soundtrack from the hi-fi audio track while recording, set the AUDIO MONITOR button for either L or R.
- To listen to the soundtrack being recorded on the normal audio track, set the AUDIO MONITOR button for NORMAL.

RECORDING FM SIMULCAST TV PROGRAMMES

FM simulcast TV programmes can be recorded using an FM stereo tuner. Connect necessary components. (Connect the FM tuner to the rear panel AUDIO EING. connectors.) Select the TV channel broadcasting the simulcast programme with the recorder's channel select buttons and tune the FM stereo tuner to the station broadcasting the soundtrack for this TV programme.

The only difference from the basic recording procedure is in step 3.

- Set the AUFNAHMEWAHL switch to SIMUL. Then the SIMUL indicator will light. With this setting, the video and audio signals from the built-in tuner will be recorded on the video and normal audio track and the audio signal from the FM stereo tuner will be recorded on the hi-fi audio track.

Notes:

- After finishing recording, be sure to set the AUFNAHMEWAHL switch to TV.
- While recording simulcast programmes, it might happen that the hi-fi sound distorts momentarily at switching points between different programmes. This is not due to any defect of the unit.

RECORDING A TV PROGRAMME WHILE RECORDING AN INDEPENDENT AUDIO SOURCE

Using the "simulcast" recording function, you can record independent audio and video programmes, because the TV soundtrack is not lost, but recorded on the normal audio track. While recording a TV programme, record any audio source independently.

- Connect an audio component (such as an FM tuner) to the AUDIO EING. connectors.

- Set the AUFNAHMEWAHL switch to SIMUL.

Notes:

- If you stop recording to avoid unwanted material of the TV programme using the PAUSE/STANDB. button, the audio programme from an external source is also cut.
- If television broadcasting comes to an end during recording, the hi-fi sound being recorded from an external source may distort. It is recommended that you check the timetable of TV broadcasts in advance.
- After finishing recording, be sure to set the AUFNAHMEWAHL switch to TV; otherwise recording on the hi-fi audio track from the built-in tuner will not be possible.

USING THE HR-D470EG AS AN AUDIO DECK

You can record audio only (without recording any video signal) in either the SP or LP mode. In the LP mode you can enjoy up to 8 hours of hi-fi stereo recordings with a single cassette (E-240).

Recording from the AUDIO EING. connectors

- Connect an audio source (such as an FM tuner) to the AUDIO EING. connectors.
- Set the AUFNAHMEWAHL switch to SIMUL.
- Select the LP mode with the AUFNAHMEZEIT button.

Notes:

- The input signal is recorded only on the hi-fi audio track.
- Tune the built-in tuner to a vacant channel, if the SP mode is selected.
- In the LP mode, no video signal is recorded. However, the audio signal from the built-in tuner is recorded on the normal audio track; to avoid this, tune the built-in tuner to a vacant channel in this case as well.
- When playing back audio-only tapes that were recorded in the simulcast mode, with the tuner set to a vacant channel, Music Scan is not available, even if the SUCHL. MARKE button was used during recording. This is because nothing is recorded on the normal audio track.

Recording from the AUDIO/VIDEO socket

- Connect an audio source (such as a Hi-Fi VHS deck) to the AUDIO/VIDEO socket.
- Press the "0" key of the 10-digit keypad.
- Select the LP mode with the AUFNAHMEZEIT button.

Note:

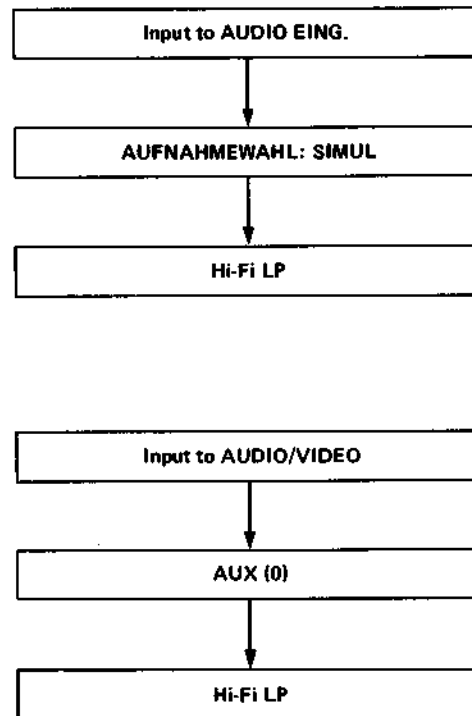
- In the LP mode, no video signal is recorded. The input audio signal is recorded on both the normal and hi-fi audio tracks. Therefore, the Record Mute function (see page 55) can be used for Music Scan in playback.

Playback of audio-only recordings

- When the cassette is inserted, the SP or LP mode recording is automatically detected and played back at a correct speed respectively with "SP" or "LP" lit on the FDP.
- Select the soundtrack (Hi-Fi STEREO, L or R) as required with the AUDIO MONITOR button.

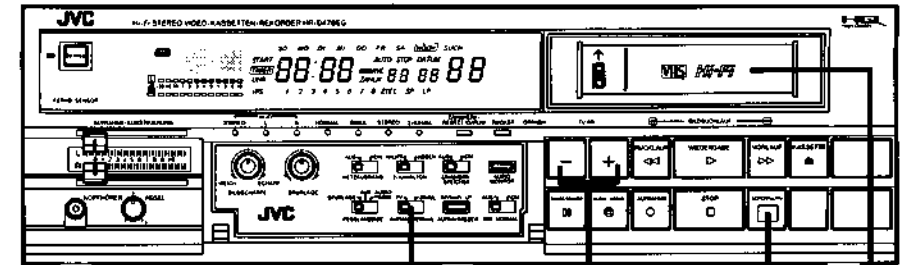
Note:

- After recording or playback in the LP mode, be sure to reset the mode to SP by pressing the AUFNAHMEZEIT button. When you play a regular video tape or SP mode audio-only tape, the mode will be automatically restored to SP.

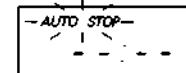


INSTANT RECORDING

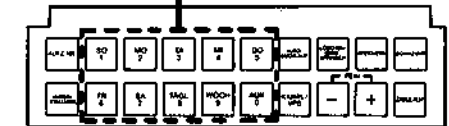
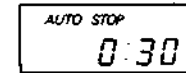
Besides starting and stopping a recording as usual, the HR-D470EG offers a more convenient possibility: starting by the push of a single button, and recording will stop automatically after a certain period of time. Use this facility for starting a recording before you go to bed or leave home.



- 1 Load a cassette.
- 2 Set to TV.
- 3 Select the channel from which you want to record. (Numeric keys can also be used.)
- 4 Press SOFORTAUFN.
 - The following indication will appear on the display, to show that the recorder is ready to start recording.
 - The AUTO STOP indicator on the display will flash.



- 5 Press SOFORTAUFN. once again.
 - Recording will begin immediately and the following indication will appear on the display, showing that recording will automatically stop and power will switch off after 30 minutes.
 - The AUTO STOP indicator remains lit.



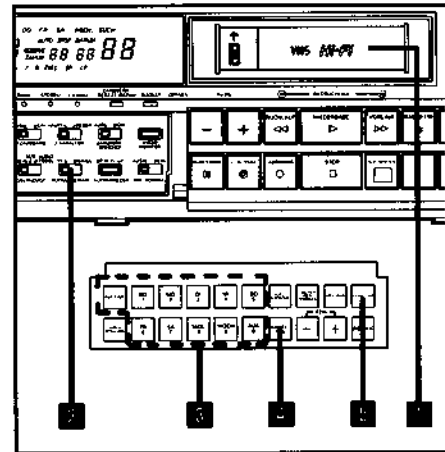
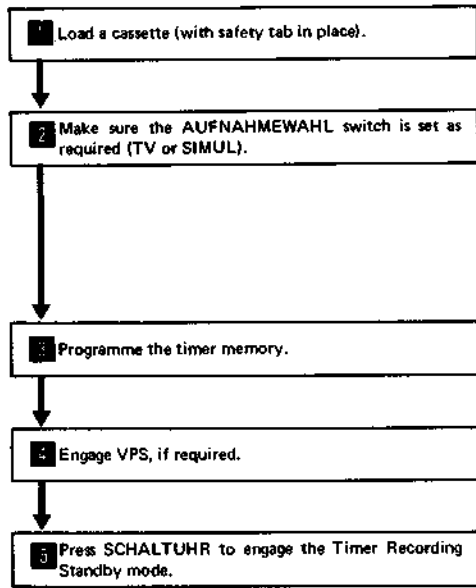
- 6 Each time the SOFORTAUFN. button is pressed, recording time increases by 30 minutes up to 4 hours.
 - For a more precise time setting, use the numeric keys after recording has started. For this purpose, after "0:30" has appeared, specify the time using the numeric keys and press the SOFORTAUFN. button immediately. (Always key in a full number including hours and minutes. For "0:35", key in zero first.)

Notes:

- If the SOFORTAUFN. button is not pressed a second time within about 10 seconds after it has been pressed once, the Instant Record mode will be cancelled and the display will change back to the Counter mode.
- If you want to change the time setting again after the SOFORTAUFN. button has been pressed for memorisation of new data, simply press SOFORTAUFN. and redo the programming.
- While recording is in progress, the displayed time counts down; when 0:00 is reached, the Record mode is released after 10 seconds and the power is switched off.
- If you want to stop recording after having started recording in the Instant Record mode, press the STOP button.
- The instant recording function can also be used as a sleep timer. If you press the SOFORTAUFN. button during normal recording, the AUTO STOP indicator will light on the display and the indication "0:30" will be obtained, showing that recording will stop automatically after 30 minutes. The time span can be adjusted in the same way as for instant recording.
- Instant recording has priority over all other modes including VPS recording. If a preset VPS programme starts during instant recording, recording of that VPS programme will begin only after the Instant Record mode has ended.
- If the SOFORTAUFN. button is pressed with a non-recordable cassette loaded (one with its safety tab removed), the cassette will be automatically ejected.
- If you want to perform instant recording after you have set the timer with the SCHALTUHR button engaged and the TIMER indicator lit, press the SOFORTAUFN. button as usual. Power will be turned on and instant recording will start. After instant recording has been performed, the Timer mode is automatically re-entered and power is turned off.
- If the programmed switch-on time for a timer recording should come after the switch-off time of the instant recording, this timer recording will still be made automatically.

AUTOMATIC VPS OR TIMER RECORDING

Basic Procedure



Use either the recorder's controls or the remote control's keys.

VPS recording

VPS stands for the Video Programme System which adds flexibility to timer recording with a video cassette recorder. In this system, TV stations transmit special VPS codes using a multiplex system while certain programmes are being broadcast; the codes are different for different programmes. These VPS codes control the starting and stopping of the video recorder and have precedence over times preset in the timer. Using the VPS function, if a programme starts earlier or later than scheduled or overruns its scheduled time, it will be recorded from start to finish. The HR-D470EG incorporates a VPS decoder which detects the VPS codes and controls power on/off and tape start/stop. First programme the timer, then, if you switch on the VPS function, all timer data – day, start time, stop time and channel – are converted to VPS codes and stored in memory. When the VPS function is not engaged, the timer starts and stops recording in the usual way. If the VPS function is engaged, the HR-D470EG will enter the VPS standby mode at 20:00 on the day previous to the preset day and remain engaged until 4:00 on the following day, if the intended programme has not been broadcast. This means that if the required programme starts within this 32-hour period it will be recorded correctly.

One-year calendar timer

"One-year" presetting capacity means that you can "reserve" a recording on any day, even one year in advance. One extreme case: If the date entry corresponds to the current day and the START time is set to a time before the current time, recording will start on the same day next year.

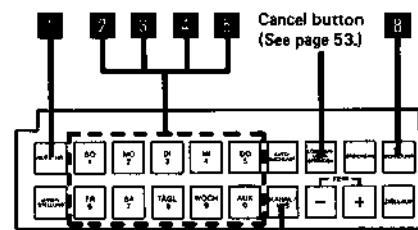
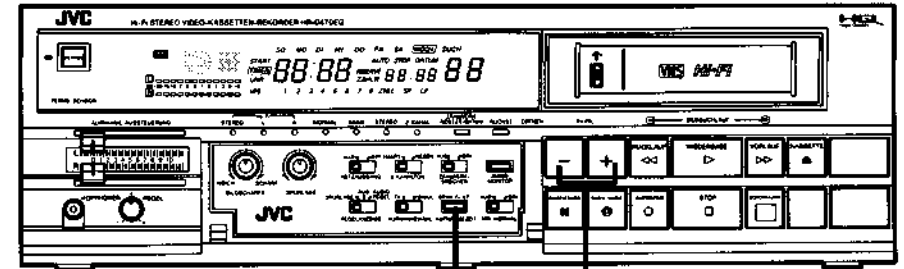
8-Programme timer

"8-Programme" presetting capacity means that you have 8 separate timers which contain different programming data. Because of this capacity, you can even "reserve" 8 different TV programmes, either on the same day or on different days.

Each programme (No. 1 through No. 8) contains information on "date" (or "daily"), "start time", "stop time", "TV channel number", "SP or LP" and "VPS or regular".

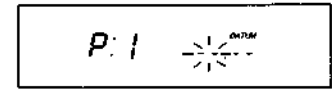
Example of the contents of one programme entry:

Programme number	TV channel number	Date	Start time	Stop time	Recording mode	VPS
2	12	05.12	10:30	11:30	SP	VPS

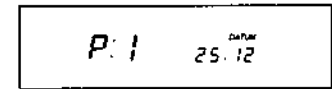


Cursor keys
(See page 53.)

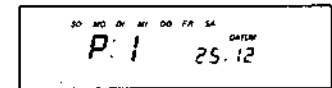
- Press AUFZ. NR. The display will change to the Timer Set mode with P 1 illuminating and the date display section flashing. You are ready to enter the data into No. 1 programme memory. To advance to programme numbers 2 – 8, press again. After programme 8, the Clock mode will be engaged.



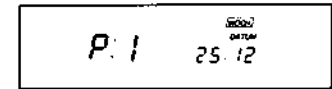
- Enter the date using numeric keys.



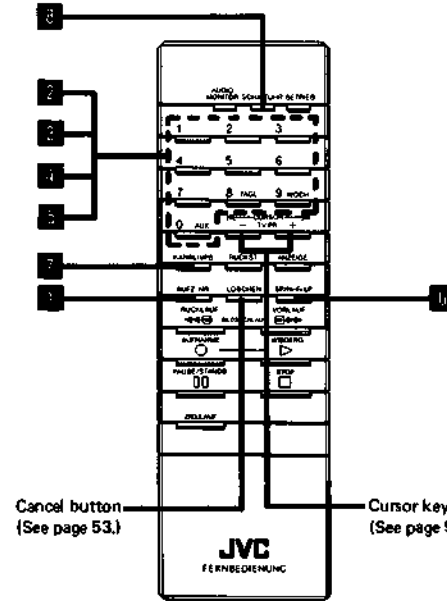
- Invalid numbers will be rejected.
- To record a daily serial starting on the day of setting, move the cursor with the "+" button to the START time setting without entering any date figure.
- To record a daily serial starting on a certain day, press [3] (TAGL.) and enter the date.



- The "daily" entry can be cancelled by pressing [8] again.
- To record a weekly serial, press [9] (WÖCH.) and enter the date.



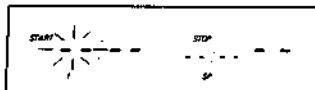
- The "weekly" entry can be cancelled by pressing [3] again.
- Both "daily" and "weekly" information can be entered or cancelled also in the time setting stage.
- When both day and month data have been entered, the display will change to the time setting mode and the programme number will be displayed at the bottom of the FDP panel.



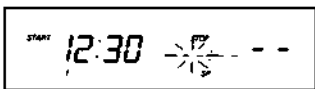
Cancel button
(See page 53.)

Cursor keys
(See page 53.)

■ Key in the start time.

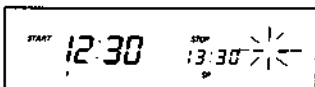


- To key in a one-digit number of hours or minutes, first press [0]. Then press the relevant numeric key.
- The minute digits will start flashing after keying in the hour.
- The hour digits of the "STOP" time will start flashing after keying in the start time.



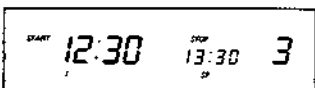
■ Key in the stop time in the same manner as the start time.

- The digits of the channel display will start flashing after keying in the stop time.

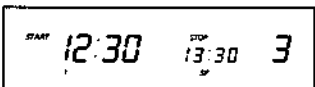


■ Enter the channel.

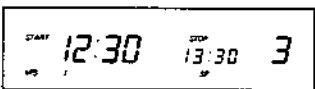
- Invalid numbers will be rejected.
- For a two-digit number, enter the second digit while the digit entered first is blinking. (See page 41.)



■ Select the recording speed by pressing AUFNAHMEZEIT (SP/Hi-Fi LP on the remote control).



- The SP or LP entry can be made anytime while in the Timer Set mode.
- For VPS recording, press KANAL/VPS button.
- VPS can be entered or cancelled anytime while in the Timer Set mode by pressing KANAL/VPS.

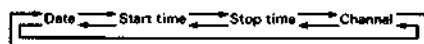


■ Press SCHALTUHR button.

- The TIMER indicator will light. (For error indications, see page 54.)
- The display will return to the Clock mode, also showing the programme numbers for which recording data has been programmed.

How to use the cursor keys

- If you press a wrong key and the flashing position has advanced, press "-" to return to the previous position for correction.
- Once all data have been programmed, you can reach any position for correction using "-" or "+". The flashing position is ready for re-entry.
- The cursor (flashing position) advances or returns in the following order.



(Pressing AUFZ. NR. engages the check mode in which no position flashes and data correction is not possible. To correct the data, press either cursor key; "+" to move to "Date" or "-" to move to "Channel".)

Setting the DATUM, START and STOP times

- It is not possible to set the DATUM, START and STOP times unless the date and the clock time have previously been set.
- Enter the data while the digit positions are flashing.
- Unless the START time has been properly set, STOP time setting is not possible.
- The STOP time can be set within 24 hours from the START time. If the hour setting for the STOP time runs into the following day, there is no need to set the day. Recording will stop at the preset time on the following day.
- Non-applicable numbers (such as January 32, February 30 for dates, 24 or larger for hours, 60 or larger for minutes and 33 or larger for channels) will be rejected when keyed in.
- In leap years, be sure to readjust the date in the Clock mode, otherwise timer recording will not be performed correctly.

Last-channel memory

- The currently tuned channel locks in the Timer Set mode and, when the display returns to the Clock mode, the locked channel is displayed.

Cancelling the preset data

- The preset programmes can be cancelled by pressing the LÖSCHEN/ÜBERSPRINGEN button. For this purpose, first engage the Timer Set mode for the number you wish to cancel and then press the LÖSCHEN/ÜBERSPRINGEN button.
- Unless the VPS mode is engaged, an executed programme is automatically cleared.

Checking the programmed data

- Checking and re-programming can be performed anytime, even when the SCHALTUHR button has already been engaged.
- While recording is actually taking place in the regular Timer mode, the STOP time can be changed. For this purpose, engage the Timer Set mode and move the cursor; only "STOP" time will flash. This means you can re-programme the stop time.
- While recording is actually taking place according to one preset programme, all other preset programmes can be checked or re-programmed.
- To disengage the Timer Set mode, press the ZÄHLWERK/RESTZT./DATUM button (on the recorder) or the ANZEIGE button (on the remote control).

Additional information for timer setting and operation

TIMER indicator (Error indication)

- When the SCHALTUHR button is pressed with a cassette loaded and the timer correctly programmed, the TIMER indicator on the display will light with the corresponding programme number(s) also lighting and the power is turned off.
- When you have preset several programmes at a time, confirm that all the preset programme numbers light together with the TIMER indicator when the SCHALTUHR button is pressed. The programme whose number does not light has not been correctly preset. Reread the programmed data.
- Programming errors include cases where either "START" or "STOP" time has not been preset, or both these preset times are the same. A "no-channel-programmed" situation is not interpreted as an error, and recording will be made of the currently tuned channel.
- If all programmes have been wrongly preset, the TIMER indicator will flash for about 10 seconds when the SCHALTUHR button is pressed, and remain lit with no programme number lit.
- If the SCHALTUHR button is pressed when a cassette is not loaded, the TIMER indicator will continue blinking.
- If a cassette with its safety tab removed has been loaded, it will be ejected automatically when the SCHALTUHR button is pressed. The TIMER indicator will continue blinking.
- As long as the SCHALTUHR button is engaged, unloading of a cassette is not possible.

VPS operation

- When a VPS code corresponding to the intended TV programme is detected, recording will start with "VPS" blinking. When the VPS code changes to another, recording will stop.
- If no VPS code is detected during the VPS standby mode (for example, the tuned-in station does not transmit VPS codes), ordinary timer recording will be engaged; recording will start at the preset time and stop at the preset time.
- When an interruption code is detected during VPS recording, the recorder enters the VPS standby mode and restarts recording when the regular VPS code is restored.
- When the VPS code stops for some reason during VPS recording, recording will stop at the preset stop time.
- If a system status code which cancels VPS recording is detected during the VPS standby mode, ordinary timer recording will be engaged.
- During VPS recording, the number of the programme that is presently operating and the indication "VPS" will be blinking.
- After VPS recording, the power is switched off and the auto rewind mechanism does not function. If the end of the tape is reached during VPS recording, the cassette is automatically ejected and then the power is switched off.

Regular timer operation

- If the VPS mode is not engaged, tape loading starts 20 seconds before the preset START time and the recording start signal is triggered 2 seconds before the preset time so that recording starts exactly at the preset time.
- During timer recording, the number of the programme that is presently operating will be flashing.
- Operation at the end of recording is the same as with VPS operation.

Programme priority

- If several programmes have preset times which overlap, as a rule, VPS programmes have priority and, among VPS programmes, the smaller programme number has priority.

MUSIC SCAN AND RECORD MUTE FUNCTIONS

The Music Scan function automatically locates the beginning of a specified musical selection and starts playback automatically. With the HR-D470EG, up to 9 musical selections can be scanned in both forward and reverse directions. For the Music Scan function to operate properly, there must be non-recorded sections (blanks) between musical pieces on the normal audio track, which can be made by the Recording Mute function during recording.

Music Scan

- Specify the number of the desired musical selection during playback by pressing one of the numeric keys (1 - 9).
 - The SUCH indicator and the specified number will appear on the FDP.
- Press the VORLAUF or RÜCKLAUF button within 2 seconds, depending on the desired scanning direction.
 - When the specified musical selection is reached, the SUCH indicator will turn off and playback will start automatically.
 - If pictures are also recorded on the tape and the television is on, the search picture is visible on the screen.
 - To cancel the Scan mode during scan, simply press the WIEDERGABE button; normal playback will resume.

Notes:

- The Music Scan function will not operate properly in the following cases:
 - The score itself contains lengthy pianissimo or silent periods.
 - Overall recording level of the tape is too low.
 - Blanks between passages are too short (less than 5 seconds).
 - Blanks contain noise or hum.
- If any blank is not detected during the first 10 minutes of scanning, the Scan mode is cancelled and playback resumes.
- If you want to correct the number during scan, simply re-enter a different number.
- If the end of the tape is reached during scan, the Scan mode is cancelled and the tape is automatically rewound.

Record Mute

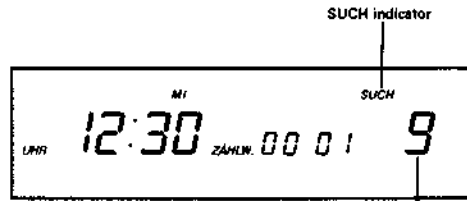
When the SUCHL. MARKE button is pressed during recording, and the normal audio input signal is muted for about 5 seconds. Because the tape continues running during this period, a non-recorded section is produced on the normal audio track.

To take the best advantage of this facility, proceed as follows:

- Press the SUCHL. MARKE button at the end of one programme.
- Press the PAUSE/STANDB. button immediately after pressing the SUCHL. MARKE button.
 - The tape will stop after a 5-second blank is produced.
 - During this 5-second period, the Symbolic mode indicators for RECORD and PAUSE will be blinking.
- Press the WIEDERGABE button to start recording of the next programme.

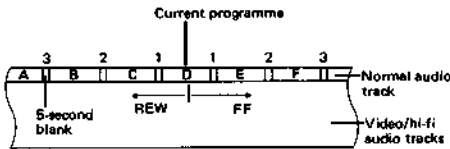
Notes:

- Because the same signal is recorded on the hi-fi and normal audio tracks simultaneously, the Music Scan function during playback is also effective in listening to the hi-fi soundtrack.
- The SUCHL. MARKE button does not function during instant recording or timer recording.



Specified number

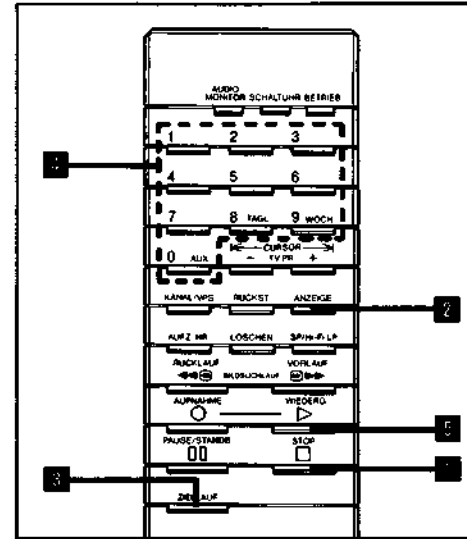
Hints for specifying a musical selection



- "1" + VORLAUF scans to the beginning of the next programme (E).
- "1" + RÜCKLAUF scans to the beginning of the current programme (D).
- "2" + RÜCKLAUF scans to the beginning of the previous programme (C).

COUNTER GO-TO FUNCTION

The counter go-to function gives you direct access to any point on the tape by simply specifying a desired counter reading. Depending on your command, the tape will either stop at that point or playback will start automatically from there.

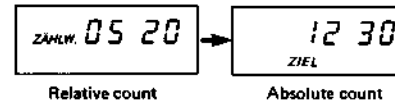


- Engage the Stop mode.
- Call up the Counter mode with the ZÄHLWERK/RE-STZ./DATUM button. (or the ANZEIGE button on the remote control)
- Press the ZIELLAUF button.

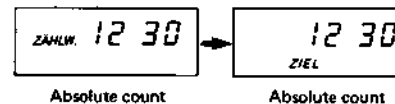
The counter will change to the go-to mode.

There are three possible cases:

- Counter reading changes from one number to another.



- Counter reading remains unchanged.



- "----" appears instead of a number.



- The recorder did not detect the leader tape when the cassette was loaded and, therefore, cannot determine the tape's present position in relation to its beginning.

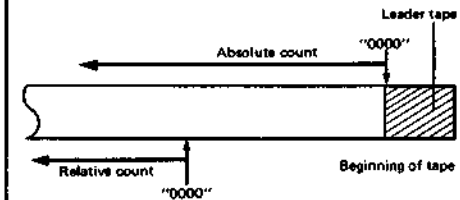
- Specify the point you want to locate by using 10 numeric keys.



- Press the WIEDERGABE (or the WIEDERG. button on the remote control) button if you want playback to start there or the STOP button if you want the tape to stop there.

- In cases (1) and (2), the tape will either fast forward or rewind to the specified point.
- In the case of (3), the tape is first rewound to the beginning of the tape (where the counter is automatically reset to "0000") and then is fast forwarded to the specified point.
- Once the beginning of the tape is detected in this way, the tape counter always reads the position in relation to the beginning until the RÜCKST. button is pressed at a different position.
- If the specified number exceeds the tape length, the tape is first fast forwarded to its end, then rewound to its beginning and stops.
- Use of the go-to function cancels the previous relative count.

Absolute count vs. Relative count



- The absolute "0000" count is automatically set when the leader tape is detected at the time of cassette loading.
- The relative "0000" count is set when the RÜCKST. button is pressed and does not apply to the counter Go-To procedure.

COUNTER MEMORY AND COUNTER/REMAIN FUNCTIONS

Counter Memory function

1. Press the ZÄHLWERK/RESTZT./DATUM button to obtain the Counter mode.
2. Press the RÜCKST. button at a point which you may wish to locate later.
 - The tape counter will indicate "0000".
3. Press the ZÄHLWERK-SPEICHER button to EIN (—).
4. Press the RÜCKLAUF (or VORLAUF) button when you need to return to the designated point. The tape will rewind (or fast forward) and stop at about the "0000" counter reading automatically.

Memory Play function

If you want playback to start automatically at the counter reading of "0000", press the WIEDERGABE button within 2 seconds after pressing the RÜCKLAUF or VORLAUF button in step 4.

ZÄHLWERK/RESTZT./DATUM button

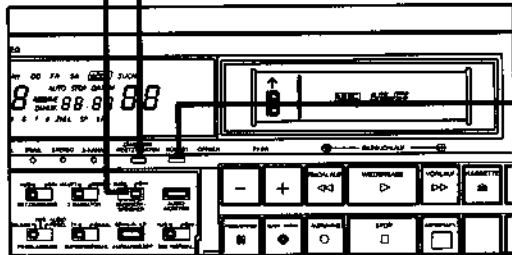
Press to change the display to tape counter (ZÄHLW.), remaining tape time (RESERVE) and date (DATUM). To use the display as the tape counter, call up the ZÄHLW. indicator. To check the length of tape left, call up the RESERVE indicator; the remaining tape length will be shown in hours and minutes. (It will take a brief period for the numerals to appear). This button can also be used to change the display from the Timer Set mode to the Clock mode.

RÜCKST. button

Press to reset the tape counter to "0000" for indexing the tape.

Note:

Unless the RÜCKST. button is pressed, the count is maintained even after the power is switched off (as long as the unit is plugged into an AC outlet).



Notes:

- During recording, the remaining tape length is calculated in reference to the recording mode selected by the SP/Hi-Fi LP button; during playback, it is calculated in reference to the recording mode of the tape being played (SP/LP).

- The indicated remaining time is approximate. The time required to calculate the remaining tape length and the accuracy of that calculation may vary according to the type of cassette tape. (The remaining time indication is not available if this mode is engaged from Fast Forward or Rewind.)

RECORDING WITH A VIDEO CAMERA

Connection

To connect a video camera, an appropriate camera adapter is necessary.

- Connect the video camera to the camera adapter.
- Connect the camera adapter to the HR-D470EG: adapter's AUDIO and VIDEO OUT to recorder's AUDIO/VIDEO, and adapter's PAUSE to recorder's PAUSE FERN-BEDIENUNG.

For proper connection of a camera to the HR-D470EG, consult a JVC dealer.

Operation

1. Turn the power on for all connected equipment.
2. Adjust the TV receiver to your video channel.
3. Load a cassette.
4. Press the "0" key of the 10-digit keypad to engage the AUX mode.
5. Press the AUFNAHME and PAUSE/STANDB. simultaneously.
 - The recorder enters the Recording Standby mode.
6. Operate the camera's start/stop switch.
 - Recording starts and stops with this switch.
7. To end of the recording, press the STOP button.


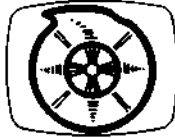
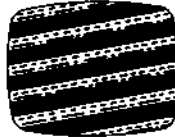


Notes:

- If feedback noise (whistling or howling) is heard from the TV receiver, reduce the volume or move the camera's microphone, farther away from the TV receiver.

- For camera operation refer to the instruction manual for the relevant camera.

ADJUST YOUR TV RECEIVER WHEN

Still Playback may require adjusting your TV receiver. If your TV receiver shows the following symptoms during Still Playback, adjust the TV receiver first.

Symptom	Adjustment
<p>Picture vibrates vertically.</p> 	<p>Turn the V-Hold knob slightly for stabilising.*</p>
<p>The upper portion of the picture drifts horizontally.</p> 	<p>Turn the H-Hold knob slightly for stabilising.**</p>
<p>Picture rolls.</p> 	<p>Turn the H-Hold knob slightly for stabilising.**</p>
<p>Picture is flattened vertically.</p> 	<p>Inherent in your TV receiver.</p>
<p>Only a portion of the picture continues to flicker.</p> 	<p>Not adjustable. Inherent in your TV receiver.</p>

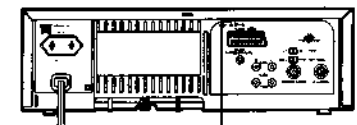
HEAD CLEANING

- Picture playback may become blurred or interrupted while the TV programme received is clear. This does not mean that the recorded programme has been erased.
- Dirt accumulated on the video heads after long periods of use causes such troubles. In this case, head cleaning requiring highly technical care is necessary.

* For head cleaning, consult the nearest JVC dealer.

If the V-Hold and H-Hold knobs are not provided on your TV receiver, please consult your JVC dealer.

Rear



V-BILDFANG control

* If an unsatisfactory result is obtained, adjust the V-BILDFANG control located on the rear panel of the HR-D470EG so that a stable picture is obtained.

** If an unsatisfactory result is obtained, it is necessary to adjust the AFC circuit of the TV receiver.

IN CASE OF DIFFICULTY

What may initially appear to be trouble is not always a real problem. Make sure first . . .

POWER AND TAPE TRANSPORT PROBLEMS

Symptoms	Check points
No power is applied to the recorder.	<ul style="list-style-type: none"> Is the power cord disconnected? – Connect it.
Clock is functioning properly, but the recorder cannot be powered.	<ul style="list-style-type: none"> Is the TIMER indicator lit on the FDP? – Press SCHALTUHR to disengage the Timer Recording Standby mode.
Tape does not run during recording.	<ul style="list-style-type: none"> Is the PAUSE/STANDB. button engaged? – Press the WIEDERGABE button.
Tape stops in the Rewind or Fast Forward mode.	<ul style="list-style-type: none"> Is the ZAHLWERK-SPEICHER button set to EIN? – Set it to AUS.
Tape will not rewind or fast forward.	<ul style="list-style-type: none"> Is the tape already fully rewound or fast forwarded? – Check the cassette.

RECORDING PROBLEMS

Symptoms	Check points
Recording cannot be started.	<ul style="list-style-type: none"> Is a cassette loaded? Is the safety tab on the cassette removed? – Re seal the slot with cellophane tape.
Camera recording is not possible.	<ul style="list-style-type: none"> Are the camera and the camera adapter correctly connected? Is the power switch of the camera adapter set to ON? Does the channel display indicate "0"? – Press \square.
Simulcast recording is not possible.	<ul style="list-style-type: none"> Is the AUFNAHMEWAHL switch set to TV? – Set it to SIMUL. Is an audio source correctly connected to the AUDIO EING. connectors? – Check connections.
Timer recording is not possible.	<ul style="list-style-type: none"> Have you set the clock correctly and programmed the timer correctly? – Check once again. Is the TIMER indicator lit on the FDP? – Press SCHALTUHR.

PLAYBACK PROBLEMS

Symptoms	Check points
Playback picture does not appear while the tape is running.	<ul style="list-style-type: none"> Is the TV receiver's channel selector set to the correct video channel? – Set it to the RF converter channel. (See page 38.)
Noise appears during playback.	<ul style="list-style-type: none"> Adjust the SPURLAGE control.
Playback picture is blurred or interrupted while TV broadcasts are clear.	<ul style="list-style-type: none"> Video heads may be dirty. – Head cleaning is necessary. Consult your nearest JVC dealer.

HI-FI AUDIO PROBLEMS

Symptoms	Check points
TV sound cannot be recorded on hi-fi audio track.	<ul style="list-style-type: none"> Is the AUFNAHMEWAHL switch set to SIMUL? – Set it to TV.
Breaks are noticeable in hi-fi audio reproduction.	<ul style="list-style-type: none"> Adjust with the SPURLAGE control. (See page 43.) Have you adjusted the recording level correctly? – Over-level recordings could be a cause. Adjust the level correctly next time. See page 43.
Soundtrack on the hi-fi audio track cannot be reproduced.	<ul style="list-style-type: none"> Does the NORMAL indicator light? – Press the AUDIO MONITOR button to Hi-Fi STEREO (or L or R as required).
Audio level indicators do not function.	<ul style="list-style-type: none"> Is the PEGELANZEIGE switch set to a position other than AUDIO PEGEL? – Set it to AUDIO PEGEL.

OTHERS

Symptoms	Check points
Whistling or howling is heard from TV.	<ul style="list-style-type: none"> Move camera or microphone away from TV or reduce TV sound volume.
Some channels are skipped over when selecting a channel.	<ul style="list-style-type: none"> Those channels are preset to be skipped over. If you need them, restore them. (See page 40.)
Channel cannot be switched.	<ul style="list-style-type: none"> Is recording in progress? – Press the PAUSE/STANDB., select a desired channel and press the WIEDERGABE.

This recorder contains microcomputers. External electronic noise or interference could cause malfunctioning. In such cases, switch the power off and unplug the power cord. Then plug it in again and switch on. Take out the cassette. After checking the cassette, operate the unit as usual.

INSTRUCTIONS: VIDEO CASSETTE RECORDER

For reference, the text of the Instruction booklet for this model is reproduced in the following pages.

Numbering of the pages also corresponds with that of the booklet.

The Instructions shown pertain specifically to the Model HR-D470EG. For detailed descriptions, be sure to consult the Instruction booklets of the other models.

Main differing points with respect to other models in this series (with suffixes E and EG) are also included.

The following table lists the principal differing points among the models (suffixes E, EG and EK) in this series.

Model		EG	E	EK
Power requirement		220 V~, 50/60 Hz	←	240 V~, 50/60 Hz
Power consumption		37 W	←	32 W
Aerial input	VHF channels	47 – 89 MHz, 104 – 300 MHz, 302 – 470 MHz	←	No
	UHF channels IV/V	470 – 862 MHz	←	CH 21 – 69
AUDIO	AUDIO/VIDEO socket	21-Pin Peri connector	←	No
VPS decoder		Yes	←	No
Sound multiplex capability		Yes	←	No

NOTE: ← Same as model at left.

SECTION 1 MECHANISM ADJUSTMENT

1.1 GENERAL

1.1.1 Precautions

IMPORTANT:

1. Disconnect unit from power before removing or soldering components.
2. When removing a fastener (screw, washer, etc.), be careful not to drop it into the mechanism. If a fastener should be dropped, be sure to retrieve it.
3. The tape transport mechanism has been precisely adjusted at the factory and ordinarily does not require readjustment.
4. When removing a part, be very careful not to damage or displace other parts. (Be especially careful with the tape guides and rotary video head drum.)
5. For service procedures that call for operation of the set with the cassette housing is separated from the main-deck, perform as below.
 - 1) Disable the photo transistor sensor (END SENSOR) on the main-deck by applying an opaque cover.
 - 2) Supply power and select required modes with front panel operation buttons.

1.1.2 Required test equipment, fixtures and tools

For proper mechanical adjustment, the following test equipment, fixtures and tools are strongly recommended. Without them, a long trial-and-error period would be necessary, resulting in possible damage. In addition, general-purpose tools are required.

1. Test equipment required:

Color television or monitor

Oscilloscope: Wide-band, dual trace, triggered, delayed sweep

Recording tape

Alignment tapes

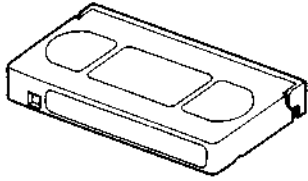
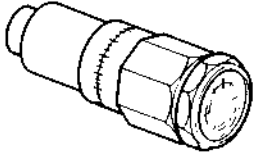
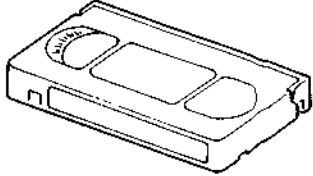
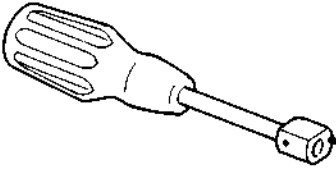
<p>JVC alignment tape MH-2/MH-F2</p> 	<p>Torque gauge assembly PUJ48075-2 (Torquemeter : 600ATG Torquemeterhead : PUJ48016-2)</p> 	<p>Back tension cassette gauge PUJ48076</p> 
<p>A/CTL head position tool PUJ47351-2</p> 		

Table 1-1-1 Fixtures and tools

1.1.3 Layout of main parts

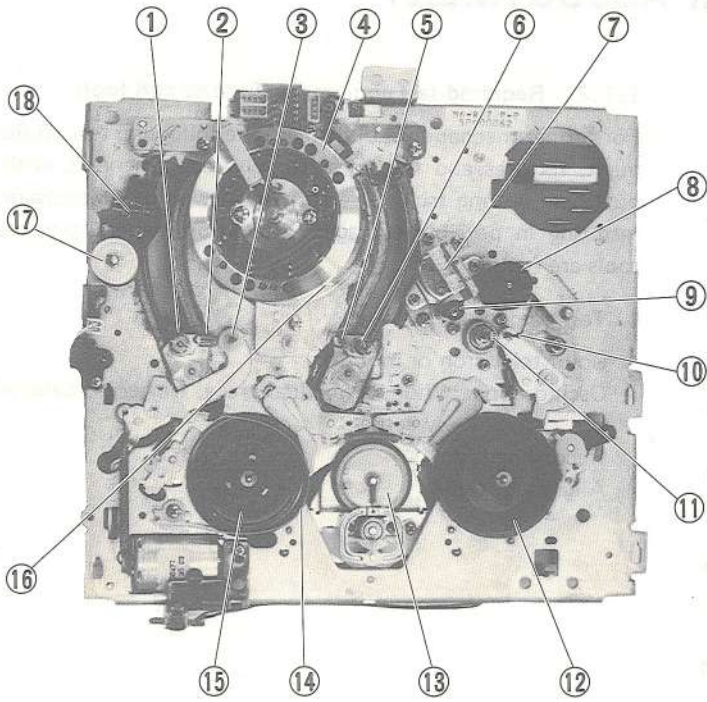


Fig. 1-1-1 Top view of main-deck

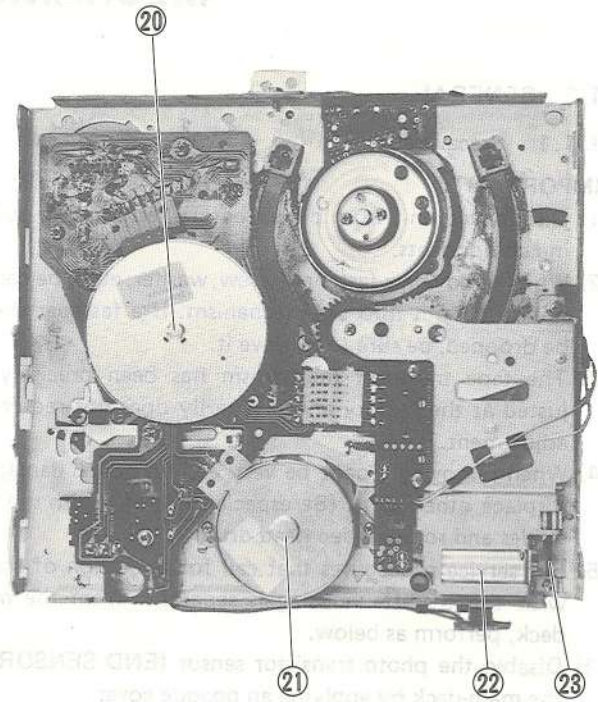


Fig. 1-1-2 Bottom view of main-deck

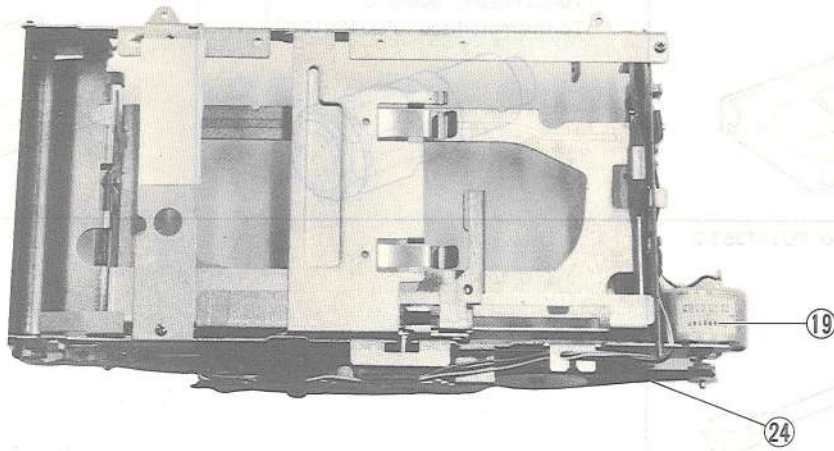


Fig. 1-1-3 Cassette housing

- | | | |
|-------------------------|-----------------------|----------------------|
| 1. Supply guide roller | 9. Take-up guide pole | 17. Impedance roller |
| 2. Supply slant pole | 10. Guide arm | 18. Full erase head |
| 3. Tension pole | 11. Capstan | 19. Cassette motor |
| 4. Upper drum | 12. Take-up reel disk | 20. Capstan motor |
| 5. Take-up slant pole | 13. Reel idler | 21. Reel motor |
| 6. Take-up guide roller | 14. Tension band | 22. Mode motor |
| 7. A/C head | 15. Supply reel disk | 23. Mode belt |
| 8. Pinch roller | 16. Lower drum | 24. Cassette belt |

1.2 MAIN ASSEMBLY REPLACEMENT

1.2.1 Upper drum assembly

Notes: When handling and installing the upper drum assembly, avoid directly touching the head tips on the upper drum assembly.

For cleaning the head tips, push and hold a lint-free cloth or chamois dampened with alcohol to the upper drum assembly by the fingers, then turn the upper drum assembly clockwise. Do not clean the upper drum assembly with a vertical stroke.

1. Removal

- 1) Take out a screw and remove the brush assembly from the drum assembly.
- 2) Unsolder all soldered portions on the DRUM PWB. Remove excess solder, then remove the DRUM PWB from the upper drum assembly.
Note: Soldered portion can be easily removed by removing solder with sucker or wick.
- 3) Take out two screws and remove the upper drum assembly upwards.

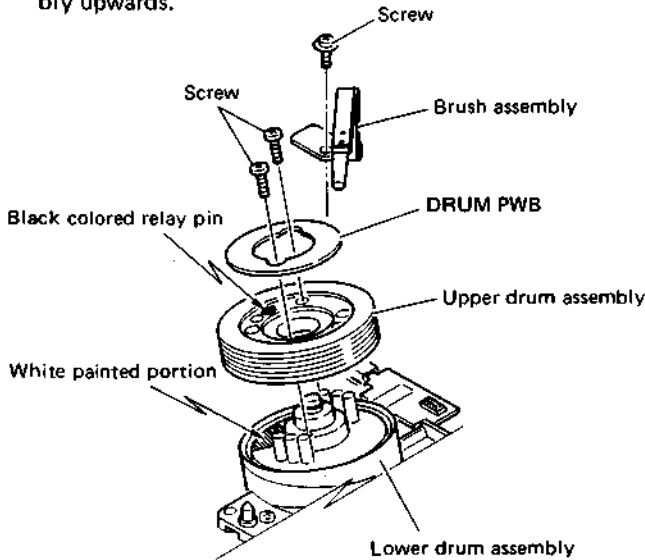


Fig. 1-2-1 Upper drum assembly

2. Installation

- 1) Install a new upper drum assembly so that the black-colored relay pin of the upper drum assembly overlies the white painted portion of the lower drum assembly, as shown in Fig. 1-2-1.
- 2) Tighten two screws in a balanced manner.
- 3) Set the DRUM PWB on the upper drum assembly, then resolder it.
- 4) Clean the drum unit (particularly clean the upper drum assembly).
- 5) Mount the brush assembly on the original position, then tighten a screw to fix the brush assembly.

3. Confirmation and adjustment

- 1) Perform the FM envelope confirmation. Refer to section 1.6.1.
- 2) Perform the PB switching point adjustment of the Servo circuit. Refer to section 2.4.1.
- 3) Perform overall confirmation of the FM audio circuit. Refer to section 2.7.

1.2.2 A/C head (Audio/control head)

1. Removal

- 1) Disconnect connectors from the A/C HEAD PWB.
- 2) Take out two screws, then remove the A/C head and the head base together.
- 3) Unsolder and separate the A/C HEAD PWB from the A/C head.
- 4) Take out a screw and remove the shield cap from the A/C head.
- 5) Take out three screws and separate the A/C head from the head base. Use care regarding springs. Do not lose them.

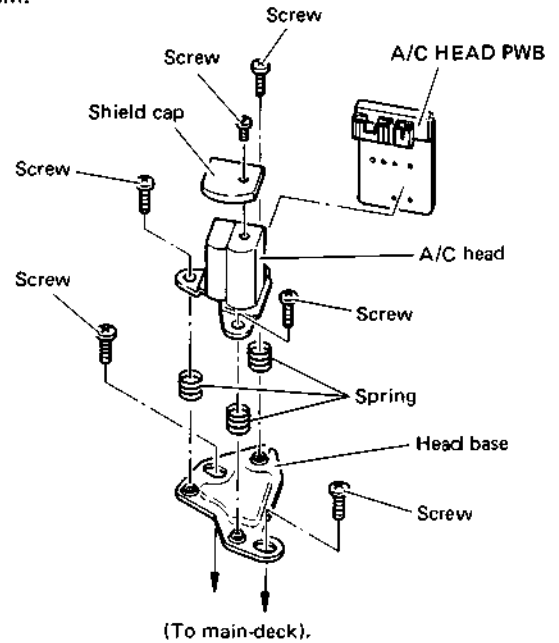


Fig. 1-2-2 A/C head

2. Installation

- 1) Mount a new A/C head and other peripheral parts on the main-deck by reversing the removal procedure.
- 2) Before installing the A/C head on the main-deck, perform rough-adjustment of A/C head height as shown in Fig. 1-2-3.

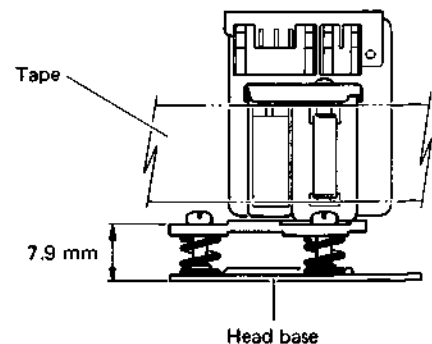


Fig. 1-2-3 A/C head height

3. Confirmation and adjustment

- 1) Use a recording tape and confirm correct tape transport operation, then perform interchangeability adjustment. Refer to sections 1.5 and 1.6.
- 2) Perform overall confirmation of the Audio circuit. Refer to section 2.6.

1.2.3 Tension band assembly

1. Removal

- 1) Take out a screw, then pry the A portion of the tension band assembly upwards to separate it from the tension arm assembly.

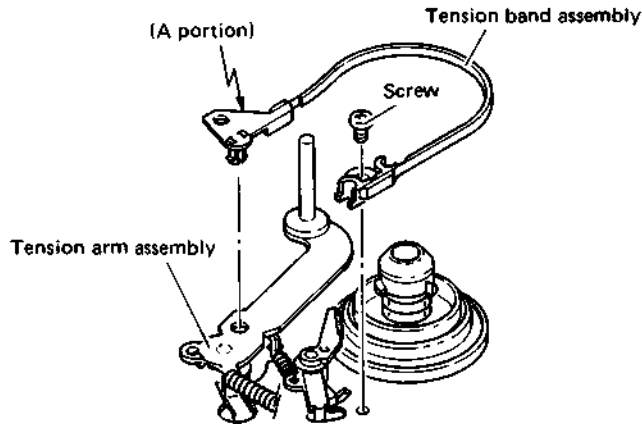


Fig. 1-2-4 Tension band assembly

2. Installation

- 1) Install a new tension band assembly by reversing the removal procedure.

3. Confirmation and adjustment

- 1) Perform tension pole position adjustment. Refer to section 1.4.1.

1.3 ASSEMBLY PROCEDURE OF MECHANISM

The mechanism of this model is mostly engaged to the mechanism control circuit, through the mode select switch. Therefore, the relation between the mode select switch and the control arm decides all mechanical movement of the mechanical parts such as levers, gears, rollers and so on. If these parts are not properly positioned, the unit will be unloaded or compulsorily stopped. This will result in damage of mechanical or electrical parts.

1.3.1 Loading arm assembly

Loading arm assembly consists of loading gear, torsion spring and loading arm.

1. Set up the loading arm assembly correctly as shown in Fig. 1-3-1.

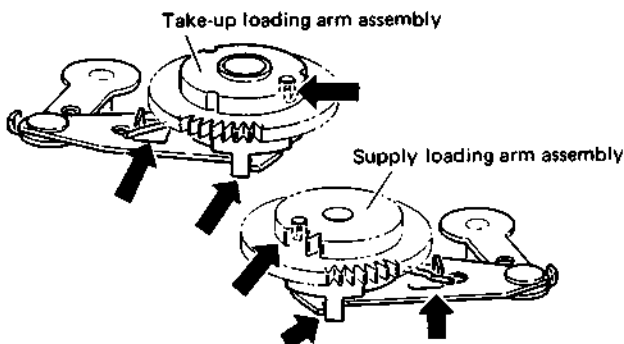


Fig. 1-3-1 Loading arm assembly (1)

2. Install the take-up loading arm assembly and the supply loading arm assembly so that the holes on the loading gears face each other, as shown in Fig. 1-3-2. Do not move the loading arm assemblies from this position for the next step.

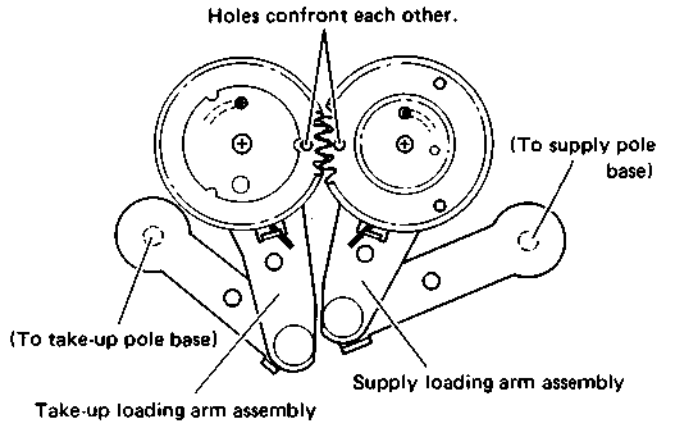


Fig. 1-3-2 Loading arm assembly (2)

1.3.2 Control cam

1. Set the arm gear assembly on the cam bracket assembly so that the hole of the arm gear assembly overlaps the hole of the cam bracket assembly.
2. Install the control cam on the cam bracket assembly so that the hole of the control cam overlaps the hole which is indicated in the step 1), as shown in Fig. 1-3-3. Do not turn the control cam from this position for the next step.

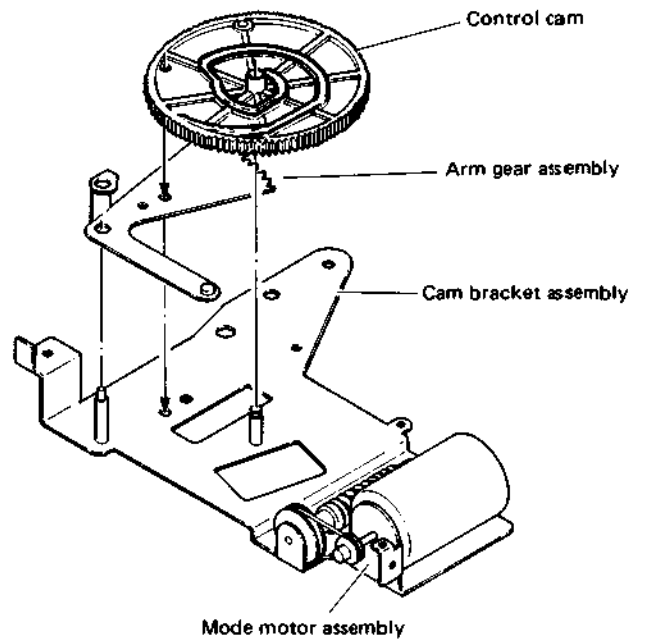


Fig. 1-3-3 Control cam

1.3.3 Cam bracket assembly

1. Push and hold the plate assembly so that the hole of the plate assembly overlaps the hole of the main-deck, as shown in Fig. 1-3-4.
2. Then mount the cam bracket assembly.

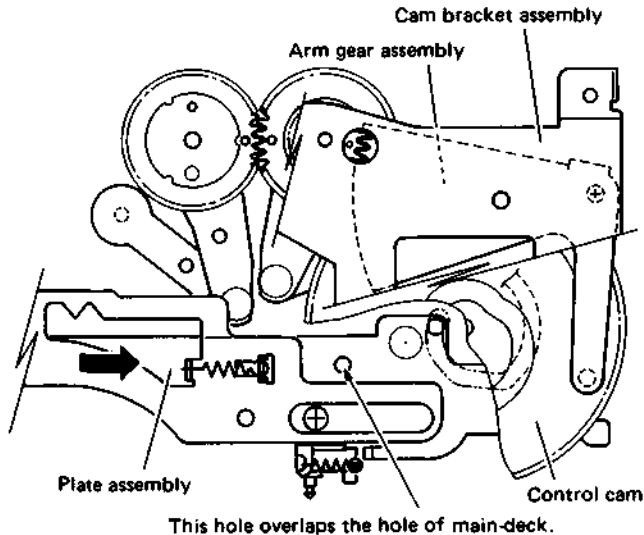


Fig. 1-3-4 Cam bracket assembly

1.4 CONFIRMATION AND ADJUSTMENT

1.4.1 Tension pole position adjustment

1. Without loading a tape, set for the Play mode.
2. Loosen screw a little bit, then adjust the tension band holder so that the distance, shown in Fig. 1-4-1, becomes zero (0 mm).
3. Tighten screw to fix the tension band holder.

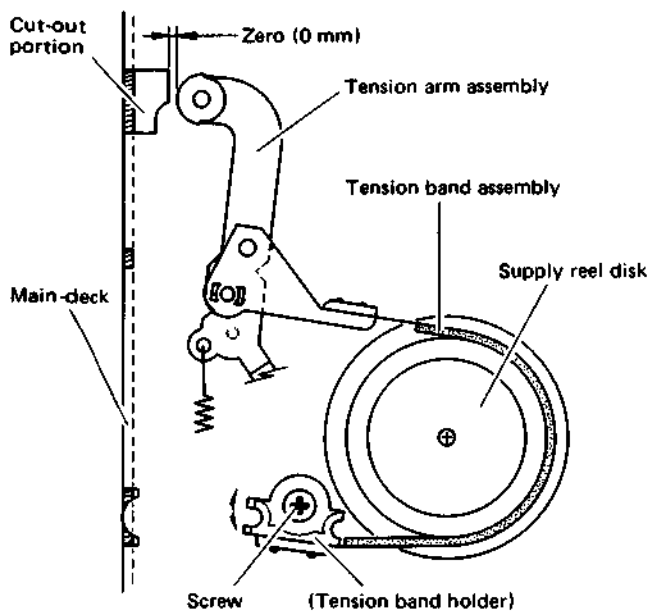


Fig. 1-4-1 Tension pole position

Note: By this adjustment, back tension is within normal specification, in spite of parts tolerances.

4. Use the back tension cassette gauge and set for the Play mode.
5. Confirm that the indication is between 26–46.

1.4.2 Take-up torque confirmation

1. Set the Play mode without the cassette housing assembly.
2. Set the torque gauge on the take-up reel disk.
3. The torque gauge consists of upper and lower sections connected by a spring mechanism. Relax the grip on the torque gauge so that the indicator needle and scale rotate at equal speed, then read the indication. The correct value is between 45–155.
4. If necessary, replace the take-up and supply clutches.

1.5 TAPE TRANSPORT SYSTEM CONFIRMATION AND ADJUSTMENT

Once adjusted to the complete condition, readjustment of the tape transport system is not necessary, except when the parts that compose the tape transport system are replaced due to troubles by long usage or unexpected accidents.

1.5.1 Tape transport system adjustment

1. Guide roller

To get the FM envelope into ideal shape for interchangeability, the height adjustment of the guide roller is needed.

Before turning the guide roller, slightly loosen the setscrew located under the guide roller. For loosening the setscrew, use the hex key (1.25 mm).

Note: Loosen the setscrew enough to allow the guide roller to be turned. If excessively loose, tape motion may turn the guide roller inadvertently.

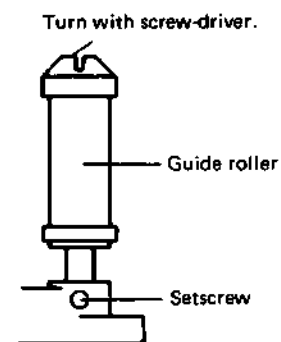


Fig. 1-5-1 Guide roller

2. Impedance roller

Normally, do not adjust the height of the impedance roller. Only when the defects of tape travel are noted at the impedance roller, after complete adjustment for interchangeability, adjust the height of impedance roller to obtain smooth tape travel. For adjustment of impedance roller height, use the nut-driver (5.5 mm).

Note: Do not lower the impedance roller excessively to avoid the defects of tape travel. Tape must be along the lower flange located under the impedance roller.

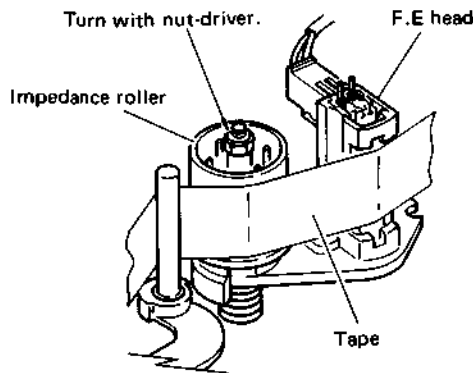


Fig. 1-5-2 Impedance roller

3. A/C head (audio/control head)

When defects of tape travel are noted at the take-up guide pole, adjust the inclination of A/C head to obtain smooth tape travel.

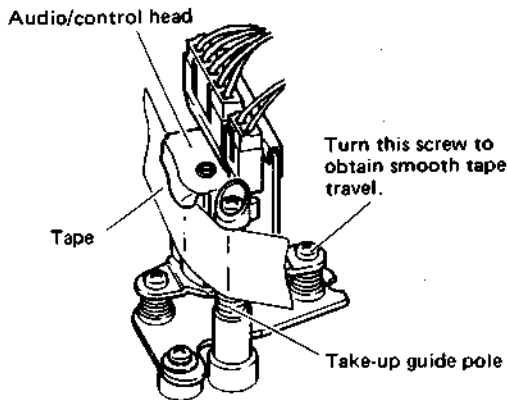


Fig. 1-5-3 A/C head

1.6 INTERCHANGEABILITY CHECKS AND ADJUSTMENT

Before using costly Alignment tape, use a spare cassette and confirm proper tape transport without damage to the tape.

1.6.1 FM waveform

The FM waveform checks and adjustments are performed using the staircase signal of the **MH-2** Alignment tape. Connect an oscilloscope to the FM output test point of the video play-back circuit and trigger the oscilloscope externally with the signal from the flipflop (FF) test point of the video circuit.

1. Play the **MH-2** Alignment tape and adjust the tracking for maximum FM output. With the maximum taken as (a), the minimum center output as (b), the minimum at the drum input as (c) and the minimum at the drum output as (d), confirm the following relationship.

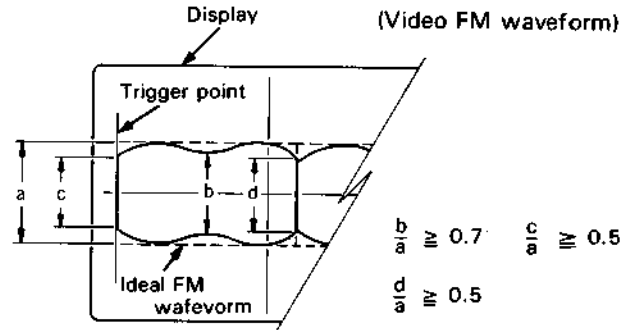


Fig. 1-6-1 FM waveform

2. Adjustment is required if the waveform does not meet the above specifications and also if overall variation of the FM waveform is not linear. In this latter case, proportional level decline would occur with even slight tracking deviation to produce noise in the picture.
3. Operate the tracking control and vary the FM waveform from maximum to minimum, then from minimum to maximum. Observe the waveform portion corresponding to the drum input and confirm essentially parallel variation. However, if the variation is in a see-saw pattern, the supply guide roller height requires adjustment.

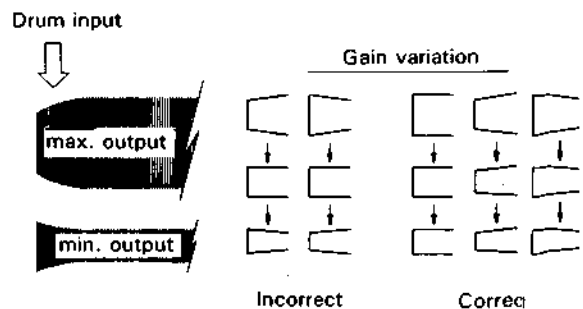


Fig. 1-6-2 Input FM waveform

In other words, the tape is not properly following the drum lead at the drum input side. Adjust the supply guide roller height so that the variation is as parallel as possible.

4. Similarly, observe the FM waveform portion corresponding to the drum output and if necessary, adjust the take-up guide roller height so that the variation is as parallel as possible.

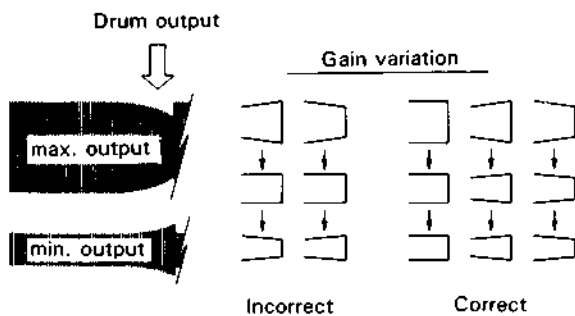


Fig. 1-6-3 Output FM waveform

5. Next, observe the entire FM waveform. So that the overall variation is as parallel and linear as possible, carefully adjust both guide rollers.

6. After adjusting the guide rollers, check for absence of tape wrinkles or creases at the take-up and supply guide poles. If these are observed at the supply guide pole, adjust the guide pole height with attention to the tape transport at the lower flange of the pole. Perform carefully, since this affects the FM waveform risetime. If wrinkles or creases are observed at the take-up guide pole, adjust the audio/control head inclination (some recent models do not have adjustable take-up guide poles) with attention to the tape transport at the lower flange of the pole.

Afterwards, again check the FM waveform.

1.6.2 Audio/control head adjustment

Incorrect position of the audio/control head reduces the play-back audio output, impairs S/N and in severe cases, interferes with servo stability due to inability to pickup the control signal.

Observe the audio signal waveform by connecting an oscilloscope to the audio output test point of the audio circuit or directly to the audio output terminal. In some cases, connecting headphones and directly listening to the sound forms a useful test.

1. Play the stairstep (audio 6 kHz) section of the **MH-2** Alignment tape.
2. Adjust the azimuth by turning screw ③ for maximum audio output.

3. Adjust the height by turning screws ①, ② and ③ by small and equal increments (about 45°) at a time for maximum audio output. For ("Normal") stereo models, also adjust for balanced outputs from the right and left channels.

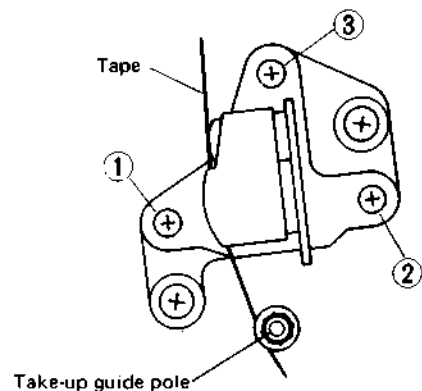


Fig. 1-6-4 A/CTL head adjustment

4. For stereo models, also play the color bar (audio 1 kHz) section of the **MH-2** Alignment tape and adjust to eliminate phase difference between the right and left channels.

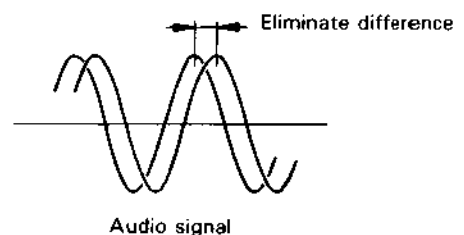


Fig. 1-6-5 Audio phase

5. Again check the FM waveform. If acceptable, carefully tighten the setscrews of the guide rollers. Since this may disturb the FM waveform, check again after tightening the screws.

1.6.3 Control head phase (X Value)

Incorrect adjustment of the X value can cause a time difference between picture and sound play-back. This is more likely to be noticed in the LP mode than the SP mode.

Observe the FM waveform by connecting an oscilloscope to the FM output test point of the video circuit. Trigger the oscilloscope externally with the flipflop signal and set the slope to minus (-) to observe the CH1 waveform. Set the tracking control to the center click (AUTO) position.

1. Play the stairstep section of the **MH-2** Alignment tape.
2. Slightly loosen screws ④ and ⑤ of the audio/control head. Place the A/CTL head positioning tool over screw ④ with the pin of the tool inserted in the adjustment hole near the screw.
3. Turn the tool counter-clockwise to position the audio/control head fully toward the capstan side.
4. Gradually turn the tool clockwise while observing the CH1 FM waveform. At the first output peak, stop turning and immediately tighten screw ⑤. Then tighten screw ④.

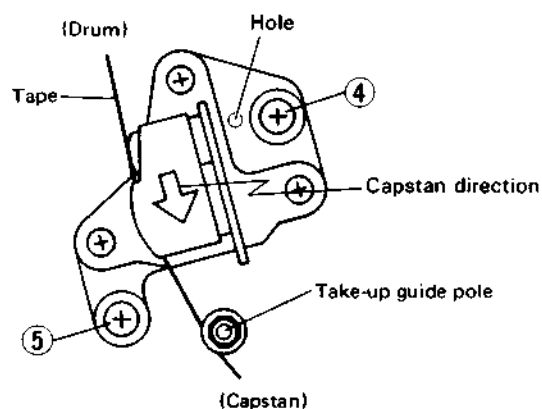


Fig. 1-6-6 Control head phase

5. Operate the tracking control and confirm that maximum FM waveform is obtained at the center click position.

1.6.4 Final checks

1. Supply a video or TV signal input, record and play-back. Confirm that the FM waveform conforms to the video FM waveform specifications (SP and LP modes).
2. For VHS Hi-Fi models, connect an oscilloscope to the audio FM output of the FM audio play-back circuit. Play the FM audio signal (carrier only) of the **MH-F2** Alignment tape. Confirm absence of serious dips in the FM waveform.
3. Refer to Electrical Adjustments and perform overall checks and adjustments of the servo, video and audio (including FM audio) circuits.

SECTION 2 ELECTRICAL ADJUSTMENTS

2.1 PREPARATION

Electrical adjustments are required after replacing circuit components and certain mechanical parts.

It is important to perform these adjustments only after all repairs and replacements have been completed. Also, do not attempt these adjustments unless the proper equipment is available.

2.1.1 Required test equipment

1. Colour television or monitor
2. Oscilloscope: wide-band, dual-trace, triggered delayed sweep
3. Frequency counter
4. Audio oscillator
5. Audio voltmeter
6. Digital voltmeter
7. Signal generator: RF/IF sweep/marker
8. Signal generator: PAL colour bar, stairstep
9. Recording tape
10. Alignment tapes: (MH-2, MH-F2)

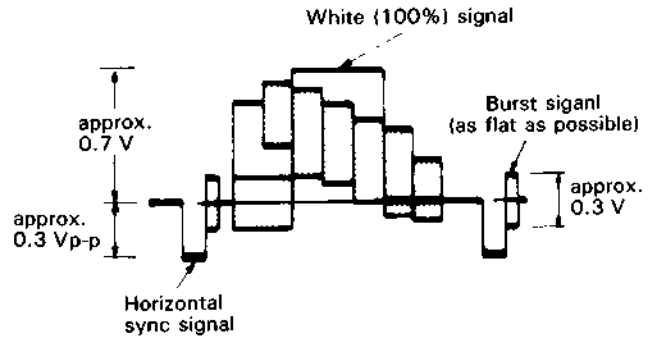


Fig. 2-1-1 Colour bar signal of pattern generator

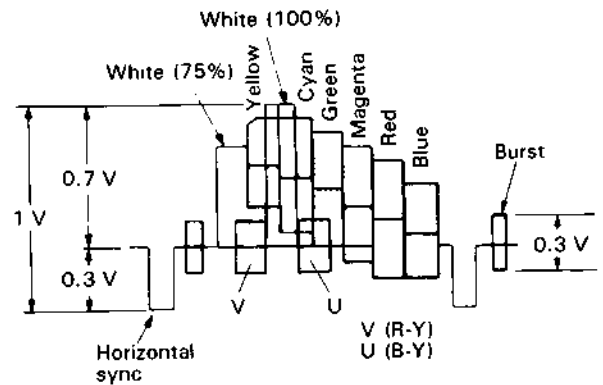


Fig. 2-1-2 Colour bar signal waveform

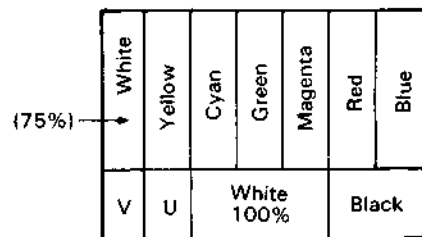


Fig. 2-1-3 Colour bar pattern

2.1.2 Check and adjustment steps

The check and adjustment steps are provided in the following in the form of charts. For clarity, the nomenclature used in the charts is outlined below.

No.	Checks and adjustments are numbered in the recommended sequence in which they are to be performed.
Item	Name assigned to the particular check and adjustment step.
Check Point	Location to which measuring instrument (oscilloscope unless otherwise noted) is to be connected.
Adjustment Parts	Variable component (resistor, capacitor, etc.) to be adjusted in this step. Dash (–) indicates check only.
Signal & Mode	<ul style="list-style-type: none"> • Input signal required to perform adjustment. Dash (–) indicates that special signal is not required. • Equipment operating mode at time of check or adjustment.
Colour bar	Colour bar signal as video input.
Stairstep	Stairstep signal as video input.
1 kHz	Supply a 1 kHz sinewave as audio input signal.
MH-2 Colour bar	Play colour bar segment of MH-2 alignment tape.
MH-2 Stairstep	Play stairstep segment of MH-2 alignment tape.
MH-2 1 kHz	Play 1 kHz audio signal segment of MH-2 alignment tape.
MH-2 RF sweep	Play RF sweep segment of MH-2 alignment tape.
Stop	Power on and machine in Stop mode.
REC	Recording mode
PB	Playback mode
REC ↓	Use blank tape, record, then play back in the mode specified.
(another mode)	
Search	Search (FWDS and REVS) playback mode.
Slow	Slow motion playback mode.
Still	Playback then Pause.
A DUB	Audio dubbing mode.
Description and Waveform	This column provides an explanation of the step, notes, adjustment values and waveform diagrams.

2.2 REGULATOR CIRCUIT (0 2 REGULATOR board)

Note: Unless otherwise specified, test points and variable resistors are located on the REGULATOR board.

No.	Item	Chick Point	Adjustment Parts	Signal & Mode	Description and Waveform
1	SWD 5.33 V DC Output Voltage	TP2	R15 (5.33 V DC)	REC (TUNER mode)	1. Connect the digital voltmeter to TP2 and TP4 GND. 2. Adjust R15 for 5.33 ± 0.05 V.
2	UNSW 12 V DC Output Voltage	TP1	R6 (12 V DC)	REC (TUNER mode)	1. Connect the digital voltmeter to TP1 and TP3 GND. 2. Adjust R6 for 12.2 ± 0.1 V.

2.3 TIMER CIRCUIT (2 1 FRONT board)

Note: Unless otherwise specified, test points and variable resistors are located on the TIMER board.

1	Timer Clock	TP2 (OSC)	C3 (TIMER CLOCK)	E-E	1. Connect the frequency counter to TP2 (OSC OUT) and GND. 2. Short GND and TP1 (TEST). Then short the leads of electrolytic capacitor C10 once in order to reset IC1. 3. Adjust C3 for $2048.010 \text{ Hz} \pm 0.002 \text{ Hz}$. Note: 1) Resetting IC1 while TP1 and GND are shorted provides the TEST mode.
---	-------------	--------------	------------------------	-----	--

2.4 SERVO CIRCUIT (0 3 V/M/S board)

Note: Unless otherwise specified, test points and variable resistors are located on the V/M/S board.

1	PB Switching Point	TP410 (VIDEO OUT) or CN406, pin 3	R27 (PB SW POINT)	<ul style="list-style-type: none"> • PB • MH-2 Stairstep • Trigger slope (–) • SP 	1. Connect an oscilloscope to TP410 or CN406 pin 3 of the V/M/S board. 2. Play back the stairstep segment of MH-2 alignment tape. 3. Trigger the oscilloscope externally (– slope) with the signal from TP11 SERVO board (DRUM FF). 4. Adjust R27 to position the trigger point 6.5 ± 0.5 H from V. sync.
---	--------------------------	---	-------------------------	---	--

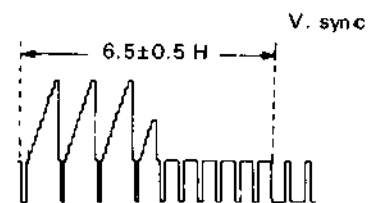


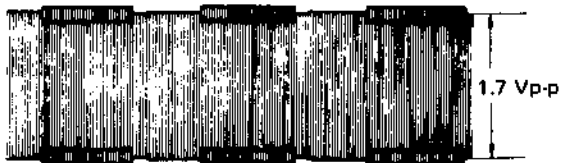

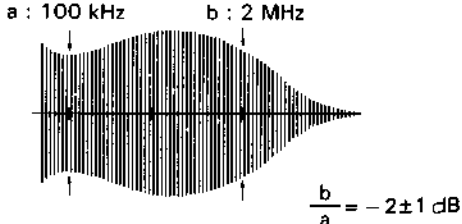
Fig. 2-4-1

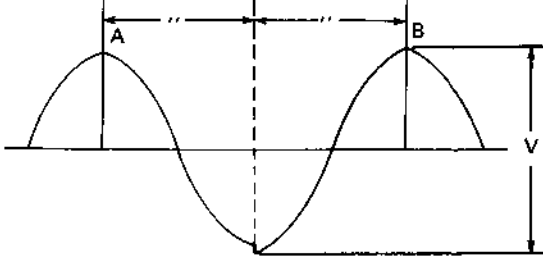
Note: Before this adjustment "Control head phase adjustment" must be completed.

2	V. Pulse Position	MONITOR	R29 (V-LOCK)	<ul style="list-style-type: none"> • Still • REC then PB • Colour bar • SP 	1. Record the colour bar signal, then playback. 2. In the Still mode, observe the monitor and adjust R29 for the minimum vertical jitter.
---	----------------------	---------	-----------------	--	--

2.5 VIDEO CIRCUIT (03 V/M/S board)

Note: Unless otherwise specified, test points and variable resistors are located on the V/M/S board.

No.	Item	Chick Point	Adjustment Parts	Signal & Mode	Description and Waveform
1	VXO	TP106 (FSC)	R117 (VXO)	<ul style="list-style-type: none"> •PB •MH-2 Colour bar •SP 	<ol style="list-style-type: none"> 1. Connect a frequency counter to TP106. 2. Playback the colour bar segment of MH-2 alignment tape. 3. Adjust R117 for 4.433619 MHz \pm 50 Hz.
2	SP REC FM Level	TP402 (REC FM)	R436 (SP REC FM LEVEL)	<ul style="list-style-type: none"> •Colour bar •REC •SP mode 	<ol style="list-style-type: none"> 1. Supply a colour bar input signal. 2. Connect an oscilloscope to TP402. 3. Adjust R436 so that the pedestal level of the vertical blanking component becomes 1.7 Vp-p. <div style="text-align: center;">  <p>Fig. 2-5-1</p> </div>
3	REC Colour Level	TP104 (PB COL)	R110 (REC COLOUR LEVEL)	<ul style="list-style-type: none"> •PB •SP mode •REC then PB •Colour bar 	<ol style="list-style-type: none"> 1. Connect an oscilloscope to TP104 playback a colour bar segment of the MH-2 and observe colour signal level. 2. Adjust the Tracking control (R401) of the FRONT board for maximum level of the colour waveform and make a note of the higher colour level. 3. Set the Tracking control (R401) to the center detent position. 4. Record the colour bar signal, then playback. Before recording, adjust R110 so that the higher level channel becomes 95 to 105% of the noted level during playback. At this time, confirm that the channel difference is within 3 dB. <div style="text-align: center;">  <p>Fig. 2-5-2</p> </div>
4	PB Frequency response	TP410 (VIDEO OUT)	R416 (FREQ RESPONSE)	<ul style="list-style-type: none"> •Video Sweep •REC ↓ •PB 	<ol style="list-style-type: none"> 1. Connect an oscilloscope to TP410. 2. Set the Sharpness control of the FRONT board to center detent position. 3. Record and playback a video sweep (with sync) signal. 4. Adjust R416 so that the 2 MHz level become 0 ± 1 dB (70 – 96%) with reference to 100 kHz. <div style="text-align: center;">  <p>Fig. 2-5-3</p> </div>

No.	Item	Chick Point	Adjustment Parts	Signal & Mode	Description and Waveform
5	SECAM DET (E/EG Models)	TP110 (SDET ADJ)	L111 (1/2 Fh TUNING) R148 (SECAM DETECTOR)	<ul style="list-style-type: none"> •SECAM colour bar •E-E <ul style="list-style-type: none"> •REC → PB 	<ol style="list-style-type: none"> 1. Connect an oscilloscope to TP110. 2. Adjust L111 so that transition step becomes centered between "A" and "B" as shown in Fig. 2-5-4.  <p>Set this point to center position between points "A" and "B".</p> <p>$V = \text{more than } 5.5 \text{ Vp-p in REC}$ $V = 6.0 \pm 0.5 \text{ Vp-p in PB}$</p> <p>Fig. 2-5-4</p> <ol style="list-style-type: none"> 3. Record then playback. 4. Adjust R148 for $6.0 \pm 0.5 \text{ Vp-p}$.

2.6 AUDIO CIRCUIT (09 AUDIO (FM/NOR) board)

Note: Unless otherwise specified, test points and variable resistors are located on the AUDIO board.

1	Audio Bias Level (LEVEL)	TP2 (BIAS LEVEL)	R128 (BIAS LEVEL)	<ul style="list-style-type: none"> •REC •SP 	<ol style="list-style-type: none"> 1. Connect a digital voltmeter between TP2 and TP1 (GND). 2. Set for REC mode without signal. 3. Adjust R128 for $2.65 \text{ mV} \pm 0.2 \text{ mVrms}$.
2	Audio PB Level	AUDIO OUT	R120 (NOR PB LEVEL)	<ul style="list-style-type: none"> •REC then PB •SP •LP •INPUL SEL: SC mode 	<ol style="list-style-type: none"> 1. Connect a oscilloscope to AUDIO OUT. 2. Supply an audio signal (-20 dBs/1 kHz at RCA Jack) to AUDIO IN and record together with a VIDEO signal, then playback. 3. Adjust R120 so that the audio output level during playback becomes $-6 \pm 1 \text{ dBs}$ for SP mode. 4. In LP mode, confirm that the audio output level during playback becomes $-6 \pm 2 \text{ dBs}$.


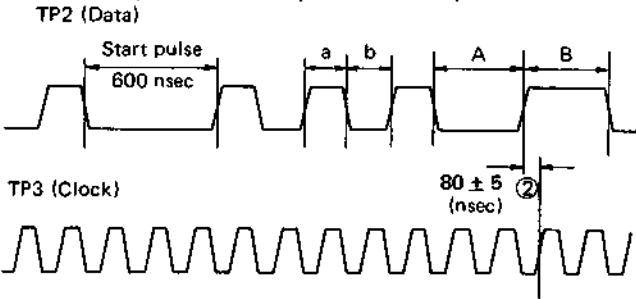
2.7 FM AUDIO CIRCUIT (09 AUDIO (FM/NOR) board)

Note: Unless otherwise noted, test and adjustment points are located on the 09 AUDIO (FM/NOR) board.

No.	Item	Chick Point	Adjustment Parts	Signal & Mode	Description and Waveform
1	FM Carrier	TP3	R89 (fo, L-CH) R95 (fo, R-CH)	<ul style="list-style-type: none"> • No signal • REC 	<ol style="list-style-type: none"> 1. Connect a frequency counter to TP3 and adjust R89 (fo, L-CH) to obtain frequency of 1.4 MHz \pm 5 kHz. 2. Connect the frequency counter to TP3 and adjust R95 (fo, R-CH) to obtain frequency of 1.8 MHz \pm 5 kHz.
2	REC FM Level	TP3	R54 (REC FM)	<ul style="list-style-type: none"> • No signal • REC 	<ol style="list-style-type: none"> 1. Without audio input signal, set for the REC mode. 2. Connect the oscilloscope to TP3 and adjust R54 to obtain 2.3 Vp-p \pm 0.1 V.
3	E-E Level	AUDIO OUT (RCA Jack)	R148 (E-E, L-CH) R147 (E-E, R-CH)	<ul style="list-style-type: none"> • E-E • Input: External • 1 kHz, -20 dBs (RCA Jack) • Audio Monitor: Hi-Fi Stereo • INPUT SEL: SC mode 	<ol style="list-style-type: none"> 1. Supply 1 kHz, -20 dBs signals to the audio inputs (both channels). 2. Set the Hi-Fi REC level control of the FRONT board to center detent position. 3. Adjust R148 (L-CH) and R147 (R-CH) to obtain -6 ± 0.5 dBs at the audio outputs, respectively.
4	PB Level	AUDIO OUT (RCA Jack)	R103 (PB LEVEL, L-CH) R107 (PB LEVEL, R-CH)	<ul style="list-style-type: none"> • PB • Audio Monitor: Hi-Fi Stereo • MH-F2: 1 kHz 	<ol style="list-style-type: none"> 1. Play 1 kHz \pm 50 kHz deviation signal of MH-F2 alignment tape. 2. Adjust R103 (L-CH) and R107 (R-CH) to obtain -6 ± 0.5 dBs audio output levels.
5	Level Indicators	FDP	R32 (IND, L-CH) R39 (IND, R-CH)	<ul style="list-style-type: none"> • E-E • Input: External • 1 kHz, -20 dBs (RCA Jack) • Stop mode 	<ol style="list-style-type: none"> 1. Supply 1 kHz, -20 dBs signals to the audio inputs (both channels). 2. Set the LEVEL IND. switch to AUDIO LEVEL. 3. In the E-E mode, adjust the front panel Hi-Fi REC LEVEL controls for -6 ± 0.5 dBs audio output levels. 4. Adjust R32 to where the FDP level indicators shown 0 dB (all white LEDs light). 5. In the same manner, adjust R39 for the R (CH2) channel.

2.8 VPS CIRCUIT (18 VPS board: E/EG models only)

Note: Unless otherwise specified, test points and variable resistors are located on the VPS board.

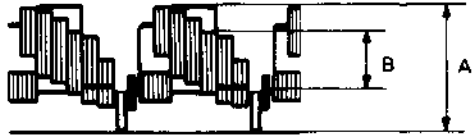
No.	Item	Chick Point	Adjustment Parts	Signal & Mode	Description and Waveform
1	Oscillator	TP6	T1 (OSC)	<ul style="list-style-type: none"> • VIDEO Sweep • Input level: 2 Vp-p 	<ol style="list-style-type: none"> 1. Connect TP5 to VDD (+5 V) and TP4 to ground. 2. Observe the TP6 waveform on an oscilloscope. 3. Adjust the inner core of coil T1 so that maximum (peak) appears as shown by ① in the figure.  <p style="text-align: center;">Fig. 2-8-1</p>
2	DUTY Check	TP2 (DATA) TP3 (CLOCK)	—	<ul style="list-style-type: none"> • VIDEO Sweep • Input Level : 2 Vp-p 	<ol style="list-style-type: none"> 1. Refer to the figure and check that <ul style="list-style-type: none"> a : b = 200 ± 10 (nsec) : 200 ∓ 10 (nsec) A : B = 400 ± 20 (nsec) : 400 ∓ 20 (nsec) The start pulse is positioned ahead of the data and is 600 nsec only at this point.  <p style="text-align: center;">Fig. 2-8-2</p>
3	Timing	TP2 TP3	T1 (Timing)	<ul style="list-style-type: none"> • VIDEO Sweep • Input level : 2 Vp-p 	<ul style="list-style-type: none"> -Adjust T1 so that time between data rise and clock rise (② in Figure 2-8-2) is 80 ± 5 nsec.

2.9 TUNER/IF CIRCUIT (07 TUNER/IF board)

Note: Unless otherwise specified, test points and variable resistors are located on the TUNER/IF board.

No.	Item	Check Point	Adjustment Parts	Signal & Mode	Description and Waveform
<p>Equipment required.</p> <ol style="list-style-type: none"> Oscilloscope IF sweep signal generator with suitable markers (PIF, SIF, etc.) DC power supplies — For power bias (12.0 V) for IF AGC bias (approx. 5 V variable) Sweeper probe (seep signal supply cable) as shown below. 					
<p>Fig. 2-9-1</p>					

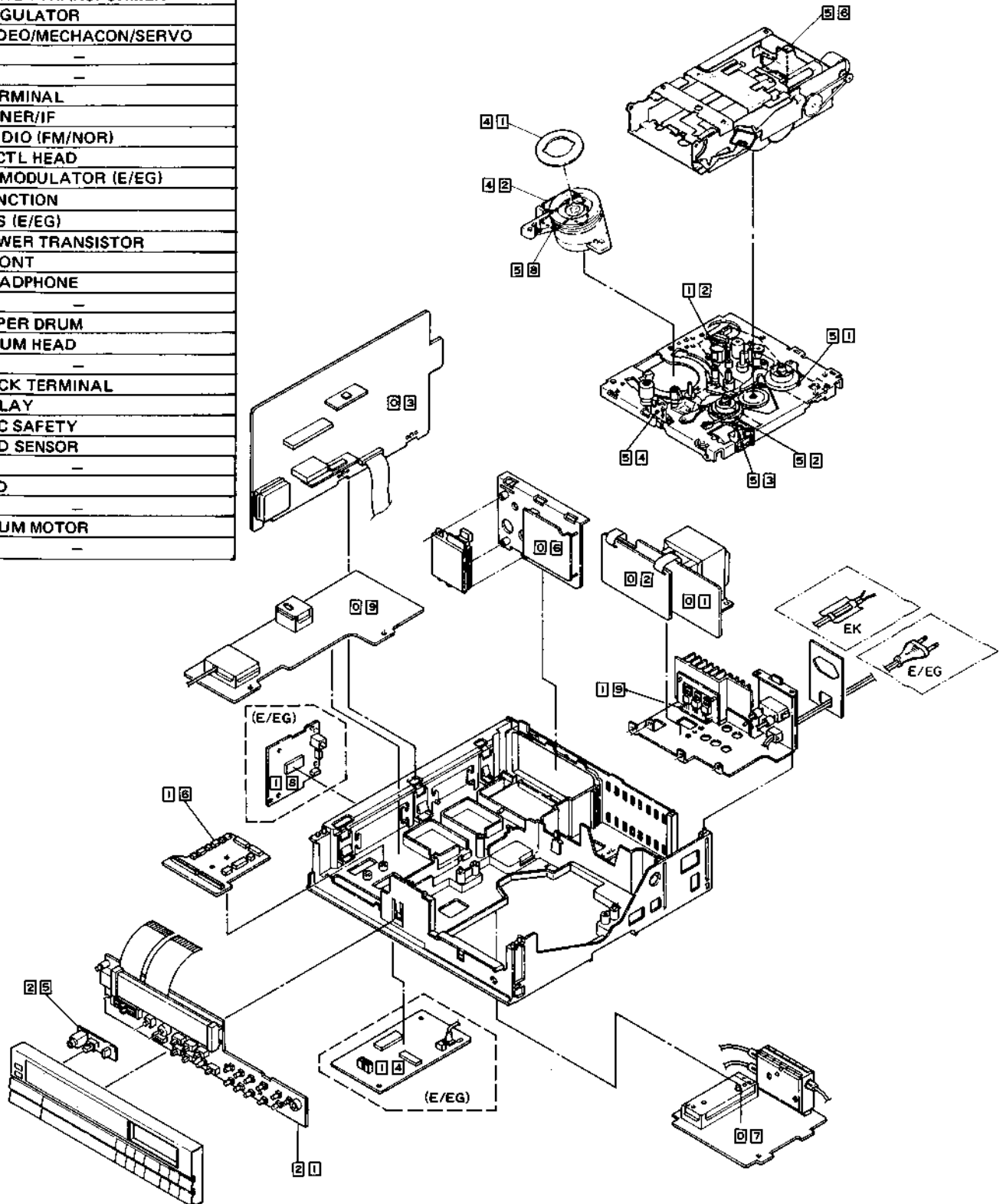
1.	VCO E/EG 38.9MHz EK 39.5MHz	IC1, pin 28	T2 (VCO)	<ul style="list-style-type: none"> Sweep Generator 	<ol style="list-style-type: none"> Use the probe shown in the figure (for IF adjustment) and connect IF sweep signal to the SAW 1 input terminal. Apply DC 4.5 V to pin 6 of IC1 (IF AGC). Connect oscilloscope to pin 28 (VIDEO DET OUT) and adjust T2 to align the waveform with the frequency marker indicated at left. <p>Note: Sweep generator output level is 70 dBμ/75 Ω.</p> <div style="text-align: center;"> <p>VCO and sweep signal</p> </div> <p>Fig. 2-9-2</p>
2.	Front End IF E/EG 38.15MHz EK 39.5MHz	TUNER (Inside the tuner unit)	IF Coil	<ul style="list-style-type: none"> Sweep Generator 	<ol style="list-style-type: none"> Use the IF adjustment probe to connect the IF sweep signal to the front-end (TUNER) test point (TP). Use the IF adjustment probe to connect the SAW 1 input terminal with the IF detector. Adjust the IF core of the front end for maximum frequency.
3	FTZ Trap (E/EG only)	IC1, pin 28	T1 (FTZ TRAP)	<ul style="list-style-type: none"> Colour Bar 	<ol style="list-style-type: none"> Supply a 32.4 MHz with 400 Hz AM modulation signal to the Tuner TP. Connect oscilloscope to pin 28 of IC1 and adjust the output side core of T1 for minimum level.

No.	Item	Check Point	Adjustment Parts	Signal & Mode	Description and Waveform
4	RF AGC	IF terminal	R11 (RF AGC)	• Colour Bar	<ol style="list-style-type: none"> 1. Receive a colour bar signal and connect oscilloscope to the front end IF terminal. 2. Adjust R11 for maximum level. Then again turn R11 to reduce the level by 10 dB.
5	VPS Y Level (E/EG only)	CN4, pin 1 (VPS OUT)	R16 (VPS Y LEVEL)	• Modulated signal	<ol style="list-style-type: none"> 1. Receive an 87.5% modulated signal. Adjust R16 to obtain a maximum Y level (including sync) of 2.0 Vp-p from pin 1 (VPS OUT) of CN4.
6	Colour Level	CN2, pin 3 (VIDEO OUT)	R42 (COLOUR LEVEL)	• Colour Bar	<ol style="list-style-type: none"> 1. Receive a colour bar signal. With Y level taken as 100%, adjust R42 for a magenta level of 48% at pin 3 (VIDEO OUT) of CN2. <div style="text-align: center;">  <p>B: magenta E/EG A:B = 1:0.44 EK A:B = 1:0.48</p> </div> <p style="text-align: center;">Fig. 2-9-3</p>
7	Audio Level (EK only)	CN2, pin 5 (AUDIO OUT)	R32 (AUDIO LEVEL)	• Colour Bar • 1 kHz audio RF signal	<ol style="list-style-type: none"> 1. Receive a colour bar signal and 1 kHz (± 50 kHz dev.) audio RF signal. 2. Adjust R32 for -14 dBs (4.5 Vp-p) at pin 5 (AUDIO OUT) of CN2.

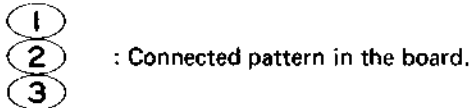
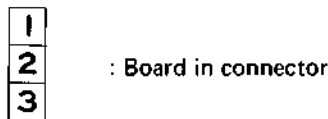
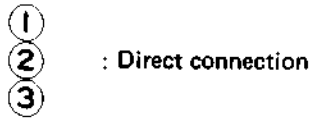
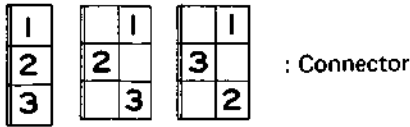
SECTION 3 CHARTS AND DIAGRAMS

3.1 CIRCUIT BOARD LOCATIONS AND GENERAL INFORMATION

No.	NAMES
01	POWER TRANSFORMER
02	REGULATOR
03	VIDEO/MECHA/CON/SERVO
04	-
05	-
06	TERMINAL
07	TUNER/IF
09	AUDIO (FM/NOR)
12	A/CTL HEAD
14	DEMODULATOR (E/EG)
18	JUNCTION
19	VPS (E/EG)
19	POWER TRANSISTOR
21	FRONT
25	HEADPHONE
30	-
41	UPPER DRUM
42	DRUM HEAD
50	-
51	DECK TERMINAL
52	RELAY
53	REC SAFETY
54	END SENSOR
55	-
56	LED
57	-
58	DRUM MOTOR
60	-



3.1.1 Connections

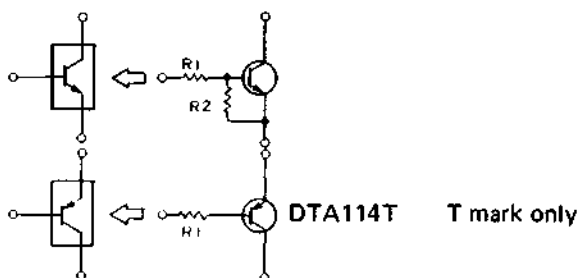


3.1.2 Indications

COUNT UP : Active only at high.

COUNT DOWN : Active only at low.

3.1.3 Digital transistor



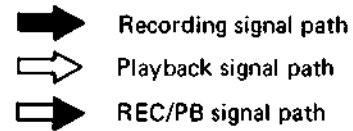
Note:

The digital transistor includes built in resistors. It features small size and high reliability. Both PNP and NPN types are available.

Uses:

Inverter, Interface, driver circuits.

3.1.4 Signal flow in the schematic



3.1.5 Schematic diagram values

Unless otherwise specified.

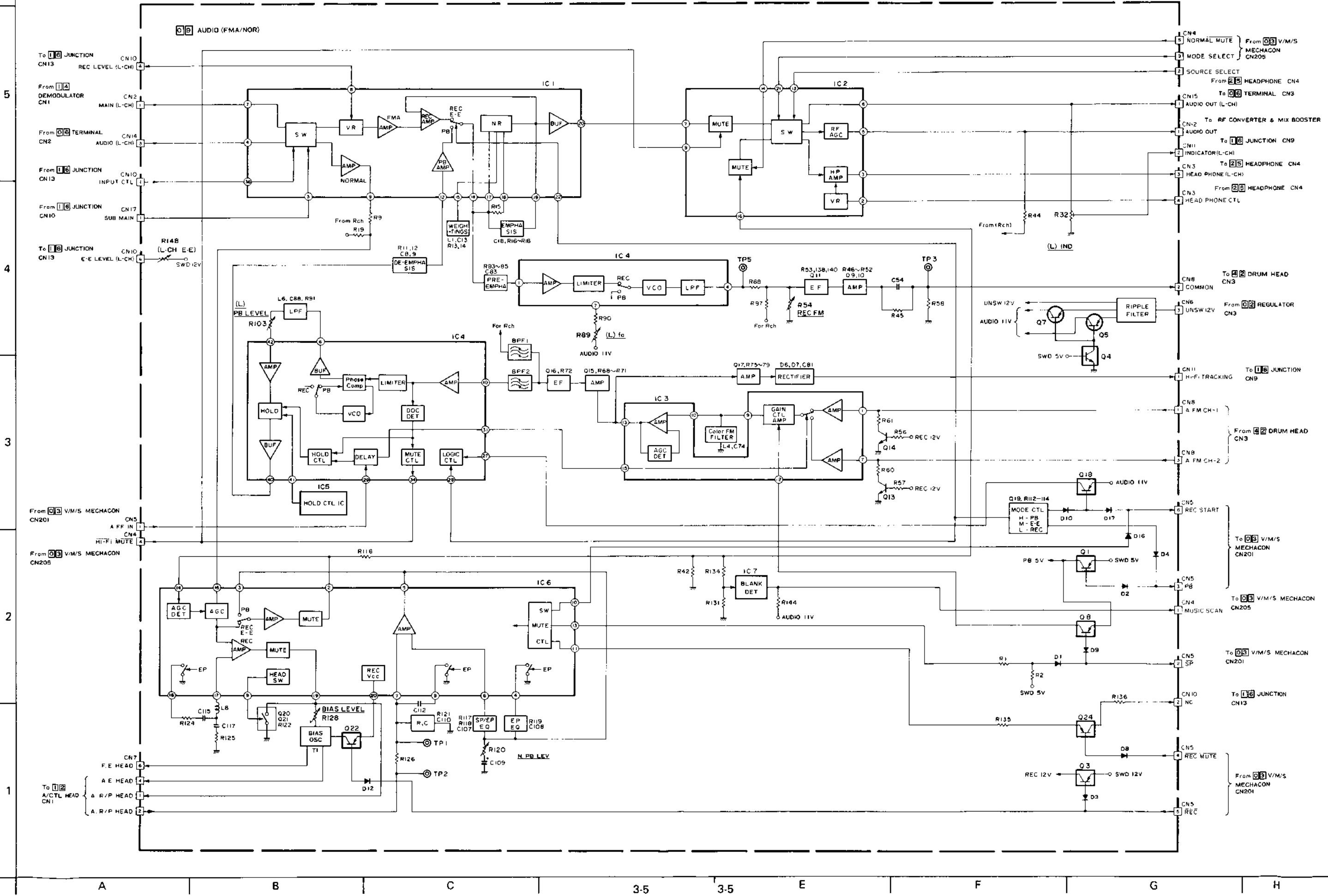
1. All resistance values are in ohms, 1/6 W, 1/8 W (refer to parts list).
2. All capacitance values are in μF , (P; PF).
3. All inductance values are in μH , (m; mH).
4. All diodes are 1SS133 or MA165, (refer to parts list).
5. Voltages are DC-measured with a digital voltmeter during recording (SP mode) and playback (SP mode) with alignment tape. Where voltages differ between recording and playback, the voltage during playback is shown in parentheses.
6. Waveforms (VIDEO System) are measured with a color bar during recording (SP mode) and playback (SP mode) with alignment tape.
7. Waveforms (AUDIO System) are measured with 1 kHz (-8 dBs) during recording and playback with alignment tape (1 kHz).
8. Shaded (▨) Parts are critical for safety. Replace only with specified parts numbers.

3.2 KEY TO ABBREVIATIONS

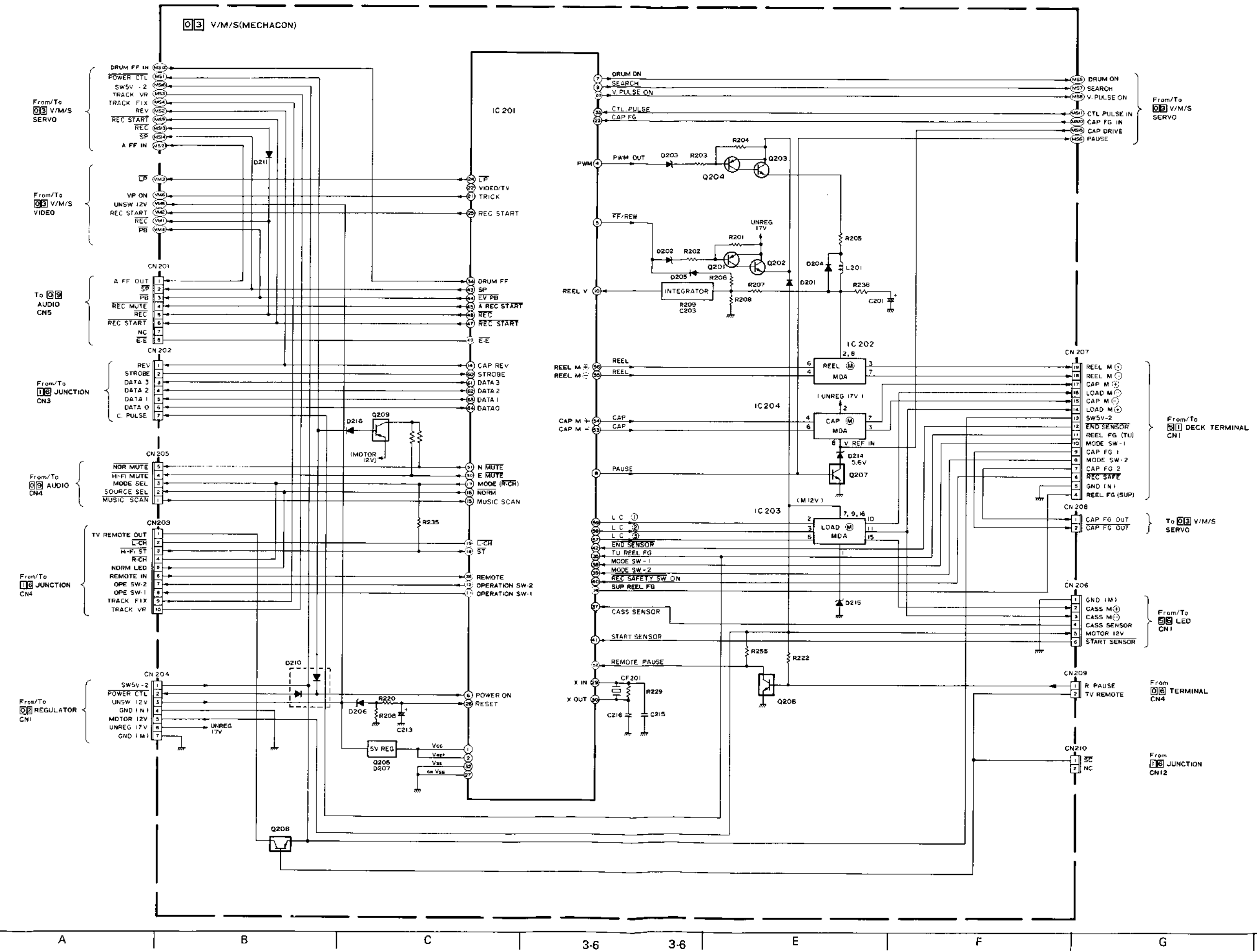
A	A/CTL	: Audio/Control	DL	: Delay Line
	ADC	: Analog to Digital Converter	DOC	: Dropout Compensator
	ADD	: Adder	DPC	: Drum Phase Control
	ADJ	: Adjustment	DYAC	: Dynamic Aperture Control
	A DUB	: Audio Dubbing		
	AE	: Audio Erase	E	E
	AEF	: Automatic Editing Function		EOP
	AFC	: Automatic Frequency Control		E-E
	AFT	: Automatic Fine Tuning		EF
	AH	: Audio Head		EMP
	AL	: After Loading		ENC
	ALC	: Automatic Ligh Compensation Automatic Level Control		EN
	ALM	: Alarm		ENV
	AM	: Amplitude Modulation		EP
	AMP	: Amplifier		EQ
	ANT	: Antenna		ES
	APC	: Automatic Pedestal Control Automatic Phase Control		ESNS
	APL	: Average Picture Level		EXP
	ASS'Y	: Assembly		EXT
	ATT	: Attenuator		
	AUD	: Audio	F	F
	AUTO	: Automatic		F ADV
	AUX	: Auxiliary		FE
				FET
				FF
B	B	: Base		FM
	BAL	: Balance		FMA
	BATT	: Battery		FR
	BLK	: Black, Blanking		F REQ
	BLU	: Blue		F-V CONV
	BPF	: Bandpass Filter		FWD
	BRK	: Brake		FWDS
	BRN	: Brown		
	BUFF	: Buffer	G	G
	BW or B/W	: Black and White		GEN
				GND
				GRN
				GRY
C	C	: Capacitance, Collector, Color, Ceramic		
	CAP	: Capstan, Capacitor	H	H
	CARR	: Carrier		HBF
	CASS	: Cassette		HD
	CCD	: Charge Coupled Device		HG
	CCT	: Circuit		HPF
	CD	: Count Down		HRC
	CF	: Ceramic Filter, Color Frame		
	CE	: Chip Enable	I	ID
	CH	: Channel		IF
	CHROMA	: Chrominance		IFR
	CLK	: Clock		IFT
	CLR	: Clear		IND
	CMOS	: Complementary Metal Oxide Semicon- ductor		INH
	CMD	: Command		INS
	CNT	: Count, Counter		INT
	CONV	: Converter		INV
	COL	: Color		I/O
	COM	: Common		IR
	COMB	: Comb Filter		
	COMP	: Comparator, composite, compensation	L	L
	CONN	: Connector		LCD
	CP	: Circuit Protector, Clamp Pulse		LED
	CPC	: Capstan Phase Control		LIN
	CTL	: Control		LIM
				LOAD
				LP
				LPF
				LSB
D	D	: Drum, Digital, Diode, Drain		
	DAC	: Digital to Analog Converter	M	M
	DD	: Direct Drive		MAX
	DEC	: Decoder		MDA
	DEMOD	: Demodulator		
	DEMUX	: Demultiplexer		
	DET	: Detector		
	DEV	: Deviation		
	DIF	: Differential		
	DISCR	: Discriminator		

MECHACON	: Mechanism Control	SEP	: Separator
MIC	: Microphone	SF	: Source Follower
MIN	: Minimum	SFF	: Short Fast Forward
MIX	: Mixer, Mixing	SIF	: Sound Intermediate Frequency
MMV	: Monostable Multivibrator	SN	: Signal to Noise Ratio
MNOS	: Metal Nitride Oxide Semiconductor	SP	: Standard Play
MOD	: Modulation, Modulator	SREW	: Short Rewind
MODEM	: Modulator-Demodulator	S/S	: Slow/Still
MON	: Monitor	SSNS	: Start Sensor
MOS	: Metal Oxide Semiconductor	STD	: Strobe Data, Standard
MPX	: Multiplexer, Multiplex	SUP	: Supply
MS	: Mode Select	SW	: Switch
MUT	: Muting	SWD	: Switched
<hr/>		SYNC	: Synchronization
N		T	
NAND	: Not-And	TP	: Test Point
NC	: Not Connected, Normally Closed	TPZD	: Trapezoid
NFB	: Negative Feedback	TR	: Transistor, Trimmer
NLN	: Non-Linear	Trans	: Transformer
NO	: Normally Open	TU	: Take-Up
NOR	: Normal, Not-Or	TEN	: Tension
NR	: Noise Reduction	TF	: Thermal Fuse
<hr/>		TK	: Tracking
O		TNR	: Tuner
OPAMP	: Operational Amplifier	TIM	: Timing
OP	: Operation	<hr/>	
ORN	: Orange	U	
OSC	: Oscillator	UL	: Unloading
<hr/>		UNREG	: Unregulated
P		UNSW	: Unswitched
PB	: Playback	<hr/>	
PC	: Photocoupler, Pulse Counter	V	
PCM	: Pulse Code Modulation	V	: Volt, Vertical
PGM	: Program	VCO	: Voltage Controlled Oscillator
PG	: Pulse Generator	VD	: Vertical Drive
PI	: Photo Interrupter	VIF	: Video Intermediate Frequency
PIF	: Picture Intermediate Frequency	VS	: Video and Sync
PLA	: Programmable Logic Array	VXO	: Variable Crystal Oscillator
PLL	: Phase Locked Loop	VLT	: Violet
p-p	: Peak-to-Peak	V/T	: Video/Television
POS	: Position	V/U	: VHF/UHF
PREAMP	: Preamplifier	VSCH	: Variable Search
P/S	: Pause/Still	<hr/>	
PSC	: Pulse Swallowing Control	W	
PU	: Pickup	WHT	: White
PUT	: Programmable Unijunction Transistor	W & D	: White and Dark
PWM	: Pulse Width Modulation	WARN	: Warning
PWR	: Power	<hr/>	
<hr/>		X	
Q		XTAL	: Crystal
Q	: Quality Factor	<hr/>	
<hr/>		Y	
R		Y	: Luminance
R	: Red, Right	YEL	: Yellow
RA	: Resistor Array	<hr/>	
RAM	: Random Access Memory		
REC	: Recording		
REG	: Regulated, Regulator		
REF	: Reference		
REM	: Remote		
REMOCON	: Remote Control (Unit)		
REV	: Reverse		
REVS	: Reverse Search		
REW	: Rewind		
RF	: Radio Frequency		
ROM	: Read Only Memory		
RST	: Reset		
R/P	: Record/Playback		
RPT	: Repeat		
RT	: Rotary Transformer		
RUN	: Running		
RY	: Relay		
<hr/>			
S			
SAP	: Second Audio Program		
SAW	: Sawtooth, Surface Acoustic Wave		
SC	: Subcarrier, Simulcast		
SCH	: Search		
SEL	: Select, Selector		
SENS	: Sensor		

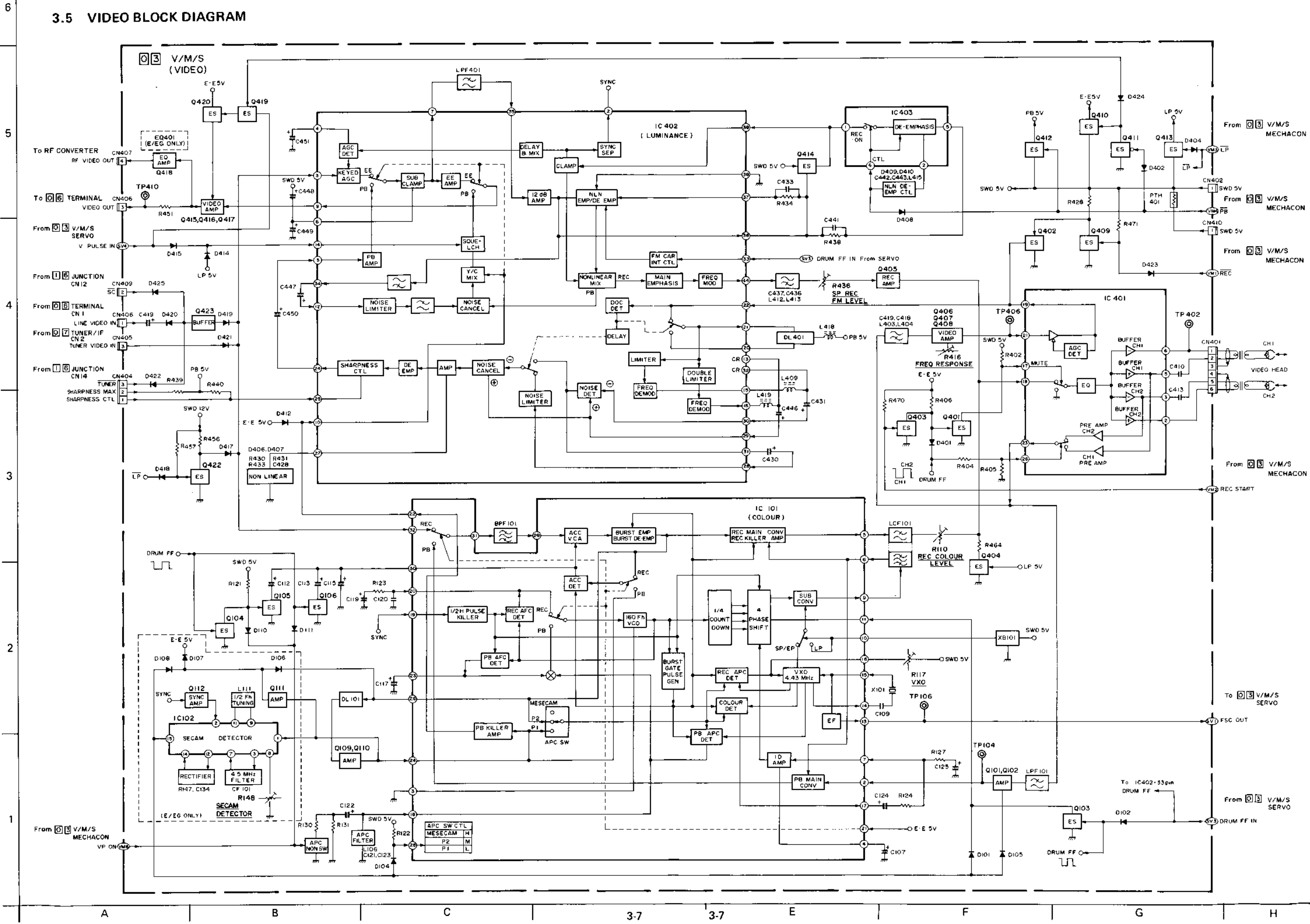
3.3 FM/NORMAL AUDIO BLOCK DIAGRAM



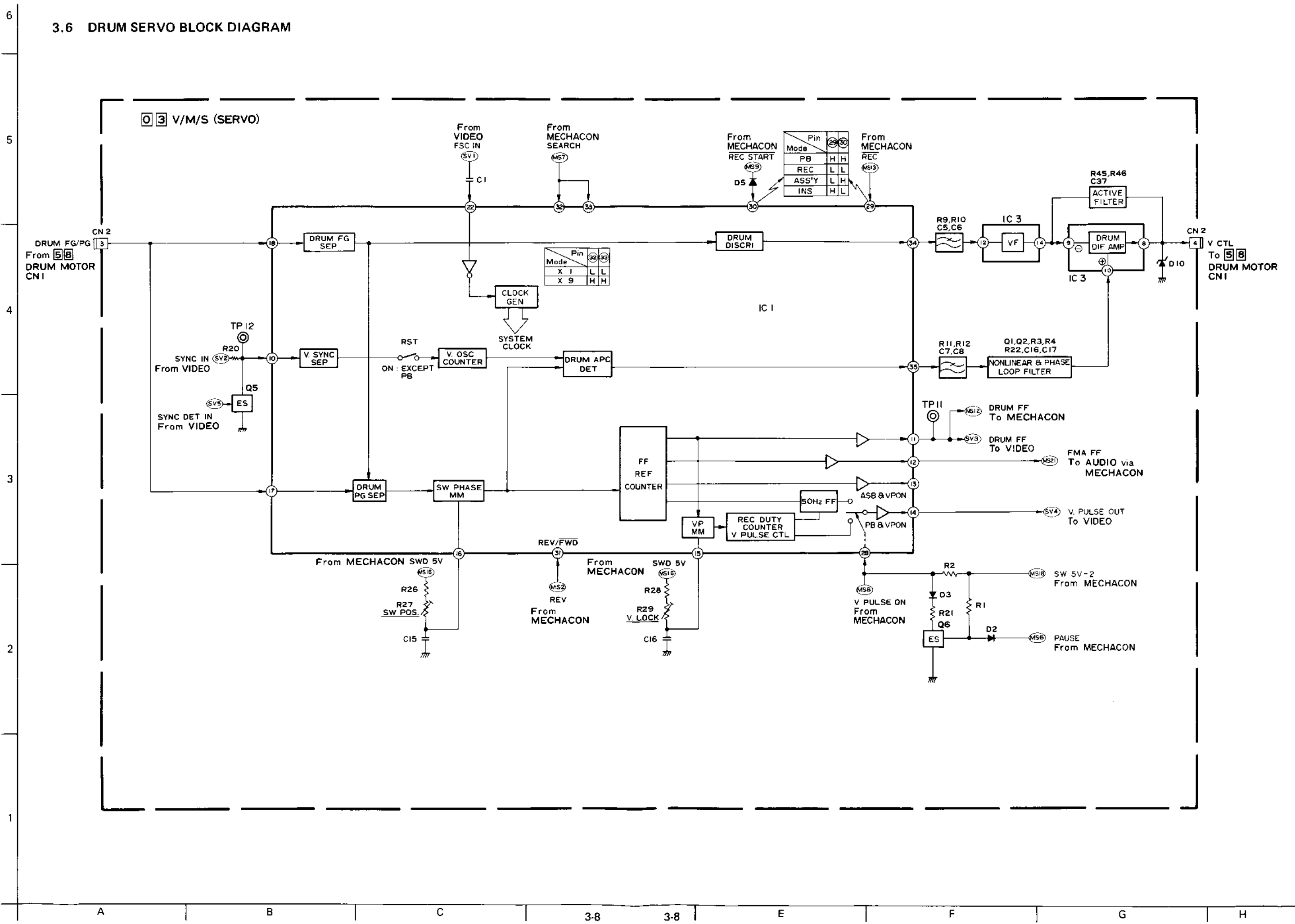
3.4 MECHACON BLOCK DIAGRAM



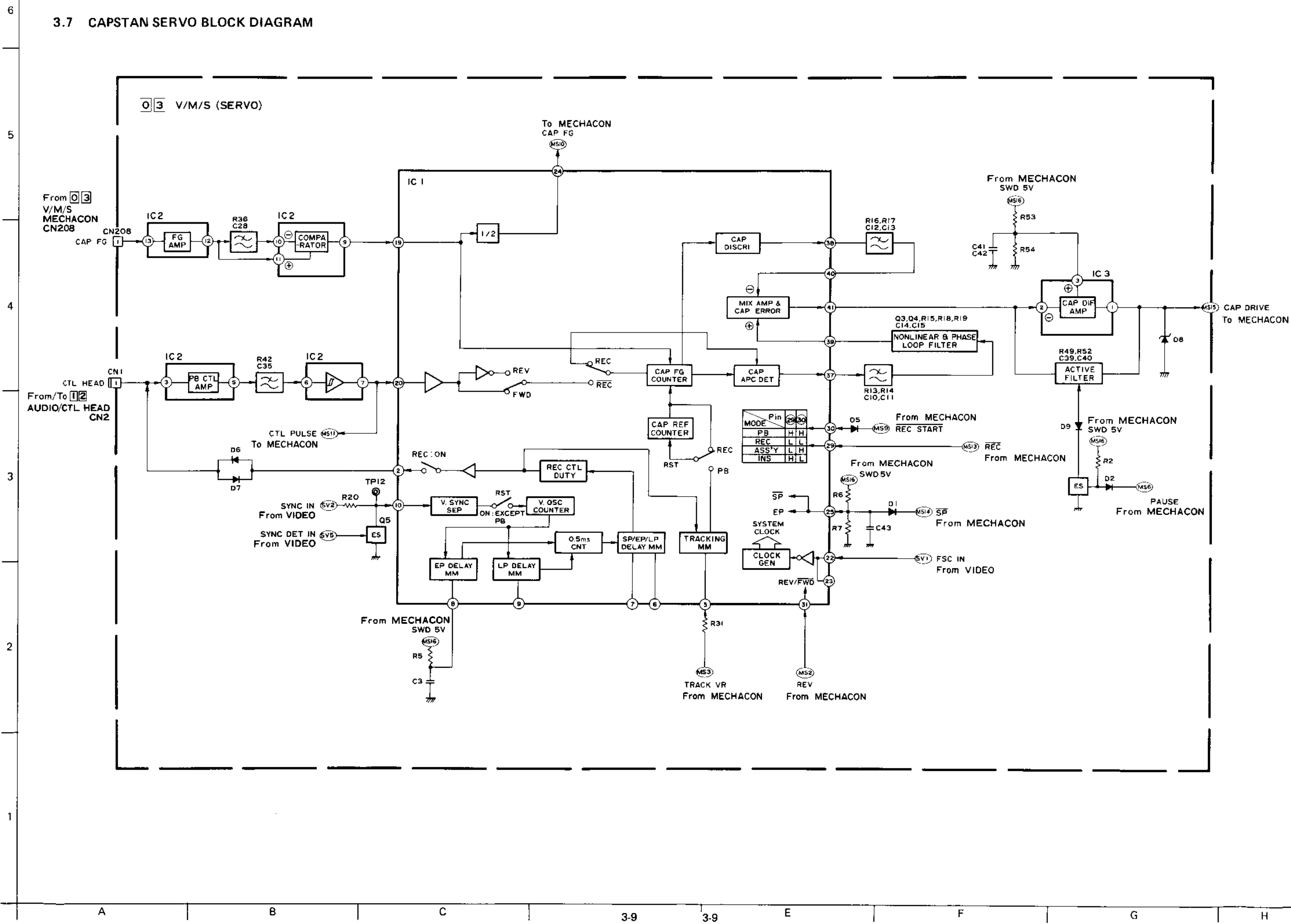
3.5 VIDEO BLOCK DIAGRAM



3.6 DRUM SERVO BLOCK DIAGRAM

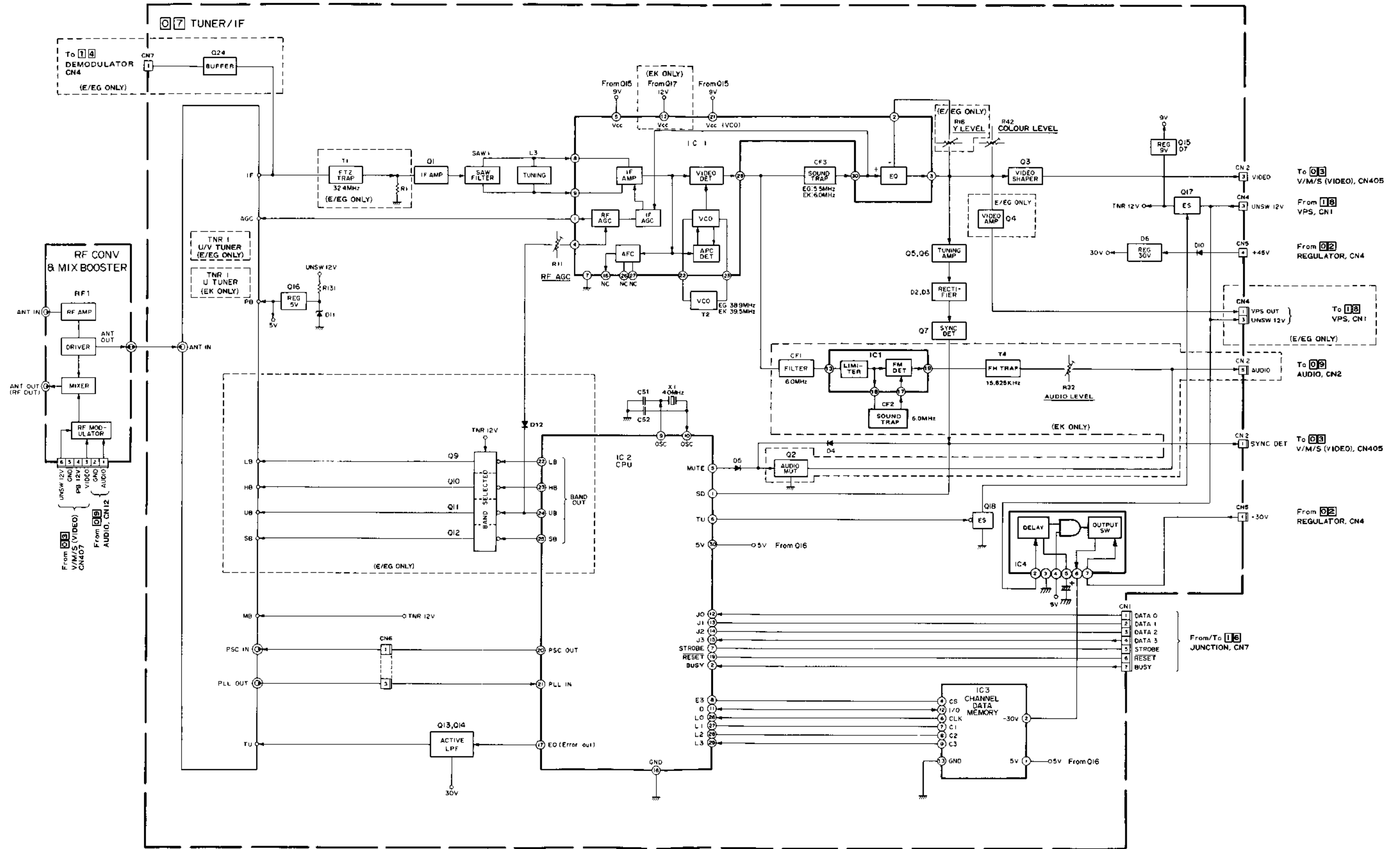


3.7 CAPSTAN SERVO BLOCK DIAGRAM



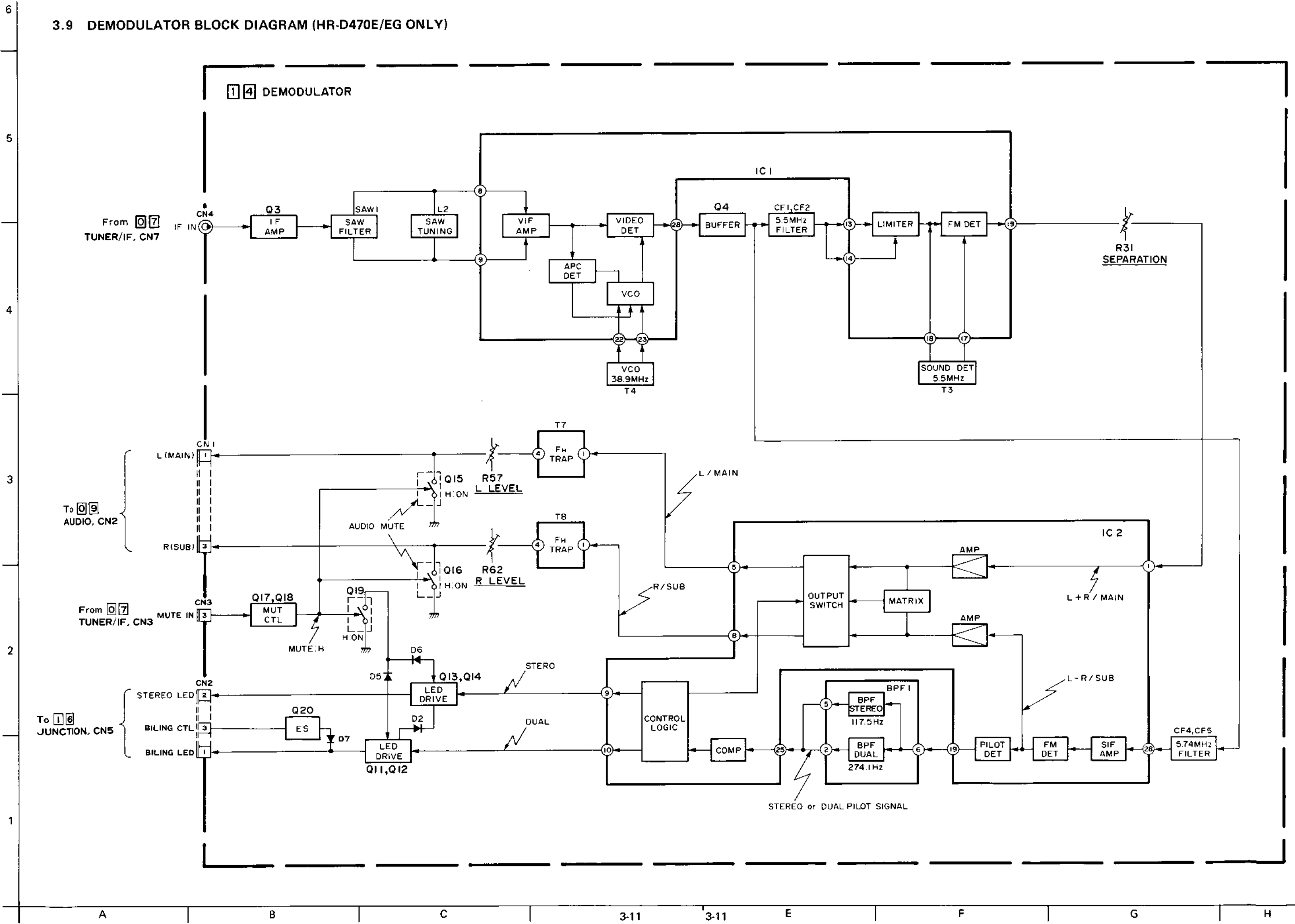
3.8 TUNER/IF BLOCK DIAGRAM

6
5
4
3
2
1

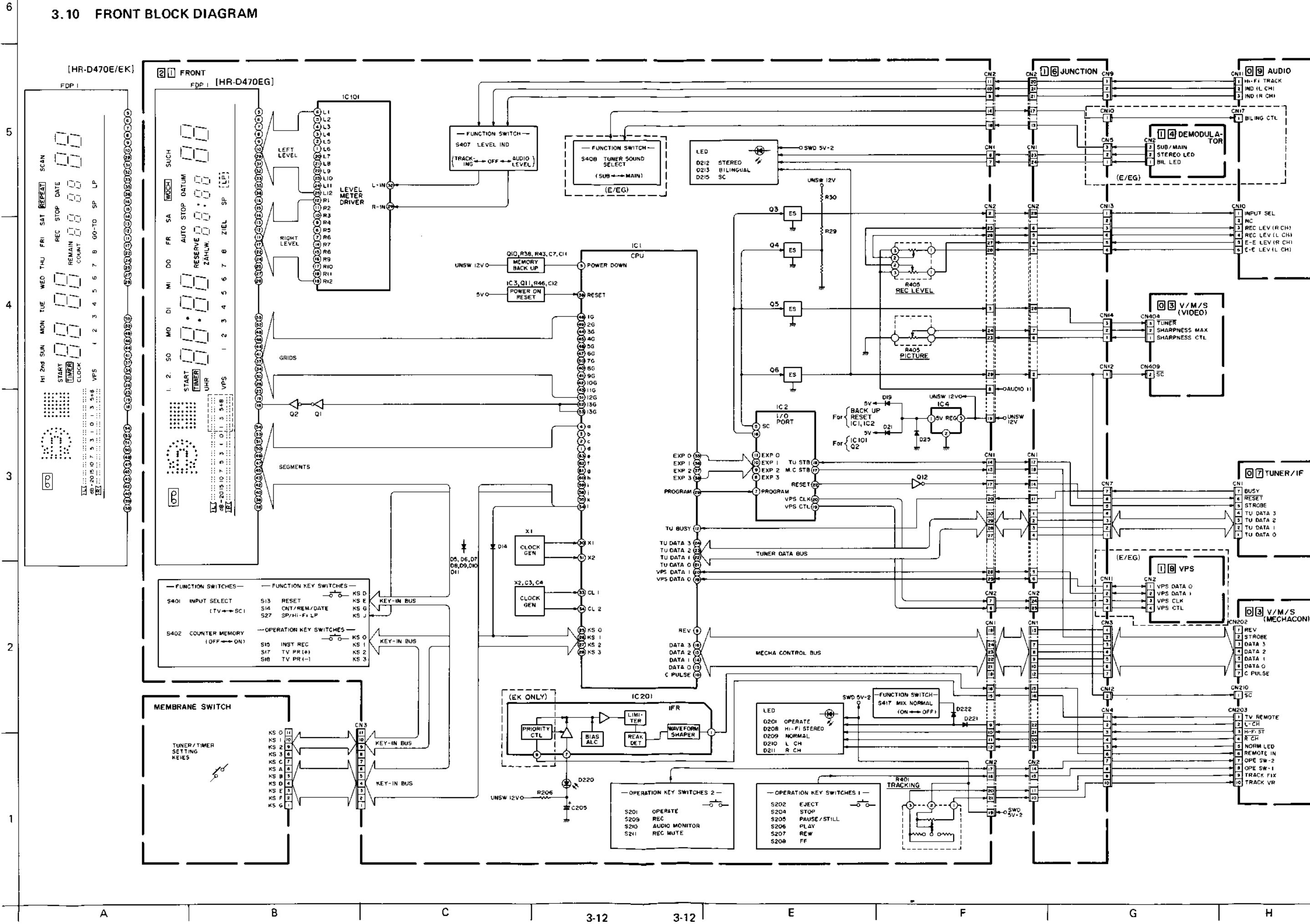


A B C 3-10 3-10 E F G H

3.9 DEMODULATOR BLOCK DIAGRAM (HR-D470E/EG ONLY)

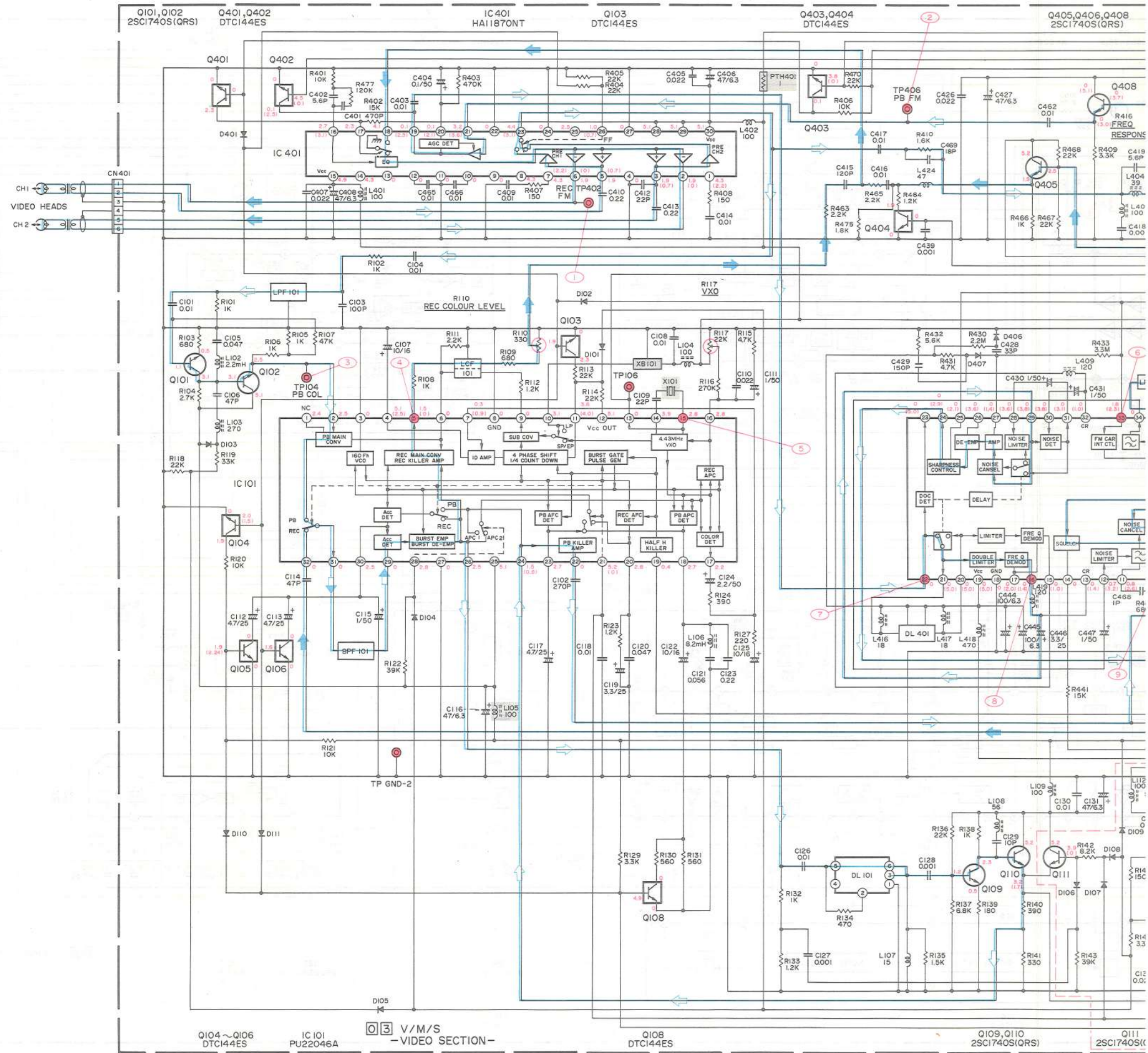
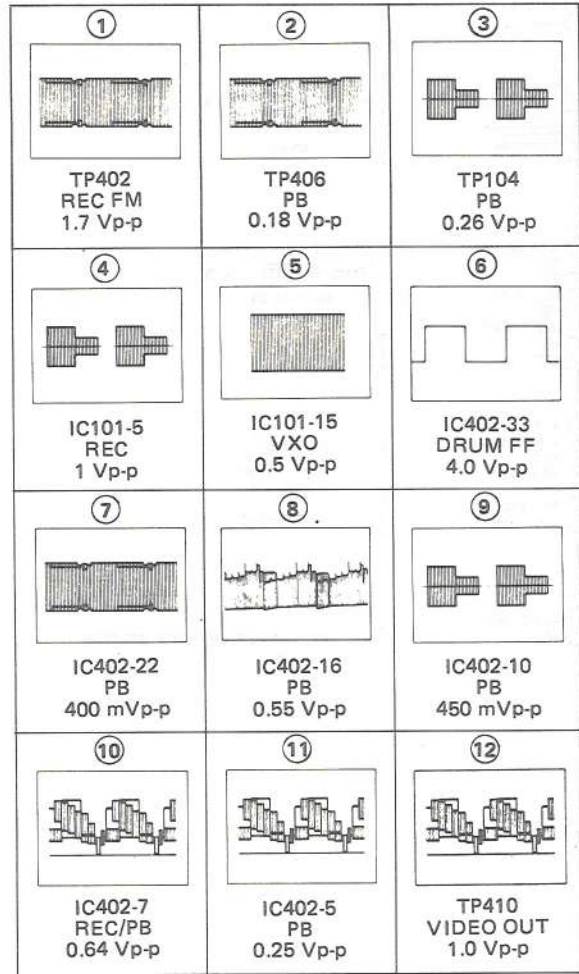


3.10 FRONT BLOCK DIAGRAM



3.11 VIDEO (V/M/S) SCHEMATIC DIAGRAM

- Waveforms of VIDEO CIRCUIT -



A

B

C

3-13

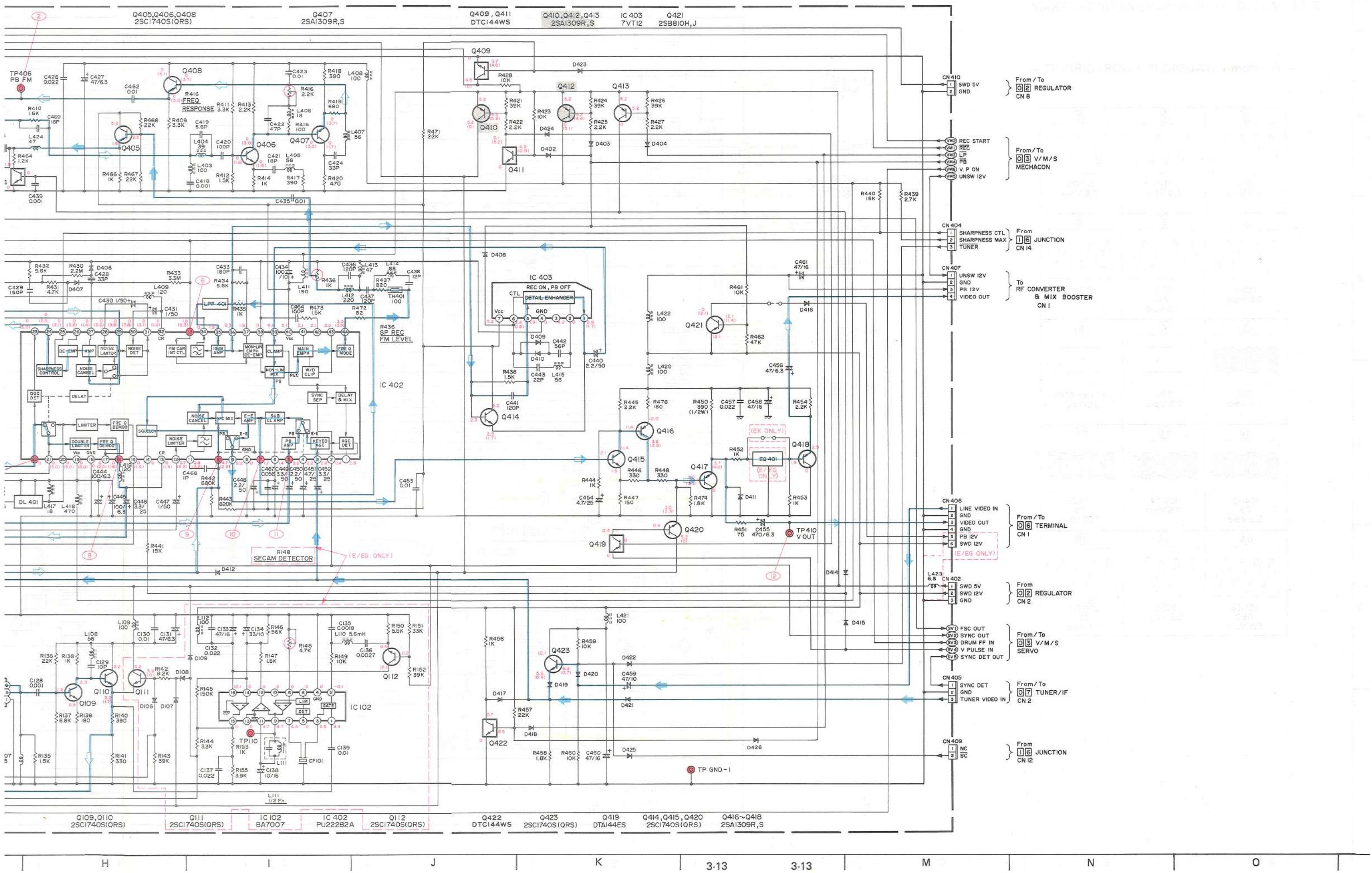
3-13

E

F

G

H



From/To
REGULATOR
CN 8

From/To
V/M/S
MECHACON

From
JUNCTION
CN 14

To
RF CONVERTER
& MIX BOOSTER
CN 1

From/To
TERMINAL
CN 1

From
REGULATOR
CN 2

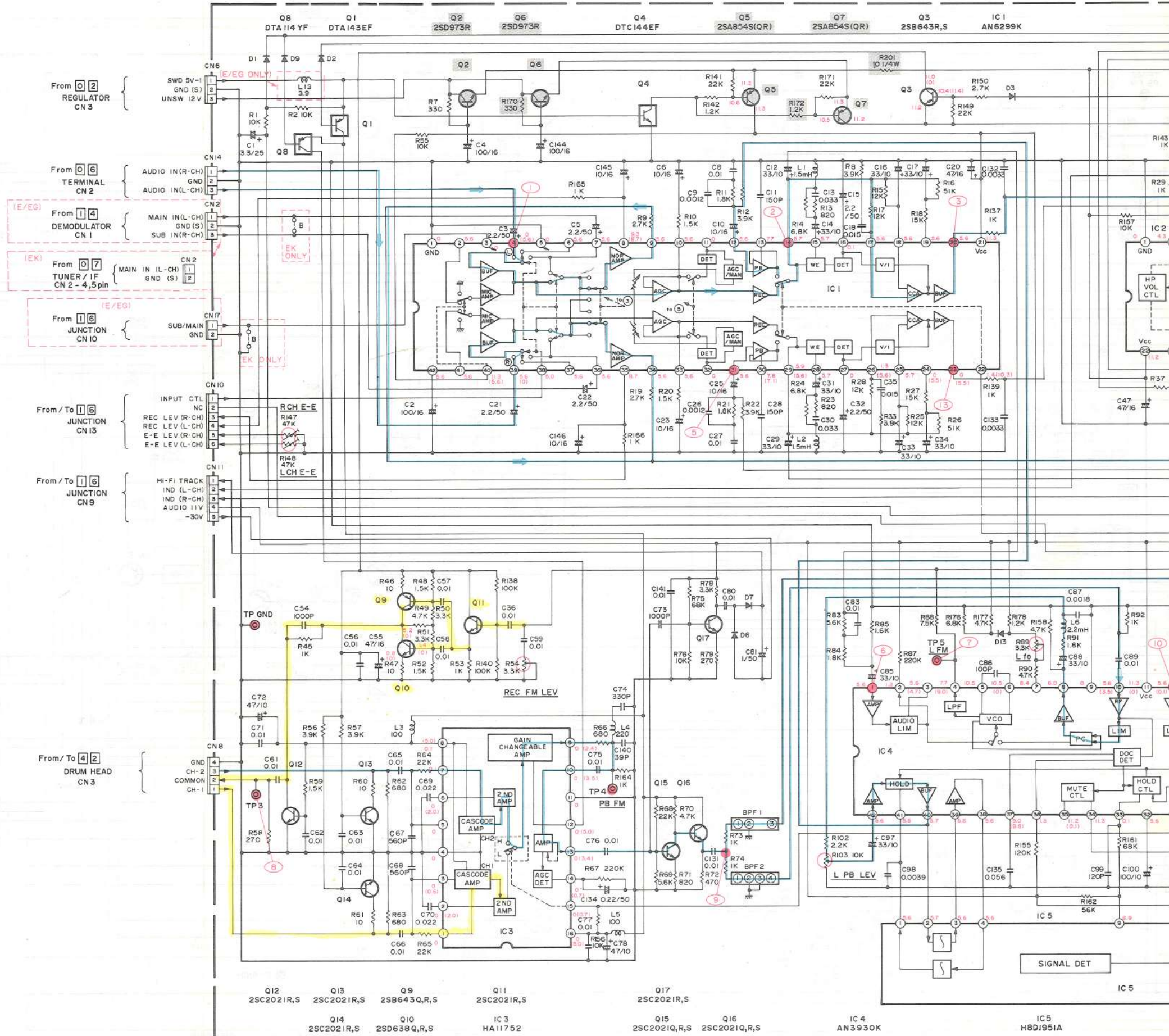
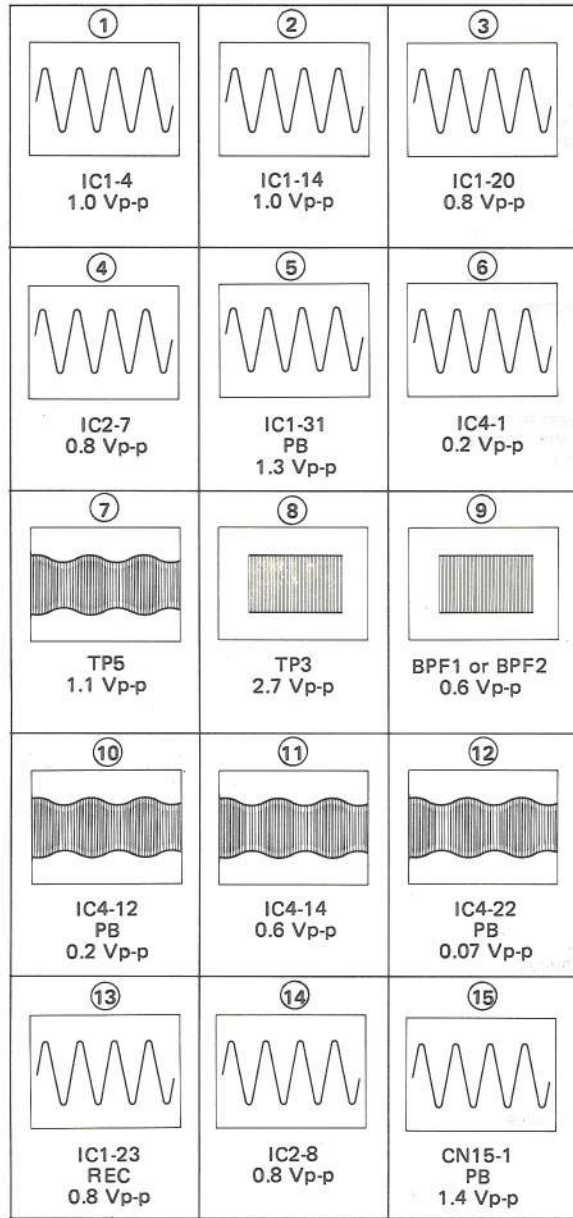
From/To
V/M/S
SERVO

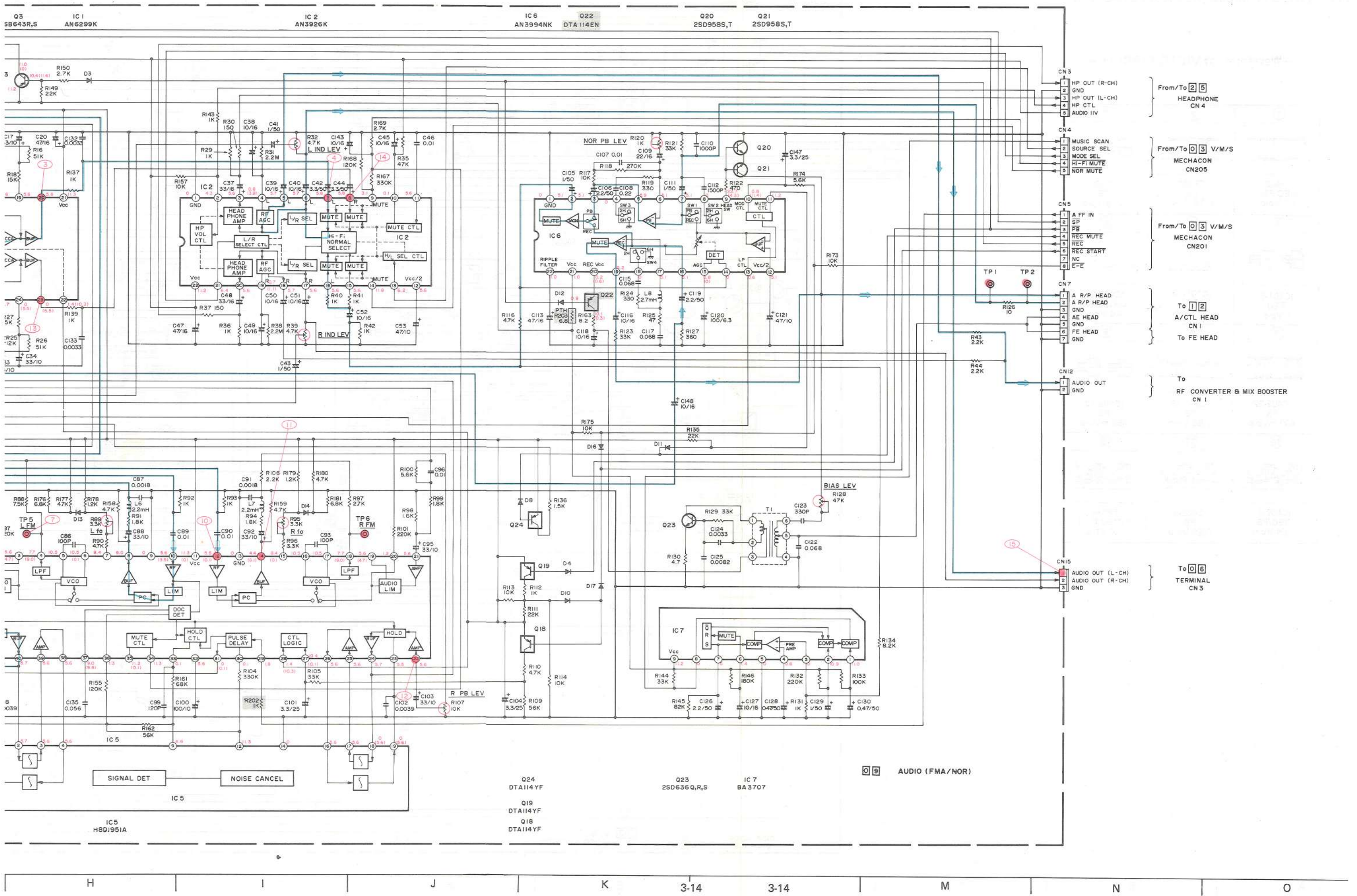
From/To
TUNER/IF
CN 2

From
JUNCTION
CN 12

3.12 AUDIO (FM/NOR) SCHEMATIC DIAGRAM

— Waveforms of AUDIO (FM/NOR) CIRCUIT —





From/To 2 5
HEADPHONE
CN 4

From/To 0 3 V/M/S
MECHACON
CN205

From/To 0 3 V/M/S
MECHACON
CN201

To 1 2
A/CTL HEAD
CN 1
To FE HEAD

To
RF CONVERTER & MIX BOOSTER
CN 1

To 0 6
TERMINAL
CN 3

0 9 AUDIO (FMA/NOR)

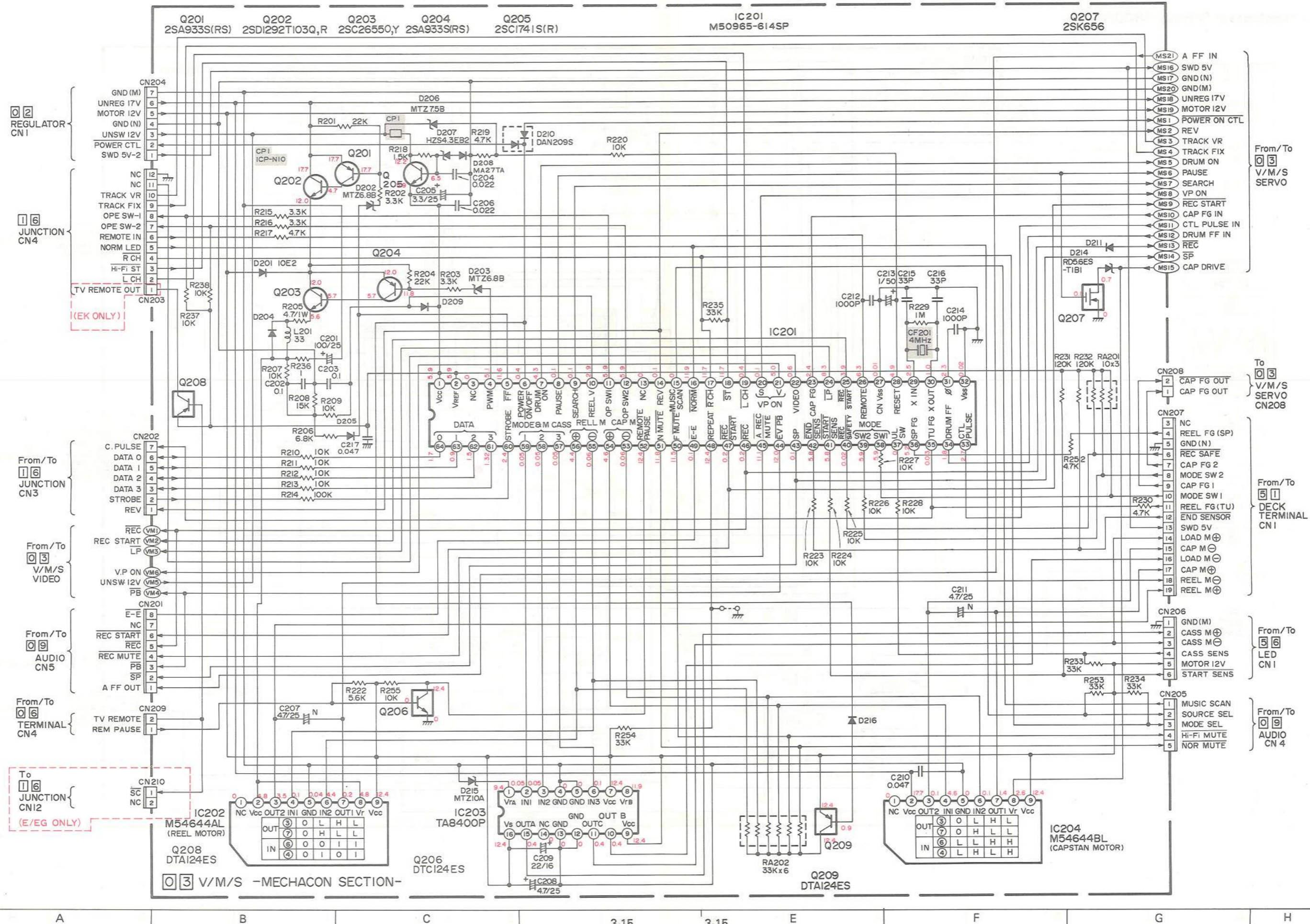
Q24 DTA114YF
Q19 DTA114YF
Q18 DTA114YF
Q23 2SD636Q,R,S
IC 7 BA3707

IC 5 H8D1951A

H I J K 3-14 3-14 M N O

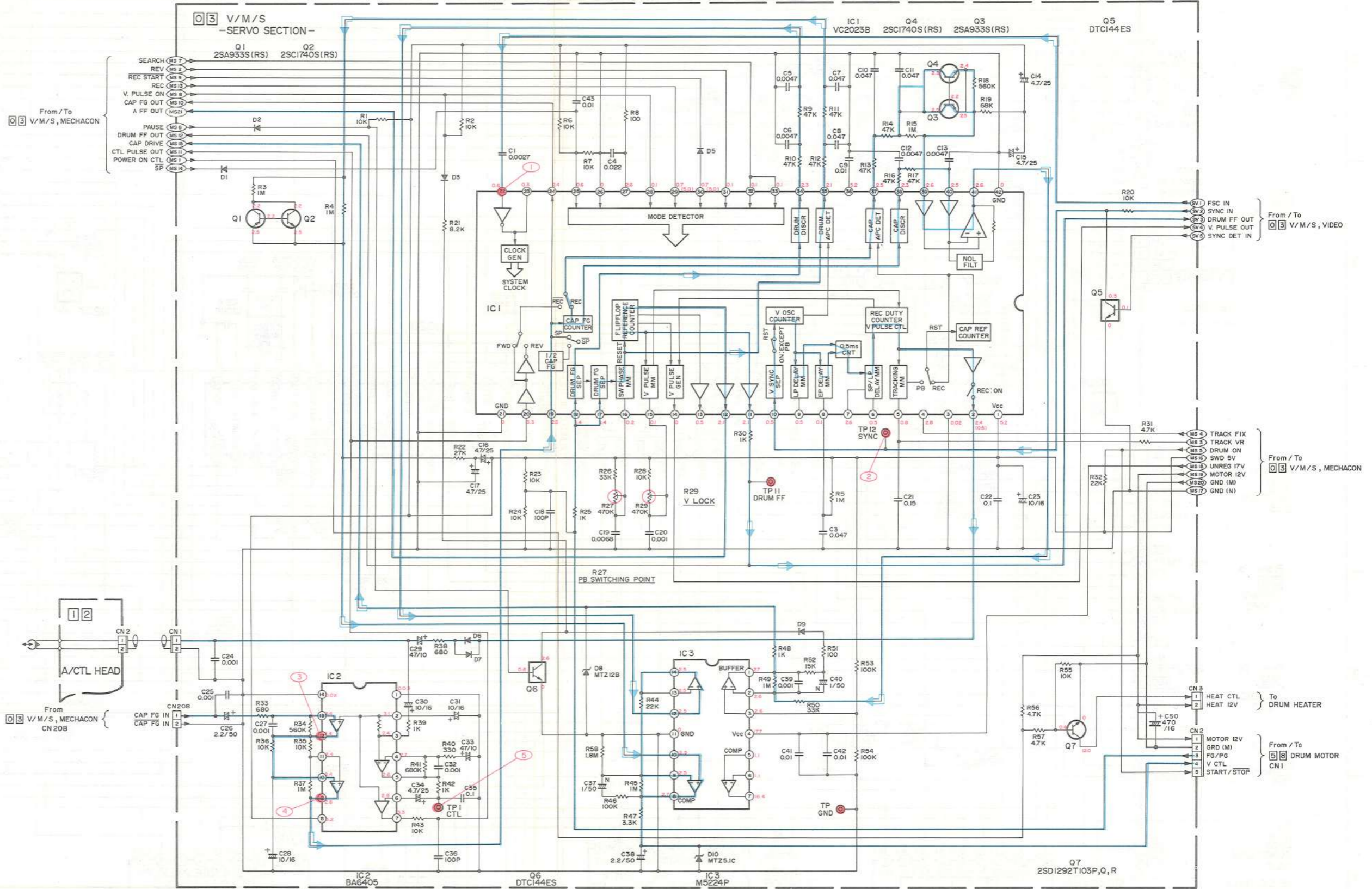
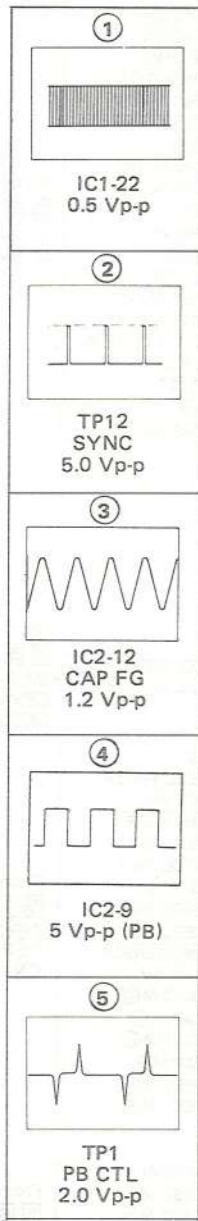
3.13 MECHACON (V/M/S) SCHEMATIC DIAGRAM

NOTE: Voltages are DC-measured with a digital voltmeter during stop mode.

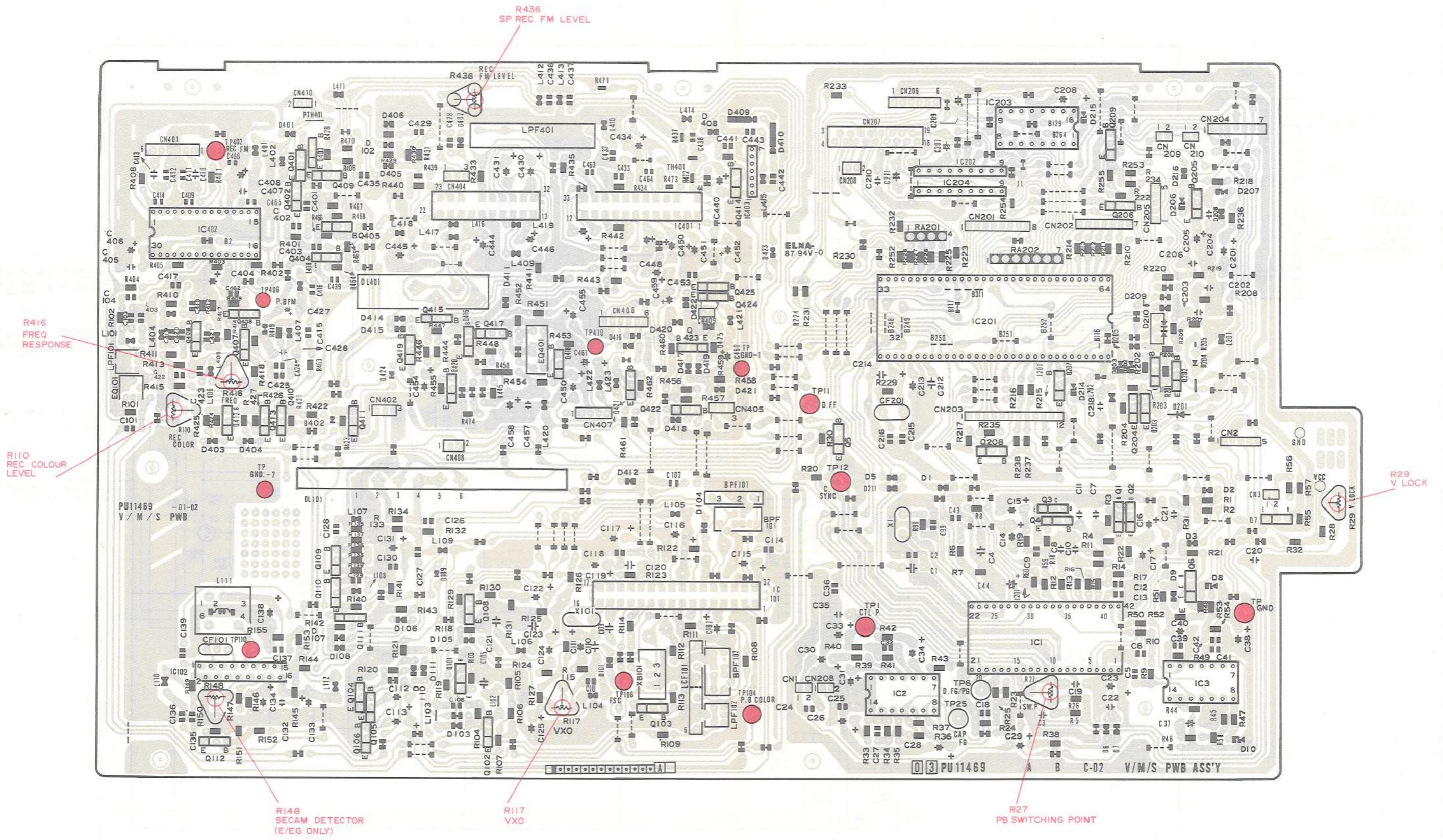


3.14 SERVO (V/M/S) SCHEMATIC DIAGRAM

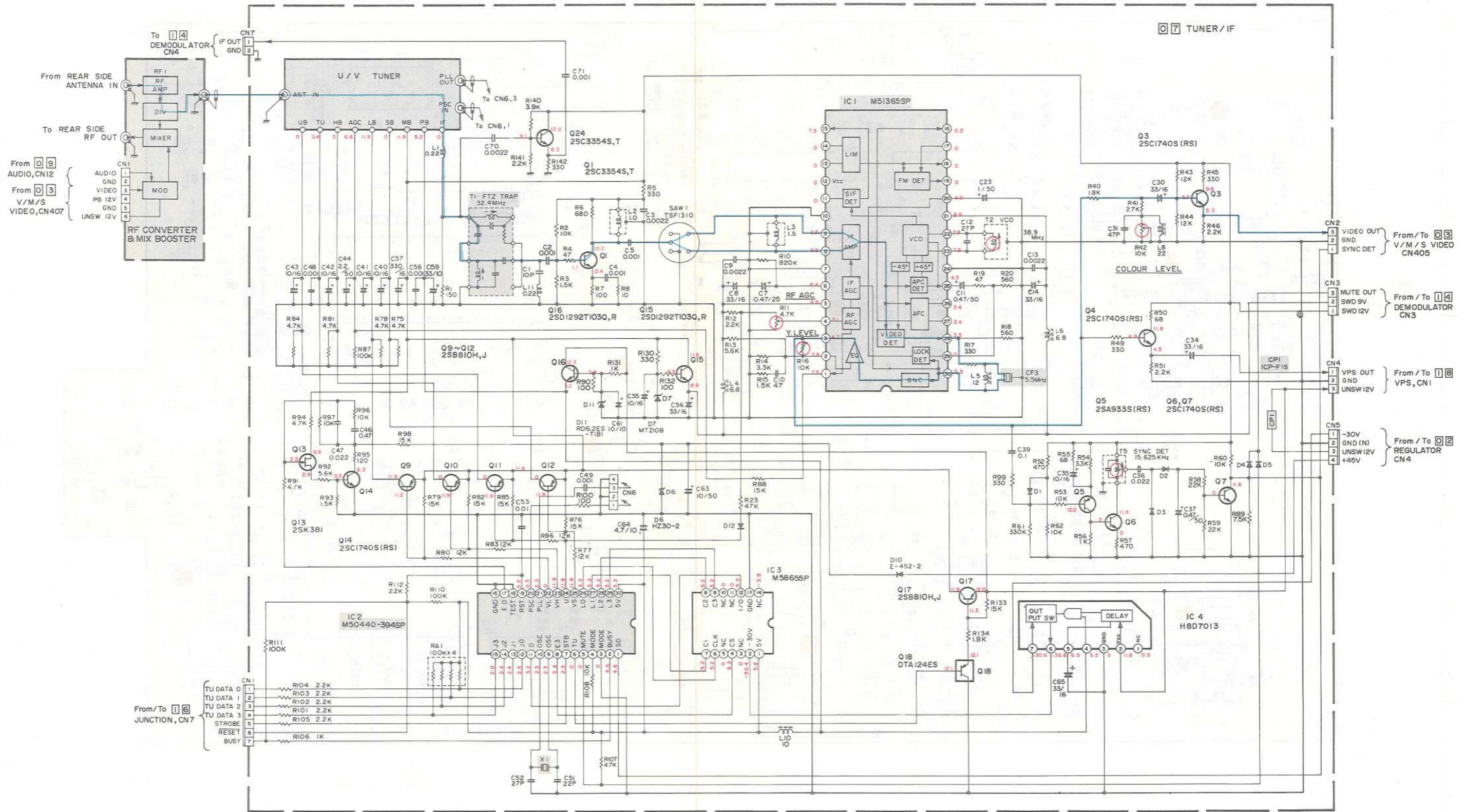
— Waveforms of SERVO CIRCUIT —



3.15 VIDEO/MECHACON/SERVO CIRCUIT BOARD

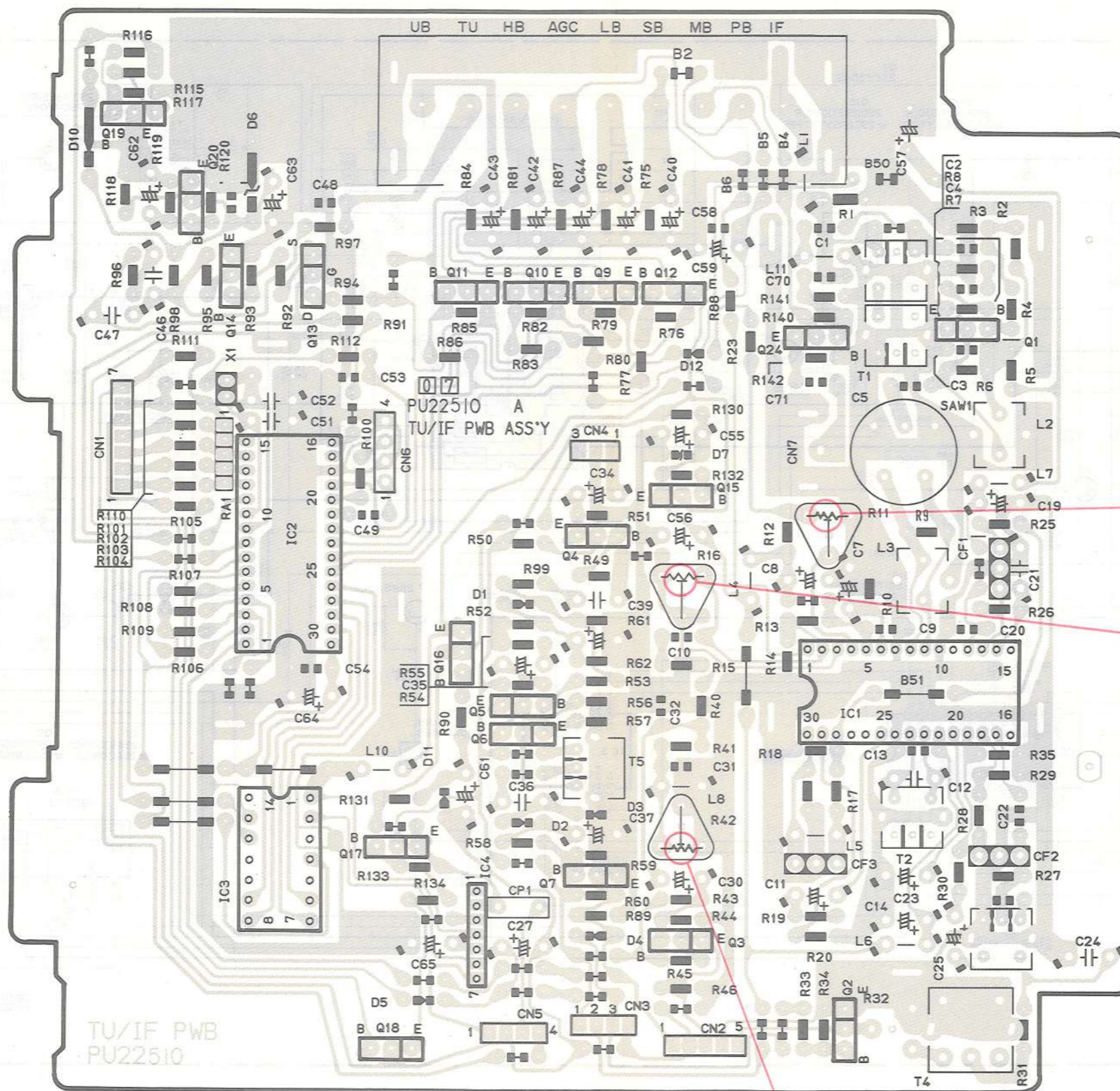


3.16 TUNER/IF SCHEMATIC DIAGRAM (HR-D470E/EG)



NOTE: Voltages are DC-measured with a digital voltmeter during stop mode.

3.17 TUNER/IF CIRCUIT BOARD (HR-D470E/EG)



R11
RF AGC

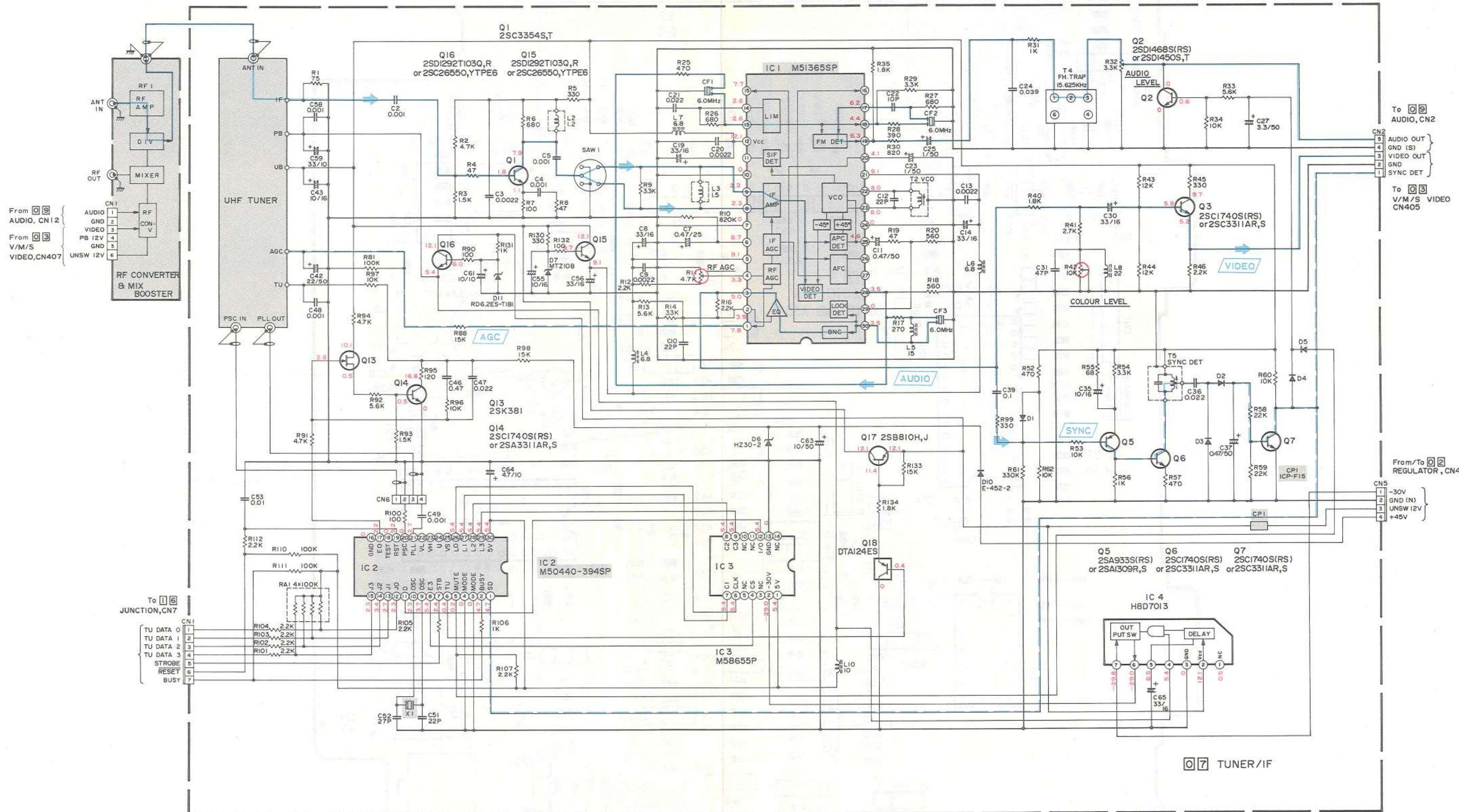
R16
Y LEVEL

R42
COLOUR LEVEL

6
5
4
3
2
1

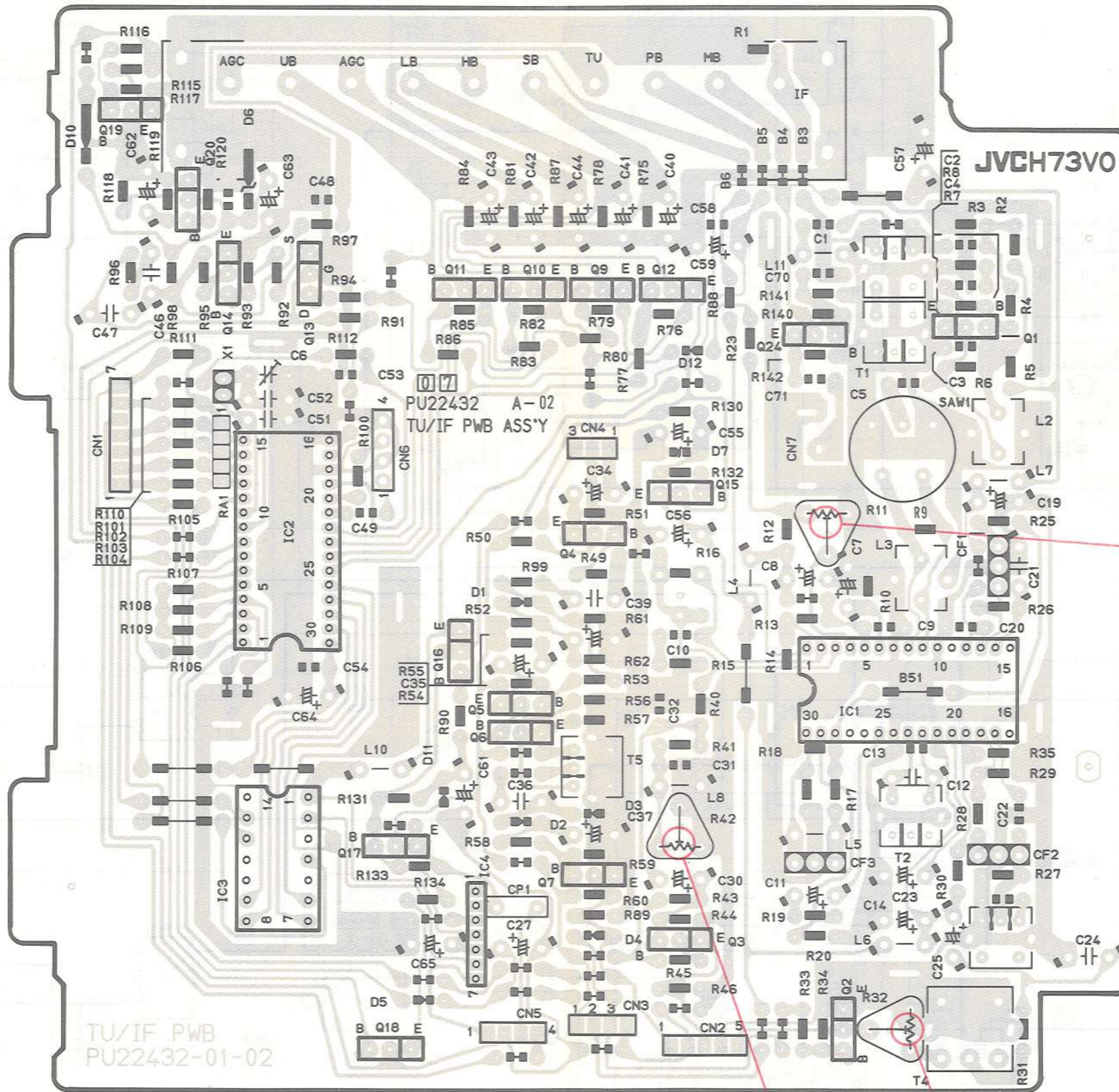
A B C 3-19 3-19 E F G H

3.18 TUNER/IF SCHEMATIC DIAGRAM (HR-D470EK)



NOTE: Voltages are DC-measured with a digital voltmeter during stop mode.

3.19 TUNER/IF CIRCUIT BOARD (HR-D470EK)



R11
RF AGC

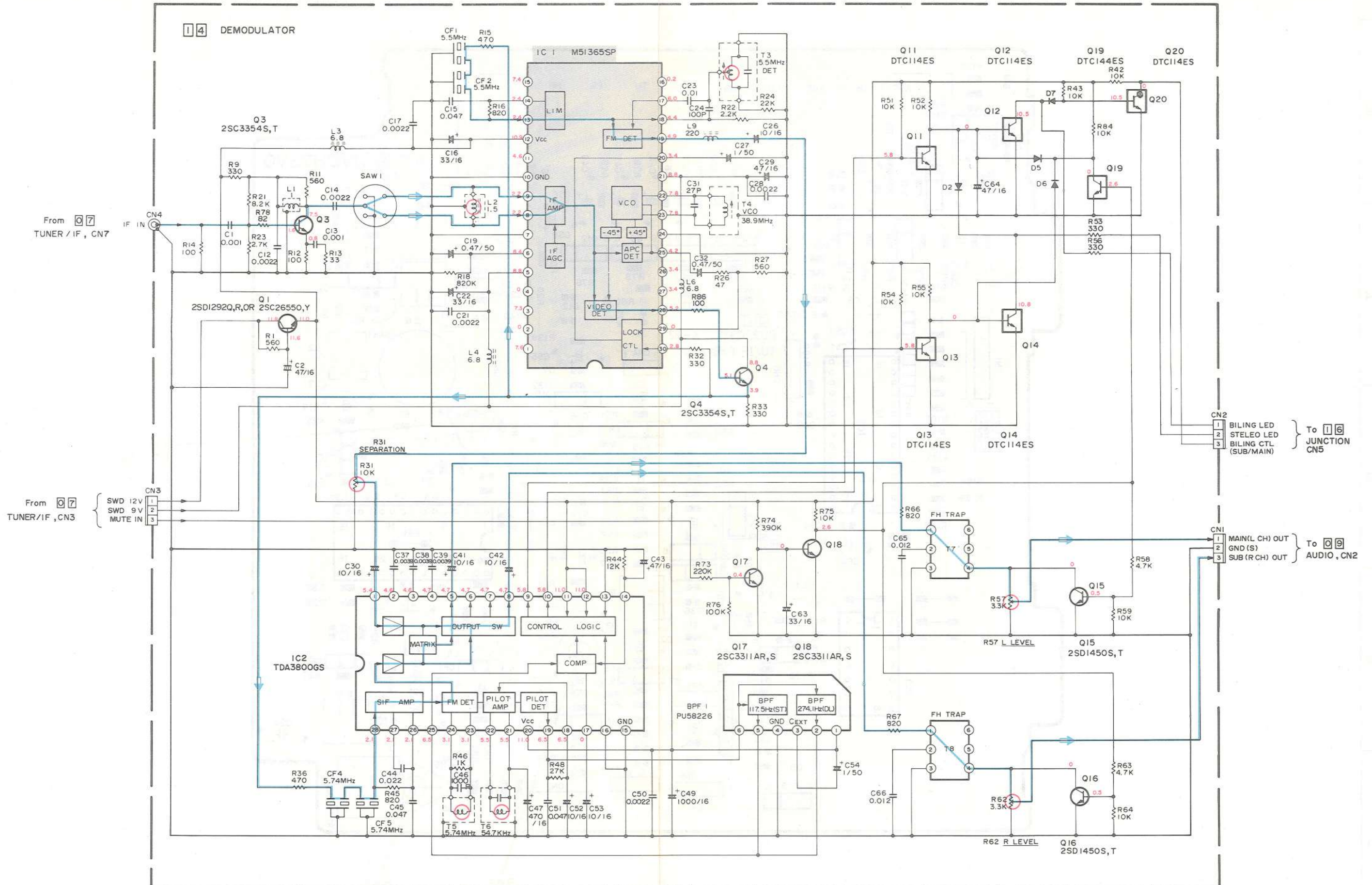
R42
COLOUR
LEVEL

R32
AUDIO
LEVEL

6
5
4
3
2
1

A B C 3-21 3-21 E F G H

3.20 DEMODULATOR SCHEMATIC DIAGRAM (HR-D470E/EG ONLY)

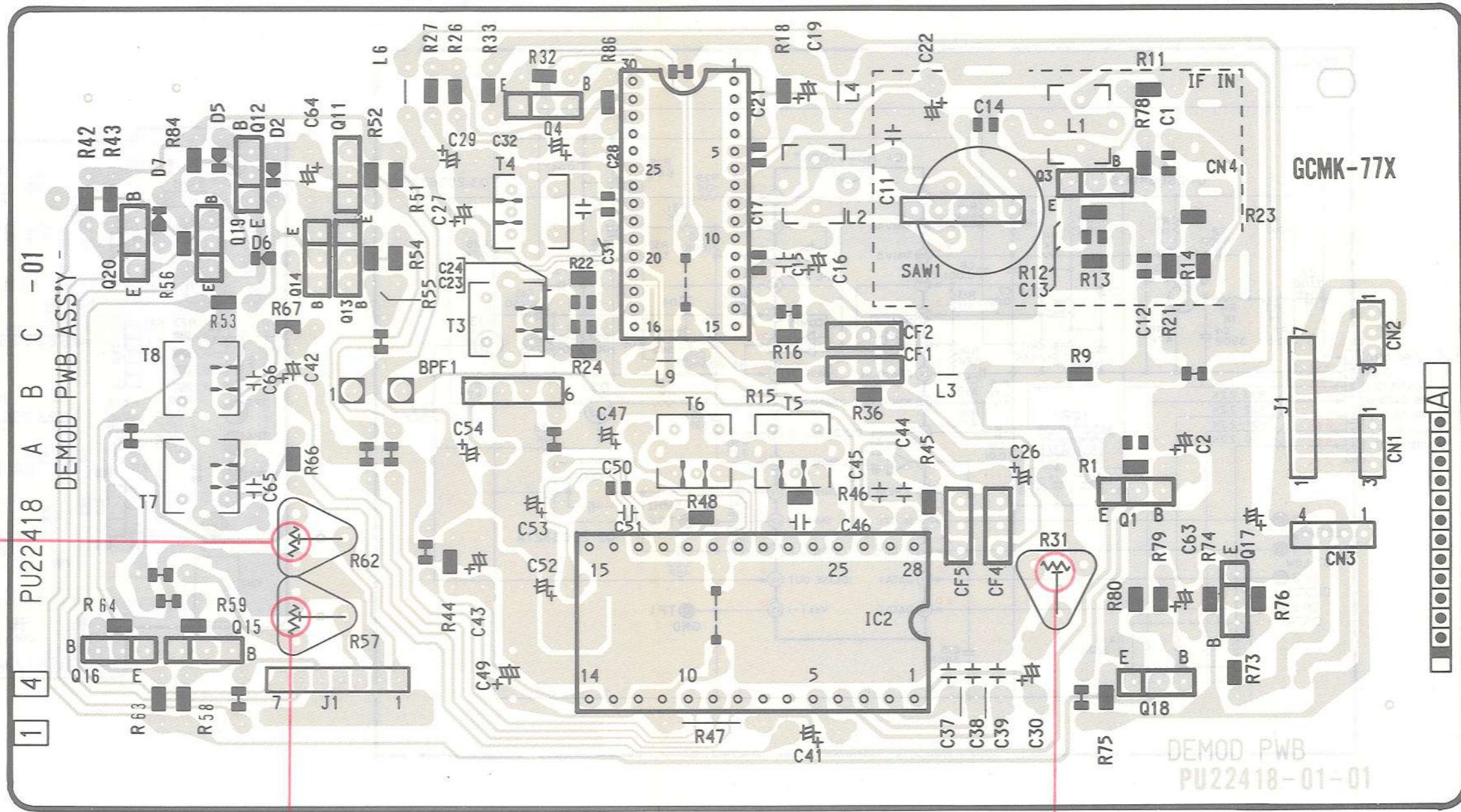


NOTE: Voltages are DC-measured with a digital voltmeter during stop mode.

6
5
4
3
2
1

A B C 3-22 3-22 E F G H

3.21 DEMODULATOR CIRCUIT BOARD (HR-D470E/EG ONLY)



R62
R LEVEL

R57
L LEVEL

R31
SEPARATION

A

B

C

3-23

3-23

E

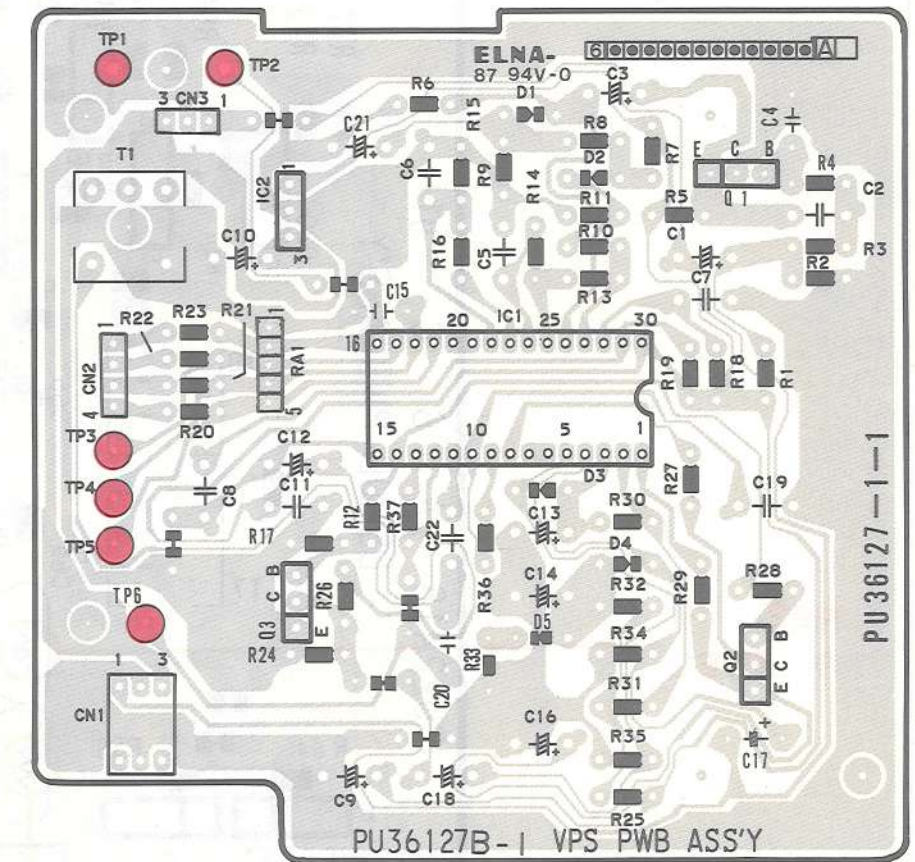
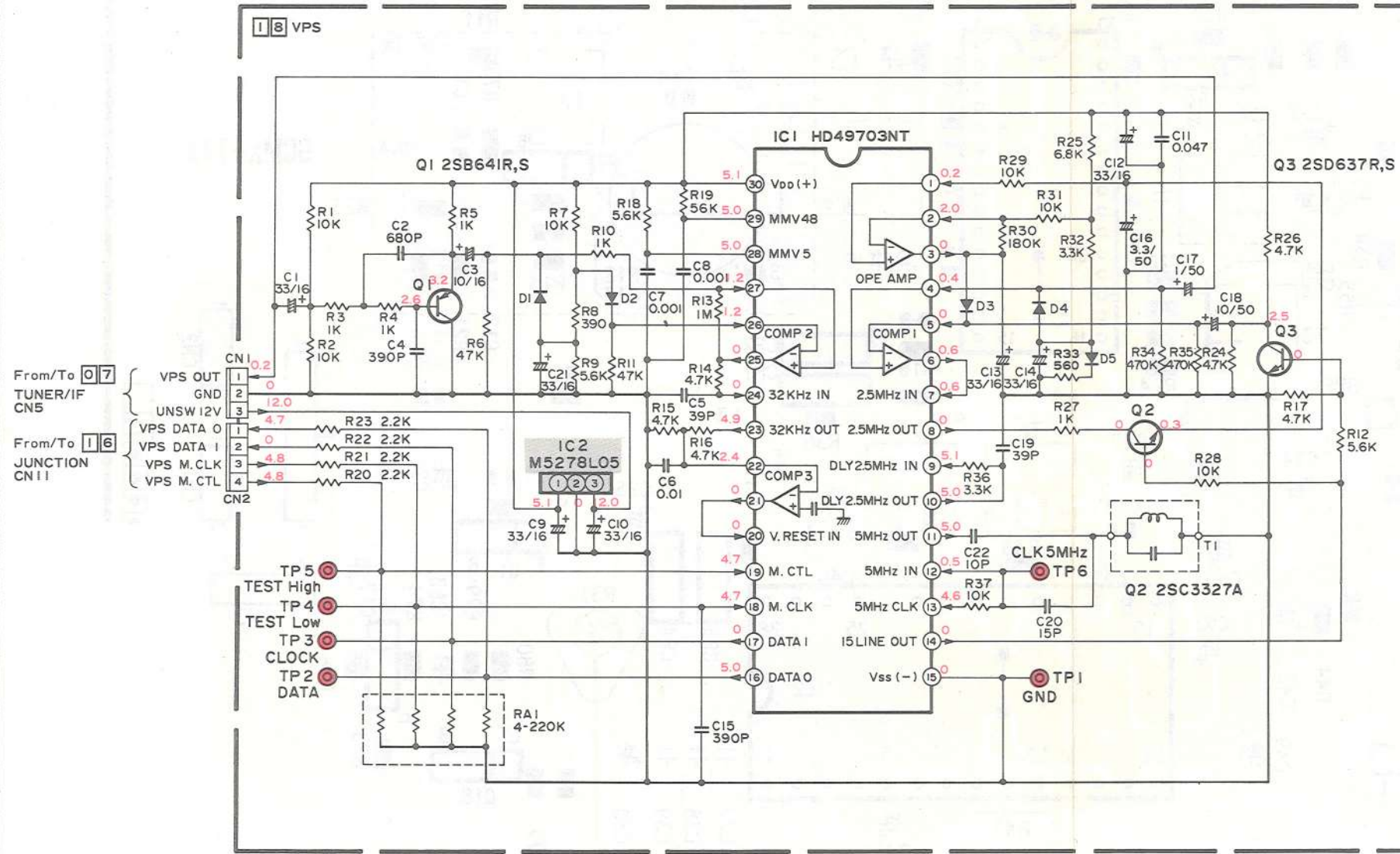
F

G

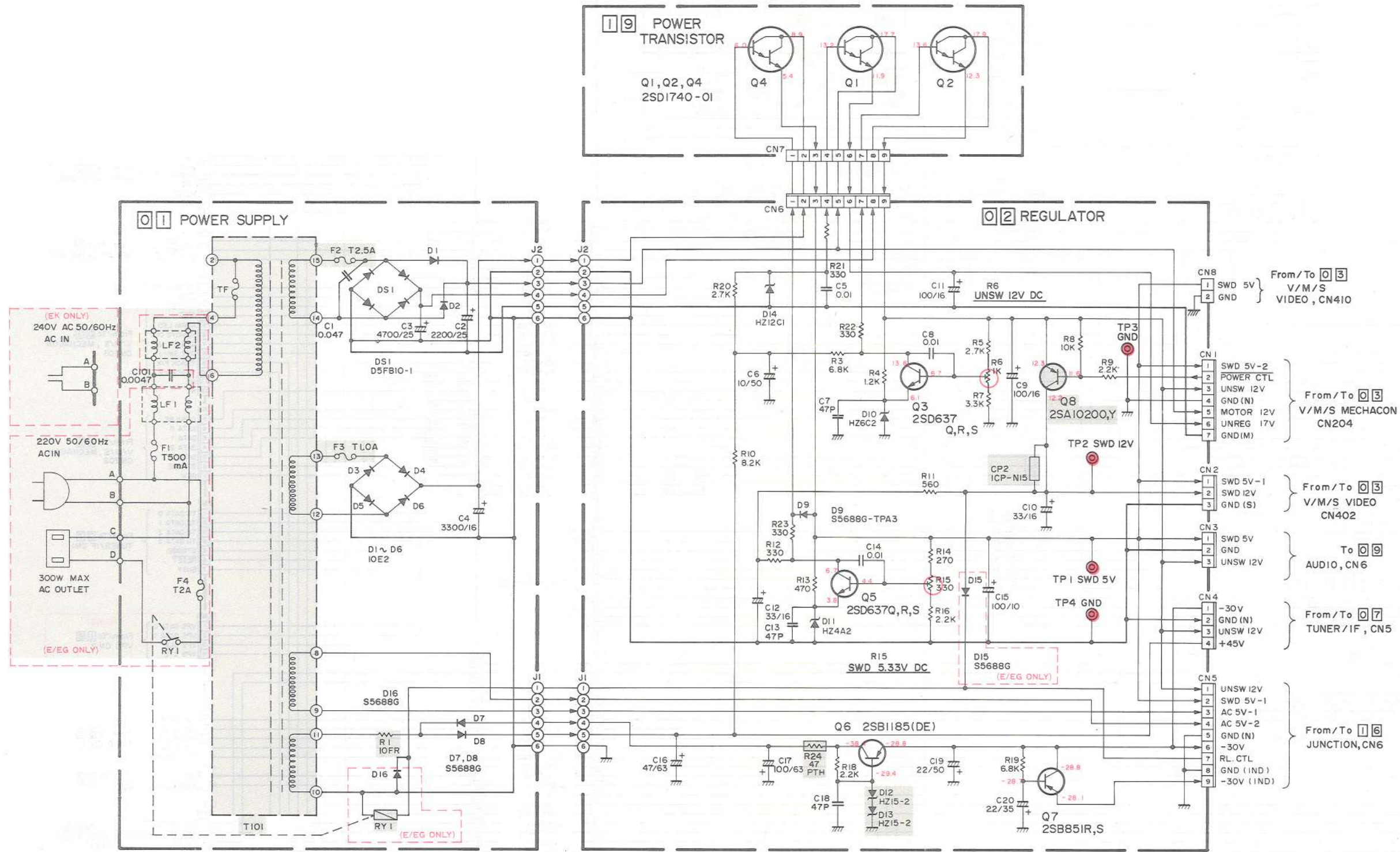
H

3.22 VPS SCHEMATIC DIAGRAM (HR-D470E/EG ONLY)

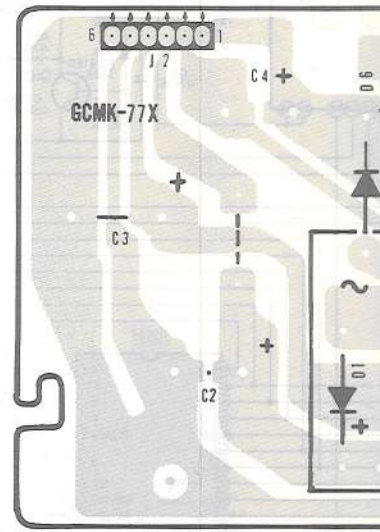
3.23 VPS CIRCUIT BOARD (HR-D470E/EG ONLY)



NOTE: Voltages are DC-measured with a digital voltmeter during stop mode.



NOTE: Voltages are DC-measured with a digital voltmeter during stop mode.



A

B

C

3-25

3-25

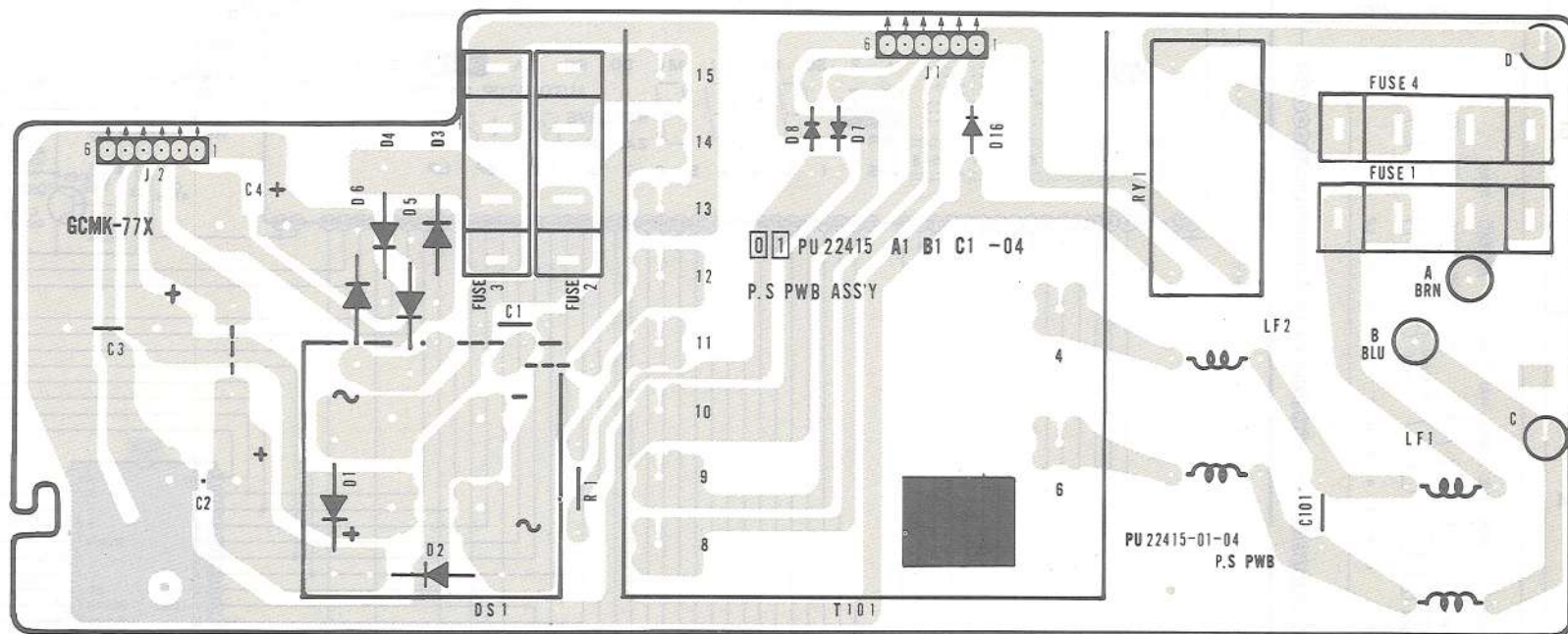
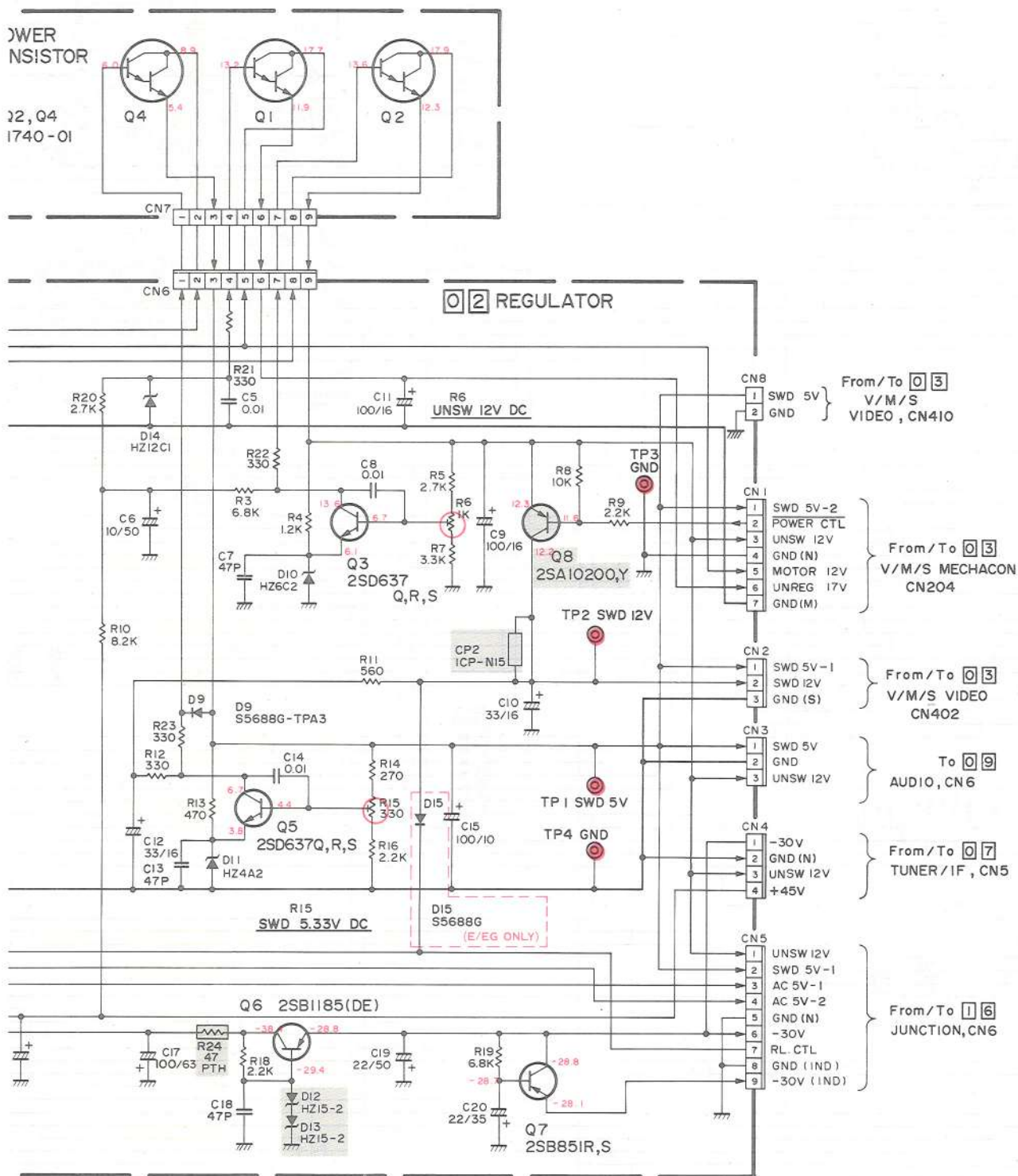
E

F

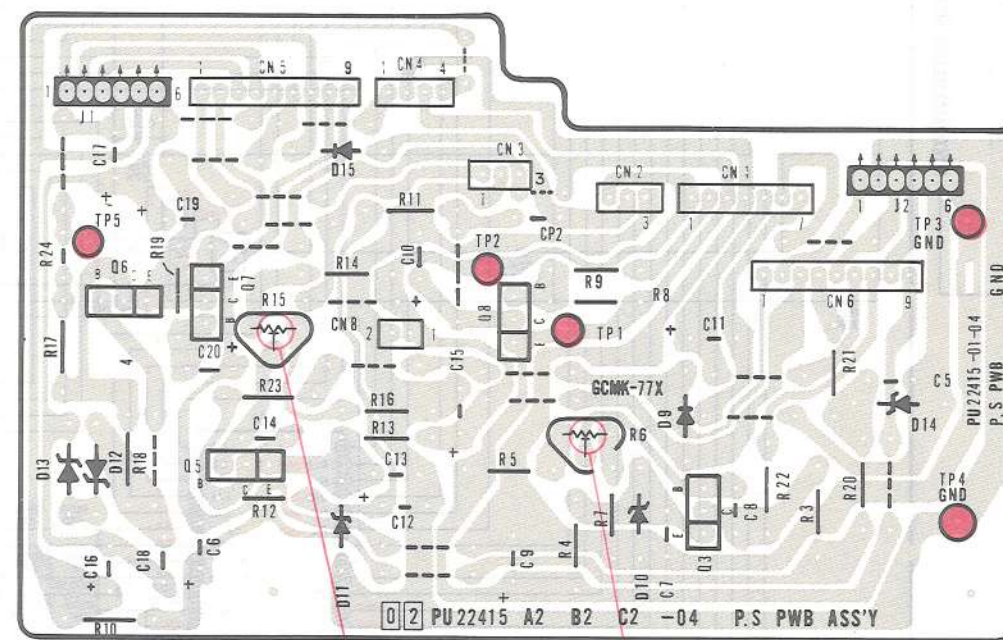
G

H

- POWER TRANSFORMER -



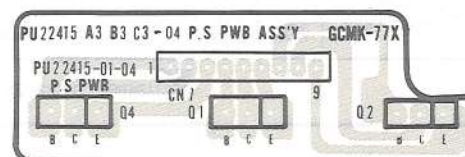
- REGULATOR -



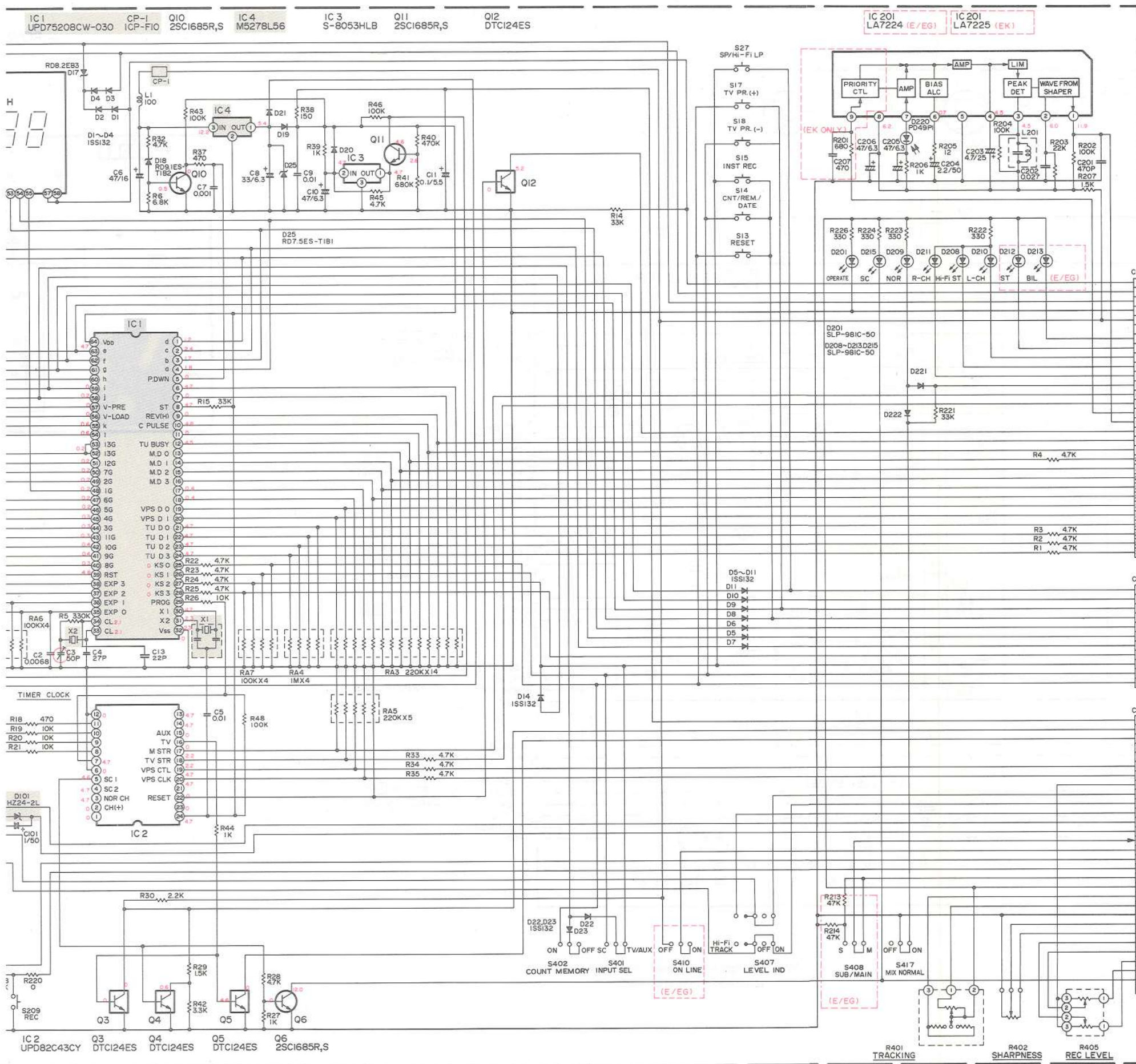
R15
SWD5.33V DC

R6
UNSW 12V DC

- POWER TRANSISTOR -

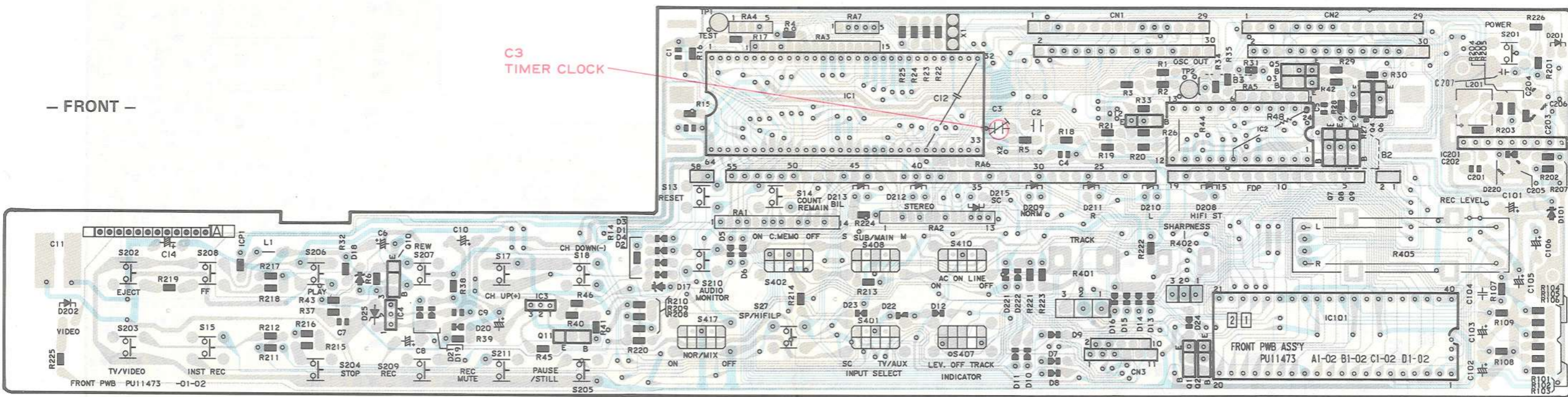


NOTE: Voltages are DC-measured with a digital voltmeter during stop mode.

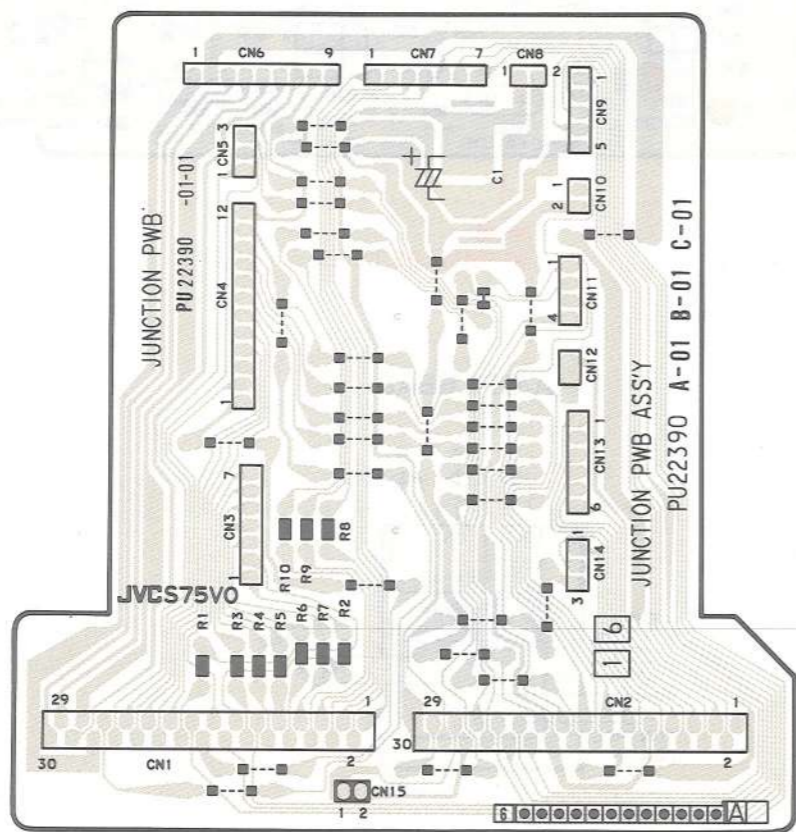


3.27 FRONT, HEADPHONE AND JUNCTION CIRCUIT BOARDS

- FRONT -



- JUNCTION -



- HEADPHONE -



A

B

C

3-27

3-27

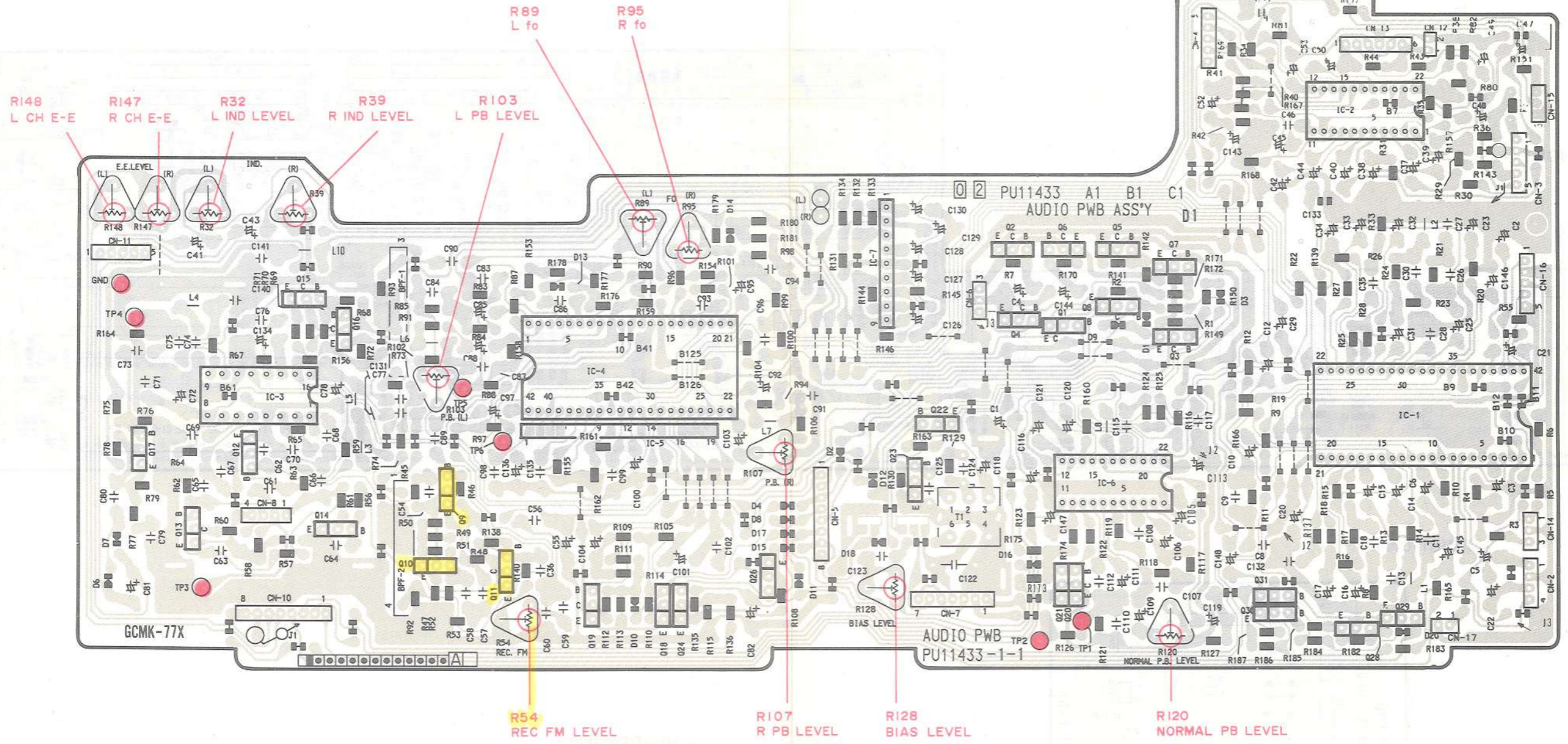
E

F

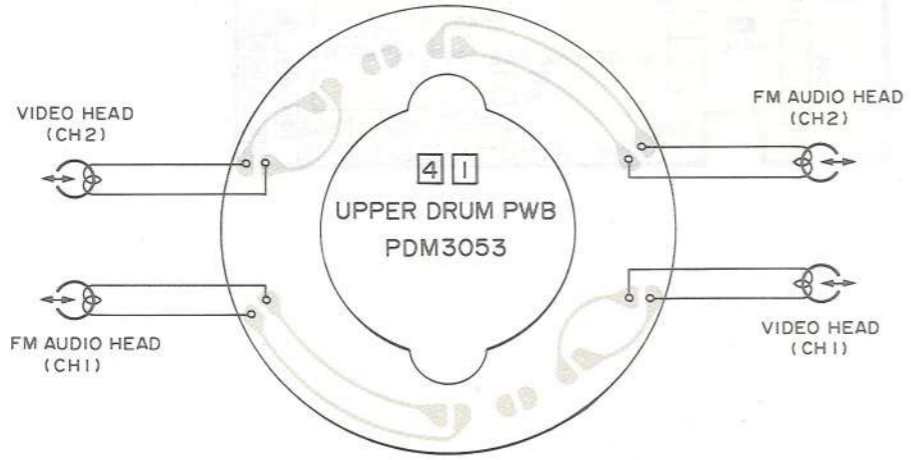
G

H

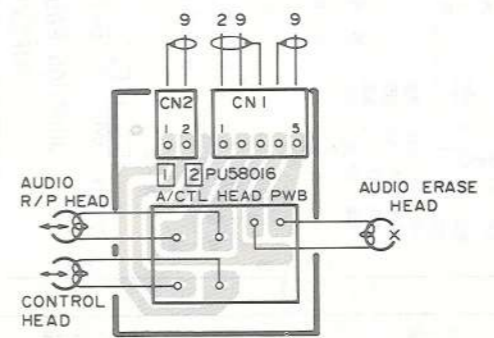
3.28 AUDIO, DECK TERMINAL, LED, RELAY, A/CTL HEAD, REC SAFETY, UPPER DRUM AND END SENSOR CIRCUIT BOARDS



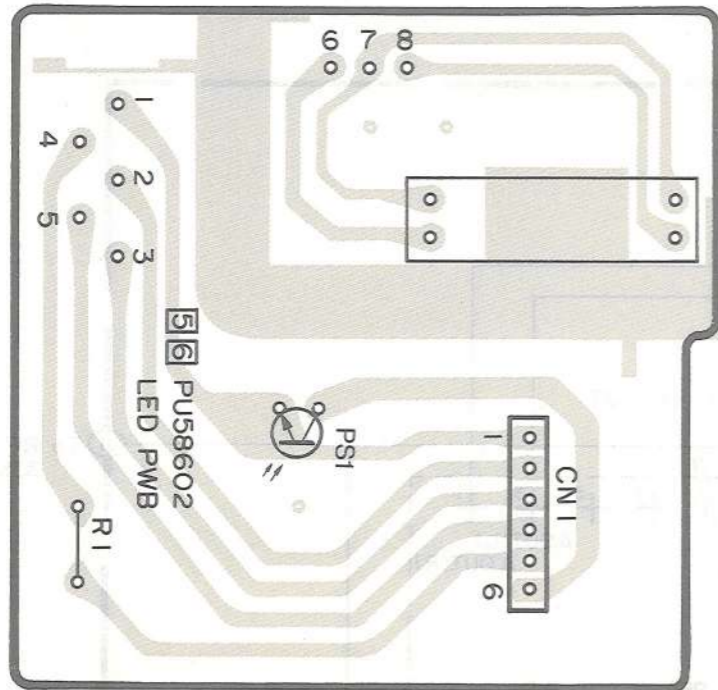
— UPPER DRUM —



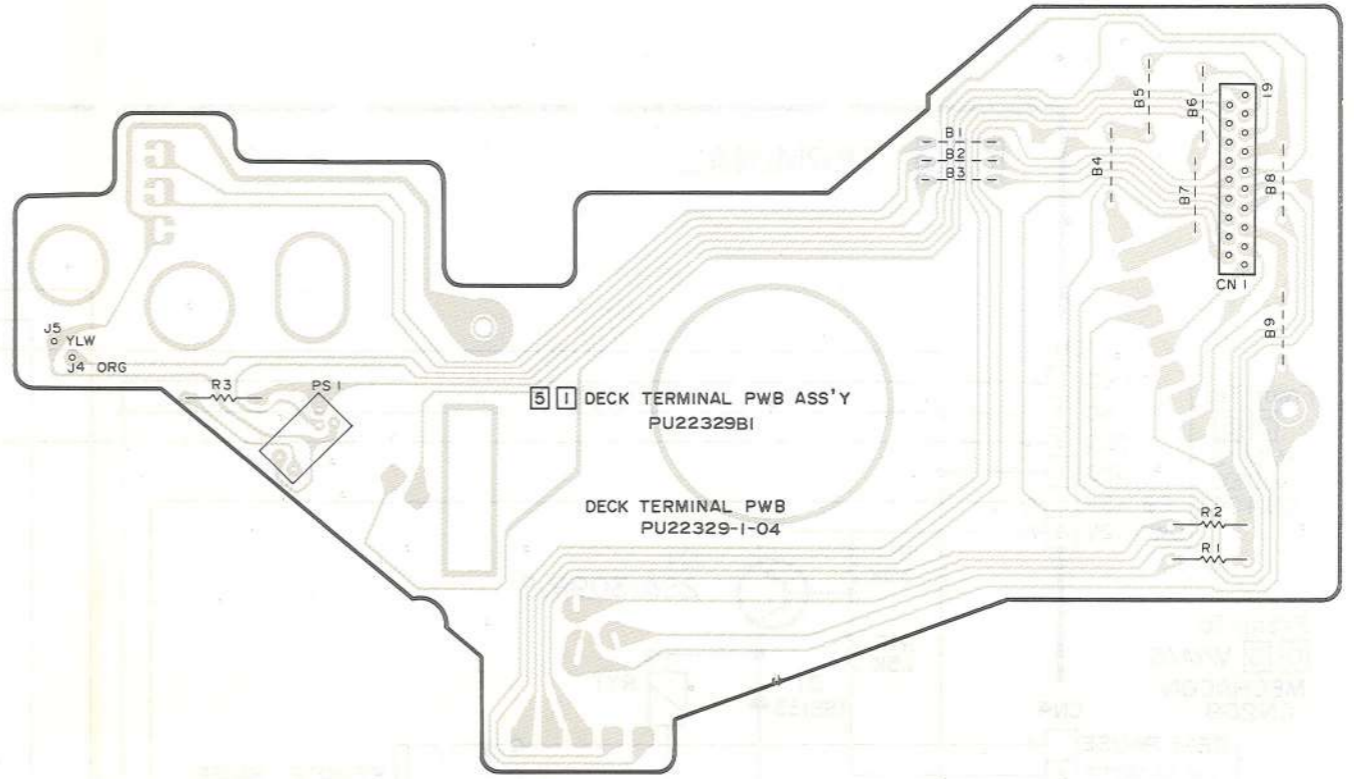
— A/CTL HEAD —



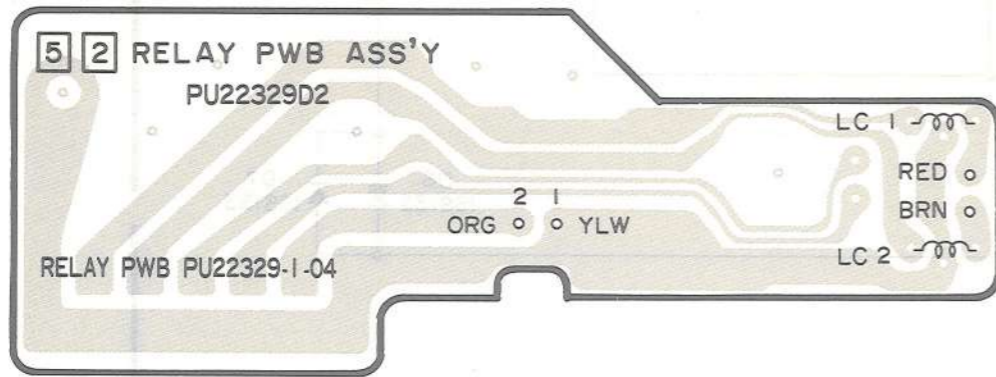
- LED -



- DECK TERMINAL -



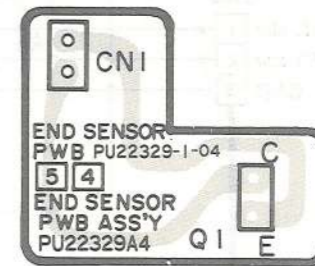
- RELAY -



- REC SAFETY -



- END SENSOR -

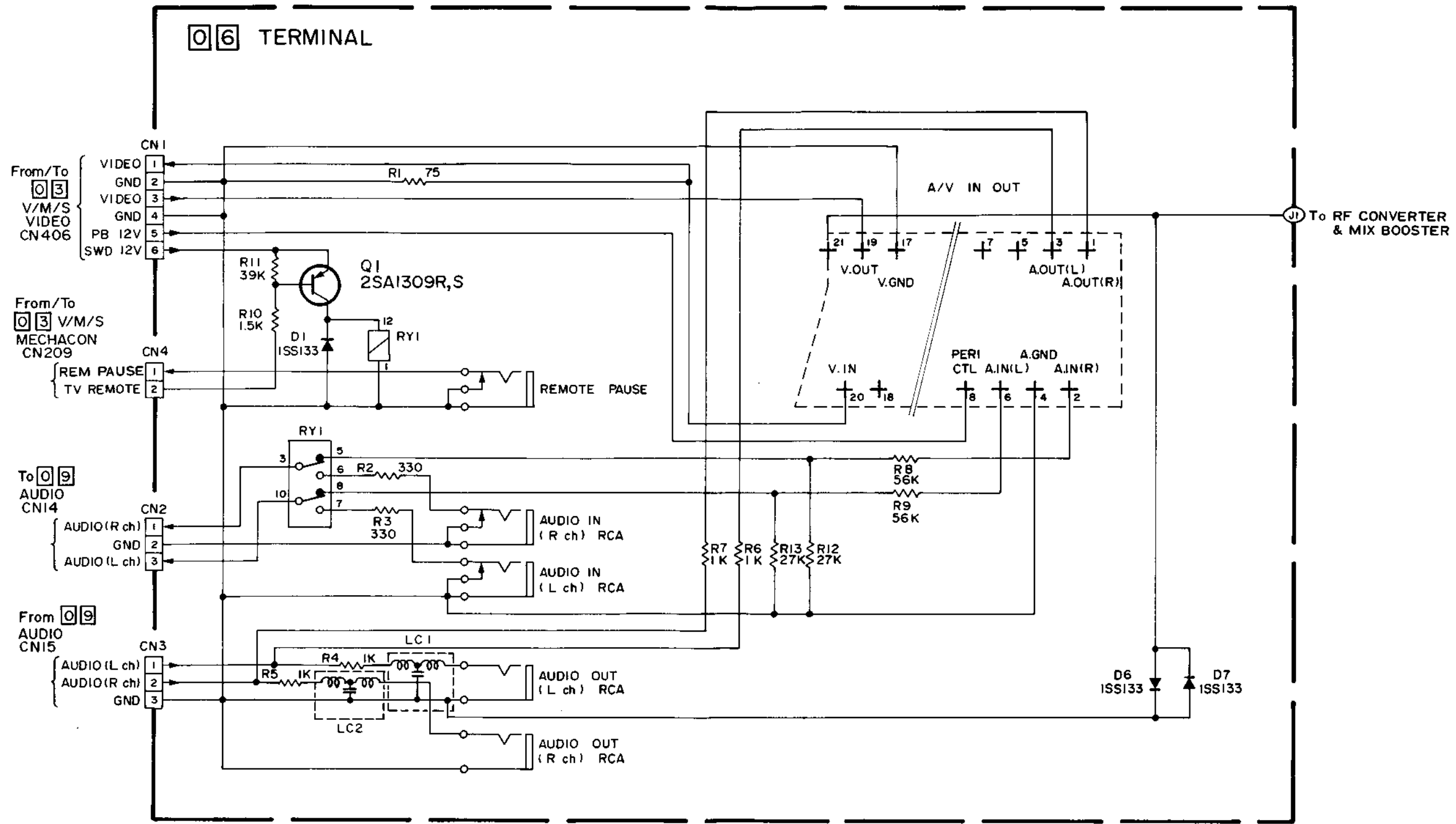


6
5
4
3
2
1

A B C 3-29 3-29 E F G H

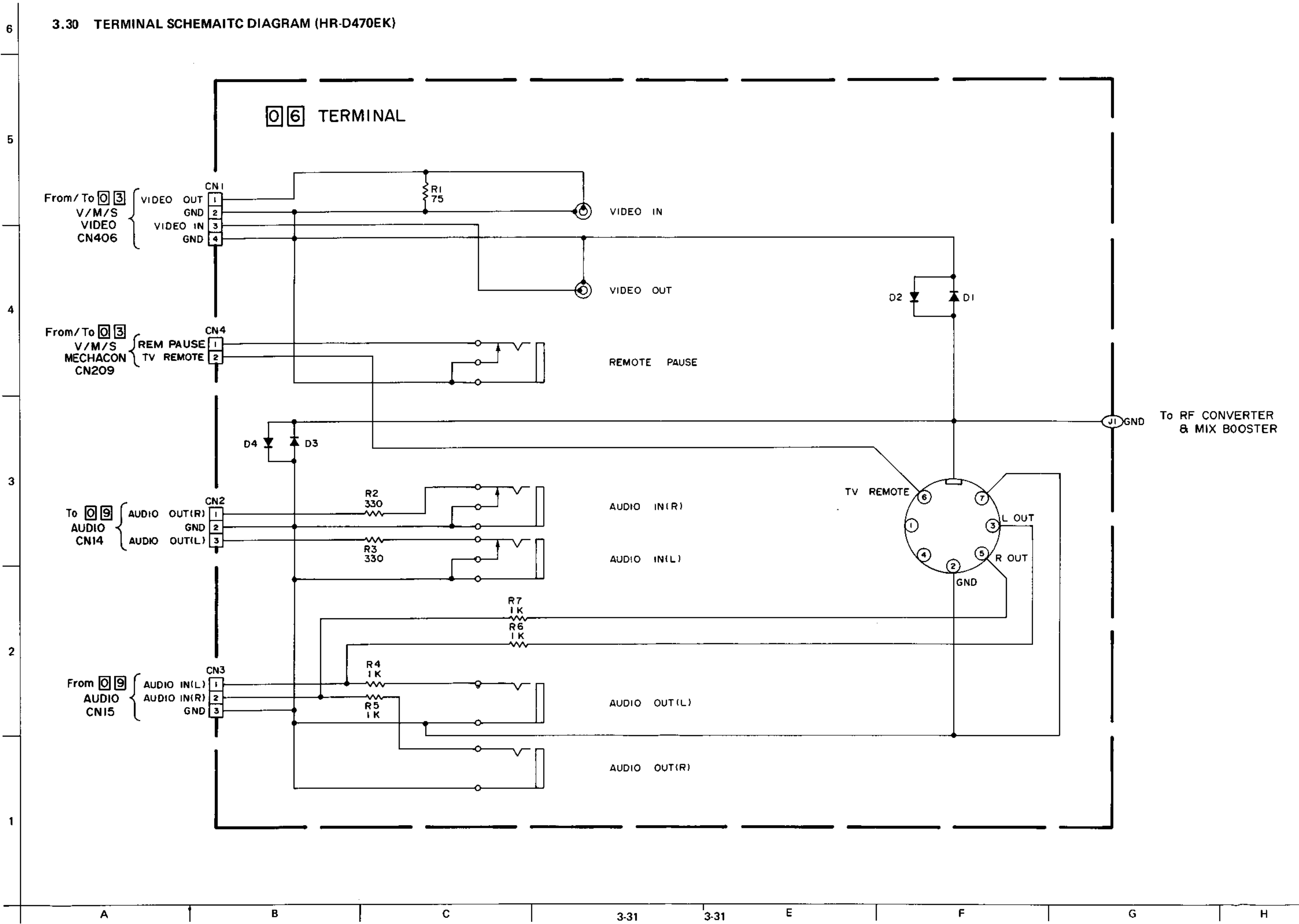
3.29 TERMINAL SCHEMATIC DIAGRAM (HR-D470E/EG)

6
5
4
3
2
1

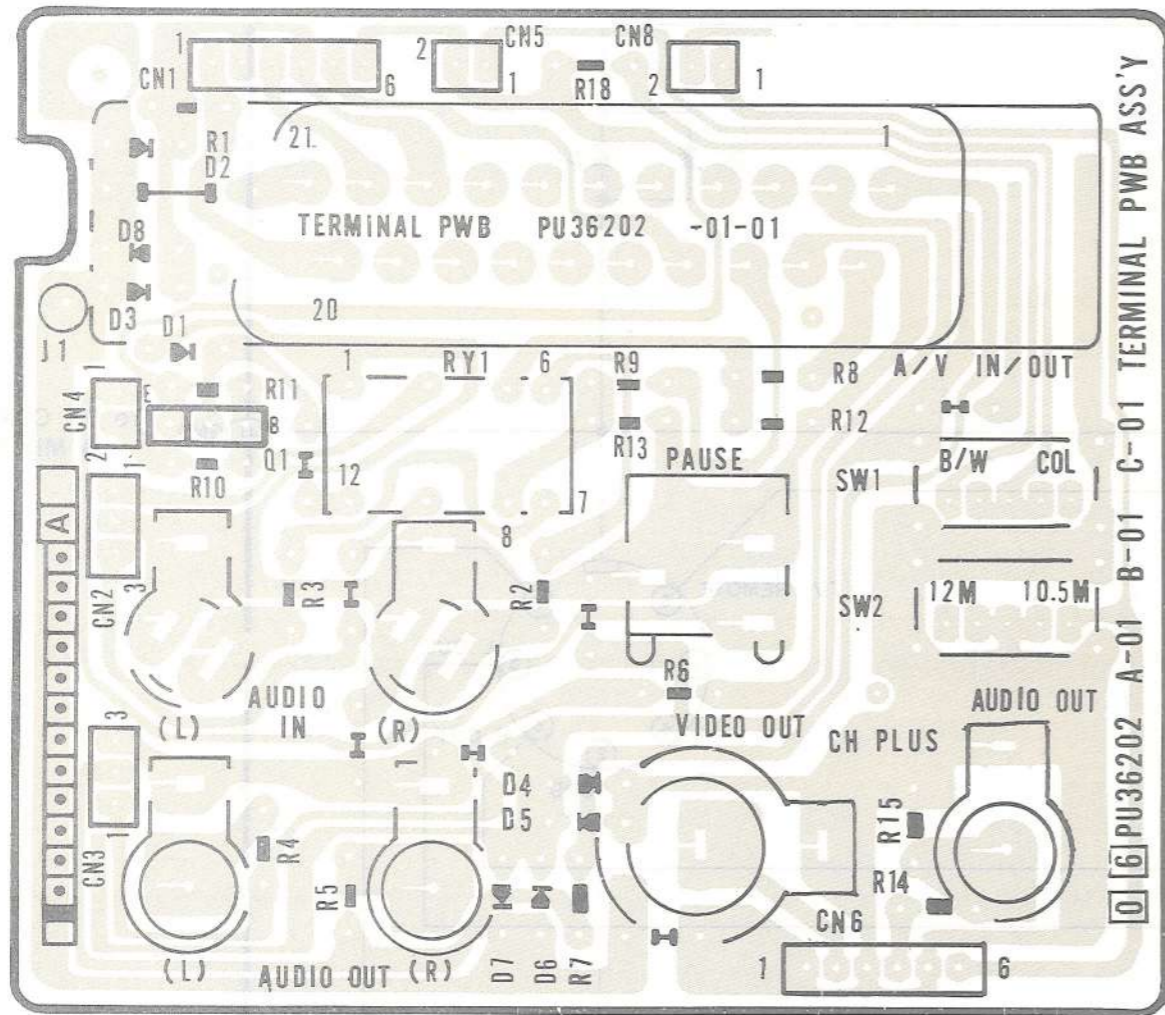


A B C 3-30 3-30 E F G H

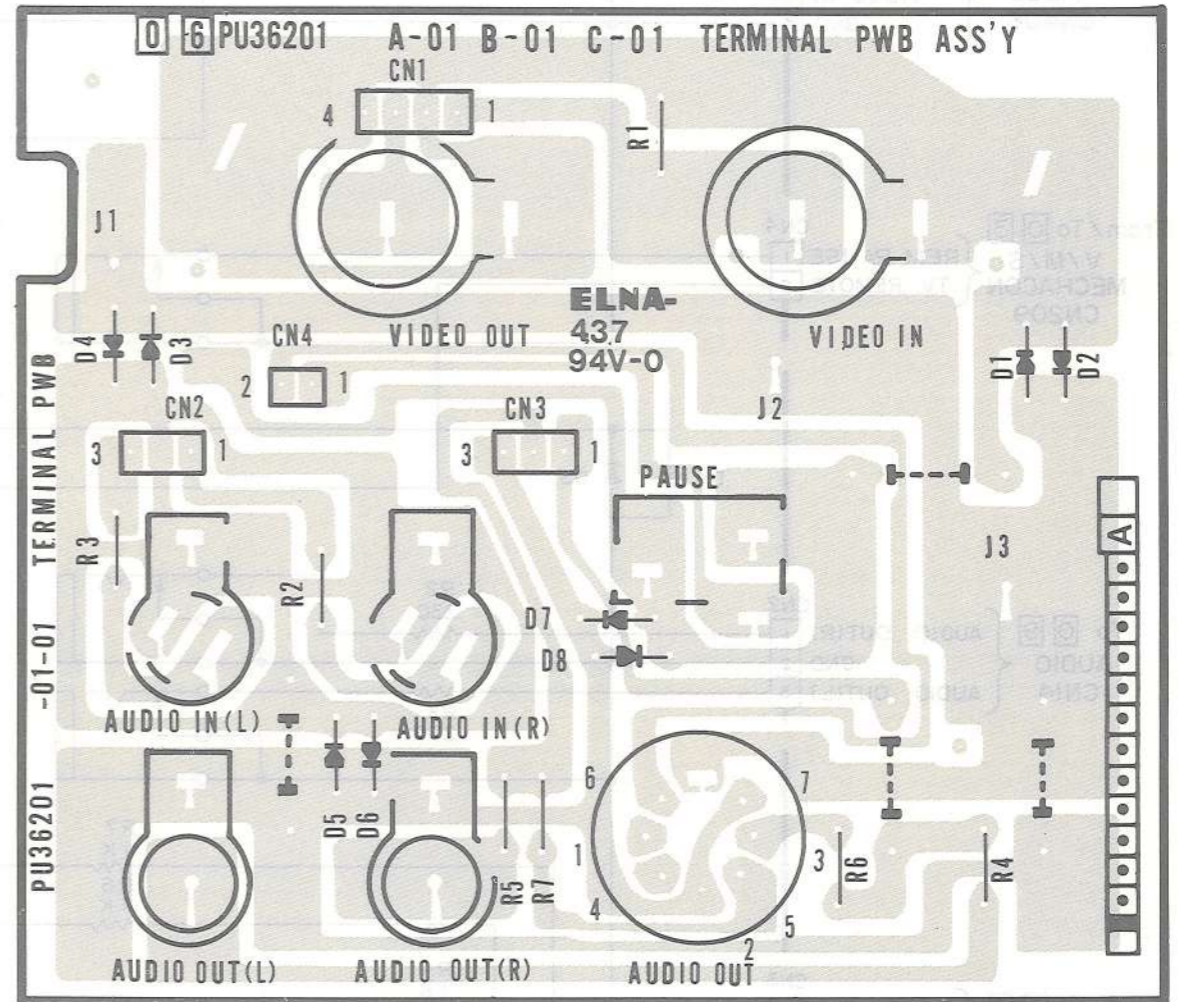
3.30 TERMINAL SCHEMATIC DIAGRAM (HR-D470EK)



- HR-D470E/EG -



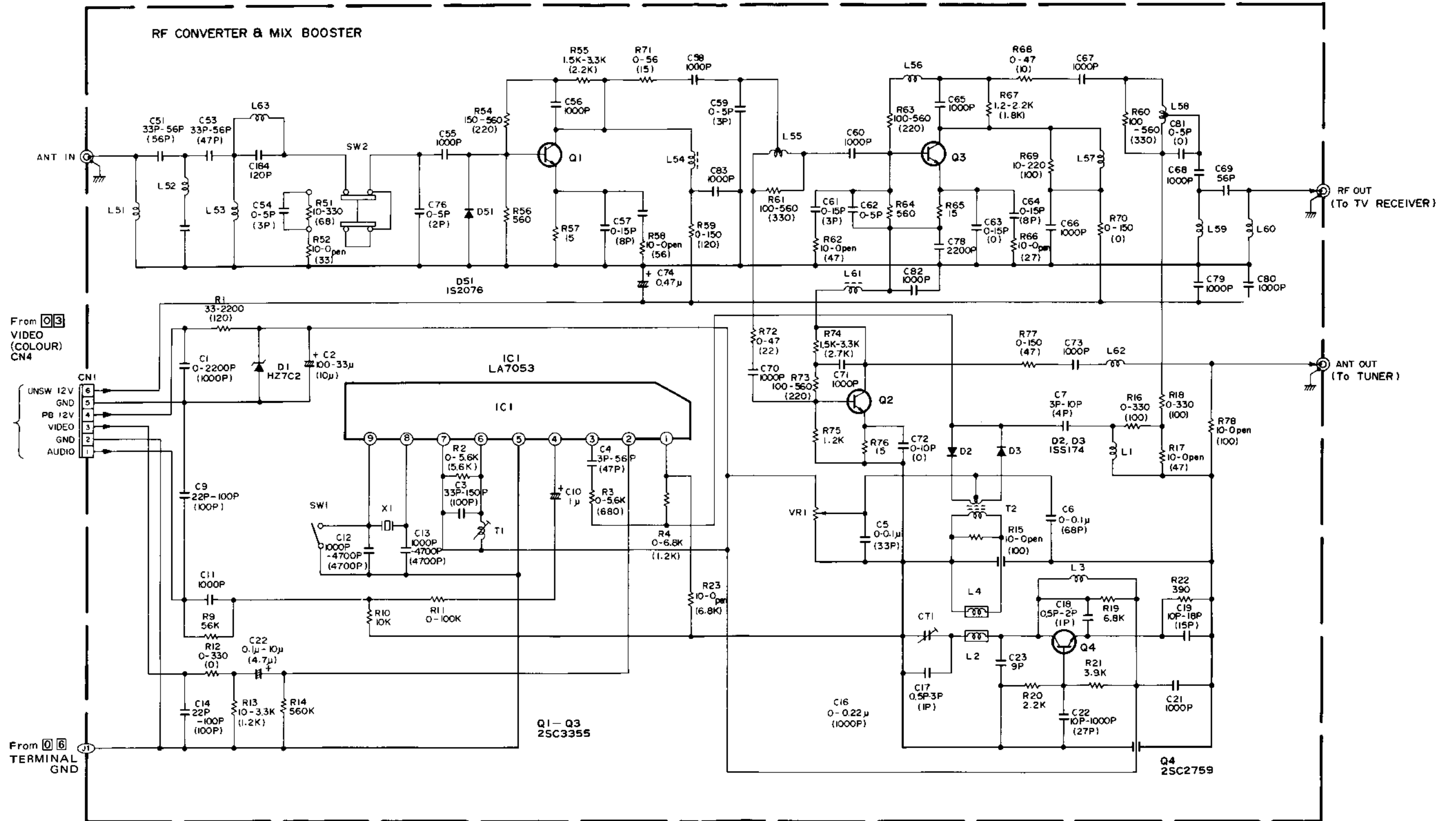
- HR-D470EK -



3.33 RF CONVERTER AND MIX BOOSTER SCHEMATIC DIAGRAM (HR-D470E/EG)

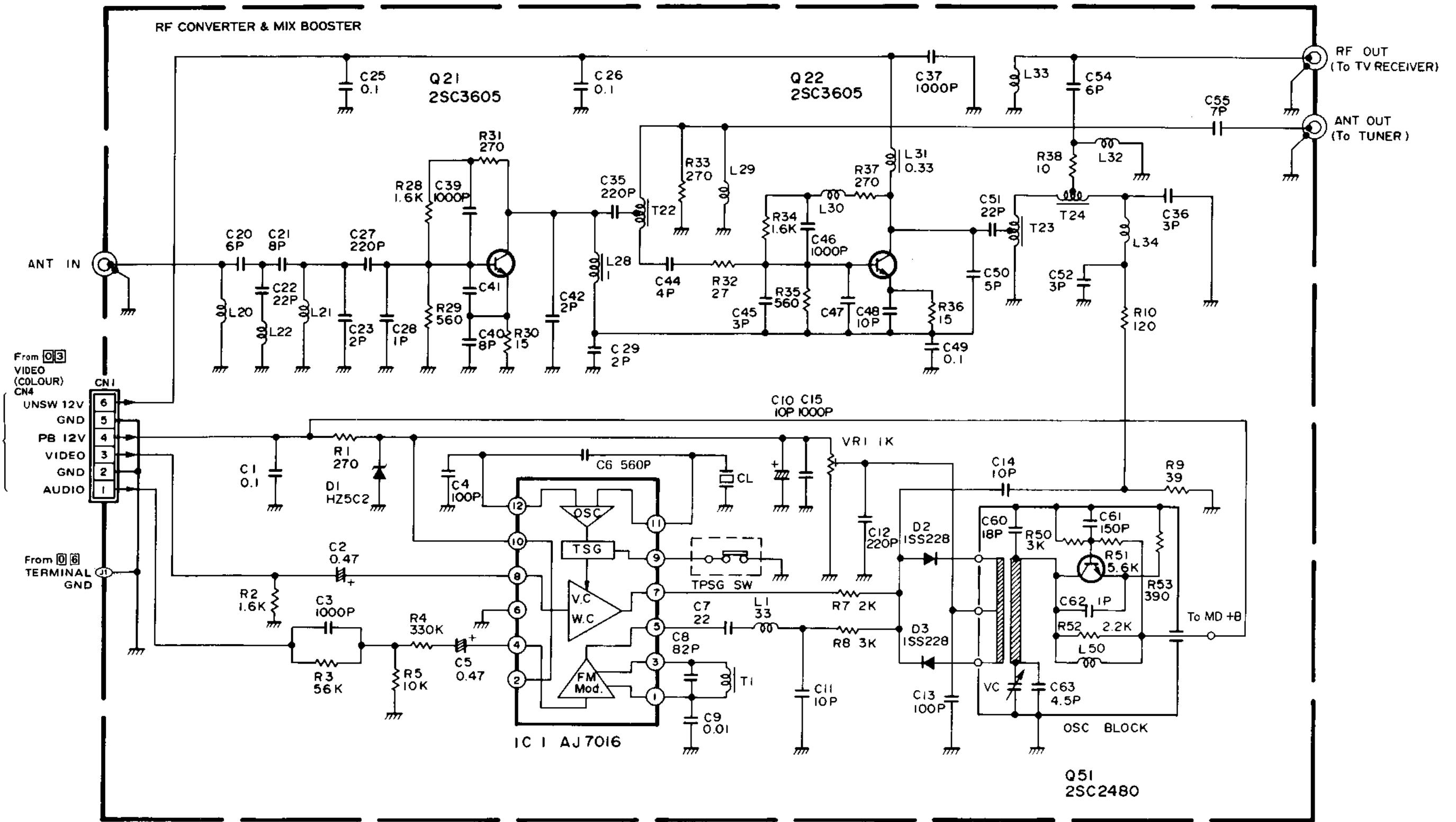
NOTE:

1. All parts shown in this schematic are critical for safety.
2. This schematic is only for reference.
Avoid replacing individual parts.
Replace the entire unit only.



3.34 RF CONVERTER AND MIX BOOSTER SCHEMATIC DIAGRAM (HR-D470EK)

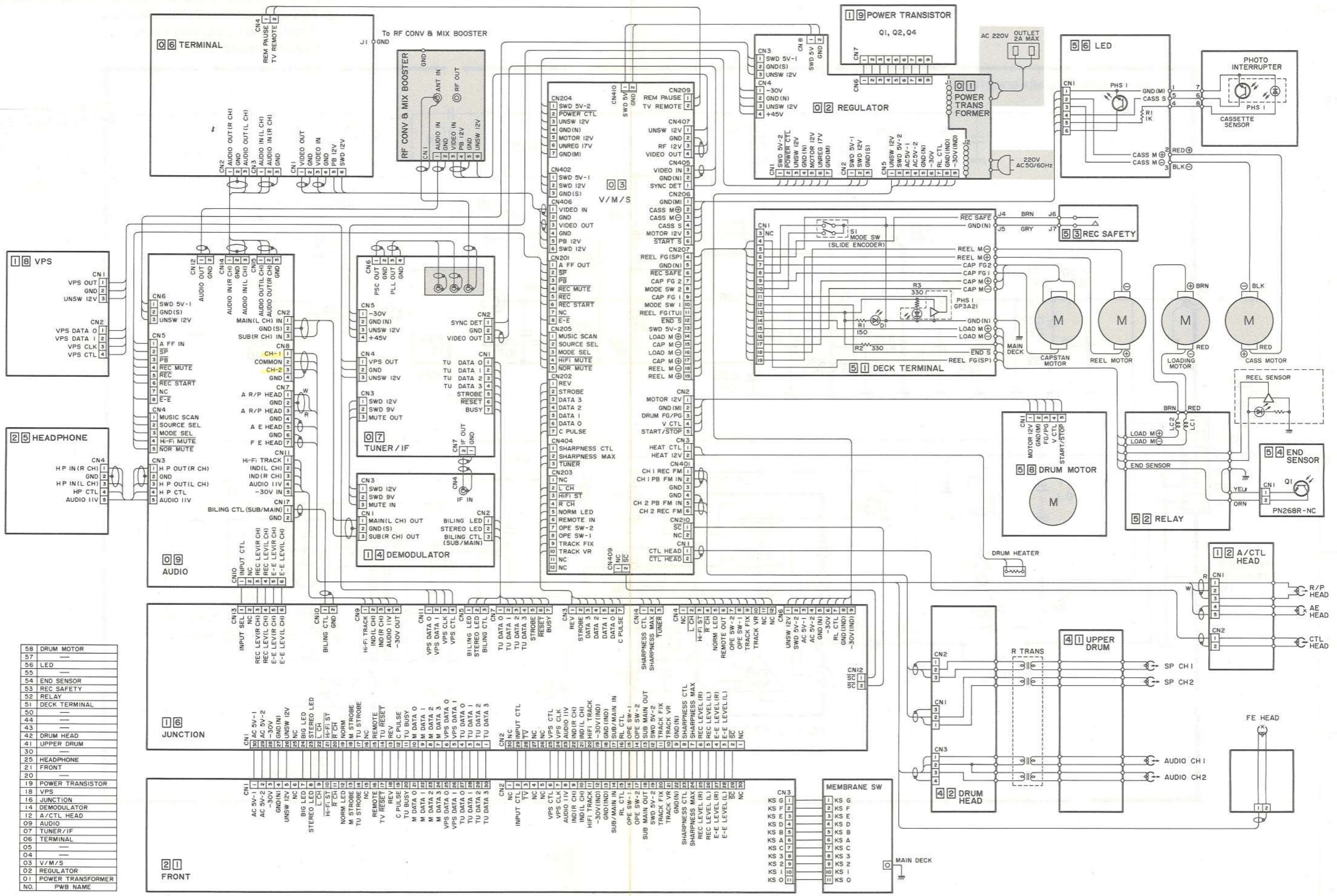
NOTE:
 1. All parts shown in this schematic are critical for safety.
 2. This schematic is only for reference.
 Avoid replacing individual parts.
 Replace the entire unit only.



6
5
4
3
2
1

A B C 3-35 3-35 E F G H

3.35 OVERALL WIRING (HR-D470E/EG)



58	DRUM MOTOR
57	---
56	LED
55	---
54	END SENSOR
53	REC SAFETY
52	RELAY
51	DECK TERMINAL
50	---
49	---
48	DRUM HEAD
47	UPPER DRUM
46	---
45	---
44	---
43	---
42	DRUM HEAD
41	UPPER DRUM
40	---
39	---
38	HEADPHONE
37	FRONT
36	---
35	---
34	---
33	---
32	---
31	---
30	---
29	---
28	---
27	---
26	---
25	HEADPHONE
24	FRONT
23	---
22	---
21	---
20	---
19	POWER TRANSISTOR
18	VPS
17	---
16	JUNCTION
15	---
14	DEMODULATOR
13	---
12	A/CTL HEAD
11	---
10	AUDIO
9	---
8	---
7	TUNER/IF
6	---
5	---
4	---
3	---
2	---
1	---
0	---
NO.	PWB NAME

3.36 OVERALL WIRING (HR-D470EK)

6

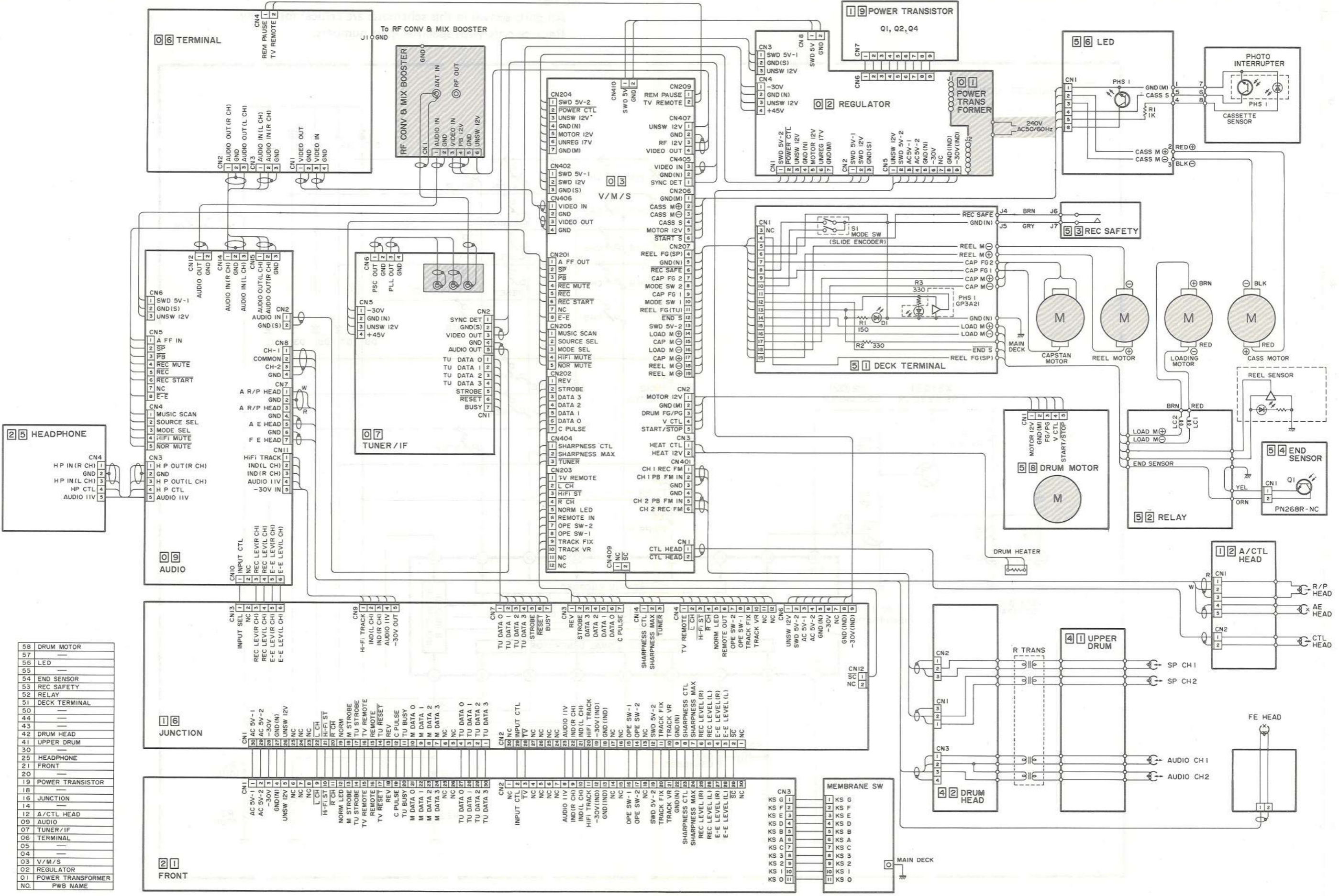
5

4

3

2

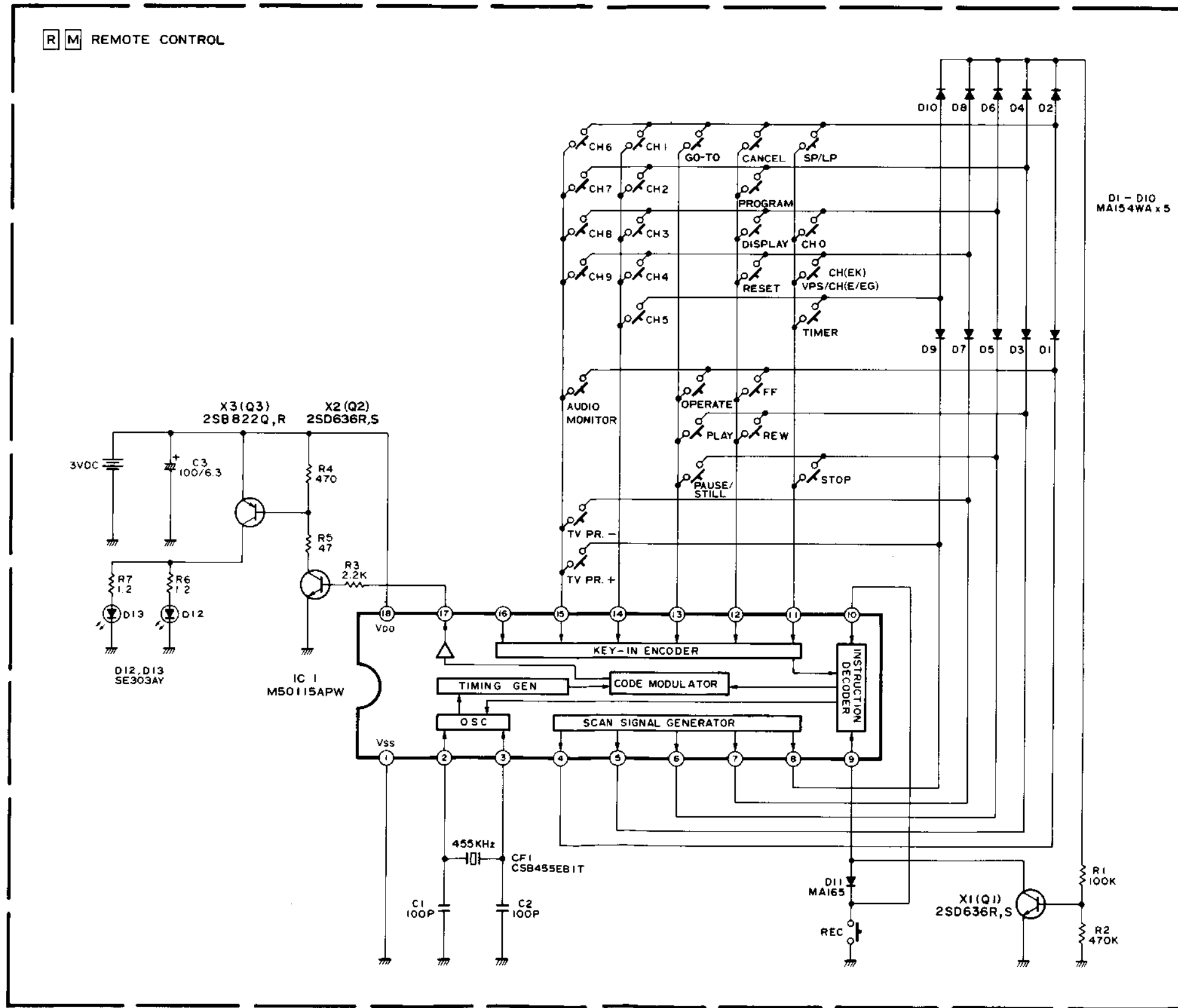
1



NO.	PWB NAME
58	DRUM MOTOR
57	---
56	LED
55	---
54	END SENSOR
53	REC SAFETY
52	RELAY
51	DECK TERMINAL
50	---
44	---
43	---
42	DRUM HEAD
41	UPPER DRUM
30	---
25	HEADPHONE
21	FRONT
20	---
19	POWER TRANSFORMER
18	---
16	JUNCTION
14	---
12	A/CTL HEAD
09	AUDIO
07	TUNER/IF
06	TERMINAL
05	---
04	---
03	V/M/S
02	REGULATOR
01	POWER TRANSFORMER

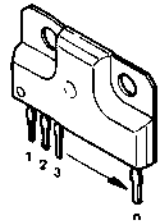
3.37 REMOTE CONTROL SCHEMATIC DIAGRAM

NOTE:
All parts shown in this schematic are critical for safety.
Replace only with specified part numbers.

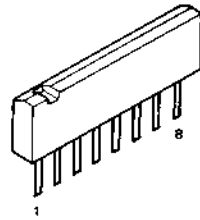


3.38 SEMICONDUCTOR SHAPES

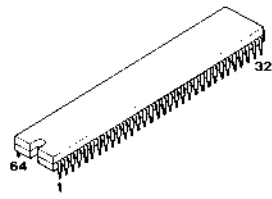
M54644BL
M54644AL



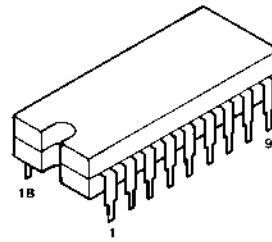
BA7007



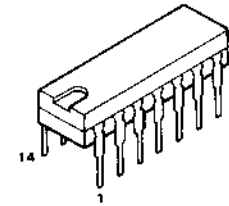
UPD75208CW-030
M50965-611SP



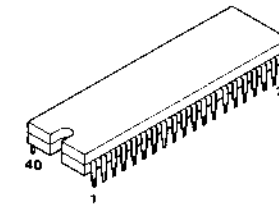
M50115APW



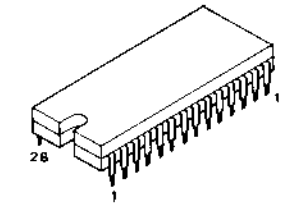
M5224P
BA6405
M58655P



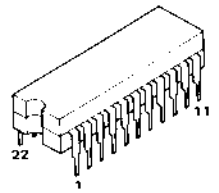
MSC1124BR5



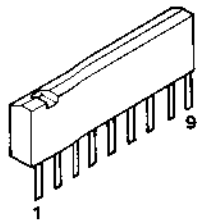
TDA3800GS



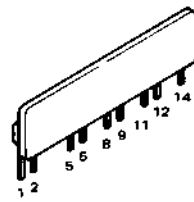
AN3984NK
AN3926K



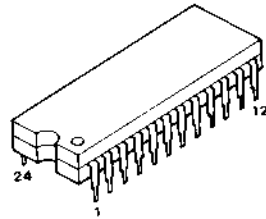
BA3707



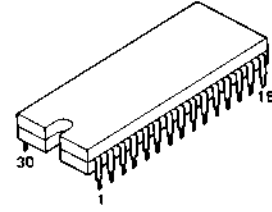
H8D1951A



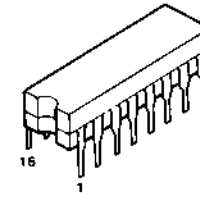
UPD92C43CY



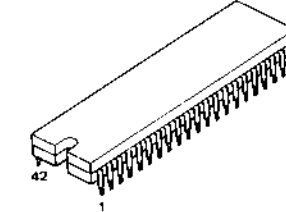
HD49703NT
M50440-394SP
M51365SP
HA11870NT



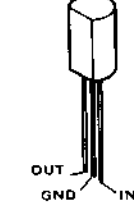
HA11752
TA8400P



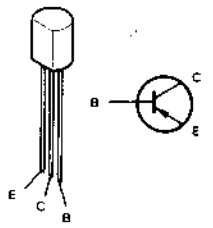
AN6299K
AN3990K
VC2023B



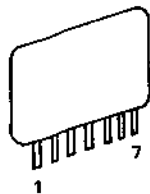
M5278L05
S-8053HLB
M5278L56



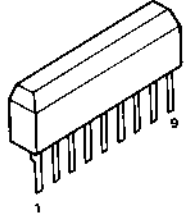
2SA1020Q,Y



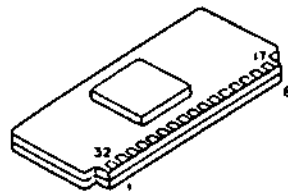
H8D7013
7VT12



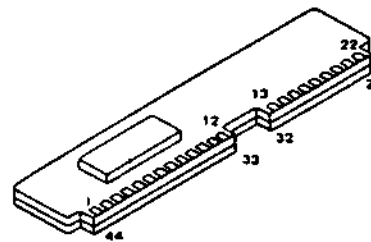
LA7225
LA7224



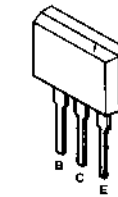
PU22046A



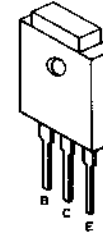
PU22282A



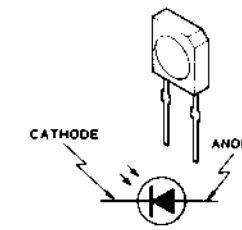
2SB851R,S



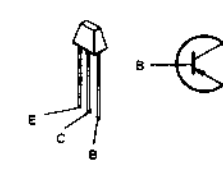
2SD1740-01



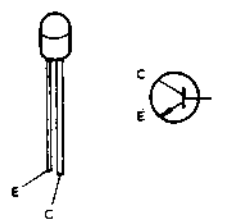
PD49PI



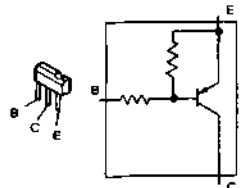
2SA933
2A854
2SA1309



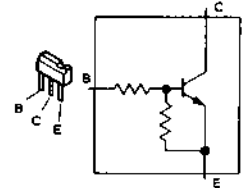
PN268R-NC



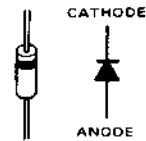
DTA143
DTA114
DTA124
DTA144



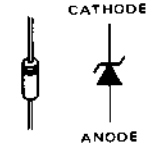
DTC144
DTC124



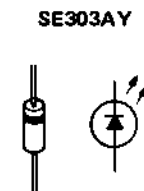
E-452-2
S5688G
11E2
1SS132
MA27TA
10E2
1SS133
MA165
OA90



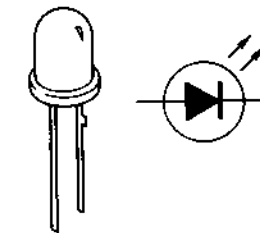
RD8.2EB3
HZ12C1
HZ15-2
HZ4A2
HZ6C2
HZS4.3EB2
HZ30-2
RD7.5ES-R1B1
RD6.2ES-T1B1



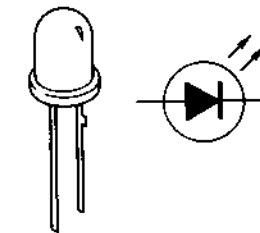
MTZ6.8B
MTZ10A
MTZ5.1C
HZ24-2L
RD5.6ES-T1B1
MTZ10B
MTZ7.5B
MTZ12B
RD9.1ES-T1B2



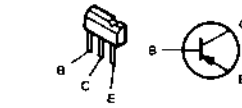
SE303AY



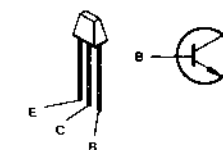
SLP-981C-50



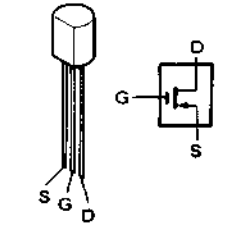
2SB1185
2SB851
2SB810
2SB641
2SB643



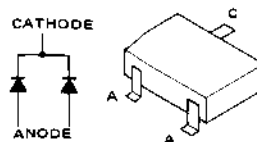
2SD1450
2SC1740
2SC3354
2SC1741
2SC3327



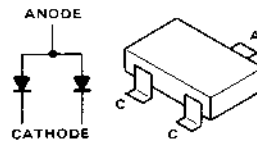
2SK656



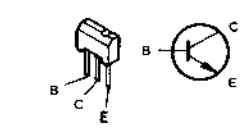
DAN209S



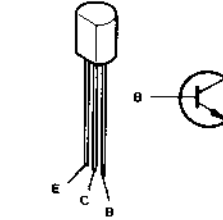
MA154WA



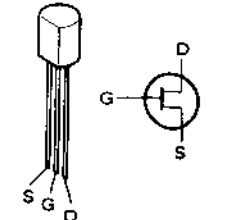
2SD638
2SD637
2SD636
2SC2021



2SD973
2SD1292
2SC2655
2SC1685

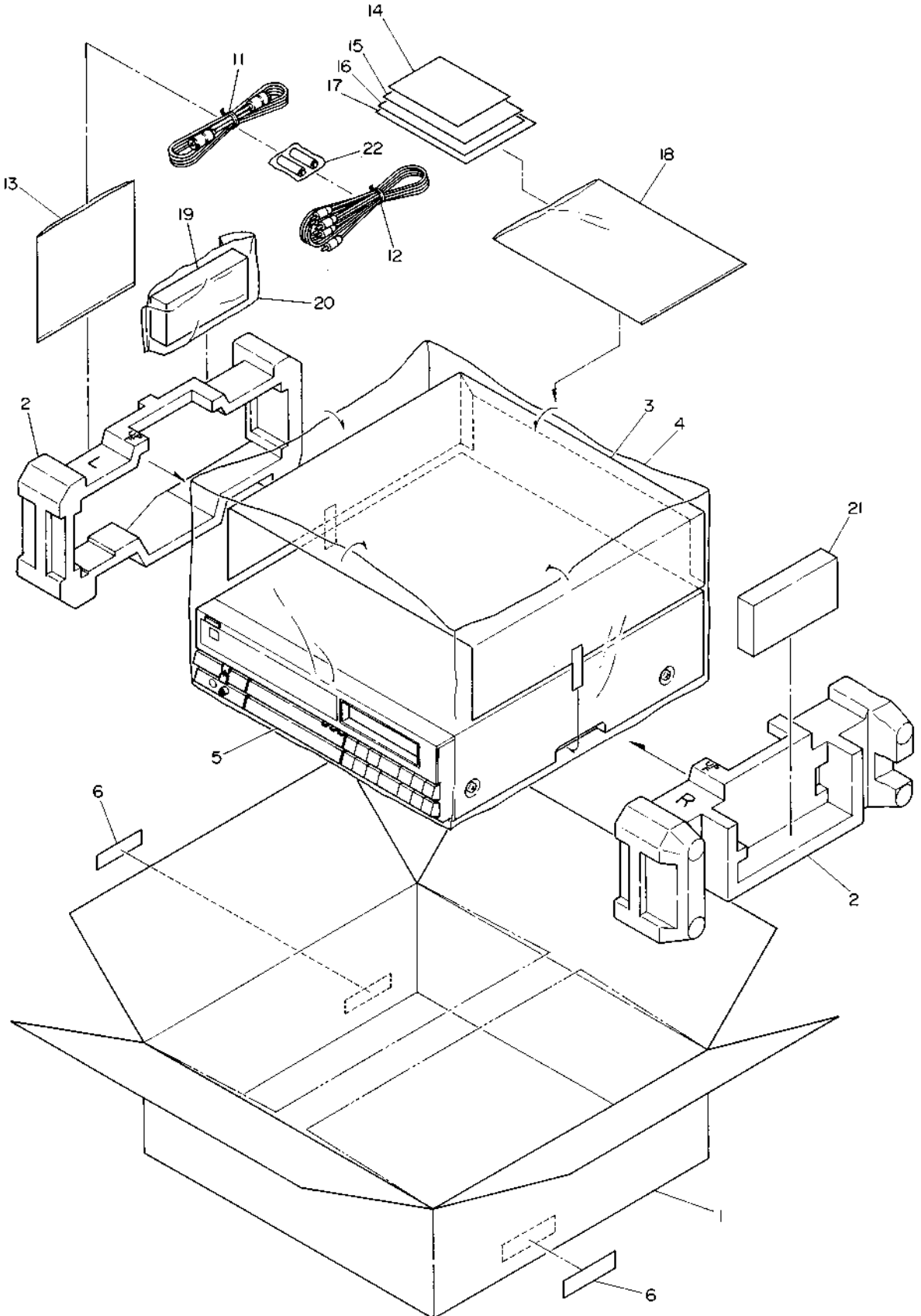


2SK381

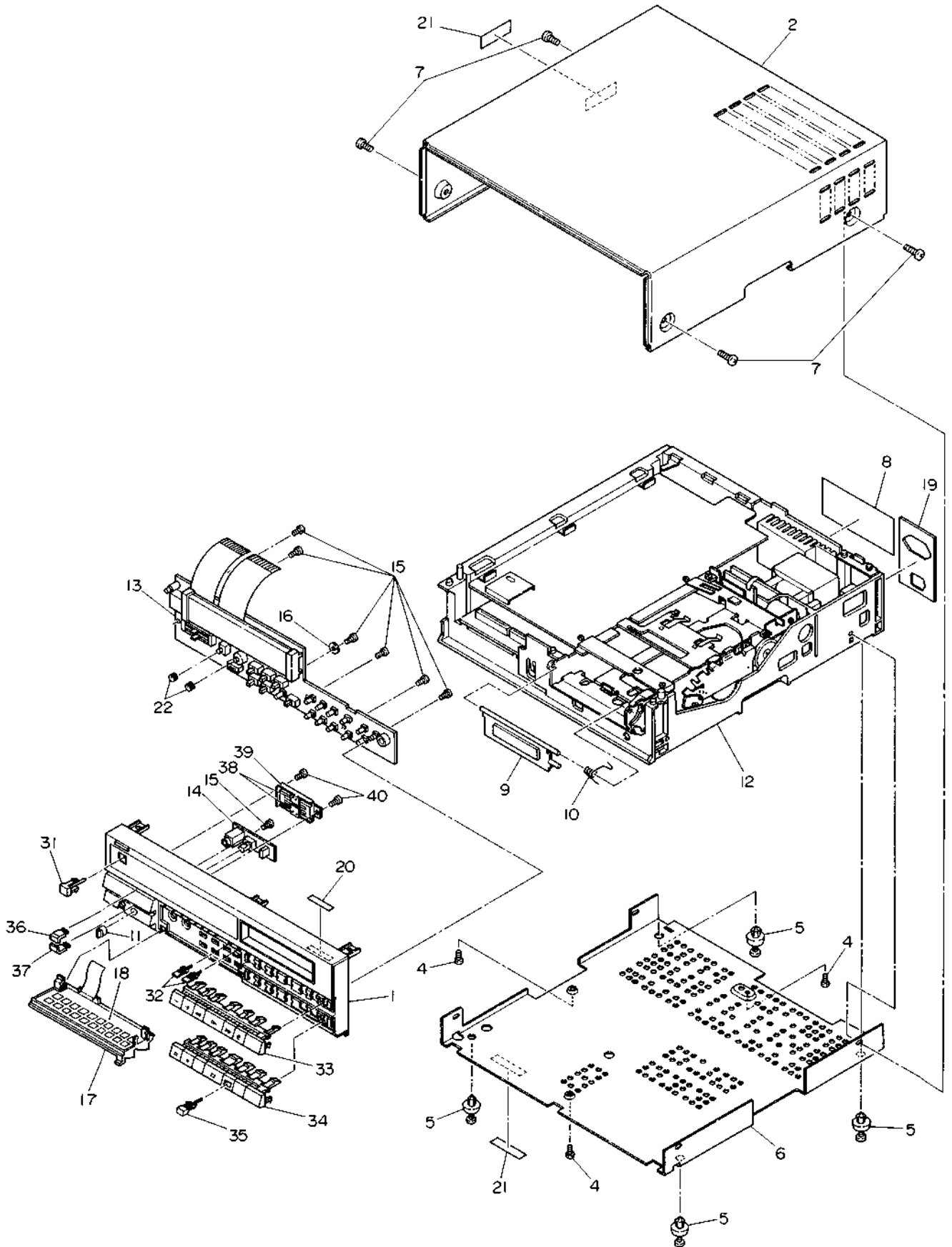


SECTION 4 EXPLODED VIEWS

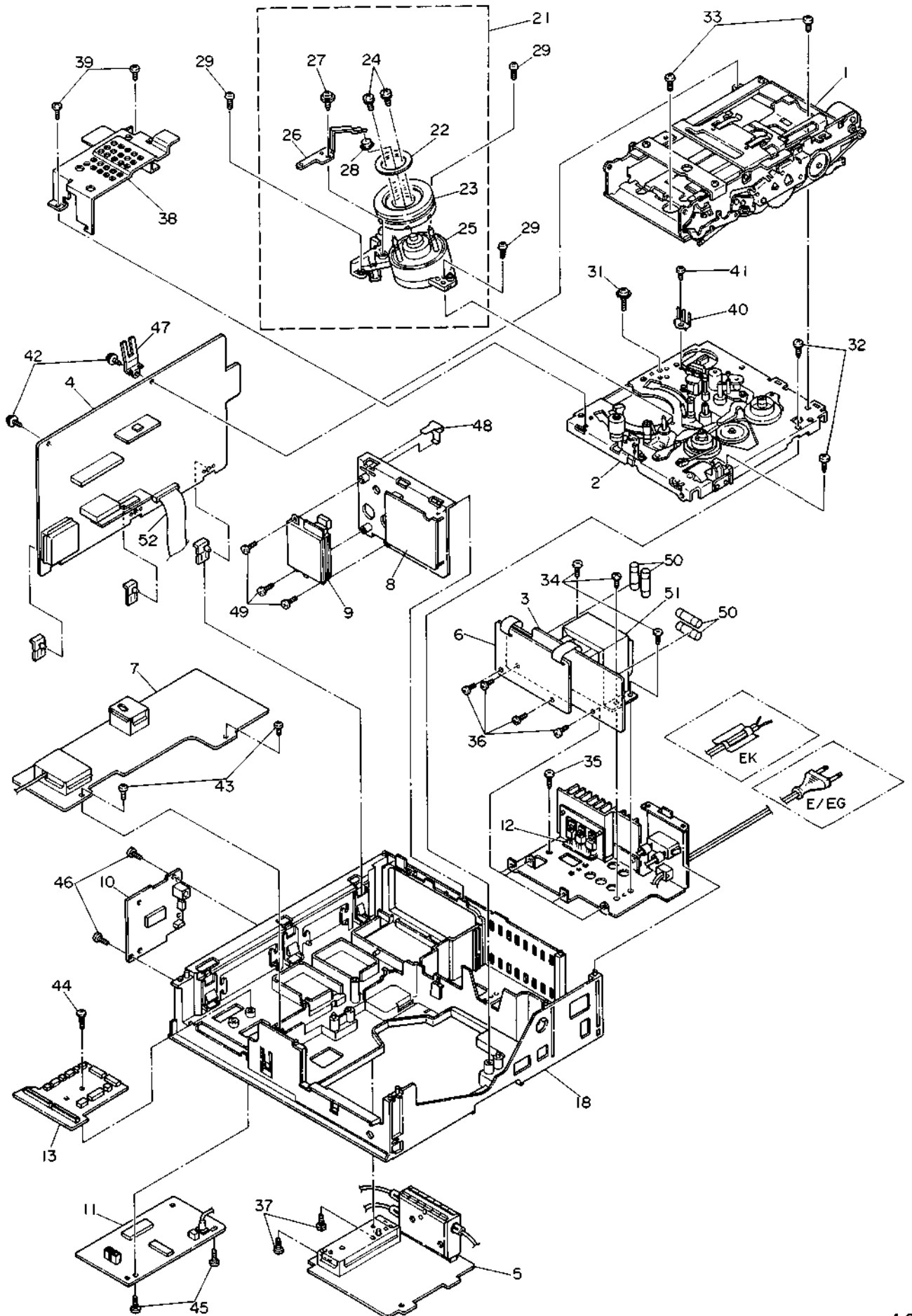
4.1 PACKING ASSEMBLY [M1]



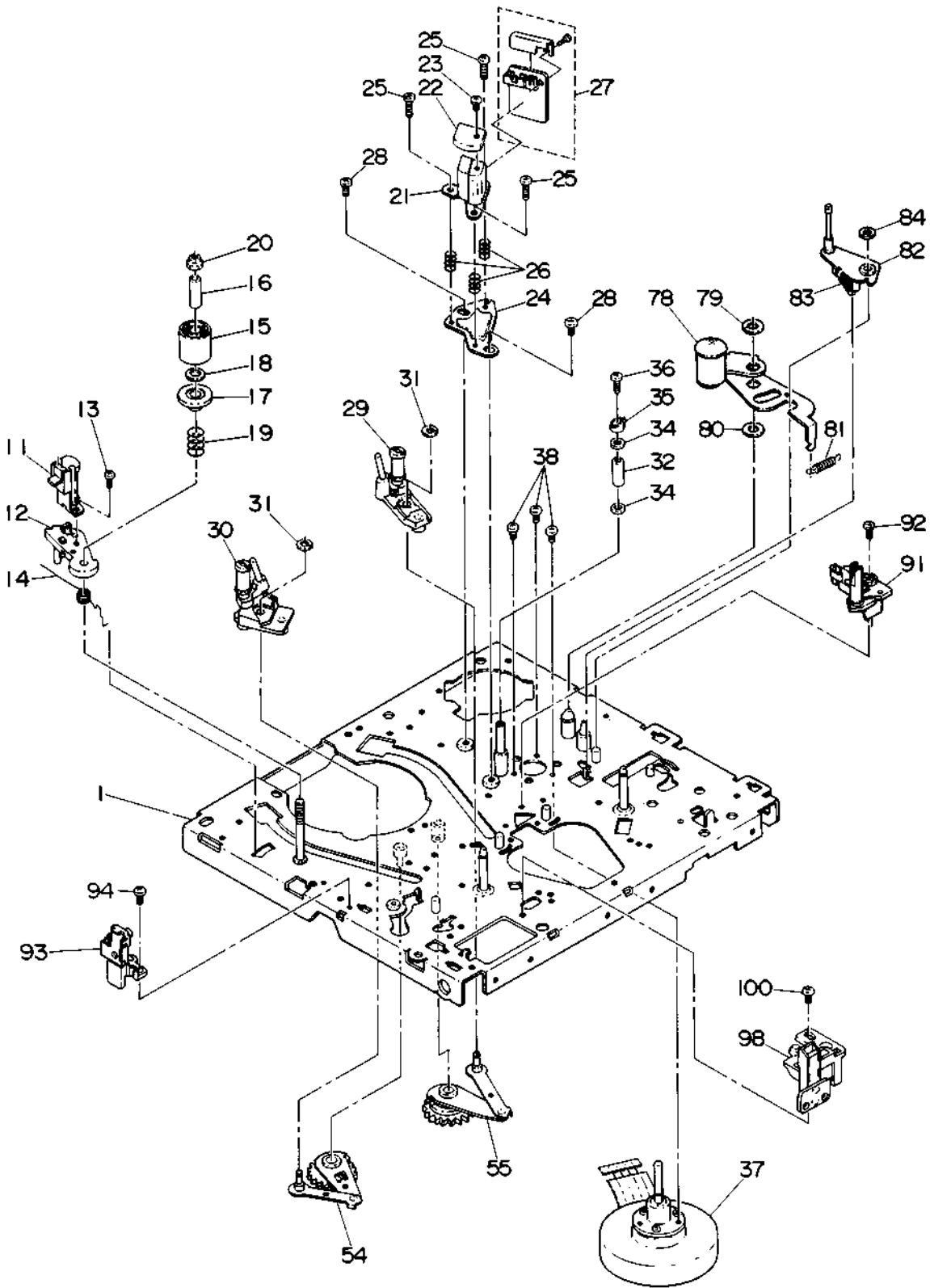
4.2 CABINET ASSEMBLY [M2]



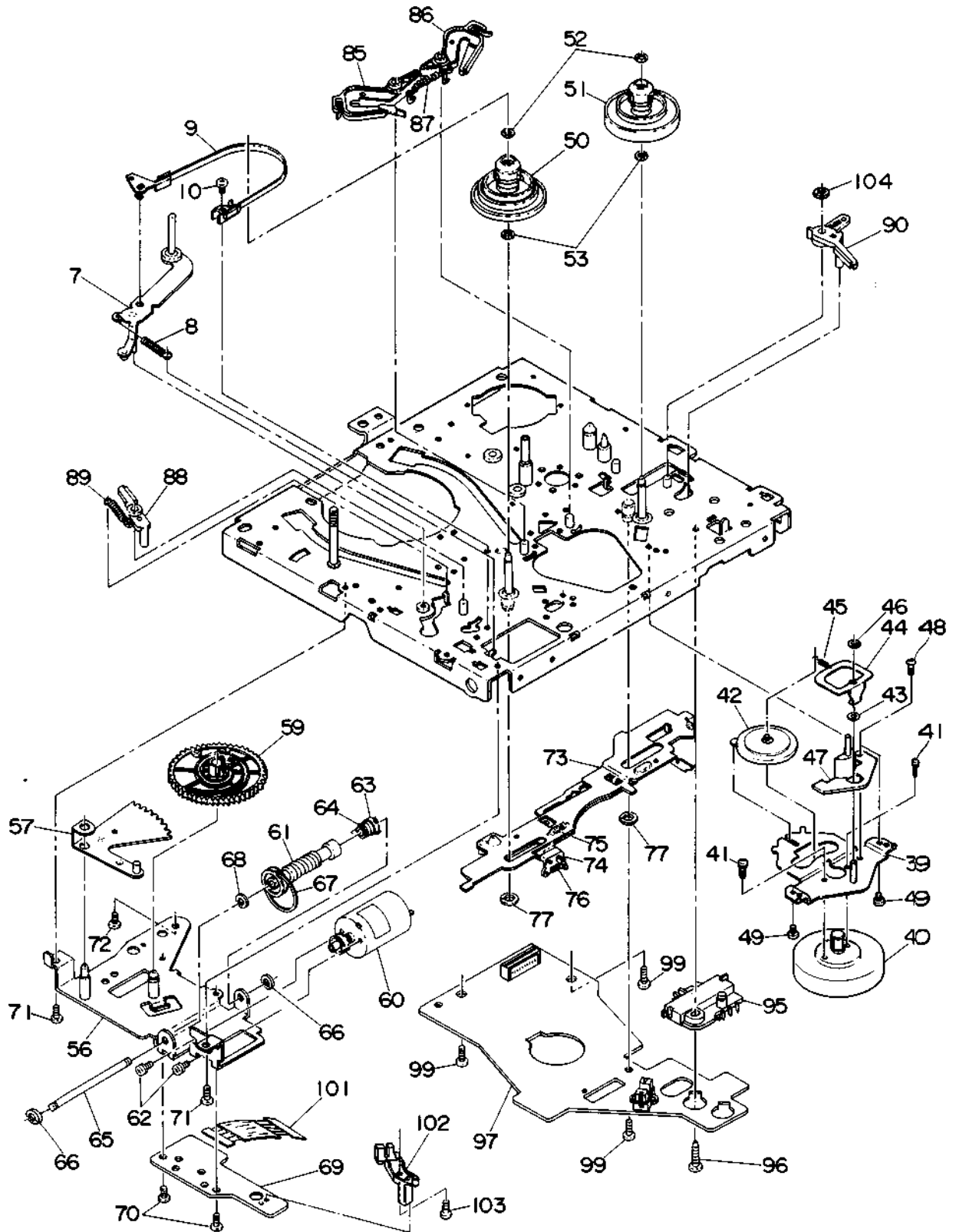
4.3 CHASSIS ASSEMBLY [M3]



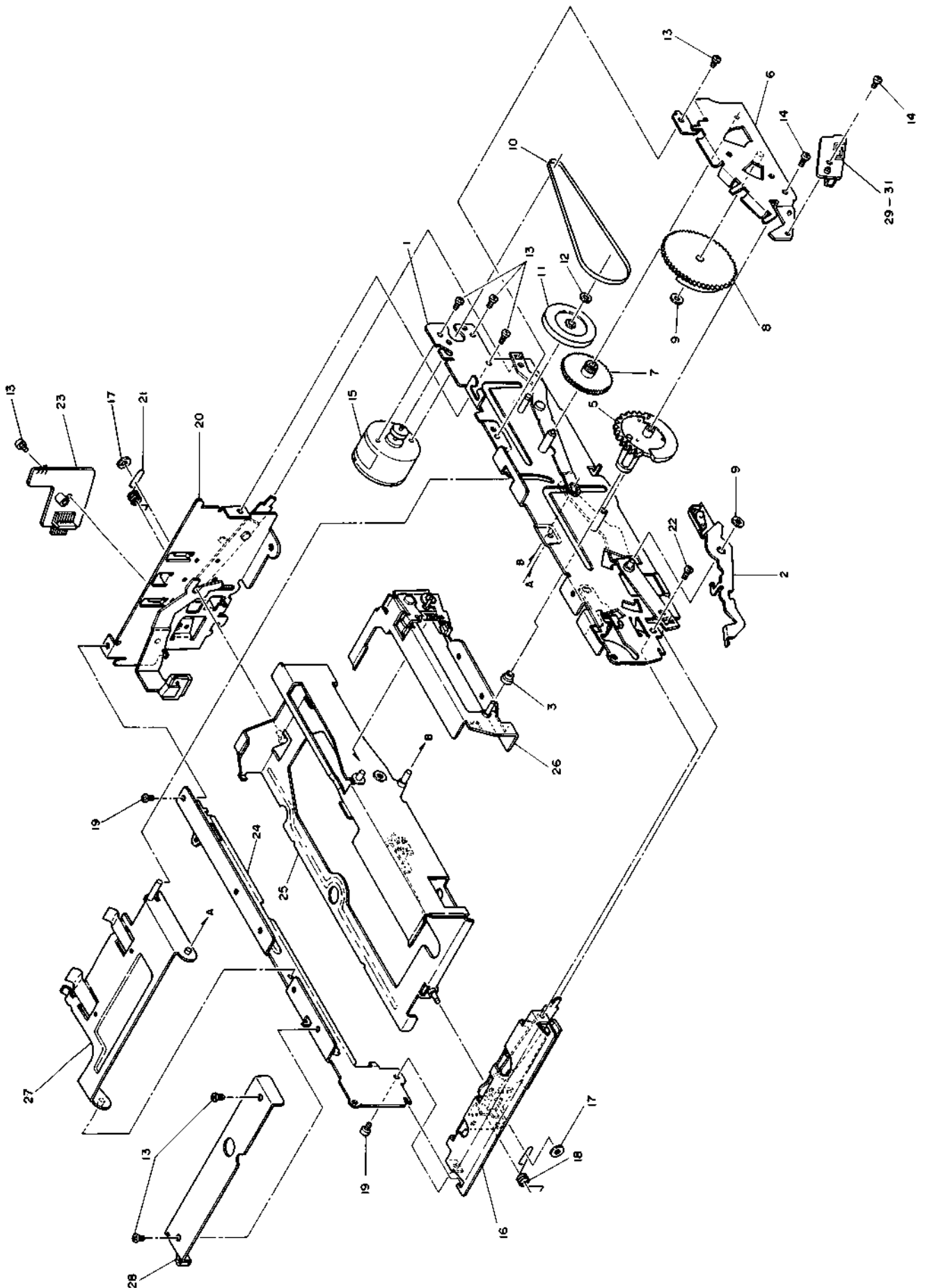
4.4 MECHANISM ASSEMBLY [M4]-1



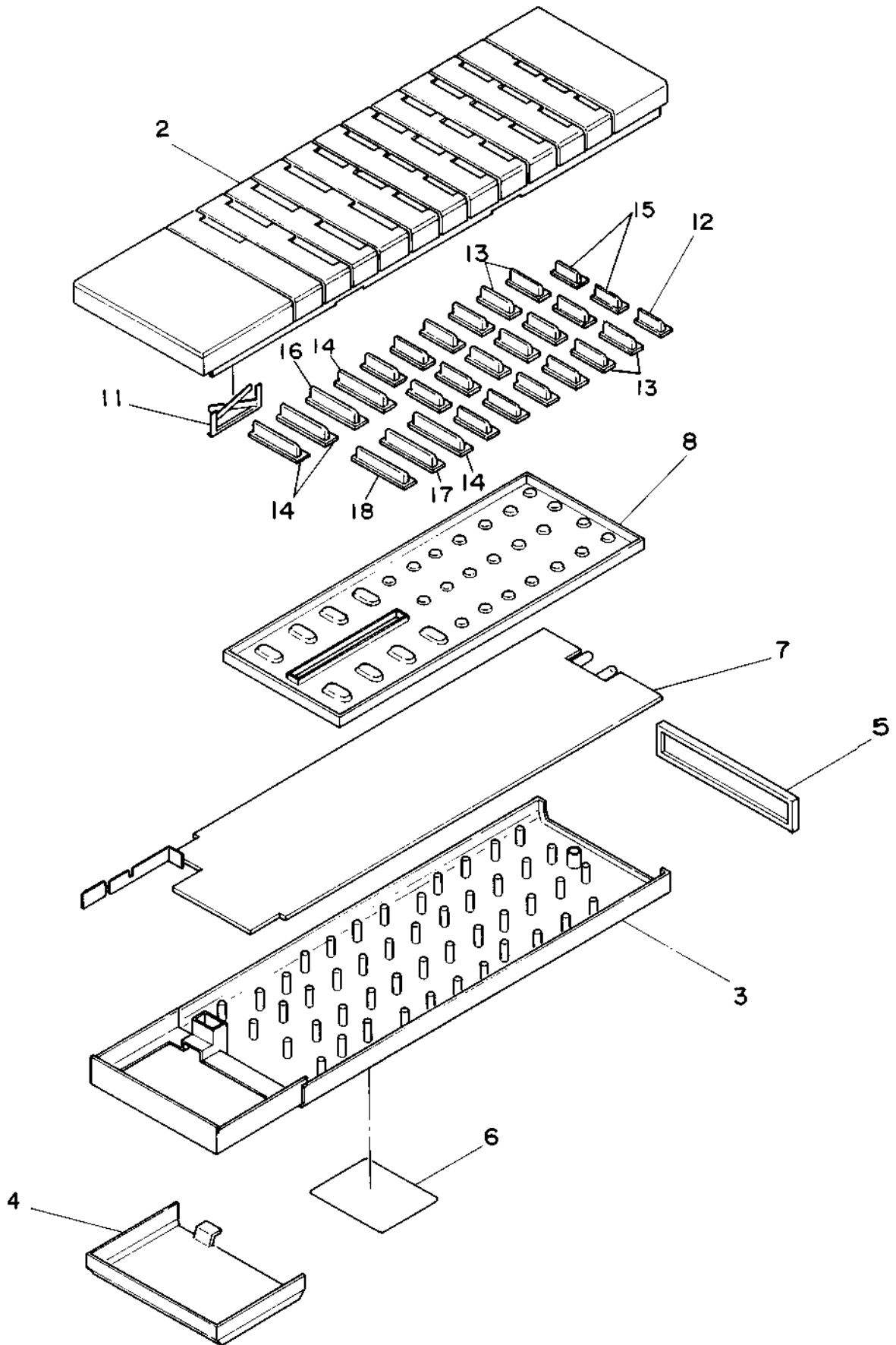
MECHANISM ASSEMBLY [M4]-2



4.5 CASSETTE HOUSING ASSEMBLY [M5]



4.6 REMOTE CONTROL UNIT [M6]



SECTION 5 PARTS LIST

SAFETY PRECAUTION

Parts identified by the \triangle symbol are critical for safety. Replace only with specified part numbers.

ABBREVIATIONS IN THIS LIST ARE AS FOLLOWS:

RESISTORS— All resistance values are in ohms (Ω), unless otherwise indicated.

k	: 1,000 (Kilo)
M	: 1,000,000 (Mega)
Chip R	: Chip Resistor
Chip VR	: Chip Variable Resistor
Comp. R	: Composition Resistor
CR	: Carbon Film Resistor
FR	: Fusible Resistor
MFR	: Metal Film Resistor
MPR	: Metal Plate Resistor
OMR	: Oxide Metal Film Resistor
PMR	: Precision Metal Film Resistor
UFR	: Unflammable Resistor
VR	: Variable Resistor (Potentiometer)
WR	: Wire Wound Resistor

CAPACITORS— All capacitance values are in μF , unless otherwise indicated.

pF	: $\mu\mu\text{F}$ (Pico farad)
C Cap	: Ceramic Capacitor
Chip Cap	: Chip Capacitor
Chip T Cap	: Chip Tantalum Capacitor
E Cap	: Electrolytic Capacitor
FM Cap	: Film Mica Capacitor
LL Cap	: Low Leak Current Electrolytic Capacitor
MM Cap	: Metalized Mylar Capacitor
MP Cap	: Metalized Paper Capacitor
MY Cap	: Mylar Capacitor
NP Cap	: Non-polar Capacitor
PC Cap	: Polycarbonate Capacitor
PP Cap	: Polypropylene Capacitor
PS Cap	: Polystyrol Capacitor
T Cap	: Tantalum Capacitor
TF Cap	: Thin Film Capacitor
TR Cap	: Trimmer Capacitor

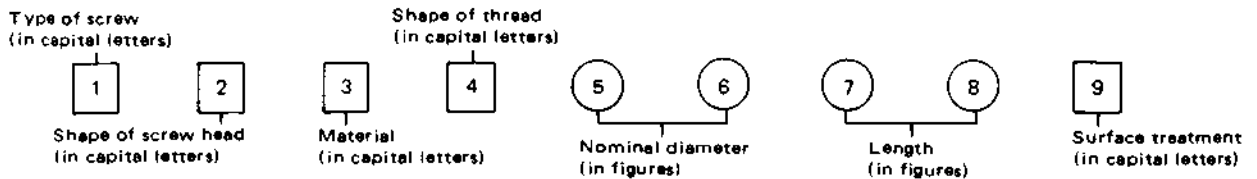
NOTES:

- [M] indicates mechanical symbol number.
- [2 digits] indicates circuit board symbol number.
- "X " indicates quantity per set.

5.1 STANDARD PART NUMBER CODING

5.1.1 Screw coding

Standard screw part numbers are as follows.

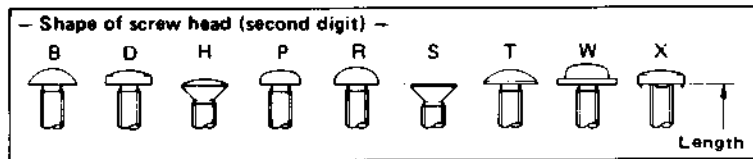
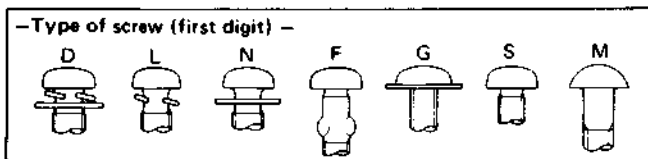


Type of screw (first digit)

- S Normal screws
- D Assembled machine screws (with plain and spring washers)
- L " (with spring washer)
- N " (with plain washer)
- F Feather screws
- G Washer head tapping screws
- M Wood screws

Shape of screw head (second digit)

- B Brazier head
- D Binding head
- H Oval countersunk head
- P Pan head
- R Round head
- S Flat head
- T Truss head
- W Washer head (machine screws)
- X Toothed head

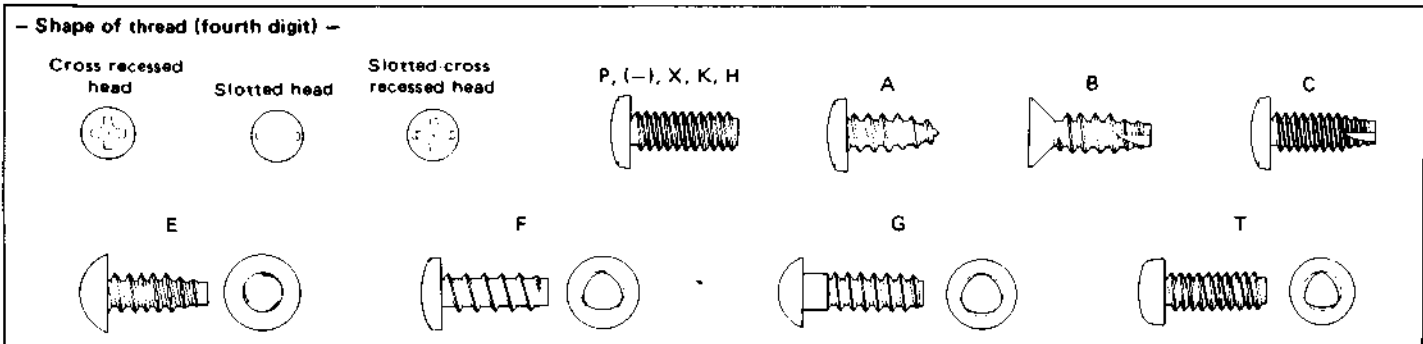


Material (third digit)

- S Steel
- E Stainless steel
- C Cast iron
- U Copper
- B Brass
- P Phosphor bronze
- N Nickel silver
- Y Cast brass
- A Aluminum
- Z Zinc alloy
- K Polycarbonate

Shape of thread (fourth digit)

- P Cross recessed head screws
- (-) Slotted head machine screws
- X Slotted-cross recessed head machine screws
- K Cross recessed head machine screws for precision equipment (type 1)
- H " (type 3)
- A Cross recessed head tapping screws (type 1)
- B " (type 2)
- C " (type 3)
- E Cross recessed head special tapping screws (brand : evertight)
- F " (brand : P-tight)
- T " (brand : taptight)
- G " (brand : taptight)



Nominal diameter (fifth and sixth digits)

The fifth and sixth digits indicate a nominal diameter or dimension. If the dimension exceeds 10 mm, three digits are used. The number indicates a nominal diameter or dimension, given in millimeters, multiplied by ten.

Surface treatment (ninth digit)

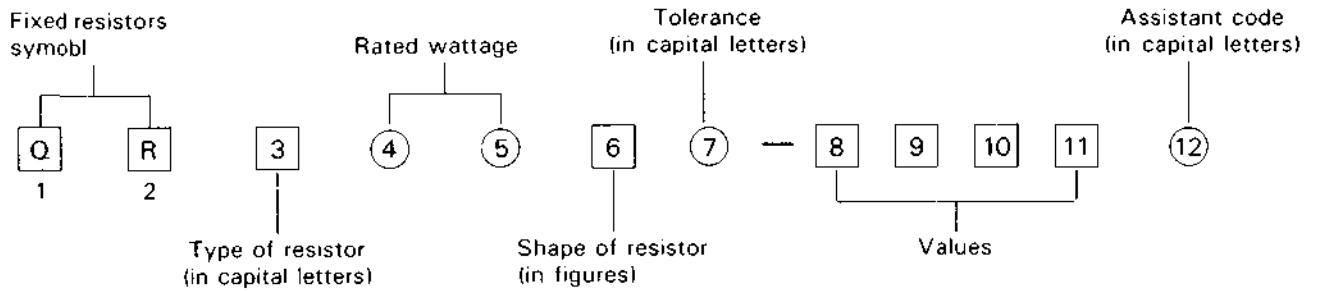
- Z Dichromate treatment after galvanizing (MFZn II-C)
- N Nickel plating (MFNi II, MFNi I)
- R Chromium plating (MBCr II, MBCr I)
- G Silver plating (SP4)
- B Black coating after plating
- F Blackening of iron (FB)
- M Blackening after galvanizing
- K Pickling of brass (PF2)
- P Phosphate treatment
- W Uni-chrome plating
- L Coated with transparent paint
- A Colored red after galvanizing (MFZn II-C)
- C Colored blue after galvanizing (MFZn II-C)
- T Colored green after galvanizing (MFZn II-C)
- V Colored purple after galvanizing (MFZn II-C)

Length (seventh and eighth digits)

The seventh and eighth digits indicate length in millimeters. The preceding figure is zero when the dimension is smaller than 10 mm. For machine screws used in precision equipment whose length is given in units of 0.1 mm, the number indicates ten times the size of their length.

5.1.2 Fixed resistor coding

Fixed resistor part numbers are as follows.



Type of resistor (third digit)	Rated wattage (fourth and fifth digits)	Tolerance (seventh digit)	Assistant code (twelfth digit)
C Composition resistors	A0 1/10 W	F ± 1 %	A Small type
D Carbon film resistors	18 1/8 W	G ± 2 %	B Small type
F Unflammable resistors	16 1/6 W	J ± 5 %	S Small type
G Oxide metal film resistors	14 1/4 W	K ± 10 %	Y Lead taping
H Fusible resistors	01 1 W	M ± 20 %	Z Lead taping
M Metal plate resistors	02 2 W		
S Metal glazed resistors	03 3 W		
V Precision metal film resistors	04 4 W		
W Wire wound resistors	05 5 W		
X Metal film resistors	06 6 W		
Z Special resistors	07 7 W		
	75 7.5 W		
	08 8 W		
	10 10 W		
	15 15 W		
	A6 16 W		
	20 20 W		
	30 30 W		

Values (eighth – tenth or eleventh digits)	examples:
R47	0.47 Ω
4R7	4.7 Ω
470	47 × 10 ⁰ Ω = 47 Ω
471	47 × 10 ¹ Ω = 470 Ω
472	47 × 10 ² Ω = 4.7 kΩ
473	47 × 10 ³ Ω = 47 kΩ
474	47 × 10 ⁴ Ω = 470 kΩ
475	47 × 10 ⁵ Ω = 4.7 MΩ

QRV resistance shown by four digits:

4640	464 × 10 ⁰ Ω = 464 Ω
4641	464 × 10 ¹ Ω = 4.64 kΩ
4642	464 × 10 ² Ω = 46.4 kΩ

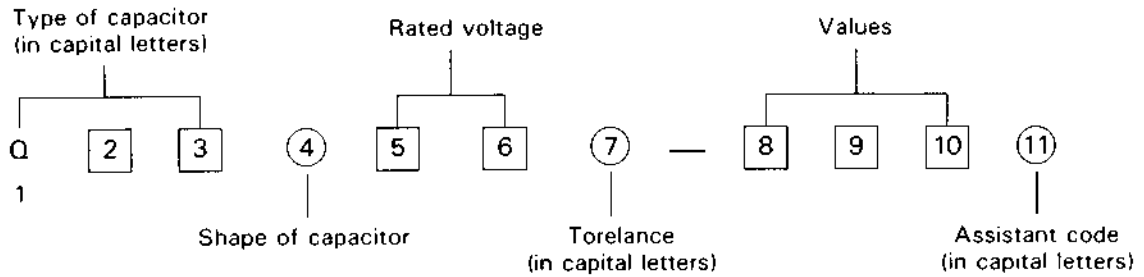
Shape of resistor (sixth digit)

Note: indicates flame retardant resistor.

Type of resistor \ Shape of resistor	C	D	F	G	H	M	S	V	W	X
1										
2										
3										
4										
5									(L) type	
6										
7			Lug (B) type							
8			Lug (A) type							
9			Lug (C) type							

5.1.3 Fixed capacitor coding

Fixed capacitor part numbers are as follows.



Ceramic capacitors

Type of capacitor (first – third digits)		Shape of capacitor (fourth digit)				
		Mono-direction	Kink lead	Axial lead	Axial forming lead	Chip
Symbol	Characteristics					
QCC	Ceramic	1		4	5	
QCD	High capacitance					A
QCF	High capacitance	1,4	3			8,A
QCS	Temperature compensation	1	3	4	5	8,A
QCT	Temperature compensation	Special coding				8,A
QCV	Ceramic			1	3	
QCX	Ceramic			1	3	
QCY	High capacitance	1,4	3	6	7	8,A
QCZ	Special type	Special coding				
QCB	Ceramic			B	C	

Electrolytic capacitors

Type of capacitor (first-third digits)		Shape of capacitor (fourth digit)				
		Tubular	Mono-direction	Anti-stress	Forming	Snap-in
Symbol	Characteristics					
QEB	Low leakage		4	5	6	
QEC	Low leakage		4,8,A	9,B	6,C	
QEE	Tantalum (normal)		4	5	6	
	Tantalum (small)		8			
QEF	Chip tantalum	8 (chip type)				
QEG	Low impedance		4			
QEK	Miniature type		4	5	6	
QEL	Small type		4	5	6	7
QEM	Small type		4,A	5	6	
QEN	Non-polar	2	4	5	6	
QEP	Non-polar (small)		4,A	5,B	6,C	
QER	Miniature type		4	5	6	
QET	Small type	2	4,A	5,B	6,C	7
QEU	Small type		4	5	6	
QEV	Small type		4		6	7
QEW	Normal	2	4	5	6	7

Paper film capacitors

Type of capacitor (first – third digits)		Shape of capacitor (fourth digit)				
Symbol	Characteristics	Tubular	Normal		Flame retardant	
			Mono-direction	Kink lead	Mono-direction	Kink lead
QFA	Metalized polypropylene				7	
QFE	Metalized mylar				5	
QFF	Film mica		4			
QFG	Polypropylene film		4	8		
QFH	Metalized mylar	2	4	3	5,7	6
QFJ	Mylar (special)		4			
QFK	Metalized mylar (small)				5	
QFM	Mylar	2	4	3,7	5	6
QFN	Mylar (small)		4	3		
QFP	Polypropylene		4	3,8		
QFS	Polystyrole	2	4	3		
QFV	Thin film		4	8		
QFZ	Special type	Special coding				

Rated voltage (fifth and sixth digits)

Sixth digit Fifth digit	A	B	C	D	E	F	G	H	J	K	V	W	X
	0						3.15	4.0		6.3			
1	10		16	20	25		40	50	63	80	35		
2	100	125	160	200	250	315	400	500	630		350	450	600
3	1000	1250		2000				5000					

Tolerance (seventh digit)

A	+100 -10 %	M	±20 %
F	±1 %	N	±30 %
G	±2 %	P	+100 -0 %
H	+50 -10 %	R	+30 -10 %
J	±5 %	X	+40 -20 %
K	±10 %	Z	+80 -20 %

Values (eighth – tenth digits)

Example : Values are in picofarads

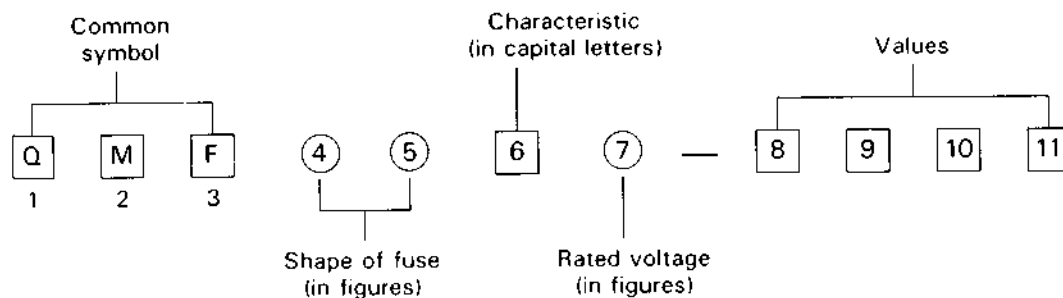
101	10×10^1 pF	100 pF
102	10×10^2 pF	1,000 pF (0.001 μ F)
103	10×10^3 pF	10,000 pF (0.01 μ F)
104	10×10^4 pF	100,000 pF (0.1 μ F)
105	10×10^5 pF	1 μ F
5R0	5.0 pF

Assistant code (eleventh digit)

- G Small size
- Z Lead tapping
- Y Lead tapping

5.1.4 Fuse coding

Standard fuse part numbers are as follows.



Shape of fuse

(fourth and fifth digits)

51	φ5.2 × 20 mm
60	φ6.4 × 30 mm
61	φ6.35 × 31.8 mm
63	φ6.4 × 30 mm with lead wires
66	φ6.35 × 31.8 mm with lead wires
00	Special type

Rated voltage

(seventh digit)

1	AC125 V
2	AC250 V
3	0.1 – 1 A : AC250 V 1.25 – 6.3 A : AC125 V

Values

(eighth-tenth or eleventh digits)

example:

R63	0.63 A
1R0	1.0 A
2R5	2.5 A
100	10 A
R315	0.315 A
1R25	1.25 A

Characteristics (sixth digit)

Symbol	Fusing Current	Fusing Time	Remarks
A	210 %	Within 2 min.	Anti-rush type (for Europe)
	275 %	0.6 – 10 sec.	
	400 %	0.15 – 3 sec.	
	1000 %	0.02 – 0.3 sec.	
B	210 %	Within 30 min.	Regular fusible type (for SEMKO, Europe)
	275 %	0.05 – 2 sec.	
	400 %	0.01 – 0.3 sec.	
C	135 %	Within 1 hr.	Regular fusible type (for UL, Japan)
	200 %	Within 2 min.	
E	210 %	Within 2 min.	Anti-rush type (for Europe)
	275 %	0.6 – 10 sec.	
	400 %	0.15 – 3 sec.	
	1000 %	0.02 – 0.3 sec.	
J	135 %	Within 1 hr.	Anti-rush type
	200 %	Within 2 min.	
M	135 %	Within 1 hr.	Regular fusible type (for UL)
	200 %	Within 2 min.	
R	160 %	Within 1 hr.	Regular fusible type
	200 %	Within 2 min.	
S	160 %	Within 1 hr.	Anti-rush type
	200 %	Within 2 min.	
	700 % – 2000 %	Within 0.01 sec.	
U	135 %	Within 1 hr.	Anti-rush type (for UL)
	200 %	Within 2 min.	
	800 % – 2000 %	Within 0.01 sec.	

#	REF. NO.	PART NO.	PART NAME, DESCRIPTION

PACKING AND ACCESSORIES [M1]			
1		PQ31396-5-2	PACKING CASE, E
		PQ31396-5-2	PACKING CASE, EG
		PQ31396-4-3	PACKING CASE, EK
2		PQ31397A-1	CUSHION ASS'Y
3		PQ41026-11	PROTECT SHEET
4		PQM30021-65	POLY BAG, E/EG, FOR SET
		PQM30045-28	POLY BAG, EK, FOR SET
5		-	CABINET ASS'Y, REFER TO [M2]
6		PUP40329	SERIAL NO. STICKER, X2
7		-	-
8		-	-
9		-	-
10		-	-
△	11	PU59167-3	CABLE ASS'Y
△	OR	PU59168-3	CABLE ASS'Y
	12	PU56142	PIN CORD ASS'Y
	13	QPGA020-02003	POLY BAG, E/EG
		PQM30023-8	POLY BAG, EK
△	14	PU30425-878	INSTRUCTION BOOK, E
△		PU30425-870	INSTRUCTION BOOK, EG
△		PU30425-863	INSTRUCTION BOOK, EK
	15	BT-20069A	WARRANTY CARD, EG
		BT-20060	GUARANTY CARD, EK
△	16	PU36158-1-1	DBP INF. SHEET, EG ONLY
	17	BT-20066	E. DISTRI. LIST, EK ONLY
	18	QPGA025-03505	POLY BAG, E/EG
		PQM30023-5	POLY BAG, EK
△	19	PQ10342Q-5	REMOTE CONTROL UNIT, E, REFER TO [M6], INCL. 20
△		PQ10342J-5	REMOTE CONTROL UNIT, EG, REFER TO [M6], INCL. 20
△		PQ10342P-5	REMOTE CONTROL UNIT, EK, REFER TO [M6], INCL. 20
	20	PQ10342-009	POLY BAG, REMOTE CONTROL UNIT
	21	-	CASSETTE TAPE, PTE-30-101
	22	UM-4NJ2P	BATTERY, 2 CELLS

CABINET ASSEMBLY [M2]

△	1	PQ10399C	FRONT PANEL ASS'Y, E, INCL. 31-40
△		PQ10399B-5	FRONT PANEL ASS'Y, EG, INCL. 31-40
△		PQ10399A	FRONT PANEL ASS'Y, EK, INCL. 31-40
△	2	PQ10365-4	TOP COVER
	3	-	-
	4	SDSF3010Z	TAP. SCREW, X3, BOTTOM PLATE
	5	PU57662-1-1	FOOT, X4
△	6	PQ10362-1-4	BOTTOM PLATE
	7	SDSA4014M	TAP. SCREW, X4, TOP COVER
	8	-	RATING LABEL
	9	PQ31189F	CASSETTE PLATE ASS'Y
	10	PQ42946	DOOR SPRING
	11	PQ42269-1-4	ROUND KNOB, LEVEL
	12	-	CHASSIS ASS'Y, REFER TO [M3]
	13	-	FRONT BOARD ASS'Y, REFER TO [21]
	14	-	HEADPHONE BOARD ASS'Y, REFER TO [25]

#	REF. NO.	PART NO.	PART NAME, DESCRIPTION
15		SDSF2608Z	TAP. SCREW, X7, FRONT AND HEADPHONE BOARDS
16		PQM30017-24	SLIT WASHER, FRONT BOARD
17		PQ31497B	DOOR ASS'Y, E/EG
		PQ31497A	DOOR ASS'Y, EK
18		PQ31546C	MEMBRANE ASS'Y, E
		PQ31546B-1	MEMBRANE ASS'Y, EG
		PQ31546A	MEMBRANE ASS'Y, EK
△	19	PQ31498-3	POWER PLATE, E
△		PQ31498-2	POWER PLATE, EG
△	20	PQ41700	LABEL, EK ONLY
△	21	PU58020-3	CAUTION LABEL, X2, EK ONLY
	22	PQ42517-2	VOLUME KNOB, X2, PICTURE, TRACKING
	23	-	-
	24	-	-
	25	-	-
	26	-	-
	27	-	-
	28	-	-
	29	-	-
	30	-	-
	31	PQ42658	POWER BUTTON, E/EK, OPERATE
		PQ42658-2	POWER BUTTON, EG, OPERATE
	32	PQ42659	TACT BUTTON, X2, COUNTER/REMAIN/ DATE, RESET
	33	PQ31494	OPERATION KNOB (A), E/EK
		PQ31494-2-2	OPERATION KNOB (A), EG
	34	PQ31493	OPERATION KNOB (B), E/EK
		PQ31493-2	OPERATION KNOB (B), EG
	35	PQ42660	OTR BUTTON, INSTANT REC
	36	PQ31489	SLIDE KNOB (L)
	37	PQ31490	SLIDE KNOB (R)
	38	PQ31492	SLIDE GUIDE, X2
	39	PQ31491	SLIDE PLATE
	40	SDSF2608Z	TAP. SCREW, X2, SLIDE PLATE

CHASSIS ASSEMBLY [M3]

1	PUS28104A	CASSETTE HOUSING ASS'Y, REFER TO [M5]
2	-	MECHANISM ASS'Y, REFER TO [M4]
3	-	POWER TRANS. BOARD ASS'Y, REFER TO [01]
4	-	V/M/S BOARD ASS'Y, REFER TO [03]
5	-	TUNER/IF BOARD ASS'Y, REFER TO [07]
6	-	REGULATOR BOARD ASS'Y, REFER TO [02]
7	-	AUDIO BOARD ASS'Y, REFER TO [09]
8	-	TERMINAL BOARD ASS'Y, REFER TO [06]
9	-	RF CONV. & MIX BOOSTER, REFER TO [07]
10	-	VPS BOARD ASS'Y, E/EG, REFER TO [18]
11	-	DEMODULATOR BOARD ASS'Y, E/EG, REFER TO [14]
12	-	POWER TRANSISTOR BOARD ASS'Y, REFER TO [19]
13	-	JUNCTION BOARD ASS'Y, REFER TO [16]

#	REF. NO.	PART NO.	PART NAME, DESCRIPTION
	14	-	-
	15	-	-
	16	-	-
	17	-	-
	18	-	CHASSIS
	19	-	-
	20	-	-
	21	PDV2063A	DRUM ASS'Y, INCL. 22-28
	22	-	UPPER DRUM BOARD, REFER TO [41]
	23	PDM2007A	UPPER DRUM ASS'Y
	24	PDM4001A	DRUM SCREW ASS'Y, X2
	25	PDM2035F-2	LOWER DRUM MOTOR ASS'Y
	26	PDM4015A-4	BRUSH ASS'Y
	27	DPSP2606Z	ASS'Y SCREW
	28	PQ41696B	COMMUTATOR ASS'Y
	29	SDSP2608Z	SCREW, X3, DRUM ASS'Y
	30	-	-
	31	PQ41396	SPECIAL SCREW, MAIN DECK
	32	SDSA4014Z	TAP. SCREW, X2, MAIN DECK
	33	SDST2606Z	TAP. SCREW, X2, CASS. HOUSING
△	34	SDSA4012Z	TAP. SCREW, X3, POWER TRANS.
△	35	SDST3014C	TAP. SCREW, TRANS BRACKET
△	36	SDST3006Z	TAP. SCREW, X4
	37	SDSF3010Z	TAP. SCREW, X2, TUNER/IF BOARD
	38	PQ31665A	DRUM SHIELD ASS'Y
	39	SDST2605Z	TAP. SCREW, X2, DRUM SHIELD ASS'Y
	40	PQ40433-2	EARTH LUG
	41	SDST2606Z	TAP. SCREW, EARTH LUG
	42	DPSP2606Z	SCREW, X2, V/M/S BOARD
	43	SDSF3010Z	TAP. SCREW, X2, AUDIO BOARD
	44	SDSF3010Z	TAP. SCREW, JUNCTION BOARD
	45	SDSF3010Z	TAP. SCREW, E/EG, X2, DEMOD BOARD
	46	SDSF3010Z	TAP. SCREW, E/EG, X2, VPS BOARD
	47	PQ42271	EARTH SPRING, CASS. HOUSING
	48	PQ42600	EARTH PLATE, RF CONV. & MIX BOOSTER
	49	SDSF3010Z	TAP. SCREW, X3, RF CONV. & MIX BOOSTER
	50	-	FUSE, F1-4, E/EG, REFER TO [01]
		-	FUSE, F1-3, EK, REFER TO [01]
△	51	PU59459	POWER TRANSFORMER, E/EG
△		PU59458	POWER TRANSFORMER, EK
	52	PU58865-3	FLAT WIRE
.....			
MECHANISM ASSEMBLY [M4]			
	1	-	MAIN DECK ASS'Y
	2	-	-
	3	-	-
	4	-	-
	5	-	-
	6	-	-
	7	PQ41944A-7	TENSION ARM ASS'Y INCL. 8
	8	PQ41952-3	SPRING
	9	PQ41948A	TENSION BAND ASS'Y
	10	SDST2606N	TAP. SCREW, TENSION BAND ASS'Y
	11	PU57641-2	FULL ERASE HEAD

#	REF. NO.	PART NO.	PART NAME, DESCRIPTION
	12	PQ31036	FE HEAD BASE
	13	SPSG2606Z	TAP. SCREW, FE HEAD
	14	PQ41954-1-1	TORSION SPRING
	15	PQ41955	IMPEDANCE ROLLER
	16	PQ41956	COLLAR
	17	PQ41957	LOWER FLANGE
	OR	PQ42958	LOWER FLANGE
	18	PQM30018-39	SPACER
	OR	PQM30018-50	SPACER
	19	PQM30002-124	COMP. SPRING
	20	PQ40353	NYLON NUT
	21	PU59253	A/CTL HEAD
	22	PU56535	SHIELD CAP
	23	HPSP2015N	SCREW, SHIELD CAP
	24	PQ42208	HEAD BASE
	25	SPSP2608Z	SCREW, X 3, A/CTL HEAD
	26	PU30080-49	SPRING, X 3
	27	-	A/CTL HEAD BOARD, REFER TO [12]
	28	SDSP2606Z	SCREW, X2, HEAD BASE
	29	PQ41963A-1	P. BASE ASS'Y (I)
	30	PQ41969A	P. BASE ASS'Y (S)
	31	PQM30017-5	SLIT WASHER, X 2
	32	PU53629-2	TAPE GUIDE
	33	-	-
	34	PQ40268-2	GUIDE FLANGE, X 2
	35	PQ41346	GUIDE POLE CAP
	36	SDSP2006Z	SCREW, TAPE GUIDE
△	37	PU58635V	CAPSTAN MOTOR
	38	SPSP2605N	SCREW, X3, CAPSTAN MOTOR
△	39	PQ41974A	R M BRACKET ASS'Y
△	40	PU58636W	REEL MOTOR
	41	LPSP2604Z	SCREW, X2, REEL MOTOR
	42	PU58645-1-1	IDLER ARM
	43	Q03093-834	WASHER
	44	PQ41976A-1	SPRING ARM ASS'Y, INCL. 45
	45	PQ42212-1-4	TENSION SPRING
	46	PQM30017-22	SLIT WASHER
	47	PQ41978	HOLDER
	48	SPST2606Z	TAP. SCREW
	49	SPST2606Z	TAP. SCREW, X 2
	50	PU59250-1-1	REEL DISK (S)
	51	PU58638-1-2	REEL DISK (T)
	52	PQM30017-5	SLIT WASHER, X 2
	53	Q03093-828	WASHER, X 2
	54	PQ41979A-4	L ARM ASS'Y (S)
	55	PQ41985A-2	L ARM ASS'Y (T)
	56	PQ41992A-1	CAM BRACKET ASS'Y
	57	PQ41994A-1	ARM GEAR ASS'Y
	58	-	-
	59	PQ20250-1-1	CONTROL CAM
△	60	PQ41996A	MODE MOTOR ASS'Y
	61	PQ41998A	WORM ASS'Y
	62	LPSP2604Z	SCREW, X2, MODE MOTOR
	63	PQ42001	WINDMILL
	64	PQ42002	CLUTCH SPRING
	65	PQ42003	WORM SHAFT
	66	PQM30017-5	SLIP WASHER, X 2
	67	PQM30003-17	BELT
	68	PQM30018-22	SPACER
	69	-	RELAY BOARD, REFER TO [52]

#	REF. NO.	PART NO.	PART NAME, DESCRIPTION
70		SPST2606Z	TAP. SCREW, X 2, RELAY BOARD
71		SPST2606Z	TAP. SCREW, X 2, CAM BRACKET ASS'Y
72		SPSP2603Z	SCREW, CAM BRACKET ASS'Y
73		PQ42038A-3	PLATE ASS'Y INCL. 74-76
74		PQ31044-1-2	LOCK LEVER
75		PQM30001-191	TENSION SPRING
76		PQM30001-211	TENSION SPRING
77		PQM30017-28	SLIT WASHER, X 2
78		PQ42006B	P R ARM ASS'Y
79		PQM30017-28	SLIT WASHER
80		Q03093-833	WASHER
81		PQM30001-193	TENSION SPRING
82		PQ42013B-4	GUIDE ARM ASS'Y INCL. 83
83		PQ42029	SPRING
84		PQM30017-6	SLIT WASHER
85		PQ42019A-3	M. BRAKE ASS'Y (S)
86		PQ42020A-2	M. BRAKE ASS'Y (T)
87		PQM30001-216	CLUTCH SPRING
88		PQ42021A-1	SUB BRAKE ASS'Y (S) INCL. 89
89		PQ42023-1-2	TENSION SPRING
90		PQ42037A-2	SUB BRAKE ASS'Y (T)
91		PU59452	LED HOLDER
OR		PU58640	LED HOLDER
92		SPST2606Z	TAP. SCREW, LED HOLDER
93		-	END SENSOR BOARD ASS'Y, REFER TO [54]
94		SPST2606Z	TAP. SCREW, END SENSOR BOARD
95		PU58642	SLIDE ENCODER
96		SDSP2610Z	SCREW, SLIDE ENCODER
97		-	DECK TERMINAL BOARD ASS'Y, REFER TO [51]
98		-	REC SAFETY BOARD ASS'Y, REFER TO [53]
99		SDSP2606Z	SCREW, X 3, DECK TERMINAL BOARD
100		SDST2606Z	TAP. SCREW, REC SAFETY BOARD
101		PW30110-26DD885	PARALLEL WIRE
102		PU59251	REEL SENSOR (S)
103		SPSP2603Z	SCREW, REEL SENSOR (S)
104		PQM30017-6	SLIT WASHER
.....			
CASSETTE HOUSING ASSEMBLY (M5)			
1		PQ31008A	MAIN BRACKET ASS'Y
2		PQ41921A-2	DOOR LEVER ASS'Y
3		PQ42214-3	COLLAR
4		-	-
5		PQ31010	DRIVE GEAR
6		PQ31012A	GEAR BKT ASS'Y
7		PQ41906	SHIFT GEAR
8		PQ31021	CAM GEAR
9		PQM30017-24	SLIT WASHER, X 2
10		PQM30003-16	BELT
11		PQ42055	PULLEY GEAR
12		PQM30017-23	SLIT WASHER
13		SPSP2603Z	SCREW, X 7

#	REF. NO.	PART NO.	PART NAME, DESCRIPTION
14		SPSP2605Z	SCREW, X 2
15		PQ41927A	MOTOR ASS'Y
16		PQ31014A	FRONT BKT ASS'Y
17		PQM30017-5	SLIT WASHER, X 2
18		PQ31016-1-2	TOR. SPRING
19		SPST2605Z	TH. TAP. SCREW, X 2
20		PQ31017A	REAR BKT ASS'Y
21		PQ31016-2-2	TOR. SPRING
22		SPST2605Z	TH. TAP SCREW
23		-	LED BOARD, REFER TO [56], INCL. 29
24		PQ31237A	SIDE BRACKET
25		PQ31022A	HOLDER ASS'Y
26		PQ31024A	SLIDER ASS'Y
27		PQ31026A-2	H. LEVER ASS'Y
28		PQ41903	STAY
29		-	CASSETTE SENSOR BOARD
30		PN268R-NC	PHOTO TRANSISTOR
31		PQ41926	PHOTO TRANSISTOR CAP
.....			
REMOTE CONTROL UNIT (M6)			
1		-	REMOTE CONTROL UNIT, REFER TO [M1], INCL. 2-18
2		PU36137-11	TOP CASE, E
		PU36137-7	TOP CASE, EG
		PU36137-12	TOP CASE, EK
3		PQ31360	BOTTOM CASE
4		PQ31361	BATTERY CAP
5		PU36138-2	WINDOW
6		PU36139-14-2	REMOCON LABEL, E
		PU36139-10-2	REMOCON LABEL, EG
		PU36139-15-2	REMOCON LABEL, EK
7		-	REMOTE CONTROL BOARD ASS'Y, REFER TO [RM]
8		PQ10342-002	RUBBER SHEET
9		-	-
10		-	-
11		PQ10342-005	BATTERY TERMINAL
12		PQ10342-015	BUTTON
13		PQ10342-016	BUTTON, X 18
14		PQ10342-017	BUTTON, X4
15		PQ10342-018	BUTTON, X 2
16		PQ10342-019	BUTTON
17		PQ10342-020	BUTTON
18		PQ10342-021	BUTTON

#	REF. NO.	PART NO.	PART NAME, DESCRIPTION
		PU22415B-04 (E/EG)	POWER SUPPLY BOARD ASS'Y [01],[02]
		PU22415A-04 (EK)	POWER SUPPLY BOARD ASS'Y [01],[02]
△		QMP3980-200	POWER CORD, E/EG
△		QMP5140-200	POWER CORD, EK
△		QHS3771-108	STRAIN RELIEF
		PU22414-2	TRANS. BRACKET, E/EG
		PU22414	TRANS. BRACKET, EK
△		QMC9021-001	AC OUTLET, E/EG
△		PQ31682	AC COVER
△	RY1	PU59457	RELAY, E/EG
	WR1	PW30101-50AA666	PARALLEL WIRE, X 2
△	SCR1	SDST3006Z	TAPPING SCREW, X 3
		PU22415B1-04 (E/EG)	POWER TRANS. BOARD ASS'Y [01]
		PU22415A1-04 (EK)	POWER TRANS. BOARD ASS'Y [01]
	D1	10E2	DIODE
	D2	10E2	DIODE
	D3	10E2	DIODE
	D4	10E2	DIODE
	D5	10E2	DIODE
	D6	10E2	DIODE
	D7	S5688G-TPA3	DIODE
		OR 11E2	DIODE
		OR ERA15-02	DIODE
		OR 1SR35-200AT-82	DIODE
	D8	S5688G-TPA3	DIODE
		OR 11E2	DIODE
		OR ERA15-02	DIODE
		OR 1SR35-200AT-82	DIODE
	D16	S5688G	DIODE, E/EG
		OR 11E2	DIODE, E/EG
		OR ERA15-02	DIODE, E/EG
	DS1	D5FB10-1	DIODE STACK
△	R1	QRZ0052-100	FR
	C1	QFK52AK-473	MY CAP
	C2	QETB1EM-228	E CAP
	C3	QET71EM-478	E CAP
	C4	QETB1CM-338	E CAP
△	C101	QCZ9016-472P	C CAP
△	LF1	PU59581	LINE FILTER, E/EG
△	LF2	PU59586	LINE FILTER, E/EG

#	REF. NO.	PART NO.	PART NAME, DESCRIPTION
△	HD	PU57505	FUSE CLIP, X8, F1-F4, E/EG
△		PU57505	FUSE CLIP, X6, F1-F3, EK
△	TAB	A74316	TAB, X 2
			THE FOLLOWING FUSES ARE NOT INCLUDED IN CIRCUIT BOARD ASS'Y.
△	F1	QMF51E2-R50	FUSE
△	F2	QMF51E2-2R5	FUSE
△	F3	QMF51E2-1R0	FUSE
△	F4	QMF51E2-2R0	FUSE, E/EG
		PU22415B2-04 (E/EG)	REGULATOR BOARD ASS'Y [02]
		PU22415A2-04 (EK)	REGULATOR BOARD ASS'Y [02]
	Q1	-	-
	Q2	-	-
	Q3	2SD637Q,R,S	TRANSISTOR
	Q4	-	-
	Q5	2SD637Q,R,S	TRANSISTOR
	Q6	2SB1185(D,E)	TRANSISTOR
		OR 2SB1015O,Y	TRANSISTOR
	Q7	2SB851R,S	TRANSISTOR
		OR 2SB644R,S	TRANSISTOR
△	Q8	2SA1020O,Y	TRANSISTOR
	D9	S5688G	DIODE
		OR 11E2	DIODE
		OR ERA15-02	DIODE
		OR 1SR35-200AT-82	DIODE
	D10	HZ6C2	ZENER DIODE
	D11	HZ4A2	ZENER DIODE
△	D12	HZ15-2	ZENER DIODE
△	D13	HZ15-2	ZENER DIODE
	D14	HZ12C1	ZENER DIODE
	D15	S5688G	DIODE, E/EG
		OR 11E2	DIODE, E/EG
		OR ERA15-02	DIODE, E/EG
	R1	-	-
	R2	-	-
	R3	QRD181J-682	CR
	R4	QRD181J-122	CR
	R5	QRD181J-272	CR
	R6	QVZ3521-102	VR, UNSW 12 V DC
	R7	QRD181J-332	CR
	R8	QRD181J-103	CR
	R9	QRD181J-222	CR
	R10	QRD181J-822	CR
	R11	QRD181J-561	CR
	R12	QRD181J-331	CR
	R13	QRD181J-471	CR
	R14	QRD181J-271	CR
	R15	QVZ3521-331	VR, SWD 5.33 V DC
	R16	QRD181J-222	CR
	R17	-	-
	R18	QRD181J-222	CR
	R19	QRD181J-682	CR
	R20	QRD181J-272	CR

Δ REF. NO. PART NO. PART NAME, DESCRIPTION

R21 QRD181J-331 CR
 R22 QRD181J-331 CR
 R23 QRD181J-331 CR
 Δ R24 PU52108-470 POSISTOR

C1 - -
 C2 - -
 C3 - -
 C4 - -
 C5 QFN31HJ-103 MY CAP
 C6 QETC1HM-106 E CAP
 C7 QCS31HJ-470 C CAP
 C8 QFN31HJ-103 MY CAP
 C9 QETC1CM-107 E CAP
 C10 QETC1CM-336 E CAP
 C11 QETC1CM-107 E CAP
 C12 QETC1CM-336 E CAP
 C13 QCS31HJ-470 C CAP
 C14 QFN31HJ-103 MY CAP
 C15 QETC1AM-107 E CAP
 C16 QETC1JM-476 E CAP
 C17 QETC1JM-107 E CAP
 C18 QCS31HJ-470 C CAP
 C19 QETC1HM-226 E CAP
 C20 QETC1VM-226 E CAP

Δ CP2 ICP-N15 CIRCUIT PROTECTOR

CN1 PU58844-107 CAP. HOUSING
 CN2 PU58844-103 CAP. HOUSING
 CN3 PU58844-103R CAP. HOUSING
 CN4 PU58844-104 CAP. HOUSING
 CN5 PU58844-109 CAP. HOUSING
 CN6 PU58844-9 CAP. HOUSING

TAB A74017 TAB, GND

TP PU65774 TEST PIN, TP1-4

Δ REF. NO. PART NO. PART NAME, DESCRIPTION

.....
 PU11469B-02(E/EG) VIDEO/MECHACON/SERVO BOARD ASS'Y [03]
 PU11469A-02 (EK) VIDEO/MECHACON/SERVO BOARD ASS'Y [03]

- VIDEO SECTION -

IC401 HA11870NT INTEGRATED CIRCUIT
 IC402 PU222B2A Y. MODULE, JA016
 IC403 7VT12 INTEGRATED CIRCUIT

Q401 DTC144ES D. TRANSISTOR
 Q402 DTC144ES D. TRANSISTOR
 Q403 DTC144ES D. TRANSISTOR
 Q404 DTC144ES D. TRANSISTOR
 Q405 2SC1740S(QRS) TRANSISTOR
 Q406 2SC1740S(QRS) TRANSISTOR
 Q407 2SA1309R,S TRANSISTOR
 Q408 2SC1740S(QRS) TRANSISTOR
 Q409 DTC144WS D. TRANSISTOR
 Δ Q410 2SA1309R,S TRANSISTOR

Q411 DTC144WS D. TRANSISTOR
 Δ Q412 2SA1309R,S TRANSISTOR
 Q413 2SA1309R,S TRANSISTOR
 Q414 2SC1740S(QRS) TRANSISTOR
 Q415 2SC1740S(QRS) TRANSISTOR
 Q416 2SA1309R,S TRANSISTOR
 Q417 2SA1309R,S TRANSISTOR
 Q418 2SA1309R,S TRANSISTOR
 Q419 DTA144ES D. TRANSISTOR
 Q420 2SC1740S(QRS) TRANSISTOR

Q421 2SB810H,J TRANSISTOR
 Q422 DTC144WS D. TRANSISTOR
 Q423 2SC1740S(QRS) TRANSISTOR

D401 1SS133 DIODE
 D402 1SS133 DIODE
 D403 1SS133 DIODE
 D404 1SS133 DIODE
 D405 - -
 D406 1SS133 DIODE
 D407 1SS133 DIODE
 D408 1SS133 DIODE
 D409 OA90 DIODE
 D410 OA90 DIODE

D411 1SS133 DIODE
 D412 1SS133 DIODE
 D413 - -
 D414 1SS133 DIODE
 D415 1SS133 DIODE
 D416 1SS133 DIODE
 D417 1SS133 DIODE
 D418 1SS133 DIODE
 D419 1SS133 DIODE
 D420 1SS133 DIODE

#	REF. NO.	PART NO.	PART NAME, DESCRIPTION	#	REF. NO.	PART NO.	PART NAME, DESCRIPTION
	D421	1SS133	DIODE		R454	QRD161J-222	CR
	D422	1SS133	DIODE		R455	-	-
	D423	1SS133	DIODE		R456	QRD161J-102	CR
	D424	1SS133	DIODE		R457	QRD161J-223	CR
	D425	1SS133	DIODE		R458	QRD161J182	CR
	D426	1SS133	DIODE		R459	QRD161J-103	CR
					R460	QRD161J-103	CR
	R401	QRD161J-103	CR		R461	QRD161J-103	CR
	R402	QRD161J-153	CR		R462	QRD161J-473	CR
	R403	QRD161J-474	CR		R463	QRD161J-222	CR
	R404	QRD161J-223	CR		R464	QRD161J-122	CR
	R405	QRD161J-223	CR		R465	QRD161J-222	CR
	R406	QRD161J-103	CR		R466	QRD161J-102	CR
	R407	QRD161J-151	CR		R467	QRD161J-223	CR
	R408	QRD161J-151	CR		R468	QRD161J-223	CR
	R409	QRD161J-332	CR		R469	-	-
	R410	QRD162J-102	CR		R470	QRD161J-223	CR
	R411	QRD161J-332	CR		R471	QRD161J-223	CR
	R412	QRD161J-152	CR		R472	QRD161J-820	CR
	R413	QRD161J-222	CR		R473	QRD161J-152	CR
	R414	QRD161J-102	CR		R474	QRD161J-182	CR
	R415	QRD161J-101	CR		R475	QRD161J-182	CR
	R416	QVZ3518-222	VR, FREQ RESPONSE		R476	QRD161J-181	CR
	R417	QRD161J-391	CR		R477	QRD161J-124	CR
	R418	QRD161J-391	CR				
	R419	QRD161J-561	CR				
	R420	QRD161J-471	CR				
	R421	QRD161J-393	CR		C401	QCBB1HJ-471	C CAP
	R422	QRD161J-222	CR		C402	QCSB1HK-5R6	C CAP
	R423	QRD161J-103	CR		C403	QCVB1CN-103	C CAP
	R424	QRD161J-393	CR		C404	QET61HM-104	E CAP
	R425	QRD161J-222	CR		C405	QCF31HP-223	C CAP
	R426	QRD161J-393	CR		C406	QET60JM-476	E CAP
	R427	QRD161J-222	CR		C407	QCF31HP-223	C CAP
	R428	QRD161J-103	CR		C408	QET60JM-476	E CAP
	R429	-	-		C409	QCVB1CN-103	C CAP
	R430	QRD161J-225	CR		C410	QFZ0096-224	MP CAP
	R431	QRD161J-475	CR		C411	-	-
	R432	QRD161J-662	CR		C412	QCSB1HJ-220	C CAP
	R433	QRD161J-335	CR		C413	QFZ0096-224	MP CAP
	R434	QRD161J-562	CR		C414	QCVB1CN-103	C CAP
	R435	QRD161J-102	CR		C415	QCBB1HJ-121	C CAP
	R436	QVZ3518-102	VR, SP REC FM LEVEL		C416	QCVB1CN-103	C CAP
	R437	QRD161J-821	CR		C417	QCVB1CN-103	C CAP
	R438	QRD161J-152	CR		C418	QCBB1HJ-102	C CAP
	R439	QRD161J-272	CR		C419	QCSB1HK-5R6	C CAP
	R440	QRD161J-153	CR		C420	QCSB1HJ-101	C CAP
	R441	QRD161J-153	CR		C421	QCSB1HJ-180	C CAP
	R442	QRD161J-684	CR		C422	QCSB1HJ-470	C CAP
	R443	QRD161J-824	CR		C423	QCVB1CN-103	C CAP
	R444	QRD161J-102	CR		C424	QCSB1HJ-330	C CAP
	R445	QRD161J-222	CR		C425	-	-
	R446	QRD161J-331	CR		C426	QCF31HP-223	C CAP
	R447	QRD161J-151	CR		C427	QET60JM-476	E CAP
	R448	QRD161J-331	CR		C428	QCSB1HJ-330	C CAP
	R449	-	-		C429	QCBB1HJ-151	C CAP
	R450	QRD121J-391	CR		C430	QET61HM-105	E CAP
	R451	QRD161J-750	CR		C431	QET61HM-105	E CAP
	R452	QRD161J-102	CR		C432	-	-
	R453	QRD161J-102	CR		C433	QCBB1HJ-181	C CAP
					C434	QEM51AK-107	E CAP
					C435	QCVB1CN-103	C CAP

#	REF. NO.	PART NO.	PART NAME, DESCRIPTION	#	REF. NO.	PART NO.	PART NAME, DESCRIPTION
C436		QCBB1HJ-121	C CAP	LPF401		PU58021-2	LOW PASS FILTER
C437		QCBB1HJ-121	C CAP				
C438		QCSB1HJ-120	C CAP	DL401		PGZ00149	1H DELAY LINE
C439		QCBB1HK-102	C CAP				
C440		QET61HM-225	E CAP	EQ401		PU54838	EQUALIZER, E/EG
C441		QCBB1HJ-121	C CAP				
C442		QCSB1HJ-560	C CAP	△ PTH401		PU52108-1R0	POSISTOR
C443		QCSB1HJ-220	C CAP	TH401		ERT-D2FGL101S	THERMISTOR
C444		QET60JM-107	E CAP				
C445		QET60JM-107	E CAP	SLD401		PU59536	PRE SHIELD (4)
C446		QET61EM-335	E CAP	SLD402		PU59537	PRE SHIELD (2)
C447		QET61HM-105	E CAP	SLD403		PU59538	PRE SHIELD (3)
C448		QET61HM-225	E CAP				
C449		QET61HM-335	E CAP	SPC401		PQ41028-7	SPACER
C450		QET61HM-225	E CAP	H401		PU58018-1-2	BOARD HINGE, X3
C451		QET61CM-106	E CAP				
C452		QET61EM-335	E CAP	TAB		A74017	TAB, E/EG
C453		QCVB1CN-103	C CAP	TP		PU57545	TEST PIN, TP402, 406, 410, GND 1, GND 2
C454		QET61EM-475	E CAP				
C455		QETC0JM-477	E CAP	CN401		PU58844-6	CAP. HOUSING
C456		QET60JM-476	E CAP	CN402		PU58844-3	CAP. HOUSING
C457		QCF31HP-223	C CAP	CN403		-	-
C458		QET61CM-476	E CAP	CN404		PU58844-3	CAP. HOUSING
C459		QET61AM-476	E CAP	CN405		PU58844-3	CAP. HOUSING
C460		QET61CM-476	E CAP	CN406		PU58844-6	CAP. HOUSING, E/EG
C461		QET61CM-476	E CAP			PU58844-4	CAP. HOUSING, EK
C462		QCVB1CN-103	C CAP	CN407		PU58844-4	CAP. HOUSING
C463		-	-	CN408		-	-
C464		PU51163-151	C CAP	CN409		PU58844-2	CAP. HOUSING
C465		QCVB1CN-103	C CAP	CN410		PU58844-2	CAP. HOUSING
C466		QCVB1CN-103	C CAP				
C467		QFN41HJ-563	MY CAP	IC101		PU22046A	C. MODULE, JA005
C468		QCS11HJ-1R0	C CAP	IC102		BA7007	INTEGRATED CIRCUIT, E/EG
C469		QCSC1HJ-180	C CAP				
L401		PU48530-101K	PEAKING COIL	Q101		2SC1740S(QRS)	TRANSISTOR
L402		PU48530-101K	PEAKING COIL	Q102		2SC1740S(QRS)	TRANSISTOR
L403		PU59152-101J	PEAKING COIL	Q103		DTC144ES	D. TRANSISTOR
L404		PU59152-390J	PEAKING COIL	Q104		DTC144ES	D. TRANSISTOR
L405		PU59152-560J	PEAKING COIL	Q105		DTC144ES	D. TRANSISTOR
L406		PU59152-180J	PEAKING COIL	Q106		DTC144ES	D. TRANSISTOR
L407		PU59152-560J	PEAKING COIL	Q107		-	-
L408		PU48530-101K	PEAKING COIL	Q108		DTC144ES	D. TRANSISTOR
L409		PU59152-121J	PEAKING COIL	Q109		2SC1740S(QRS)	TRANSISTOR
L410		-	-	Q110		2SC1740S(QRS)	TRANSISTOR
L411		PU48530-151J	PEAKING COIL	Q111		2SC1740S(QRS)	TRANSISTOR, E/EG
L412		PU59152-221J	PEAKING COIL	Q112		2SC1740S(QRS)	TRANSISTOR, E/EG
L413		PU59152-470J	PEAKING COIL				
L414		PU59152-680J	PEAKING COIL				
L415		PU59152-560J	PEAKING COIL				
L416		PU59152-180J	PEAKING COIL				
L417		PU59152-180J	PEAKING COIL				
L418		PU48530-471J	PEAKING COIL				
L419		PU59152-121J	PEAKING COIL				
L420		PU48530-101K	PEAKING COIL				
L421		PU48530-101K	PEAKING COIL				
L422		PU48530-101K	PEAKING COIL				
L423		PU49993-6R8	COIL, E/EG				
L424		PU59152-470J	PEAKING COIL				

#	REF. NO.	PART NO.	PART NAME, DESCRIPTION	#	REF. NO.	PART NO.	PART NAME, DESCRIPTION
	D101	1SS133	DIODE		R147	QRD161J-182	CR, E/EG
	D102	1SS133	DIODE		R148	QVZ3518-472	VR, E/EG, SECAM DETECTOR
	D103	1SS133	DIODE		R149	QRD161J-103	CR, E/EG
	D104	1SS133	DIODE		R150	QRD161J-562	CR, E/EG
	D105	1SS133	DIODE				
	D106	1SS133	DIODE, E/EG		R151	QRD161J-333	CR, E/EG
	D107	1SS133	DIODE, E/EG		R152	QRD161J-393	CR, E/EG
	D108	1SS133	DIODE, E/EG		R153	QRD161J-102	CR, E/EG
	D109	1SS133	DIODE, E/EG		R154	-	-
	D110	1SS133	DIODE		R155	QRD161J-392	CR, E/EG
	D111	1SS133	DIODE				
	R101	QRD161J-102	CR		C101	QCVB1CN-103	C CAP
	R102	QRD161J-102	CR		C102	QCBB1HJ-271	C CAP
	R103	QRD161J-681	CR		C103	QCBB1HJ-101	C CAP
	R104	QRD161J-272	CR		C104	QCVB1CN-103	C CAP
	R105	QRD161J-102	CR		C105	QCC11CJ-473	C CAP
	R106	QRD161J-102	CR		C106	QCSB1HJ-470	C CAP
	R107	QRD161J-473	CR		C107	QET61CM-106	E CAP
	R108	QRD161J-102	CR		C108	QCVB1CN-103	C CAP
	R109	QRD161J-681	CR		C109	QCT25CH-220	C CAP
	R110	QVZ3518-331	VR, REC COLOUR LEVEL		C110	QCC11CJ-223	C CAP
	R111	QRD161J-222	CR		C111	QEK61HM-105	E CAP
	R112	QRD161J-122	CR		C112	QEK61EM-475	E CAP
	R113	QRD161J-223	CR		C113	QEK61EM-475	E CAP
	R114	QRD161J-223	CR		C114	QCSB1HJ-470	C CAP
	R115	QRD161J-472	CR		C115	QET61HM-105	E CAP
	R116	QRD161J-274	CR		C116	QET60JM-476	E CAP
	R117	QVZ3518-223	VR, VXO, 4.43MHz		C117	QET61EM-475	E CAP
	R118	QRD161J-223	CR		C118	QCVB1CN-103	C CAP
	R119	QRD161J-333	CR		C119	QET61EM-335	E CAP
	R120	QRD161J-103	CR		C120	QCC11CJ-473	C CAP
	R121	QRD161J-103	CR		C121	QCC11CJ-563	C CAP
	R122	QRD161J-393	CR		C122	QET61CM-106	E CAP
	R123	QRD161J-122	CR		C123	QCC118K-224	C CAP
	R124	QRD161J-391	CR		C124	QEK61HM-225	E CAP
	R125	-	-		C125	QEK61CM-106	E CAP
	R126	-	-		C126	QCVB1CN-103	C CAP
	R127	QRD161J-221	CR		C127	QCBB1HJ-102	C CAP
	R128	-	-		C128	QCBB1HJ-102	C CAP
	R129	QRD161J-332	CR		C129	QCSB1HJ-100	C CAP
	R130	QRD161J-561	CR		C130	QCVB1CN-103	C CAP
	R131	QRD161J-561	CR		C131	QEK60JM-476	E CAP
	R132	QRD161J-102	CR		C132	QCF31HP-223	C CAP, E/EG
	R133	QRD161J-122	CR		C133	QEK61CM-476	E CAP, E/EG
	R134	QRD161J-471	CR		C134	QET61AM-336	E CAP, E/EG
	R135	QRD161J-152	CR		C135	QCC11CJ-182	C CAP, E/EG
	R136	QRD161J-223	CR		C136	QCXB1CN-272	C CAP, E/EG
	R137	QRD161J-682	CR		C137	QCC11CJ-223	C CAP, E/EG
	R138	QRD161J-102	CR		C138	QET61CM-106	E CAP, E/EG
	R139	QRD161J-181	CR		C139	QCVB1CN-103	C CAP, E/EG
	R140	QRD161J-391	CR				
	R141	QRD161J-331	CR		L101	-	-
	R142	QRD161J-822	CR, E/EG		L102	PU48530-222J	PEAKING COIL
	R143	QRD161J-393	CR, E/EG		L103	PU48530-271J	PEAKING COIL
	R144	QRD161J-332	CR, E/EG		L104	PU48530-101K	PEAKING COIL
	R145	QRD161J-154	CR, E/EG		L105	PU48530-101K	PEAKING COIL
	R146	QRD161J-563	CR, E/EG		L106	PU47051-822	COIL
					L107	PU59152-150J	PEAKING COIL

#	REF. NO.	PART NO.	PART NAME, DESCRIPTION	#	REF. NO.	PART NO.	PART NAME, DESCRIPTION
	L108	PU59152-560J	PEAKING COIL		D201	10E2	DIODE
	L109	PU48530-101K	PEAKING COIL		OR	11E2	DIODE
	L110	PU47051-562	COIL, E/EG		D202	MTZ6.8B	ZENER DIODE
	L111	PU49057	LC BLOCK, E/EG, Fh/2		OR	RD6.8ES-T1B2	ZENER DIODE
	L112	PU48530-101K	PEAKING COIL, E/EG		D203	MTZ6.8B	ZENER DIODE
					OR	RD6.8ES-T1B2	ZENER DIODE
	LCF101	PU59533	LC FILTER		D204	1SS133	DIODE
					D205	1SS133	DIODE
	LPF101	PU68022	LOW PASS FILTER		D206	MTZ7.5B	ZENER DIODE
					OR	RD7.5ES-T1B2	ZENER DIODE
	BPF101	PU59534	BAND PASS FILTER		D207	HZS4.3EB2	ZENER DIODE
					D208	MA27TA	DIODE
					D209	1SS133	DIODE
					D210	DAN209S	DIODE ARRAY
					D211	1SS133	DIODE
					D212	-	-
					D213	-	-
					D214	RD5.6ES-T1B1	ZENER DIODE
					OR	MTZ5.6A	ZENER DIODE
					D215	MTZ10A	ZENER DIODE
					OR	RD10ES-T1B1	ZENER DIODE
					D216	1SS133	DIODE
					R201	QRD161J-223	CR
					R202	QRD161J-332	CR
					R203	QRD161J-332	CR
					R204	QRD161J-223	CR
					R205	QRX019J-4R7S	MFR
					R206	QRD161J-682	CR
					R207	QRD161J-103	CR
					R208	QRD161J-153	CR
					R209	QRD161J-103	CR
					R210	QRD161J-103	CR
					R211	QRD161J-103	CR
					R212	QRD161J-103	CR
					R213	QRD161J-103	CR
					R214	QRD161J-104	CR
					R215	QRD161J-332	CR
					R216	QRD161J-332	CR
					R217	QRD161J-472	CR
					R218	QRD161J-152	CR
					R219	QRD161J-472	CR
					R220	QRD161J-103	CR
					R221	-	-
					R222	QRD161J-562	CR
					R223	QRD161J-103	CR
					R224	QRD161J-103	CR
					R225	QRD161J-103	CR
					R226	QRD161J-103	CR
					R227	QRD161J-103	CR
					R228	QRD161J-103	CR
					R229	QRD161J-105	CR
					R230	QRD161J-472	CR
					R231	QRD161J-124	CR
					R232	QRD161J-124	CR
					R233	QRD161J-333	CR
					R234	QRD161J-333	CR
					R235	QRD161J-333	CR
					R236	QRD161J-1R0	CR

- MECHACON SECTION -

	IC201	M50965-614SP	INTEGRATED CIRCUIT
	IC202	M54644AL	INTEGRATED CIRCUIT
		OR M54644BL	INTEGRATED CIRCUIT
	IC203	TA8400P	INTEGRATED CIRCUIT
	IC204	M54644BL	INTEGRATED CIRCUIT
	Q201	2SA933S(RS)	TRANSISTOR
	Q202	2SD1292T103Q,R	TRANSISTOR
		OR 2SC2655O,Y	TRANSISTOR
	Q203	2SC2655O,Y	TRANSISTOR
		OR 2SD1292T103Q,R	TRANSISTOR
	Q204	2SA933S(RS)	TRANSISTOR
	Q205	2SC1741S(R)	TRANSISTOR
	Q206	DTC124ES	D. TRANSISTOR
	Q207	2SK656	D. MOS FET
	Q208	DTA124ES	D. TRANSISTOR, EK ONLY
	Q209	DTA124ES	D. TRANSISTOR

#	REF. NO.	PART NO.	PART NAME, DESCRIPTION
R25		QRD161J-102	CR
R26		QRD161J-333	CR
R27		QVZ3518-474	VR, PB SWITCHING POINT
R28		QRD161J-103	CR
R29		QVZ3521-474	VR, V LOCK
R30		QRD161J-102	CR
R31		QRD161J-472	CR
R32		QRD161J-223	CR
R33		QRD161J-681	CR
R34		QRD161J-564	CR
R35		QRD161J-103	CR
R36		QRD161J-103	CR
R37		QRD161J-105	CR
R38		QRD161J-681	CR
R39		QRD161J-102	CR
R40		QRD161J-331	CR
R41		QRD161J-684	CR
R42		QRD161J-102	CR
R43		QRD161J-103	CR
R44		QRD161J-223	CR
R45		QRD161J-105	CR
R46		QRD161J-104	CR
R47		QRD161J-332	CR
R48		QRD161J-102	CR
R49		QRD161J-105	CR
R50		QRD161J-333	CR
R51		QRD161J-101	CR
R52		QRD161J-153	CR
R53		QRD161J-104	CR
R54		QRD161J-104	CR
R55		QRD161J-103	CR
R56		QRD161J-472	CR
R57		QRD161J-472	CR
R58		QRD161J-185	CR
C1		QFN31HK-272	MY CAP
C2		-	-
C3		QFN31HJ-473	MY CAP
C4		QFN31HK-223	MY CAP
C5		QCXB1CN-472	C CAP
C6		QCXB1CN-472	C CAP
C7		QFN31HK-473	MY CAP
C8		QFN31HK-473	MY CAP
C9		QCXB1CN-103	C CAP
C10		QFN31HK-473	MY CAP
C11		QFN31HK-473	MY CAP
C12		QCXB1CN-472	C CAP
C13		QCXB1CN-472	C CAP
C14		QETC1EM-475	E CAP
C15		QETC1EM-475	E CAP
C16		QETC1EM-475	E CAP
C17		QETC1EM-475	E CAP
C18		QCBB1HJ-101	C CAP
C19		QFN31HJ-882	MY CAP
C20		QFN31HK-102	MY CAP
C21		QFN31HJ-154	MY CAP
C22		QFN31HK-104	MY CAP
C23		QETC1CM-106	E CAP

#	REF. NO.	PART NO.	PART NAME, DESCRIPTION
C24		QCBB1HJ-102	C CAP
C25		QCBB1HJ-102	C CAP
C26		QETC1HM-225	E CAP
C27		QCBB1HJ-102	C CAP
C28		QETC1CM-106	E CAP
C29		QETC1AM-476	E CAP
C30		QETC1CM-106	E CAP
C31		QETC1CM-106	E CAP
C32		QCBB1HJ-102	C CAP
C33		QETC1AM-476	E CAP
C34		QETC1EM-475	E CAP
C35		QFN31HK-104	MY CAP
C36		QCBB1HJ-101	C CAP
C37		QEN61HM-105	NP CAP
C38		QETC1HM-225	E CAP
C39		QCBB1HJ-102	C CAP
C40		QEN61HM-105	NP CAP
C41		QCXB1CN-103	C CAP
C42		QCXB1CN-103	C CAP
C43		QCXB1CN-103	C CAP
C50		QETA1CM-477	E CAP
TP		PU57545	TEST PIN, TP1, 11, 12, GND
CN1		PU58844-2	CAP. HOUSING
CN2		PU58844-5	CAP. HOUSING
CN3		PU58844-2	CAP. HOUSING
Q1		2SA1309R,S	TRANSISTOR, E/EG
D1		1SS133	DIODE
D2		1SS133	DIODE, EK ONLY
D3		1SS133	DIODE, EK ONLY
D4		1SS133	DIODE, EK ONLY
D5		-	-
D6		1SS133	DIODE, E/EG
D7		1SS133	DIODE, E/EG
R1		QRD161J-750	CR
R2		QRD161J-331	CR
R3		QRD161J-331	CR
R4		QRD161J-102	CR
R5		QRD161J-102	CR
R6		QRD161J-102	CR

#	REF. NO.	PART NO.	PART NAME, DESCRIPTION
R31		QRD161J-102	CR, EK ONLY
R32		QVZ3518-332	VR, EK ONLY, AUDIO LEVEL
R33		QRD161J-562	CR, EK ONLY
R34		QRD161J-103	CR, EK ONLY
R35		QRD161J-182	CR, EK ONLY
R36		-	-
R37		-	-
R38		-	-
R39		-	-
R40		QRD161J-182	CR
R41		QRD161J-272	CR
R42		QVZ3518-103	VR, COLOUR LEVEL
R43		QRD161J-123	CR
R44		QRD161J-123	CR
R45		QRD161J-331	CR
R46		QRD161J-222	CR
R47		-	-
R48		-	-
R49		QRD161J-331	CR, E/EG
R50		QRD161J-680	CR, E/EG
R51		QRD161J-222	CR, E/EG
R52		QRD161J-471	CR
R53		QRD161J-103	CR
R54		QRD161J-332	CR
R55		QRD161J-680	CR
R56		QRD161J-102	CR
R57		QRD161J-471	CR
R58		QRD161J-223	CR
R59		QRD161J-223	CR
R60		QRD161J-103	CR
R61		QRD161J-334	CR
R62		QRD161J-103	CR
R75		QRD161J-472	CR, E/EG
R76		QRD161J-153	CR, E/EG
R77		QRD161J-123	CR, E/EG
R78		QRD161J-472	CR, E/EG
R79		QRD161J-153	CR, E/EG
R80		QRD161J-123	CR, E/EG
R81		QRD161J-472	CR, E/EG
		QRD161J-104	CR, EK
R82		QRD161J-153	CR, E/EG
R83		QRD161J-123	CR, E/EG
R84		QRD161J-472	CR, E/EG
R85		QRD161J-153	CR, E/EG
R86		QRD161J-123	CR, E/EG
R87		QRD161J-104	CR, E/EG
R88		QRD161J-153	CR
R89		QRD161J-752	CR, E/EG
R90		QRD161J-101	CR
R91		QRD161J-472	CR
R92		QRD161J-562	CR
R93		QRD161J-152	CR
R94		QRD161J-472	CR
R95		QRD161J-121	CR
R96		QRD161J-103	CR
R97		QRD161J-103	CR
R98		QRD161J-153	CR
R99		QRD161J-331	CR

#	REF. NO.	PART NO.	PART NAME, DESCRIPTION
R100		QRD161J-101	CR
R101		QRD161J-222	CR
R102		QRD161J-222	CR
R103		QRD161J-222	CR
R104		QRD161J-222	CR
R105		QRD161J-222	CR
R106		QRD161J-102	CR
R107		QRD161J-472	CR, E/EG
		QRD161J-222	CR, EK
R108		QRD161J-103	CR, E/EG
R109		-	-
R110		QRD161J-104	CR
R111		QRD161J-104	CR
R112		QRD161J-222	CR
R130		QRD161J-331	CR
R131		QRD161J-102	CR
R132		QRD161J-101	CR
R133		QRD161J-153	CR
R134		QRD161J-182	CR
R140		QRD161J-392	CR, E/EG
R141		QRD161J-222	CR, E/EG
R142		QRD161J-331	CR, E/EG
C1		QCSB1HJ-100	C CAP, E/EG
C2		QCBB1HK-102	C CAP
C3		QCXB1CK-222	C CAP
C4		QCBB1HK-102	C CAP
C5		QCBB1HK-102	C CAP
C6		-	-
C7		PU57601-474ME	OS CAP
C8		QETC1CM-336	E CAP
C9		QCXB1CK-222	C CAP
C10		QCSB1HJ-470	C CAP, E/EG
		QCSB1HJ-220	C CAP, EK
C11		QETC1HM-474	E CAP
C12		QCT25PH-270	C CAP, E/EG
		QCT25RH-220	C CAP, EK
C13		QCXB1CK-222	C CAP
C14		QETC1CM-336	E CAP
C15		-	-
C16		-	-
C17		-	-
C18		-	-
C19		QETC1CM-336	E CAP, EK ONLY
C20		QCXB1CK-222	C CAP, EK ONLY
C21		QCF31HP-223	C CAP, EK ONLY
C22		QCSB1HJ-100	C CAP, EK ONLY
C23		QETC1HM-105	E CAP
C24		QFN31HK-393	MY CAP, EK ONLY
C25		QETC1HM-105	E CAP, EK ONLY
C26		-	-
C27		QETC1HM-335	E CAP, EK ONLY
C28		-	-
C29		-	-
C30		QETC1CM-336	E CAP

#	REF. NO.	PART NO.	PART NAME, DESCRIPTION	#	REF. NO.	PART NO.	PART NAME, DESCRIPTION
C31		QCSB1HJ-470	C CAP	L11		PU59152-R22K	PEAKING COIL, E/EG
C32		-	-		OR	PU53223-R22K	PEAKING COIL, E/EG
C33		-	-				
C34		QETC1CM-336	E CAP, E/EG	△ T1		PU59402	TRAP COIL, FTZ TRAP, E/EG
C35		QETC1CM-106	E CAP	T2		PU59308	COIL, VCO
C36		QCC11EK-223	C CAP	T3		-	-
C37		QETC1HM-474	E CAP	T4		PU59644	F.H. TRAP, EK ONLY
C38		-	-	T5		PU59639	IFT, SYNC DET
C39		QCC11CK-104	C CAP				
C40		QETC1CM-106	E CAP, E/EG	CF1		PU57707	CERAMIC FILTER, EK ONLY
C41		QETC1CM-106	E CAP, E/EG	CF2		PU59242-3	CERAMIC FILTER, EK ONLY, 6.0 MC29
C42		QETC1CM-106	E CAP, E/EG	△ CF3		PU32990-2	CERAMIC FILTER, E/EG
		QETC1HM-225	E CAP, EK			PU32990-3	CERAMIC FILTER, EK, T 6.0
C43		QETC1CM-106	E CAP	RA1		QRB047J-104	RESISTOR ARRAY
C44		QETC1HM-225	E CAP, E/EG	△ CP1		ICP-F15	CIRCUIT PROTECTOR
C45		-	-				
C46		QFV81HJ-474	MY CAP	SAW1		PU35557-4	SAW FILTER, E/EG
	OR	QFZ9011-474	MP CAP			PU32987-4	SAW FILTER, EK
C47		QFN31HJ-223	MY CAP, E/EG	△ X1		PU58554-2	CRYSTAL, 4.0 MHz
		QFN31HK-223	MY CAP, EK	△ TNR		PU36155-1-2	U/V TUNER, E/EG
C48		QCB81HK-102	C CAP	△		PU36180	UHF TUNER, EK
C49		QCB81HK-102	C CAP				
C50		-	-	SLD1		PU36322	SHIELD CASE
C51		QCT25CH-220	C CAP	SLD2		PQ31328-1-1	SHIELD COVER
C52		QCT25CH-270	C CAP	SLD3		PU59761-1-1	SHIELD PLATE
C53		QCVB1CN-103	C CAP	SPC1		PQM30029-87	SPACER
C54		-	-			PU57295-022	COAXIAL CORD, EK ONLY
C55		QETC1CM-106	E CAP	△ RF1		PU59429M	RF CONVERTER & MIX BOOSTER, E/EG
C56		QETC1CM-336	E CAP	△		PU58053S-03	RF CONVERTER & MIX BOOSTER, EK
C57		QET61CM-337	E CAP, E/EG				
C58		QCB81HK-102	C CAP	CN1		PU58844-7	CAP. HOUSING
C59		QETC1AM-336	E CAP, E/EG	CN2		PU58844-3	CAP. HOUSING, E/EG
		QET61AM-336	E CAP, EK			PU58844-5	CAP. HOUSING, EK
C60		-	-	CN3		PU58844-3R	CAP. HOUSING, E/EG
C61		QET61AM-106	E CAP	CN4		PU58844-3	CAP. HOUSING, E/EG
C62		-	-	CN5		PU58844-4	CAP. HOUSING
C63		QETC1HM-106	E CAP	CN6		-	-
C64		PU57601-475MA	OS CAP	CN7		PU59374	CAP. HOUSING, E/EG
C65		QETC1CM-336	E CAP				
C66		-	-				
C67		-	-				
C68		-	-				
C69		-	-				
C70		QCXB1CK-222	C CAP, E/EG				
C71		QC881HK-102	C CAP, E/EG				
L1		PU59152-R22M	PEAKING COIL, E/EG				
L2		PU57717-1R0J	PEAKING COIL, E/EG				
		PU57717-1R2	PEAKING COIL, EK				
L3		PU57717-1R5J	PEAKING COIL, E/EG				
		PU57717-1R5	PEAKING COIL, EK				
L4		PU59152-6R8K	PEAKING COIL				
L5		PU59152-120J	PEAKING COIL, E/EG				
		PU59152-150J	PEAKING COIL, EK				
L6		PU59152-6R8K	PEAKING COIL				
L7		PU59152-6R8K	PEAKING COIL, EK ONLY				
L8		PU59152-220J	PEAKING COIL				
L9		-	-				
L10		PU59152-100J	PEAKING COIL				

#	REF. NO.	PART NO.	PART NAME, DESCRIPTION	#	REF. NO.	PART NO.	PART NAME, DESCRIPTION
		PU11433D (E/EG)	AUDIO (FMA/NOR) BOARD ASS'Y (09)		D12	1SS133	DIODE
		PU11433C (EK)	AUDIO (FMA/NOR) BOARD ASS'Y (09)		OR MA165		DIODE
	IC1	AN6299K	INTEGRATED CIRCUIT		D13	1SS133	DIODE
	IC2	AN3826K	INTEGRATED CIRCUIT		OR MA165		DIODE
	IC3	HA11752	INTEGRATED CIRCUIT		D14	1SS133	DIODE
	IC4	AN3930K	INTEGRATED CIRCUIT		OR MA165		DIODE
	IC5	H8D1951A	INTEGRATED CIRCUIT		D15	-	-
	IC6	AN3994NK	INTEGRATED CIRCUIT		D16	1SS133	DIODE
	IC7	BA3707	INTEGRATED CIRCUIT		OR MA165		DIODE
					D17	1SS133	DIODE
					OR MA165		DIODE
	Q1	DTA143EF	D. TRANSISTOR		R1	QRD161J-103	CR
△	Q2	2SD973R	TRANSISTOR		R2	QRD161J-103	CR
	Q3	2SB643R,S	TRANSISTOR		R3	-	-
	Q4	DTC144EF	D. TRANSISTOR		R4	-	-
△	Q5	2SA854S(QR)	TRANSISTOR		R5	-	-
△	Q6	2SD973R	TRANSISTOR		R6	-	-
△	Q7	2SA854S(QR)	TRANSISTOR		R7	QRD161J-331	CR
	Q8	DTA114YF	D. TRANSISTOR		R8	QRD161J-392	CR
	Q9	2SB643Q,R,S	TRANSISTOR		R9	QRD161J-272	CR
	Q10	2SD638Q,R,S	TRANSISTOR		R10	QRD161J-152	CR
	Q11	2SC2021R,S	TRANSISTOR		R11	QRD161J-182	CR
	Q12	2SC2021R,S	TRANSISTOR		R12	QRD161J-392	CR
	Q13	2SC2021R,S	TRANSISTOR		R13	QRD161J-821	CR
	Q14	2SC2021R,S	TRANSISTOR		R14	QRD161J-682	CR
	Q15	2SC2021Q,R,S	TRANSISTOR		R15	QRD161J-123	CR
	Q16	2SC2021Q,R,S	TRANSISTOR		R16	QRD161G-513	CR
	Q17	2SC2021R,S	TRANSISTOR		R17	QRD161J-123	CR
	Q18	DTA114YF	D. TRANSISTOR		R18	QRD161J-153	CR
	Q19	DTA114YF	D. TRANSISTOR		R19	QRD161J-272	CR
	Q20	2SD958S,T	TRANSISTOR		R20	QRD161J-152	CR
	Q21	2SD958S,T	TRANSISTOR		R21	QRD161J-182	CR
△	Q22	DTA114EN	D. TRANSISTOR		R22	QRD161J-392	CR
	Q23	2SD636Q,R,S	TRANSISTOR		R23	QRD161J-821	CR
	Q24	DTA114YF	D. TRANSISTOR		R24	QRD161J-682	CR
					R25	QRD161J-123	CR
					R26	QRD161G-513	CR
	D1	1SS133	DIODE		R27	QRD161J-153	CR
	OR MA165		DIODE		R28	QRD161J-123	CR
	D2	1SS133	DIODE		R29	QRD161J-102	CR
	OR MA165		DIODE		R30	QRD161J-151	CR
	D3	1SS133	DIODE		R31	QRD161J-225	CR
	OR MA165		DIODE		R32	QVZ3518-472	VR, L IND LEVEL
	D4	1SS133	DIODE		R33	QRD161J-392	CR
	OR MA165		DIODE		R34	-	-
	D5	-	-		R35	QRD161J-473	CR
	D6	1SS133	DIODE		R36	QRD161J-102	CR
	OR MA165		DIODE		R37	QRD161J-151	CR
	D7	1SS133	DIODE		R38	QRD161J-225	CR
	OR MA165		DIODE		R39	QVZ3518-472	VR, R IND LEVEL
	D8	1SS133	DIODE		R40	QRD161J-102	CR
	OR MA165		DIODE		R41	QRD161J-102	CR
	D9	1SS133	DIODE		R42	QRD161J-102	CR
	OR MA165		DIODE		R43	QRD161J-222	CR
	D10	1SS133	DIODE		R44	QRD161J-222	CR
	OR MA165		DIODE		R45	QRD161J-102	CR
	D11	1SS133	DIODE		R46	QRD161J-100	CR
	OR MA165		DIODE		R47	QRD161J-100	CR

#	REF. NO.	PART NO.	PART NAME, DESCRIPTION	#	REF. NO.	PART NO.	PART NAME, DESCRIPTION
R48	QRD161J-152	CR		R107	QVZ3518-103	VR, R PB LEVEL	
R49	QRD161J-472	CR		R108	-	-	
R50	QRD161J-332	CR		R109	QRD161J-563	CR	
R51	QRD161J-332	CR		R110	QRD161J-472	CR	
R52	QRD161J-152	CR		R111	QRD161J-223	CR	
R53	QRD161J-102	CR		R112	QRD161J-102	CR	
R54	QVZ3518-332	VR, REC FM LEVEL		R113	QRD161J-103	CR	
R55	QRD161J-103	CR		R114	QRD161J-103	CR	
R56	QRD161J-392	CR		R115	-	-	
R57	QRD161J-392	CR		R116	QRD161J-472	CR	
R58	QRD161J-271	CR		R117	QRD161J-103	CR	
R59	QRD161J-152	CR		R118	QRD161J-274	CR	
R60	QRD161J-100	CR		R119	QRD161J-331	CR	
R61	QRD161J-100	CR		R120	QVZ3518-102	VR, NORMAL PB LEVEL	
R62	QRD161J-681	CR		R121	QRD161J-333	CR	
R63	QRD161J-681	CR		R122	QRD161J-471	CR	
R64	QRD161J-223	CR		R123	QRD161J-333	CR	
R65	QRD161J-223	CR		R124	QRD161J-331	CR	
R66	QRD161J-681	CR		R125	QRD161J-470	CR	
R67	QRD161J-224	CR		R126	QRD161J-100	CR	
R68	QRD161J-223	CR		R127	QRD161J-361	CR	
R69	QRD161J-562	CR		R128	QVZ3518-473	VR, BIAS LEVEL	
R70	QRD161J-472	CR		R129	QRD161J-333	CR	
R71	QRD161J-821	CR		R130	QRD161J-4R7	CR	
R72	QRD161J-471	CR		R131	QRD161J-102	CR	
R73	QRD161J-102	CR		R132	QRD161J-224	CR	
R74	QRD161J-102	CR		R133	QRD161J-104	CR	
R75	QRD161J-683	CR		R134	QRD161J-822	CR	
R76	QRD161J-103	CR		R135	QRD161J-223	CR	
R77	-	-		R136	QRD161J-152	CR	
R78	QRD161J-332	CR		R137	QRD161J-102	CR	
R79	QRD161J-271	CR		R138	QRD161J-104	CR	
R80	-	-		R139	QRD161J-102	CR	
R81	-	-		R140	QRD161J-104	CR	
R82	-	-		R141	QRD161J-223	CR	
R83	QRD161J-562	CR		R142	QRD161J-122	CR	
R84	QRD161J-182	CR		R143	QRD161J-102	CR	
R85	QRD161G-162	CR		R144	QRD161J-333	CR	
R86	-	-		R145	QRD161J-823	CR	
R87	QRD161J-224	CR		R146	QRD161J-184	CR	
R88	QRD161J-752	CR		R147	QVZ3518-473	VR, R CH E-E	
R89	QVZ3520-332	VR, L fo (1.4 MHz)		R148	QVZ3518-473	VR, L CH E-E	
R90	QRD161J-472	CR		R149	QRD161J-223	CR	
R91	QRD161J-182	CR		R150	QRD161J-272	CR	
R92	QRD161J-102	CR		R151	-	-	
R93	QRD161J-102	CR		R152	-	-	
R94	QRD161J-182	CR		R153	-	-	
R95	QVZ3520-332	VR, R fo (1.8 MHz)		R154	-	-	
R96	QRD161J-332	CR		R155	QRD161J-124	CR	
R97	QRD161J-272	CR		R156	QRD161J-103	CR	
R98	QRD161G-162	CR		R157	QRD161J-103	CR	
R99	QRD161J-182	CR		R158	QRD161J-472	CR	
R100	QRD161J-562	CR		R159	QRD161J-472	CR	
R101	QRD161J-224	CR		R160	-	-	
R102	QRD161J-222	CR		R161	QRD161J-683	CR	
R103	QVZ3518-103	VR, L PB LEVEL		R162	QRD161J-563	CR	
R104	QRD161J-334	CR		R163	QRD161J-8R2	CR	
R105	QRD161J-333	CR		R164	QRD161J-102	CR	
R106	QRD161J-222	CR		R165	QRD161J-102	CR	

#	△	REF. NO.	PART NO.	PART NAME, DESCRIPTION	#	△	REF. NO.	PART NO.	PART NAME, DESCRIPTION
		R166	QRD161J-102	CR			C36	QCF31HP-103	C CAP
		R167	QRD161J-334	CR			C37	QETC1CM-336	E CAP
		R168	QRD161J-124	CR			C38	QETC1CM-106	E CAP
		R169	QRD161J-272	CR			C39	QETC1CM-106	E CAP
	△	R170	QRD161J-331	CR			C40	QETC1CM-106	E CAP
		R171	QRD161J-223	CR			C41	QETC1HM-105	E CAP
	△	R172	QRD161J-122	CR			C42	QETC1HM-335	E CAP
		R173	QRD161J-103	CR			C43	QETC1HM-105	E CAP
		R174	QRD161J-562	CR			C44	QETC1HM-335	E CAP
		R175	QRD161J-103	CR			C45	QETC1CM-106	E CAP
		R176	QRD161J-682	CR			C46	QCF31HP-103	C CAP
		R177	QRD161J-472	CR			C47	QETC1CM-476	E CAP
		R178	QRD161J-122	CR			C48	QETC1CM-336	E CAP
		R179	QRD161J-122	CR			C49	QETC1CM-106	E CAP
		R180	QRD161J-472	CR			C50	QETC1CM-106	E CAP
		R181	QRD161J-682	CR			C51	QETC1CM-106	E CAP
							C52	QETC1CM-106	E CAP
							C53	QETC1AM-476	E CAP
	△	R201	QRZ0052-100	FR			C54	QCF31HP-102	C CAP
	△	R202	QRD161J-102	CR			C55	QETC1CM-476	E CAP
	△	R203	PU52108-6R8K	POSISTOR			C56	QCF31HP-103	C CAP
	△		OR PU52108-6R8	POSISTOR			C57	QCF31HP-103	C CAP
							C58	QCF31HP-103	C CAP
							C59	QCF31HP-103	C CAP
							C60	-	-
		C1	QETC1EM-335	E CAP			C61	QCF31HP-103	C CAP
		C2	QETC1CM-107	E CAP			C62	QCF31HP-103	C CAP
		C3	QETC1HM-225	E CAP			C63	QCF31HP-103	C CAP
		C4	QETC1CM-107	E CAP			C64	QCF31HP-103	C CAP
		C5	QETC1HM-225	E CAP			C65	QCF31HP-103	C CAP
		C6	QETC1CM-106	E CAP			C66	QCF31HP-103	C CAP
		C7	-	-			C67	QCS31HJ-561	C CAP
		C8	QFN31HJ-103	MY CAP			C68	QCS31HJ-561	C CAP
		C9	QFN31HJ-122	MY CAP			C69	QCF31HP-223	C CAP
		C10	QETC1CM-106	E CAP			C70	QCF31HP-223	C CAP
		C11	QCS31HJ-151	C CAP			C71	QCF31HP-103	C CAP
		C12	QETC1AM-336	E CAP			C72	QETC1AM-476	E CAP
		C13	QFN31HJ-333	MY CAP			C73	QCF31HP-102	C CAP
		C14	QETC1AM-336	E CAP			C74	QCS31HJ-331	C CAP
		C15	QETC1HM-225	E CAP			C75	QCF31HP-103	C CAP
		C16	QETC1AM-336	E CAP			C76	QCF31HP-103	C CAP
		C17	QETC1AM-336	E CAP			C77	QCF31HP-103	C CAP
		C18	QFN31HJ-153	MY CAP			C78	QETC1AM-476	E CAP
		C19	-	-			C79	-	-
		C20	QETC1CM-476	E CAP			C80	QCF31HP-103	C CAP
		C21	QETC1HM-225	E CAP			C81	QETC1HM-105	E CAP
		C22	QETC1HM-225	E CAP			C82	-	-
		C23	QETC1CM-106	E CAP			C83	QFN31HJ-103	MY CAP
		C24	-	-			C84	-	-
		C25	QETC1CM-106	E CAP			C85	QETC1AM-336	E CAP
		C26	QFN31HJ-122	MY CAP			C86	QCT25CH-101	C CAP
		C27	QFN31HJ-103	MY CAP			C87	QFN31HJ-182	MY CAP
		C28	QFN31HJ-151	MY CAP			C88	QETC1AM-336	E CAP
		C29	QETC1AM-336	E CAP			C89	QCF31HP-103	C CAP
		C30	QFN31HJ-333	MY CAP			C90	QCF31HP-103	C CAP
		C31	QETC1AM-336	E CAP			C91	QFN31HJ-182	MY CAP
		C32	QETC1HM-225	E CAP			C92	QETC1AM-336	E CAP
		C33	QETC1AM-336	E CAP			C93	QCT25CH-101	C CAP
		C34	QETC1AM-336	E CAP			C94	-	-
		C35	QFN31HJ-153	MY CAP					

#	REF. NO.	PART NO.	PART NAME, DESCRIPTION
		PU22418A-02	DEMODULATOR BOARD ASS'Y (14)
		(E/EG ONLY)	
△	IC1	M51365SP	INTEGRATED CIRCUIT
	IC2	TDA3800GS	INTEGRATED CIRCUIT
	Q1	2SC26550,Y	TRANSISTOR
		OR 2SD1292Q,R	TRANSISTOR
	Q2	-	-
	Q3	2SC3354S,T	TRANSISTOR
	Q4	2SC3354S,T	TRANSISTOR
	Q11	DTC114ES	D. TRANSISTOR
	Q12	DTC114ES	D. TRANSISTOR
	Q13	DTC114ES	D. TRANSISTOR
	Q14	DTC114ES	D. TRANSISTOR
	Q15	2SD1450S,T	TRANSISTOR
	Q16	2SD1450S,T	TRANSISTOR
	Q17	2SC3311AR,S	TRANSISTOR
	Q18	2SC3311AR,S	TRANSISTOR
	Q19	DTC144ES	D. TRANSISTOR
	Q20	DTC114ES	D. TRANSISTOR
	D1	-	-
	D2	1SS133	DIODE
	D3	-	-
	D4	-	-
	D5	1SS133	DIODE
	D6	1SS133	DIODE
	D7	1SS133	DIODE
	R1	QRD161J-561	CR
	R9	QRD161J-331	CR
	R10	-	-
	R11	QRD161J-561	CR
	R12	QRD161J-101	CR
	R13	QRD161J-330	CR
	R14	QRD161J-101	CR
	R15	QRD161J-471	CR
	R16	QRD161J-821	CR
	R17	-	-
	R18	QRD161J-824	CR
	R19	-	-
	R20	-	-
	R21	QRD161J-822	CR
	R22	QRD161J-222	CR
	R23	QRD161J-272	CR
	R24	QRD161J-223	CR
	R25	-	-
	R26	QRD161J-470	CR
	R27	QRD161J-561	CR
	R28	-	-
	R29	-	-

#	REF. NO.	PART NO.	PART NAME, DESCRIPTION
	R30	-	-
	R31	QVZ3518-103	VR, SEPARATION
	R32	QRD161J-331	CR
	R33	QRD161J-331	CR
	R34	-	-
	R35	-	-
	R36	QRD161J-471	CR
	R42	QRD161J-103	CR
	R43	QRD161J-103	CR
	R44	QRD161J-123	CR
	R45	QRD161J-821	CR
	R46	QRD161J-102	CR
	R47	-	-
	R48	QRD161J-273	CR
	R49	-	-
	R50	-	-
	R51	QRD161J-103	CR
	R52	QRD161J-103	CR
	R53	QRD161J-331	CR
	R54	QRD161J-103	CR
	R55	QRD161J-103	CR
	R56	QRD161J-331	CR
	R57	QVZ3518-332	VR, L LEVEL
	R58	QRD161J-472	CR
	R59	QRD161J-103	CR
	R60	-	-
	R61	-	-
	R62	QVZ3518-332	VR, R LEVEL
	R63	QRD161J-472	CR
	R64	QRD161J-103	CR
	R65	-	-
	R66	QRD161J-821	CR
	R67	QRD161J-821	CR
	R73	QRD161J-224	CR
	R74	QRD161J-394	CR
	R75	QRD161J-103	CR
	R76	QRD161J-104	CR
	R77	-	-
	R78	QRD161J-820	CR
	R84	QRD161J-103	CR
	R85	-	-
	R86	QRD161J-101	CR
	C1	QCBB1HK-102	C CAP
	C2	QETC1CM-476	E CAP

▲ REF. NO. PART NO. PART NAME, DESCRIPTION

CN10 PU58844-102 CAP. HOUSING, E/EG
 CN11 PU58844-104 CAP. HOUSING, E/EG
 CN12 PU58844-102R CAP. HOUSING, E/EG
 PU58844-102 CAP. HOUSING, EK ONLY
 CN13 PU58844-106 CAP. HOUSING
 CN14 PU58844-103 CAP. HOUSING

▲ REF. NO. PART NO. PART NAME, DESCRIPTION

R24 QRD161J-472 CR
 R25 QRD161J-682 CR
 R26 QRD161J-472 CR
 R27 QRD161J-102 CR
 R28 QRD161J-103 CR
 R29 QRD161J-103 CR
 R30 QRD161J-184 CR
 R31 QRD161J-103 CR
 R32 QRD161J-332 CR
 R33 QRD161J-661 CR
 R34 QRD161J-474 CR
 R35 QRD161J-474 CR
 R36 QRD161J-332 CR
 R37 QRD161J-103 CR

.....
 PU36127B-1(E/EG) VPS BOARD ASS'Y (18)

▲ IC1 HD49703NT INTEGRATED CIRCUIT
 ▲ IC2 M5278L05 INTEGRATED CIRCUIT

Q1 2SB641R,S TRANSISTOR
 Q2 2SC3327A TRANSISTOR
 OR 2SC2878A TRANSISTOR
 Q3 2SD837R,S TRANSISTOR

D1 1SS133 DIODE
 D2 1SS133 DIODE
 D3 1SS133 DIODE
 D4 1SS133 DIODE
 D5 1SS133 DIODE

R1 QRD161J-103 CR
 R2 QRD161J-103 CR
 R3 QRD161J-102 CR
 R4 QRD161J-102 CR
 R5 QRD161J-102 CR
 R6 QRD161J-473 CR
 R7 QRD161J-103 CR
 R8 QRD161J-391 CR
 R9 QRD161J-662 CR
 R10 QRD161J-102 CR

R11 QRD161J-473 CR
 R12 QRD161J-662 CR
 R13 QRD161J-105 CR
 R14 QRD161J-472 CR
 R15 QRD161J-472 CR
 R16 QRD161J-472 CR
 R17 QRD161J-472 CR
 R18 QRD161J-662 CR
 R19 QRD161J-663 CR
 R20 QRD161J-222 CR

R21 QRD161J-222 CR
 R22 QRD161J-222 CR
 R23 QRD161J-222 CR

C1 QETC1CM-336 E CAP
 C2 QCS31HJ-681 C CAP
 C3 QETC1CM-106 E CAP
 C4 QCS31HJ-391 C CAP
 C5 QCT25CH-390 C CAP
 C6 QFN31HJ-103 MY CAP
 C7 QFN31HJ-102 MY CAP
 C8 QFN31HJ-102 MY CAP
 C9 QETC1CM-336 E CAP
 C10 QETC1CM-336 E CAP
 C11 QCF31HP-473 C CAP
 C12 QETC1CM-336 E CAP
 C13 QETC1CM-336 E CAP
 C14 QETC1CM-336 E CAP
 C15 QCS31HJ-391 C CAP
 C16 QETC1HM-335 E CAP
 C17 QETC1HM-105 E CAP
 C18 QETC1HM-106 E CAP
 C19 QCT25CH-390 C CAP
 C20 QCT25CH-150 C CAP
 C21 QETC1CM-336 E CAP
 C22 QCT25CH-100 C CAP

T1 PU58484 COIL, OSC, TIMING

RA1 RN8H5A224 RESISTOR NETWORK

CN1 PU58844-3 CAP. HOUSING
 CN2 PU58844-4 CAP. HOUSING

TP PU56008 TEST PIN, TP1-6

#	△	REF. NO.	PART NO.	PART NAME, DESCRIPTION
			PU22415B3-04(E/EG)	POWER TRANSISTOR BOARD ASS'Y [19]
			PU22415A3-04(EK)	POWER TRANSISTOR BOARD ASS'Y [19]
		Q1	2SD1740-01	TRANSISTOR
		Q2	2SD1740-01	TRANSISTOR
		Q3	-	-
		Q4	2SD1740-01	TRANSISTOR
	△	HTS1	PQ31378	HEAT SINK
		SCR1	DPSP3010Z	SCREW, X3, FOR Q1, Q2, Q4
			PU11473C1-02(E)	FRONT BOARD ASS'Y [21]
			PU11473B1-02(EG)	FRONT BOARD ASS'Y [21]
			PU11473A1-02(EK)	FRONT BOARD ASS'Y [21]
	△	IC1	UPD75208CW-030	INTEGRATED CIRCUIT
		IC2	UPD82C43CY	INTEGRATED CIRCUIT
		IC3	S-8053HLB	INTEGRATED CIRCUIT
	△	IC4	M5278L56	INTEGRATED CIRCUIT
		IC101	MSC1124BRS	INTEGRATED CIRCUIT
		IC201	LA7224	INTEGRATED CIRCUIT, E/EG
		IC201	LA7225	INTEGRATED CIRCUIT, EK
		Q1	DTC124ES	D. TRANSISTOR
		Q2	DTA114ES	D. TRANSISTOR
		Q3	DTC124ES	D. TRANSISTOR
		Q4	DTC124ES	D. TRANSISTOR
		Q5	DTC124ES	D. TRANSISTOR
		Q6	2SC1685R,S	TRANSISTOR
		Q7	-	-
		Q8	-	-
		Q9	-	-
		Q10	2SC1685R,S	TRANSISTOR
		Q11	2SC1685R,S	TRANSISTOR
		Q12	DTC124ES	D. TRANSISTOR
		D1	1SS132	DIODE
		D2	1SS132	DIODE
		D3	1SS132	DIODE
		D4	1SS132	DIODE
		D5	1SS132	DIODE
		D6	1SS132	DIODE
		D7	1SS132	DIODE

#	△	REF. NO.	PART NO.	PART NAME, DESCRIPTION
		D8	1SS132	DIODE
		D9	1SS132	DIODE
		D10	1SS132	DIODE
		D11	1SS132	DIODE
		D12	-	-
		D13	-	-
		D14	1SS132	DIODE
		D15	-	-
		D16	-	-
		D17	RD8.2E83	ZENER DIODE
		D18	RD9.1ES-T1B2	ZENER DIODE
		D19	1SS133	DIODE
		D20	1SS133	DIODE
		D21	1SS133	DIODE
		D22	1SS132	DIODE
		D23	1SS132	DIODE
		D24	1SS132	DIODE
		D25	RD7.5ES-T181	ZENER DIODE
	△	D101	HZ24-2L	ZENER DIODE
		D201	SLP-981C-50	LED, OPERATE
		D208	SLP-981C-50	LED, HI-FI STEREO
		D209	SLP-981C-50	LED, NORMAL
		D210	SLP-981C-50	LED, L-CH
		D211	SLP-981C-50	LED, R-CH
		D212	SLP-981C-50	LED, STEREO, E/EG
		D213	SLP-981C-50	LED, BILINGUAL, E/EG
		D214	-	-
		D215	SLP-981C-50	LED, SC
		D216	-	-
		D217	-	-
		D218	-	-
		D219	-	-
		D220	PD49PI	PIN PHOTO DIODE
		D221	1SS133	DIODE
		D222	1SS133	DIODE
		R1	QRD161J-472	CR
		R2	QRD161J-472	CR
		R3	QRD161J-472	CR
		R4	QRD161J-472	CR
		R5	QRD161J-334	CR
		R6	QRD161J-682	CR
		R14	QRD161J-333	CR
		R15	QRD161J-333	CR
		R16	QRD161J-273	CR
		R17	QRD161J-472	CR
		R18	QRD161J-471	CR
		R19	QRD161J-103	CR
		R20	QRD161J-103	CR
		R21	QRD161J-103	CR

