

SERVICE MANUAL

PARTS LIST

MODEL GXC-760D

AKAI

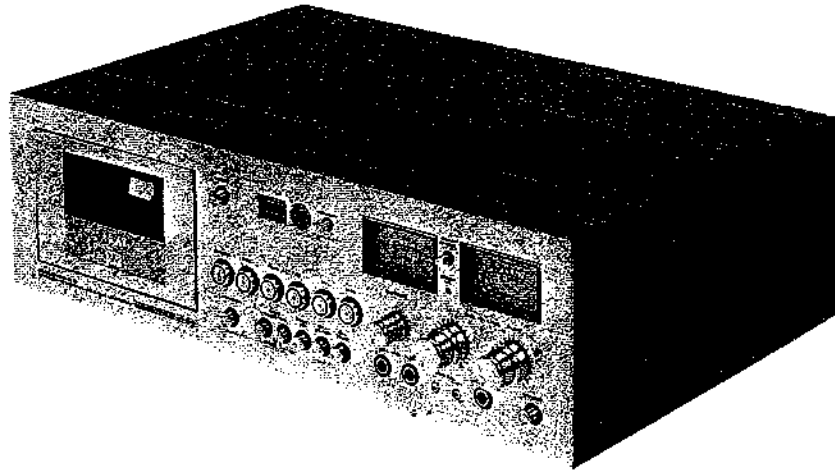

**CASSETTE STEREO
TAPE DECK**

MODEL GXC-760D

SECTION 1	SERVICE MANUAL	1
SECTION 2	PARTS LIST	31
SECTION 3	SCHEMATIC DIAGRAM	52

SECTION 1

SERVICE MANUAL

TABLE OF CONTENTS

I.	TECHNICAL DATA	2
II.	DISMANTLING OF UNIT	3
III.	ARRANGEMENT OF PRINCIPAL PARTS	4
IV.	SYSTEM CONTROL OPERATING PRINCIPLES	5
	1. TAPE SLACK ELIMINATION CIRCUIT	7
	2. PINCH ROLLER OPERATION AND REEL MOTOR ROTATION TIMING CIRCUIT	7
	3. FAST FORWARD AND REWIND SPEED CONTROL CIRCUIT	8
	4. MAGNETIC BRAKING CIRCUIT	8
	5. AUTOMATIC SHUT-OFF MECHANISM CIRCUIT	8
V.	MECHANISM ADJUSTMENT	9
	1. CAPSTAN SHAFT LOOSE PLAY ADJUSTMENT	9
	2. MOTOR PULLEY INSTALLATION POSITION ADJUSTMENT	9
	3. REEL TABLE INSTALLATION POSITION ADJUSTMENT	9
	4. PLAY SOLENOID INSTALLATION POSITION ADJUSTMENT	10
	5. PINCH ROLLER PRESSURE ADJUSTMENT	10
	6. ADJUSTMENT OF EJECT MICRO SWITCH ACTUATING POSITION	11
	7. ADJUSTMENT OF RECORDING MICRO SWITCH (SW1) AND CASSETTE MICRO SWITCH (SW2) ACTUATING POSITION .	11
	8. CLEARANCE ADJUSTMENT BETWEEN HALL IC AND ROTARY MAGNET	12
	9. POSITION ADJUSTMENT OF LID CASE	12
	10. REEL MOTOR REPLACEMENT	13
	11. TAPE SPEED ADJUSTMENT	13
VI.	HEAD ADJUSTMENT	14
	1. TAPE GUIDE HEIGHT ADJUSTMENT	14
	2. HEIGHT ADJUSTMENT OF RECORDING/PLAYBACK COMBINATION HEAD	14
	3. AZIMUTH ALIGNMENT ADJUSTMENT OF RECORDING/PLAYBACK COMBINATION HEAD	14
VII.	AMPLIFIER ADJUSTMENT	15
	1. RECORDING/PLAYBACK AMPLIFIER ADJUSTMENT	17
	2. DOLBY NOISE REDUCTION CIRCUIT ADJUSTMENT	18
VIII.	DC RESISTANCE OF VARIOUS COILS	19
IX.	CLASSIFICATION OF VARIOUS P.C BOARDS	19
	1. RELATION OF P.C BOARD TITLE AND NUMBER	19
	2. COMPOSITION OF VARIOUS P.C BOARDS	20

For basic adjustments, measuring methods, and operating principles, refer to GENERAL OPERATING PRINCIPLES AND ADJUSTMENTS.

I. TECHNICAL DATA

TRACK SYSTEM	4 track 2 channel stereo system
TAPE	Philips type cassette
TAPE SPEED	1-7/8 ips
WOW AND FLUTTER	Less than 0.06% WRMS Less than 0.17% (DIN 45500)
FREQUENCY RESPONSE	30 Hz to 15,000 Hz (± 3 dB) using low noise tape 30 Hz to 16,000 Hz (± 3 dB) using CrO ₂ tape 30 Hz to 19,000 Hz (± 3 dB) using Fe-Cr tape
DISTORTION	Less than 1% (1,000 Hz "0" VU) using low noise tape
SIGNAL TO NOISE RATIO	Better than 51 dB (measured via tape with peak recording of +5 VU) Dolby Switch ON: Improves up to 10 dB above 5 kHz
ERASE RATIO	Better than 70 dB
BIAS FREQUENCY	100 kHz
HEADS	GX recording/playback head and erase head (3 head system)
MOTOR	One AC Servo outer-rotor motor for capstan drive, and two DC motor for reel drive
FAST FORWARD AND REWIND TIME	70 seconds using C-60 cassette tape
OUTPUT JACKS	Line (2): 0.775V ("0" VU) Required load impedance: More than 20 k ohms Phones (1): 50 mV/8 ohms
INPUT JACKS	Microphone (2): 0.3 mV Required microphone impedance: 600 ohms Line (2): 70 mV/100 k ohms
TRANSISTOR	2SA628(E) (F) 2 2SB605(K) (L) 2 2SC458LG(C) 8 2SC945L(P) 2 2SC945L(Q) (R) 47 2SC1175(E) (F) 2 2SC1211(E) (F) 1 2SC1222(E) (F) 4 2SC1647(S) (E) 6 2SC1683(P) (Q) 1 2SD360(D) (E) 1 2SD361(D) (E) 2 2SD401(K) (L) 1 2SD571(K) (L) 4
FET	2SK30A(D) 4 2SK68A(L) (M) 2
DIODE	1N34A 4 1S2473 45 1S2473VE 67 10D05 4 10D4 5 WZ085 2 WZ240 2
POWER REQUIREMENTS	CSA, UL and LA Models: 120V, 60 Hz only CEE Models: 220V, 50 Hz only Other Models: 100 to 240V, 50/60 Hz (Switchable)
DIMENSIONS	440(W) x 142(H) x 306(D)mm (17.3 x 5.6 x 12.0) inches
WEIGHT	11.1 kg (24.4 lbs)

- NOTES: 1. For improvement purposes, specifications and design are subject to change without notice.
2. Dolby is a trademark of Dolby Laboratories, Inc. Under License from Dolby Laboratories, Inc.
The word 'DOLBY' and the Double-D symbol are trademarks of Dolby Laboratories Inc.

II. DISMANTLING OF UNIT

In case of trouble, etc. necessitating disassembly, please disassemble in the order shown in photographs. Reassemble in reverse order.

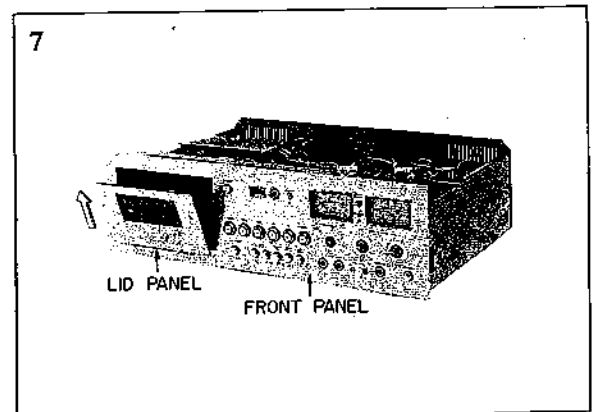
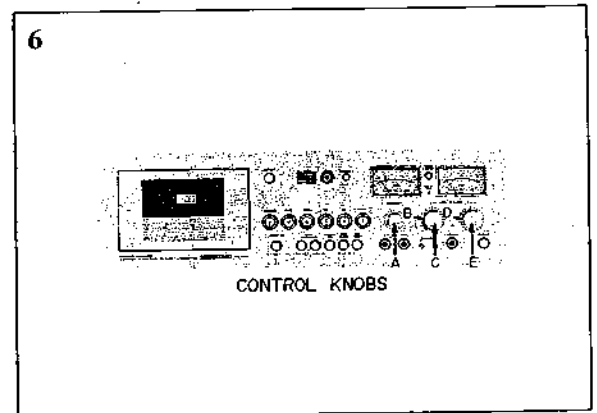
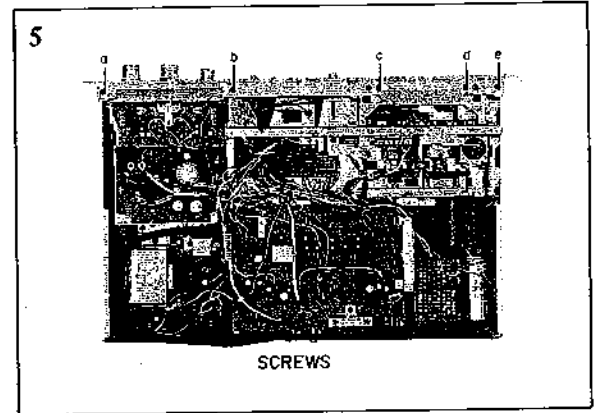
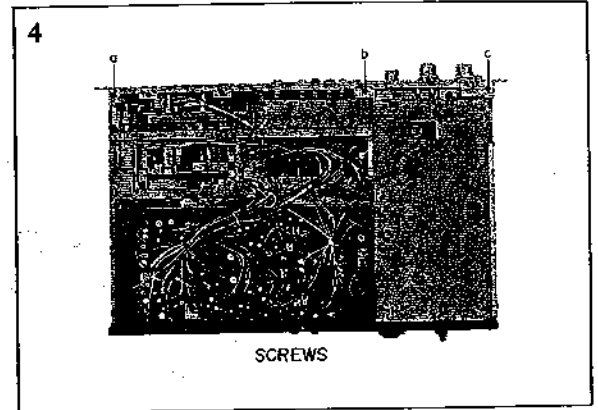
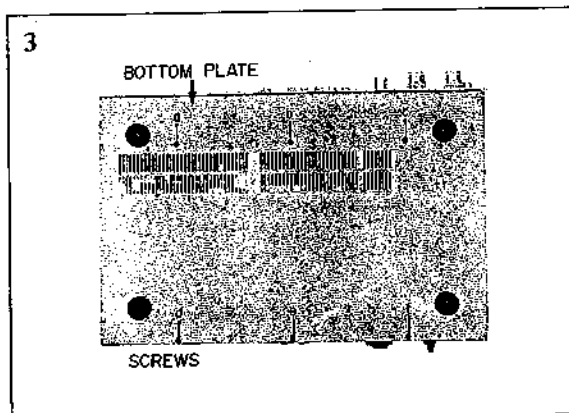
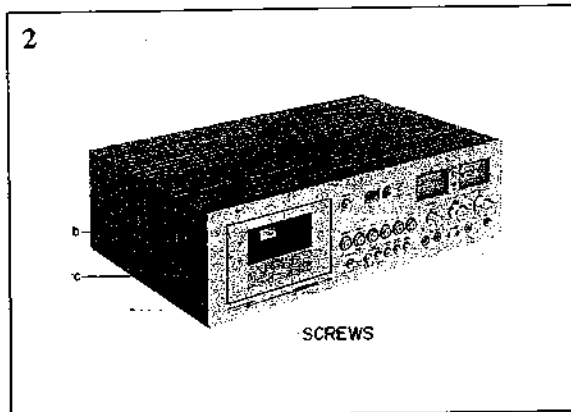
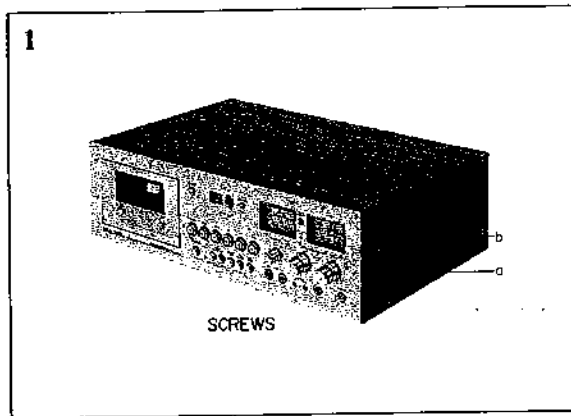

III. ARRANGEMENT OF PRINCIPAL PARTS

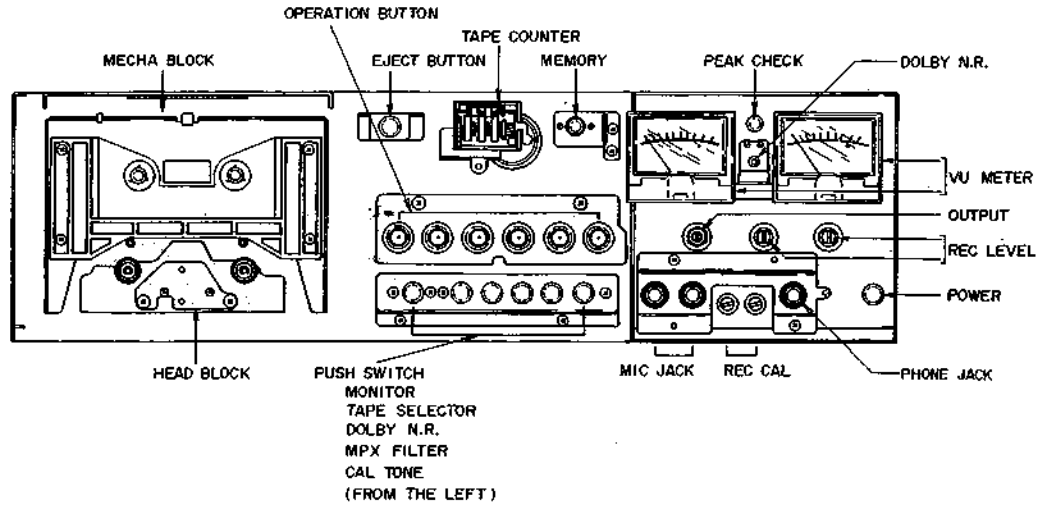

Fig. 1 Front View

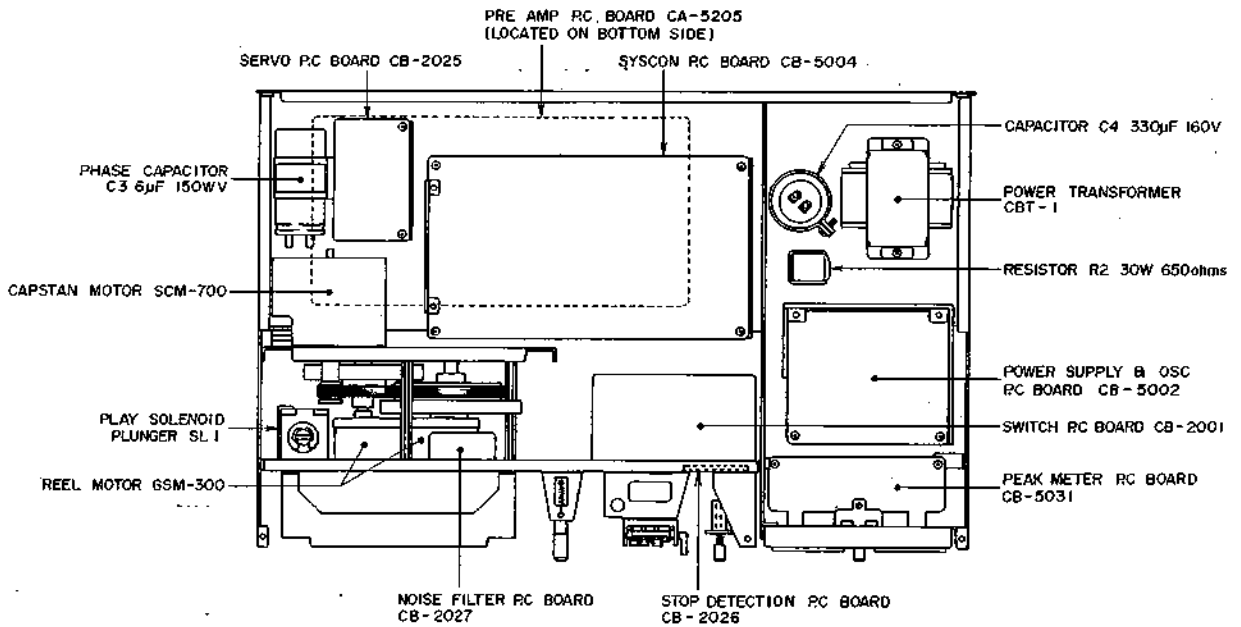
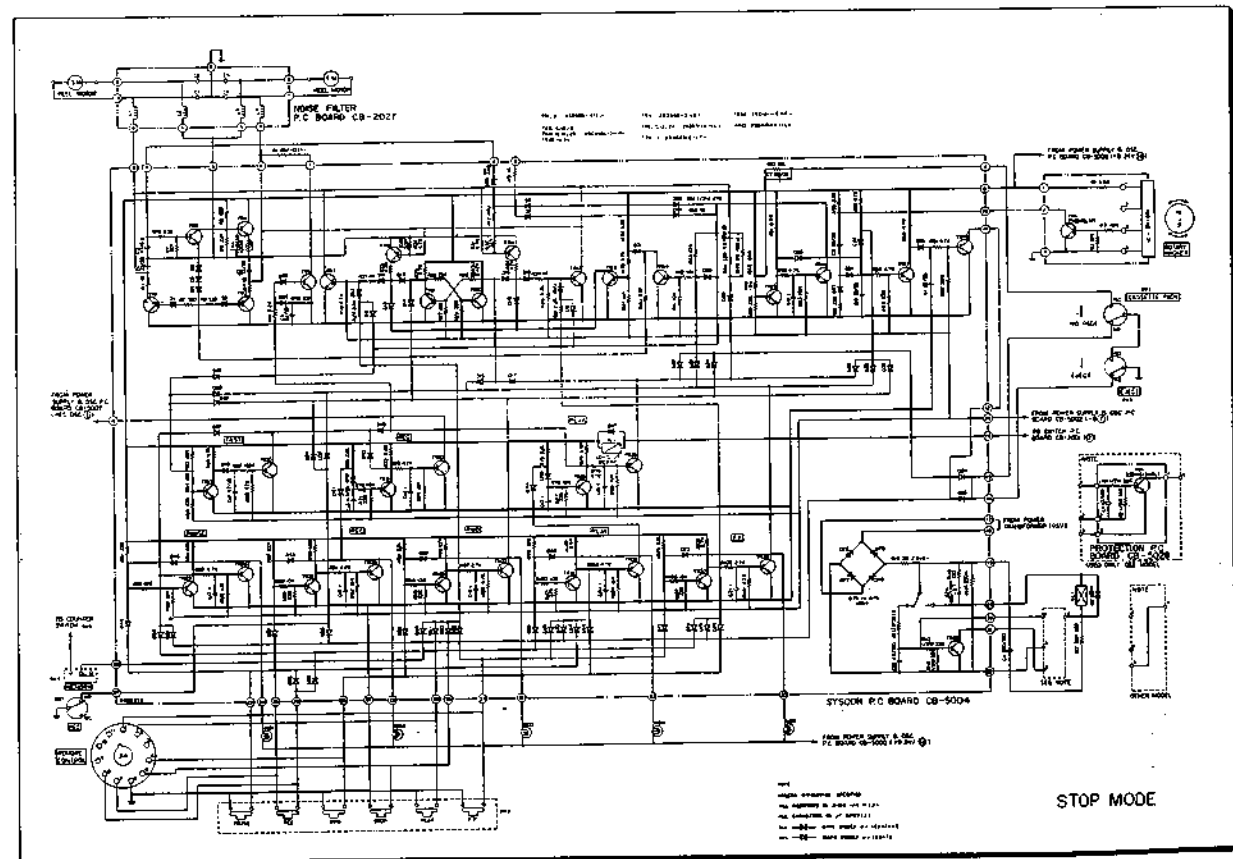
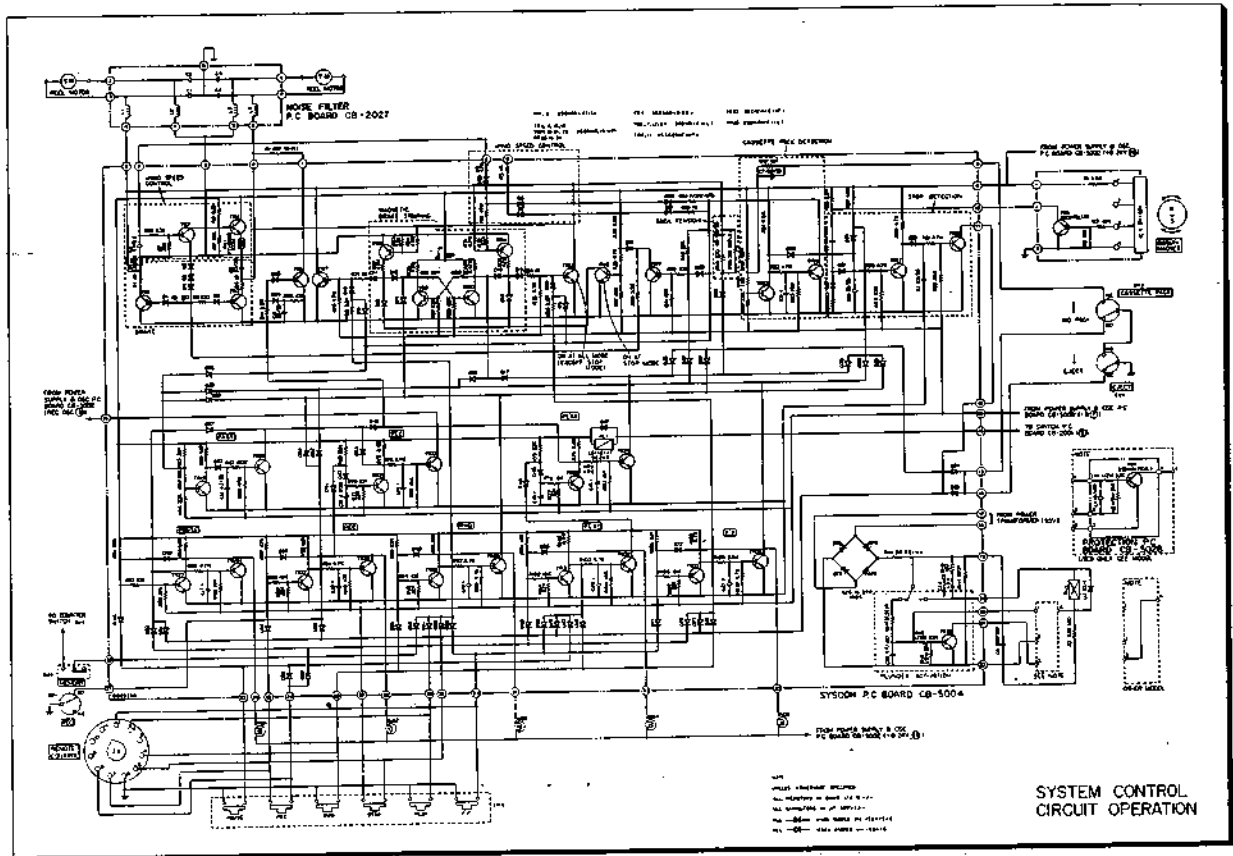
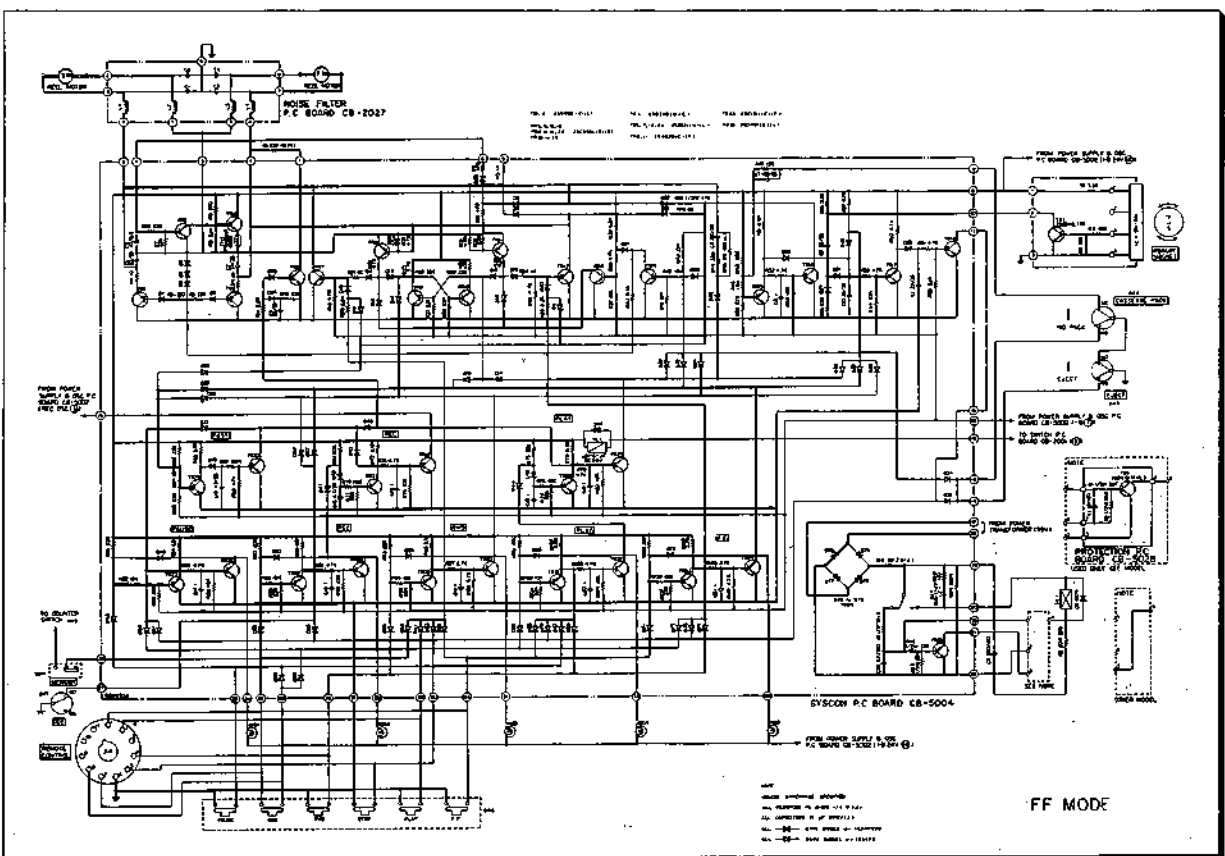
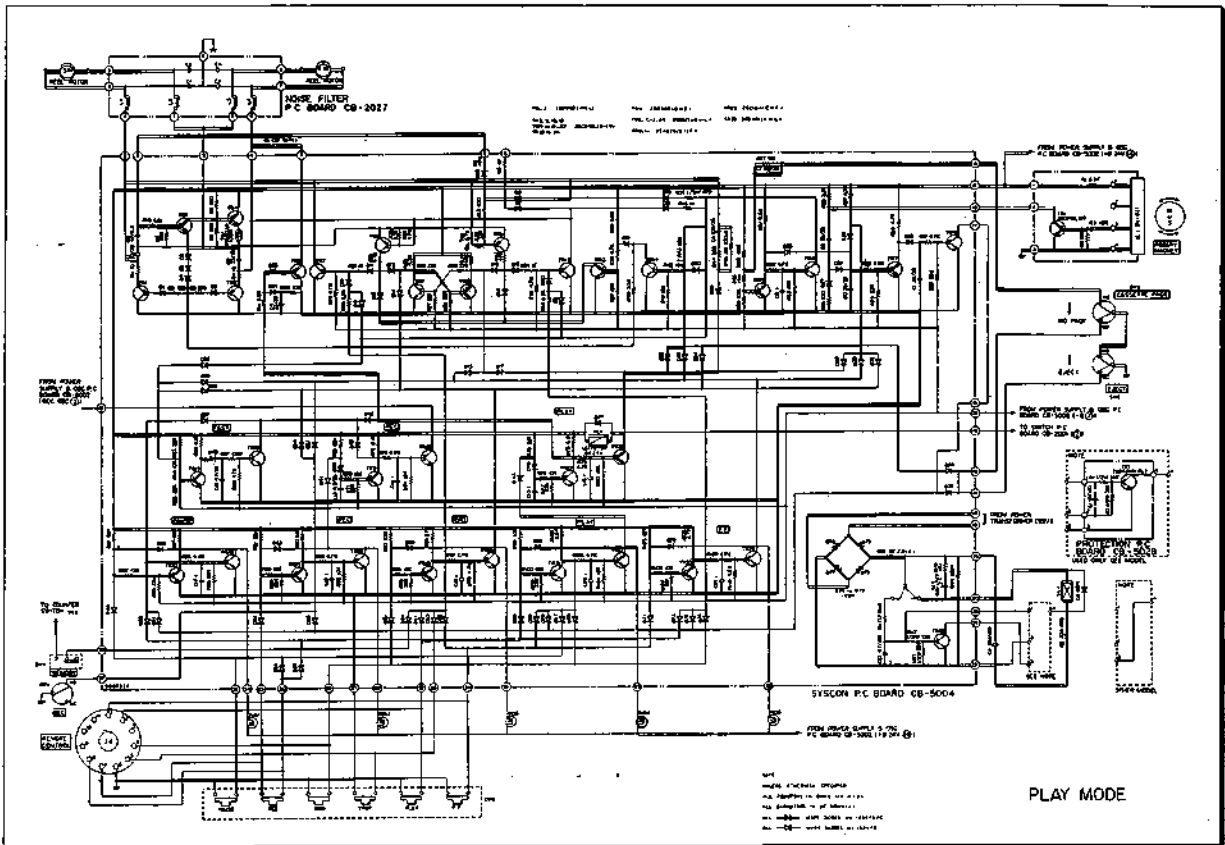
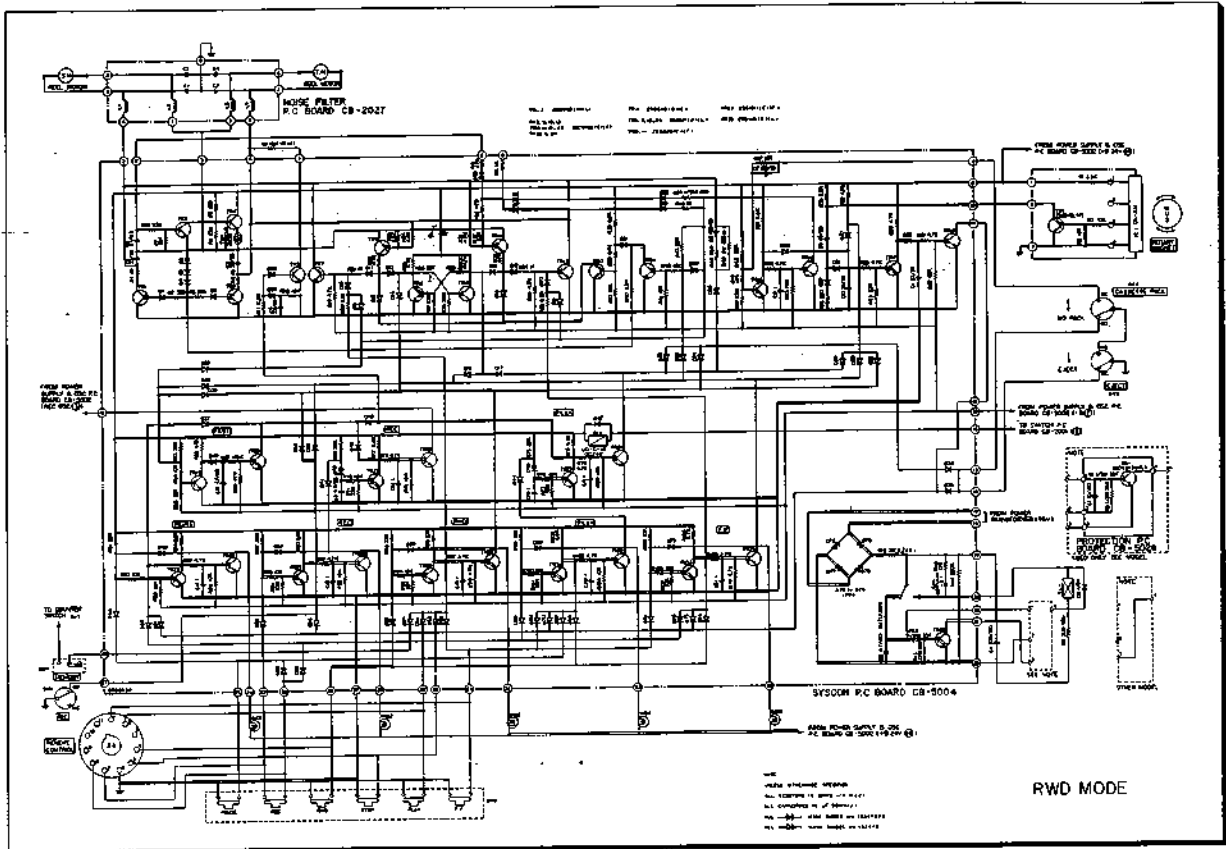

Fig. 2 Top View

IV. SYSTEM CONTROL OPERATING PRINCIPLES







1. TAPE SLACK ELIMINATION CIRCUIT

- 1) Because this deck employs a double capstan drive system, if tape with a great deal of slack is used, trouble with the tape tangling around the capstan is likely to occur. Even if only slight tape slack exists, it takes time after effecting a forward mode to obtain proper tape tension, which results in a continuous poor head-to-tape contact condition. The purpose of this circuit is to prevent such trouble by taking up tape slack prior to operation for proper tape tension at all times.
- 2) When a cassette is not loaded, TR15 assumes an ON condition and TR16 an OFF condition. When a cassette is loaded, cassette detection micro switch SW2 contacts NC side (contact point), and a charge current flows to C7. Within this charge current period, TR15 is turned OFF and collector voltage increases. Charge current flows to R52 and C8 and at the end of the charge current period, TR16 is turned ON and collector current flows. This current passes D81, causing the take-up motor to rotate, and at the same time passes D82, causing the supply motor to rotate. Thus, the tape is pulled from both directions, and any existing slack is eliminated. This process continues until the C7 charge current ends, at which time the circuit returns to its previous state, stopping both reel motors.

2. PINCH ROLLER OPERATION AND REEL MOTOR ROTATION TIMING CIRCUIT

- 1) If reel motor starts to rotate before the pinch roller reaches the capstan, momentary brake tension will be applied, causing the tape to break or stretch. This circuit is for the purpose of eliminating such trouble by activating reel motor revolutions after the pinch roller has contacted the capstan when playback mode is effected.
- 2) When the deck is set to Play mode, TR23 collector voltage is increased, TR24 is turned ON, the relay functions, and the pinch roller plunger operates. At the same time, as a result of an increase in TR23 collector voltage, charge current passes R11 and D84 and flows to C4. During the period of this flow of charge current, TR5 base voltage is lowered, and because TR5 is turned OFF, the take-up motor does not rotate. However, at the end of this flow of charge current, TR5 base voltage increases, TR5 is turned ON, and motor starts to rotate.
The period of time until TR5 is turned ON is about 0.1 to 0.2 seconds.

3. FAST FORWARD AND REWIND SPEED CONTROL CIRCUIT

1) The reel motors employed in this deck are DC motors which at a non-load condition rotates at about 3,000 rpm. Consequently, when Fast Forward or Rewind is effected, there is a possibility of tape damage due to a gradual build-up of inertia and increased revolutions. This circuit is for the purpose of controlling supply voltage to the take-up reel motor for suppression of increased motor revolutions.

2) When the deck is set to Fast Forward mode, TR12 is turned ON and the take-up motor begins to rotate. When the supply reel motor is not rotating, because bias is not supplied to the base of TR3, the resistance between TR3 collector and emitter is infinite, and a fixed bias is supplied to TR4 through R8 and R9, a fixed DC voltage is supplied to the take-up reel motor, and there is a build-up of inertia and gradual increase in motor revolutions.

However, at Fast Forward Mode, the supply reel motor of this deck functions as a generator. Consequently, the electromotive force generated by the supply reel motor passes D6, D85, R6 and R119 and becomes TR3 base bias, and the resistance between TR3 collector and emitter is varied proportionately according to the extent of the generator's electromotive force.

That is to say, R9 and the resistance between TR3 collector and emitter becomes parallel composite resistance and bias to TR4 is varied by this composite resistance. Momentarily, when the take-up reel motor begins to rotate at high speed, this counterbalanced electromotive force is generated by the supply reel motor and this generated voltage increases the resistance between TR4 collector and emitter and the supply voltage to the take-up reel motor is decreased. Thus, motor revolutions are slowed for a decrease in speed. In this manner, the take-up speed always corresponds with the supply reel motor speed, thus avoiding high speed motor revolutions.

3) Speed control also functions in exactly the same way at Rewind mode. However, in this case, the right hand side reel motor functions as a generator, and left hand side reel motor revolutions are controlled by means of supply voltage control. Therefore, Rewind speed is controlled in the same way as at Fast Forward.

4. MAGNETIC BRAKING CIRCUIT

1) This deck differs from other 3 motor system decks to date in that instead of a mechanical braking system, tape travel is stopped electrically, and a magnetic braking system is employed. When Fast Forward or Rewind is being effected, the take-up motor rotates while being controlled by the rotation of the supply side motor.

This circuit is for the purpose of applying magnetic braking to the proper motor when stop mode

is being effected from Fast Forward or Rewind.

2) At Fast Forward, TR12 is turned ON and the take-up motor rotates. The supply side motor rotates and functions as a generator to maintain proper take-up motor revolutions. At this time, the magnetic braking circuit maintains TR8 and TR10 at ON, and TR9 and TR11 at OFF condition. D12 is grounded through D13 and D12 anode becomes identical to grounding electrical potential. Consequently, TR7 assumes an OFF condition. (In other words, current does not flow to the supply side motor).

3) When the deck is stopped from Fast Forward mode, TR12 is turned OFF, and the current to the take-up motor ceases. Also TR14 is turned ON and TR13 turned OFF, and at the same time, D1 anode assumes a floating condition. Current flows by means of the electromotive force from the take-up side motor, and this current turns ON TR7 and voltage is supplied to the supply side motor. This voltage becomes the braking voltage of the supply side motor.

4) When magnetic braking is first applied, because the take-up motor is rotating fairly fast, a large electromotive force is generated, TR17 is turned completely ON, and maximum voltage is supplied to the supply side motor. Thus, speed is reduced and at the same time, this voltage is decreased. Also the take-up motor electromotive force disappears, and at the same time, the supply side motor rotation stops.

5) When the deck is stopped from Fast Forward mode, the operation is the same as described above. Only the circuit components differ.

5. AUTOMATIC SHUT-OFF MECHANISM CIRCUIT

1) This circuit is for the purpose of effecting automatic shut-off when tape travel has stopped after play, recording, fast forward, or rewind mode.

2) During tape travel, because the rotary magnet rotates, Stop Detection circuit TR1 performs the ON ↔ OFF switching operation. Also during tape travel, because D30 anode becomes grounding electrical potential, TR17 is turned OFF. However, charge and discharge current alternately flows to C9 by means of the Stop Detection circuit. At charging time, current flows to R55 → C9 → D31 → C10, and TR17 is turned ON. At discharging time, current flows to R56 → D27 → C9 → TR1 (stop detection circuit). During this time, C10 discharge current passes R58 and TR17 is maintained at ON condition. When tape travel has stopped, C9 charge and discharge current will not flow, C10 discharge current also ends, and TR17 is turned OFF. Then TR18 is turned ON, and the diode connected to TR18 collector for instance, if automatic shut off is effected from play mode, D70 is grounded, play circuit TR32 is turned OFF, and Shut-off mode is effected.

V. MECHANISM ADJUSTMENT

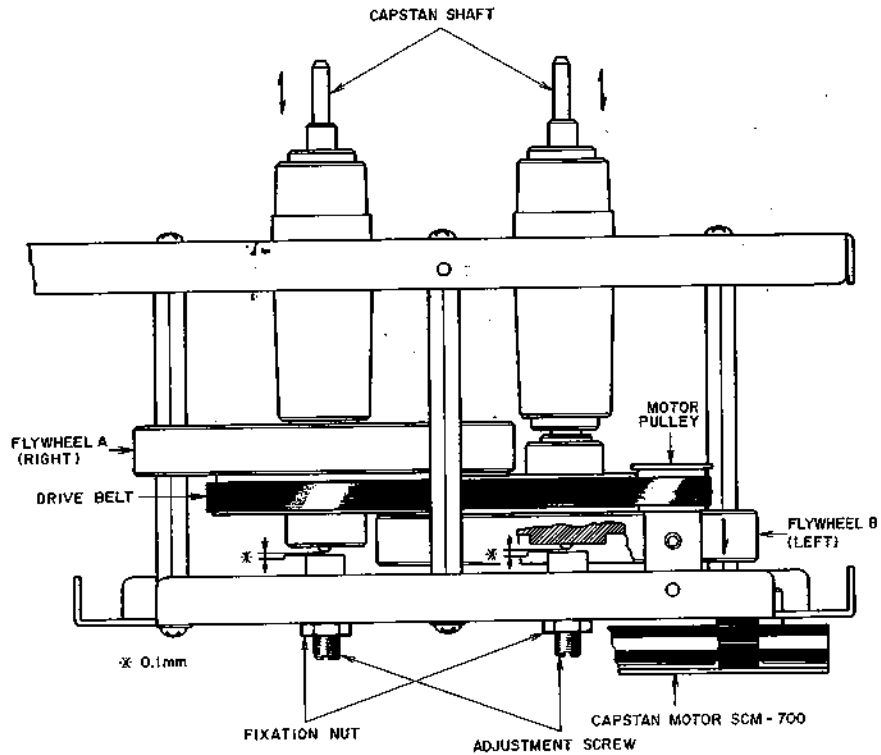

Fig. 3

1. CAPSTAN SHAFT LOOSE PLAY ADJUSTMENT (Refer to Fig. 3)

Adjust by turning adjustment screws to obtain a 0.1 mm degree of loose play (space indicated by * mark in figure) when the capstan shaft is moved as indicated by the arrow mark. Tighten fixation nut to maintain optimum adjusted condition.

NOTE: This deck employs 2 kinds of Flywheels
 Flywheel A Take up side
 Flywheel B Supply side

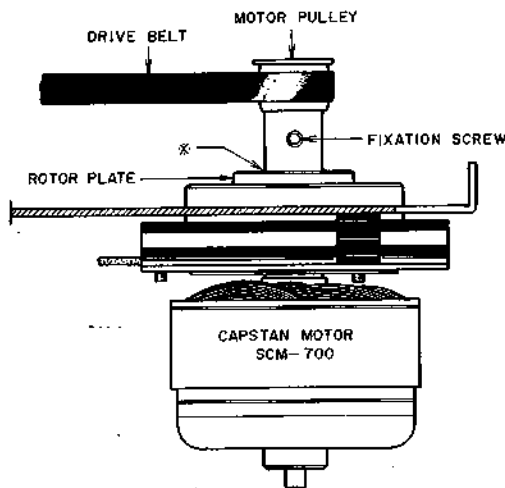

Fig. 4

2. MOTOR PULLEY INSTALLATION POSITION ADJUSTMENT (Refer to Fig. 4)

Tighten fixation screw at position at which the parts indicated by the * mark in the figure makes contact with the rotor plate.

NOTE: After above adjustment, in case the drive belt does not run on the center of Motor Pulley, re-adjust installation position of Motor Pulley so that the drive belt comes to the center of the Pulley. (Refer to Fig. 4)

3. REEL TABLE INSTALLATION POSITION ADJUSTMENT (Refer to Fig. 5)

As shown in Fig. 5, with reel table firmly and completely fitted on motor shaft, tighten fixation screw.

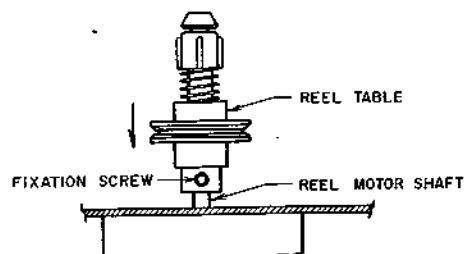

Fig. 5

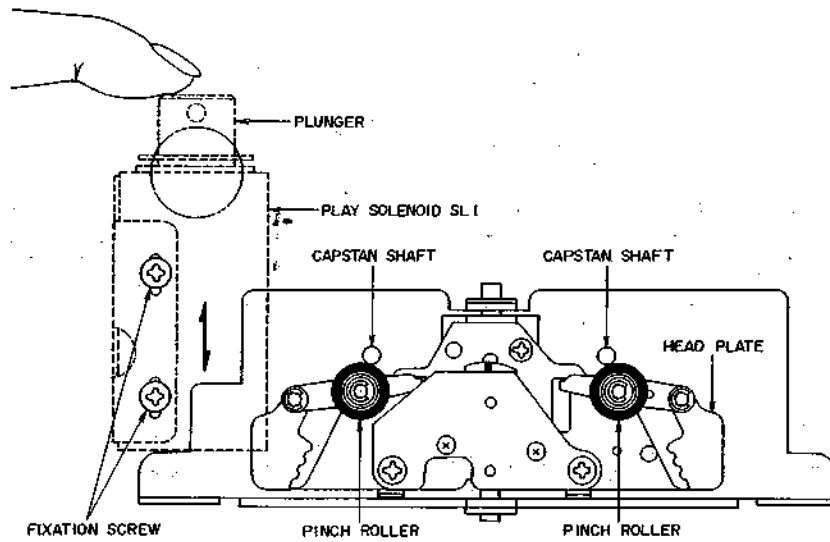

Fig. 6

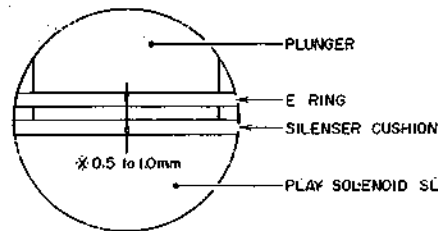

Fig. 7

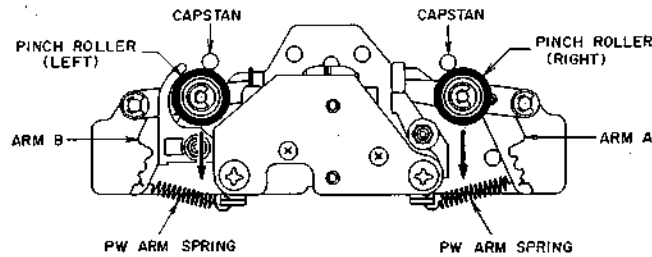

Fig. 8

4. PLAY SOLENOID INSTALLATION POSITION ADJUSTMENT (Refer to Fig. 6 and 7)

As shown in Fig. 6, at stop mode, when the tip of plunger is gently depressed, the pinch roller contacts the capstan shaft, at this time confirm that the gap between "E" ring and silencer cushion is 0.5 to 1.0 mm (See Fig. 7).

If not, adjust play solenoid installation position as indicated by the arrow mark in Fig. 6 to obtain specified gap.

5. PINCH ROLLER PRESSURE

ADJUSTMENT (Refer to Fig. 8)

Pull back the Pinch Roller with a spring gauge, and then return. Take a reading of the spring gauge scale indication at the moment the Pinch Roller touches the capstan and begins to rotate. Adjust pressure to specified value by changing position of the PW ARM SPRING.

Specified Pinch Roller Pressure:

Pinch Roller (right) 400 ± 50 gam
Pinch Roller (left) 300 ± 50 grm

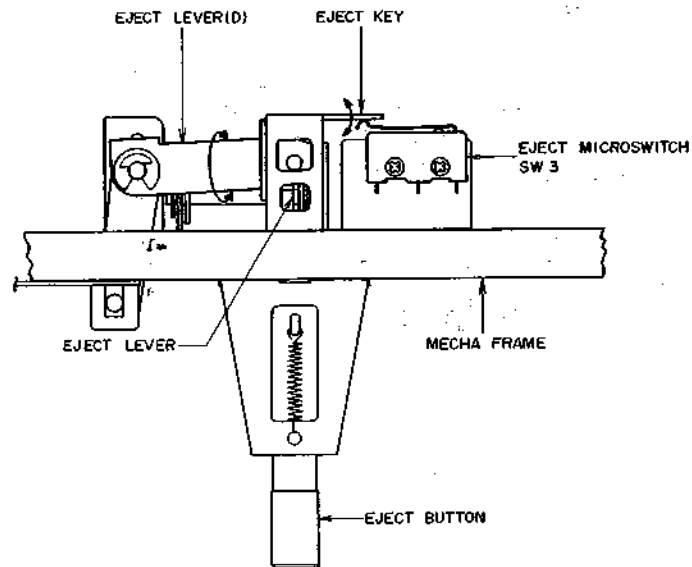

Fig. 9

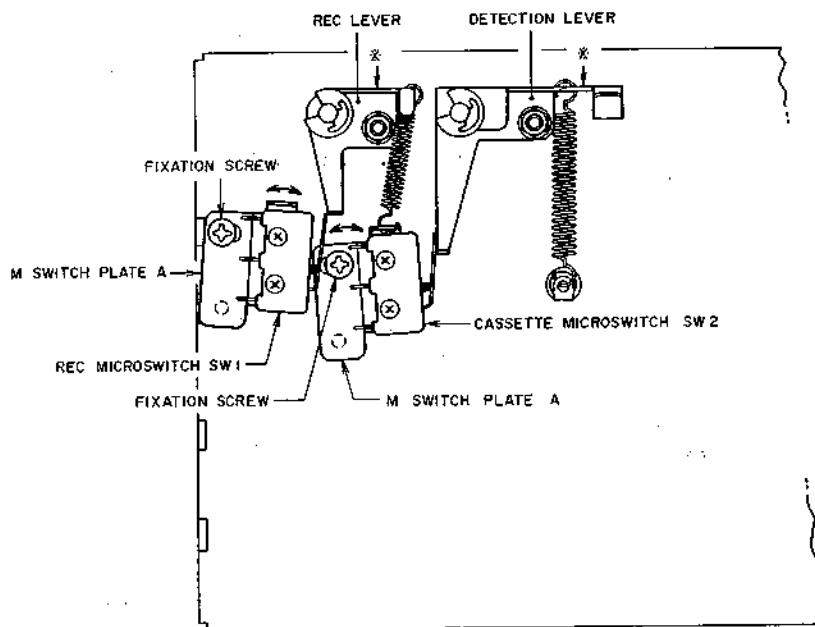

Fig. 10

6. ADJUSTMENT OF EJECT MICRO SWITCH ACTUATING POSITION (Refer to Fig. 9)

Adjust by bending Eject Key so that when the Eject Key is depressed, Eject Micro Switch (SW3) shown in Fig. 9 is perfectly actuated.

After adjustment, depress Eject Button and confirm that Eject Micro Switch (SW3) switches before the Eject Lever operates.

7. ADJUSTMENT OF RECORDING MICRO SWITCH (SW1) AND CASSETTE MICRO SWITCH (SW2)

ACTUATING POSITION (Refer to Fig. 10)
Move M Switch Plate A as indicated by the arrow marks in the figure and adjust so that when the parts of Recording and Detection Levers marked with * mark in Fig. 10 are at a horizontal level, Recording Micro Switch (SW1) and Cassette Micro Switch (SW2) are turned ON respectively. Further, confirm that when a cassette from which the recording safety tabs have been removed is loaded, Recording Micro Switch (SW1) switches, and when the cassette is removed, Cassette Micro Switch (SW2) switches. Tighten fixation screws to maintain ideally adjusted positions of M Switch Plates A.

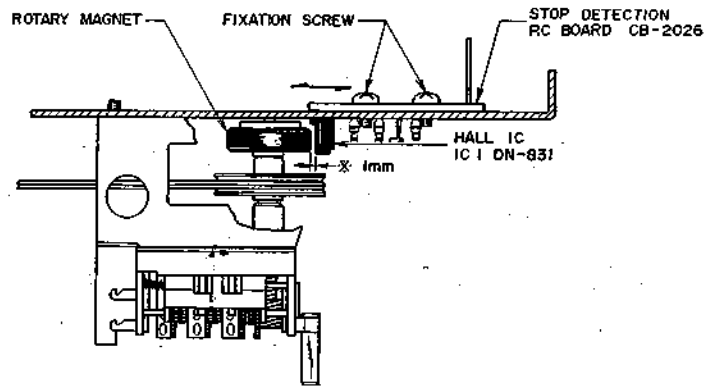

Fig. 11

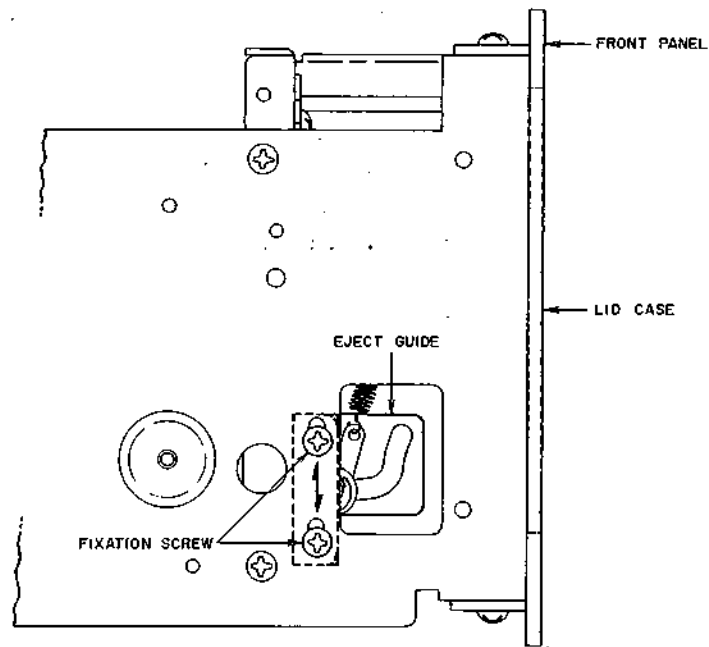

Fig. 12 Left Side of The Deck

8. CLEARANCE ADJUSTMENT BETWEEN HALL IC AND ROTARY MAGNET

(Refer to Fig. 11)

This adjustment is necessary for the perfection of the Automatic Stop Function. If adjustment is necessary due to poor Automatic Stop Function or instability, proceed as follows:

- 1) As shown in Fig. 11 move Stop Detection P.C Board as indicated by the arrow mark in the figure, and adjust position so that the clearance between the Hall IC and rotary magnet is 1 mm.
- 2) In case this clearance is over 1 mm, faulty Automatic Stop Function will occur.

9. POSITION ADJUSTMENT OF LID CASE

(Refer to Fig. 12)

Move the Eject Guide shown in Fig. 12 (direction indicated by arrow mark) up and down and adjust Lid case so that it is even with the front panel.

If the upper part of Lid case comes too far inward, raise the eject guide, and if too far outward, lower eject guide.

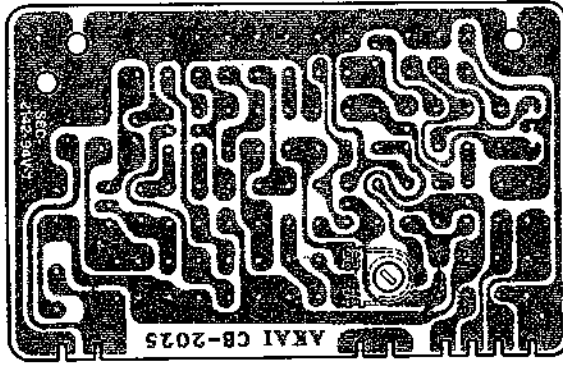

Fig. 13 Servo P.C Board CB-2025

10. REEL MOTOR (GSM-300)

REPLACEMENT

While the reel motors of this Deck are basically the same, because left and right characteristics differ, check as described below prior to replacement.

Supply reel motor: marked with L on thrust cap

Take-up reel motor: no marking

NOTE: If same type motor is not used, brush noise will occur.

11. TAPE SPEED ADJUSTMENT

(Refer to Fig. 13)

Playback a 1,000 Hz pre-recorded test tape and adjust Servo P.C Board (CB-2025) semi-fixed resistor VR1, 3 k Ω shown in Fig. 13 to obtain a tape speed of 1,000 Hz \pm 0.5%.

12) Tape Speed Adjustment (Refer to Fig. 10)

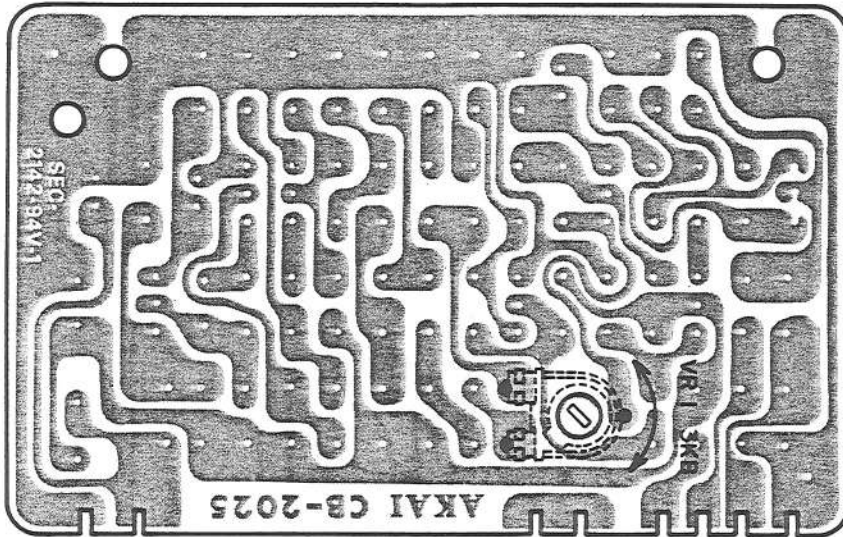

Fig - 10 SERVO P.C BOARD CB-2025

Playback a 1,000 Hz pre-recorded test tape and adjust Servo-Control P.C Board (CB-2025) semi-fixed resistor VR1, 3 k Ω shown in Fig. 10 to obtain a tape speed of 1,000 Hz $\pm 2\%$.

VI. HEAD ADJUSTMENT

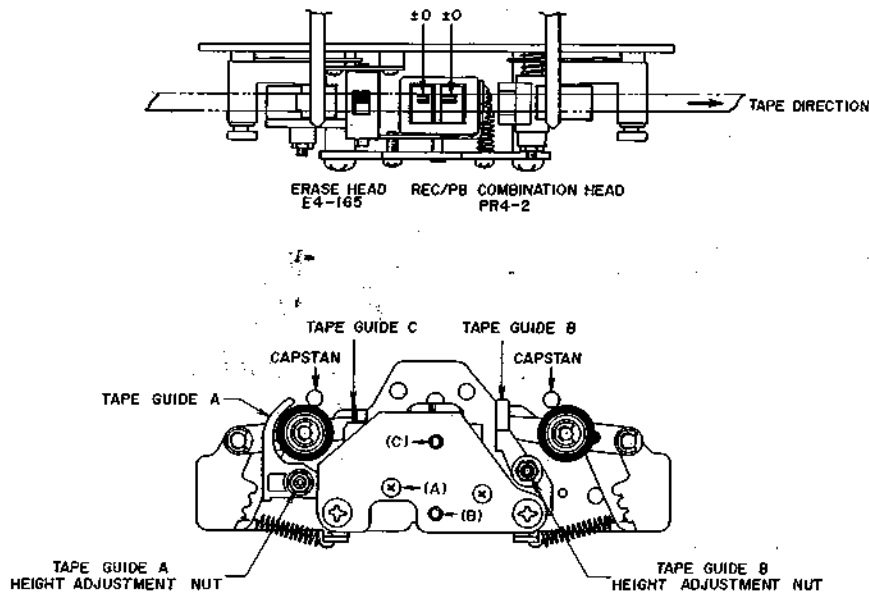

Fig. 14

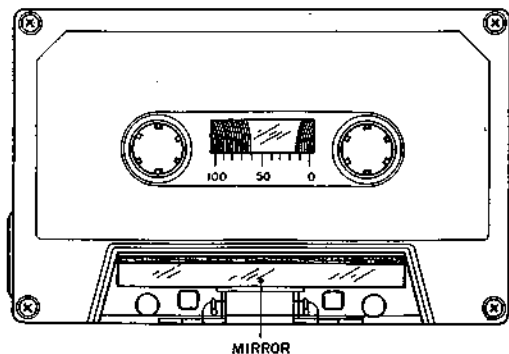

Fig. 15

1. TAPE GUIDE HEIGHT ADJUSTMENT

(Refer to Fig. 14 and Fig. 15)

- 1) When using an ordinary cassette, the tape guides and heads, etc. are not visible. As shown in Fig. 15, use a cassette tape from which part of the cassette case has been cut out and a mirror installed for easy visibility of the head area when making tape guide height adjustment.
- 2) At playback mode, using the erase head guide C shown in Fig. 14 as standard for height, adjust tape guide A and tape guide B height with tape guide height adjustment nuts so that the tape runs smoothly and does not catch on the tape guides.

2. HEIGHT ADJUSTMENT OF RECORDING/PLAYBACK COMBINATION HEAD

(Refer to Fig. 14)

- 1) Utilize the cassette tape used in Tape Guide Height Adjustment above, and playback the leader tape part of cassette tape.
- 2) As shown in Fig. 14, adjust head height with screws (A), (B), and (C) until the upper edge of the tape is the same height as the upper edge of the left channel REC/PB Comb. head core.

3. AZIMUTH ALIGNMENT ADJUSTMENT OF RECORDING/PLAYBACK COMBINATION HEAD (Refer to Fig. 14)

COMBINATION HEAD (Refer to Fig. 14)

- 1) Playback a 10 kHz pre-recorded cassette azimuth alignment test tape and adjust screw (A) shown in Fig. 14 to obtain maximum output on both channels.
- 2) Invert cassette and confirm that the output level does not change from that obtained in Item 3-1). above. If the output level differs, adjust in the same way as in Item 3-1). above until both sides of the test tape display equal output.
- 3) Supply a 10 kHz signal from an audio frequency oscillator to the line inputs and record at -20 VU on a blank tape.
- 4) Set Monitor Switch to "TAPE" position and adjust screw (A) shown in Fig. 14 to obtain maximum output on both left and right channels.
- 5) The recording and playback heads are joined to form a single structure. Therefore, when making azimuth alignment adjustments, because both head cores (recording and playback) move, repeat adjustments outlined in Items 3-1). through 3-4). above until optimum azimuth alignment of the two head cores are obtained.

NOTES: 1. Be sure to clean the heads prior to head adjustment.

2. Be careful not to use a magnetized driver or other magnetized tools in the vicinity of the heads.

3. Be sure to demagnetize the heads with a Head Demagnetizer before and after head adjustment.

4. When a mirror installed cassette test tape as shown in Fig. 15 is required, it can be ordered from AKAI Electric Co.

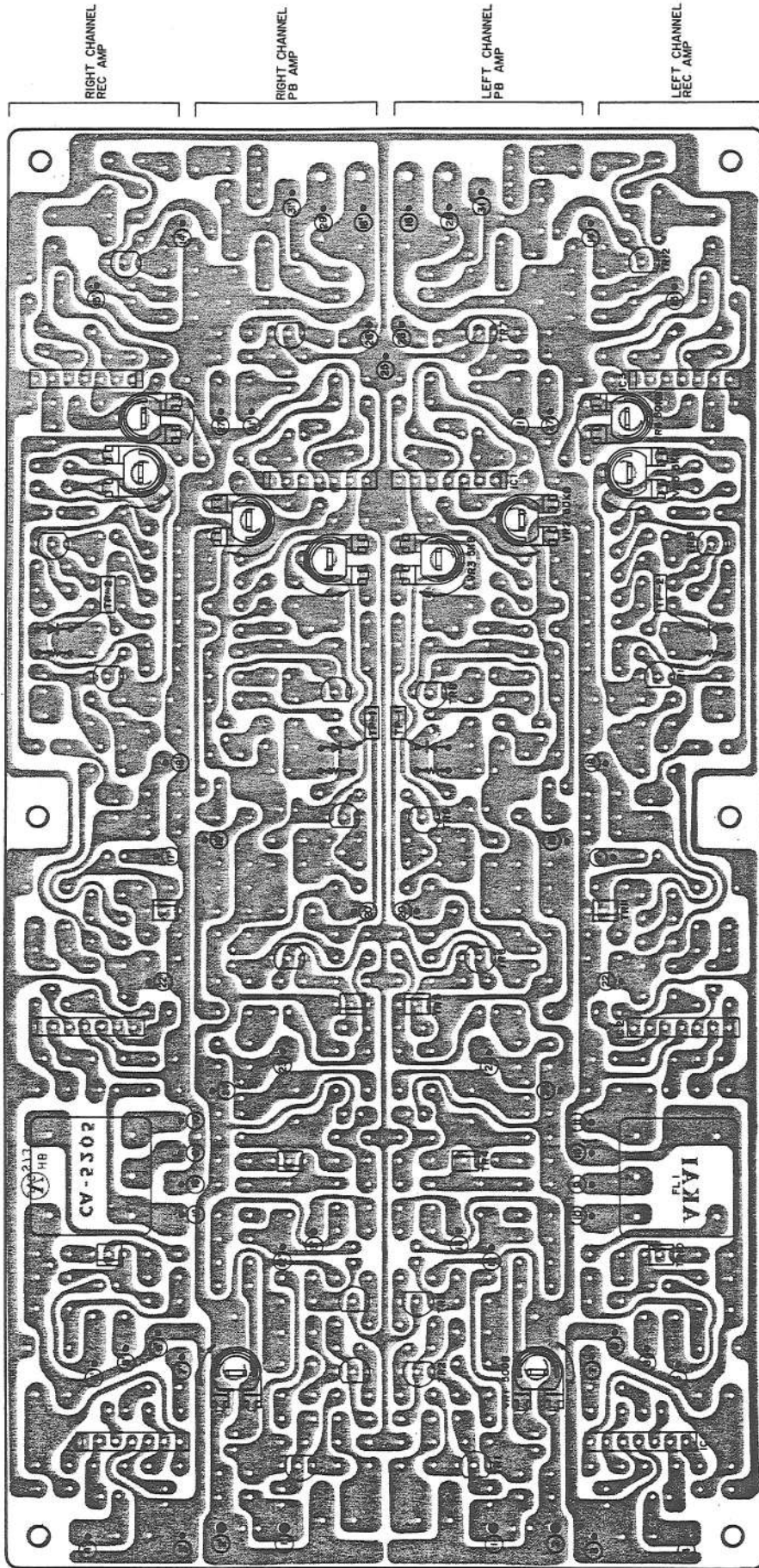

Fig-13 PRE AMP PC BOARD CA-5205

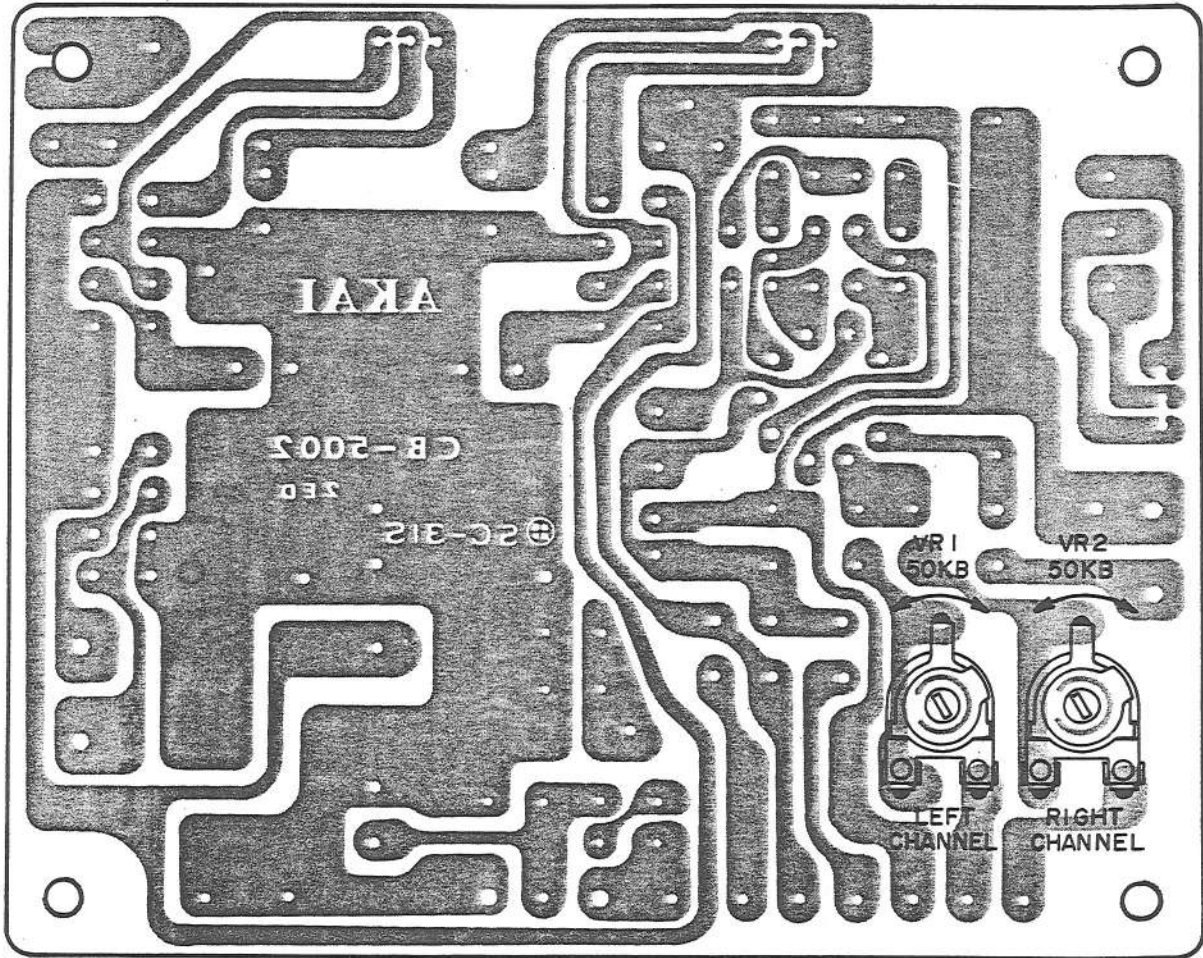

Fig-14 POWER SUPPLY & OSC P.C BOARD CB-5002

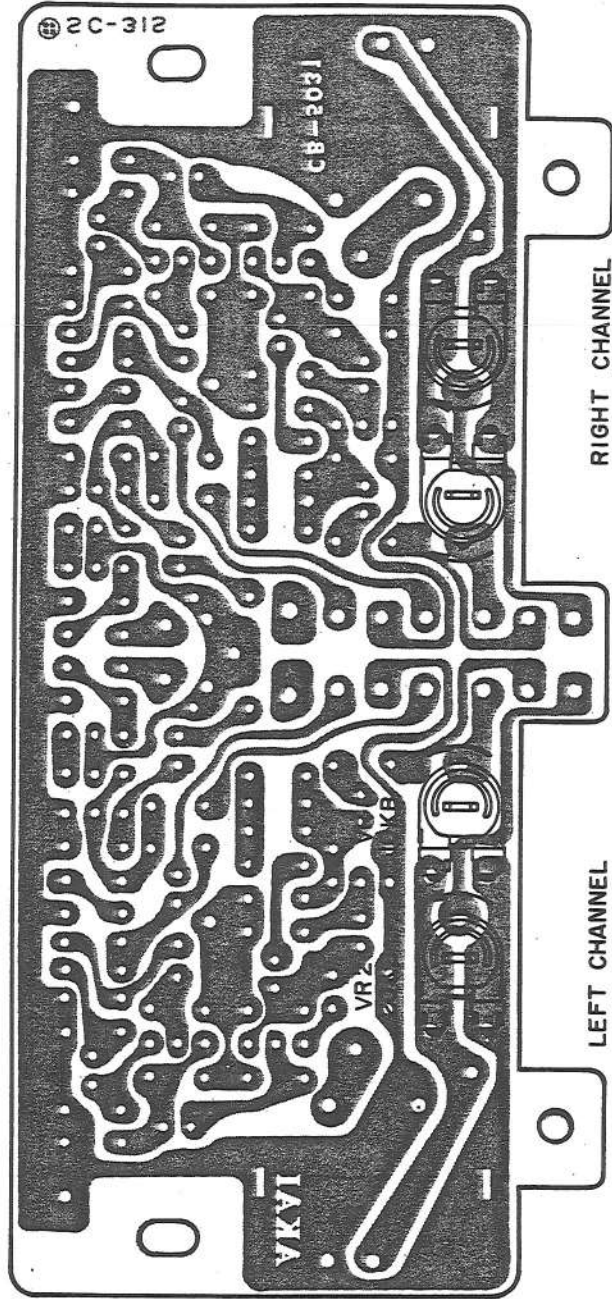

Fig-15 PEAK METER PC BOARD CB-5013

1. RECORDING/PLAYBACK AMPLIFIER ADJUSTMENT (Refer to Fig. 16, 17 and 18 and Chart-1)

Step	Adjustment Item	Test Tape Supply Signal	Mode	Adjustment Point	Result	Remarks
1	Playback Level Adjustment	333 Hz 0 VU Test Tape	PLAY	VR1, 500B (CA-5205)	0 ± 0.5 dBm (0.775V)	Set Monitor Switch to "TAPE".
2	Recording Level Adjustment (low noise tape)	Low Noise Blank Tape 1,000 Hz 0 VU recording	REC	VR4, 5 kB (left channel) VR5, 5 kB (right channel)	0 ± 0.5 dBm (0.775V)	Set Monitor Switch to "TAPE". Refer to Note-1)
3	Recording Level Adjustment (chrome tape)	Chrome Blank Tape 1,000 Hz 0 VU recording	REC	None	0 ± 3.5 dBm	Set Monitor Switch to "TAPE". Refer to Note-2)
4	Frequency Response Adjustment (low noise tape)	Low Noise Blank Tape 1,000 Hz 10,000 Hz -20 VU recording	REC	VR1, 50 kB (left channel) VR2, 50 kB (right channel) (CB-5002)	1,000 Hz 10,000 Hz Flat response	Set Tape Selector to "LOW NOISE"
5	Frequency Response Adjustment (chrome tape)	Chrome Blank Tape 1,000 Hz, 10,000 Hz -20VU recording	REC	VR3 100B (CB-5002)	1,000 Hz 10,000 Hz Flat response	Set Tape Selector to "CHROME"
6	Recording Level Confirmation (low noise tape)	Low Noise Blank Tape 1,000 Hz 0 VU recording	REC	VR4, VR5, 5 kB (Front Panel)	0 ± 0.5 dBm	Refer to Note-3)
7	VU Meter Sensitivity Adjustment	1,000 Hz	STOP	VR2, 20 kB (CB-5031)	0 VU	Refer to Note-4)
8	Peak Meter Indication Adjustment	1,000 Hz	STOP	VR1, 10 kB (CB-5031)	-8 VU	Refer to Note-4)

Chart-1

NOTES:

- Recording level adjustment volumes (REC CAL) VR4 and VR5 are not located on the pre-amp P.C Board as in the case of an ordinary tape deck, but are installed on the front panel.
- After low noise tape adjustments, confirm recording level only.
- Following Step 4 frequency response adjustment, because the recording level may be slightly changed, confirm level and if necessary, carry out Step 2 adjustment again.
- Set Monitor Switch to "SOURCE" and supply a 1,000 Hz signal to line input to obtain a 0 dBm line output level.
- Because each of these adjustments are vital to perfect Dolby N.R. circuit operation, be sure that they are carried out with as little error as possible.
- Use the following cassette measuring tape:
 - Low Noise Tape: Fuji C-60LN
 - Chrome Tape: BASF #SM Chrome C-60

2. DOLBY NOISE REDUCTION CIRCUIT ADJUSTMENT (Refer to Fig. 16)

NOTES:

1. Because the establishment of the (5 kHz) adjustment signal and level etc. is vital to correct Dolby Noise Reduction circuit adjustment, use only calibrated measuring instruments.
2. Level deviation must be within ± 0.5 dB.
3. After Dolby Noise Reduction circuit adjustments have been made, do not change recording and playback levels.
4. Set output control to maximum position prior to adjustments.

1) RECORDING DOLBY NOISE REDUCTION

AMPLIFIER ADJUSTMENT (Refer to Fig. 16)

- a. Set Monitor Switch to "SOURCE", and Tape Selector Switch to "LOW NOISE".
- b. Ground test point TP2 and turn adjustment semi-fixed resistor VR4, 50 k Ω and VR5, 5 k Ω as far as they will go in the direction of the arrow mark.
- c. With Recording Level Control set to 12 o'clock position, supply a 5 kHz signal to the line input and obtain a -28.5 dBm line output level.
- d. Connect an AC Voltmeter to the center terminal of front panel "REC CAL" Volume VR4 (left channel) and VR5 (right channel), and adjust "REC CAL" Volumes to obtain a -30 dBm AC Voltmeter indication.
- e. With the Dolby Noise Reduction Switch at ON, adjust semi-fixed resistor VR4, 50 k Ω shown in Fig. 16 to obtain a -20 dBm level at center terminal of "REC CAL" Volume.
- f. Disconnect test point TP2 from ground and adjust semi-fixed resistor VR5, 5 k Ω shown in Fig. 16 to obtain a -22 dBm level at center terminal of "REC CAL" Volume.

2) PLAYBACK DOLBY NOISE REDUCTION

AMPLIFIER ADJUSTMENT (Refer to Fig. 16)

- a. Set Monitor Switch to "TAPE" and Tape Selector switch to "LOW NOISE".
- b. Ground test point TP1 and turn adjustment semi-fixed resistors VR2, 50 k Ω and VR3, 5 k Ω as far as they will go in the direction of the arrow mark.
- c. Set deck to playback mode.
- d. Supply a 5 kHz signal to terminal (13) shown in Fig. 16 and obtain a -20.5 dBm line output level.
- e. Set the Dolby Noise Reduction Switch to ON and adjust semi-fixed resistor VR2, 50 k Ω shown in Fig. 16 to obtain a -30.5 dBm line output level.
- f. Disconnect test point TP1 from ground and adjust semi-fixed resistor VR3, 5 k Ω shown in Fig. 16 to obtain a -28.5 dBm line output level.

VIII. DC RESISTANCE OF VARIOUS COILS

Part	Designation	DC Resistance
Main Motor	SCM-700	Between YLW-BLU 210 ohms Between YLW-RED 197 ohms Between RED-BLU 190 ohms Pick-up coil 670 ohms
Play Solenoid	1660THT2	700 ohms $\pm 10\%$
Relay	MFS-2	1,000 ohms $\pm 10\%$
Relay	LC1-CJT	1,140 ohms $\pm 10\%$
Headphone Output Transformer	N19-349S	Primary 160 ohms $\pm 15\%$ Secondary 0.64 ohms $\pm 15\%$
Oscillator Coil	OT-925	Between 1-3 0.3 ohms Between 4-6 1.5 ohms Between 7-9 6.1 ohms
Recording, Playback Combination Head	PR4-2	Recording 22 ohms $\pm 5\%$ Playback 250 ohms $\pm 5\%$
Erase Head	E4-165	2.5 ohms

Chart-2

IX. CLASSIFICATION OF VARIOUS P.C BOARDS

1. RELATION OF P.C BOARD TITLE AND NUMBER

P.C Board Title	P.C Board Number
Pre Amp P.C Board	CA-5205
Power Supply & Osc P.C Board	CB-5002
Peak Meter P.C Board	CB-5031
SW. P.C Board	CB-2001
Relay P.C Board	CB-5001
Sys. Con P.C Board	CB-5004
Servo P.C Board	CB-2025
Noise Filter P.C Board	CB-2027
Stop Detection P.C Board	CB-2026
Lamp P.C Board	CB-2002
LED P.C Board	CA-2051

Chart-3

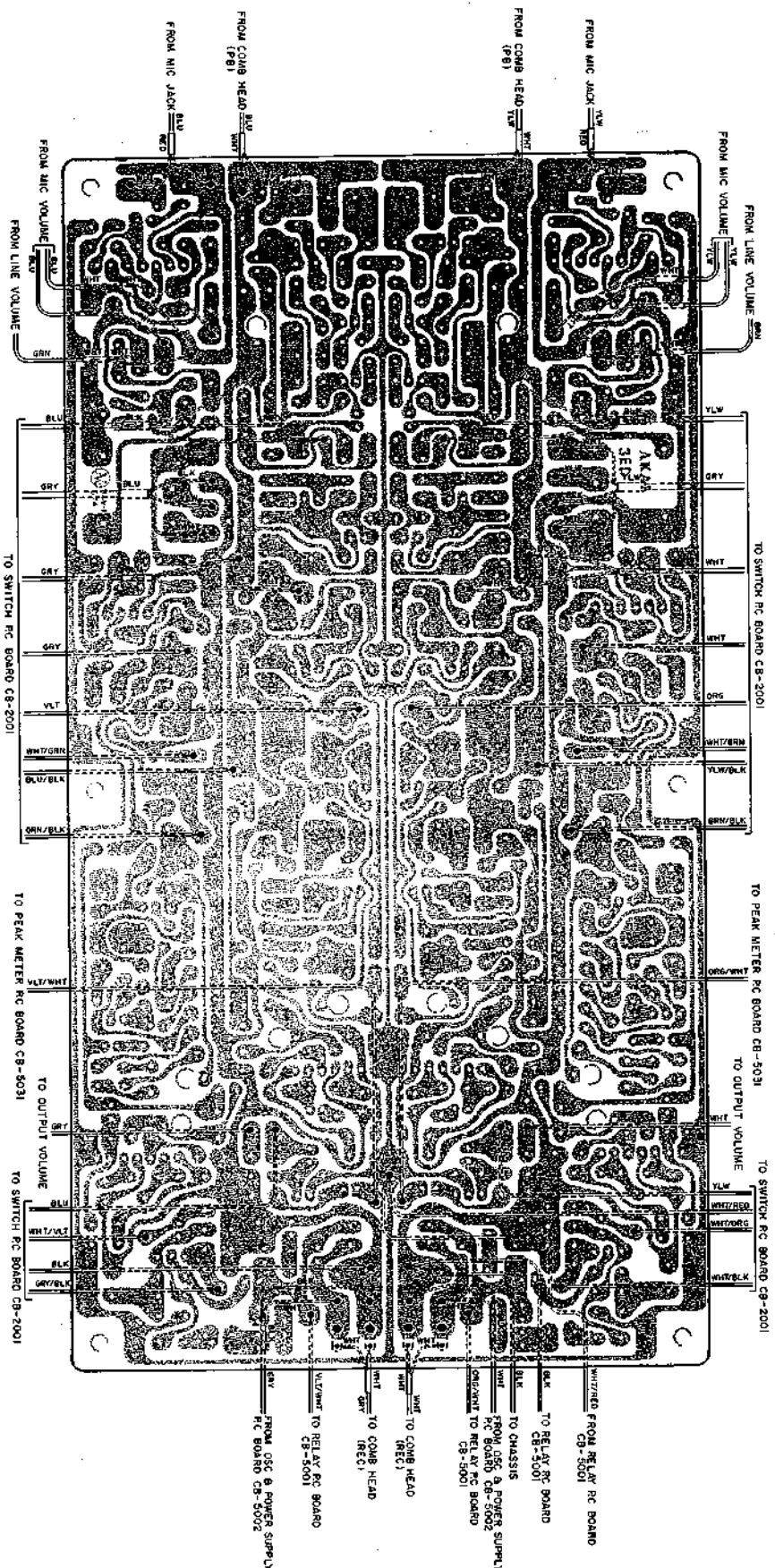

2) POWER SUPPLY OSC P.C BOARD CB-5002

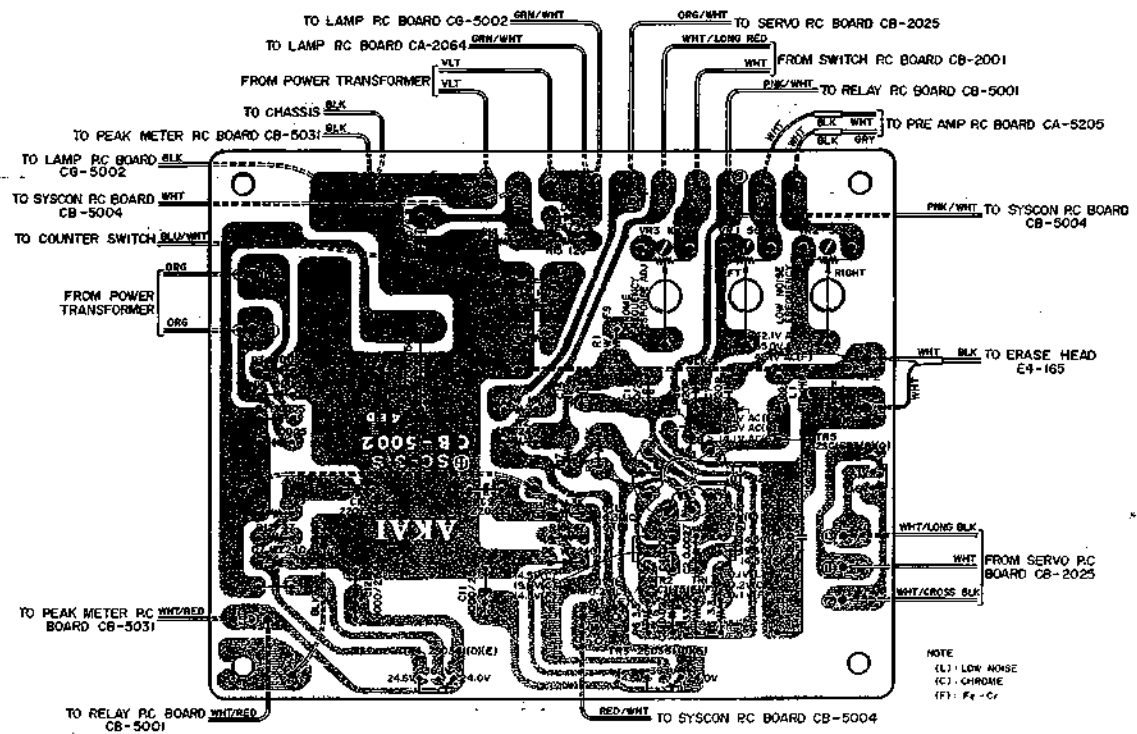

3) PEAK METER P.C BOARD CB-5031

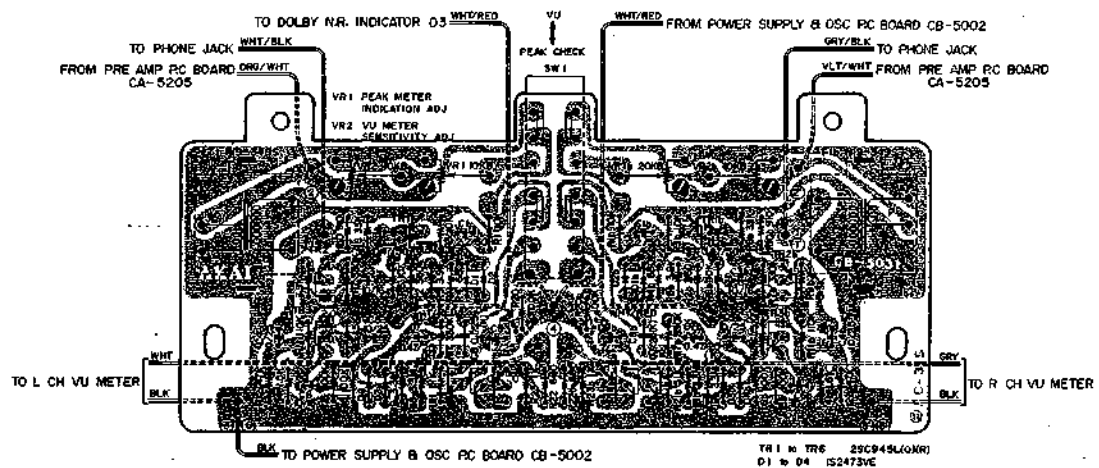

4) SW. P.C BOARD CB-2001

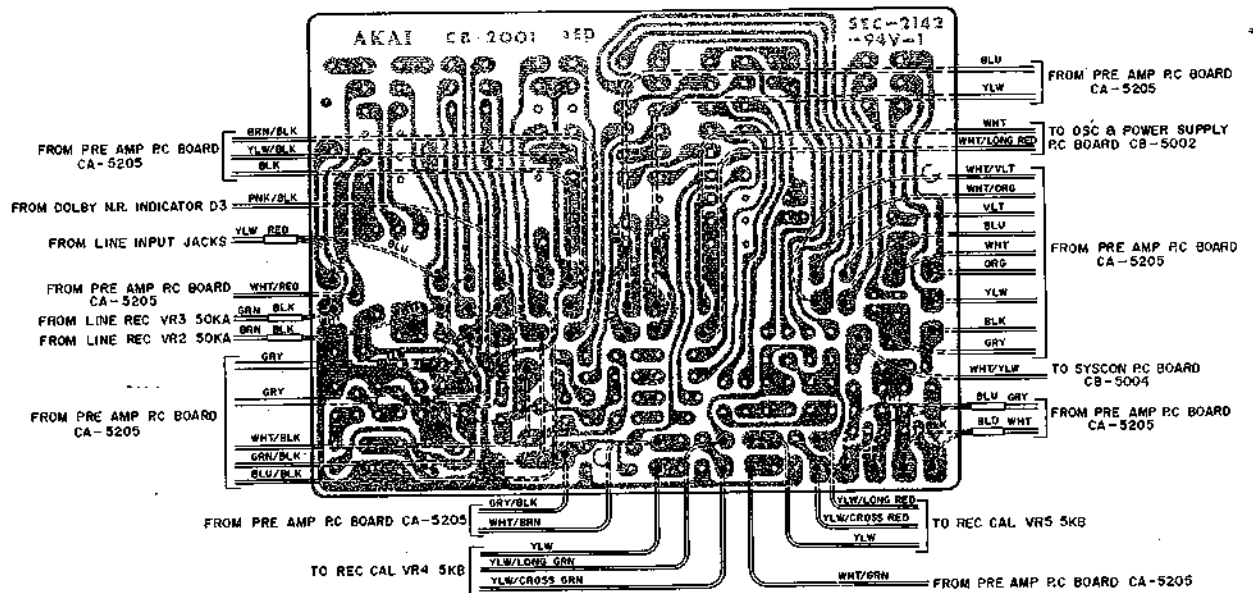
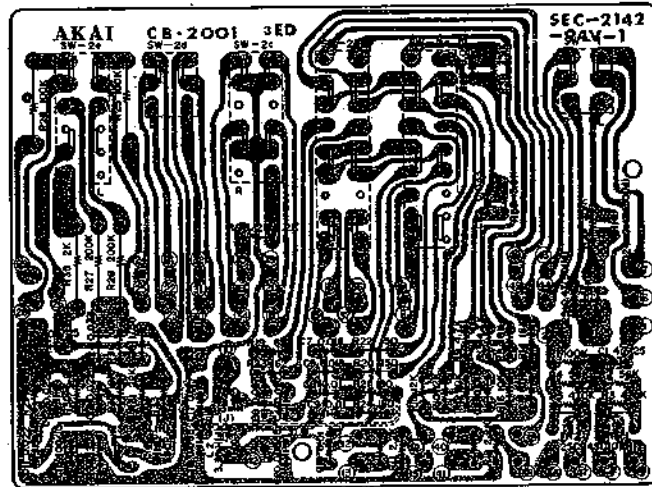
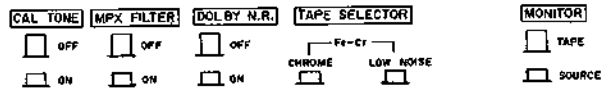

5) RELAY P.C BOARD CB-5001

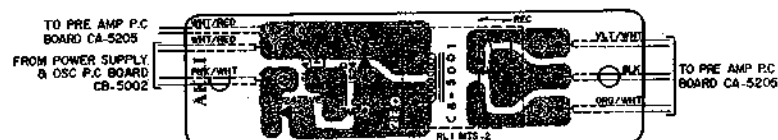

6) SYS. CON P.C BOARD CB-5004

TR1, TR2 258605(KHL) TR4 250360(DIE) TR8, TR11 25A628(E)(F)
TR3, TR9, TR10, TR15 to TR21, TR23, TR25 to TR34 25C945L(Q)(R) TR5, TR7, TR12, TR24 25D571(K)(L) TR22 25C121(E)(F)

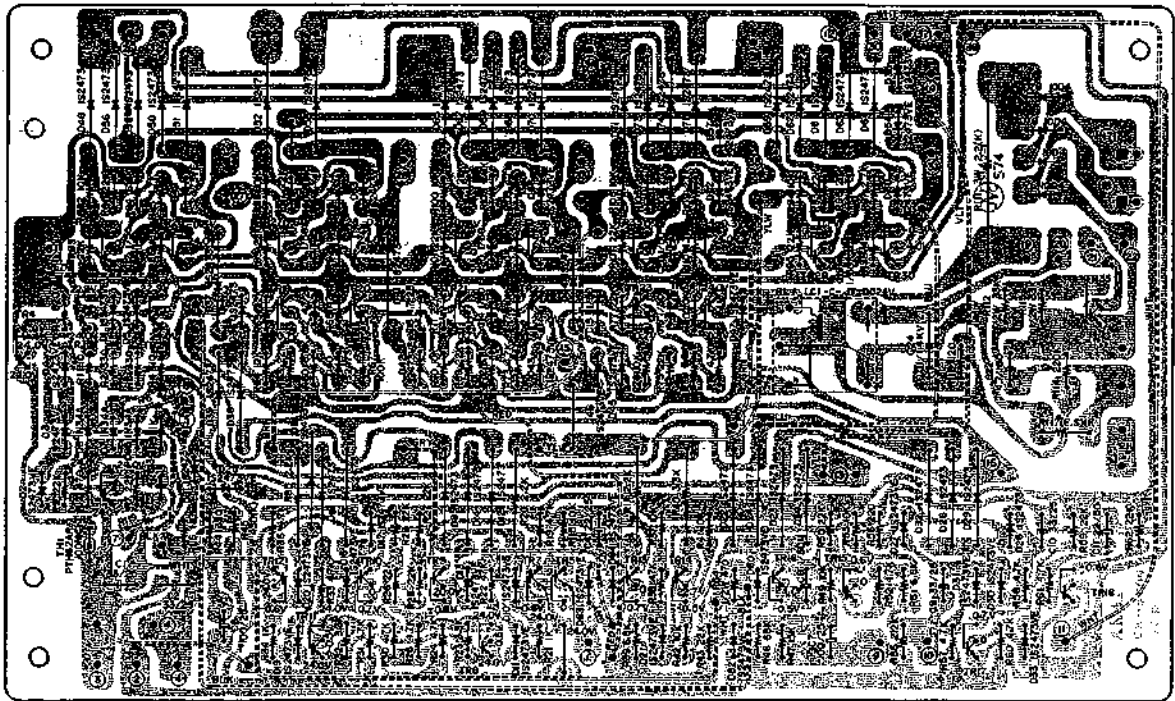

TR1, 2 258605(KHL) TR4 250360(DNE) TR8, 11 25A628(E)(F)
TR3, 9, 10, 13 to 21, 23, 25 to 34 25C945L(Q)(R) TR5, 7, 12, 24 25D571(K)(L) TR22 25C121(E)(F)

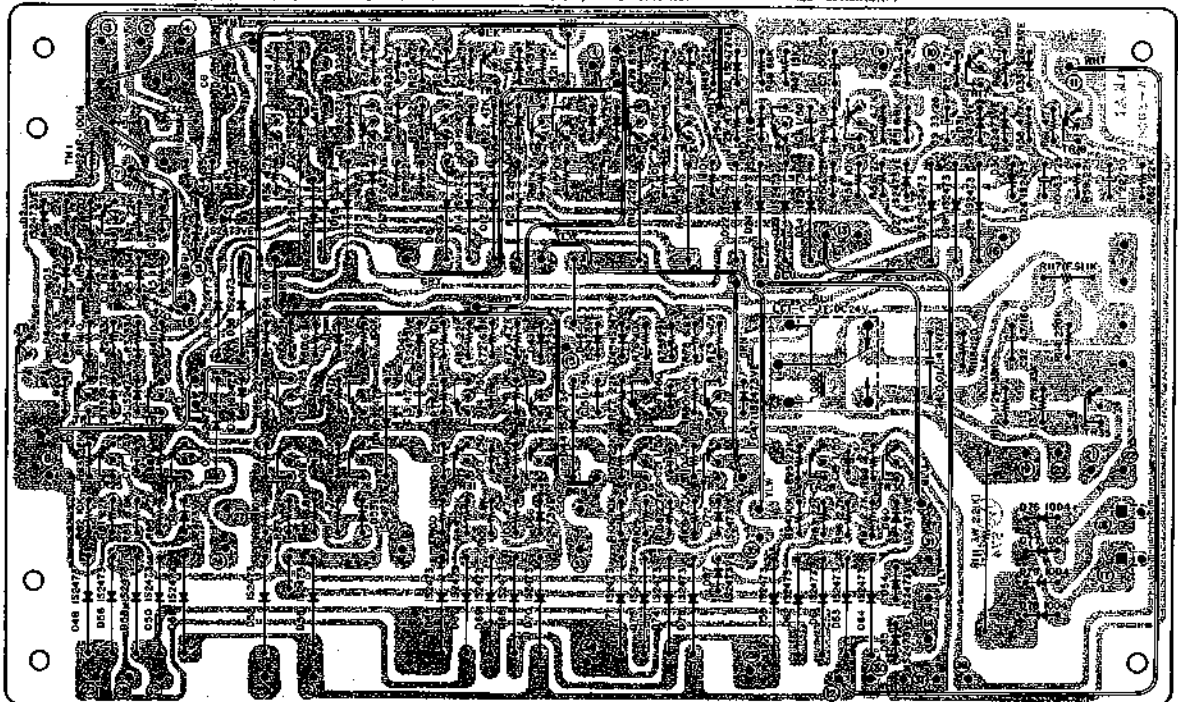

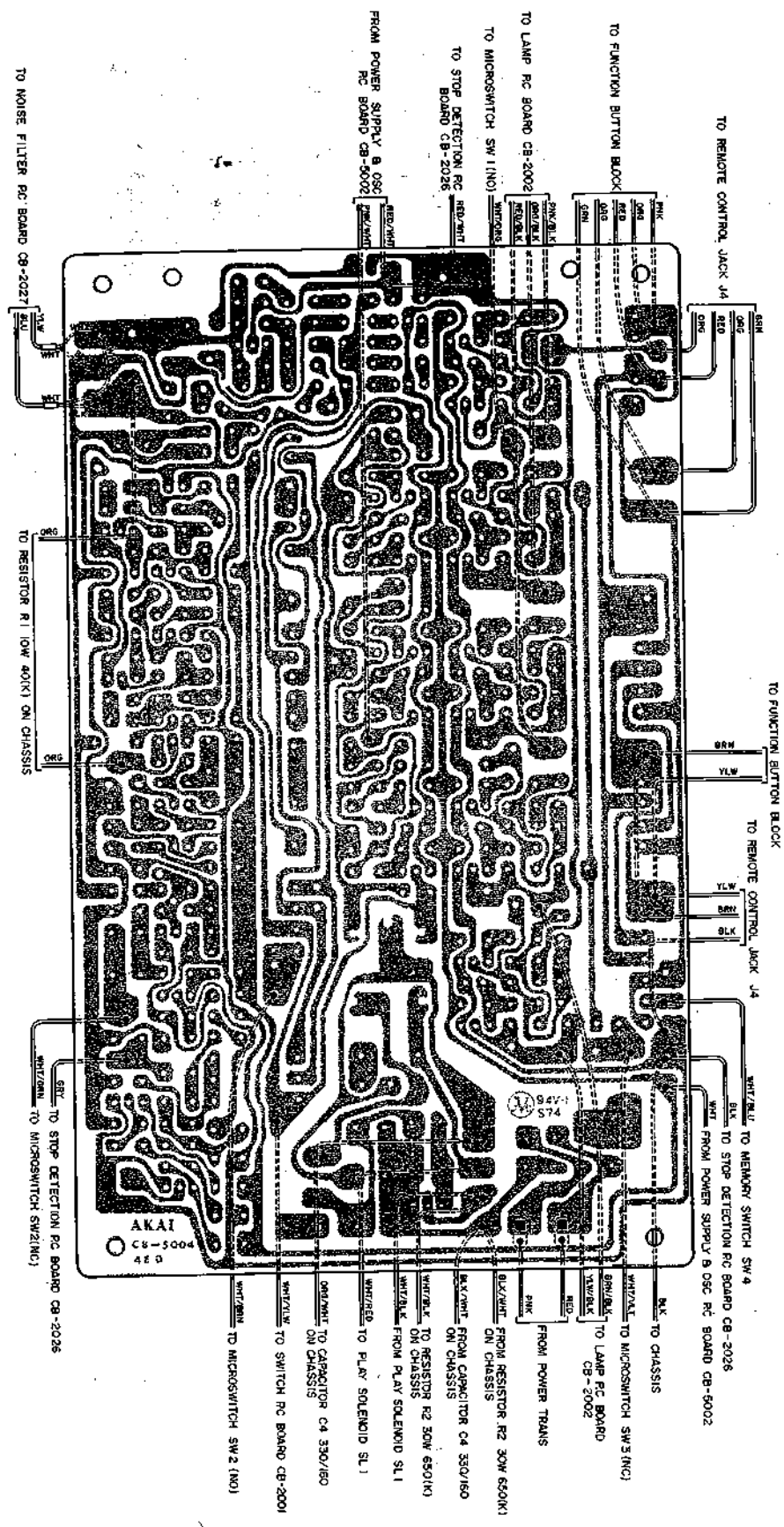

TO REMOTE CONTROL JACK J4

TO FUNCTION BUTTON BLOCK

TO LAMP PC BOARD CB-2002

TO MICROSWITCH SW 1(N)

TO STOP DETECTION PC BOARD CB-2026

FROM POWER SUPPLY B OSC PC BOARD CB-5002

TO NOISE FILTER PC BOARD CB-2027

TO FUNCTION BUTTON BLOCK

TO REMOTE CONTROL JACK J4

WHIT/BLK TO MEMORY SWITCH SW 4

BLK TO STOP DETECTION PC BOARD CB-2026

WHIT FROM POWER SUPPLY B OSC PC BOARD CB-5002

WHIT/BLK TO CHASSIS

WHIT/BLK TO MICROSWITCH SW 2(NC)

WHIT/BLK TO LAMP PC BOARD CB-2002

RED

FROM POWER TRANS

WHIT

BLK/WHIT FROM RESISTOR R2 30W 650K1 ON CHASSIS

BLK/WHIT FROM CAPACITOR C4 330/160 ON CHASSIS

WHIT/BLK TO RESISTOR R2 30W 650K1 ON CHASSIS

WHIT/BLK FROM PLAY SOLENOID SL 1

WHIT/RED TO PLAY SOLENOID SL 1

WHIT/WHIT TO CAPACITOR C4 330/160 ON CHASSIS

WHIT/WHIT TO SWITCH PC BOARD CB-2001

WHIT/WHIT TO MICROSWITCH SW 2 (NO)

TO RESISTOR R1 10W 40K1 ON CHASSIS

WHIT/WHIT TO STOP DETECTION PC BOARD CB-2026

WHIT/WHIT TO MICROSWITCH SW 2(NC)

AKAI
C4-5004
4E0

54V
574

7) SERVO P.C BOARD CB-2025

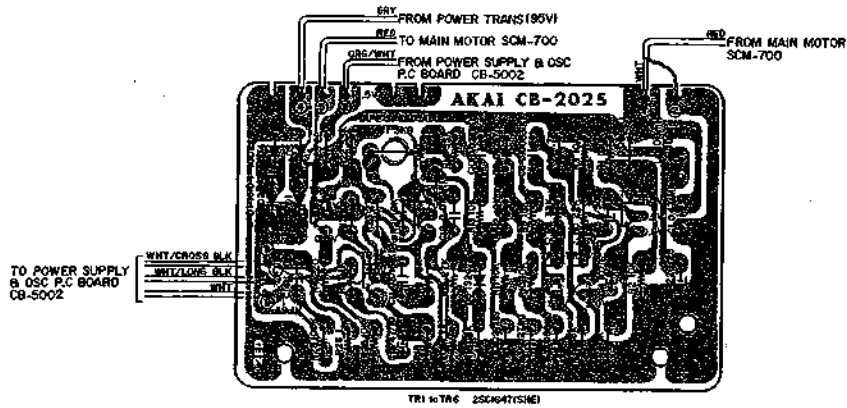

8) NOISE FILTER P.C BOARD CB-2027

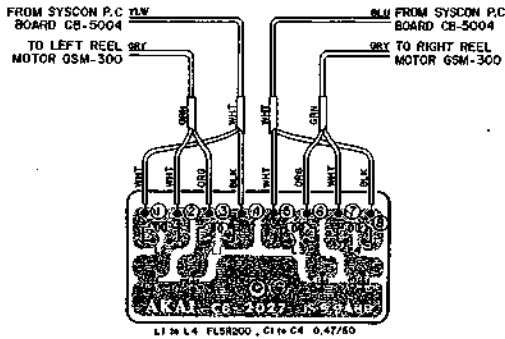

9) STOP DETECTION P.C BOARD CB-2026

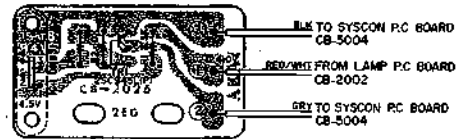

10) LAMP P.C BOARD CB-2002

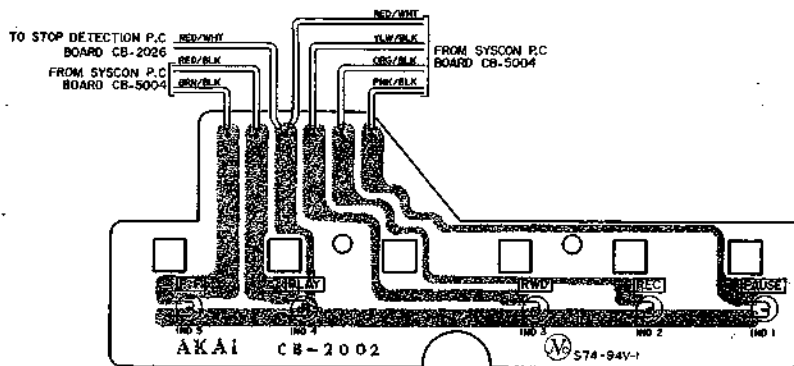

11) LED P.C BOARD CA-2051

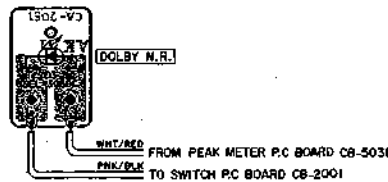

MEMO

MEMO

MEMO

MEMO

HOW TO USE THIS PARTS LIST

1. This parts list is compiled by various individual blocks based on assembly process.
2. When ordering parts, please describe parts number, serial number, and model number in detail.
3. How to read List

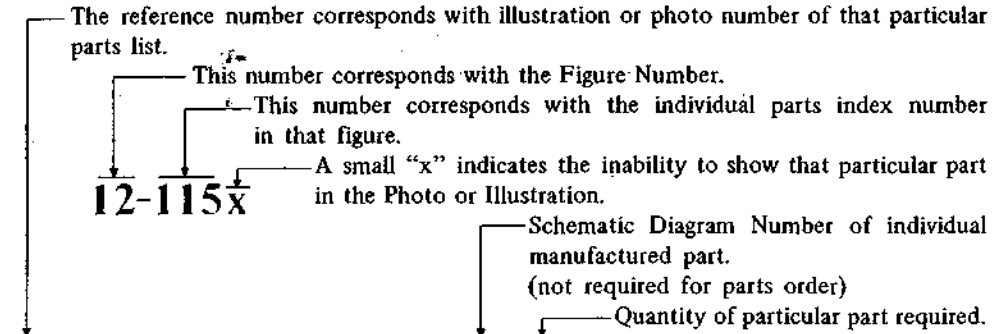

Ref. No.	Parts No.	Description	Schematic No.	Q'ty
FLYWHEEL BLOCK #13				
12-115x	800425	Flywheel Block Assy. Comp.	RDG #13	1
12-116	244506	Flywheel Only	RD-233	1
12-117x	244754	Felt, Flywheel	RD-275	1
12-118	251324	Main Metal Case	RD-236	1
12-119	253080	Main Metal	RD-237	1

4. The symbol numbers shown on the P.C. Board list can be matched with the Composite Views of Components of the Schematic Diagram or Service Manual.
5. Please utilize separate "Common List for Service Parts" for Resistor Parts orders.
6. The shape of the parts and parts name, etc. can be confirmed by comparing them with the parts shown on the Electrical Parts Table of P.C. Board.
7. Both the kind of part and installation position can be determined by the Parts Number. To determine where a parts number is listed, utilize Parts Index at end of Parts List.
It is necessary first of all to find the Parts Number. This can be accomplished by using the Reference Number listed at right of parts number in the Parts Index. (meaning of ref. no. outlined in Item 3 above).
8. Utilize separate "Price List for Parts" to determine unit price. The most simple method of finding parts Price is to utilize the reference number.

BASIC PARTS LIST

Parts Nomenclature	Parts No.	Parts Nomenclature	Parts No.
Cabinet CA-6008	BC647076	Power Transformer CBT-3	BT666731
Front Panel CB-6001	BZ670386	Power Transformer CBT-2	BT666720
Bottom Plate CA-6009	SP647054	Relay LC1-C-JT DC24V	EP616500
Circular Foot A CA-6014	SZ645243	Relay MTS-2	EP621808
Lid Panel B Block Comp.	BD681491	Solenoid Plunger 1660THT2	EP537906
Stop Detection P.C Board CB-2026	BA670195	2-axial 2-throw Volume V24L5DWTN A50kx2	EV669756
Lamp P.C Board CB-2002	BA670217	Co-axial 2-throw Volume GJ10E B10kx2	EV645851
Switch P.C Board CB-2001	BA670228	Volume V12M4-1N15FH B5k	EV669868
Noise Filter P.C Board CB-2027	BA670230	VU Meter KL-243S-30	EM684450
Servo P.C Board CB-2025	BA670252	Reel Table Block	BR670173
Syscon P.C Board CB-5004	BA670263	Main Motor SCM-700	BM670151
Pre Amp P.C Board CA-5205	BA671523	Main Motor SCM-700 (CSA)	BM670162
Relay P.C Board CB-5001	BA670274	Reel Motor GSM-300R	BM670140
Peak Meter P.C Board CB-5031	BA680027	Reel Motor GSM-300L	BM670138
Power Supply & OSC P.C Board CB-5002	BA670331	Flywheel CB-1018	BF667618
Protection P.C Board CB-5028	BA671207	Capstan Shaft CB-1022	MS667631
LED P.C Board CA-2051	EA647188	Steel Ball	MV666887
Rec, PB Combination Head PR4-2	HP671174	Capstan Belt CB-1034	MB669036
Erase Head E4-165	HE636963	Counter Belt CC-1034	MB415743
Head Base Block Comp.	BH661285	Counter SMP-390-79	MC666674
Push Button Knob J	SK634410	MP Capacitor 6 μ F 150WV AC	EC412582
Push Button Knob I	SK631304	Microswitch SS-5GL	ES477966
Single Knob B CA-6013	SK645030	Microswitch SS-5GL-13	ES494188
Double Knob (Upper) CA-6201	SK669993	Push Switch SPJ-10114B	ES619053
Double Knob (Lower) CA-6202	SK654750	Push Switch TV-3 JH5	ES479395
Rec CAL Knob CA-5203	SK669971	Push Switch JS-09	ES499972
Memory Cap CA-6010	SZ645221	Lamp 24V 35MA	EL619064
Operate Button Block	BZ670206	MPX Filter FB1801M	ER669734
Power Transformer CBT-1	BT664718		

1 ILLUSTRATION OF HEAD BASE/SUB FRAME BLOCK

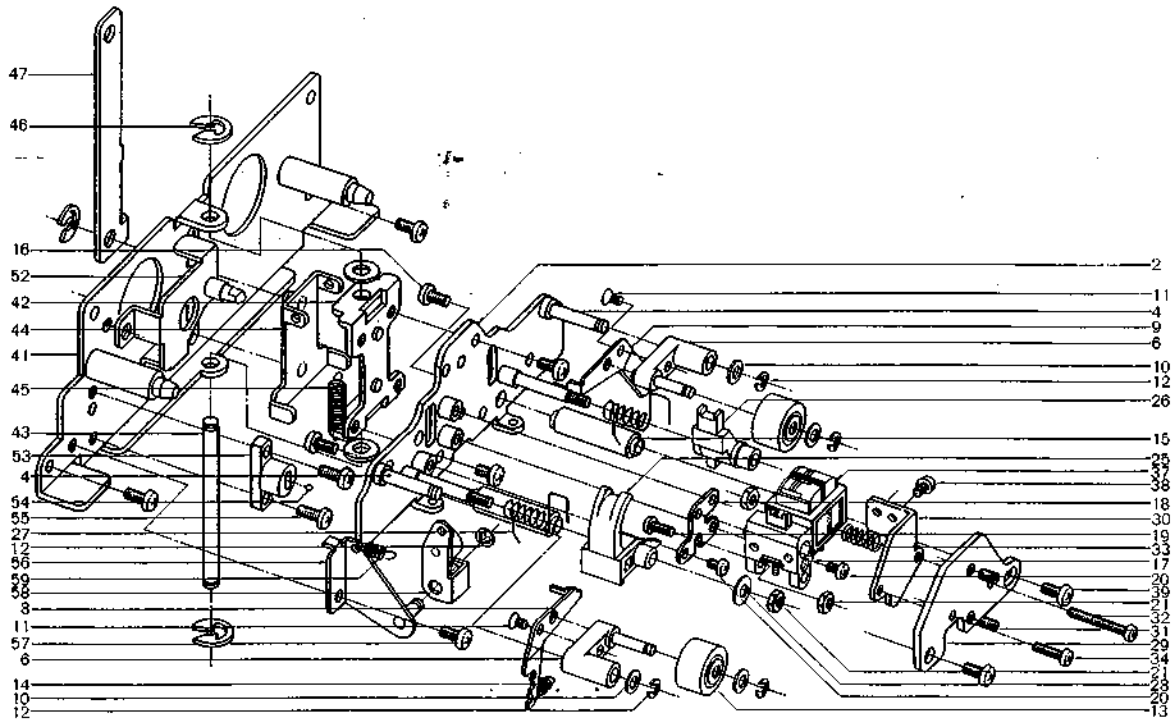

1) HEAD BASE/SUB FRAME BLOCK

Ref. No.	Parts No.	Description	Schematic No.	Q'ty	Ref. No.	Parts No.	Description	Schematic No.	Q'ty
HEAD BASE BLOCK					SUB FRAME BLOCK				
1-1x	BZ211105	Head Base Block Comp.	CA2,CB,CI	1	1-32	ZS303625	Screw, pan head 2.3x16		1
1-2	HZ227158	Head Table D (New)	CA-0018	1	1-33	ZG465636	Angle Adjust Spring	CG-0029	1
1-3x	HZ683673	Head Table B, w/shaft (old)	CA-0001	1	1-34	ZS391522	Screw, pan head 2.3x8		1
1-4	MS227136	PW Arm Shaft B	CA-0017	2	1-35x	ZW562476	Earth Lug M3		1
1-5x	ZW273756	Nut M3		2	1-36x	ZS417216	Screw, pan head 3x4		2
1-6	ML645063	PW Arm, w/shaft	CA-0004	2	1-37	BH671174	REC/PB HEAD PR4-2	CW,CA2,CB,CI	1
1-7x	ZW273745	Spring, Washer M3		2	1-38	ZS461395	Screw, round head 2x3		2
1-8	ML641621	Arm A	CA-0006	1	1-39	ZS379350	Screw, pan head 3x6		2
1-9	ML641632	Arm B	CA-0006	1	1-40x	EA669510	PR4-1 Terminal P.C Board	CW-0045	1
1-10	ZW364364	Washer (Polyslider) D3.1x5x0.25t		4	SUB FRAME BLOCK				
1-11	ZS524812	Screw, countersunk head 2x4		2	1-41	TC668092	Sub Frame, w/pin	CB-0001	1
1-12	ZW270088	'E' Ring 1.9M		5	1-42	TC667416	Head Table Guide	CB-0002	1
1-13	MP612628	Pinch Roller	CW-0010	2	1-43	MS667473	Guide Shaft B	CB-0007	1
1-14	ZG644411	PW Arm Spring	CA-0009	2	1-44	TC667427	Head Table Slide 1, w/pin 3	CB-0003	1
1-15	HZ644400	Head Hanger Post	CA-0007	2	1-45	ZG542215	Spring B	CZ-1011	2
1-16	ZS379405	Screw, binding head 3x6		2	1-46	ZW290283	'U' Ring 2.85M	6-1-1	4
1-17	HE636963	ERASE HEAD E4-165	CW,CA2,CB,CI	1	1-47	TC667451	Play Lever Joint	CB-0006	1
1-18	HZ227103	Erase Head Plate B (New)	CA-0213	1	1-48x	ZW450753	Washer (Nylon) D4.1x9x1t		1
1-19	ZS464692	Screw, binding head 2.3x6		1	1-49x	ZW222388	Washer (Rubber)	24X-739	1
1-20	ZS477876	Screw, pan head 2x3		2	1-50x	ZW562476	Earth Lug M3		1
1-21	ZW485728	Nut M2.3		4	1-51x	ZS325495	Tapping Screw #2 3x6 (BR)		1
1-22x	ZS608106	Screw, pan head 2x6		1	1-52	TC667438	Reference Table, w/pin	CB-0004	1
1-23x	ZG227114	EH Adjust Spring (New)	CA-0214	1	1-53	MS645153	Ball Guide	CA-2013	1
1-24x	ZW273666	Spring Washer M2.3		1	1-54	MV522235	Steel Ball 3/32 inch		1
1-25	MS659913	Tape Guide B	CA-0208	1	1-55	ZS422076	Screw, pan head 3x5		4
1-26	MS659902	Tape Guide	CA-0207	1	1-56	MZ642104	Arm Shaft Bracket, w/shaft	CA-2016	1
1-27	ZG659880	Tape Guide Spring	CA-0205	2	1-57	ZS417216	Screw, pan head 3x4		1
1-28	ZW669148	Washer D2.3x7x0.3t		2	1-58	TC642115	Pressure Roller Arm, w/roller	CA-2018	1
1-29	HZ669892	Head Hanger B	CA-0201	1	1-59	ZG569384	Selector Spring	CP-1166	1
1-30	HZ669903	Head Mt. Parts	CA-0203	1	1-60x	ZG386335	Stop Lever Spring	CS-3011	1
1-31	ZS356804	Set Screw, hexagon socket 3x4 (cup/p.)		2	1-61x	HZ567202	Erase Head Plate (old)	CP-0029	1

When ordering parts, Please describe Parts Number, Serial Number, and Model Number in detail.

2 ILLUSTRATION OF REEL MOTOR/TABLE BLOCK

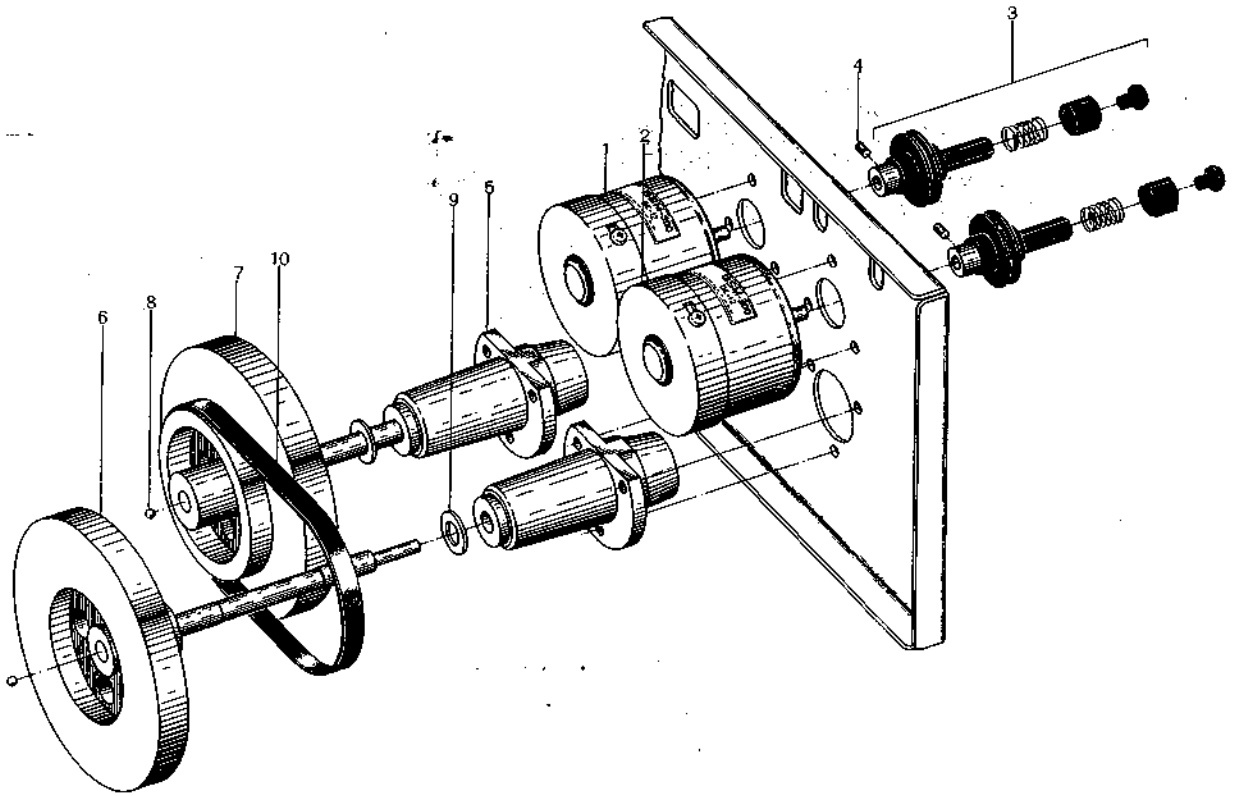

2) REEL MOTOR/TABLE BLOCK

Ref. No.	Parts No.	Description	Schematic No.	Qty
REEL MOTOR BLOCK				
2-1	BM670140	Motor (GSM-300R) Block		
		Comp.	CB,CI	1
2-2	BM670138	Motor (GSM-300L) Block		
		Comp.	CB,CI	1
REEL TABLE BLOCK				
2-3	BR670173	Reel Table Block Comp.	CB,CI	1
2-4	ZS521987	Set Screw, hexagon socket 2.6x4 (cup/p.)		1
2-5	TC667620	Min Case	CB-1020	2
2-6	BF667618	Flywheel A	CB-1018	1
2-7	BF668790	Flywheel B	CB-1018	1
2-8	MV666887	Steel Ball D2.5		2
2-9	ZW597543	Thrust Washer A (Nylon) 1t	KJ-7009	2
2-10	MB669036	Capstan Belt	CB-1034	1

3 ILLUSTRATION OF MOTOR BLOCK

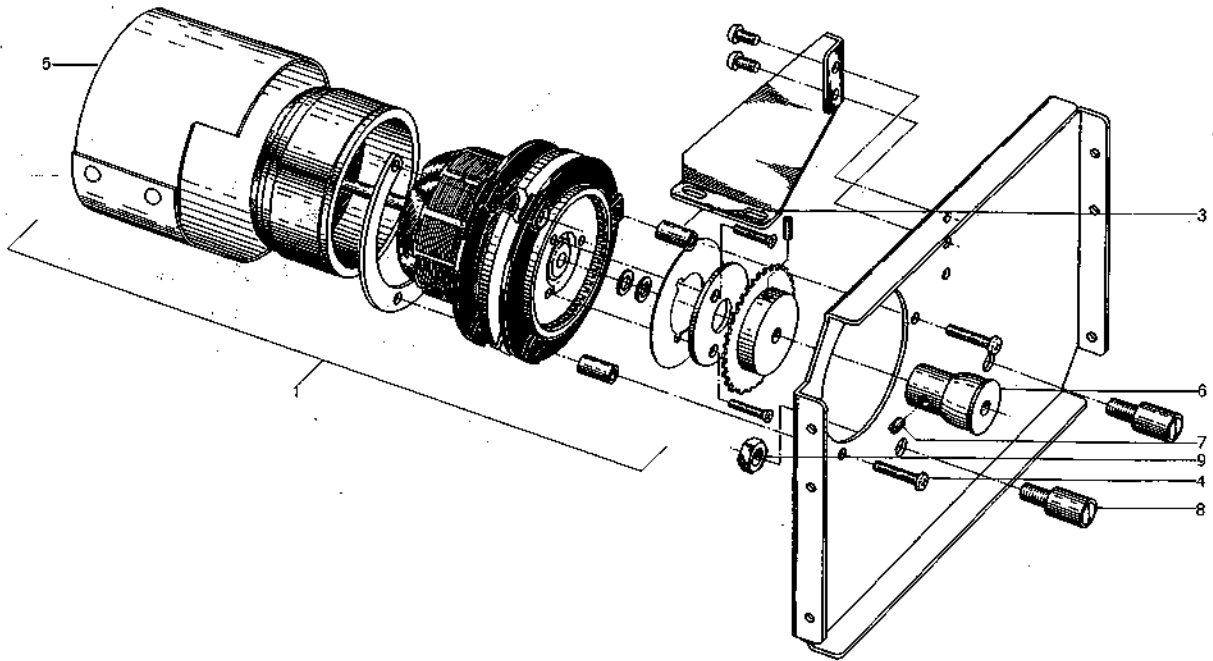

3) MOTOR BLOCK

Ref. No.	Parts No.	Description	Schematic No.	Q'ty
3-1	BM670151	Motor Block Comp. (SCM-700)		1
3-2x	BM670162	Motor Block Comp. (SCM-700) (CSA)		1
3-3	MZ659981	Stop Tube	CA-2205	3
3-4	ZS422965	Screw, pan head 3x15		3
3-5	MZ668968	Motor Shield	CB-7034	1
3-6	MR668068	Motor Pulley	CB-7003	1
3-7	ZS356804	Set Screw, hexagon socket 3x4 (cup/p.)		2
3-8	MZ668057	Capstan Support	CB-7002	2
3-9	ZW668452	Metal Nut	7-1-64	2

When ordering parts, Please describe Parts Number, Serial Number, and Model Number in detail.

4 ILLUSTRATION OF OPERATE BUTTON BLOCK

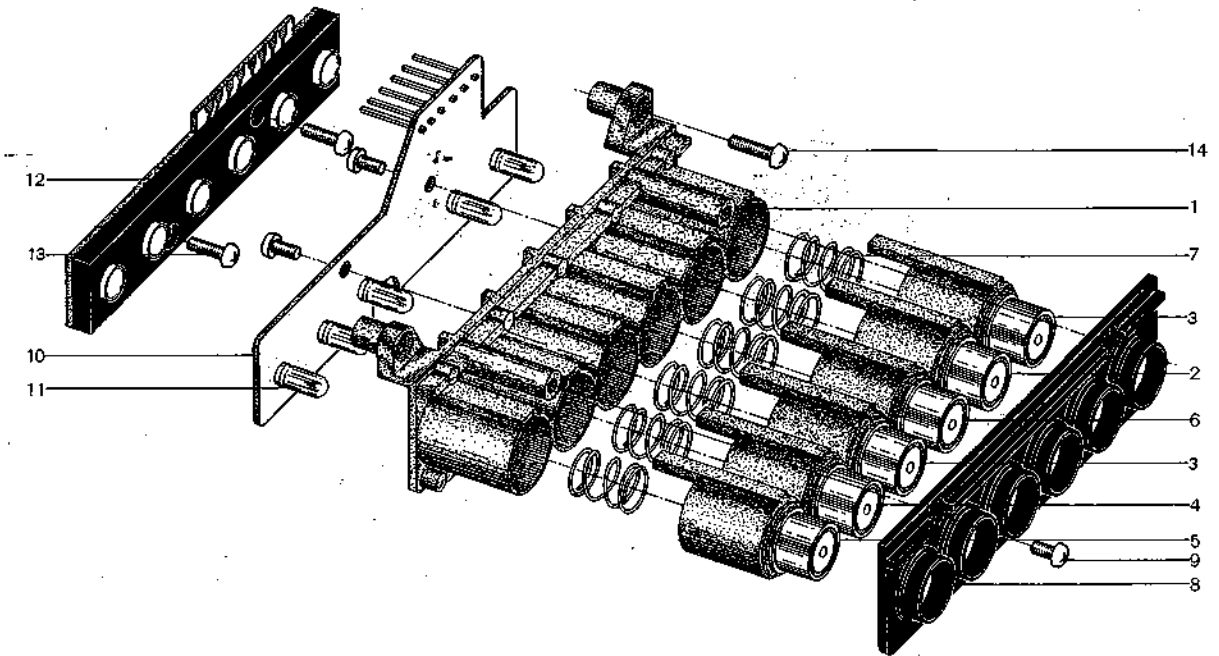

4) OPERATE BUTTON BLOCK

Ref. No.	Parts No.	Description	Schematic No.	Q'ty
4-1	TC668125	Button Base	CB-2004	1
4-2	BZ667844	Button Color Comp. A	CB-2012	1
4-3	BZ667855	Button Color Comp. B	CB-2012	2
4-4	BZ667866	Button Color Comp. C	CB-2012	1
4-5	BZ667877	Button Color Comp. D	CB-2012	1
4-6	BZ667888	Button Color Comp. E	CB-2012	1
4-7	ZG667811	Button Spring	CB-2009	6
4-8	SZ684696	Button Cover	CB-2013	1
4-9	ZS325495	Tapping Screw #2 3x6 (BR)		4
4-10	BA670217	Lamp P.C Board Comp.	CB-2002	1
4-11	EL619064	Lamp (L/T) 24V 35MA	28-2-40	5
4-12	ES666685	Keyboard SW. CB	25-5-198	1
4-13	ZS666336	Tapping Screw #2 3x8 Pan head		2
4-14	ZS462802	Tapping Screw #2 3x15 (BR)		3

5 ILLUSTRATION OF CASSETTE HOLDER BLOCK

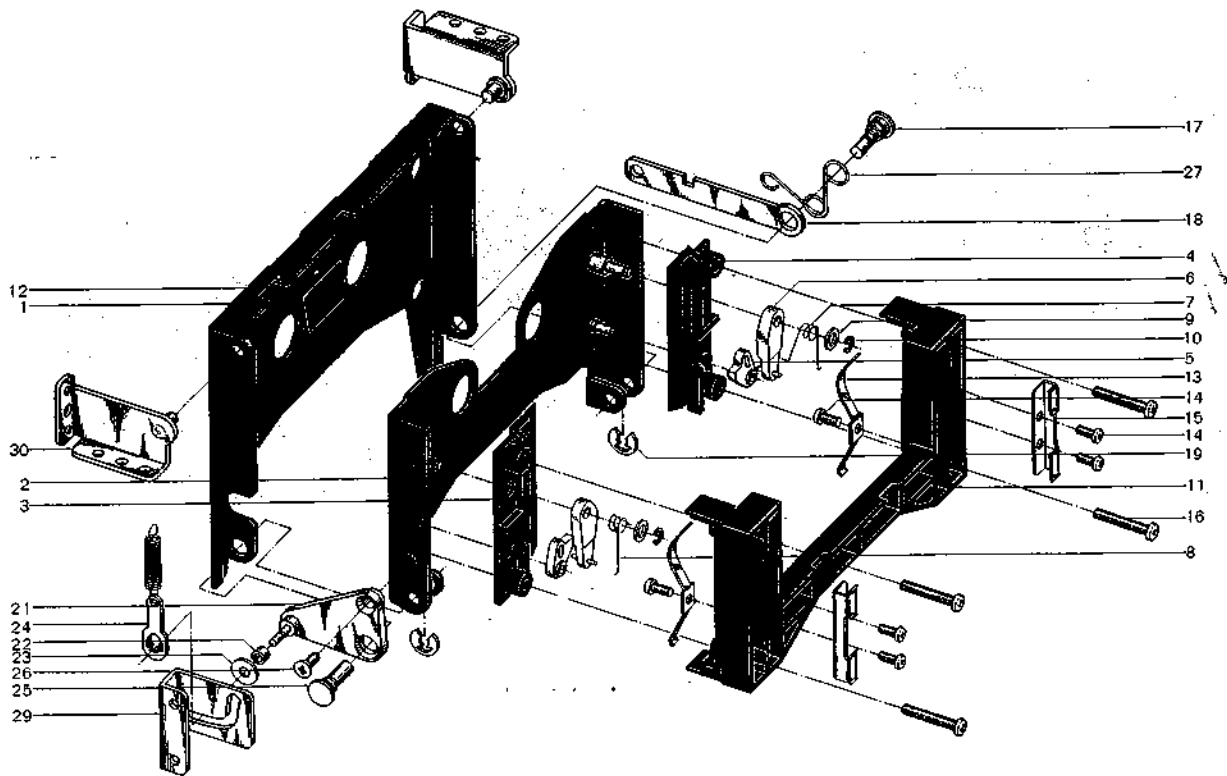

5) CASSETTE HOLDER BLOCK

Ref. No.	Parts No.	Description	Schematic No.	Q'ty
5-1	TC646931	Trap, w/boss	CA-2020	1
5-2	TC646920	Cassette Holder	CA-2023	1
5-3	MS595563	Cassette Guide L	CH-2007	1
5-4	MS595552	Cassette Guide R	CH-2006	1
5-5	ML595574	Detector Lever A	CH-2008	2
5-6	ML595585	Cassette Lever B	CH-2009	2
5-7	ZG595618	Spring A	CH-2004	1
5-8	ZG595620	Spring B	CH-2005	1
5-9	ZW592391	Washer (PBP) D3.2x6x0.3t		2
5-10	ZW270088	'E' Ring 1.9M	6-1-9	2
5-11	TC647065	Cassette Case	CA-2024	1
5-12	TC645186	Reflector	CA-2071	1
5-13	ZG207257	Sheet Spring B	CI-2019	2
5-14	ZS669104	Tapping Screw #2 2.3x6 pan head		6
5-15	TC642148	Lid Chuck	CA-2026	2
5-16	ZS592402	Screw, pan head 3x18		4
5-17	MH664064	Hinge Pin B	CB-2029	1
5-18	TC666156	Band Plate B	CB-2024	1
5-19	ZW290283	'U' Ring 2.85M	6-1-1	1
5-20x	ZW260122	Washer (Nylon) D6.1x10x1t		1
5-21	ML699412	Eject Guide Arm A	CA-2027	1
5-22	MR203804	Roller	CB-1056	1
5-23	ZW259503	Washer (Nylon) D3.1x8x0.5t		1
5-24	MZ203815	Spring Hook	CB-1057	1
5-25	MH644916	Hinge Pin	CA-2028	1
5-26	ZS414033	Screw, countersunk head 3x8		1
5-27	ZG227452	Spring D	CA-2031	1
5-28x	ZW322110	Washer (Nylon) D6.1x10x1.0t		1
5-29	MS642374	Eject Guide	CA-2066	1
5-30	TC642071	Pin Stand	CA-1099	2

When ordering parts, Please describe Parts Number, Serial Number, and Model Number in detail.

6 ILLUSTRATION OF MECHA FRAME BLOCK (1)

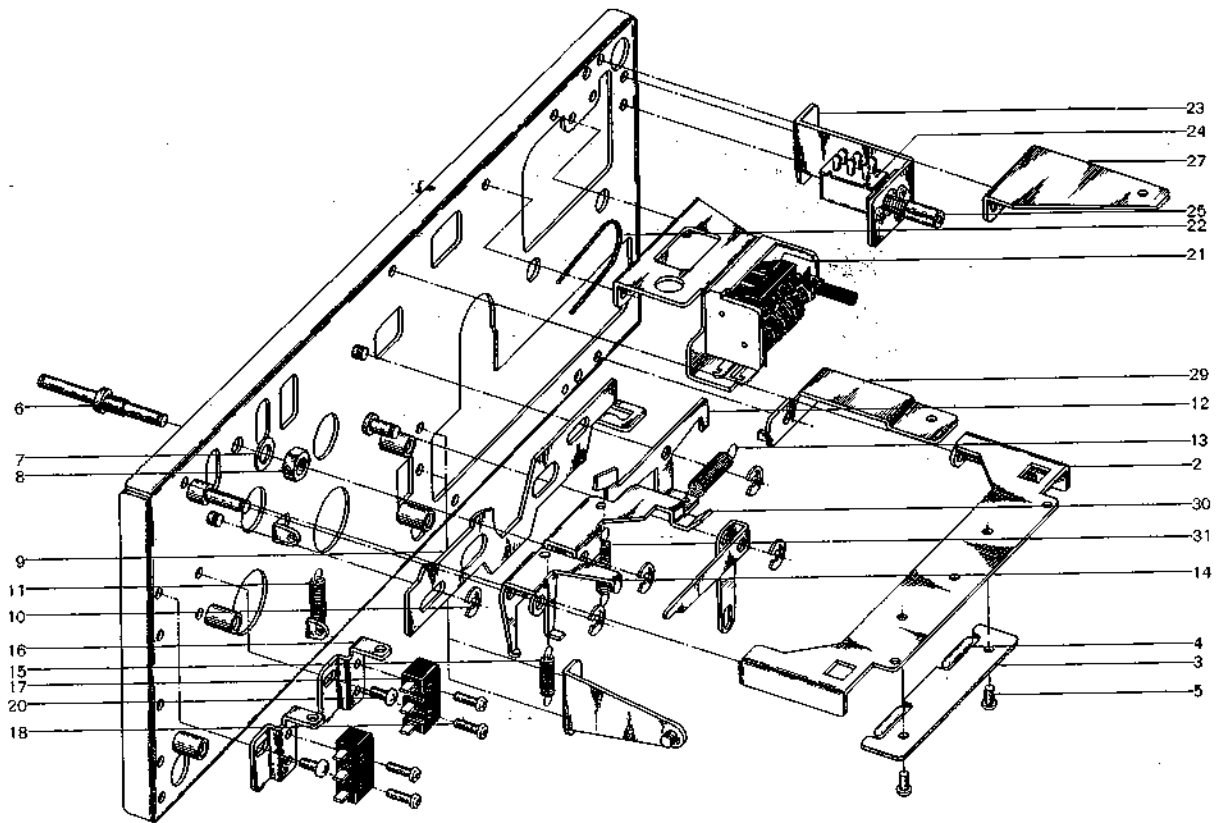

6) MECHA FRAME BLOCK (1)

Ref. No.	Parts No.	Description	Schematic No.	Q'ty	Ref. No.	Parts No.	Description	Schematic No.	Q'ty
LAMP STAND BLOCK									
6-1x	BZ681917	Lamp Stand Block Comp.	CB	1	6-16	TC667574	M SW. Table A	CB-1012	2
6-2	TC642363	Lamp Stand	CA-2065	1	6-17	ES477966	Micro SW. SS-5GL	25-1-23	2
6-3	EA647190	Lamp P.C Board	CA-2064	1	6-18	ZS487091	Screw, pan head 2.3x8		4
6-4	EL295312	Lamp (L/T) 8V 0.2A	28-2-8	2	6-19x	ZW273633	Earth Lug M2.3		1
6-5	ZS417161	Screw, pan head 2.3x4		3	6-20	ZS325495	Tapping Screw #2 3x6 (BR)		4
MECHA. FRAME BLOCK									
6-6	MH667506	Head Table Arm Prop	CB-1004	1	6-21	BZ699996	Counter Block Comp.	CB-1048	1
6-7	ZW675033	Washer D5.1x10.3x0.8t		1	6-22	MB415743	Counter Belt A D96x1x1	CC-1034	1
6-8	ZW668452	Metal Nut	7-1-64	1	6-23	TC667721	SW. Bracket	CB-1031	1
6-9	TC693303	Joint Slide	CI-1006	1	6-24	ES619053	Push SW. SPJ-10114B	25-5-144	1
6-10	ZW290283	'U' Ring 2.85M	6-1-1	2	6-25	SZ645221	Memory Cap	CA-6010	1
6-11	ZG224796	New Spring D	μMH-142	1	6-26x	BZ651240	Spacer 3x10	7-2-6	3
6-12	TC690412	Protector Plate	CI-1017	1	6-27	TC667642	Panel Support A	CB-1023	1
6-13	ZG217337	Belt Return Spring	4TR-224	1	6-28x	MT553948	Wire Band B	2-35-3	2
6-14	ML667462	Rec Lever, w/pin (2)	CB-1006	1	6-29	TC220871	Panel Support C	CB-1058	1
6-15	ZG359638	FF Idler Wheel A Spring	PX-146	1	6-30	ML667528	Detector Lever, w/pin (2)	CB-1007	1
					6-31	ZG392804	Auto. Change Lever E Return Spring	CS-2566	1

7 ILLUSTRATION OF MECHA FRAME BLOCK (2)

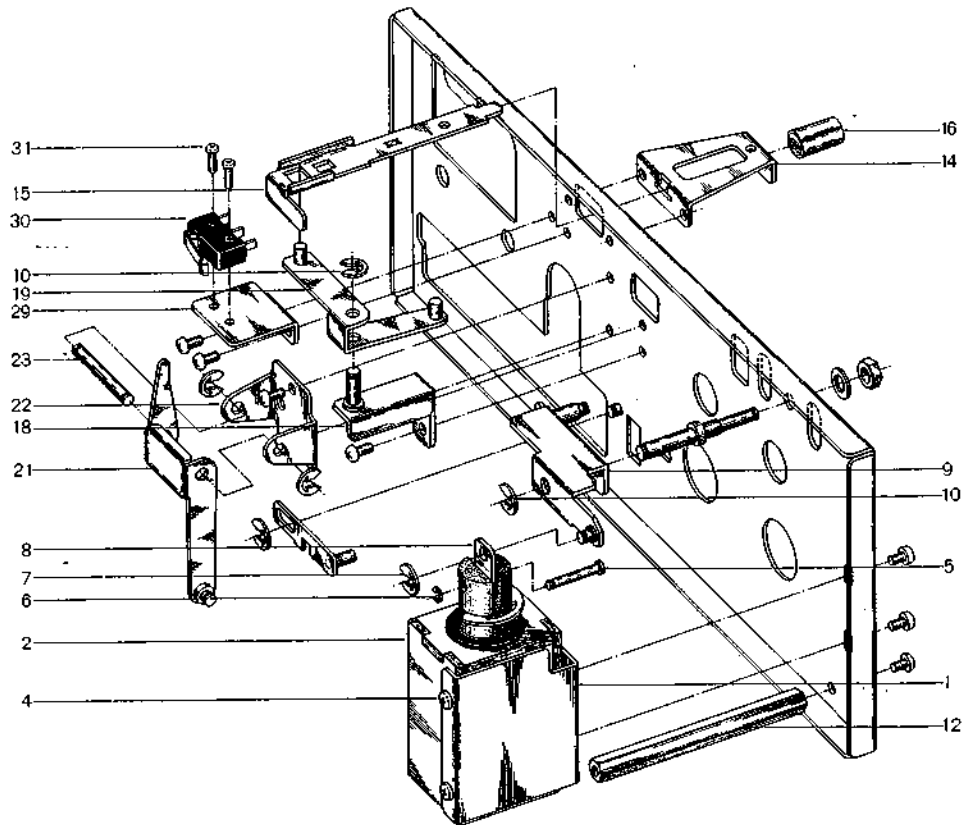
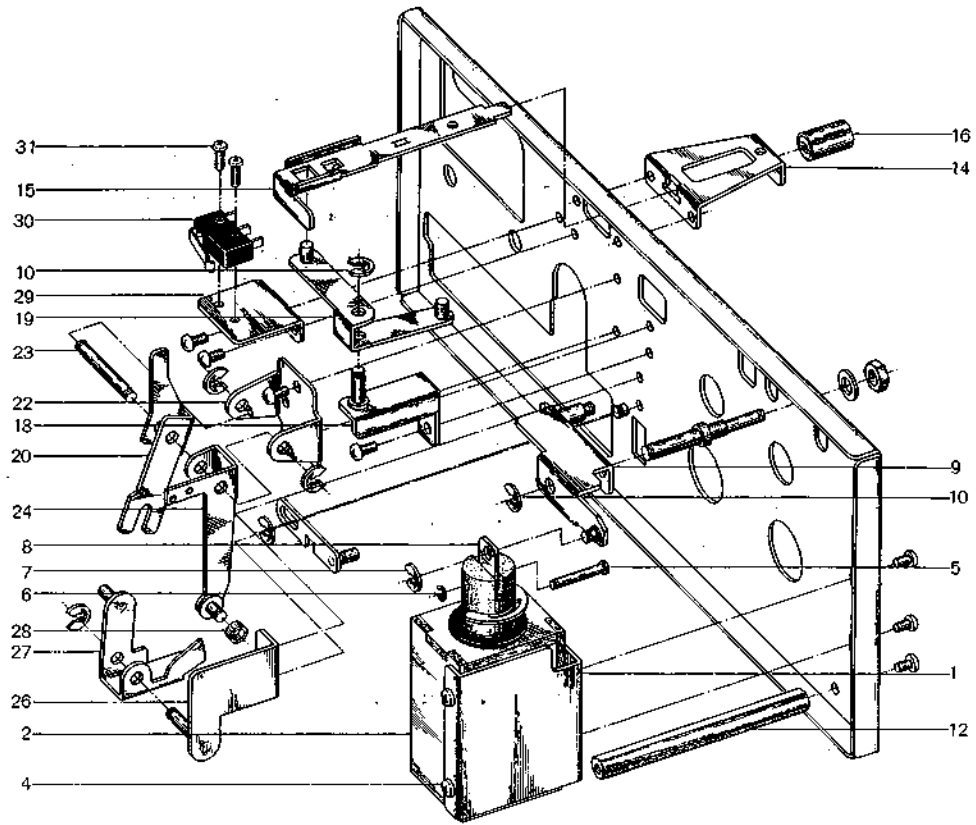

When ordering parts, Please describe Parts Number, Serial Number, and Model Number in detail.

7) MECHA FRAME BLOCK (2)

Ref. No.	Parts No.	Description	Schematic No.	Q'ty
PLUNGER BLOCK				
7-1	TC667956	Plunger Mount	CB-2023	1
7-2	EP537906	Plunger Solenoid 1660THT2	44-1-54	1
7-3x	ED224550	Silicon Diode 10D4	45-2-16	1
7-4	ZS422076	Screw, pan head 3x5		2
7-5	MH533913	Connecting pin	TW-2010	1
7-6	ZW270088	'E' Ring 1.9M	6-1-9	1
7-7	ZW270101	'E' Ring 3M	6-1-9	1
7-8	TC667945	Plunger Joint	CB-2022	1
7-9	ML667675	Head Table Arm, w/pin A,B	CB-1026	1
7-10	ZW290283	'U' Ring 2.85M	6-1-1	6
7-11x	MH667506	Head Table Arm Prop	CB-1004	1
MECHA FRAME BLOCK				
7-12	MH667517	Motor Prop	CB-1005	3
7-13x	ZS421806	Screw, pan head 3x8		3
7-14	TC642273	Eject Slot	CA-2052	1
7-15	TC667653	Eject Key	CB-1024	1
7-16	SK631304	Push Button Knob I	91-5051	1
7-17x	ZS325495	Tapping Screw #2 3x6 (BR)		10
7-18	TC694697	Eject Lever Table B, w/shaft	CB-1015	1
7-19	ML693325	Eject Lever D, w/pin	CI-1009	1
7-20	ML690232	Cancellation Lever (New)	CI-1002	1
7-21	ML641698	Cancellation Lever (Old)	CA-1037	1
7-22	TC641700	Eject Lever Pillow	CA-1038	1
7-23	MH644646	Eject Lever Pin	CA-1036	1
7-24	ML693281	Spring Lever, w/pin	CI-1004	1
7-25x	ZG314818	D Lever Spring	MR-114	1
7-26	TC690221	Lock Plate Table	CI-1001	1
7-27	TC221916	Lock Plate B, w/pin (2)	CB-1060	1
7-28	MR221927	Roller	CB-1059	1
7-29	TC667585	M SW. Table B	CB-1013	1
7-30	ES494188	Micro SW. SS-5GL-13	25-1-25	1
7-31	ZS487091	Screw, pan head 2.3x8		2

8 P.C BOARDS

(1) PRE AMP P.C BOARD (CA-5205) BLOCK

Symbol No.	Parts No.	Description	Q'ty
(1)-1	BA671523	Pre Amp P.C Board Comp. (CA-5205)	1
(1)-IC1	EI669655	IC μ PC1024H	2
(1)-IC2	EI669666	IC μ PC1023H	2
(1)-IC3	EI669655	IC μ PC1024H	2
(1)-IC4	EI669712	IC TA7122AP	2
(1)-TR1	ET669633	FET Transistor 2SK68A (L) (M)	2
(1)-TR2,3	ET459810	Transistor 2SC1222 (E)(F)	4
(1)-TR4,5	ET234854	Transistor 2SC458LG (C)	4
(1)-TR6to8	ET398711	Transistor 2SC945L (Q) (R)	6
(1)-TR9	ET645917	FET Transistor 2SK30A (D)	2
(1)-TR10,11	ET234854	Transistor 2SC458LG (C)	4
(1)-TR12,13	ET398711	Transistor 2SC945L (Q) (R)	4
(1)-TR14	ET645917	FET Transistor 2SK30A (D)	2
(1)-D1	ED557447	Silicon Diode 1S1588	2
(1)-D2	ED219464	Germanium Diode 1N34A	2
(1)-D3,4	ED560913	Silicon Diode 1S2473VE	4
(1)-D5	ED491130	Zener Diode WZ-085	2
(1)-D6	ED219464	Germanium Diode 1N34A	2
(1)-D7to10	ED560913	Silicon Diode 1S2473VE	8
(1)-D11	ED624903	Silicon Diode 1S2473	2
(1)-D12	ED219464	Germanium Diode 1N34A	2
(1)-D13,14	ED560913	Silicon Diode 1S2473VE	4
(1)-D15	ED219464	Germanium Diode 1N34A	2
(1)-L1	EO496350	Inductor 146LY 36MH (J)	2
(1)-L2,3	EO308395	Ferri Inductor FL7H 3MH (J)	4
(1)-L4	EO368403	Ferri Inductor FL9H 33MH (J)	2
(1)-VR1	EV523620	Semi-fixed/Vol. V8K4-1 500 ohms B	2
(1)-VR2	EV464220	Semi-fixed/Vol. V8K4-1 50 k Ω	2
(1)-VR3	EV464207	Semi-fixed/Vol. V8K4-1 5 k Ω	2
(1)-VR4	EV464220	Semi-fixed/Vol. V8K4-1 50 k Ω	2
(1)-VR5	EV464207	Semi-fixed/Vol. V8K4-1 5 k Ω	2
(1)-FL1	ER669734	MPX Filter FB1801M	2
		Capacitor, Vertical Type	
(1)-C1	EC516723	Styrol 270PF (K) 50WV	2
(1)-C4	EC516767	Styrol 470PF (K) 50WV	2
(1)-C9,10	EC604102	Solid Aluminium 0.33 μ F (K) 25WV	2
(1)-C22	EC604102	Solid Aluminium 0.33 μ F (K) 25WV	2
(1)-C23	EC619650	Solid Aluminium 0.1 μ F (K) 25WV	2
(1)-C26,27	EC619650	Solid Aluminium 0.1 μ F (K) 25WV	4
(1)-C34	EC619650	Solid Aluminium 0.1 μ F (K) 25WV	2
(1)-C45	EC619650	Solid Aluminium 0.1 μ F (K) 25WV	2
(1)-C59	EC516778	Styrol 680PF (K) 50WV	2
(1)-C60,61	EC623002	Styrol 820PF (K) 50WV	4
(1)-C62	EC604102	Solid Aluminium 0.33 μ F (K) 25WV	2
(1)-C63	EC619650	Solid Aluminium 0.1 μ F (K) 25WV	2
(1)-C64	EC662308	Solid Aluminium 0.15 μ F (K) 25WV	2
(1)-C66,67	EC619650	Solid Aluminium 0.1 μ F (K) 25WV	4
(1)-C74	EC619650	Solid Aluminium 0.1 μ F (K) 25WV	2
(1)-C79	EC516767	Styrol 470PF (K) 50WV	2
(1)-C82	EC516767	Styrol 470PF (K) 50WV	2
(1)-C85	EC676754	Styrol 680PF (J) 50WV	2

(2) POWER SUPPLY & OSC

P.C BOARD (CB-5002) BLOCK

Symbol No.	Parts No.	Description	Q'ty
(2)-1	BA670331	Power Supply & OSC P.C Board Comp. (CB-5002)	1
(2)-TR1,2	ET622080	Transistor 2SC1175 (E) (F)	2
(2)-D2to5	ED494583	Silicon Diode 10D05	4
(2)-D6,7	ED511918	Zener Diode WZ-240	2
(2)-D8	ED560913	Silicon Diode 1S2473VE	1
(2)-T1	EO620482	OSC Coil OT-925	1
(2)-L1	EO464668	Ferri Inductor FL9H 470 μ H (K)	1
(2)-VR1,2	EV650891	Semi-fixed/Vol. V10K8-4-2 50 k Ω	2
(2)-C5	EC460091	Plastic Film/C. 3300PF (J) 500WV	1
(2)-C6,7	EC663715	Styrol/C. 820PF (J) 50WV (Vert. Type)	2

(3) PEAK METER P.C BOARD (CB-5031)

BLOCK

Symbol No.	Parts No.	Description	Q'ty
(3)-1	BA680027	Peak Meter P.C Board Comp. (CB-5031)	1
(3)-TR1to6	ET398711	Transistor 2SC945L (Q) (R)	12
(3)-D1to4	ED560913	Silicon Diode 1S2473VE	8
(3)-VR1	EV520806	Semi-fixed/Vol. V8K4-1 10 k Ω	2
(3)-VR2	EV522797	Semi-fixed/Vol. V8K4-1 20 k Ω	2
(3)-T1	BT490702	Headphone Trans. N19-349S	2
(3)-SW1	ES684448	Push SW. UEG-42N	1
(3)-2	TC668013	SW. Bracket B	1
(3)-3	ZS592378	Screw, pan head 2.6x3	2
(3)-C7	EC675178	Solid Aluminium/C. 0.47 μ F (K) 25WV (Vert. Type)	2
(3)-C8	EC619650	Solid Aluminium/C. 0.1 μ F (K) 25WV (Vert. Type)	2

(4) SW. P.C BOARD (CB-2001) BLOCK

Symbol No.	Parts No.	Description	Q'ty
(4)-1	BA210745	SW. P.C Board Comp. (CB-2001)	1
(4)-TR1,2	ET398711	Transistor 2SC945L (Q) (R)	2
(4)-TR3	ET638504	Transistor 2SC945L (P)	1
(4)-L1,2	EO243988	Ferri Inductor FL7H 3.3 MH (J)	2
(4)-SW1	ES551171	Push SW. 1FS-2U-12	1
(4)-SW2	ES666696	Push SW. 5FT-0005DF1320	1
(4)-2	MZ222930	SW. Mt. Table B	1
(4)-3	ZS422076	Screw, Pan head 3x5	4
(4)-C14	EC514001	Styrol/C. 390PF (J) 50WV (Vert. Type)	1

(5) RELAY P.C BOARD (CB-5001) BLOCK

Symbol No.	Parts No.	Description	Q'ty
(5)-1	BA670274	Relay P.C Board Comp. (CB-5001)	1
(5)-D1,2	ED560913	Silicon Diode 1S2473VE	2
(5)-RL1	EP621808	Relay MTS-2	1

When ordering parts, Please describe Parts Number, Serial Number, and Model Number in detail.

(6) SYS. CON P.C BOARD (CB-5004) BLOCK

Symbol No.	Parts No.	Description	Q'ty
(6)-1	BA670263	Sys. Con P.C Board Comp. (CB-5004)	1
(6)-TR1,2	ET666415	Transistor 2SB605 (K) (L)	2
(6)-TR3	ET398711	Transistor 2SC945L (Q) (R)	1
(6)-TR4	ET517375	Transistor 2SD360 (D) (E)	1
(6)-TR5	ET666404	Transistor 2SD571 (K) (L)	1
(6)-TR7	ET666404	Transistor 2SD571 (K) (L)	1
(6)-TR8	ET557976	Transistor 2SA628 (E) (F)	1
(6)-TR9,10	ET398711	Transistor 2SC945L (Q) (R)	2
(6)-TR11	ET557976	Transistor 2SA628 (E) (F)	1
(6)-TR12	ET666404	Transistor 2SC571 (K) (L)	1
(6)-TR13to21	ET398711	Transistor 2SC945L (Q) (R)	9
(6)-TR22	ET666393	Transistor 2SC1211 (E) (F)	1
(6)-TR23	ET398711	Transistor 2SC945L (Q) (R)	1
(6)-TR24	ET666404	Transistor 2SC571 (K) (L)	1
(6)-TR25to34	ET398711	Transistor 2SC945L (Q) (R)	10
(6)-TR35	ET666707	Transistor 2SD401 (K) (L)	1
(6)-D1to5	ED560913	Silicon Diode 1S2473VE	4
(6)-D6,7	ED219464	Germanium Diode 1N34A	2
(6)-D8,9	ED624903	Silicon Diode 1S2473	2
(6)-D10,11	ED560913	Silicon Diode 1S2473VE	2
(6)-D12	ED624903	Silicon Diode 1S2473	1
(6)-D13	ED560913	Silicon Diode 1S2473VE	1
(6)-D14,15	ED624903	Silicon Diode 1S2473	2
(6)-D16,17	ED560913	Silicon Diode 1S2473VE	2
(6)-D18	ED624903	Silicon Diode 1S2473	1
(6)-D19to21	ED560913	Silicon Diode 1S2473VE	3
(6)-D22to24	ED624903	Silicon Diode 1S2473	3
(6)-D25	ED560913	Silicon Diode 1S2473VE	1
(6)-D26	ED624903	Silicon Diode 1S2473	1
(6)-D27	ED560913	Silicon Diode 1S2473VE	1
(6)-D28,29	ED624903	Silicon Diode 1S2473	2
(6)-D30,31	ED560913	Silicon Diode 1S2473VE	2
(6)-D32	ED624903	Silicon Diode 1S2473	1
(6)-D33	ED560913	Silicon Diode 1S2473VE	1
(6)-D34	ED624903	Silicon Diode 1S2473	1
(6)-D35	ED560913	Silicon Diode 1S2473VE	1
(6)-D36to39	ED624903	Silicon Diode 1S2473	4
(6)-D40	ED560913	Silicon Diode 1S2473VE	1
(6)-D41	ED624903	Silicon Diode 1S2473	1
(6)-D42,43	ED560913	Silicon Diode 1S2473VE	2
(6)-D44	ED624903	Silicon Diode 1S2473	1
(6)-D45to47	ED560913	Silicon Diode 1S2473VE	3
(6)-D48	ED624903	Silicon Diode 1S2473	1
(6)-D49	ED560913	Silicon Diode 1S2473VE	1
(6)-D50to52	ED624903	Silicon Diode 1S2473	3
(6)-D53,54	ED560913	Silicon Diode 1S2473VE	2
(6)-D55,56	ED624903	Silicon Diode 1S2473	2
(6)-D57	ED560913	Silicon Diode 1S2473VE	1
(6)-D58,59	ED624903	Silicon Diode 1S2473	2
(6)-D60	ED560913	Silicon Diode 1S2473VE	1
(6)-D61to65	ED624903	Silicon Diode 1S2473	5
(6)-D66	ED560913	Silicon Diode 1S2473VE	1
(6)-D67to71	ED624903	Silicon Diode 1S2473	5
(6)-D72	ED560913	Silicon Diode 1S2473VE	1
(6)-D73to75	ED624903	Silicon Diode 1S2473	3
(6)-D76to79	ED224550	Silicon Diode 10D4	4
(6)-D80to84	ED560913	Silicon Diode 1S2473VE	5
(6)-D85	ED219464	Germanium Diode 1N34A	1
(6)-TH1	ED650968	Thermister (Sine) PTH62AR 100M	1
(6)-RL1	EP616500	Relay LC1-C-JT DC24V	1
(6)-2	MZ668035	Heat-sink Plate B	1
(6)-3	ZS421806	Screw, pan head 3x8	1
(6)-4	ZW273756	Nut M3	1
(6)-R45	ER389507	Metal Oxide Film/R. 2W 430 ohms (K)	1
(6)-R111	ER563253	Cement/R. 3W 2.2 ohms (K) (Wire-wound Type)	1

(7) SERVO P.C BOARD (CB-2025) BLOCK

Symbol No.	Parts No.	Description	Q'ty
(7)-1	BA670252	Servo P.C Board Comp. (CB-2025)	1
(7)-TR1to6	ET592424	Transistor 2SC1647 (S) (E)	6
(7)-D1to4	ED224548	Silicon Diode 10D2	4
(7)-D5	ED560913	Silicon Diode 1S2473VE	1
(7)-L1	EO538391	Ferri Inductor FL11H 100MH (J)	1
(7)-VR1	EV620493	Semi-fixed/Vol. V8K4-1 3 kB	1
(7)-2	EZ659867	Heat-sink Plate	1
(7)-3	ZS421806	Screw, pan head 3x8	1
(7)-4	ZW273756	Nut M3	1
(7)-5	ZS558101	Screw, pan head 3x6 w/washer	2
(7)-C1	EC487157	NP/C. 0.47μF (M) 50WV (Vert. Type)	1

(8) NOISE FILTER P.C BOARD (CB-2027) BLOCK

Symbol No.	Parts No.	Description	Q'ty
(8)-1	BA670230	Noise Filter P.C Board Comp. (CB-2027)	1
(8)-T1to4	EO669273	Inductor FL5R-200	4
(8)-2	MZ669251	P.C Board Holder D	1
(8)-3	ZS558101	Screw, pan head 3x6 w/washer	1

(9) STOP DETECTION P.C BOARD (CB-2026) BLOCK

Symbol No.	Parts No.	Description	Q'ty
(9)-1	BA670195	Stop Detection P.C Board Comp. (CB-2026)	1
(9)-IC1	EI620640	IC DN835	1
(9)-TR1	ET638504	Transistor 2SC945L (P)	1
(9)-2	TC613541	IC Retainer	1

(10) LAMP P.C BOARD (CB-2002) BLOCK

Symbol No.	Parts No.	Description	Q'ty
(10)-1	BA670217	Lamp P.C Board Comp. (CB-2002)	1
(10)-L1to5	EL619064	Lamp (L/T) 24V 35MA	5

(11) PROTECTION P.C BOARD (CB-5028) BLOCK (CSA)

Symbol No.	Parts No.	Description	Q'ty
(11)-1	BA671207	Protection P.C Board Comp. (CB-5028)	1
(11)-TR1	ET666707	Transistor 2SD401 (K) (L)	1

9 ILLUSTRATION OF POWER SUPPLY CHASSIS BLOCK

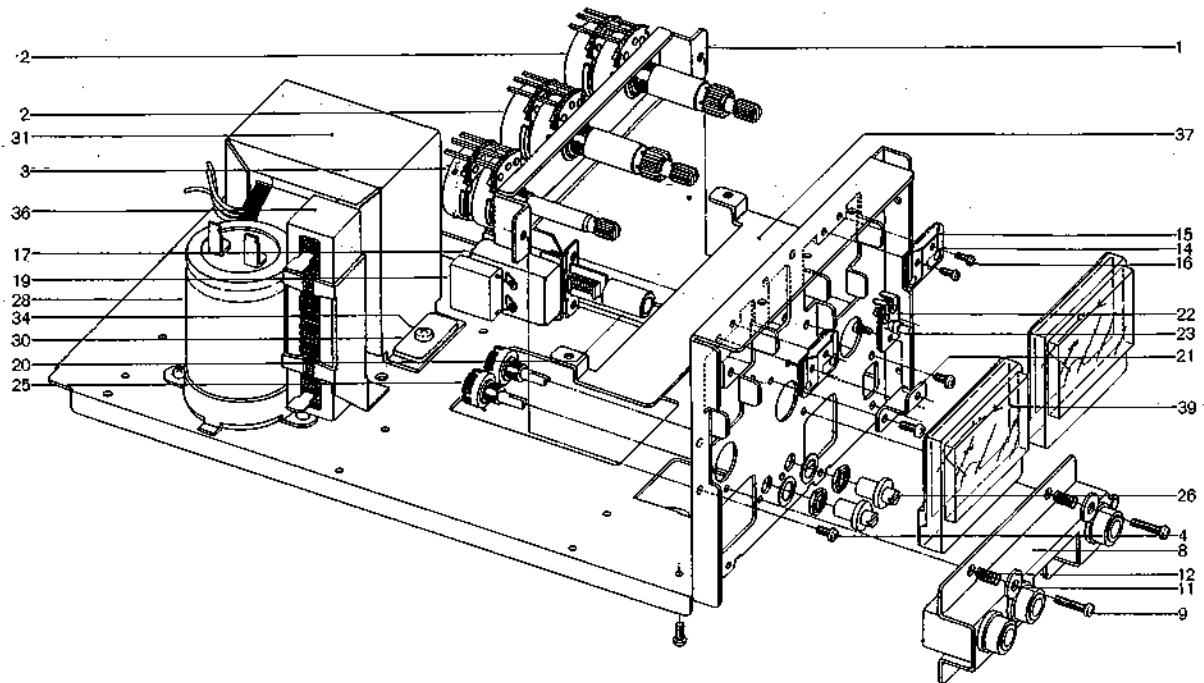

9) POWER SUPPLY CHASSIS BLOCK

Ref. No.	Parts No.	Description	Schematic No.	Q'ty	Ref. No.	Parts No.	Description	Schematic No.	Q'ty
9-1	TC668002	Vol. Mt. Base	CB-5015	1	9-23	ED656346	Luminous Diode SEL-305GC	45-15-10	1
9-2	EV669756	2-axial 2-throw Vol. V24L5DWTN 50 kAx2	36-3-67	2	9-24x	ZW259503	Washer (Nylon) D3.1x8x0.5t		1
9-3	EV645851	Co-axial 2-throw Vol. GJ10E 10 kBx2	36-1-40	1	9-25	EV669868	Vol. V12M4-1N15 FH 5 kB	36-7-13	2
9-4	ZS422076	Screw, pan head 3x5		8	9-26	SK669971	Rec. Cal Knob	CA-5203	2
9-5x	BA680027	Peak Meter P.C Board Comp.	CB-5031	1	9-27x	TR533564	Screw, pan head (w/flange)	ED-6006	1
9-6x	SZ645221	Memory Cap	CA-6010	1	9-28	EC684472	Elect./C. (wrapping type) 330µF 160WV	24-10-708	1
9-7	ZS379350	Screw, pan head 3x6		4	9-29x	EZ624047	Cord Retainer	2-7-48	1
9-8	EJ645827	3-throw Jack B	31-2-70	1	9-30	EZ486617	Trans. Reinforcement Plate B	LF-5222	2
9-9	ZS447805	Tapping Screw L2 3x12 (BR)		2	9-31	BT666718	Power Trans. CBT-1	38-4-391	1
9-10x	TC676844	Spacer 3x6	7-2-6	2	9-32x	BT666731	Power Trans. CBT-3 (CEE)	38-4-393	1
9-11	ZW620627	Washer (SPC) D4.2x11x0.8t		2	9-33x	BT666720	Power Trans. CBT-2 (CSA, JPN)	38-4-392	1
9-12	ZG580533	Cramp Spring	TD-2046	2	9-34	ZW413177	Screw, pan head 4x10 w/washer		2
9-13x	TC666134	Illumination for Acrylic	CA-5019	1	9-35x	ZW413188	Nut M4		2
9-14	EA457176	Lamp P.C Board	CG-5003	2	9-36	ER666775	Cement/R. (Wire-wound type) 30W 650 ohms (K)	35-16-62	1
9-15	EL295312	Lamp (L/T) 8V 0.2A	28-2-8	2	9-37	TC669025	P.C Board Bracket	CB-5027	1
9-16	ZS499331	Screw, pan head 2.3x5		4	9-38x	ZW321513	Washer (Nylon) D2.6x8x1t		2
9-17	ES479395	Push SW. TV-3 JH5	25-5-62	1					
9-18x	ES499972	Push SW. JS-09 (CEE)	25-5-67	1					
9-19	EC551160	Ceramic/C. NB821YZ 0.01µF(Z) 1.4 kWV	24-5-55	2	9-39	EM684450	VU Meter KL-243S-30	46-1-123	2
9-20	SK631304	Push Button Knob I	91-5051	1	9-40x	EM684461	VU Meter KL-243S-31 (JPN)	46-1-122	2
9-21	TC644343	P.C Board Mount B	CA-5011	1					
9-22	EA647188	LED P.C Board	CA-2051	1					

When ordering parts, Please describe Parts Number, Serial Number, and Model Number in detail.

10 ILLUSTRATION OF AMP ASSEMBLY BLOCK

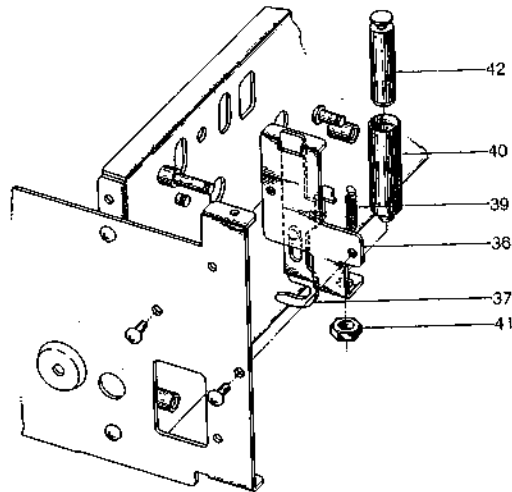
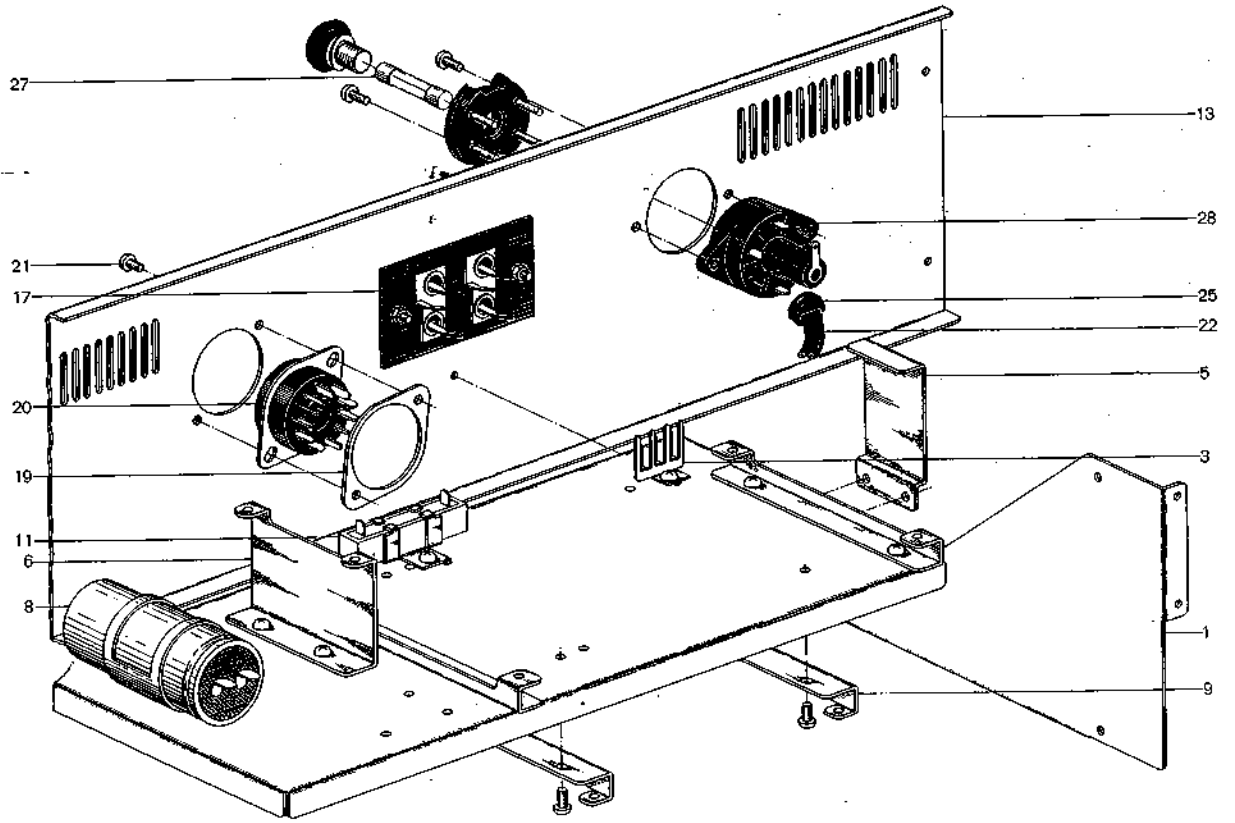

10) AMP ASSEMBLY BLOCK

Ref. No.	Parts No.	Description	Schematic No.	Qty
AMP CHASSIS BLOCK				
10-1	TC668114	Center Angle	CB-5007	1
10-2x	ZS325495	Tapping Screw #2 3x6 (BR)		3
10-3	EJ551035	Wrapping Terminal, 4P		
		T-5251	32-1-36	1
10-4x	EZ624047	Cord Retainer	2-7-48	3
10-5	TC676855	Variar	CB-5029	1
10-6	TC668046	Servo P.C Board Support.	CB-5020	1
10-7x	TC667967	P.C Board Support A	CB-5009	2
10-8	EC412582	MP/C. 6 μ F 150WV AC (Lug Type UNI/D.)	24-9-55	1
10-9	TC667978	P.C Board Support B	CB-5010	3
10-10x	TC667980	P.C Board Support C	CB-5011	1
10-11	ER666764	Cement/R. 10W 40+40 ohms (K)	35-16-22	1
10-12x	MT553948	Wire Band B-100	2-35-3	6
REAR CHASSIS BLOCK				
10-13	SP666437	Rear Panel A	CB-5018	1
10-14x	SP668237	Rear Panel E	CB-5018	1
10-15x	SP668215	Rear Panel C	CB-5018	1
10-16x	SP668204	Rear Panel B	CB-5018	1
10-17	EJ669745	4P Jack Plate	31-5-130	1
10-18x	HZ372161	Hollow Rivet 3x4.5		2
10-19	MZ302400	Remote Control Socket Mt. Plate	RX-515	1
10-20	EJ222748	Socket, sub magnale #311SG	31-1-39	1
10-21	ZS201150	Screw, truss head 3x6 (Black)		2
10-22	EW374894	AC Cord CUL 3M	26-3-19	1
10-23x	EW516600	AC Cord (CEE) VM-0065	26-3-28	1
10-24x	EW524845	AC Cord (J) 2.5M	26-3-31	1
10-25	EJ631945	Strain Relief SR-4N-4	2-7-49	1
10-26x	EZ246936	Strain Relief SR-6W-1 (WG, 3 core)	2-7-8	1
10-27	EF590692	Fuse 1.2A 250V	39-1-51	1
10-28	EJ233370	Volt. Selector S-18010	40-2-3	1
10-29x	TC668024	Fuse Base (CEE, CSA, JPN)	CB-5017	1
10-30x	EJ666753	2P Fuse Holder (small) (CEE)	40-1-91	1
10-31x	EJ666742	2P Fuse Holder (large) (CSA, JPN)	40-1-90	1
10-32x	EF593706	Fuse (Semko T Type) 500 MAT (CEE)	39-1-53	1
10-33x	EF623103	Fuse (Semko T Type) 1 AT (CEE)	39-1-53	1
10-34x	EF668610	Fuse ULMF61M 250V 1.2A (CSA)	39-1-45	2
DAMPER BLOCK				
10-35	EZ681941	Damper Block Comp.	CB	1
10-36	MZ203872	Cylinder Mt. Plate, w/pin 3	CB-1053	1
10-37	ML203861	Slide Lever	CB-1054	1
10-38x	ZW290294	'U' Ring 2.85M	6-1-1B	1
10-39	ZG366761	Spring, Slider D	RCC-1209	1
10-40	TC691187	Cylinder	CI-6009	1
10-41	ZW413278	Nut M5		1
10-42	MH691198	Damp Pin	CI-6010	1

When ordering parts, Please describe Parts Number, Serial Number, and Model Number in detail.

11 PHOTO OF FINAL ASSEMBLY BLOCK

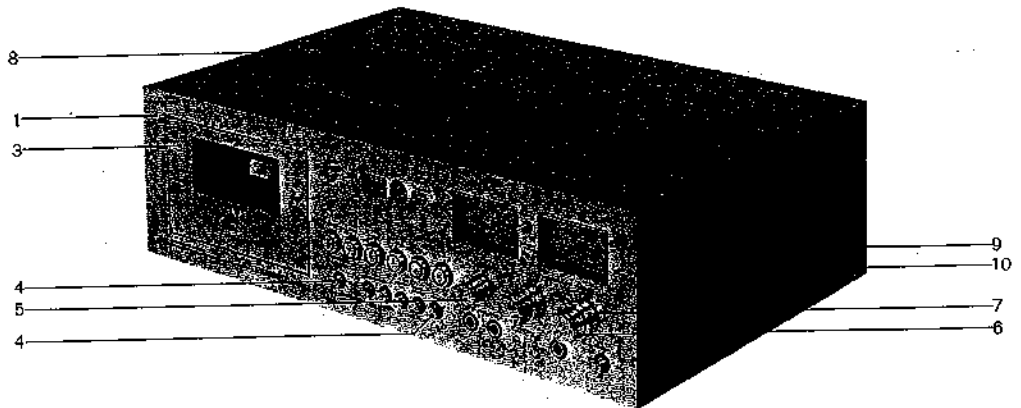

11) FINAL ASSEMBLY BLOCK

Ref. No.	Parts No.	Description	Schematic No.	Q'ty
11-1	BD681974	Front Panel Block Comp.	CB	1
11-2x	ZS325495	Tapping Screw #2 3x6 (BR)		6
11-3	BD681491	Lid Panel Block Comp.	CA2,CB	1
11-4	SK634410	Push Button Knob J	91-5051	6
11-5	SK645030	Single Knob B	CA-6013	1
11-6	SK669993	Double Knob (Upper)	CA-6201	2
11-7	SK654750	Double Knob (Lower)	CA-6202	2
11-8	BC647076	Cabinet	CA-6008	1
11-9	ZW548010	Spot Facing Washer	MU-6028	4
11-10	ZSS10344	Screw, binding head 4x12		4
11-11x	SP647054	Bottom Plate	CA-6009	1
11-12x	SZ645243	Circular Foot, A, w/rubber A	CA-6014	4
11-13x	ZS417150	Screw, pan head 4x6		4
11-14x	MT553948	Wire Band B-100	2-35-3	7

12 LIST OF INTERCHANGEABLE SEMICONDUCTORS

As far as service in concerned, in case the original parts cannot be obtained, the interchangeable parts listed below can be substituted.

Original Parts			Interchangeable Parts	
Description	Parts No.	Utilizing P.C Board	Description	Parts No.
2SC458LG (C)	ET234854	CA-5205	2SC693U (F) 2SC458 (C) 2SC1312S (G) (H)	ET315472 ET329218 ET603257
2SC945L (Q) (R)	ET398711	CA-5205 CB-5031 CB-2001 CB-5004 CB-2026	2SC711 (E) (F) 2SC1647 (R) (S) (E) 2SC1641 (R) (S) (E)	ET453486 ET623733 ET603843
2SC945L (P)	ET638504			
2SC1175 (E) (F)	ET622080	CB-5002	2SC1211 (E) (F)	ET666393
2SC1211 (E) (F)	ET666393	CB-5004	2SC1175 (E) (F) 2SC1247A (B) (V)	ET622080 ET511920
2SC1222 (E) (F)	ET469810	CA-5205	2SC458LG (C) 2SC1000GR (BL)	ET234854 ET622181
2SC1647 (S) (E)	ET592424	CB-2025	2SC945L (K) (P) (Q) 2SC536 (F) (G) (H)	ET632204 ET632215
2SC1683 (P) (Q)	ET635826	CB-5002	T1P47 T1P48	ET621775 ET621786
2SA628 (E) (F)	ET557976	CB-5004	2SA564 (Q) (R) 2SA733 (P) (Q)	ET538154 ET554657
2SB360 (D) (E)	ET517375	CB-5004	2SD325 (D) (E) 2SC1098 (L) (K)	ET631855 ET465208
2SB605 (K) (L)	ET666415	CB-5004		
2SD361 (D) (E)	ET537300	CB-5002	2SC1098 (L) (M)	ET476886
2SD401 (K) (L)	ET666707	CB-5004 CB-5028		
2SD571 (K) (L)	ET666404	CB-5004		
T1P47	ET621775	CB-2025	T1P48 2SC1683 (P) (Q)	ET621786 ET635826
2SK30A (O) 2SK68A (L) (M)	ET550798 ET669633	CA-5205 CA-5205	2SK34 (D)	ET603270
μPC1023H	EI669666	CA-5205	TA7122P	EI669712
μPC1024H	EI669655	CA-5205	TA7129P	EI657000
DN-831	EI620640	CB-2026		
1N34A	ED219464	CA-5205	1S188AM 1N60	ED562386 ED428264
1S2473	ED624903	CA-5205 CB-5004	1S1588	ED557447
1S2473VE	ED560913	CA-5205 CB-5031 CB-5002 CB-5001 CB-5004 CB-2025	WG599 1S1588 WG713	ED514721 ED557447 ED515790

Original Parts			Interchangeable Parts	
Description	Parts No.	Utilizing P.C Board	Description	Parts No.
IS1588	ED557447	CA-5205	1S2473 WG599	ED624903 ED514721
10D05	ED494583	CB-5002	1N4001	ED538615
10D2	ED224548	CB-2025	1N4003	ED570295
10D4	ED224550	CB-5004	1N4004	ED570273
WZ085	ED491130	CA-5205	RD9A	ED384096
WZ240	ED511918	CB-5002	RD24A	ED229072
SEL305GC	ED656346			

INDEX

Parts No.	Ref. No. & Symbol No.	Parts No.	Ref. No. & Symbol No.	Parts No.	Ref. No. & Symbol No.	Parts No.	Ref. No. & Symbol No.	Parts No.	Ref. No. & Symbol No.
BA210745	(4)-1	ED557447	(1)-D1	EO669273	(8)-T1to4	MH533913	7-5	TC666156	5-18
BA670195	(9)-1	ED560913	(1)-D3,4	EP537906	7-2	MH644646	7-23	TC667416	1-42
BA670217	4-10	ED560913	(1)-D7to10	EP616500	(6)-RL1	MH644916	5-25	TC667427	1-44
BA670217	(10)-1	ED560913	(1)-D13,14	EP621808	(5)-RL1	MH664064	5-17	TC667438	1-52
BA670230	(8)-1	ED560913	(2)-D8	ER389507	(6)-R45	MH667506	6-6	TC667451	1-47
BA670252	(7)-1	ED560913	(3)-D1to4	ER563253	(6)-R111	MH667506	7-11x	TC667574	6-16
BA670263	(6)-1	ED560913	(5)-D1,2	ER666764	10-11	MH667517	7-12	TC667585	7-29
BA670274	(5)-1	ED560913	(6)-D1to5	ER666775	9-36	MH691198	10-42	TC667620	2-5
BA670331	(2)-1	ED560913	(6)-D10,11	ER669734	(1)-FL1	ML203861	10-37	TC667642	6-27
BA671207	(11)-1	ED560913	(6)-D13	ES477966	6-17	ML595574	5-5	TC667653	7-15
BA671523	(1)-1	ED560913	(6)-D16,17	ES479395	9-17	ML595585	5-6	TC667721	6-23
BA680027	(3)-1	ED560913	(6)-D19to21	ES494188	7-30	ML641621	1-8	TC667945	7-8
BA680027	9-5x	ED560913	(6)-D25	ES499972	9-18x	ML641632	1-9	TC667956	7-1
BC647076	11-8	ED560913	(6)-D27	ES551171	(4)-SW1	ML641698	7-21x	TC667967	10-7
BD681491	11-3	ED560913	(6)-D30,31	ES619053	6-24	ML645063	1-6	TC667978	10-9
BD681974	11-1	ED560913	(6)-D33	ES666685	4-12	ML667462	6-14	TC667980	10-10
BF667618	2-6	ED560913	(6)-D35	ES666696	(4)-SW2	ML667528	6-30	TC668002	9-1
BF668790	2-7	ED560913	(6)-D40	ES684448	(3)-SW1	ML667675	7-9	TC668013	(3)-2
BH671174	1-37	ED560913	(6)-D42,43	ET234854	(1)-TR4,5	ML690232	7-20	TC668024	10-29x
BM670138	2-2	ED560913	(6)-D45to47	ET234854	(1)-TR10,11	ML693281	7-24	TC668046	10-6
BM670140	2-1	ED560913	(6)-D49	ET398711	(1)-TR6to8	ML693325	7-19	TC668092	1-41
BM670151	3-1	ED560913	(6)-D53,54	ET398711	(1)-TR12,13	ML699412	5-21	TC668114	10-1
BM670162	3-2	ED560913	(6)-D57	ET398711	(3)-TR1to6	MP612628	1-13	TC668125	4-1
BR670173	2-3	ED560913	(6)-D60	ET398711	(4)-TR1,2	MR203804	5-22	TC669025	9-37
BT490702	(3)-T1	ED560913	(6)-D66	ET398711	(6)-TR3	MR221927	7-28	TC676844	9-10
BT666718	9-31	ED560913	(6)-D72	ET398711	(6)-TR9,10	MR668068	3-6	TC676855	10-5
BT666720	9-33x	ED560913	(6)-D80to84	ET398711	(6)-TR13to21	MS227136	1-4	TC690221	7-26
BT666731	9-32x	ED560913	(7)-D5	ET398711	(6)-TR23	MS595552	5-4	TC690412	6-12
BZ211105	1-1x	ED624903	(1)-D11	ET398711	(6)-TR25to34	MS595563	5-3	TC691187	10-40
BZ651240	6-26x	ED624903	(6)-D8,9	ET459810	(1)-TR2,3	MS642374	5-29	TC693303	6-9
BZ667844	4-2	ED624903	(6)-D12	ET517375	(6)-TR4	MS645153	1-53	TC694697	7-18
BZ667855	4-3	ED624903	(6)-D14,15	ET557976	(6)-TR8	MS659902	1-26	TR533564	9-27x
BZ667866	4-4	ED624903	(6)-D18	ET557976	(6)-TR11	MS659913	1-25	ZG207257	5-13
BZ667877	4-5	ED624903	(6)-D22to24	ET592424	(7)-TR1to6	MS667473	1-43	ZG217337	6-13
BZ667888	4-6	ED624903	(6)-D26	ET622080	(2)-TR1,2	MT553948	6-28x	ZG224796	6-11
BZ681917	6-1x	ED624903	(6)-D28,29	ET638504	(4)-TR3	MT553948	10-12	ZG227114	1-23x
BZ699996	6-21	ED624903	(6)-D32	ET638504	(9)-TR1	MT553948	11-14	ZG227452	5-27
EA457176	9-14	ED624903	(6)-D34	ET645917	(1)-TR9	MV522235	1-54	ZG314818	7-25x
EA647188	9-22	ED624903	(6)-D36to39	ET645917	(1)-TR14	MV666887	2-8	ZG359638	6-15
EA647190	6-3	ED624903	(6)-D41	ET666393	(6)-TR22	MZ203815	5-24	ZG366761	10-39
EA669510	1-40x	ED624903	(6)-D44	ET666404	(6)-TR5	MZ203872	10-36	ZG386335	1-60x
EC412582	10-8	ED624903	(6)-D48	ET666404	(6)-TR7	MZ222930	(4)-2	ZG392804	6-31
EC460091	(2)-C5	ED624903	(6)-D50to52	ET666404	(6)-TR12	MZ302400	10-19	ZG465636	1-33
EC487157	(7)-C1	ED624903	(6)-D55,56	ET666404	(6)-TR24	MZ642104	1-56	ZG542215	1-45
EC514001	(4)-C14	ED624903	(6)-D58,59	ET666415	(6)-TR1,2	MZ659981	3-3	ZG569384	1-59
EC516723	(1)-C1	ED624903	(6)-D61to65	ET666707	(6)-TR35	MZ668035	(6)-2	ZG580535	9-12
EC516767	(1)-C4	ED624903	(6)-D67to71	ET666707	(11)-TR1	MZ668057	3-8	ZG595618	5-7
EC516767	(1)-C79	ED624903	(6)-D73to75	ET669633	(1)-TR1	MZ668968	3-5	ZG595620	5-8
EC516767	(1)-C82	ED650968	(6)-TH1	EV464207	(1)-VR3	MZ669251	(8)-2	ZG644411	1-14
EC516778	(1)-C59	ED656346	9-23	EV464207	(1)-VR5	SK631304	7-16	ZG659880	1-27
EC551160	9-19	EF590692	10-27	EV464220	(1)-VR2	SK631304	9-20	ZG667811	4-7
EC604102	(1)-C9,10	EF593706	10-32x	EV464220	(1)-VR4	SK634410	11-4	ZS201150	10-21
EC604102	(1)-C22	EF623103	10-33x	EV520806	(3)-VR1	SK645030	11-5	ZS303625	1-32
EC604102	(1)-C62	EF668610	10-34x	EV522797	(3)-VR2	SK654750	11-7	ZS325495	1-51
EC619650	(1)-C23	EI620640	(9)-IC1	EV523620	(1)-VR1	SK669971	9-26	ZS325495	4-9
EC619650	(1)-C26,27	EI669655	(1)-IC1	EV620493	(7)-VR1	SK669993	11-6	ZS325495	6-20
EC619650	(1)-C34	EI669655	(1)-IC3	EV645851	9-3	SP647054	11-11x	ZS325495	7-17x
EC619650	(1)-C45	EI669666	(1)-IC2	EV650891	(2)-VR1,2	SP666437	10-13	ZS325495	10-2
EC619650	(1)-C63	EI669712	(1)-IC4	EV669756	9-2	SP668204	10-16x	ZS325495	11-2x
EC619650	(1)-C66,67	EJ222748	10-20	EV669868	9-25	SP668215	10-15x	ZS356804	1-31
EC619650	(1)-C74	EJ233370	10-28	EW374894	10-22	SP668237	10-14x	ZS356804	3-7
EC619650	(3)-C8	EJ551035	10-3	EW516600	10-23x	SZ645221	6-25	ZS379350	1-39
EC623002	(1)-C60,61	EJ631945	10-25	EW524845	10-24x	SZ645221	9-6x	ZS379350	9-7
EC662308	(1)-C64	EJ645827	9-8	EZ246936	10-26x	SZ645243	11-12x	ZS379405	1-16
EC663715	(2)-C6,7	EJ666742	10-31x	EZ486617	9-30	SZ684696	4-8	ZS391522	1-34
EC675178	(3)-C7	EJ666753	10-30x	EZ624047	9-29x	TC220871	6-29	ZS414033	5-26
EC676754	(1)-C85	EJ669745	10-17	EZ614047	10-4	TC221916	7-27	ZS417150	11-13x
EC684472	9-28	EL295312	6-4	EZ659867	(7)-2	TC613541	(9)-2	ZS417161	6-5
ED219464	(1)-D2	EL295312	9-15	EZ681941	10-35	TC641700	7-22	ZS417216	1-36x
ED219464	(1)-D6	EL619064	4-11	HE636963	1-17	TC642071	5-30	ZS417216	1-57
ED219464	(1)-D12	EL619064	(10)-L1to5	HZ227103	1-18	TC642115	1-58	ZS421806	(6)-3
ED219464	(1)-D15	EM684450	9-39	HZ227158	1-2	TC642148	5-15	ZS421806	(7)-3
ED219464	(6)-D6,7	EM684461	9-40x	HZ372161	10-18x	TC642273	7-14	ZS421806	7-13x
ED219464	(6)-D85	EO243988	(4)-L1,2	HZ567202	1-61x	TC642363	6-2	ZS422076	1-55
ED224548	(7)-D1to4	EO308395	(1)-L2,3	HZ644400	1-15	TC644343	9-21	ZS422076	(4)-3
ED224550	(6)-D7to79	EO368403	(1)-L4	HZ669892	1-29	TC645186	5-12	ZS422076	7-4
ED224550	7-3x	EO464668	(2)-L1	HZ669903	1-30	TC646920	5-2	ZS422076	9-4
ED491130	(1)-D5	EO496350	(1)-L1	HZ683673	1-3x	TC646931	5-1	ZS422965	3-4
ED494583	(2)-D2to5	EO538391	(7)-L1	MB415743	6-22	TC647065	5-11	ZS447805	9-9
ED511918	(2)-D6,7	EO620482	(2)-T1	MB669036	2-10	TC666134	9-13	ZS461395	1-38

INDEX

Parts No.	Ref. No. & Symbol No.	Parts No.	Ref. No. & Symbol No.	Parts No.	Ref. No. & Symbol No.	Parts No.	Ref. No. & Symbol No.
ZS462802	4-14						
ZS464692	1-19						
ZS477876	1-20						
ZS487091	6-18						
ZS487091	7-31						
ZS499331	9-16						
ZS510344	11-10						
ZS521987	2-4						
ZS524812	1-11						
ZS558101	(7)-5						
ZS558101	(8)-3						
ZS592378	(3)-3						
ZS592402	5-16						
ZS608106	1-22x						
ZS666336	4-13						
ZS669104	5-14						
ZW222388	1-49						
ZW259503	5-23						
ZW259503	9-24x						
ZW260122	5-20x						
ZW270088	1-12						
ZW270088	5-10						
ZW270088	7-6						
ZW270101	7-7						
ZW273633	6-19x						
ZW273666	1-24x						
ZW273745	1-7x						
ZW273756	1-5x						
ZW273756	(6)-4						
ZW273756	(7)-4						
ZW290283	1-46						
ZW290283	5-19						
ZW290283	6-10						
ZW290283	7-10						
ZW290294	10-38x						
ZW321513	9-38x						
ZW322110	5-28x						
ZW364364	1-10						
ZW413177	9-34						
ZW413188	9-35x						
ZW413278	10-41						
ZW450753	1-48x						
ZW485728	1-21						
ZW548010	11-9						
ZW562476	1-35x						
ZW562476	1-50						
ZW592391	5-9						
ZW597543	2-9						
ZW620627	9-11						
ZW668452	3-9						
ZW668452	6-8						
ZW669148	1-28						
ZW675033	6-7						

SECTION 3

SCHEMATIC DIAGRAM

1. GXC-760D NO. 5-1 1521218A CONNECTION DIAGRAM
2. GXC-760D NO. 5-2 1521219A PRE AMP SCHEMATIC DIAGRAM
3. GXC-760D NO. 5-3 1521220A SYSCON SCHEMATIC DIAGRAM
4. GXC-760D NO. 5-4 1521221A PEAK METER SCHEMATIC DIAGRAM
5. GXC-760D NO. 5-5 1521222A POWER SUPPLY SCHEMATIC DIAGRAM

GXC-7600

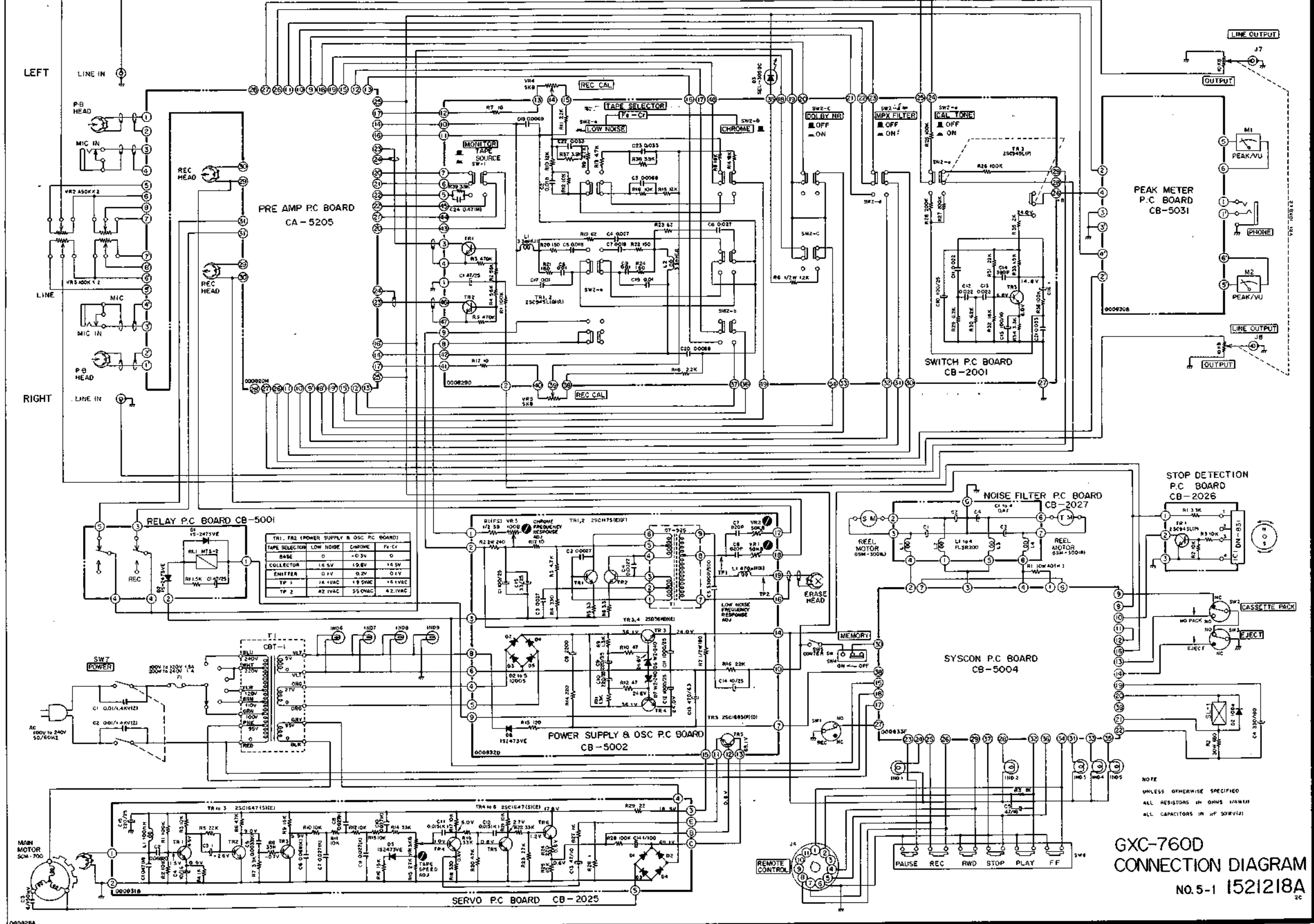

GXC-7600
CONNECTION DIAGRAM
NO.5-1 15218A

NOTE
UNLESS OTHERWISE SPECIFIED
ALL RESISTORS IN OHMS /K/W/R
ALL CAPACITORS IN μ F /M/F/D

GXC-760D

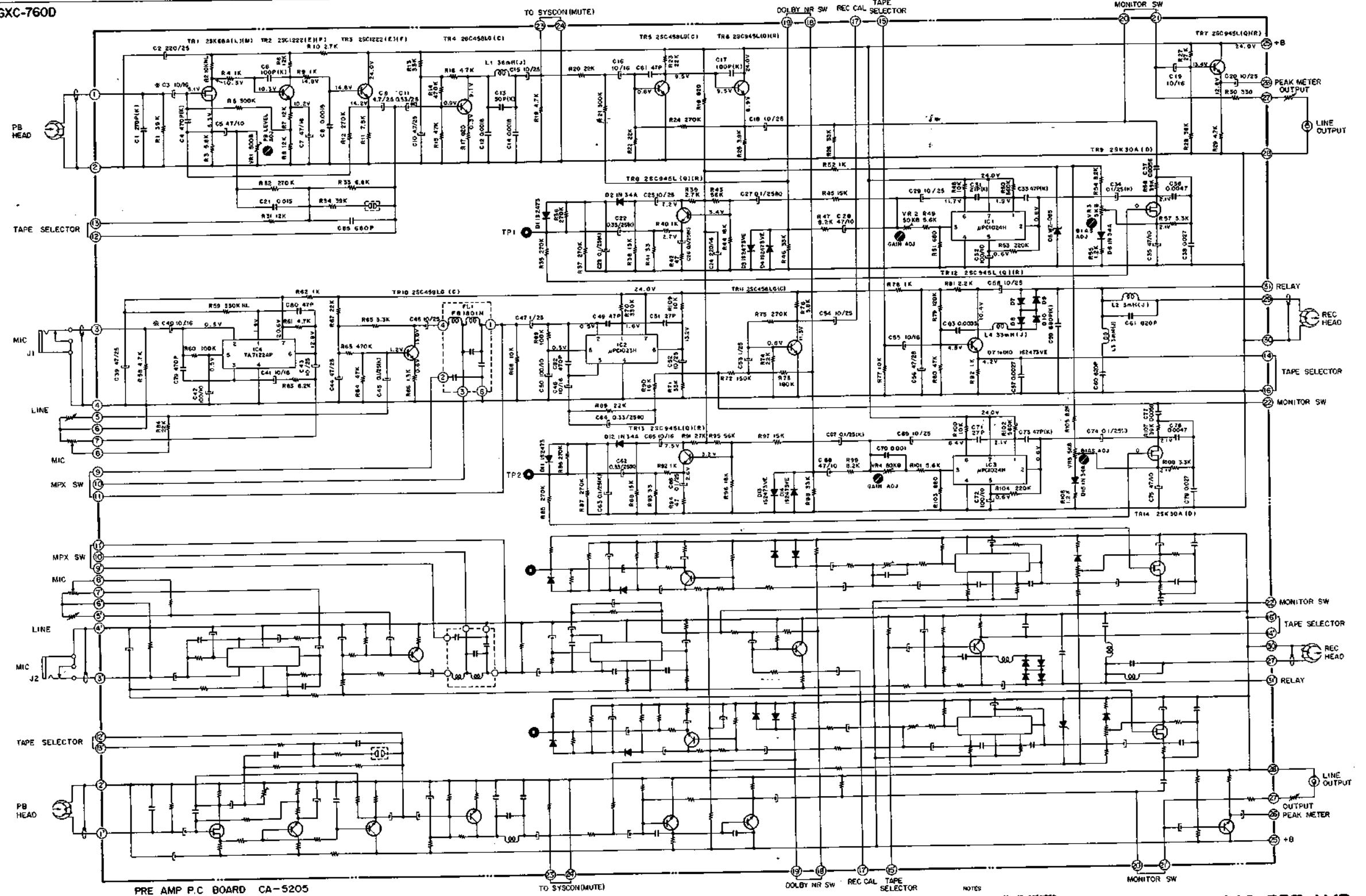

PRE AMP P.C. BOARD CA-5205

NOTES
 1. UNLESS OTHERWISE SPECIFIED
 ALL RESISTORS IN OHMS (Ω)
 ALL CAPACITORS IN μF (μF)
 2. * MARK INDICATES LOW LEAKAGE
 CAPACITORS
 3. NL INDICATES NOISE LESS RESISTORS

GXC-760D PRE AMP
 SCHEMATIC DIAGRAM
 NO.5-2 1521219A

GXC-760D

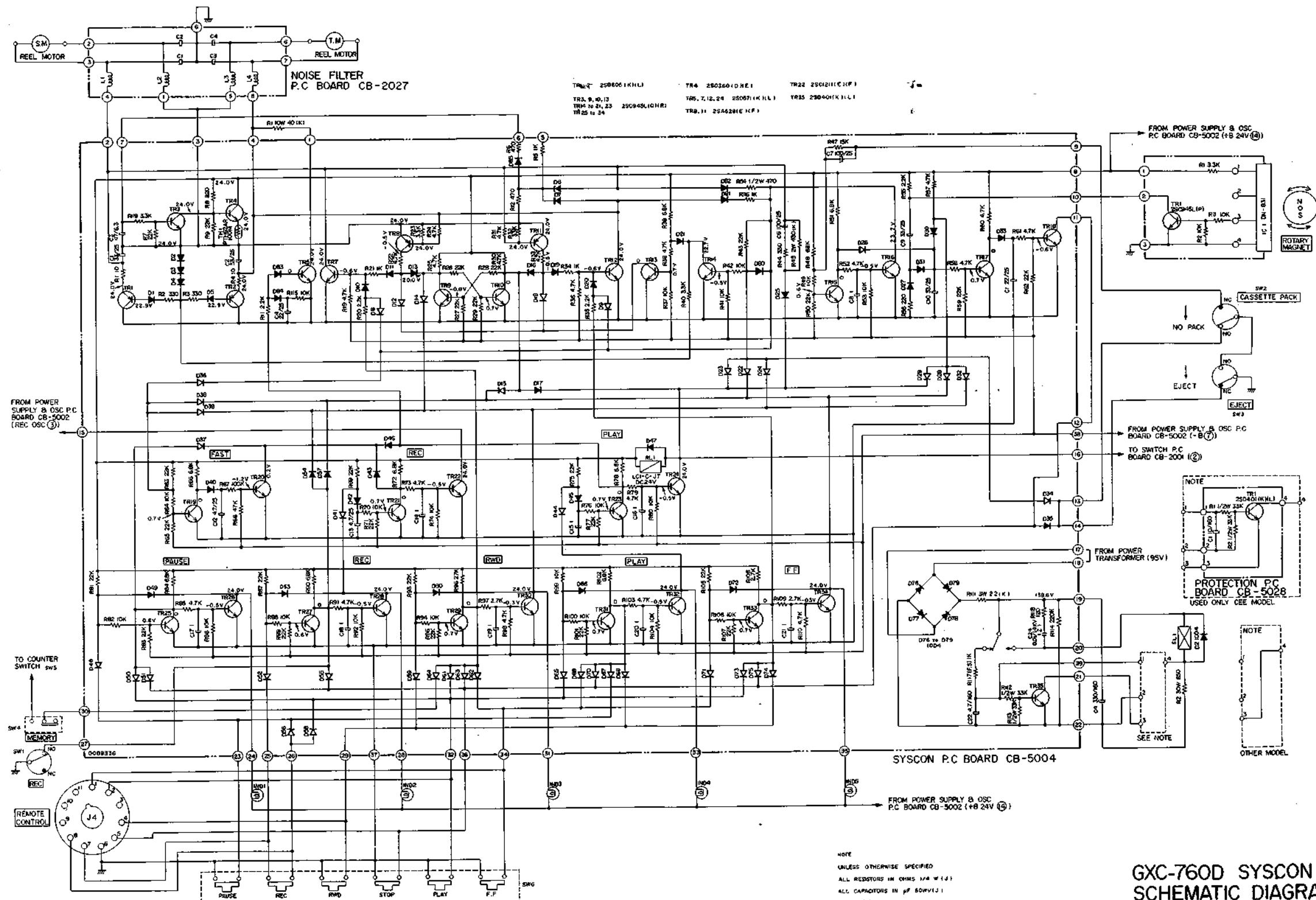

TR4 250260(DHE1) TR22 250211(C HF) TR3 9, 10, 13 TR4 7, 12, 24 250271(KHL1) TR25 250401(KLL1) TR5 16, 21, 23 250495(LCHR) TR8, 11 254528(E HF) TR25 to 24

NOTE
UNLESS OTHERWISE SPECIFIED
ALL RESISTORS IN OHMS (R W I J)
ALL CAPACITORS IN P F (80V/1 J)
ALL MARK DIODES ARE 1524735E
ALL MARK DIODES ARE 152473

GXC-760D SYSCON
SCHEMATIC DIAGRAM
NO. 5-3 1521220A

GXC-760D

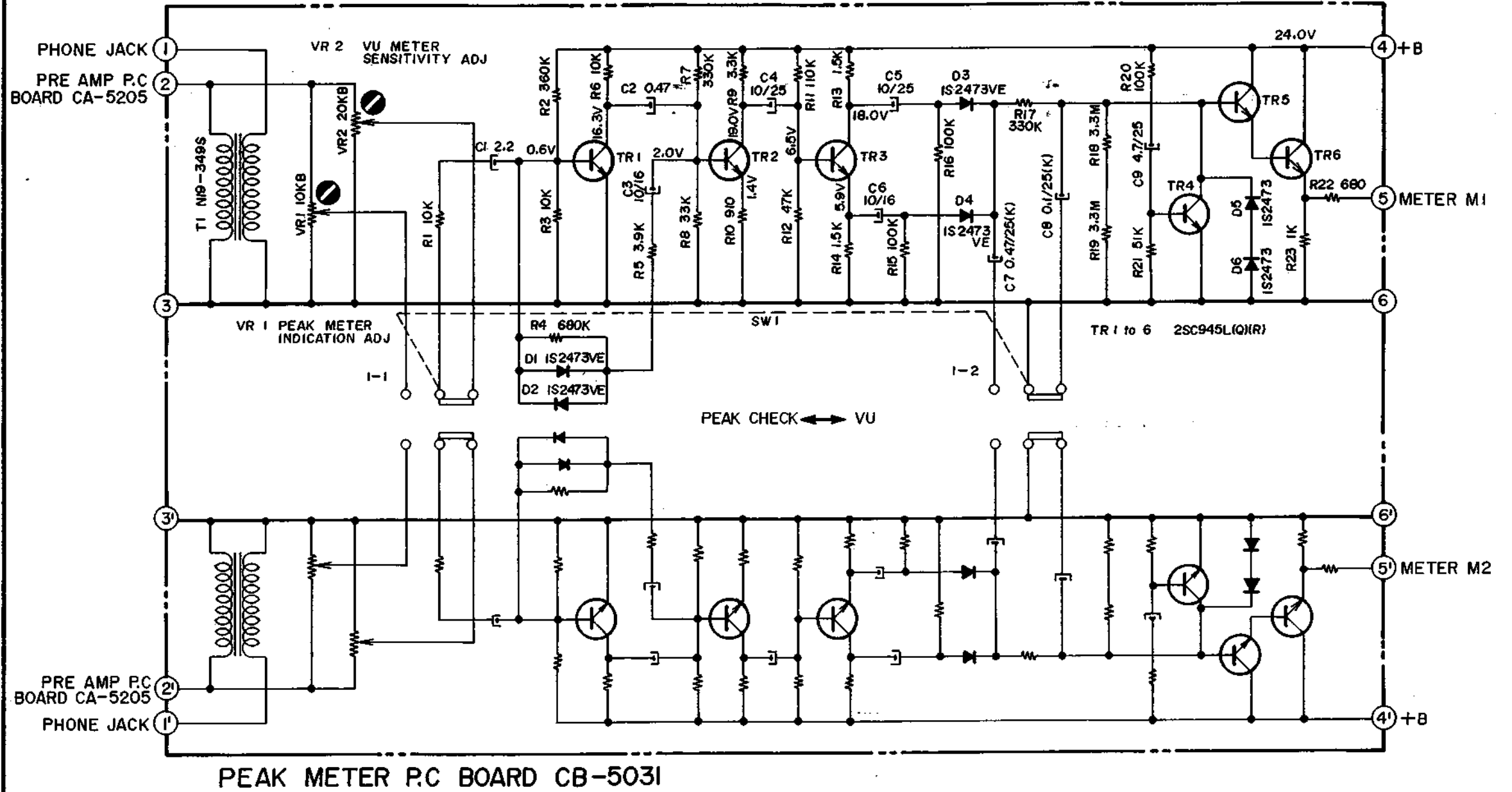

NOTE

UNLESS OTHERWISE SPECIFIED
ALL RESISTORS IN OHMS 1/4 W(J)
ALL CAPACITORS IN μ F 50WV(J) P= μ F

GXC-760D
PEAK METER
SCHEMATIC DIAGRAM
NO.5-4 1521221A
2C

0008308

GXC-760D

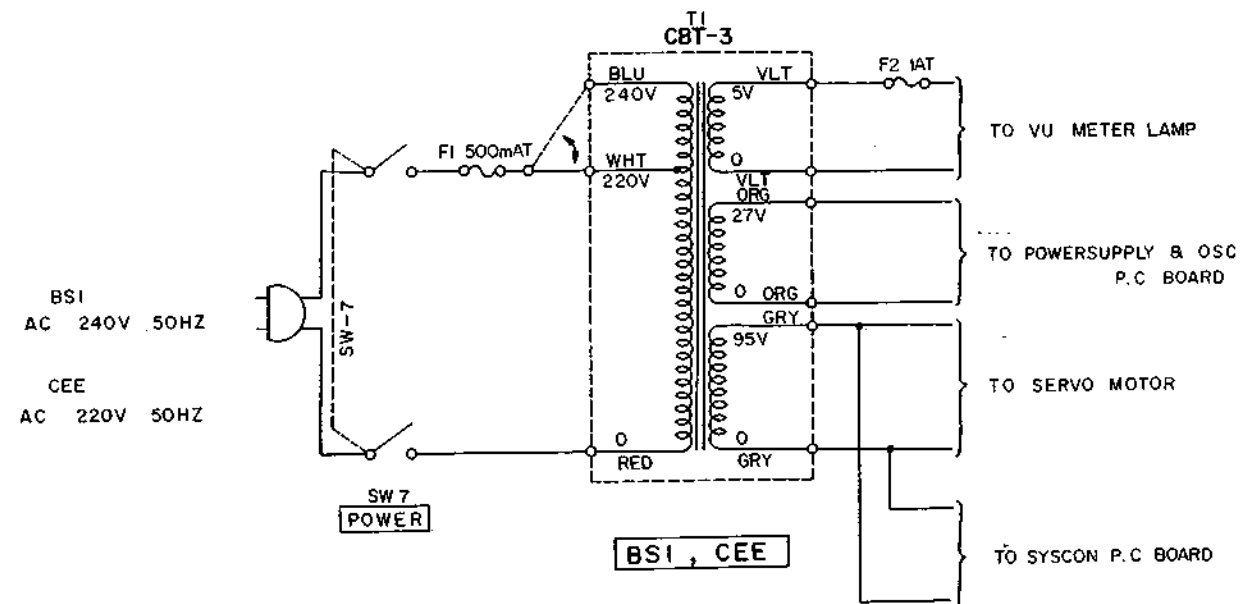
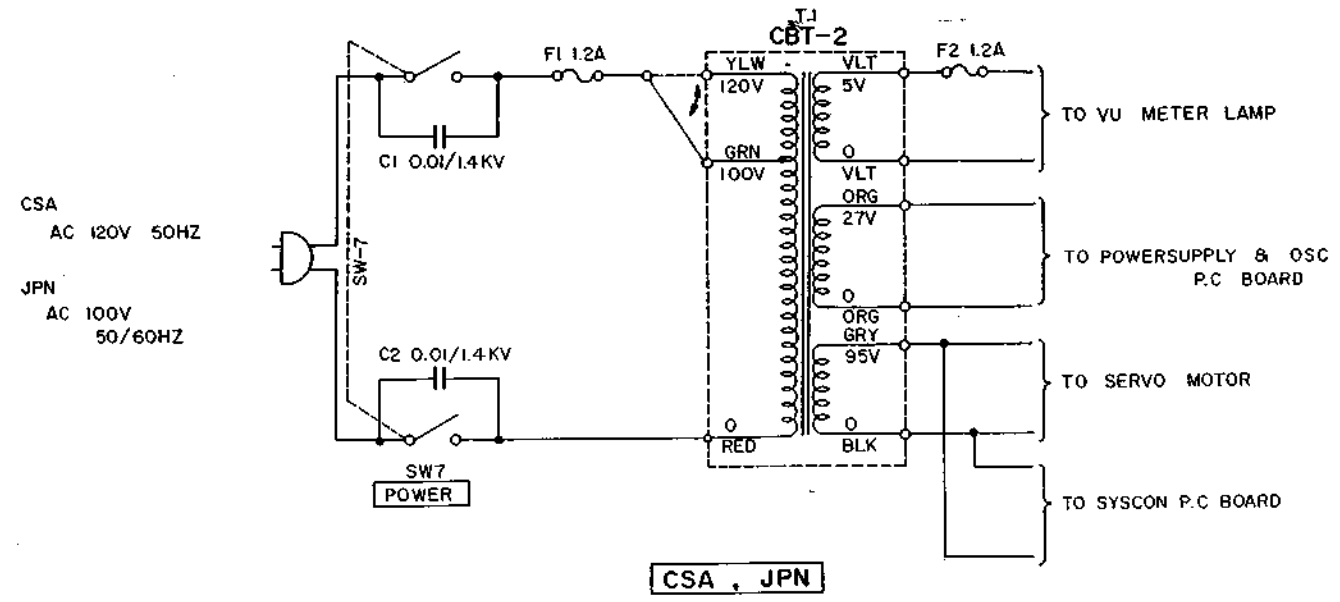

NOTE
POWER TRANSFORMER BLOCK IS DIFFERENT
ACCORDING TO AREA

GXC-760D
POWER SUPPLY
SCHEMATIC DIAGRAM
NO.5-5 1521222A

000834
000835A