

SERVICE MANUAL

PARTS LIST



AKAI STEREO TAPE RECORDER

MODEL **GXC-38**

ALSO APPLICABLE TO MODEL GXC-44D

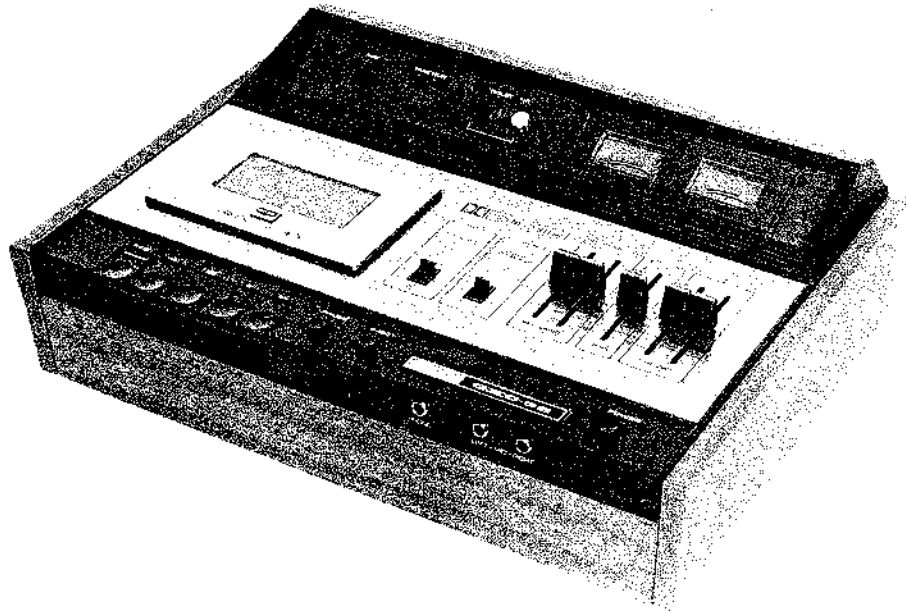

CASSETTE STEREO TAPE RECORDER

MODEL GXC-38

ALSO APPLICABLE TO MODEL GXC-44D
CASSETTE STEREO TAPE DECK

SECTION 1	SERVICE MANUAL	3
SECTION 2	PARTS LIST	25
SECTION 3	SCHEMATIC DIAGRAM	48

SECTION 1

SERVICE MANUAL

TABLE OF CONTENTS

I. SPECIFICATIONS	4
1. MODEL GXC-38	4
2. MODEL GXC-44D	5
II. MEASURING METHOD	6
1. TAPE SPEED DEVIATION	6
2. WOW AND FLUTTER	6
3. FREQUENCY RESPONSE	6
4. SIGNAL TO NOISE RATIO	6
5. TOTAL HARMONIC DISTORTION FACTOR	7
6. CROSS TALK	7
7. ERASE RATIO	7
8. POWER OUTPUT	7
III. DISMANTLING OF UNIT	8
IV. MECHANISM ADJUSTMENTS	9
1. EJECT SLIDE ADJUSTMENT	10
2. PAUSE LEVER ADJUSTMENT	10
3. ADJUSTMENT OF GAP BETWEEN TAKE-UP REEL TABLE PULLEY AND TAKE-UP WHEEL AT PAUSE MODE	10
4. F. FWD SLIDE ADJUSTMENT	10
5. RWD SLIDE ADJUSTMENT	11
6. REC. SLIDE ADJUSTMENT	11
7. MUTE SWITCH ADJUSTMENT	11
8. AUTOMATIC STOP PLUNGER SOLENOID POSITION ADJUSTMENT	12
9. F.FWD, RWD MICRO SWITCH SW10 POSITION ADJUSTMENT	12
10. LEAD SWITCH POSITION ADJUSTMENT	12
11. FLYWHEEL VERTICAL LOOSE PLAY CONFIRMATION	12
12. TAKE-UP TORQUE AT VARIOUS MODES AND TORQUE MEASURING METHOD ..	13
13. PINCH WHEEL PRESSURE MEASURING METHOD	13
V. HEAD ADJUSTMENT	14
VI. AMPLIFIER ADJUSTMENTS	15
1. PRE AMPLIFIER BLOCK DIAGRAM	15
2. PLAYBACK LEVEL ADJUSTMENT	15
3. RECORDING LEVEL ADJUSTMENT	15
4. FREQUENCY RESPONSE ADJUSTMENT	16
5. RECORDING BIAS FREQUENCY MEASUREMENT	16
6. RECORDING BIAS VOLTAGE AND ERASE VOLTAGE MEASUREMENT	16
7. DOLBY AMPLIFIER ADJUSTMENT	16
8. POWER AMPLIFIER VOLTAGE ADJUSTMENT	18
VII. MOTOR AND COIL WINDING D.C. RESISTANCE	19
VIII. COMPOSITE VIEWS OF COMPONENTS	20

I. SPECIFICATIONS

1. MODEL GXC-38

An asterisk next to a figure indicates the minimum guaranteed performance.

TRACK SYSTEM	4-track 2-channel stereo system	
TAPE SPEED	1-7/8 ips (4.75 cm/sec) $\pm 3\%$	
WOW AND FLUTTER	Less than 0.12% (*0.27%) W.R.M.S.	
FREQUENCY RESPONSE	Chrome Tape	30 to 18,000 Hz (*50 to 14,000 Hz ± 4 dB)
	Low Noise Tape	30 to 16,000 Hz (*50 to 13,000 Hz ± 4 dB)
SIGNAL TO NOISE RATIO	Better than 50 dB (*45 dB) without dolby process	
HUM AND NOISE	Less than 10 mV for UL and JPN models Less than 5 mV for other models	
DISTORTION	Less than 1.5% (*3%) at 1,000 Hz "0" VU recording	
CROSS TALK	Better than 25 dB at 3 VU recording	
ERASE RATIO	Better than 70 dB at 3 VU recording	
BIAS FREQUENCY	60 to 65 ± 3 kHz	
BIAS LEAK	Less than -50 VU with recording level control at 6 position	
OUTPUTS	Line Output	0 (0.775V) ± 1.5 dB, using a 333 Hz "0" VU recorded tape
	Din Output	-3 (0.55V) ± 1.5 dB, using a 333 Hz "0" VU recorded tape
	Phone Output	30 mV at 8 Ω
	Speaker Output	6W each channel at 8 Ω *2W each channel at 8 Ω for UL models *4W each channel at 8 Ω for other models
INPUTS	Mic Input	More than 0.5 mV Impedance: 4.7 k Ω
	Line Input	More than 80 mV Impedance: 200 k Ω
	Din Input	More than 5 mV (low) 80 mV (high)
RECORDING CAPACITY	1 hour stereo recording, using a C-60 cassette tape	
F.FWD AND RWD TIME	55 sec., using a C-60 cassette tape	
HEADS	Recording/Playback Head	4-track 2-channel GX Recording/Playback Head Type: P4-340 Gap: 1.4 to 1.9 microns Impedance: 1,200 Ω $\pm 20\%$ at 1 kHz D.C. Resistance: 180 Ω (approx)
	Erase Head	2-track 1-channel Erase Head Type: ME-136A Gap: 0.3 $\begin{smallmatrix} +0.1 \\ -0 \end{smallmatrix}$ mm Impedance: 330 Ω $\pm 10\%$ at 50 kHz D.C. Resistance: 8 Ω $\pm 30\%$
MOTOR	4-pole induction inner-rotor motor Type: IB-440 Revolution: 1,390 ± 25 r.p.m./1,680 ± 30 r.p.m. at 50/60 Hz	
TRANSISTORS AND FET	2SC711(F) (G) ... 11 2SC1096(K) (L) ... 2 Dolby Circuit 2SA564(Q) ... 2 2SC458(C) ... 6 Power Amp. Circuit 2SA636(K) (L) ... 2 2SC1312(F) (G) ... 2	2SC945(P) (Q) (R) ... 2 2SC1312(G) (H) ... 6 2SC458LG(C) (D) ... 6 2SK30(GR) ... 2 2SC971(2) (3) red ... 2 2SC1098(K) (L) ... 2
THERMISTERS	42D26 ... 2	
VARISTORS	RV ... 4	
DIODES	WG599 ... 3 1N34A ... 2 10D05 ... 1 Dolby Circuit WG599 ... 6 WZ085 ... 2	WG713 ... 1 1N4001 ... 4 WZ192 ... 1 1N34A ... 4
POWER SUPPLY	100 to 240V A.C. 50/60 Hz for universal and WG models 120V A.C. 60 Hz for UL models	
POWER CONSUMPTION	30W	
DIMENSIONS	410(W) \times 123(H) \times 295(D) mm (16.1" \times 4.8" \times 11.6")	
WEIGHT	7 kg (15.4 lbs.)	

NOTE: Specifications subject to change without notice.

2. MODEL GXC-44D

An asterisk next to a figure indicates the minimum guaranteed performance.

TRACK SYSTEM	4-track 2-channel stereo system	
TAPE SPEED	1-7/8 ips (4.75 cm/sec) $\pm 3\%$	
WOW AND FLUTTER	Less than 0.12% (*0.27%) W.R.M.S.	
FREQUENCY RESPONSE	Chrome Tape	30 to 18,000 Hz (*50 to 14,000 Hz ± 4 dB)
	Low Noise Tape	30 to 16,000 Hz (*50 to 13,000 Hz ± 4 dB)
SIGNAL TO NOISE RATIO	Better than 50 dB (*45 dB) without dolby process	
DISTORTION	Less than 1.5% (*3%) at 1,000 Hz "0" VU recording	
CROSS TALK	Better than 25 dB at 1,000 Hz "0" VU recording	
ERASE RATIO	Better than 70 dB at 1,000 Hz "0" VU recording	
BIAS FREQUENCY	60 to 65 ± 3 kHz	
BIAS LEAK	Less than -50 VU with recording level control at 6 position	
OUTPUTS	Line Output	0 (0.775V) ± 1.5 dB, using a 333 Hz "0" VU recorded tape
	Din Output	-3 (0.55V) ± 1.5 dB, using a 333 Hz "0" VU recorded tape
	Phone Output	30 mV at 8 Ω
INPUTS	Mic Input	More than 0.5 mV Impedance: 4.7 k Ω
	Line Input	More than 80 mV Impedance: 200 k Ω
	Din Input	More than 50 mV (low) 80 mV (high)
RECORDING CAPACITY	1 hour stereo recording, using a C-60 cassette tape	
F.FWD AND RWD TIME	55 sec., using a C-60 cassette tape	
HEADS	Recording/Playback Head	4-track 2-channel GX Recording/Playback Head Type: P4-340 Gap: 1.4 to 1.9 microns Impedance: 1,200 Ω $\pm 20\%$ at 1 kHz D.C. Resistance: 180 Ω (approx)
	Erase Head	2-track 1-channel Erase Head Type: ME-136A Gap: 0.3 $^{+0.1}_{-0}$ mm Impedance: 330 Ω $\pm 10\%$ at 50 kHz D.C. Resistance: 8 Ω $\pm 30\%$
MOTOR	4-pole induction inner-rotor motor Type: IB-440 Revolutions: 1,390 ± 25 r.p.m./1,680 ± 30 r.p.m. at 50/60 Hz	
TRANSISTORS AND FET	2SA733(P) (Q) (R) ... 1 2SC711(F) (G) ... 11 2SC1096(K) (L) ... 2 Dolby Circuit 2SA564(Q) ... 2 2SC458C ... 6	2SC945(P) (Q) (R) ... 2 2SC1312(G) (H) ... 6 2SC458LG(C) (D) ... 6 2SK30(GR) ... 2
DIODES	WG599 ... 4 1N34A ... 2 10D05 ... 1 Dolby Circuit WG599 ... 6 WZ085 ... 2	WZ192 ... 1 1N4001 ... 1 1N34A ... 4
POWER SUPPLY	100V A.C. 50/60 Hz for JPN models	
POWER CONSUMPTION	20W	
DIMENSIONS	410(W) \times 132(H) \times 295(D) mm (16.1" \times 5.2" \times 11.6")	
WEIGHT	6.6 kg (14.5 lbs.)	

NOTE: Specifications subject to change without notice.

II. MEASURING METHOD

1. TAPE SPEED DEVIATION

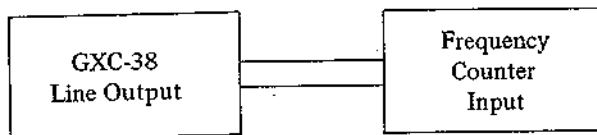

Fig. 1

As shown in Fig. 1, connect a Frequency Counter to the Line Output. Take a Frequency Counter reading at the beginning, middle, and end of tape winding during playback. The maximum value of these respective readings will represent tape speed deviation.

2. WOW AND FLUTTER

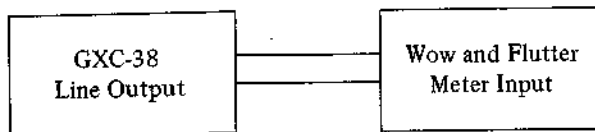

Fig. 2

Method A

As shown in Fig. 2, connect the Line Output to the Input of a Wow and Flutter Meter. Use a 3,000 Hz pre-recorded test tape and take a Wow and Flutter Meter reading at the beginning, middle, and end of tape winding. The maximum value of these respective readings will represent the Wow and Flutter.

Method B

Supply a 3,000 Hz sine wave signal from an Audio Frequency Oscillator and make a recording on a blank tape at the beginning, middle, and end of tape winding. Rewind and play tape. Measure Wow and Flutter Meter. (The Wow and Flutter value of Method B will be close to twice that of Method A.)

3. FREQUENCY RESPONSE

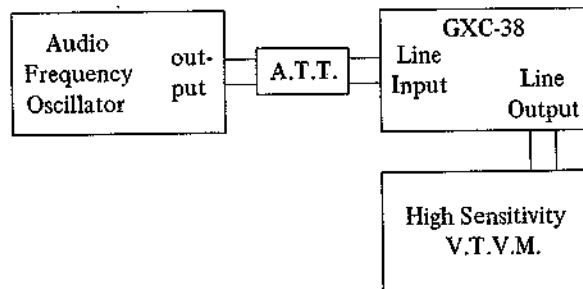

Fig. 3

For measuring Frequency Response, connect instruments as shown in Fig. 3 and proceed as follows:

- 1) Supply a 1,000 Hz sine wave to the Line Input from an Audio Frequency Oscillator through an Attenuator. Set recorder to recording mode and turn recording level control volume and volume control to maximum. Adjust Attenuator to obtain a 0 dB V.T.V.M. reading.
- 2) Under conditions described in 1) above, re-adjust Attenuator so that the Line Output is -20 dB, and record 50 to 13,000 Hz spot frequencies.
- 3) Rewind the tape and playback from the beginning. Take V.T.V.M. spot frequency readings and plot values on a graph.

NOTE: When measuring Frequency Response, new tape should be used.

4. SIGNAL TO NOISE RATIO

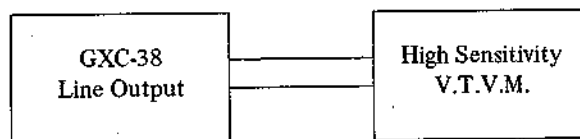

Fig. 4

As shown in Fig. 4, connect a High Sensitivity V.T.V.M. to the Line Output. Playback a 333 Hz "0" VU pre-recorded test tape and measure the output. Then remove the tape and measure the noise level under the same condition. Convert each of the measured values into decibels.

5. TOTAL HARMONIC DISTORTION FACTOR

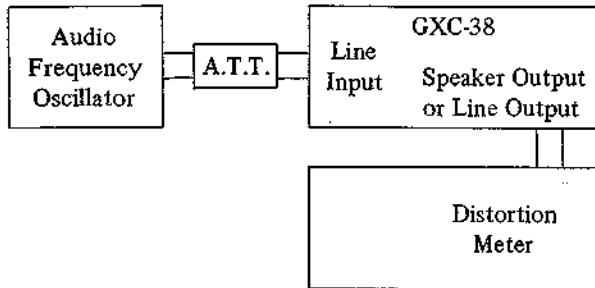

Fig. 5

Connect the measuring instruments as shown in Fig. 5 and record a 1,000 Hz sine wave signal at "0" VU. Playback the resultant signal and measure the overall distortion factor. Measure the noise level of the tape recorder without the tape. Connect the Audio Frequency Oscillator directly to the distortion meter for measurement of the distortion factor of the oscillator. The required distortion factor can be obtained from the results of the above measurement by the following formula:

$$d_0 = d - d_1 - d_2$$

where, d_0 = Required distortion factor
 d = Overall distortion factor
 d_1 = Noise level
 d_2 = Distortion factor of the oscillator

NOTE: When measuring the distortion factor, new tape should be used.

6. CROSS TALK (Cross talk between the tracks)

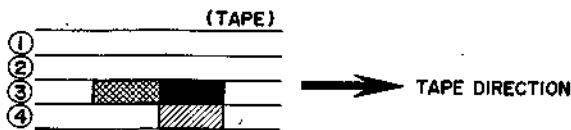

Fig. 6

As shown in Fig. 6, first record a 1,000 Hz sine wave signal on Track No. 3 at +3 VU level. Next, record under a non-input condition. Then, playback the tape on Tracks No. 3 and 4 through the B.P.F. (band pass filter sensitivity . . . 1:1) and obtain a ratio between the two from the following formula:

$$C = 20 \log \frac{E_0}{E_2 - E_1} \text{ (dB)}$$

where, C = Desired cross talk ratio (dB)

E_0 = 1,000 Hz signal output level

E_2 = 1,000 Hz cross talk level

E_1 = Non-input signal recorded level



7. ERASE RATIO

As shown in Fig. 4, connect a High Sensitivity V.T.V.M. to the Line Output. Playback a virgin tape and take a V.T.V.M. reading of the output level. Next, record a 1,000 Hz sine wave signal at +3 VU, then playback this recorded signal and take a V.T.V.M. reading of the output level. Next, using this pre-recorded tape, record under a non-input condition and take a reading of the noise level output of the erased signal and obtain a ratio between the two from the following formula:

$$E_r = 20 \log \frac{E_0}{E_2 - E_1} \text{ (dB)}$$

where, E_r = Desired erase ratio (dB)

E_0 = 1,000 Hz signal output level

E_2 = Non-input signal recorded level

E_1 = Virgin tape noise output level

8. POWER OUTPUT

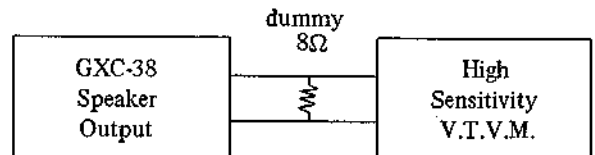

Fig. 7

As shown in Fig. 7, connect an 8Ω dummy load resistor to the Speaker Output and connect this terminal to a High Sensitivity V.T.V.M. Playback a 1,000 Hz "0" VU pre-recorded test tape and take a V.T.V.M. reading of the output level. The resultant output can be obtained from the results of the above measurement by using the following formula:

$$P = \frac{E^2}{R} \text{ (W)}$$

where, P = Desired power output (watts)

E = Measured voltage (R.M.S.)

$R = 8\Omega$

III. DISMANTLING OF UNIT

In case of trouble, etc. necessitating disassembly, please disassemble in the order shown in photographs. Reassemble in reverse order.

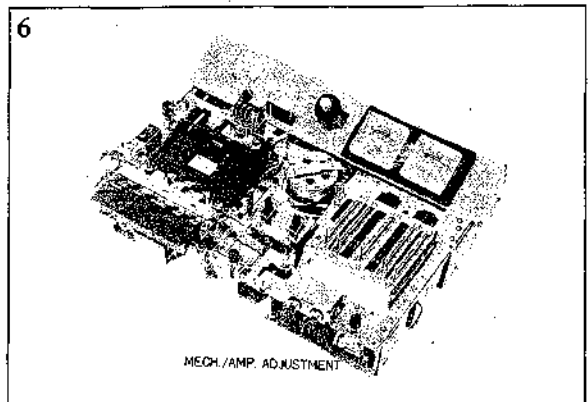
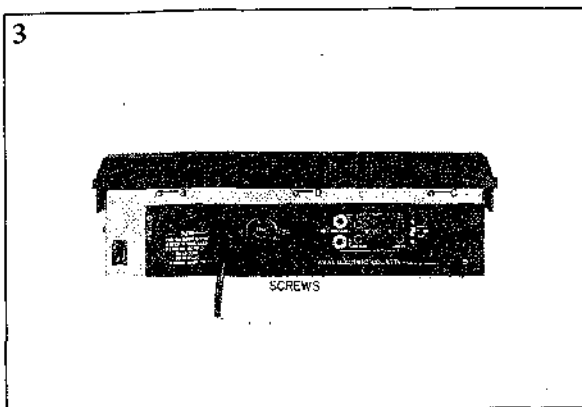
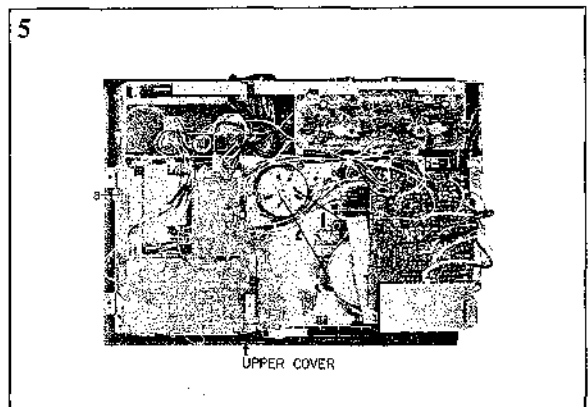
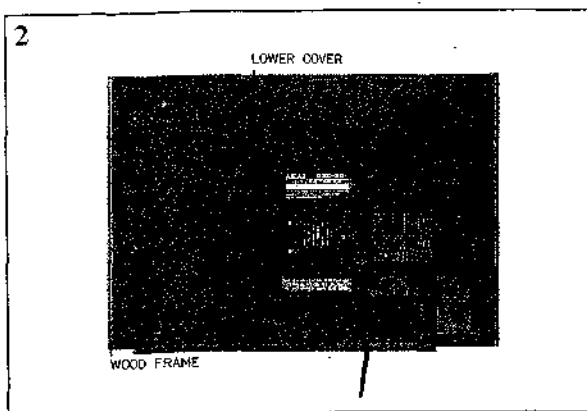
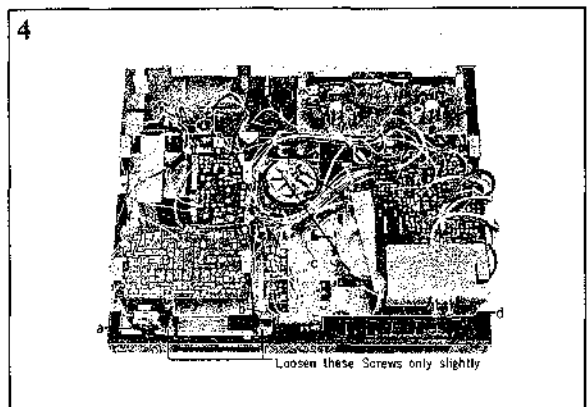
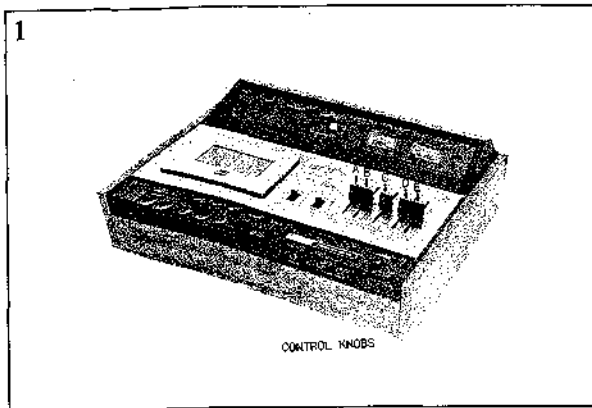

IV. MECHANISM ADJUSTMENTS

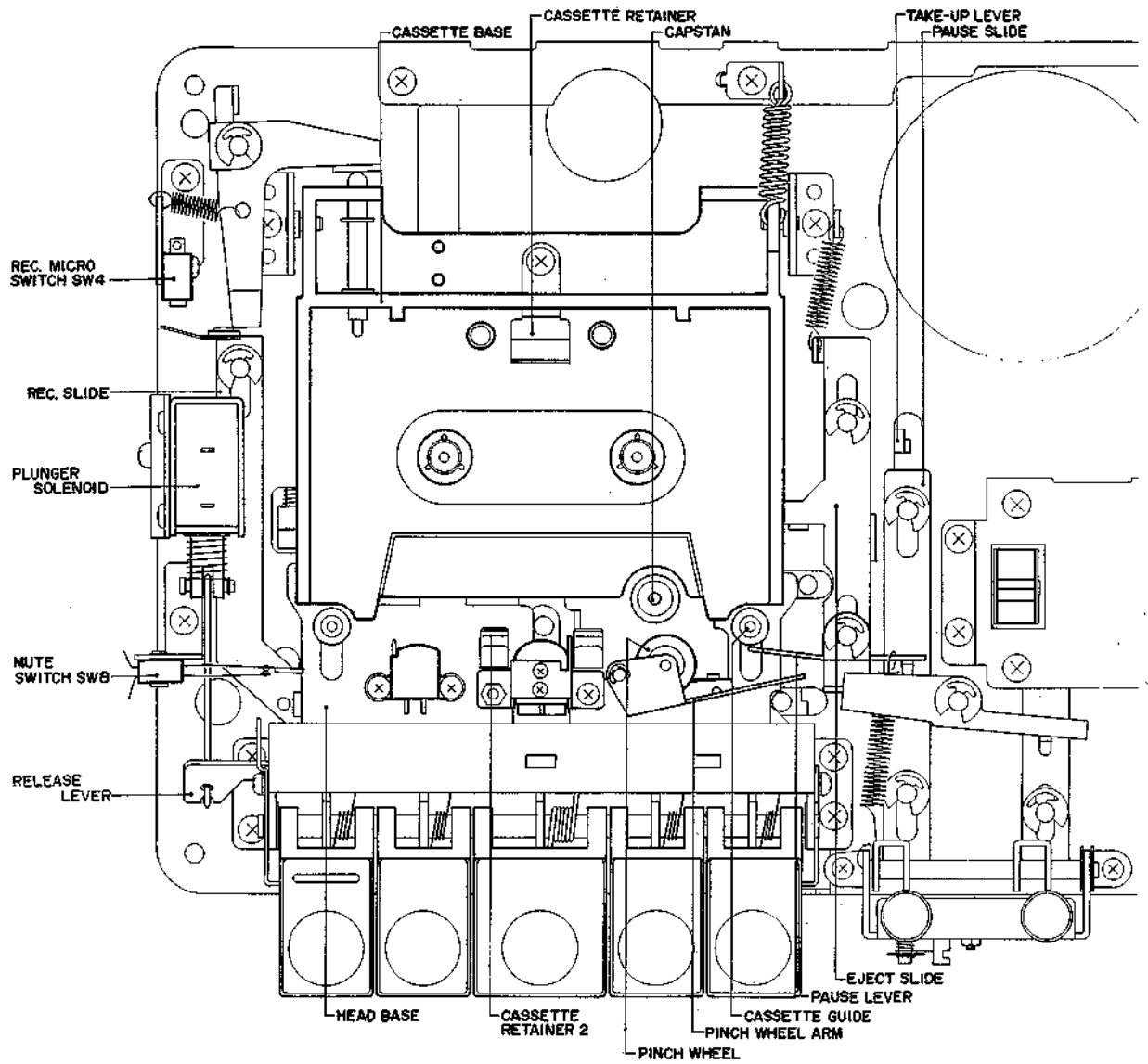

Fig. 8

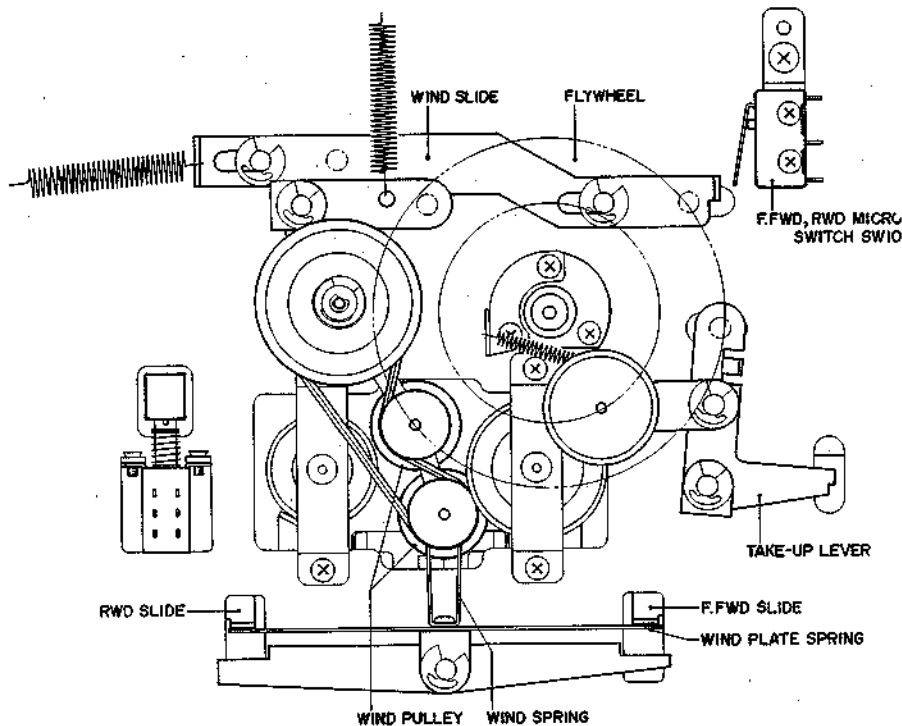

Fig. 9

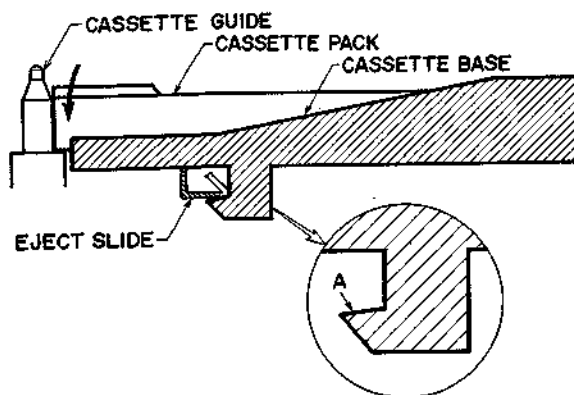

Fig. 10

1. EJECT SLIDE ADJUSTMENT (See Fig. 10)

Confirm that the cassette pack slides the cassette guide and when it completely reaches the bottom, the cassette base is locked by the Eject Slide. If cassette base is not locked, file off uneven edges of Side (A) of cassette base.

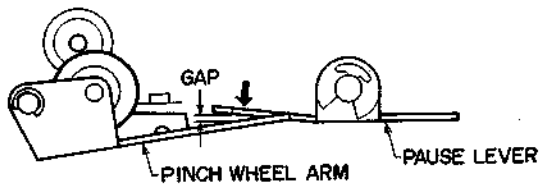

Fig. 11

2. PAUSE LEVER ADJUSTMENT (See Fig. 11)

Bend the part of pause lever indicated by arrow in Fig. 11 so that at playback mode the gap between the pinch wheel arm and pause lever is more than 0.5 mm.

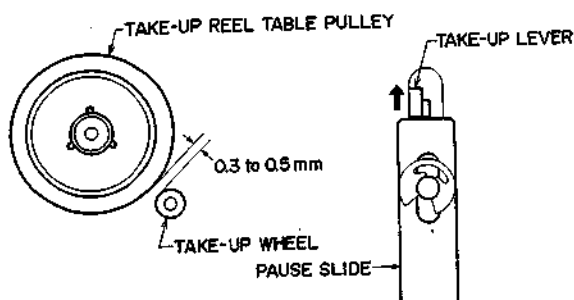

Fig. 12

3. ADJUSTMENT OF GAP BETWEEN TAKE-UP REEL TABLE PULLEY AND TAKE-UP WHEEL AT PAUSE MODE (See Fig. 12)

Bend the take-up lever in the direction of the arrow in Fig. 12 so that when the machine is set to pause from playback mode, the take-up wheel completely separates from take-up reel table pulley and the gap width is from 0.3 to 0.5 mm.

4. F.F.WD SLIDE ADJUSTMENT (See Fig. 13)

Adjust by bending the F.F.WD Slide so that when the F.F.WD and STOP buttons are gently braked simultaneously, the wind pulley separates from the take-up reel table and this gap width is 0.5 mm.

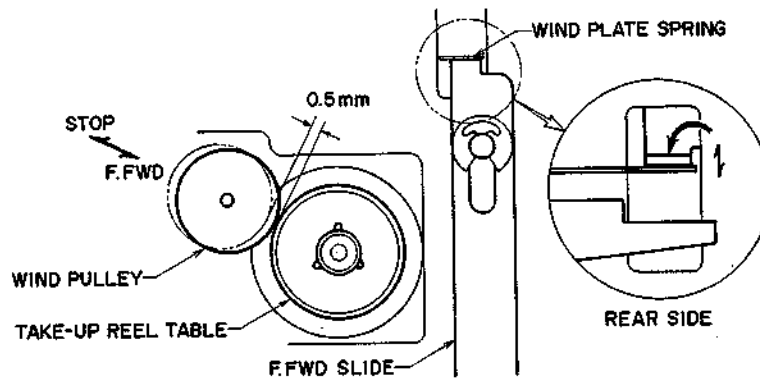

Fig. 13

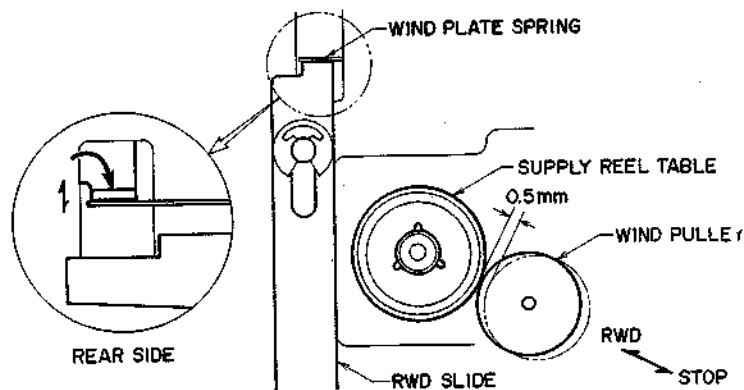

Fig. 14

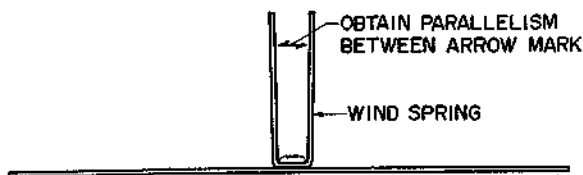

Fig. 15

5. RWD SLIDE ADJUSTMENT (See Fig. 14)

Adjust by bending the Rewind Slide so that when the RWD and STOP Buttons are gently braked simultaneously, the wind pulley separates from the Supply Reel table and this gap width is 0.5 mm.

NOTE: In the event that by bending the F.Fwd and Rwd Slides a 0.5 mm gap on both cannot be attained, check the wind spring for parallelism. If it is not parallel, remove and bend wind spring by hand to obtain parallelism. (See Fig. 15)

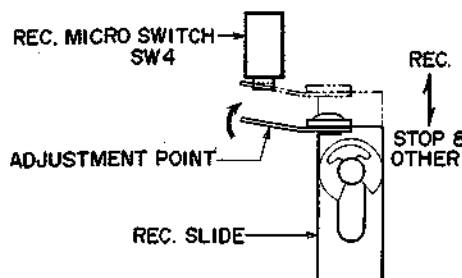

Fig. 16

6. REC. SLIDE ADJUSTMENT (See Fig. 16)

At Stop mode, bend adjustment point (phosphor bronze plate) of Rec. Slide toward arrow. (Fig. 16) When the Rec. Button is depressed, the phosphor bronze plate must properly turn ON the Rec. micro switch.

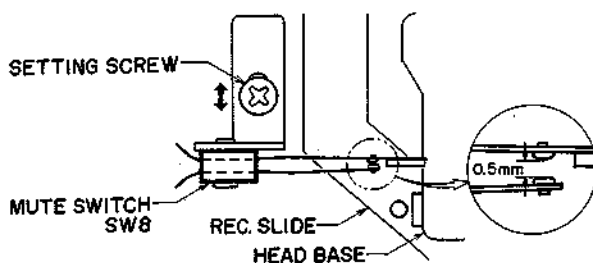

Fig. 17

7. MUTE SWITCH ADJUSTMENT (See Fig. 17)

Loosen setting screw, and move Mute Switch back and forth and set so that at Rec. mode, the Rec. Slide turns OFF the Mute Switch, and the sub plate leaf gap is 0.5 mm.

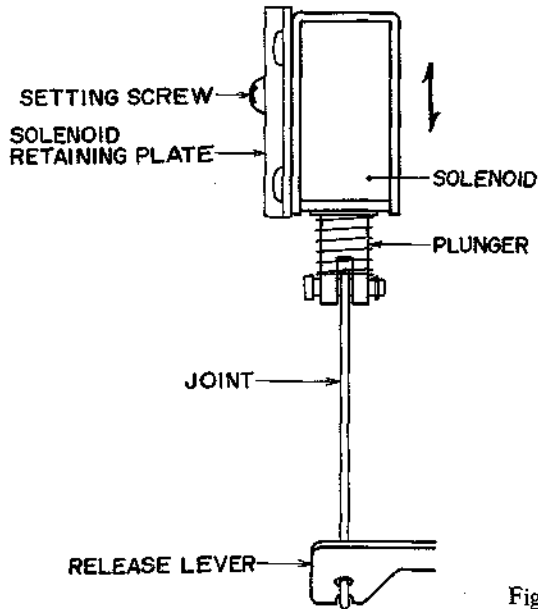

Fig. 18

8. AUTOMATIC STOP PLUNGER SOLENOID POSITION ADJUSTMENT (See Fig. 18)

- 1) Loosen the setting screw which fixes the solenoid so that the solenoid can be moved as indicated by the \updownarrow mark in Fig. 18.
- 2) Set machine to F.FWD mode and when the plunger has fully entered the center of the solenoid, fix setting screw at place at which the solenoid is moved to the rear, the release lever is drawn, and F.FWD is braked.

Reference: After Automatic Stop Plunger Solenoid Position Adjustment has been completed, supply a 10% lower voltage than specified power source and confirm that automatic stop functions perfectly from F.Fwd as well as from recording and playback modes.

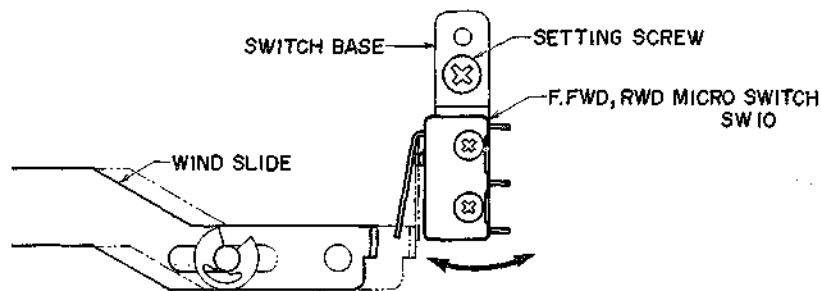

Fig. 19

9. F.FWD, RWD MICRO SWITCH SW10 POSITION ADJUSTMENT (See Fig. 19)

Loosen setting screw and move switch base in direction of arrow in Fig. 19 until when F.FWD or RWD mode is effected, the wind slide turns ON F.FWD, RWD Micro Switch perfectly and fix setting screw to maintain optimum condition.

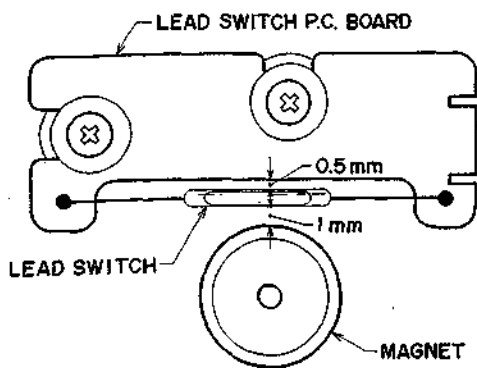

Fig. 20

10. LEAD SWITCH POSITION ADJUSTMENT (See Fig. 20)

Adjust Lead Switch Position to obtain conditions shown in Fig. 20.

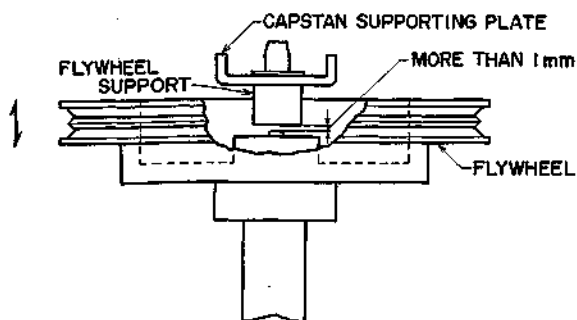

Fig. 21

11. FLYWHEEL VERTICAL LOOSE PLAY CONFIRMATION (See Fig. 21)

Confirm that as shown in the diagram in Fig. 21, the gap between the flywheel and capstan supporting plate is within 0.2 to 1 mm.

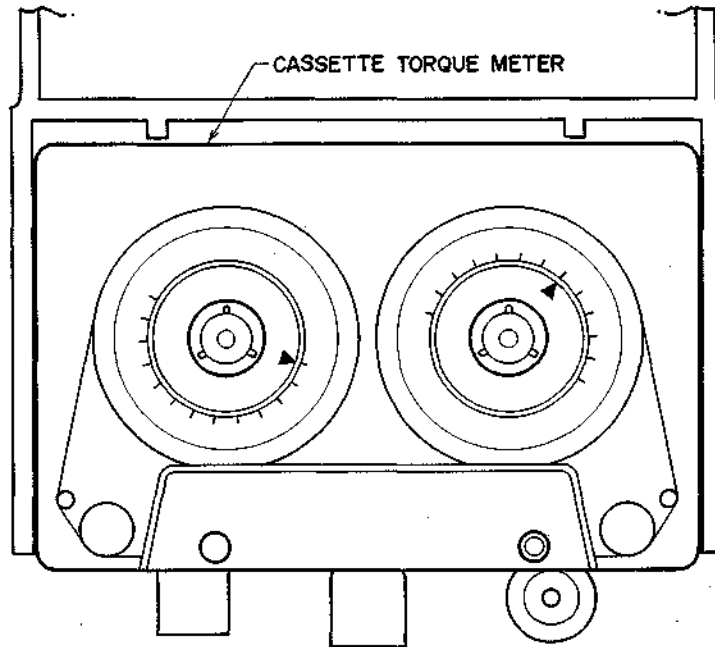

Fig. 22

12. TAKE-UP TORQUE AT VARIOUS MODES AND TORQUE MEASURING METHOD (See Fig. 22)

As shown in Fig. 22, set a cassette torque meter on cassette base, and take a reading of the \blacktriangle indication at each respective mode.

PLAYBACK MODE	$50 \pm 10\text{g}\cdot\text{cm}$
F.FWD MODE	$80\text{g}\cdot\text{cm}$
RWD MODE	$80\text{g}\cdot\text{cm}$

NOTE: Take the torque meter indication value $+10\text{g}\cdot\text{cm}$ as recorder take-up torque.

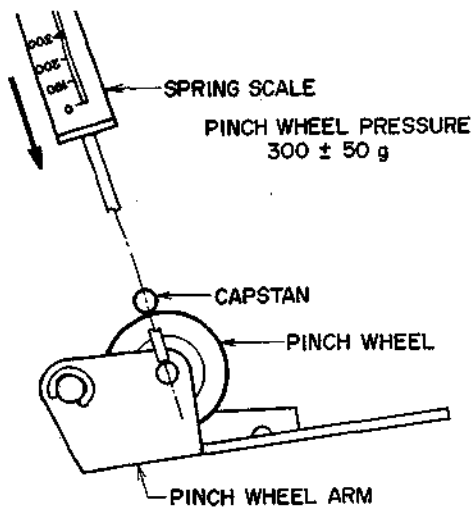

Fig. 23

13. PINCH WHEEL PRESSURE MEASURING METHOD (See Fig. 23)

As shown in Fig. 23, at playback mode, press the pinch wheel arm toward shaft with a spring scale, and when the pinch wheel separates from the capstan, read the spring scale indication.

V. HEAD ADJUSTMENT

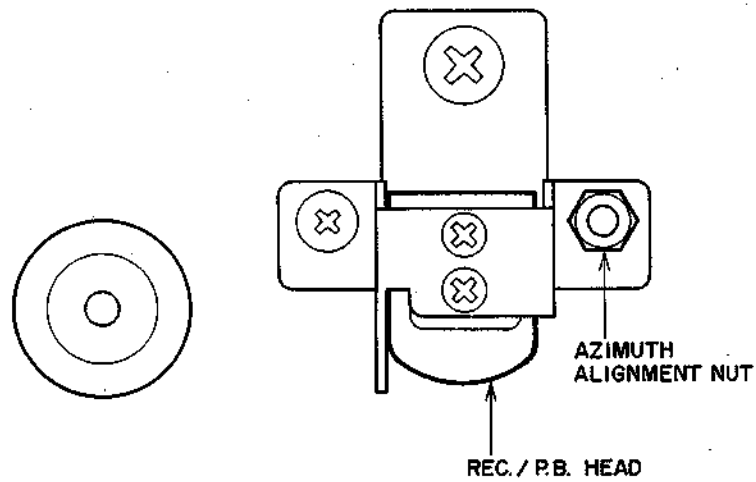

Fig. 24

RECORDING/PLAYBACK HEAD AZIMUTH ALIGNMENT ADJUSTMENT (See Fig. 24)

- 1) Connect a High Sensitivity V.T.V.M. to the line outputs.
- 2) Playback a 10 kHz pre-recorded test tape.
- 3) Turn Azimuth Alignment Nut to left and right and adjust to obtain maximum left/right channel V.T.V.M. indication.
- 4) Always demagnetize heads following head adjustments.

VI. AMPLIFIER ADJUSTMENTS

1. PRE AMPLIFIER BLOCK DIAGRAM

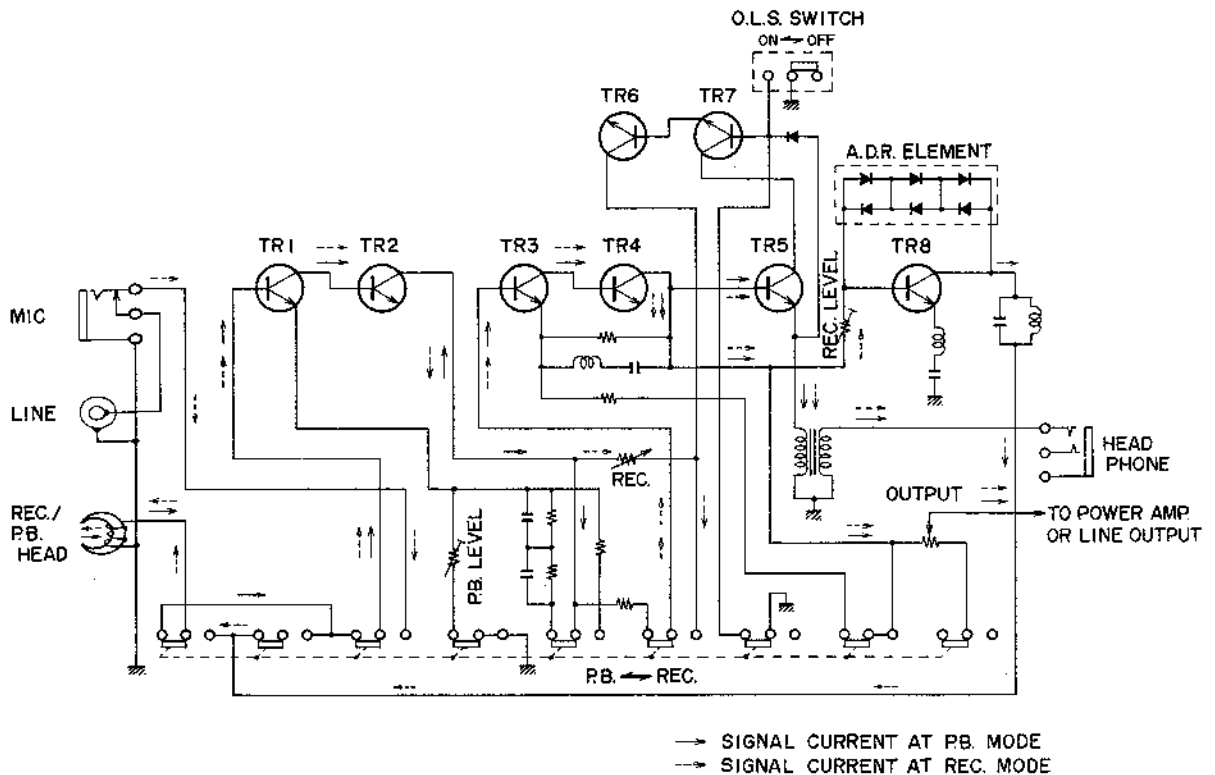

Fig. 25

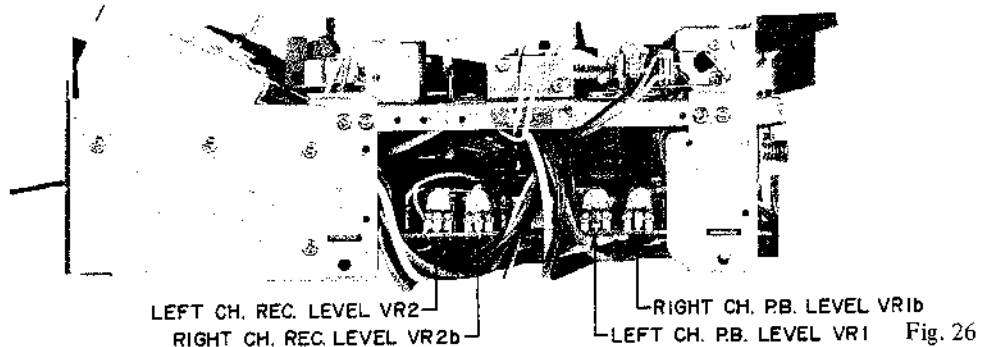

Fig. 26

2. PLAYBACK LEVEL ADJUSTMENT

(See Fig. 26)

- 1) Connect a High Sensitivity V.T.V.M. to the line outputs.
- 2) Turn Output Level Controls to maximum. (Deck type only)
- 3) Playback a 333 Hz pre-recorded cassette test tape and adjust Semi-fixed Resistors VR1 1 k Ω (left ch.), VR1b 1 k Ω (right ch.) of Pre-amp. P.C. Board to obtain a V.T.V.M. indication of 0 dB (0.775V).

3. RECORDING LEVEL ADJUSTMENT

(See Fig. 26)

- 1) Set Tape Selector to LOW NOISE and load a Low Noise blank cassette tape.
- 2) Set Recording Level Controls and Output Level Controls to maximum. (If recorder type, Recording Level Controls only)
- 3) Set recorder to recording mode, and supply a 1,000 Hz signal to the line inputs from an Audio Frequency Oscillator through an Attenuator.
- 4) Adjust Attenuator to obtain a V.T.V.M. indication of 0 dB (0.775V).

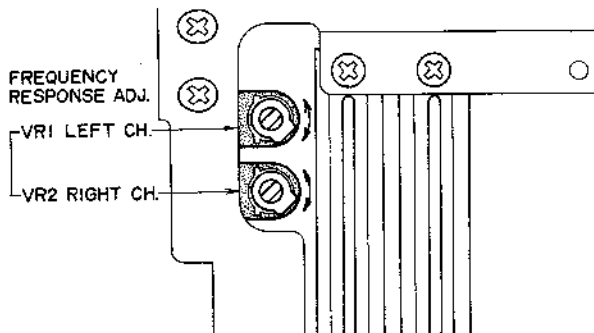

Fig. 27

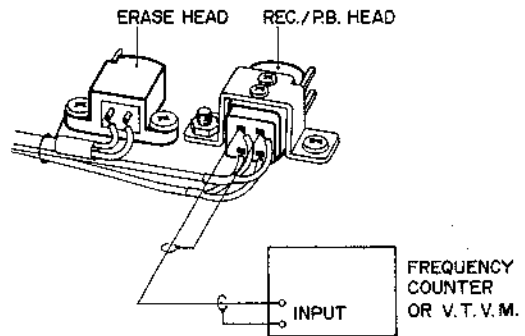

Fig. 28

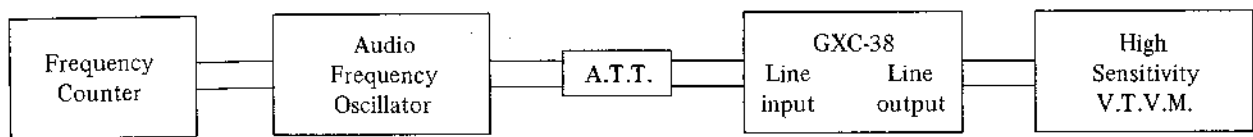

Fig. 29

- 5) Under these conditions, record for a few seconds and then playback this recorded tape and check the V.T.V.M. indications.
- 6) In case the line output level is not 0 dB, adjust Semi-fixed Resistors VR2 20 k Ω (left ch.) and VR2b 20 k Ω (right ch.) of Pre-amp. P.C. Board to obtain a 0 dB line output level and repeat Item 5 above.

4. FREQUENCY RESPONSE ADJUSTMENT (See Fig. 27)

- 1) Playback the 1,000 Hz and 10,000 Hz signals recorded in Frequency Response measuring method procedure and adjust Semi-fixed Resistors VR1 300 k Ω (left ch.) and VR2 300 k Ω (right ch.) of OSC. P.C. Board to obtain a flat output level at these 2 frequencies.
- 2) Re-check recording level following Frequency Response Adjustment.

NOTE: Electric shock will cause the GX Head to become magnetized, increasing distortion. Consequently, it is important that the heads be demagnetized with a large type demagnetizer after all adjustments have been completed.

5. RECORDING BIAS FREQUENCY MEASUREMENT (See Fig. 28)

Set recorder to Rec. mode. Connect a frequency counter between the coil terminals of the Rec./P.B. Head as shown in Fig. 28 and read indication.

6. RECORDING BIAS VOLTAGE AND ERASE VOLTAGE MEASUREMENT

Set recorder to Rec. mode. As shown in Fig. 28 connect a V.T.V.M. between the coil terminals of each head and read indication.

ERASE VOLTAGE Abt 36V A.C. (Low Noise)
 Abt 49V A.C. (Chrome)

RECORDING
BIAS VOLTAGE 4 to 26V A.C.

7. DOLBY AMPLIFIER ADJUSTMENT

- 1) 19 kHz Filter Adjustment
 - a) Connect the various measuring instruments as shown in Fig. 29.
 - b) Using the Frequency Counter, set the oscillation frequency of the Audio Frequency Oscillator to exactly 19 kHz and supply this signal to the line input.
 - c) Set Recording Level Control Volume VR1 50 k Ω (left ch.) VR2 50 k Ω (right ch.) and Volume Control VR3 10 k Ω (left ch.) VR4 10 k Ω (right ch.) to "10" position.

NOTE: In the case of Recorder type volume controls can be at any position.

- d) Set recorder to recording mode, and adjust the dust core of 19 kHz Filter Coil L2 (left ch.) L2b (right ch.) of the Dolby Amp. P.C. Board to obtain minimum line output level.

2) Recording Circuit Adjustment

- a) Connect the various measuring instruments as shown in Fig. 29.

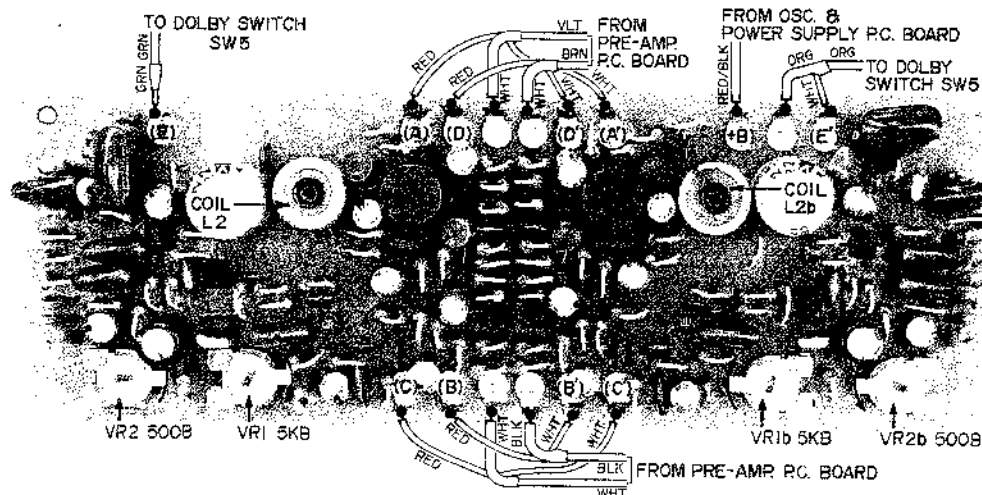

Fig. 30 DOLBY AMP. P.C. BOARD CG-5202 (Face Side)

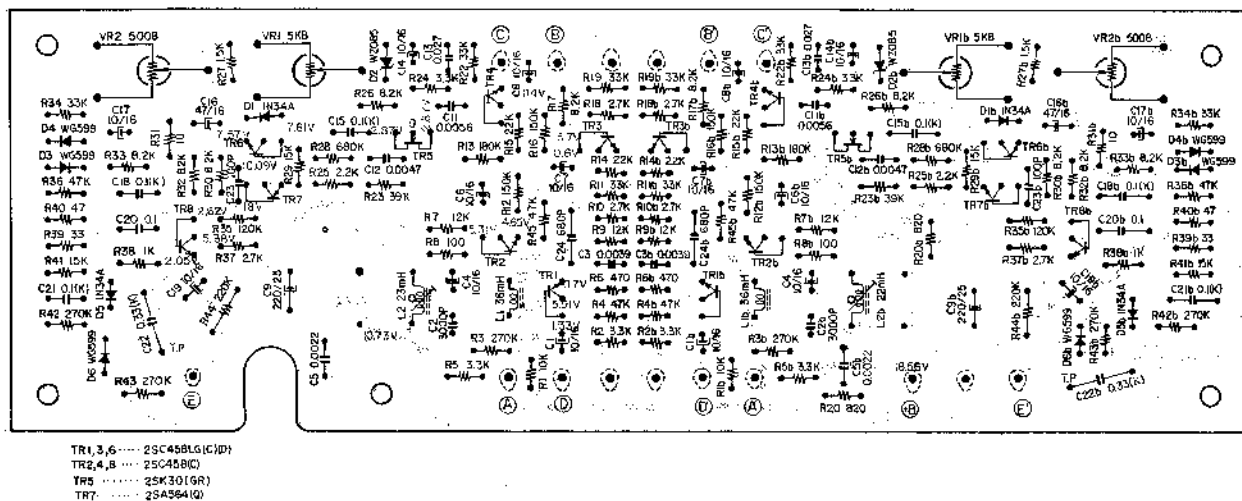
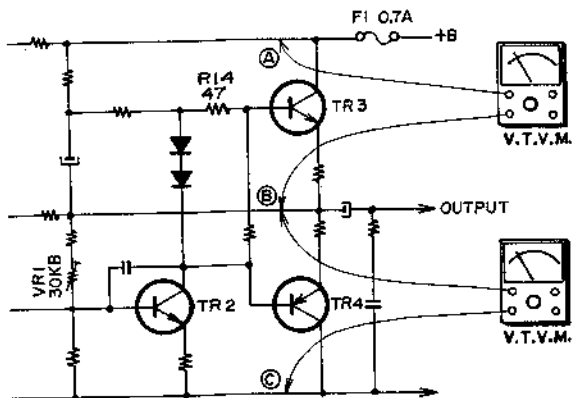

Fig. 31 DOLBY AMP. P.C. BOARD CG-5202 (Reverse Side)

- b) Turn Dolby Amp. P.C. Board Dolby Amp. Gain Adjustment Semi-fixed Resistors VR2 500 B (left ch.) VR2b 500 B (right ch.) and FET Gate Bias Adjustment Semi-fixed Resistors VR1 5 kB (left ch.) VR1b 5 kB (right ch.) as far as they will go in the direction of the arrows shown in Fig. 30.
- c) Turn Dolby Switch SW5 to OFF position and, as shown in Fig. 31, ground Test Point "TP" (FET GATE).
- d) Set the oscillation frequency of the Audio Frequency Oscillator to 5 kHz and supply this signal to the line input.
- e) Set recorder to recording mode, and adjust the Attenuator to obtain a 2 dB line output level.
- f) At this condition, further adjust the Attenuator so that the line output level at Point (D) shown in Fig. 30 is -28.5 dB. At this time, confirm that the level at Point (B) shown in Fig. 30 is -28.5 ± 0.5 dB.
- g) Turn Dolby Switch SW5 to ON position. At this time, adjust Dolby Amp. Gain Adjustment Semi-fixed Resistors VR2 500 B (left ch.) VR3b 500 B (right ch.) until the voltage at Point (B) shown in Fig. 30 is increased by 10 dB.
- h) Disconnect ground from Test Point "TP" (FET Gate). At this time, adjust FET Gate Bias Adjustment Semi-fixed Resistors VRI 5 kB (left ch.) VRIb 5 kB (right ch.) so that the voltage at Point (B) shown in Fig. 30 is reduced by 2 dB.



POWER AMP CIRCUIT

Fig. 32 POWER AMP. CIRCUIT

8. POWER AMPLIFIER VOLTAGE ADJUSTMENT

As shown in Fig. 32, connect a V.T.V.M. between points (A) (B) as well as between (B) (C) and adjust Variable Resistor VR1 (30 kΩ) so that the V.T.V.M. indication is half the value of the supply voltage. There is no way to adjust the "no signal current" but the correct "no signal current" is 5 mA. When a power transistor is replaced and a signal introduced, if cross-over distortion is considerable, it can be reduced by Changing Resistor R14 47 to about 33.

VII. MOTOR AND COIL WINDING D. C. RESISTANCE

Parts	Type	D.C. Resistance	Remarks
MOTOR	1B-440	approx' 110Ω approx' 65Ω	between WHT/ORG & ORG between WHT/BLK & BLK
REC./P.B. HEAD	P4-340	approx' 180Ω	1 channel
ERASE HEAD	ME-136(A)	8Ω±30%	
PLUNGER SOLENOID	0730THTI	15Ω±10%	
HEAD PHONE OUTPUT TRANS	N16-535S	565Ω±15% 0.95Ω±15%	Primary Secondary
OSCILLATOR COIL	OT-903	approx' 0.04Ω approx' 0.14Ω approx' 0.65Ω	between 1 & 3 between 4 & 6 between 7 & 9

VIII. COMPOSITE VIEWS OF COMPONENTS

I. PRE AMP. P.C. BOARD CG-5402

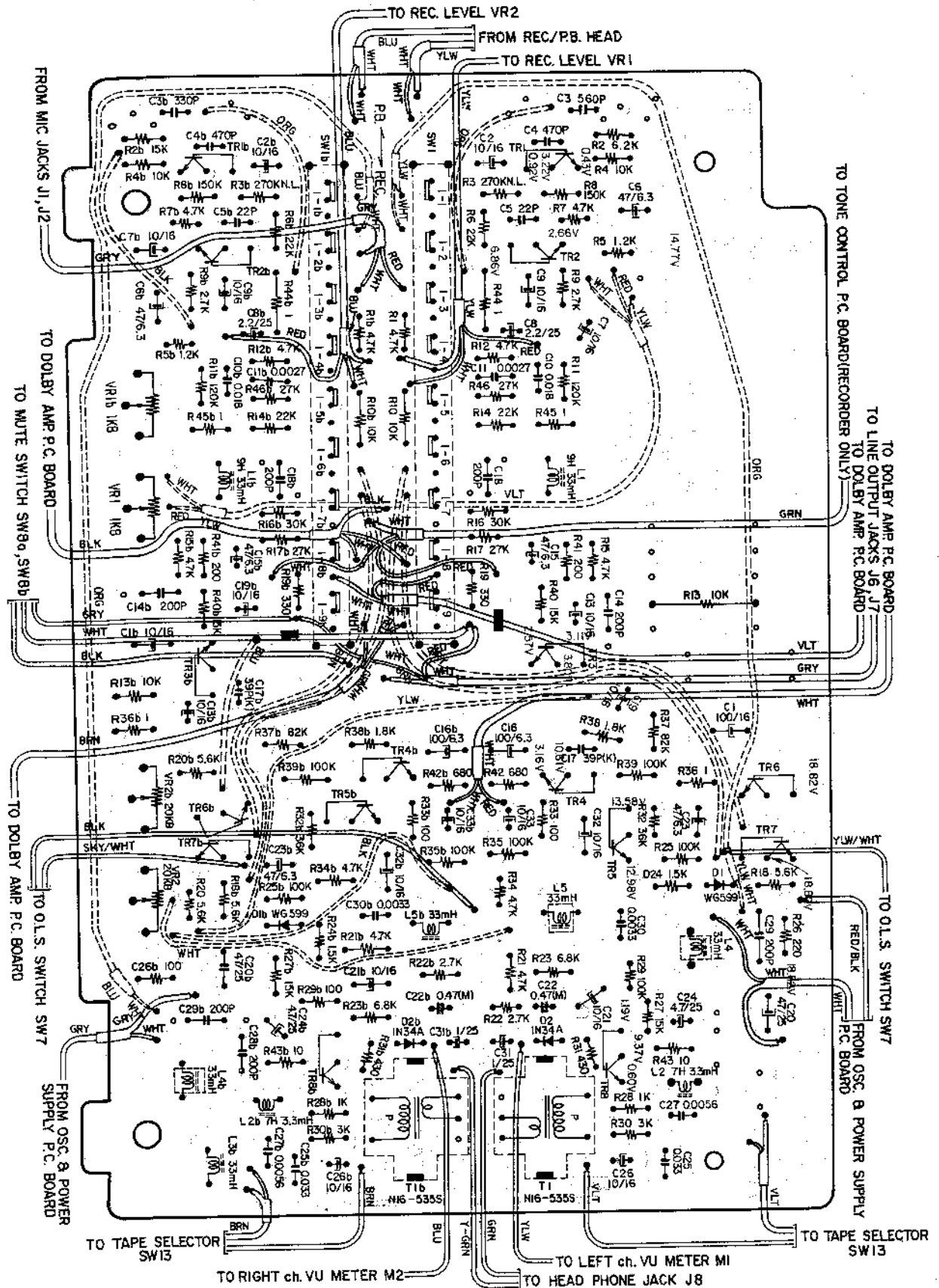

2. MAIN AMP. P.C. BOARD CG-5009

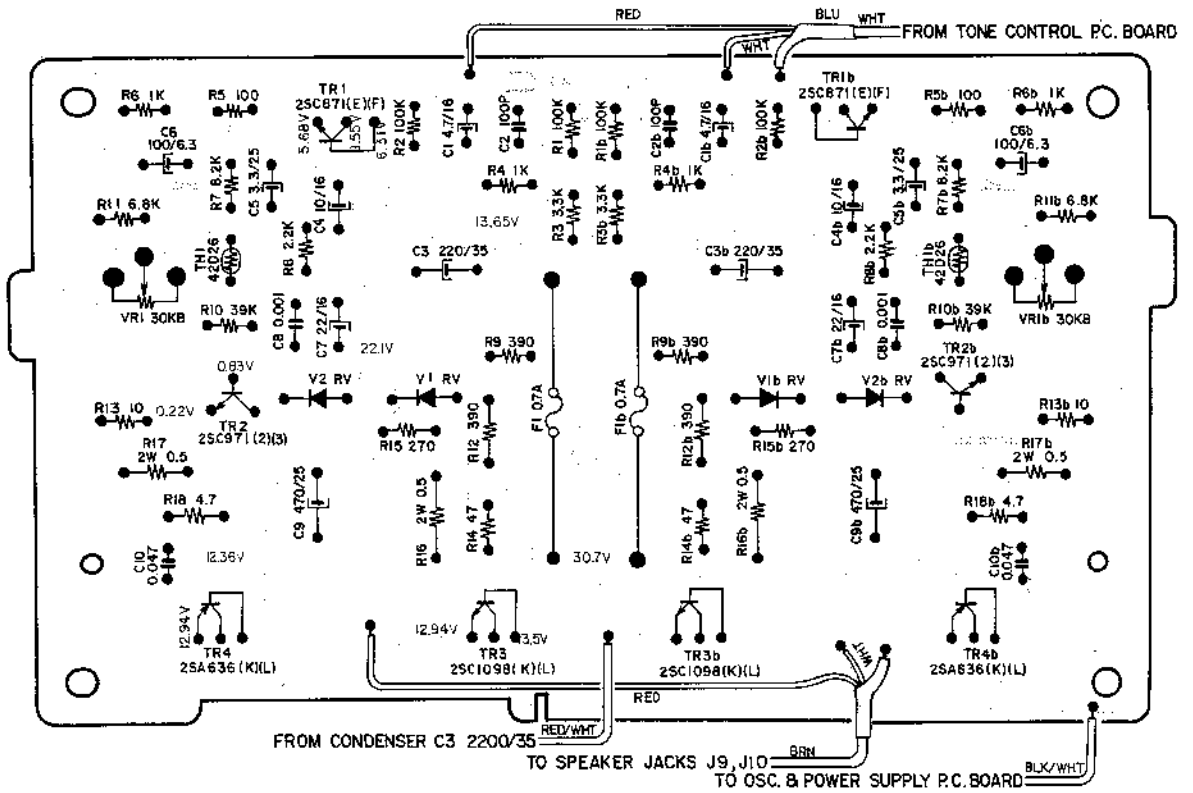

3. MAIN AMP. P.C. BOARD CG-5403

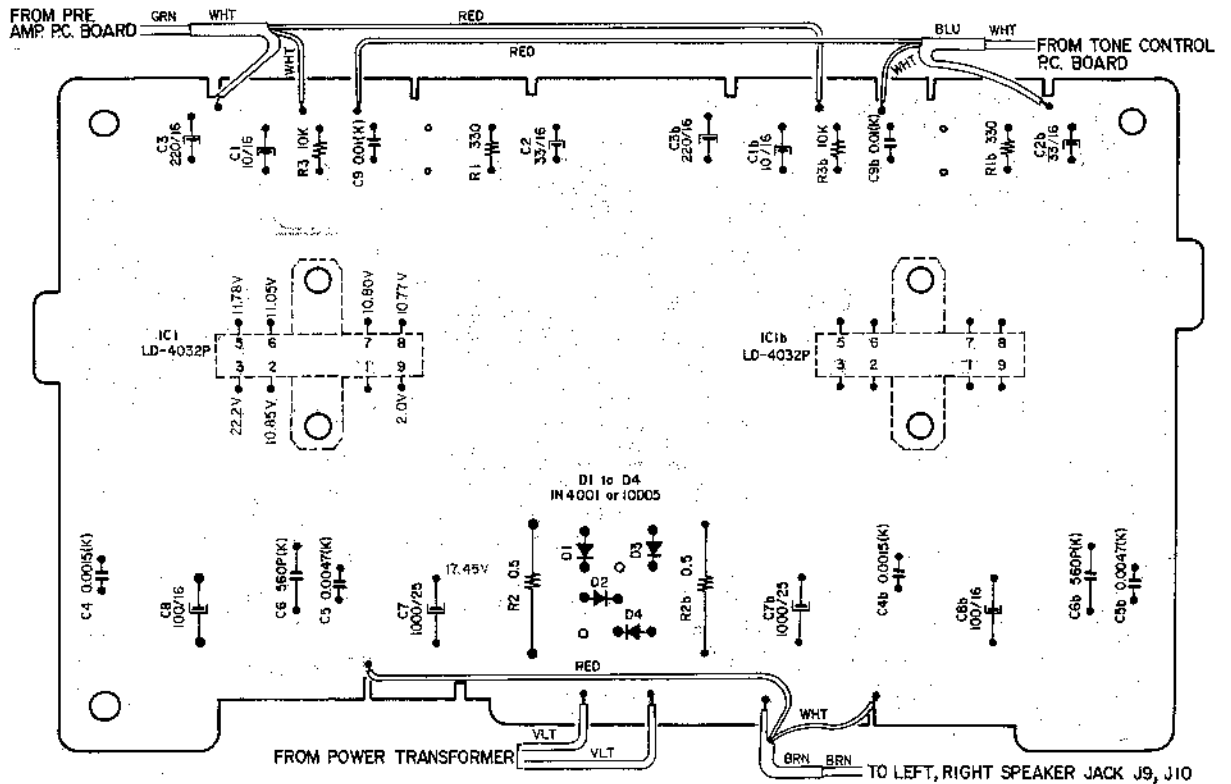

4. SYS. CON. P.C. BOARD CG-1413

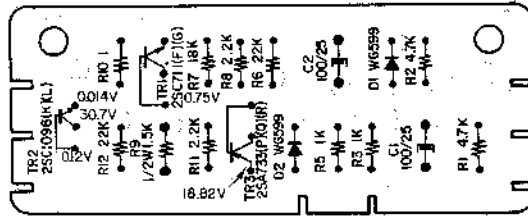

5. SYS. CON. P.C. BOARD CG-1401

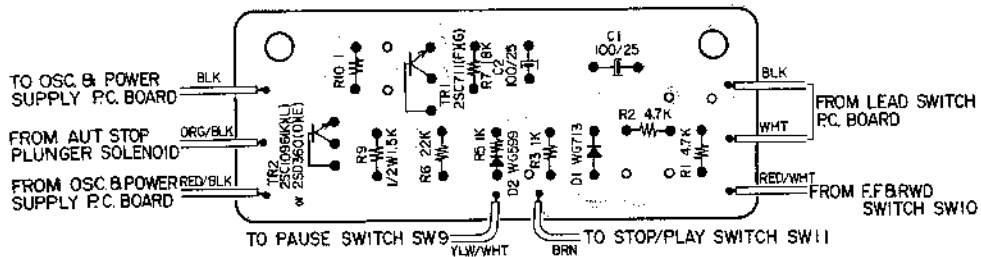

6. LEAD SWITCH P.C. BOARD CG-1229

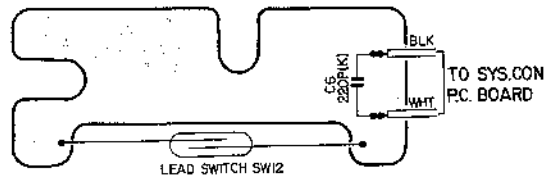

7. TONE CONTROL P.C. BOARD CG-5207

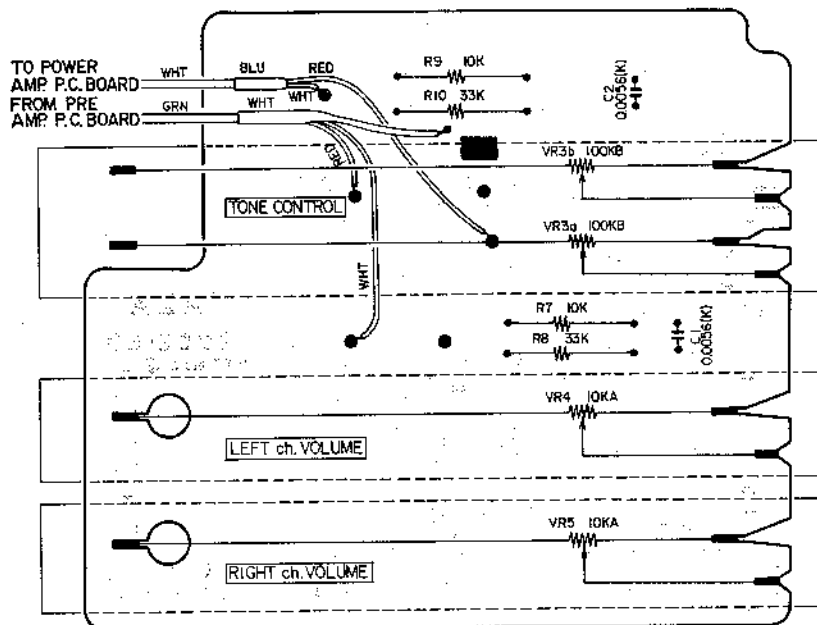

8. OSC. & POWER SUPPLY P.C. BOARD CG-5401

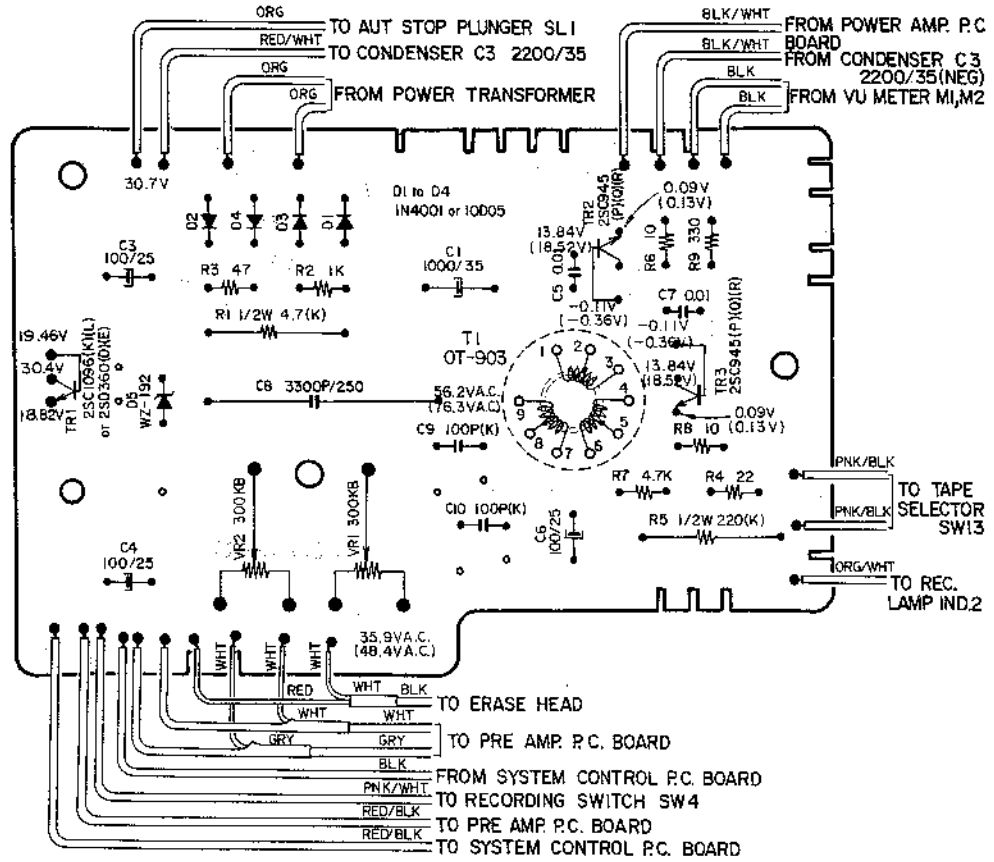

9. FUSE P.C. BOARD CG-1306J

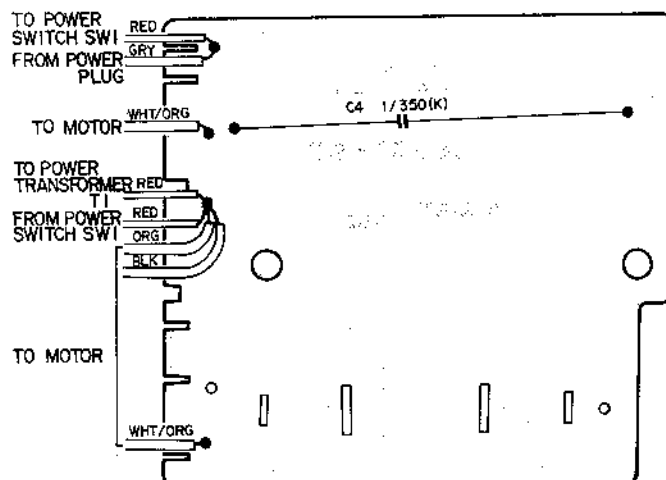

SECTION 2
PARTS LIST

TABLE OF CONTENTS

FIG. 1	HEAD BASE BLOCK	28
FIG. 2	MOTOR BLOCK	29
FIG. 3	REEL TABLE BLOCK	30
FIG. 4	MECHANISM ASSEMBLY BLOCK (1)	30
FIG. 5	MECHANISM ASSEMBLY BLOCK (2)	33
FIG. 6	AMP. CHASSIS & POWER SUPPLY BRACKET BLOCK	35
FIG. 7	VU CHASSIS & REAR CHASSIS BLOCK	36
FIG. 8	DOLBY P.C. BOARD (CG-5202) BLOCK	37
FIG. 9	MAIN AMP. P.C. BOARD (CG-5009) BLOCK	38
FIG. 10	MAIN AMP. P.C. BOARD (CG-5403) BLOCK (GXC-38 UL, J)	39
FIG. 11	PRE AMP. P.C. BOARD (CG-5402) BLOCK	41
FIG. 12	SYSTEM CONTROL P.C. BOARD (CG-1413) BLOCK ..	42
FIG. 13	POWER SUPPLY P.C. BOARD (CG-5401) BLOCK	43
FIG. 14	FINAL ASSEMBLY BLOCK	45
INDEX	46

HOW TO USE THIS PARTS LIST

1. This parts list is compiled by various individual blocks based on assembly process.
2. When ordering parts, please describe parts number, serial number, and model number in detail.
3. How to read List

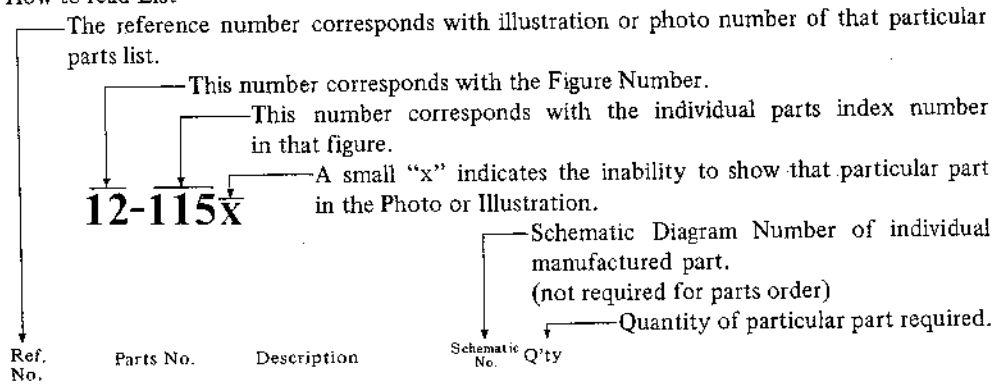

Ref. No.	Parts No.	Description	Schematic No.	Q'ty
FLYWHEEL BLOCK #13				
12-115x	800425	Flywheel Block Assy. Comp.	RDG #13	1
12-116	244506	Flywheel Only	RD-233	1
12-117x	244754	Felt, Flywheel	RD-275	1
12-118	251324	Main Metal Case	RD-236	1
12-119	253080	Main Metal	RD-237	1

4. The symbol numbers shown on the P.C. Board list can be matched with the Composite Views of Components of the Schematic Diagram or Service Manual.
5. The indications of Resistors and Capacitors in the photos of P.C. Board are being eliminated.
6. The shape of the parts and parts name, etc. can be confirmed by comparing them with the parts shown on the Electrical Parts Table of P.C. Board.
7. Both the kind of part and installation position can be determined by the Parts Number. To determine where a parts number is listed, utilize Parts Index at end of Parts List.
It is necessary first of all to find the Parts Number. This can be accomplished by using the Reference Number listed at right of parts number in the Parts Index. (meaning of ref. no. outlined in Item 3 above).
8. Utilize separate "Price List for Parts" to determine unit price. The most simple method of finding parts Price is to utilize the reference number.

ELECTRICAL PARTS TABLE











<p>Because the indication of resistors and capacitors in the P.C. Board photos are being eliminated, please confirm parts name and shape by comparing them with the parts shown in this table.</p>	1	2	3	
	 Solid Resistor	Stopper Type  Insulator Type Carbon Resistor	 Metal Oxide Film Resistor	
	4	5	6	7
	 Cement Resistor	 Wire-Wound Resistor	 Thermister	 Enamel Resistor
	1	2	3	4
	 MP Capacitor (Tubular Type)	 Plastic Capacitor	 Mylar Capacitor	 VFM (Hi-Q) Capacitor
	5	6	7	8
	 Mylar Capacitor	 Tantalum Capacitor	 Oil Capacitor (Tubular Type)	Vertical Type  Tubular Type Styrol Capacitor
	9	10	11	12
	 Electrolytic Capacitor (Tubular Type)	Vertical Type  Tubular Type Electrolytic Capacitor	 Ceramic Capacitor	 Metalized Mylar (Paper) Capacitor
	13	VR		
	 Trimmer Condenser	 Semi-Fixed Volume		
L	TR			
 Ferri Inductor	 Transistor			
CR	D			
 Spark Quencher	 Diode (Silicon, Zener, Germanium)			

FIG. 1 ILLUSTRATION OF HEAD BASE BLOCK

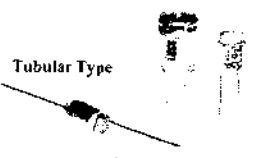

HEAD BASE BLOCK

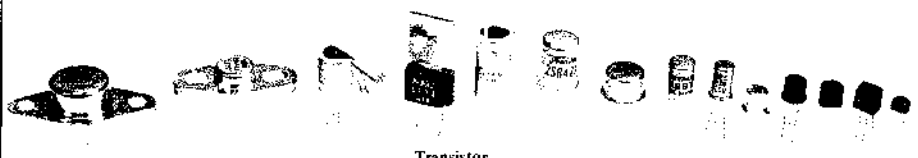
Ref. No.	Parts No.	Description	Schematic No.	Q'ty
1-1x	BH554714	Head Base Block Comp.	CG-5,6	1
1-2	HZ457323	Head Base, w/shaft	CG-0001	1
1-3	HL457391	Pinch Roller Arm	CG-0010	1
1-4	MR468292	Pinch Roller (CG) D=13	CG-0032	1
1-5	MS389981	Pinch Roller Shaft	CS-0011	1
1-6	ZW391397	'E' Ring 1.2M	6-1-9	1
1-7	ZG457380	Pinch Roller Spring	CG-0009	1
1-8	ZW270088	'E' Ring 1.9M	6-1-9	1
1-9	ZG457378	Cassette Retaining Spring (2)	CG-0008	1
1-10	HZ457367	Cassette Stop Base	CG-0007	1
1-11	ZW417137	Screw, binding head 3x4		2
1-12	ZW462881	Screw, binding head 2.3x12		1
1-13	ZG465636	Angle Adjust Spring	CG-0029	1
1-14	HP536095	REC./P.B. HEAD P4-340		1
1-15	ZW414235	Washer A (0.1t)	CS-0025	1
1-16	ZW414246	Washer B (0.15t)	CS-0025	1
1-17	UM366625	PC Tape Guide	RCC-1012	1
1-18	ZW461395	Screw, round head 2x3		2
1-19	ZW273688	Nut M2.3		1
1-20	ZW417273	Screw, binding head 2.3x4		2
1-21x	ZW273633	Earth Lug M2.3		1
1-22	ZW417227	Screw, binding head 2.3x5		2
1-23	UM399071	Head Wiring Hook	CS-0021	1
1-24	HE554646	ERASE HEAD B ME-136B		1
		(red) 37-2-1		1

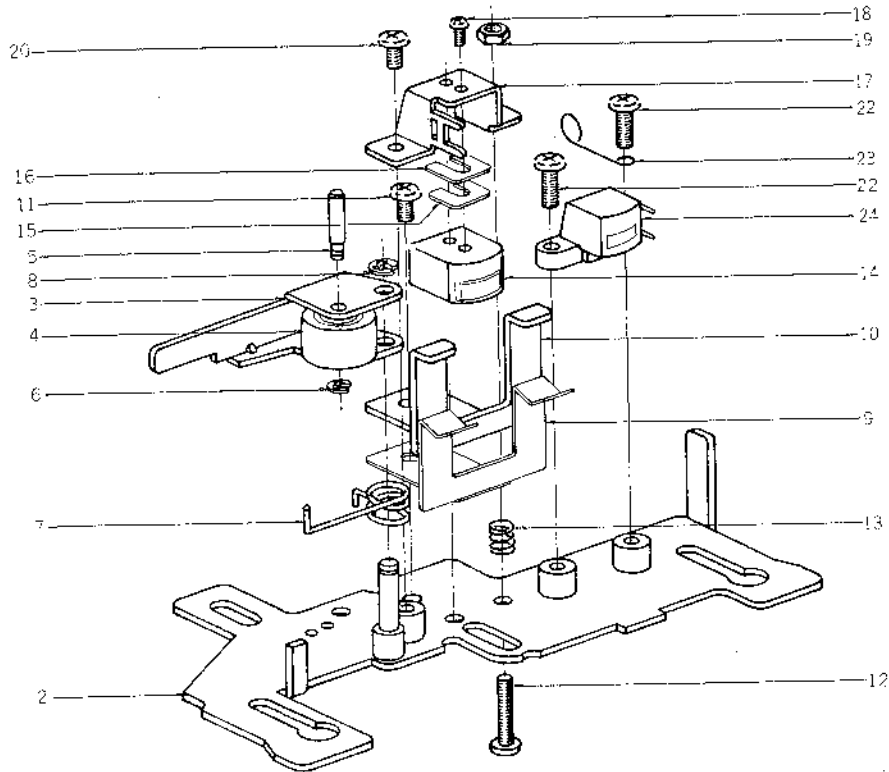
When ordering parts, please describe Parts Number, Serial Number, and Model Number in detail.

FIG. 2 ILLUSTRATION OF MOTOR BLOCK

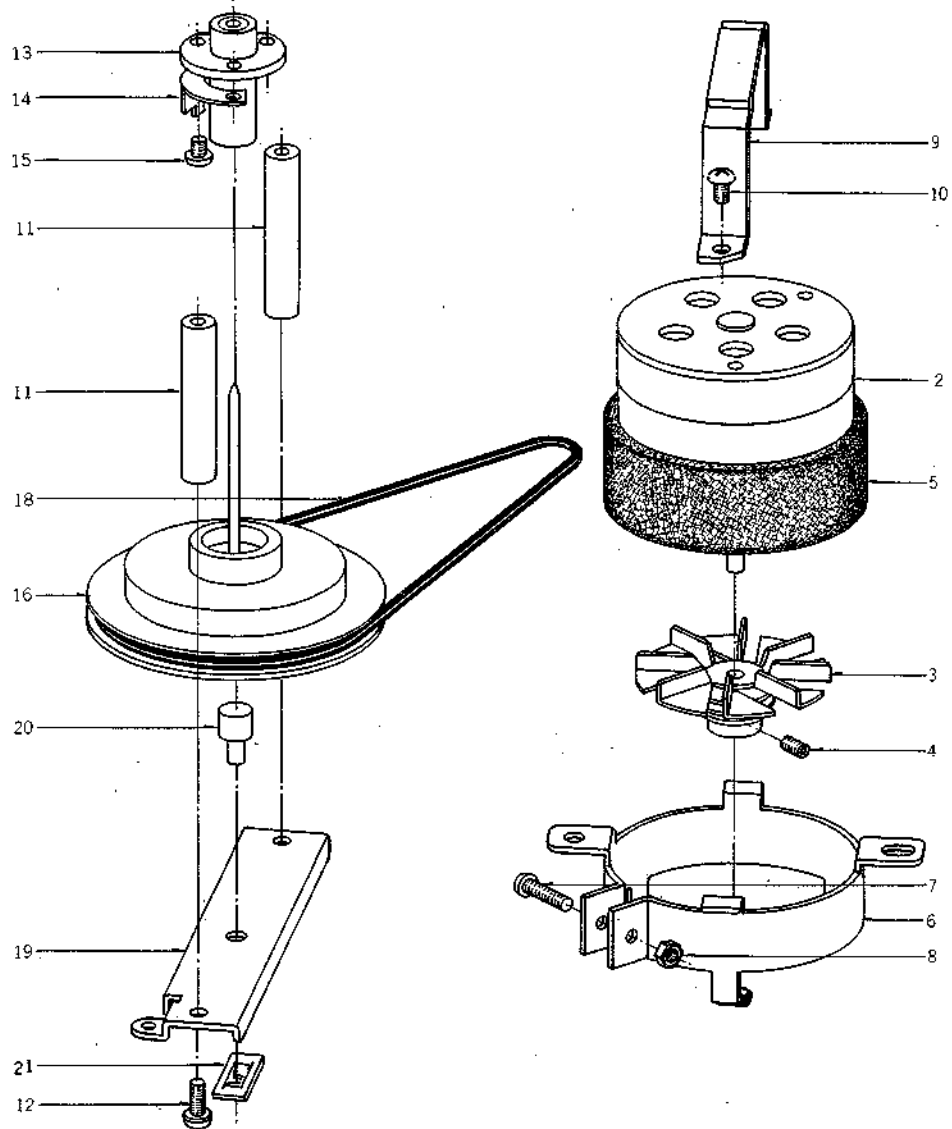

MOTOR BLOCK

Ref. No.	Parts No.	Description	Schematic No.	Q'ty	Ref. No.	Parts No.	Description	Schematic No.	Q'ty
2-1x	BM510107	Motor Block Comp.	CG-3,4,5,6	1	2-11	UM456671	Capstan Supporting Prop	CG-1016	2
2-2	BM510118	Motor IC-414	9-2-1	1	2-12	ZW417025	Screw, binding head 3x8, w/washer		4
2-3	MZ510017	Motor Fan, w/pulley B	CG-7308	1	2-13	BC456625	Capstan Metal Case, w/metal	CG-1017	1
2-4	ZW356804	Set Screw, hexagon socket 3x4(cup)		2	2-14	ZW464692	Screw, binding head 2.3x6		3
2-5	UM516352	Dust-proof Rubber B	CG-1236	1	2-15	UM494987	Take-up Spring Hook	CG-1101	1
2-6	UM516306	Motor Mt. Metal B	CG-1234	1	2-16	BF456658	Flywheel, w/capstan shaft	CG-1021	1
2-7	ZW417148	Screw, binding head 3x15		1	2-17x	ZW461272	Washer (Polyslider)D3x5x0.13t		1
2-8	ZW273756	Nut M3		1	2-18	MB456660	Capstan Belt D106x1.4x1.4	CG-1023	1
MECH. ASSEMBLY BLOCK									
2-9	UM510041	Reinforcement Angle	CG-1305	1	2-19	UM456682	Capstan Supporting Plate	CG-1022	1
2-10	ZW462925	Tapping Screw #2 4x8(BR)		4	2-20	UM387268	Flywheel Support	CS-1115	1
					2-21	ZW478991	Speed Nut (P-type)4M	7-1-48	1

When ordering parts, please describe Parts Number, Serial Number, and Model Number in detail.

FIG. 3 ILLUSTRATION OF

REEL TABLE BLOCK

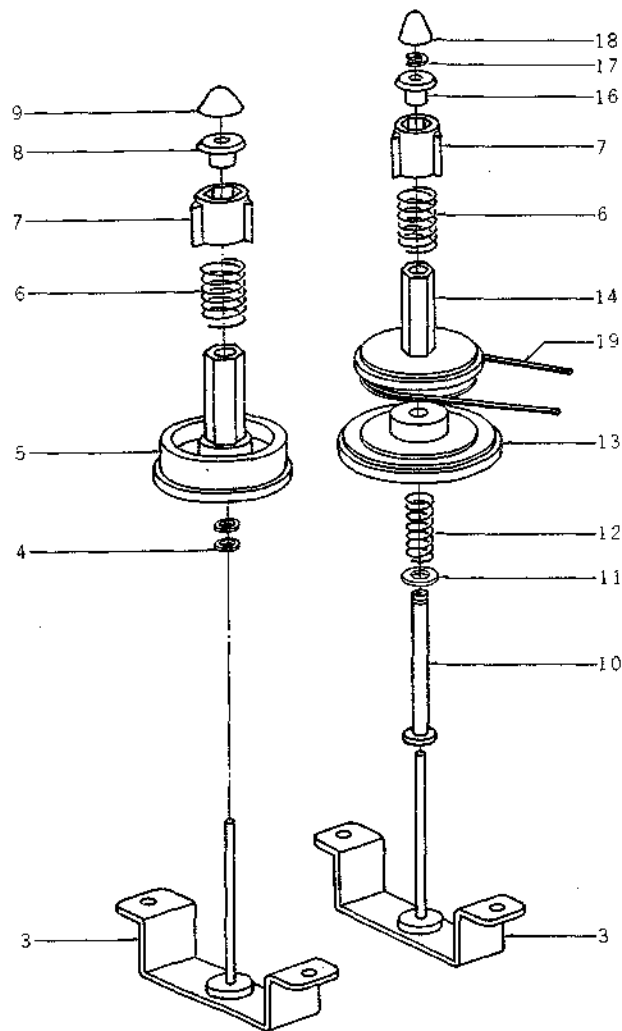

REEL TABLE BLOCK

Ref. No.	Parts No.	Description	Schematic No.	Q'ty
3-1x	BR451697	Supply Reel Table Block	Comp. CG,CT	1
3-2x	BR451686	Take-up Reel Table Block	Comp. CG,CT	1
3-3	UM457312	Reel Table Bracket, w/shaft	CG-2001	2
3-4	ZW364342	Washer (Polyslider)	D1.7x3.2x0.25t	4
3-5	UM389790	Supply Reel Table Comp.	CS-2016B	1
3-6	ZG385075	Reel Table Spring	CS-2014	2
3-7	ZG370361	C type Reel Table Blade	RCC-1345	2
3-8	UC370348	C type Reel Table Bush	RCC-1343	1
3-9	UC370372	C type Reel Shaft Cap	RCC-1346	1
3-10	MS387573	Take-up Reel Table Shaft	CS-2007	1
3-11	ZW355307	Washer (BSP)D2.6x6.9x0.51		1
3-12	ZG387584	Clutch Spring	CS-2008	1
3-13	MR387606	Take-up Reel Table Pulley	Comp. CS-2009B	1
3-14	UM387630	Take-up Reel Table Comp.	CS-2012B	1
3-15x	UM387617	Clutch Felt	CS-2011	1
3-16	UM387641	Take-up Reel Table Bush	CS-2015	1
3-17	ZW270088	'E' Ring 1.9M	6-1-9	1
3-18	UM394200	Take-up Reel Cap	CS-2105	1
3-19	MB456917	Counter Belt D60x1x1	CG-1038	1
3-20x	ZW417251	Screw, binding head 2.3x3		4

MECHANISM ASSEMBLY BLOCK (1)

Ref. No.	Parts No.	Description	Schematic No.	Q'ty
OPERATION BUTTON BLOCK				
4-1x	BZ517858	Operation Button Block Comp.	CG-4,5,6,7	1
4-2	UM498216	Operation Button Holder B, w/shaft	CG-2063	1
4-3	SB457413	Operation Button A	CG-2006	1
4-4	SB461406	Operation Button B, w/pin C	CG-2006	1
4-5	MS457435	Button Shaft	CG-2004	1
4-6	ZW290283	'U' Ring 2.85M	6-1-1	2
4-7	UM457424	Button Lever	CG-2005	2
4-8	ZG514675	Pause Lever Spring	CG-2209	1
4-9	UM515575	Switch Lock Cam B	CG-2301	1
4-10	ZG514440	Button Lock Spring B	CG-2303	1
4-11	ZW452373	Washer (SPC)D3x8x0.5t		1
4-12	ZW270088	'E' Ring 1.9M	6-1-9	1
4-13	SK543172	Operation Knob	CG-2402	2
4-14	ES494188	Micro Switch SS-5GL-13	25-1-25	1
4-15x	ZW461261	Screw, binding head 2.3x8		1
4-16x	ZW417328	Screw, binding head 2.3x10		1
4-17x	ZW273688	Nut M2.3		1
SWITCH TABLE BLOCK				
4-18x	BZ517860	Switch Table Block Comp.	CG-4,5,6,7	1
4-19	UM452834	Switch Table A	CG-5018	1
4-20	ES490432	Slide Switch SSD04200 (SL type)	25-3-74	2
4-21	ZW379405	ISO Screw, binding head 3x6		4
4-22x	EZ328320	Nylon Clip HP-5N	2-7-39	1
4-23x	ZW447772	Tapping Screw #2 3x6(BR)		1
MECH. FRAME BLOCK				
4-24	MZ456480	Mech. Frame, w/shaft	CG-1001	1
4-25	UM483930	P.C. Board Retaining Plate	CT-1004	2
4-26	UM483941	Retaining Foot B	CT-1002	2
4-27	ZW447772	Tapping Screw #2 3x6(BR)		8
4-28	UM456928	Brake Shoe	CG-1039	1
4-29	ZG456930	Brake Spring	CG-1040	1
4-30	UM457018	Rec. Slide	CG-1049	1
4-31	ZW259986	Washer (Nylon)D5.1x10.3x1t		3
4-32	ZW290283	'U' Ring 2.85M	6-1-1	17
4-33	UM456963	Rewind Slide	CG-1043	1
4-34	UM456941	Brake Slide	CG-1041	1
4-35	UM456952	F.Fwd Slide	CG-1042	1
4-36	ZG516418	Eject Spring	CG-1238	1
4-37	UM457108	Eject Slide (2)	CG-1059	1
4-38	ZW259885	Washer (PBP)D5.1x10.3x0.1t		1
4-39	UM457097	Pause Slide	CG-1058	1
4-40	UM457121	Eject Slide (1)	CG-1061	1
4-41	ZW417273	Screw, binding head 2.3x4		2
4-42	UM457132	Eject Lever	CG-1062	1
4-43	UM457198	Cassette Guide	CG-1071	2
4-44	ZW514697	Head Return Spring	CG-1308	1
4-45	UM457110	Pause Lever	CG-1060	1
4-46	ES491962	Leaf Switch 2SB-2B-14	25-10-13	1
4-47	ZW447772	Tapping Screw #2 3x6(BR)		10
4-48	UM457075	Switch Plate	CG-1056	1
4-49	ES389700	Micro Switch SS-5	25-1-19	1
4-50	ZW461261	Screw, binding head 2.3x8		2
4-51	UM457233	Cassette Base	CG-1073	1
4-52	ZG457244	Cassette Retaining Spring	CG-1074	1
4-53	UM457255	Rec. Safety Pin	CG-1075	1
4-54	ZW290283	'U' Ring 2.85M	6-1-1	3
4-55	ZG367301	Click Spring	RCC-1259	1
4-56	UM457200	Cassette Base Bracket, w/pin	CG-1063	2
4-57x	ZW273778	Earth Lug M3		1
4-58	UM483906	Rec. Safety Lever	CT-1003	1
4-59	ZG387821	Rewind Spring	CS-2033	1
4-60	MC516014	Counter MP-390-94S (w/base)	9-1-26	1
4-61x	UM516025	Magnet TG0034	5-1-8	1
4-62x	UM515935	Bush	CG-1235	1
4-63	ZW483456	Screw, countersunk head 2.3x4		2
4-64	EP494425	Plunger 0730THTI	44-1-48	1
4-65	UM494392	Plunger Retaining Plate	CG-1203	1
4-66x	ZW481645	Screw, binding head 2.6x3		2
4-67	UM494291	Joint	CG-1205	1

When ordering parts, please describe Parts Number, Serial Number, and Model Number in detail.

FIG. 4 ILLUSTRATION OF MECHANISM ASSEMBLY BLOCK (1)

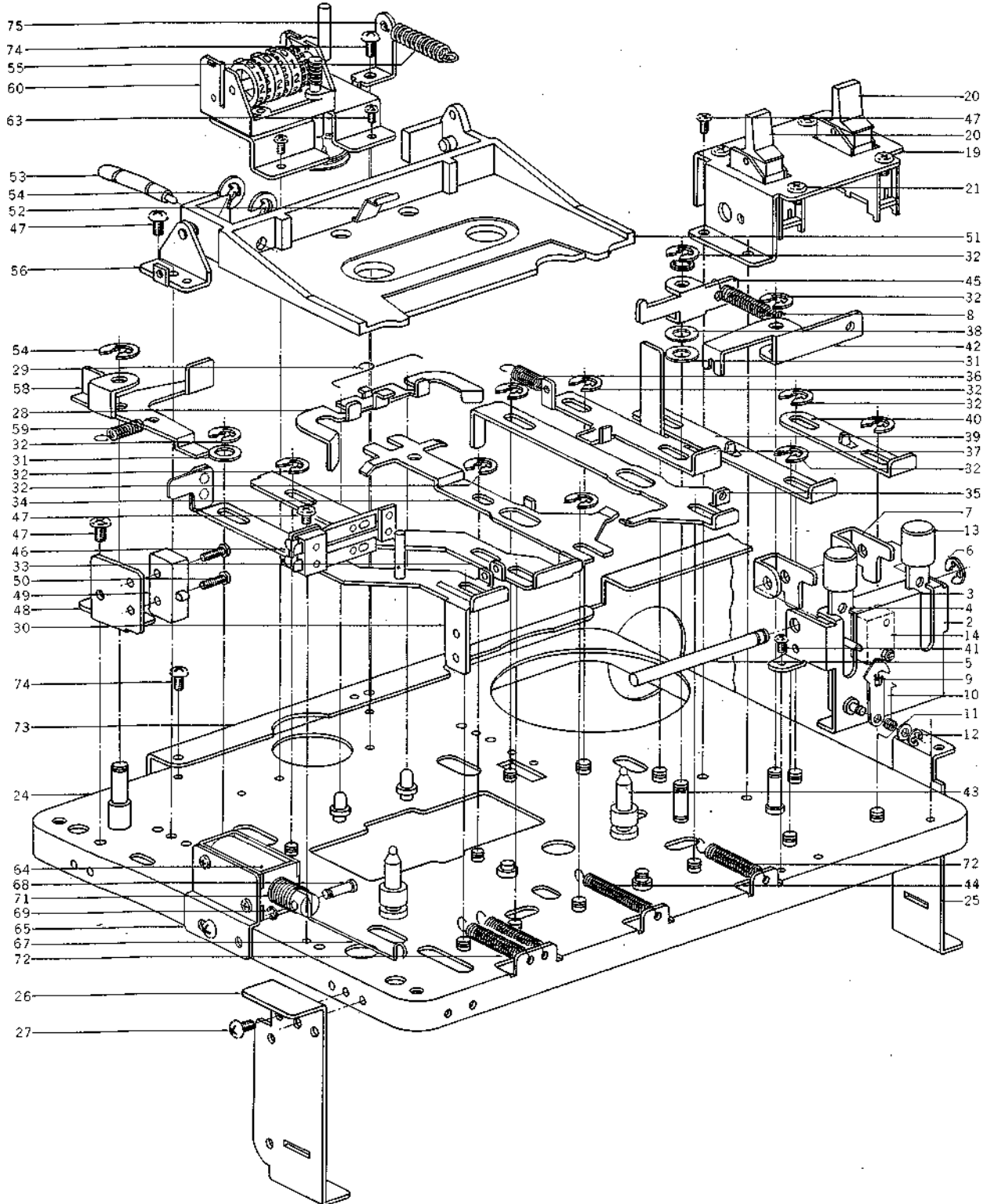

Ref. No.	Parts No.	Description	Schematic No.	Q'ty
4-68	UM494414	Joint Pin	CG-1206	1
4-69	ZW270088	'E' Ring 1.9M	6-1-9	1
4-70x	ED494583	Silicon Diode 10D05	45-2-42	1
4-71	ZG494403	Return Spring	CG-1204	1
4-72	ZG456186	Lock Lever Spring	CC-1119	3
4-73	UM518850	Power Supply Bracket D	CG-5408	1
4-74	ZW447772	Tapping Screw #2 3x8(BR)		5
4-75	UM457266	Spring Hook	CG-1077	1

When ordering parts, please describe Parts Number, Serial Number, and Model Number in detail.

FIG. 5 (A) ILLUSTRATION OF MECHANISM ASSEMBLY BLOCK (2)

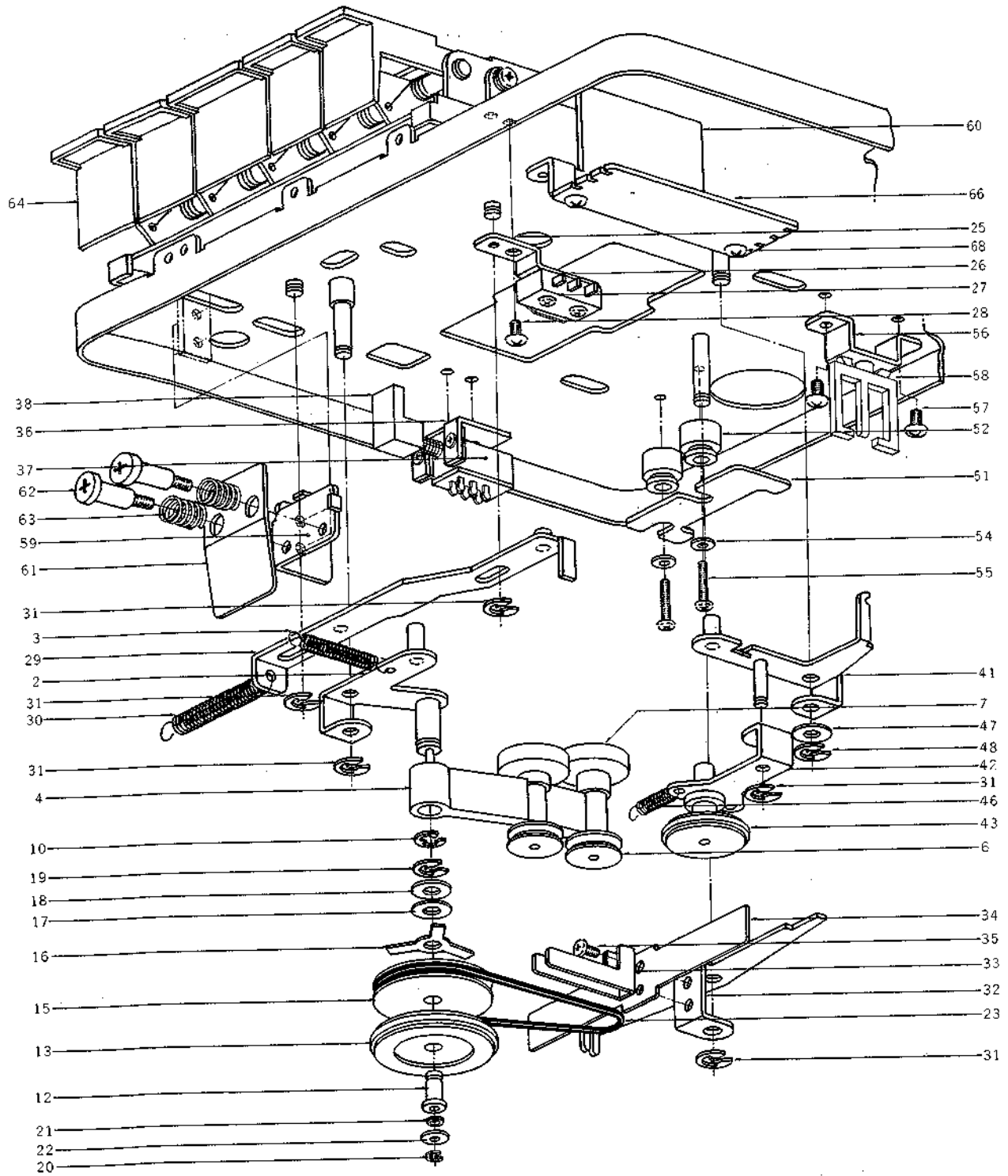

**FIG. 5 (B) PHOTO OF
MECHANISM ASSEMBLY BLOCK (2)**

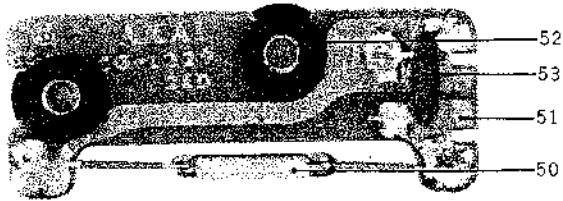

MECHANISM ASSEMBLY BLOCK (2)

Ref. No.	Parts No.	Description	Schematic No.	Q'ty
WIND IDLER BLOCK				
5-1x	BZ459966	Wind Idler Block Comp.	CG,CT	1
5-2	UM456783	Wind Lever (1), w/shaft	CG-2009	1
5-3	ZG345262	Gear-off Lever Spring	10R-390	1
5-4	UM456827	Wind Lever (2), w/metal	CG-2015	1
5-5x	MS456851	Wind Pulley Shaft (1) (L=22.5)	CG-2018	1
5-6	MR456838	Wind Pulley (1)	CG-2016	2
5-7	MR456840	Wind Pulley (2)	CG-2017	2
5-8x	ZW381644	Washer (Polyslider) D2.1x4.0x0.13t		4
5-9x	MS456862	Wind Pulley Shaft (2) (L=28.5)	CG-2018	1
5-10	ZW270123	'E' Ring 4M	6-1-9	1
5-11x	UM462690	Wind Wheel Sub Comp.		1
5-12	UM461878	Wheel Collar	CG-2026	1
5-13	UM461880	Wind Wheel (1), w/ring	CG-2023	1
5-14x	UM461586	Clutch Felt	CG-2025	1
5-15	UM461891	Wind Wheel (2)	CG-2024	1
5-16	ZG459224	Clutch Spring	CG-2021	1
5-17	ZW259795	Washer (SUP)D4.3x11x0.13t		1
5-18	ZW421007	Washer (SUP)D4.3x11x0.25t		1
5-19	ZW290283	'U' Ring 2.85M	6-1-1	1
5-20	ZW391397	'E' Ring 1.2M	6-1-9	1
5-21	ZW474581	Washer (Teflon) D2.05x3.5x0.2t		1
5-22	ZW474592	Washer (Teflon)D2.05x7x0.2t		1
5-23	MB456895	Wind Belt	CG-1035	1
5-24x	ZW474603	Washer (PBP)D4.1x13x0.2t		1
MECH. FRAME BLOCK				
5-25	UM494190	Detector Switch Base	CG-1215	1
5-26	ES477966	Micro Switch SS-5L	25-1-23	1
5-27	ZW461261	Screw, binding head 2.3x8		2
5-28	ZW447772	Tapping Screw #2 3x6(BR)		1
5-29	UM456996	Wind Slide, w/pin	CG-1046	1
5-30	ZG224796	New Spring D	MH-142	1
5-31	ZW290283	'U' Ring 2.85M	6-1-1	5
5-32	UM456974	Wind Lever (3)	CG-1044	1
5-33	ZG456985	Wind Spring	CG-1045	1
5-34	ZG460484	Wind Plate Spring	CG-1083	1
5-35	ZW417273	Screw, binding head 2.3x4		2
5-36	UM498892	Switch Holder	CG-3304	1
5-37	ES539043	Push Switch SPJ-10108	25-5-92	1
5-38	SB499195	Switch Button	CG-3305	1
5-39x	ZW464703	Screw, binding head 2x4		2
5-40x	ZW442585	Screw, binding head 2.6x4		2
5-41	UM456693	Take-up Lever (1), w/shaft	CG-1024	1
5-42	UM456726	Take-up Lever (2), w/metal	CG-1028	1
5-43	UM456750	Take-up Wheel, w/shaft	CG-1031	1
5-44x	ZW474581	Washer (Teflon) D2.05x3.5x0.2t		1
5-45x	MR456761	Take-up Pulley	CG-1032	1
5-46	ZG469315	Take-up Lever Spring	CG-1091	1
5-47	ZW461248	Washer (PBP)D4.3x11x0.35t		1
5-48	ZW290283	'U' Ring 2.85M	6-1-1	1
5-49x	ZW530504	Oil Cut Washer	CG-1102	1
5-50	ES516036	Lead Switch ORD-225	25-11-1	1

Ref. No.	Parts No.	Description	Schematic No.	Q'ty
5-51	EA516047	Lead Switch P.C. Board	CG-1229	1
5-52	UM515518	Switch Table Cushion	CG-1228	2
5-53	EC290564	VFM 220PF(K) 50WV	24-6-2	1
5-54	ZW516251	Washer (SPC)D2.4x5.8x0.4t		2
5-55	ZW462881	Screw, binding head 2.3x12		2
5-56	UM518117	Retaining Plate	CG-1404	2
5-57	ZW447772	Tapping Screw #2 3x6(BR)		10
5-58	EJ510333	Wire Clip	2-7-17	3
5-59	UM457053	Rec. Bracket	CG-1051	1
5-60	UM518106	P.C. Board Table	CG-1403	1
5-61	ZG512842	Rec. Spring B	CG-1226	1
5-62	ZW478697	CG Graduated Screw	CG-1093	2
5-63	ZG494381	Rec. Cramp Spring B	CG-1218	2
5-64	ES517151	Keyboard Switch C	25-5-77	1
5-65x	ZW273767	Earth Lug D3x20L		1
5-66	BA519131	Sys. Con. P.C. Board Comp. (CG-1413)		1
5-67x	BA557355	Sys. Con. P.C. Board Comp. (CG-1413) (44D-J)		1
5-68	ZW447772	Tapping Screw #2 3x6(BR)		2

FIG. 6 ILLUSTRATION OF AMP. CHASSIS & POWER SUPPLY BRACKET BLOCK

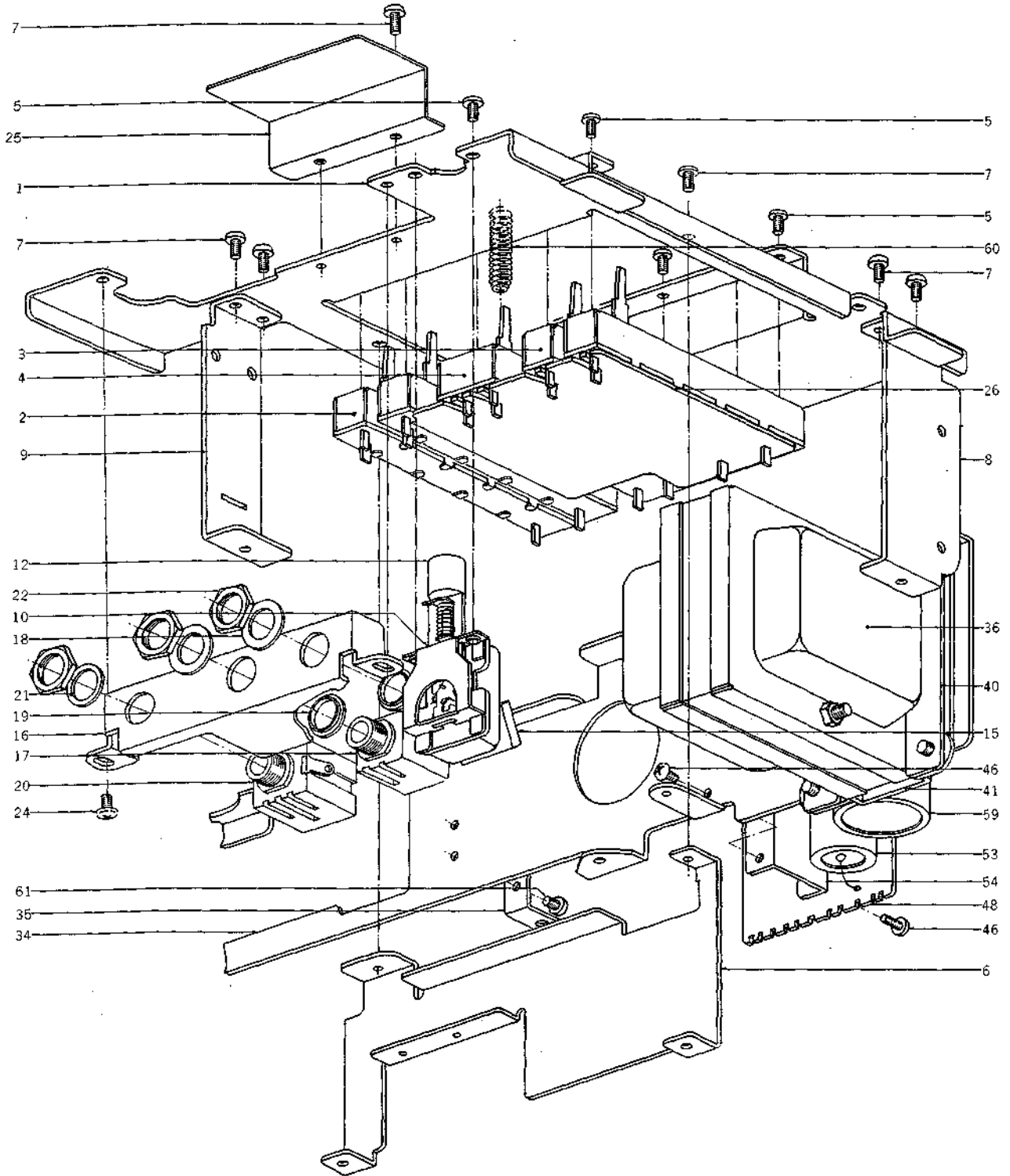

AMP. CHASSIS & POWER SUPPLY BRACKET BLOCK

Ref. No.	Parts No.	Description	Schematic No.	Q'ty
AMP. CHASSIS BLOCK				
6-1	UM518501	Amp. Chassis C	CT-5035	1
6-2	EV494436	Slide Volume LD14A003-10		
		KA	36-16-6	2
6-3	EV453396	Slide Volume LD14A 50 kA		
		L=20M/M	36-16-3	2
6-4	EV453420	Slide Volume MD14A003		
		100 kBX2	36-27-1	1
6-5	ZW371856	ISO Screw, binding head 3x5		12
6-6	UM518027	Heat-sink Plate A	CG-5405	1
6-7	ZW447772	Tapping Screw #2 3x6(BR)		8
6-8	UM484042	Retaining Foot A	CT-1001	1
6-9	UM483930	P.C. Board Retaining Plate	CT-1004	1
6-10	ES469541	Push Switch JB-52 (Power)	25-5-60	1
6-11x	ES499972	Push Switch JS-09 (Power)	(WG) 25-5-67	1
6-12	SK543172	Operation Knob	CG-2402	1
6-13x	SK495202	Power Supply Knob (WG)	CG-6308	1
6-14x	SK371621	PTA Knob (black)	ED-615	1
6-15	ER376413	Spark Quencher U/L		
		0.033μ+120 500WV	41-1-37	1
6-16	UM518038	Jack Bracket D	CG-5409	1
6-17	EJ315281	Mic. Jack 2PMJ1	31-2-19	2
6-18	ZW437084	Washer (Fiber)D9.1x15.4x0.5t		2
6-19	EZ469721	Nylon Collar, Jack B	2-4-27	2
6-20	EJ376604	Mic. Jack 3PMJ1	31-2-17	1
6-21	ZW376481	Jack Thin Washer		
		D9.1x11.7x0.25t	DX-509	1
6-22	ZW270191	E Jack Nut		3
6-23x	ER214290	Carbon/R. RD1/4 4.7k(f)		
		(Insu. type)	35-9-5	2
6-24	ZW323728	Screw, binding head 3x5		2
6-25	UM496596	Mic. Jack Shield	CG-5308	1
6-26	EA498857	Tone Control P.C. Board	CG-5207	1
6-27x	ER324685	Carbon/R. RD1/4 33k(J)		
		(Insu. type)	35-9-5	2
6-28x	ER213647	Carbon/R. RD1/4 10k(J)		
		(Insu. type)	35-9-5	2
6-29x	EC362125	Mylar 0.0056μF(K)		
		(Vert. type)	24-1-1	2
6-30x	EM517296	VU Meter KL-243G-14(blue)	46-1-66	2
6-31x	EM561745	VU Meter KL-243G-17(black)	46-1-60	2
6-32x	UM530302	Trans. Support (UL, J)	CG-5703	1
6-33x	ZW447840	Tapping Screw #2 3x8(BR)		
		(UL, J)		4

POWER SUPPLY BRACKET BLOCK

6-34	UM518850	Power Supply Bracket D	CG-5408	1
6-35	UM494458	P.C. Board Bracket 1	CG-1201	2
6-36	BT517432	Power Trans. CGT-22	38-4-208	1
6-37x	BT517241	Power Trans. CGT-23 (UL, J)	38-4-217	1
6-38x	BT517195	Power Trans. CGT-20 (44D)	38-4-207	1
6-39x	BT517230	Power Trans. CGT-19 (44D-J)	38-4-215	1
6-40	UM470452	Trans. Retaining Plate	CG-5028	2
6-41	UM483985	Trans. Table	CT-5036	1
6-42x	ZW468112	Tapping Screw #2 4x8(truss)		4
6-43x	ZW273914	Spring Washer M4		3
6-44x	ZW419736	Screw, binding head 4x6		3
6-45x	UM516598	Trans. Retainer (UL)	CS-5337	2
6-46	ZW447772	Tapping Screw #2 3x6(BR)		6
6-47x	EZ486617	Trans. Reinforcement Plate B		
		(44D)	LF-5222	2
6-48	EA514811	Fuse P.C. Board J	CG-1306J	1
6-49x	EA514800	Fuse P.C. Board (UL)	CG-1306U	1
6-50x	EJ514822	Fuse Holder P.C. Board (UL)	40-1-28	2
6-51x	EF371698	Fuse ST-4 0.5A (UL)	39-1-28	1
6-52x	EF480892	Fuse 0.8A 125V (44D-J)	39-1-44	1
6-53	EC514754	MP/C. 1μ250WVAC(Tub. type)	24 9-68	1
6-54	UM514833	Fuse P.C. Board Table	CG-1307	1
6-55x	EJ345857	Lug Plate KP2L1 (44D-J)	33-3-14	1
6-56x	ZW447772	Tapping Screw #2 3x6(BR)		
		(44D-J)		1

Ref. No.	Parts No.	Description	Schematic No.	Q'ty
6-57x	EZ486797	Power Supply Cord VDE (WG)	26-3-26	1
6-58x	EJ254970	Lug Plate KP1L1 (WG)	33-3-3	1
6-59	EC453431	Elect. 2200μF 35WV		
		(Lug type)	24-10-70	1
6-60	ZG512144	Earth Spring B	CG-5317	1
6-61	ZW447772	Tapping Screw #2 3x6(BR)		4

When ordering parts, please describe Parts Number, Serial Number, and Model Number in detail.

FIG. 7 ILLUSTRATION OF VU CHASSIS & REAR CHASSIS BLOCK

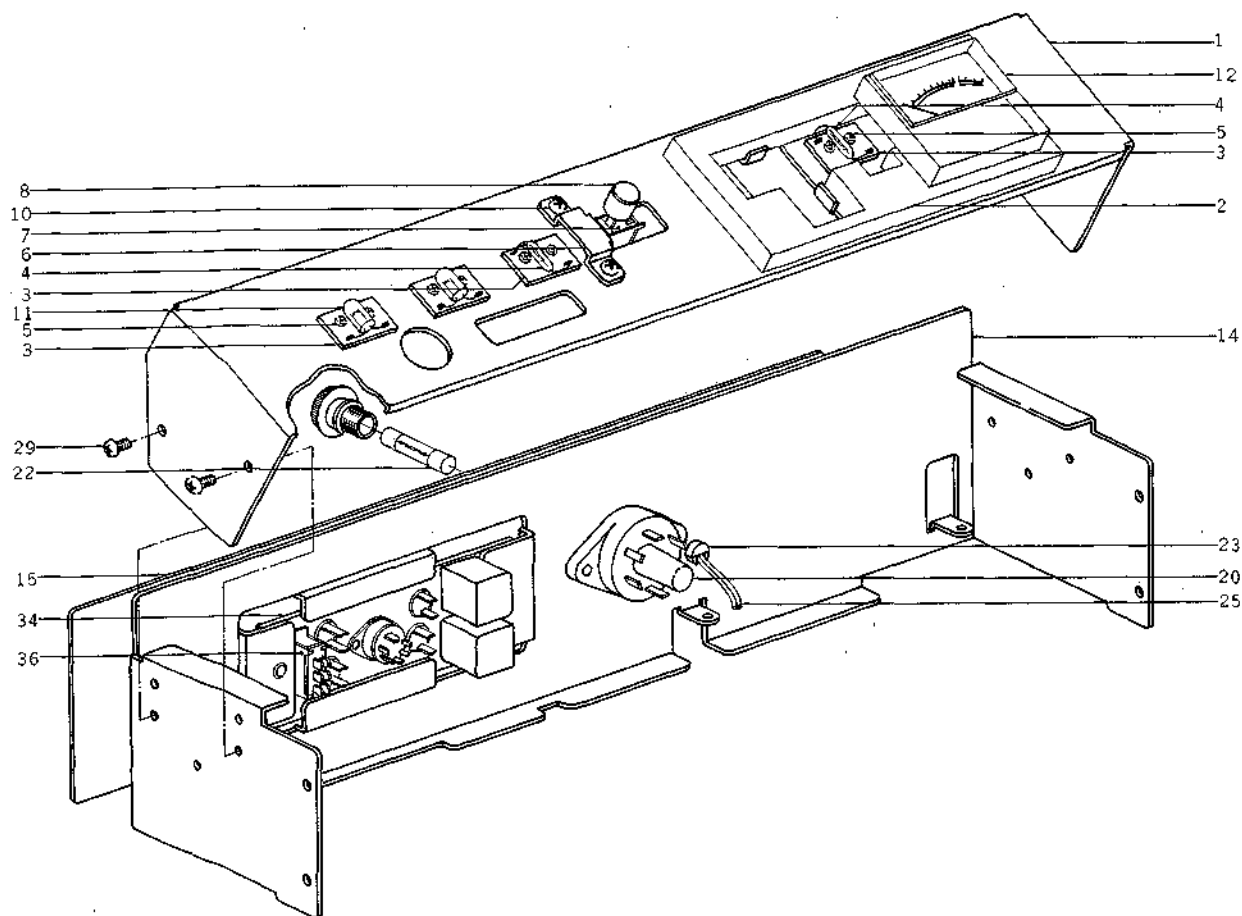

VU CHASSIS & REAR CHASSIS BLOCK

Ref. No.	Parts No.	Description	Schematic No.	Q'ty	Ref. No.	Parts No.	Description	Schematic No.	Q'ty
VU CHASSIS BLOCK					7-22	EF277402	Fuse ST-2 1A	39-1-26	1
7-1	UM518758	VU Chassis L	CG-2501	1	7-23	EZ382263	Strain Relief SR-4K-4	2-7-12	1
7-2	UM494537	VU Mat	CG-2205	1	7-24x	EZ246936	Strain Relief SR-6W-1 (WG, 3 core)	2-7-8	1
7-3	EZ457176	Lamp P.C. Board	CG-5003	4	7-25	EW540112	AC Cord (CUL)2.5M	26-3-19	1
7-4	EL295312	No. 2 Lamp 8V 0.2A	28-2-8	2	7-26x	EZ315448	Australia Cord (3 core)	26-3-11	1
7-5	ZW517318	Tapping Screw #2 2.3x5(BR)		8	7-27x	EW524845	AC Cord (JAPAN)2.5M	26-3-31	1
7-6	UM518837	Push Switch Table	CG-2502	1	7-28x	EJ345857	Lug Plate KP2L1 (44D-J)	33-3-14	1
7-7	ES494594	Push Switch UEG42A	25-5-70	1	7-29	ZW447772	Tapping Screw #2 3x6(BR)		6
7-8	SK487675	Knob C, w/bush	CG-2007	1	7-30x	ZW273881	Earth Lug M4		1
7-9x	ZW517083	Screw, round head 2.6x3		2	7-31x	ZW413223	Screw, binding head 3x5, w/washer		1
7-10	ZW447772	Tapping Screw #2 3x6(BR)		2	7-32x	BZ519096	Jack Plate Block Comp.	CG-4,5,7	1
7-11	EL390576	Pilot Lamp RM6-24V-50MA (Lead type)	28-2-6	2	7-33x	BZ519107	Jack Plate Block Comp. (44D)	CG-4,5,6,7	1
7-12	EM517296	VU Meter KL-243G-14(blue)	46-1-66	2	7-34	EJ518872	Jack Plate I	CG-6415	1
7-13x	EM561745	VU Meter KL-243G-17(black)	46-1-30	2	7-35x	EJ518883	Jack Plate J	CG-6415	1
REAR CHASSIS BLOCK					7-36	ES379045	6P Slide Switch SJ-0282	25-3-36	1
7-14	UM518861	Rear Chassis C	CG-2503	1	7-37x	ER440921	Carbon/R. RD1/4 27k(J) (Insu. type)	35-9-5	2
7-15	SM518760	Name Plate, Jack G	CG-6507	1	7-38x	ER529975	Carbon/R. RD1/4 430k(J) (Insu. type)	35-9-5	2
7-16x	SM530561	Name Plate, Jack L (UL)	CG-6507	1	7-39x	ER315213	Carbon/R. RD1/4 8.2k(J) (Insu. type)	35-9-5	2
7-17x	SM518793	Name Plate, Jack J (J)	CG-6507	1	7-40x	ER345712	Carbon/R. RD1/4 22k(J) (Insu. type)	35-9-5	2
7-18x	SM518771	Name Plate, Jack H (44D)	CG-6507	1					
7-19x	SM518804	Name Plate, Jack K (44D-J)	CG-6507	1					
7-20	EJ233370	Power Plug Socket S-18010	40-2-8	1					
7-21x	ZW481724	ISO Screw, truss head 3x6		2					

When ordering parts, please describe Parts Number, Serial Number, and Model Number in detail.

**FIG. 8 PHOTO OF DOLBY
P.C. BOARD (CG-5202)**

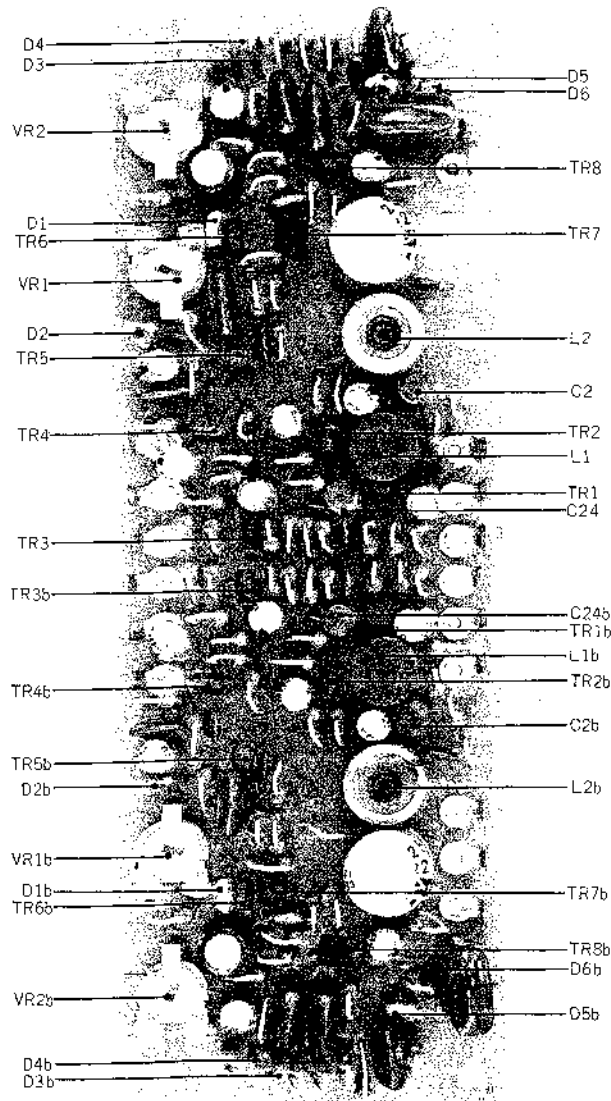

DOLBY P.C. BOARD (CG-5202) BLOCK

Symbol No.	Parts No.	Description	Q'ty
8-1x	BA498767	Dolby P.C. Board Comp.(CG-5202)	1
8-TR1	ET234854	Transistor 2SC458LG(C)	2
8-TR2	ET329218	Transistor 2SC458(C)	2
8-TR3	ET352146	Transistor 2SC458LG(D)	2
8-TR4	ET329218	Transistor 2SC458(C)	2
8-TR5	ET491051	FET 2SK30A(GR)	2
8-TR6	ET234854	Transistor 2SC458LG(C)	2
8-TR7	ET350335	Transistor 2SA564(Q)	2
8-TR8	ET329218	Transistor 2SC458(C)	2
8-D1	ED219464	Germanium Diode 1N34A	2
8-D2	ED491130	Zener Diode WZ085	2
8-D3, 4	ED514721	Silicon Diode WG-599	4
8-D5	ED219464	Germanium Diode 1N34A	2

Symbol No.	Parts No.	Description	Q'ty
8-D6	ED514721	Silicon Diode WG-599	2
8-VR1	EV499364	Semi-fixed Volume V10K8-4-2	2
		5 kB	2
8-VR2	EV499375	Semi-fixed Volume V10K8-4-2	2
		500 B	2
8-L1	EO496350	Inductor 146LY 36MH(J)	2
8-L2	EO496361	Inductor 6070GE 23MH(J)	2
8-2x	EJ350447	Test Terminal	2
Capacitor, Vertical Type			
8-C1	EC320051	Elect. 10µF 16WV	2
8-C2	EC495865	Styrol 3000PF(J) 50WV	2
8-C3	EC379787	Mylar 0.0039µF(J) 50WV	2
8-C4	EC320051	Elect. 10µF 16WV	2
8-C5	EC250683	Mylar 0.0022µF(J) 50WV	2
8-C6, 7, 8	EC320051	Elect. 10µF 16WV	6
8-C9, 10	EC313121	Elect. 220µF 25WV	4
8-C11	EC329883	Mylar 0.0056µF(J) 50WV	2
8-C12	EC337500	Mylar 0.0047µF(J) 50WV	2
8-C13	EC329861	Mylar 0.027µF(J) 50WV	2
8-C14	EC320051	Elect. 10µF 16WV	2
8-C15	EC251291	Mylar 0.1µF(K) 50WV	2
8-C16	EC320040	Elect. 47µF 16WV	2
8-C17	EC320051	Elect. 10µF 16WV	2
8-C18	EC251291	Mylar 0.1µF(K) 50WV	2
8-C19	EC320051	Elect. 10µF 16WV	2
8-C20	EC379170	Mylar 0.1µF(J) 50WV	2
8-C21	EC251291	Mylar 0.1µF(K) 50WV	2
8-C22	EC395504	Mylar 0.33µF(K) 50WV	2
8-C23	EC290520	VFM 100PF(J) 50WV	2
8-C24	EC434070	Styrol 680PF(J) 50WV	2
Resistor, Stopper Type			
8-R1	ER336442	Carbon RD1/4 10k(J)	2
8-R2	ER212477	Carbon RD1/4 3.3k(J)	2
8-R3	ER426857	Carbon RD1/4 270k(J)	2
8-R4	ER346601	Carbon RD1/4 47k(J)	2
8-R5	ER212477	Carbon RD1/4 3.3k(J)	2
8-R6	ER304402	Carbon RD1/4 470(J)	2
8-R7	ER211858	Carbon RD1/4 12k(J)	2
8-R8	ER211667	Carbon RD1/4 100(J)	2
8-R9	ER211858	Carbon RD1/4 12k(J)	2
8-R10	ER343078	Carbon RD1/4 2.7k(J)	2
8-R11	ER349907	Carbon RD1/4 33k(J)	2
8-R12	ER357570	Carbon RD1/4 150k(J)	2
8-R13	ER212174	Carbon RD1/4 180k(J)	2
8-R14, 15	ER212264	Carbon RD1/4 22k(J)	4
8-R16	ER357570	Carbon RD1/4 150k(J)	2
8-R17	ER349942	Carbon RD1/4 8.2k(J)	2
8-R18	ER343078	Carbon RD1/4 2.7k(J)	2
8-R19	ER349907	Carbon RD1/4 33k(J)	2
8-R20, 21	ER213467	Carbon RD1/4 820(J)	4
8-R22	ER349907	Carbon RD1/4 33k(J)	2
8-R23	ER357535	Carbon RD1/4 39k(J)	2
8-R24	ER212477	Carbon RD1/4 3.3k(J)	2
8-R25	ER357456	Carbon RD1/4 2.2k(J)	2
8-R26	ER349942	Carbon RD1/4 8.2k(J)	2
8-R27	ER306843	Carbon RD1/4 1.2k(J)	2
8-R28	ER430097	Carbon RD1/4 680k(J)	2
8-R29	ER306887	Carbon RD1/4 15k(J)	2
8-R30	ER349942	Carbon RD1/4 8.2k(J)	2
8-R31	ER336442	Carbon RD1/4 10k(J)	2
8-R32, 33	ER349942	Carbon RD1/4 8.2k(J)	4
8-R34	ER349907	Carbon RD1/4 33k(J)	2
8-R35	ER450011	Carbon RD1/4 120k(J)	2
8-R36	ER346601	Carbon RD1/4 47k(J)	2
8-R37	ER343078	Carbon RD1/4 2.7k(J)	2
8-R38	ER211465	Carbon RD1/4 1k(J)	2
8-R39	ER380913	Carbon RD1/4 33(J)	2
8-R40	ER361642	Carbon RD1/4 47(J)	2
8-R41	ER306887	Carbon RD1/4 15k(J)	2
8-R42, 43	ER426857	Carbon RD1/4 270k(J)	4
8-R44	ER380711	Carbon RD1/4 220k(J)	2
8-R45	ER212883	Carbon RD1/4 4.7k(J)	2

When ordering parts, please describe Parts Number, Serial Number, and Model Number in detail.

Dolby is a trademark of Dolby Laboratories, Inc. Under License from Dolby Laboratories, Inc.

FIG. 9 PHOTO OF MAIN AMP. P.C. BOARD (CG-5009)

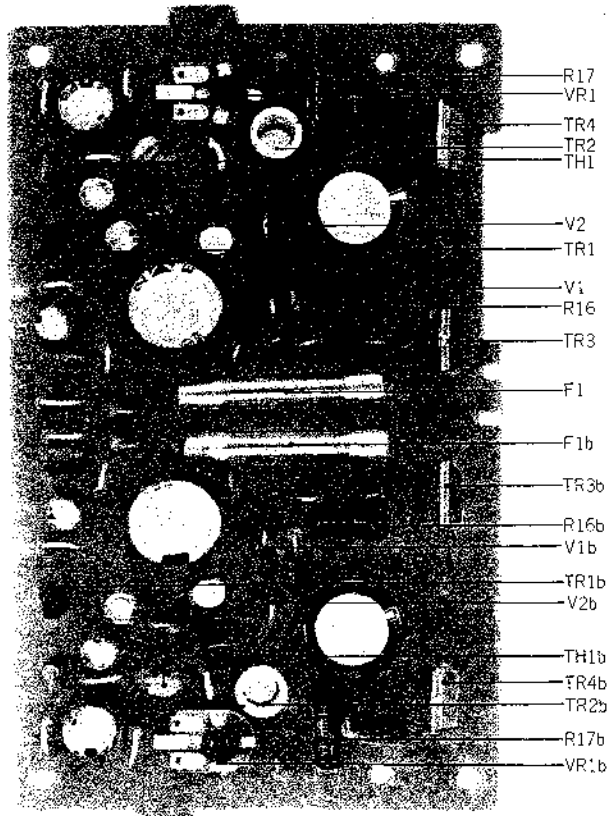

MAIN AMP. P.C. BOARD (CG-5009) BLOCK

Symbol No.	Parts No.	Description	Q'ty
9-1x	BA524946	Main Amp. P.C. Board Comp. (CG-5009)	1
9-TR1	ET539987	Transistor 2SC1312(F) (G)	2
9-TR2	ET304255	Transistor 2SC971(2) (3) red	2
9-TR3	ET465208	Transistor 2SC1098(L) (K)	2
9-TR4	ET465265	Transistor 2SA636(L) (K)	2
9-TH1	ED453655	Thermister 42D26	2
9-V1, 2	ED453644	Varistor RV	4
9-VR1	EV329152	Semi-fixed Volume V10K5-2-4 30 kB	2
9-F1	EF453666	Fuse ST-3 0.7A	2
9-2x	ZW461452	Insulator Washer	2
9-3x	ZW323728	Screw, binding head 3x5	4
9-4	ZW461452	Insulator Washer	2
9-5	EZ452992	Heat-sink Plate	1
9-6	ZW417227	Screw, binding head 2.3x5	2
Capacitor, Vertical Type			
9-C1	EC350706	Elect. 4.7 μ F 16WV	2
9-C2	EC290531	VFM 100PF(K) 50WV	2
9-C3	EC372148	Elect. 220 μ F 35WV	2
9-C4	EC320051	Elect. 10 μ F 16WV	2
9-C5	EC331828	Elect. 3.3 μ F 25WV	2
9-C6	EC220364	Elect. 100 μ F 6.3WV	2
9-C7	EC331705	Elect. 22 μ F 16WV	2
9-C8	EC250604	Mylar 0.001 μ F(K) 50WV	2
9-C9	EC331817	Elect. 470 μ F 25WV	2
9-C10	EC308711	Mylar 0.047 μ F(K) 50WV	2
Resistor, Stopper Type			
9-R1, 2	ER211757	Carbon RD1/4 100k(J)	4
9-R3	ER212477	Carbon RD1/4 3.3k(J)	2
9-R4	ER211465	Carbon RD1/4 1k(J)	2
9-R5	ER211667	Carbon RD1/4 100(J)	2
9-R6	ER211465	Carbon RD1/4 1k(J)	2
9-R7	ER349942	Carbon RD1/4 8.2k(J)	2
9-R8	ER352045	Carbon RD1/4 3.9k(J)	2
9-R9	ER349784	Carbon RD1/4 390(J)	2
9-R10	ER357535	Carbon RD1/4 39k(J)	2
9-R11	ER306360	Carbon RD1/4 6.8k(J)	2
9-R12	ER349784	Carbon RD1/4 390(J)	2
9-R13	ER304290	Carbon RD1/4 10(J)	2
9-R14	ER361642	Carbon RD1/4 47(J)	2
9-R15	ER347038	Carbon RD1/4 270(J)	2
9-R16, 17	ER557302	Metal Oxide Film MPC70 2 0.5(J)	4
9-R18	ER399723	Carbon RD1/4 4.7(J)	2

When ordering parts, please describe Parts Number, Serial Number, and Model Number in detail.

FIG. 10 PHOTO OF MAIN AMP. P.C. BOARD (CG-5403) (GXC-38 UL, J)

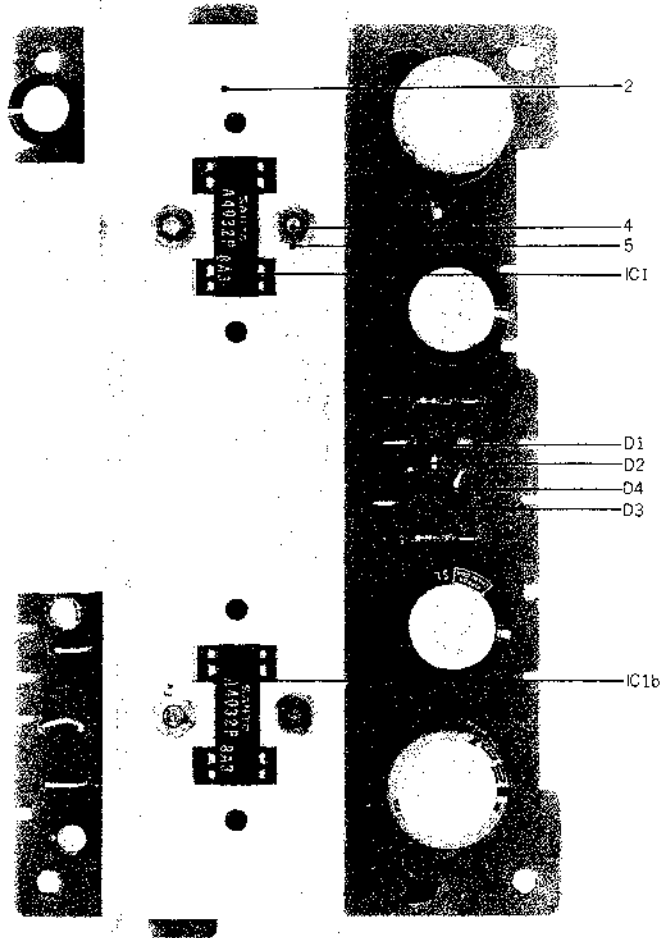

**MAIN AMP. P.C. BOARD (CG-5403) BLOCK
(GXC-38 UL, J)**

Symbol No.	Parts No.	Description	Qty
10-1x	BA519568	Main Amp. P.C. Board Comp. (CG-5403)(UL, J)	1
10-IC1	EI517342	Power Amp. I.C. LA-4032P	2
10-D1	ED511097	Silicon Diode IN4001	1
10-D2, 3, 4	ED511097	Silicon Diode IN4001	3
10-2	UM518657	Heat-sink	1
10-3x	UM518668	I.C. Retaining Metal	1
10-4	ZW417194	Screw, binding head 3x10	4
10-5	ZW273756	Nut M3	4
Capacitor, Vertical Type			
10-C1	EC320051	Elect. 10 μ F 16WV	2
10-C2	EC450066	Elect. 33 μ F 16WV	2
10-C3	EC321208	Elect. 220 μ F 16WV	2
10-C4	EC250661	Mylar 0.0015 μ F(K) 50WV	2
10-C5	EC362158	Mylar 0.0047 μ F(K) 50WV	2
10-C6	EC394020	Hi-Q 560PF(K) 50WV	2
10-C7	EC450270	Elect. 1000 μ F 25WV	2
10-C8	EC336148	Elect. 1000 μ F 16WV	2
10-C9	EC250885	Mylar 0.01 μ F(K) 50WV	2
Resistor, Stopper Type			
10-R1	ER212681	Carbon RD1/4 330(J)	2
10-R2	ER517320	Carbon RD1/4 0.5(J)(Insu. type)	2
10-R3	ER336442	Carbon RD1/4 10k(J)	2
10-R4	ER306887	Carbon RD1/4 15k(J)	2

When ordering parts, please describe Parts Number, Serial Number, and Model Number in detail.

FIG. 11 PHOTO OF PRE AMP. P.C. BOARD (CG-5402)

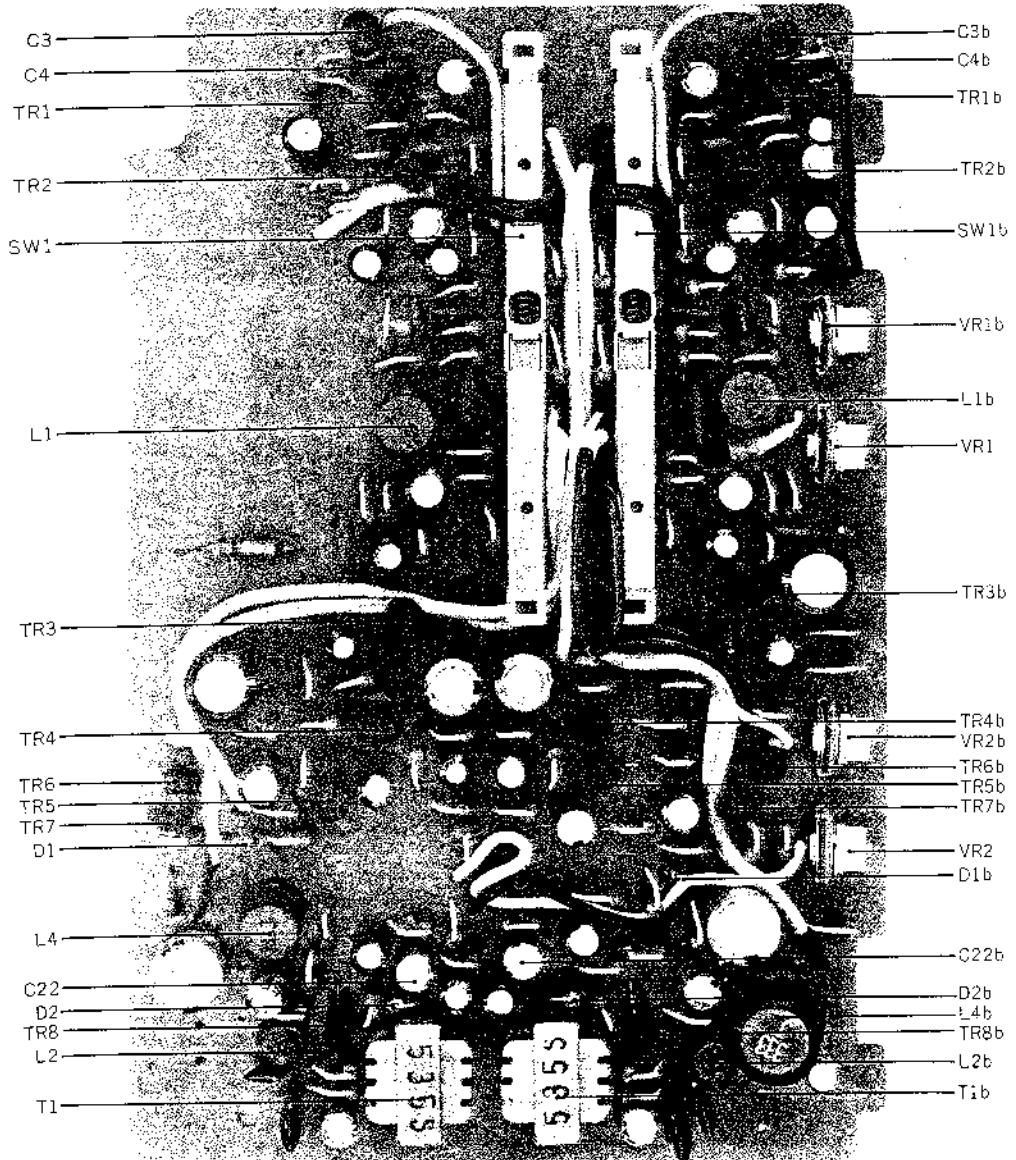

PRE AMP. P.C. BOARD (CG-5402) BLOCK

Symbol No.	Parts No.	Description	Q'ty	Symbol No.	Parts No.	Description	Q'ty
11-1x	BA517882	Pre Amp. P.C. Board Comp. (CG-5402)	1	11-R24	ER211320	Carbon RD1/4 1.5k(J)	2
11-TR1, 2, 3	ETS17263	Transistor 2SC1312(G) (H)	6	11-R25	ER211757	Carbon RD1/4 100k(J)	2
11-TR4 to 8	ET398777	Transistor 2SC711(G) (F)	10	11-R26	ER357412	Carbon RD1/4 220(J)	2
11-D1	ED516420	Silicon Diode WG-599	2	11-R27	ER306887	Carbon RD1/4 15k(J)	2
11-D2	ED219464	Germanium Diode 1N34A	2	11-R28	ER211465	Carbon RD1/4 1k(J)	2
11-L1	EO368403	Ferri Inductor FL9H 33MH(J)	2	11-R29	ER211757	Carbon RD1/4 100k(J)	2
11-L2	EO243988	Ferri Inductor FL7H 3.3MH(J)	2	11-R30	ER346544	Carbon RD1/4 3k(J)	2
11-L4	EO368403	Ferri Inductor FL9H 33MH(J) (Left ch.)	1	11-R31	ER350065	Carbon RD1/4 430(J)	2
11-L4b	EOS50552	Inductor FS1215S 33μH(J) (Right ch.)	1	11-R32	ER420322	Carbon RD1/4 36k(J)	2
11-VR1	EV554670	Semi-fixed Volume V10K8-1-5 1 kB	2	11-R33	ER211667	Carbon RD1/4 100(J)	2
11-VR2	EV554668	Semi-fixed Volume V10K8-1-5 20 kB	2	11-R34	ER212883	Carbon RD1/4 4.7k(J)	2
11-T1	ETS17274	Head Phone Trans. N16-535S	2	11-R35	ER211757	Carbon RD1/4 100k(J)	2
11-SW1	ES494076	Slide Switch CL109B	2	11-R36	ER430018	Carbon RD1/4 1(J)	2
		Capacitor, Vertical Type		11-R37	ER357491	Carbon RD1/4 82k(J)	2
11-C1	EC220127	Elect. 100μF 16WV	2	11-R38	ER362441	Carbon RD1/4 1.8k(J)	2
11-C2	EC320051	Elect. 10μF 16WV	2	11-R39	ER211757	Carbon RD1/4 100k(J)	2
11-C3	EC435690	Styrol 560PF(J) 50WV	2	11-R40	ER306887	Carbon RD1/4 15k(J)	2
11-C4	EC405898	Styrol 470PF(J) 50WV	2	11-R41	ER347073	Carbon RD1/4 200(J)	2
11-C5	EC399565	VFM 22PF(J) 50WV	2	11-R42	ER213300	Carbon RD1/4 680(J)	2
11-C6	EC329771	Elect. 47μF 6.3WV	2	11-R43	ER304290	Carbon RD1/4 10(J)	2
11-C7	EC320051	Elect. 10μF 16WV	2	11-R44, 45	ER430018	Carbon RD1/4 1(J)	4
11-C8	EC220432	Elect. 2.2μF 25WV	2	11-R46	ER342933	Carbon RD1/4 27k(J)	2
11-C9	EC320051	Elect. 10μF 16WV	2				
11-C10	EC389485	Mylar 0.018μF(J) 50WV	2				
11-C11	EC379765	Mylar 0.0027μF(J) 50WV	2				
11-C13	EC320051	Elect. 10μF 16WV	2				
11-C14	EC389237	VFM 200PF(J) 50WV	2				
11-C15	EC329771	Elect. 47μF 6.3WV	2				
11-C16	EC220364	Elect. 100μF 6.3WV	2				
11-C17	EC524957	VFM 39PF(K) 50WV	2				
11-C18	EC389237	VFM 200PF(J) 50WV	2				
11-C19	EC320051	Elect. 10μF 16WV	2				
11-C20	EC336126	Elect. 47μF 25WV	2				
11-C21	EC320051	Elect. 10μF 16WV	2				
11-C22	EC487157	NP 0.47μF 50WV	2				
11-C23	EC329771	Elect. 47μF 6.3WV	2				
11-C24	EC450527	Elect. 4.7μF 25WV	2				
11-C25	EC379157	Mylar 0.033μF(J) 50WV	2				
11-C26	EC320051	Elect. 10μF 16WV	2				
11-C27	EC329883	Mylar 0.0056μF(J) 50WV	2				
11-C28, 29	EC389237	VFM 200PF(J) 50WV	2				
11-C31	EC450055	Elect. 1μF 25WV	2				
11-C32, 33	EC320051	Elect. 10μF 16WV	4				
		Resistor, Stopper Type					
11-R1	ER212883	Carbon RD1/4 4.7k(J)	2				
11-R2	ER380755	Carbon RD1/4 6.2k(J)	2				
11-R3	ER465276	Carbon RD1/4 270k(J)NL	2				
11-R4	ER336442	Carbon RD1/4 10k(J)	2				
11-R5	ER306843	Carbon RD1/4 1.2k(J)	2				
11-R6	ER212264	Carbon RD1/4 22k(J)	2				
11-R7	ER212883	Carbon RD1/4 4.7k(J)	2				
11-R8	ER357570	Carbon RD1/4 150k(J)	2				
11-R9	ER343078	Carbon RD1/4 2.7k(J)	2				
11-R10	ER336442	Carbon RD1/4 10k(J)	2				
11-R11	ER450011	Carbon RD1/4 120k(J)	2				
11-R12	ER212883	Carbon RD1/4 4.7k(J)	2				
11-R13	ER213647	Carbon RD1/4 10k(J) (Left ch.)	1				
11-R13b	ER336442	Carbon RD1/4 10k(J) (Right ch.)	1				
11-R14	ER212264	Carbon RD1/4 22k(J)	2				
11-R15	ER212883	Carbon RD1/4 4.7k(J)	2				
11-R16	ER379473	Carbon RD1/4 30k(J)	2				
11-R17	ER342933	Carbon RD1/4 27k(J)	2				
11-R18	ER213030	Carbon RD1/4 5.6k(J)	2				
11-R19	ER212681	Carbon RD1/4 330(J)	2				
11-R20	ER213030	Carbon RD1/4 5.6k(J)	2				
11-R21	ER212883	Carbon RD1/4 4.7k(J)	2				
11-R22	ER343078	Carbon RD1/4 2.7k(J)	2				
11-R23	ER306360	Carbon RD1/4 6.8k(J)	2				

When ordering parts, please describe Parts Number, Serial Number, and Model Number in detail.

FIG. 12 PHOTO OF SYSTEM CONTROL P.C. BOARD (CG-1413)

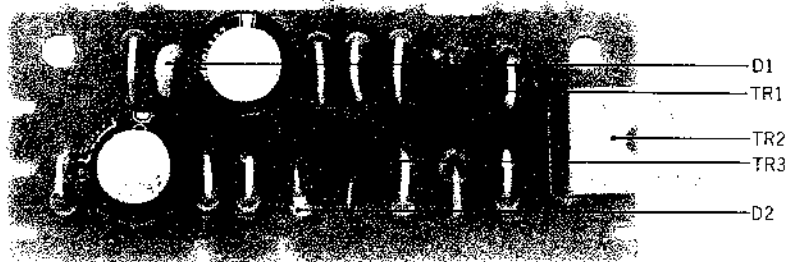

**SYSTEM CONTROL
P.C. BOARD (CG-1413) BLOCK**

Symbol No.	Parts No.	Description	Q'ty
12-1x	BA519131	System Control P.C. Board Comp. (CG-1413)	1
12-2x	BA557335	System Control P.C. Board Comp. (CG-1413) (44D-1)	1
12-TR1	ET398777	Transistor 2SC711(G) (F)	1
12-TR2	ET517375	Transistor 2SD360(D) (E)	1
12-TR3	ET539122	Transistor 2SA733(P) (Q) (R)	1
12-D1	ED515790	Silicon Diode WG-713	1
12-D2	ED516420	Silicon Diode WG-599	1
12-C1, 2	EC220151	Elect. Capacitor 100 μ F 25WV	2
Resistor, Stopper Type			
12-R1, 2	ER212883	Carbon RD1/4 4.7k(J)	2
12-R3, 5	ER211465	Carbon RD1/4 1k(J)	2
12-R6	ER212264	Carbon RD1/4 22k(J)	1
12-R7	ER346994	Carbon RD1/4 18k(J)	1
12-R8	ER357456	Carbon RD1/4 2.2k(J) (44D-J)	1
12-R9	ER550811	Carbon RD1/2 1.5k(J) (Insu. type)	1
12-R10	ER430018	Carbon RD1/4 1(J)	1
12-R11	ER357456	Carbon RD1/4 2.2k(J) (44D-J)	1
12-R12	ER212264	Carbon RD1/4 22k(J)	1

FIG. 13 PHOTO OF POWER SUPPLY P.C. BOARD (CG-5401)

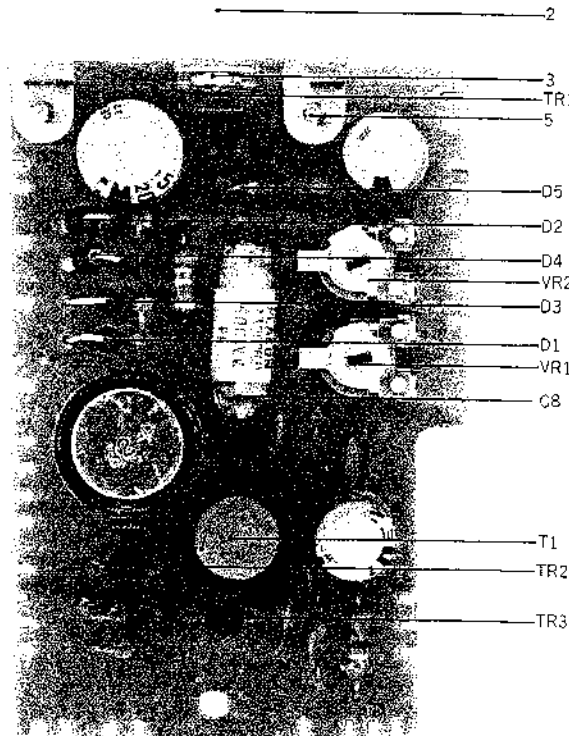

**POWER SUPPLY
P.C. BOARD (CG-5401) BLOCK**

Symbol No.	Parts No.	Description	Q'ty	Symbol No.	Parts No.	Description	Q'ty
13-1x	BA554703	Power Supply P.C. Board Comp. (CG-5401)	1	13-C5	EC250841	Mylar 0.01 μ F(J) 50WV	1
13-TR1	ET453611	Transistor 2SC1096(L) (K) (Z type)	1	13-C6	EC220151	Elect. 100 μ F 25WV	1
13-TR2, 3	ET517994	Transistor 2SC945(P) (Q) (R) (K)	2	13-C7	EC250841	Mylar 0.01 μ F(J) 50WV	1
13-D1 to 4	ED511097	Silicon Diode IN4001	4	13-C8	EC554613	Styrol 3600PF(J) 250WV (Tub. type)	1
13-D5	ED498150	Zener Diode WZ-192	1	13-C9, 10	EC290520	VFM 100PF(J) 50WV	2
13-T1	EO496844	OSC. Coil OT-903	1			Resistor, Stopper Type	
13-VR1, 2	EV499882	Semi-fixed Volume V10K8-4-2 300 k Ω	2	13-R1	ER215234	Carbon RD1/2P 4.7(K) (Insu. type)	1
13-2	UM518646	Heat-sink Plate B	1	13-R2	ER211465	Carbon RD1/4 1k(J)	1
13-3	ZW413741	Screw, binding head 3x8	1	13-R3	ER361642	Carbon RD1/4 47(J)	1
13-4x	ZW273756	Nut M3	1	13-R4	ER430053	Carbon RD1/4 22(J)	1
13-5	ZW413728	Screw, binding head 3x6, w/washer	2	13-R5	ER411726	Carbon RD1/2 220(K) (Insu. type)	1
		Capacitor, Vertical Type		13-R6	ER304290	Carbon RD1/4 10(J)	1
13-C1	EC432652	Elect. 1000 μ F 35WV	1	13-R7	ER212883	Carbon RD1/4 4.7k(J)	1
13-C3, 4	EC220151	Elect. 100 μ F 25WV	2	13-R8	ER304290	Carbon RD1/4 10(J)	1
				13-R9	ER212681	Carbon RD1/4 330(J)	1

When ordering parts, please describe Parts Number, Serial Number, and Model Number in detail.

FIG. 14 PHOTO OF FINAL ASSEMBLY BLOCK

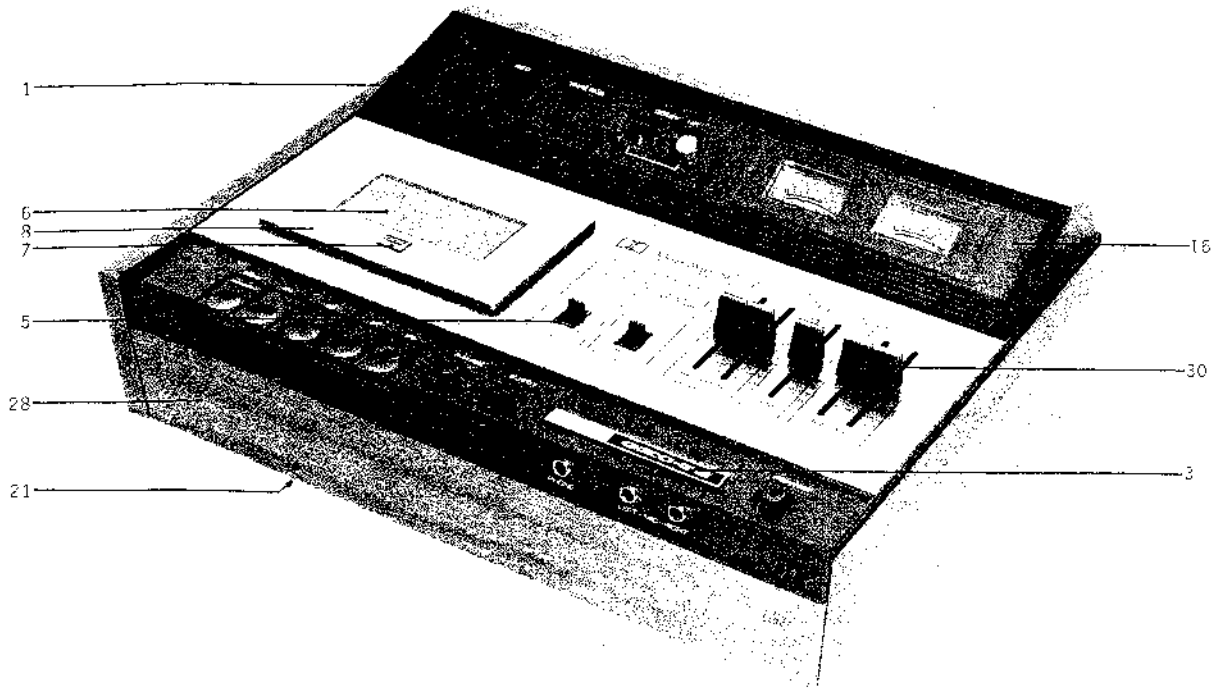
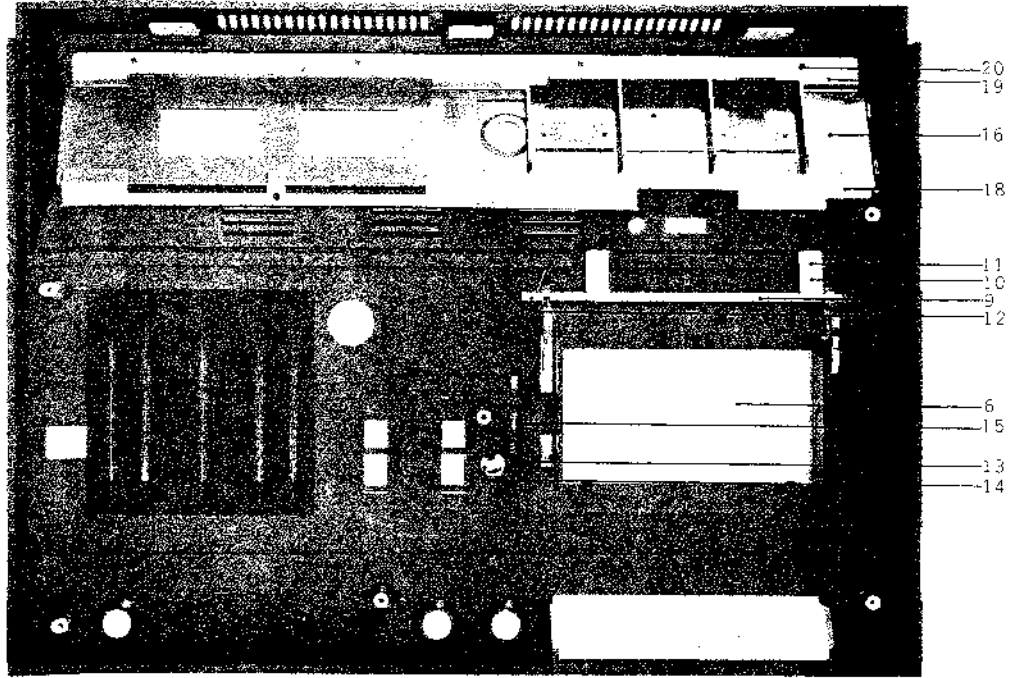

FINAL ASSEMBLY BLOCK

Ref. No.	Parts No.	Description	Schematic No.	Q'ty
UPPER CASE BLOCK				
14-1	BC564344	Upper Case Block Comp.	CG-5	1
14-2x	BC564355	Upper Case Block Comp.	(44D) CG-5	1
14-3	SM518185	Name Plate GXC-38	CG-6404	1
14-4x	SM531516	Name Plate GXC-44D	CG-6701	1
14-5	SE530267	Switch Escutcheon B	CT-6017	2
14-6	UM518297	Case Lid B	CG-6409	1
14-7	SM518310	GX Name Plate B	CG-6411	1
14-8	UM518308	Lid Cover	CG-6410	1
14-9	MS495134	Cassette Holder Shaft	CG-6305	1
14-10	UM495145	Shaft Retainer	CG-6306	2
14-11	ZW323728	Screw, binding head 3x5		2
14-12	ZG453115	Lid Spring	CG-6013	1
14-13	UM453060	Hook Lever (2)	CG-6007	1
14-14	ZW290283	'U' Ring 2.85M	6-1-1	1
14-15	ZG469372	Lid Spring B	CG-6053	1
14-16	SP518376	Meter Panel A, w/indicator	CG-6503	1
14-17x	SP531505	Panel Cover (44D)	CG-6514	1
14-18	UM518400	Case Angle C	CG-6505	1
14-19	UM518411	Case Angle D	CG-6506	1
14-20	ZW417137	Screw, binding head 3x4		7
LOWER CASE BLOCK				
14-21	BC564006	Lower Case Block Comp.	CG-5	1
14-22x	BC564388	Lower Case Block Comp.	(UL) CG-5	1
14-23x	UM453262	Cover (Cycle Change)	CG-6021	1
14-24x	UM483412	Cover (Cycle Change) (UL)	CG-6057	1
14-25x	SP494122	Bottom Cover	CG-6208	1
14-26x	SZ484121	Rubber Foot	CT-6024	4
14-27x	ZW433934	Screw, countersunk head 3x6 D=5		1
ASSEMBLY BLOCK				
14-28	BC484143	Wood Frame	CT-6011	1
14-29x	BC531527	Wood Frame B (44D)	CT-6011	1
14-30	SK566008	Volume Knob B	CG-6515	5
14-31x	UM514877	Pre Amp. Shield Plate	CG-5214	1
14-32x	EZ314504	Shield Plate Prop	MR-525	1
14-33x	ZW273756	Nut M3		1
14-34x	EF371698	Fuse ST-4 0.5A	39-1-28	2
14-35x	EF277402	Fuse ST-2 1A	39-1-26	1

INDEX

Parts No.	Ref. No. & Symbol No.	Parts No.	Ref. No. & Symbol No.	Parts No.	Ref. No. & Symbol No.	Parts No.	Ref. No. & Symbol No.	Parts No.	Ref. No. & Symbol No.
BA498767	8-1x	EC329883	11-C27	EO496361	8-L2	ER345712	7-40x	ET453611	13-TR1
BA517882	11-1x	EC331705	9-C7	EO496844	13-T1	ER346544	11-R30	ET465208	9-TR3
BA519131	5-66	EC331817	9-C9	EO550552	11-L4b	ER346601	8-R4	ET465265	9-TR4
BA519131	12-1x	EC331828	9-C5	EP494425	4-64	ER346601	8-R36	ET491051	8-TR5
BA519568	10-1x	EC336126	11-C20	ER211320	11-R24	ER346994	12-R7	ET517263	11-TR1, 2, 3
BA524946	9-1x	EC336148	10-C8	ER211465	8-R38	ER347038	9-R15	ET517274	11-T1
BA554703	13-1x	EC337500	8-C12	ER211465	9-R4	ER347073	11-R41	ET517375	12-TR2
BA557335	12-2x	EC350706	9-C1	ER211465	9-R6	ER349784	9-R9	ET517994	13-TR2, 3
BA557355	5-67x	EC362125	6-29x	ER211465	11-R28	ER349784	9-R12	ET539122	12-TR3
BC456625	2-13	EC362158	10-C5	ER211465	12-R3, 5	ER349907	8-R11	ET539987	9-TR1
BC484143	14-28	EC372148	9-C3	ER211465	13-R2	ER349907	8-R19	EV329152	9-VR1
BC531527	14-29x	EC379157	11-C25	ER211667	8-R8	ER349907	8-R22	EV453396	6-3
BC564006	14-21	EC379170	8-C20	ER211667	9-R5	ER349907	8-R34	EV453420	6-4
BC564344	14-1	EC379765	11-C11	ER211667	11-R33	ER349942	8-R17	EV494436	6-2
BC564355	14-2x	EC379787	8-C3	ER211757	9-R1, 2	ER349942	8-R26	EV499364	8-VR1
BC564388	14-22x	EC389237	11-C14	ER211757	11-R25	ER349942	8-R30	EV499375	8-VR2
BF456658	2-16	EC389237	11-C18	ER211757	11-R29	ER349942	8-R32, 33	EV499882	13-VR1, 2
BH554714	1-1x	EC389237	11-C28, 29	ER211757	11-R35	ER349942	9-R7	EV554668	11-VR2
BM510107	2-1x	EC389485	11-C10	ER211757	11-R39	ER350065	11-R31	EV554670	11-VR1
BM510118	2-2	EC394020	10-C6	ER211858	8-R7	ER352045	9-R8	EWS24845	7-27x
BR451686	3-2x	EC395504	8-C22	ER211858	8-R9	ER357412	11-R26	EW540112	7-25
BR451697	3-1x	EC399565	11-C5	ER212174	8-R13	ER357456	8-R25	EZ246936	7-24x
BT517195	6-38x	EC405898	11-C4	ER212264	8-R14, 15	ER357456	12-R8	EZ314504	14-32x
BT517230	6-39x	EC432652	13-C1	ER212264	11-R6	ER357456	12-R11	EZ315448	7-26x
BT517241	6-37x	EC434070	8-C24	ER212264	11-R14	ER357491	11-R37	EZ328320	4-22x
BT517432	6-36	EC435690	11-C3	ER212264	12-R6	ER357535	8-R23	EZ382263	7-23
BZ459966	5-1x	EC450055	11-C31	ER212264	12-R12	ER357535	9-R10	EZ452992	9-5
BZ517858	4-1x	EC450066	10-C2	ER212477	8-R2	ER357570	8-R12	EZ457176	7-3
BZ517860	4-18x	EC450270	10-C7	ER212477	8-R5	ER357570	8-R16	EZ469721	6-19
BZ519096	7-32x	EC450527	11-C24	ER212477	8-R24	ER357570	11-R8	EZ486617	6-47x
BZ519107	7-33x	EC453431	6-59	ER212477	9-R3	ER361642	8-R40	EZ486797	6-57x
EA498857	6-26	EC487157	11-C22	ER212681	10-R1	ER361642	9-R14	HE554646	1-24
EA514800	6-49x	EC495865	8-C2	ER212681	11-R19	ER361642	13-R3	HL457391	1-3
EA514811	6-48	EC514754	6-53	ER212681	13-R9	ER362441	11-R38	HP536095	1-14
EA516047	5-51	EC524957	11-C17	ER212883	8-R45	ER376413	6-15	HZ457323	1-2
EC220127	11-C1	EC554613	13-C8	ER212883	11-R1	ER379473	11-R16	HZ457367	1-10
EC220151	12-C1, 2	ED219464	8-D1	ER212883	11-R7	ER380711	8-R44	MB456660	2-18
EC220151	13-C3, 4	ED219464	8-D5	ER212883	11-R12	ER380755	11-R2	MB456895	5-23
EC220151	13-C6	ED219464	11-D2	ER212883	11-R15	ER380913	8-R39	MB456917	3-19
EC220364	9-C6	ED453644	9-V1, 2	ER212883	11-R21	ER399723	9-R18	MC516014	4-60
EC220364	11-C16	ED453655	9-TH1	ER212883	11-R34	ER411726	13-R5	MR387606	3-13
EC220432	11-C8	ED491130	8-D2	ER212883	12-R1, 2	ER420322	11-R32	MR456761	5-45x
EC250604	9-C8	ED494583	4-70x	ER212883	13-R7	ER426857	8-R3	MR456838	5-6
EC250661	10-C4	ED498150	13-D5	ER213030	11-R18	ER426857	8-R42, 43	MR456840	5-7
EC250683	8-C5	ED511097	10-D1	ER213030	11-R20	ER430018	11-R36	MR468292	1-4
EC250841	13-C5	ED511097	10-D2, 3, 4	ER213300	11-R42	ER430018	11-R44, 45	MS387573	3-10
EC250841	13-C7	ED511097	13-D1 to 4	ER213467	8-R20, 21	ER430018	12-R10	MS389981	1-5
EC250885	10-C9	ED514721	8-D3, 4	ER213647	6-28x	ER430053	13-R4	MS456851	5-5x
EC251291	8-C15	ED514721	8-D6	ER213647	11-R13	ER430097	8-R28	MS456862	5-9x
EC251291	8-C18	ED515790	12-D1	ER214290	6-23x	ER440921	7-37x	MS457435	4-5
EC251291	8-C21	ED516420	11-D1	ER215234	13-R1	ER450011	8-R35	MS495134	14-9
EC290520	8-C23	ED516420	12-D2	ER304290	9-R13	ER450011	11-R11	MZ456480	4-24
EC290520	13-C9, 10	EF277402	7-22	ER304290	11-R43	ER465276	11-R3	MZ510017	2-3
EC290531	9-C2	EF277402	14-35x	ER304290	13-R6	ER517320	10-R2	SB457413	4-3
EC290564	5-53	EF371698	6-51x	ER304290	13-R8	ER529975	7-38x	SB461406	4-4
EC308711	9-C10	EF371698	14-34x	ER304402	8-R6	ER550811	12-R9	SB499195	5-38
EC313121	8-C9, 10	EF453666	9-F1	ER306360	9-R11	ER557302	9-R16, 17	SE530267	14-5
EC320040	8-C16	EF480892	6-52x	ER306360	11-R23	ES379045	7-36	SK371621	6-14x
EC320051	8-C1	EJ1517342	10-IC1	ER306843	8-R27	ES389700	4-49	SK487675	7-8
EC320051	8-C4	EJ233370	7-20	ER306843	11-R5	ES469541	6-10	SK495202	6-13x
EC320051	8-C6, 7, 8	EJ254970	6-58x	ER306887	8-R29	ES477966	5-26	SK543172	4-13
EC320051	8-C14	EJ315281	6-17	ER306887	8-R41	ES490432	4-20	SK543172	6-12
EC320051	8-C17	EJ345857	6-55x	ER306887	10-R4	ES491962	4-46	SK566008	14-30
EC320051	8-C19	EJ345857	7-28x	ER306887	11-R27	ES494076	11-SW1	SM518185	14-3
EC320051	9-C4	EJ350447	8-2x	ER306887	11-R40	ES494188	4-14	SM518310	14-7
EC320051	10-C1	EJ376604	6-20	ER315213	7-39x	ES494594	7-7	SM518760	7-15
EC320051	11-C2	EJ510353	5-58	ER324685	6-27x	ES499972	6-11x	SM518771	7-18x
EC320051	11-C7	EJ514822	6-50x	ER336442	8-R1	ES516036	5-50	SM518793	7-17x
EC320051	11-C9	EJ518872	7-34	ER336442	8-R31	ES517151	5-64	SM518804	7-19x
EC320051	11-C13	EJ518883	7-35x	ER336442	10-R3	ES539043	5-37	SM530561	7-16x
EC320051	11-C19	EL295312	7-4	ER336442	11-R4	ET234854	8-TR1	SM531516	14-4x
EC320051	11-C21	EL390576	7-11	ER336442	11-R10	ET234854	8-TR6	SP494122	14-25x
EC320051	11-C26	EM517296	6-30x	ER336442	11-R13b	ET304255	9-TR2	SP518376	14-16
EC320051	11-C32, 33	EM517296	7-12	ER342933	11-R17	ET329218	8-TR2	SP531505	14-17x
EC321208	10-C3	EM561745	6-31x	ER342933	11-R46	ET329218	8-TR4	SZ484121	14-26x
EC329771	11-C6	EM561745	7-13x	ER343078	8-R10	ET329218	8-TR8	UC370348	3-8
EC329771	11-C15	EO243988	11-L2	ER343078	8-R18	ET350335	8-TR7	UC370372	3-9
EC329771	11-C23	EO368403	11-L1	ER343078	8-R37	ET352146	8-TR3	UM366625	1-17
EC329861	8-C13	EO368403	11-L4	ER343078	11-R9	ET398777	11-TR4 to 8	UM387268	2-20
EC329883	8-C11	EO496350	8-L1	ER343078	11-R22	ET398777	12-TR1	UM387617	3-15x

INDEX

Parts No.	Ref. No. & Symbol No.	Parts No.	Ref. No. & Symbol No.	Parts No.	Ref. No. & Symbol No.	Parts No.	Ref. No. & Symbol No.	Parts No.	Ref. No. & Symbol No.
UM387630	3-14	UM518657	10-2	ZW417137	14-20				
UM387641	3-16	UM518668	10-3x	ZW417148	2-7				
UM389790	3-5	UM518758	7-1	ZW417194	10-4				
UM394200	3-18	UM518837	7-6	ZW417227	1-22				
UM399071	1-23	UM518850	4-73	ZW417227	9-6				
UM452834	4-19	UM518850	6-34	ZW417251	3-20x				
UM453060	14-13	UM518861	7-14	ZW417273	1-20				
UM453262	14-23x	UM530302	6-32x	ZW417273	4-41				
UM456671	2-11	ZG224796	5-30	ZW417273	5-35				
UM456682	2-19	ZG345262	5-3	ZW417328	4-16x				
UM456693	5-41	ZG367301	4-55	ZW419736	6-44x				
UM456726	5-42	ZG370361	3-7	ZW421007	5-18				
UM456750	5-43	ZG385075	3-6	ZW433934	14-27x				
UM456783	5-2	ZG387584	3-12	ZW437084	6-18				
UM456827	5-4	ZG387821	4-59	ZW442585	5-40x				
UM456928	4-28	ZG453115	14-12	ZW447772	4-23x				
UM456941	4-34	ZG456186	4-72	ZW447772	4-27				
UM456952	4-35	ZG456930	4-29	ZW447772	4-47				
UM456963	4-33	ZG456985	5-33	ZW447772	4-74				
UM456974	5-32	ZG457244	4-52	ZW447772	5-28				
UM456996	5-29	ZG457378	1-9	ZW447772	5-57				
UM457018	4-30	ZG457380	1-7	ZW447772	5-68				
UM457053	5-59	ZG459224	5-16	ZW447772	6-7				
UM457075	4-48	ZG460484	5-34	ZW447772	6-46				
UM457097	4-39	ZG465636	1-13	ZW447772	6-56x				
UM457108	4-37	ZG469315	5-46	ZW447772	6-61				
UM457110	4-45	ZG469372	14-15	ZW447772	7-10				
UM457121	4-40	ZG494381	5-63	ZW447772	7-29				
UM457132	4-42	ZG494403	4-71	ZW447840	6-33x				
UM457198	4-43	ZG512144	6-60	ZW452373	4-11				
UM457200	4-56	ZG512842	5-61	ZW461248	5-47				
UM457233	4-51	ZG514440	4-10	ZW461261	4-15x				
UM457255	4-53	ZG514675	4-8	ZW461261	4-50				
UM457266	4-75	ZG516418	4-36	ZW461261	5-27				
UM457312	3-3	ZW259795	5-17	ZW461272	2-17x				
UM457424	4-7	ZW259885	4-38	ZW461395	1-18				
UM461586	5-14x	ZW259986	4-31	ZW461452	9-2x				
UM461878	5-12	ZW270088	1-8	ZW461452	9-4				
UM461880	5-13	ZW270088	3-17	ZW462881	1-12				
UM461891	5-15	ZW270088	4-12	ZW462881	5-55				
UM462690	5-11x	ZW270088	4-69	ZW462925	2-10				
UM470452	6-40	ZW270123	5-10	ZW464692	2-14				
UM483412	14-24x	ZW270191	6-22	ZW464703	5-39x				
UM483906	4-58	ZW273633	1-21x	ZW468112	6-42x				
UM483930	4-25	ZW273688	1-19	ZW474581	5-21				
UM483930	6-9	ZW273688	4-17x	ZW474581	5-44x				
UM483941	4-26	ZW273756	2-8	ZW474592	5-22				
UM483985	6-41	ZW273756	10-5	ZW474603	5-24x				
UM484042	6-8	ZW273756	13-4x	ZW478697	5-62				
UM494190	5-25	ZW273756	14-33x	ZW478991	2-21				
UM494291	4-67	ZW273767	5-65x	ZW481645	4-66x				
UM494392	4-65	ZW273778	4-57x	ZW481724	7-21x				
UM494414	4-68	ZW273881	7-30x	ZW483456	4-63				
UM494458	6-35	ZW273914	6-43x	ZW514697	4-44				
UM494537	7-2	ZW290283	4-6	ZW516251	5-54				
UM494987	2-15	ZW290283	4-32	ZW517083	7-9x				
UM495145	14-10	ZW290283	4-54	ZW517318	7-5				
UM496596	6-25	ZW290283	5-19	ZW530504	5-49x				
UM498216	4-2	ZW290283	5-31						
UM498892	5-36	ZW290283	5-48						
UM510041	2-9	ZW290283	14-14						
UM514833	6-54	ZW323728	6-24						
UM514877	14-31x	ZW323728	9-3x						
UM515518	5-52	ZW323728	14-11						
UM515575	4-9	ZW355307	3-11						
UM515935	4-62x	ZW356804	2-4						
UM516025	4-61x	ZW364342	3-4						
UM516306	2-6	ZW371856	6-5						
UM516352	2-5	ZW376481	6-21						
UM516598	6-45x	ZW379405	4-21						
UM518027	6-6	ZW381644	5-8x						
UM518038	6-16	ZW391397	1-6						
UM518106	5-60	ZW391397	5-20						
UM518117	5-56	ZW413223	7-31x						
UM518297	14-6	ZW413728	13-5						
UM518308	14-8	ZW413741	13-3						
UM518400	14-18	ZW414235	1-15						
UM518411	14-19	ZW414246	1-16						
UM518501	6-1	ZW417025	2-12						
UM528646	13-2	ZW417137	1-11						

SECTION 3

SCHEMATIC DIAGRAM

1. GXC-38 SCHEMATIC DIAGRAM
2. GXC-44D SCHEMATIC DIAGRAM

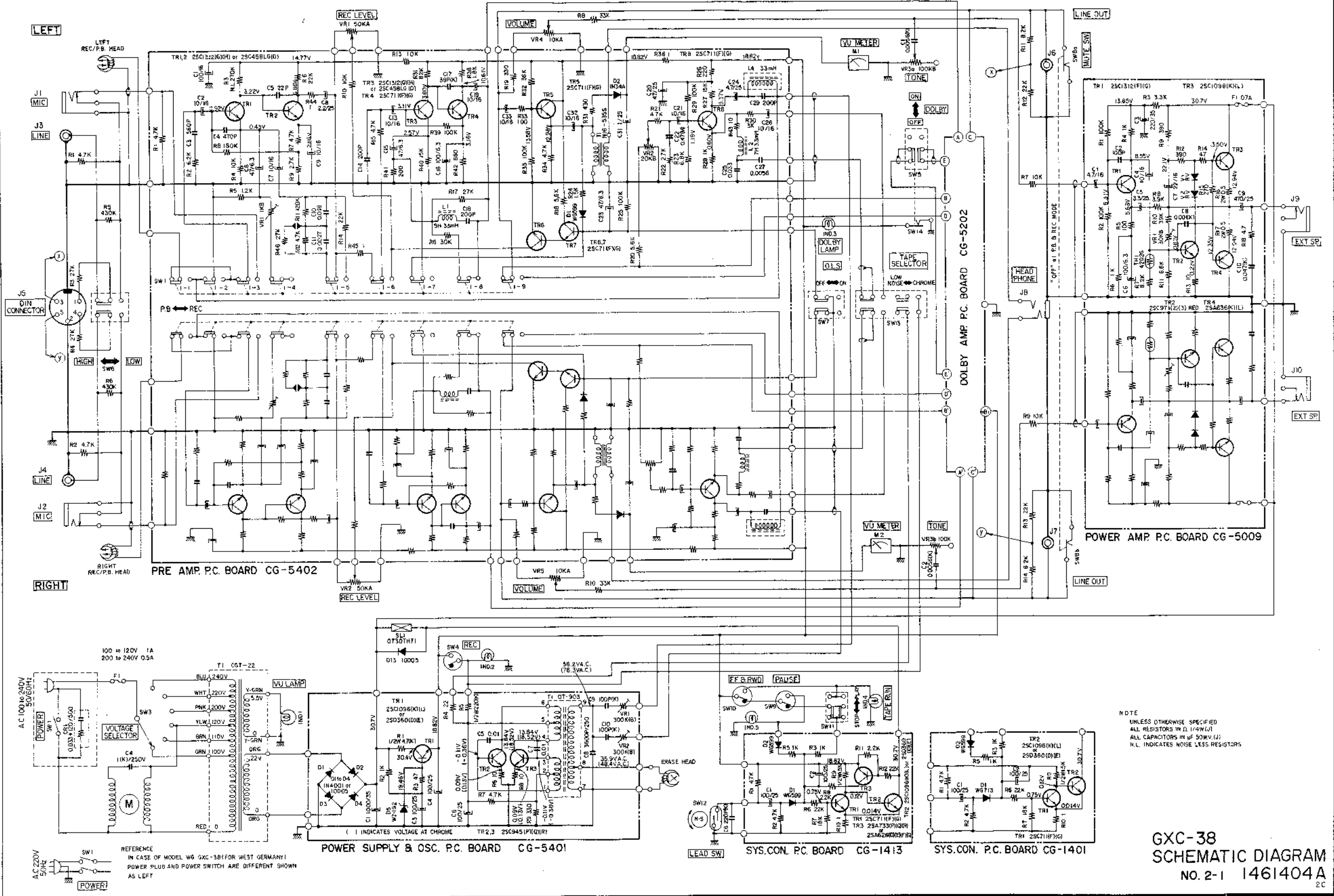

NOTE
UNLESS OTHERWISE SPECIFIED
ALL RESISTORS IN Ω, 1/4W (1)
ALL CAPACITORS IN μF 50WV (1)
N.L. INDICATES NOISE LESS RESISTORS

GXC-38/D

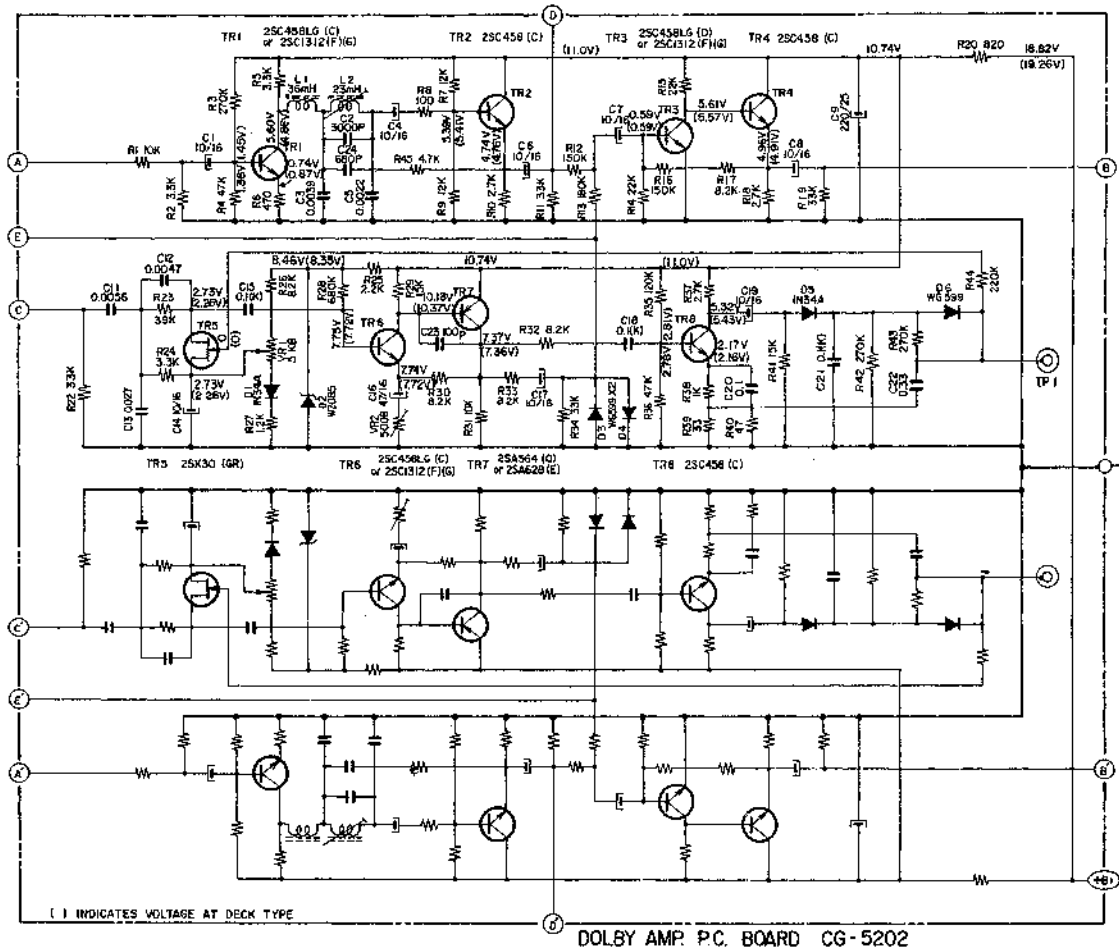

NOTE
UNLESS OTHERWISE SPECIFIED
ALL RESISTORS IN Ω 1/4W(J)
ALL CAPACITORS IN μ F 50WV(J)

GXC-38/D
SCHEMATIC DIAGRAM
1461407A
2C

GXC-440

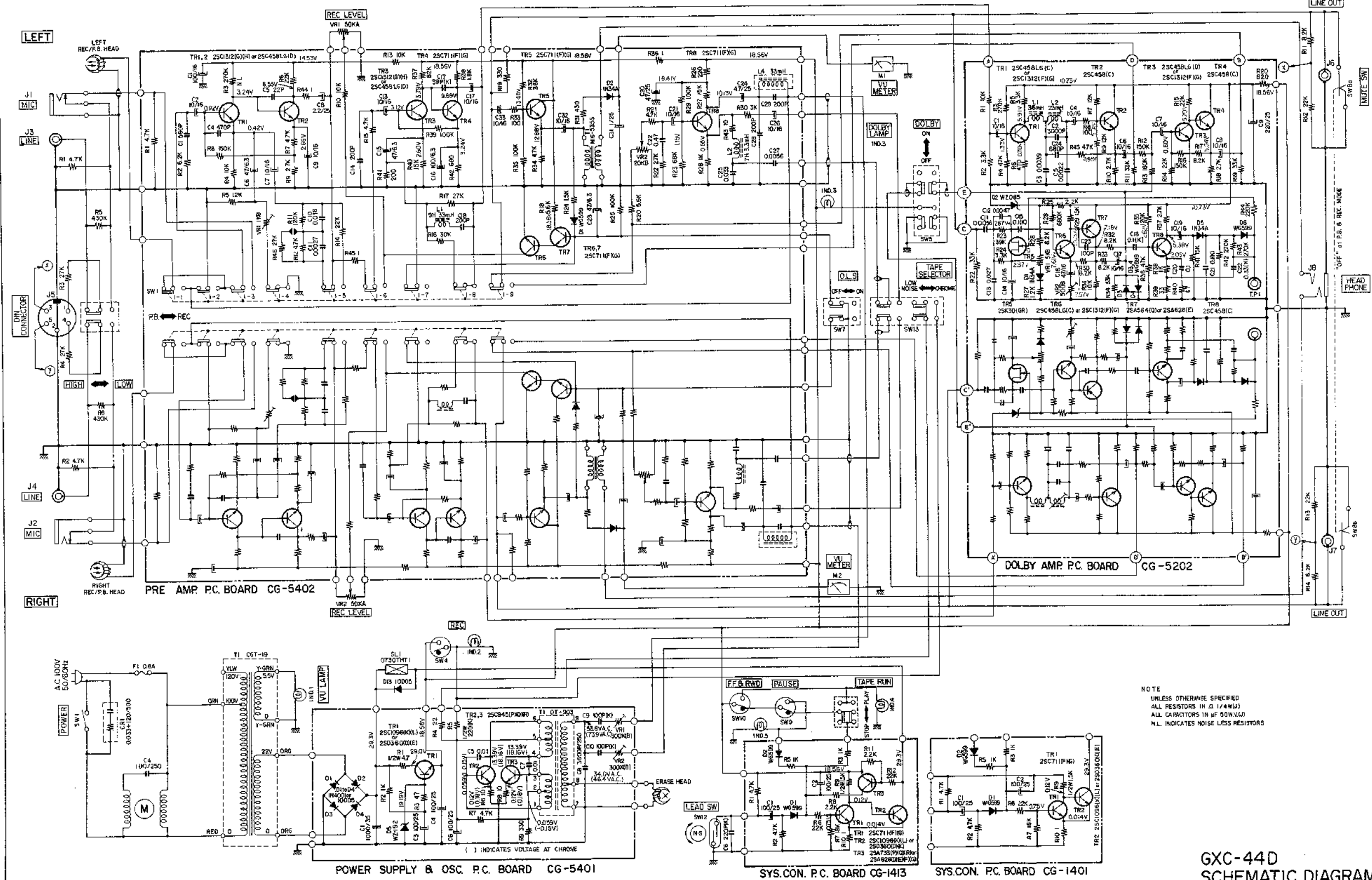

GXC-440
SCHEMATIC DIAGRAM
No. 1461408A
2C