

AKAI

AS-980

MODEL

SERVICE MANUAL

SERVICE MANUAL
PARTS LIST
4-CH/STEREO RECEIVER
MODEL AS-980



4-CH/STEREO RECEIVER

MODEL AS-980

SECTION 1	SERVICE MANUAL	2
SECTION 2	PARTS LIST	51
SECTION 3	SCHEMATIC DIAGRAM	63

SECTION 1
SERVICE MANUAL

TABLE OF CONTENTS

I. SPECIFICATIONS	3
II. DISMANTLING OF UNIT	6
III. ARRANGEMENT OF MAIN PARTS	7
IV. NECESSARY MEASURING INSTRUMENTS	8
V. CLASSIFICATION AND INTERCHANGEABILITY OF VARIOUS P.C. BOARDS	9
VI. FM TUNER SECTION ADJUSTMENTS	10
1. FM IF CIRCUIT ADJUSTMENT	10
2. FRONT END AND FM IF MATCHING ADJUSTMENT	13
3. TRACKING ADJUSTMENT	14
4. SENSITIVITY ADJUSTMENT	14
5. SIGNAL METER SENSITIVITY ADJUSTMENT	15
6. STEREO SEPARATION ADJUSTMENT	15
7. TUNING METER CENTER ADJUSTMENT	15
8. MUTING LEVEL ADJUSTMENT (STEREO INDICATOR SENSITIVITY ADJUSTMENT)	15
VII. AM TUNER SECTION ADJUSTMENTS	18
1. AM IF CIRCUIT ADJUSTMENT	18
2. TRACKING ADJUSTMENT	19
3. SENSITIVITY ADJUSTMENT	19
VIII. TUNING CORD THREADING	21
IX. CD-4 ADJUSTMENTS	22
1. SERVICING AND ADJUSTING THE CD-4 DEMODULATOR	22
2. SERVICE POINTS FOR THE CD-4 PLAYBACK SYSTEM	30
X. CD-4 P.C. BOARD OPERATION	32
XI. SQ & RM OPERATION PRINCIPALS	34
XII. POWER AMPLIFIER ADJUSTMENTS	37
XIII. COMPOSITE VIEWS OF COMPONENTS	42

I. SPECIFICATIONS

An asterisk next to a figure indicates the minimum guaranteed performance.

§ AMPLIFIER SECTION

RATEO OUTPUT	4 CHANNEL	32W at 8Ω (1 ch operation 1 kHz 0.5%)
	2 CHANNEL POWER DOUBLER	50W at 8Ω (1 ch operation 1 kHz 0.5%)
FREQUENCY RESPONSE	PHONO	100 Hz 13±1.5 dB
		10 kHz -13±1.5 dB
	AUX	20 Hz*-2.0 dB 50 kHz*-3.0 dB
POWER BAND WIDTH		10 Hz to 50 kHz at 8Ω
INPUT SENSITIVITY	PHONO	3 mV (-48±1.5 dB)
	MIC	3 mV (-48±1.5 dB)
	AUX	170 mV (-13±1.5 dB)
	TAPE 1, 2	170 mV (-13±1.5 dB)
	TAPE 3	155 mV (-14±1.5 dB)
SIGNAL TO NOISE RATIO	PHONO 1, 2	Better than 35 dB
	MIC	Better than 35 dB
	AUX-DISC 4 CH	Better than 40 dB
	AUX-SQ	Better than 35 dB
	TAPE 1, 2	Better than 40 dB
	TAPE 3	Better than 45 dB
	CD-4	Better than 35 dB (CD-4 Sep. Volume center)
RESIDUAL NOISE		Less than 4.3 mV (Less than -45 dB)
TONE CONTROL	BASS	10±1.5 dB at 100 Hz
		-10.5±1.5 dB at 100 Hz
	TREBLE	10±1.5 dB at 10 kHz
		-10±1.5 dB at 10 kHz
LOUDNESS CONTROL		9±2 dB at 100Hz
		5±2 dB at 10kHz
FILTER	HIGH CUT	-7±1.5 dB at 10kHz
	LOW CUT	-6±1.5 dB at 50 Hz
AUDIO MUTE		-20±2 dB
CROSS TALK		Better than 50 dB
LEFT/RIGHT DEVIATION		Within -3 dB
FRONT/REAR DEVIATION		Within -3 dB
RECORDING OUTPUT	TAPE 1 DIN	34 mV (-27±1.5 dB)
	PIN	170 mV (-13±1.5 dB)
	TAPE 2 PIN	170 mV (-13±1.5 dB)
	TAPE 3 PIN	140 mV (-15±1.5 dB)
DISTORTION FACTOR		Less than 0.1% (8Ω, 10 W output power)

§ SQ SECTION

	Input		F.L	F.R	R.L	R.R
CROSS TALK	F.L	1 kHz	20±2 dBm	Less than -5 dBm	17±2 dBm	17±2 dBm
	F.R	1 kHz	Less than -5 dBm	20±2 dBm	17±2 dBm	17±2 dBm
	F.L+F.R	1 kHz	20±2 dBm	20±2 dBm	-13±2 dBm	13±2 dBm
	F.L-F.R	1 kHz	14±2 dBm	14±2 dBm	20±2 dBm	20±2 dBm
PHASE DEVIATION	F.L	100Hz	0°		90±20°	
	F.L	1 kHz	0°		90±20°	
	F.L	10 kHz	0°		90±20°	
	F.R	100 Hz		0°		-90±20°
	F.R	1 kHz		0°		-90±20°
	F.R	10 kHz		0°		-90±20°

§ RM SECTION

	F.L	1 kHz	18±2 dBm	7±2 dBm	16±2 dBm	12±2 dBm
CROSS TALK	F.L	1 kHz	18±2 dBm	7±2 dBm	16±2 dBm	12±2 dBm
	F.R	1 kHz	7±2 dB	18±2 dBm	12±2 dBm	16±2 dB
PHASE DEVIATION	F.L	100 Hz	0°		-90±20°	
	F.L	1 kHz	0°		-90±20°	
	F.L	10 kHz	0°		-90±20°	
	F.R	100 Hz		0°		90±20°
	F.R	1 kHz		0°		90±20°
	F.R	10 kHz		0°		90±20°

§ FM TUNER SECTION

FREQUENCY RANGE	J 75 to 91±1 MHz U 86 to 109±1 MHz
DIAL TRACKING ERROR	±250 kHz
SENSITIVITY (IHF)	1.8 μV * 2.8 μV (9 dB)
SENSITIVITY DEVIATION	Within 3 dB
IMAGE REJECTION RATIO	J, U Better than 85 dB
IF REJECTION RATIO	J, U Better than 100 dB
CAPTURE RATIO (IHF)	Less than 1.5 dB
LIMITING SENSITIVITY	Less than 8 dB
MUTING SENSITIVITY	20±3 dB
SELECTIVITY	Better than 80 dB
AM SUPPRESSION RATIO	Better than 45 dB
SIGNAL TO NOISE RATIO	70 dB STEREO *Better than 50 dB MONAURAL *Better than 60 dB
DISTORTION FACTOR	STEREO 0.6% *Less than 1.5% MONAURAL 0.2% *Less than 0.5%
FREQUENCY RESPONSE	J -11±1 dB at 10 kHz U -13±1 dB at 10 kHz
STEREO SENSITIVITY	Less than 20 μV (Less than 26 dB)
STEREO INDICATOR SENSITIVITY	Less than 20 μV (Less than 26 dB)
STEREO SEPARATION	40 dB *Better than 35 dB
REJECTION RATIO	Better than 50 dB
LEFT-RIGHT DEVIATION	Within 3 dB
RECORDING OUTPUT	PIN 390 mV (-6±3 dB) DIN 70 mV (-21±3 dB)

§ AM TUNER SECTION

FREQUENCY RANGE	525±5 kHz to 1,650±20 kHz
DIAL TRACKING ERROR	Within 2%
SENSITIVITY (IHF)	250 μV (48 dB)
SENSITIVITY DEVIATION	Within 6 dB
IMAGE REJECTION RATIO	80 dB *Better than 60 dB at 1 MHz
IF REJECTION RATIO	75 dB *Better than 60 dB at 1 MHz
SELECTIVITY	35 dB *Better than 30 dB ±10 kHz
SIGNAL TO NOISE RATIO	50 dB *Better than 40 dB
DISTORTION FACTOR	0.8% *Less than 1.5%
FREQUENCY RESPONSE	-15 dB at 3 kHz
RECORDING OUTPUT	PIN 140 mV (-15±2 dB) DIN 27 mV (-19±2 dB)

§ OTHER

TRANSISTORS	2SA628(E) ... 5	2SC922(L) ... 2
	2SA706-3(J)(Z) ... 4	2SC945(P)(Q)(R) ... 1
	2SA733(Q)(R) ... 3	2SC1096(K)(L) ... 1
	2SC4581(G)(C) ... 6	2SC1124(I)(J)(K) ... 8
	2SC711(E)(F) ... 33	2SC1312(F)(G) ... 46
	2SC733(P)(Q)(R) ... 1	2SC1403(O)(Y) ... 8
	2SC839(H) ... 4	2SD313(E)(F) ... 1
	2SC853(L) ... 1	
	2SK30Y(GR) ... 3	2SK40-2 ... 4
	FET	LA1221 ... 4
I.C.	LA3300 ... 1	
DIODES	1N34A ... 25	7S990 ... 6
	1N60 ... 7	FR2-02 ... 4
	1N4002 ... 12	H1F1400V3A ... 8
	1S188FM ... 8	WG599 ... 1
ZENER DIODES	WZ130 ... 2	ZB1-12 ... 5
VARIABLES	STV-3H ... 4	
POWER SOURCE	100 to 240V.A.C. 50/60 Hz	
	120V.A.C. 60 Hz (CSA models)	
POWER CONSUMPTION	380W/4Ω (at maximum output)	
	250W/4Ω (at 1/3 output)	
DIMENSIONS	650(W) x 168 (H) x 426(D) mm (25.6" x 6.6" x 16.8")	
WEIGHT	20.5 kg (45.1 lbs.)	

NOTE: Specifications subject to change without notice.

II. DISMANTLING OF UNIT

In case of trouble, etc. necessitating disassembly, please disassemble in the order shown in photographs. Reassemble in reverse order.

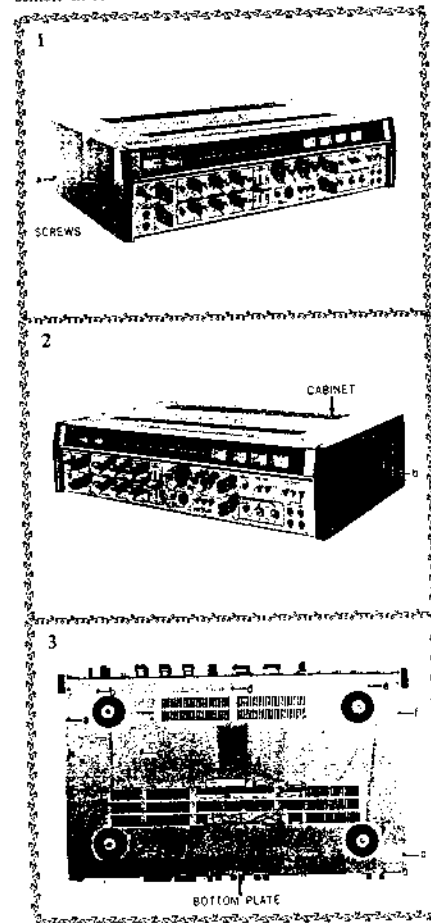

III. ARRANGEMENT OF MAIN PARTS

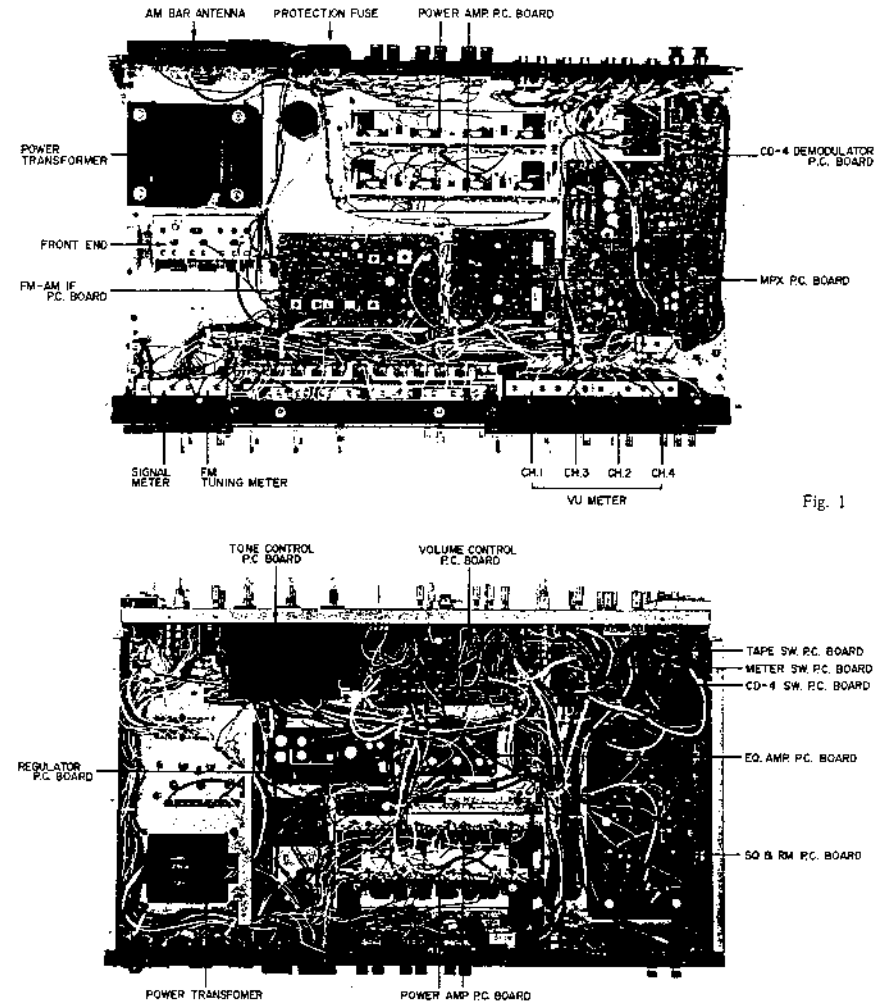

IV. NECESSARY MEASURING INSTRUMENTS

Measuring Instrument	Model	For
AM-FM Radio IF Genescope	Meguro MSW-721C	FM/AM IF Adjustment
FM Standard Signal Generator	Meguro MSG-278G	FM Tracking, Sensitivity Adjustment
FM Stereo Modulator	Meguro MSG-211E	FM Stereo Separation Adjustment
AM Standard Signal Generator	Meguro MSG-221C	AM Tracking, Sensitivity Adjustment
AM Loop Antenna	Meguro MLA-1001B	AM Tracking, Sensitivity Adjustment
SCA Signal Generator	Meguro MSG-212A	CD-4 Adjustment
Audio Frequency Oscillator	Kikusui 418	CD-4 Adjustment
Attenuator	Kikusui 988-1	CD-4 Adjustment
Oscilloscope	National VP-508A	CD-4 Adjustment
High Sensitivity V.T.V.M.	Kikusui 183E	Tuner/Amp. Section Adjustment
Distortion Meter	Shibasoku 760C	Tuner/Amp. Section Adjustment
Ampere Meter	Yokogawa 2011	Amp. Section Adjustment

Chart 1

V. CLASSIFICATION AND INTERCHANGEABILITY OF VARIOUS P.C. BOARDS

P.C. Board	Model	Model				
		AS-970	AS-960	AA-940	AA-930	AA-920
DIAL ILLUMINATION P.C. BOARD	98-5001	97-5008	97-5008	AA-5029	AA-5029	AA-5029
TAPE SWITCH P.C. BOARD	98-5002	97-5004	96-5001			
METER SWITCH P.C. BOARD	98-5003	97-5001				
CD-4 SWITCH P.C. BOARD	98-5004	97-5003	96-5003			
CD-4 SEPARATION VOL. P.C. BOARD	98-5005					
VOLUME P.C. BOARD	98-5008	98-5006				
-tone CONTROL P.C. BOARD	98-5007	98-5007	96-5006	94-5025	94-5025	92-5010
EQUALIZER AMP. P.C. BOARD	98-5008	98-5008	96-5004	94-5012	94-5012	92-5003
RECT. P.C. BOARD	98-5010	98-5010	98-5010			
LAMP RECT. P.C. BOARD	98-5011	98-5011				
HEADPHONE P.C. BOARD	98-5012	98-5012	98-5012	94-5022	94-5022	94-5022
DUB. P.C. BOARD	98-5013		98-5013			
FILTER & REMOTE P.C. BOARD	98-5014A,B					
SQ AMP. P.C. BOARD	98-5015	97-5010	97-5010			
LOUDNESS SWITCH P.C. BOARD	98-5016		96-5005			
MIC P.C. BOARD	98-5059		95-5059	94-5021	94-5021	94-5021
RESISTOR P.C. BOARD	98-5060					
REGULATOR P.C. BOARD	98-5084	98-5084*	98-5084*			
CD-4 DEMODULATOR P.C. BOARD	TDM-7					
MPX. P.C. BOARD	94-5008	94-5008*	91-5033	94-5008	94-5008	94-5008
FM-AM IF P.C. BOARD	94-5009	94-5009*	91-5033	94-5009	94-5009	94-5009
POWER AMP. P.C. BOARD	92-5005	97-5009	96-5008	94-5013	94-5013	92-5005

NOTE: * ... No Interchangeable

Chart 2

VI. FM TUNER SECTION ADJUSTMENTS

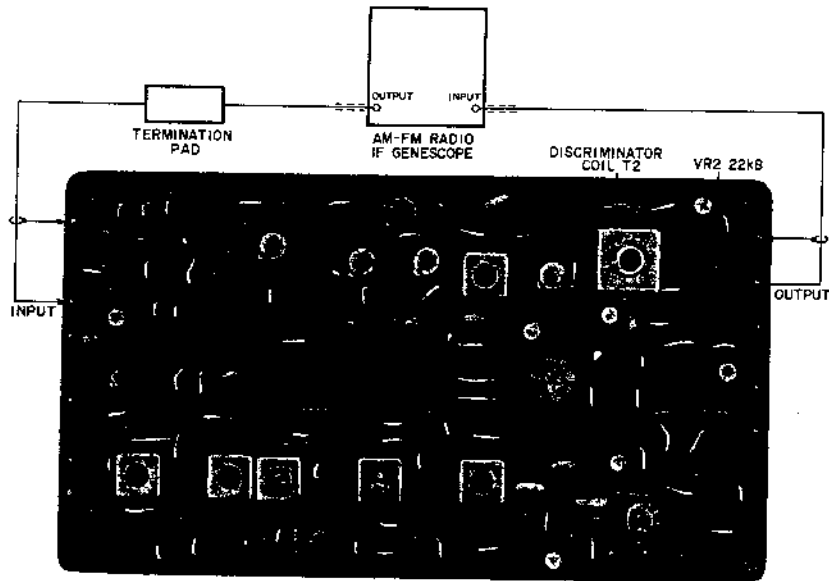

Fig. 3 INSTRUMENT CONNECTIONS

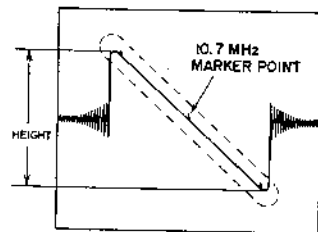

Fig. 4

Vertical Gain	0.3V _{p-p} to 1 cm
GENESCO Output Level	50 dB
Discriminator Coil	T2
S Curve Height	5 cm

Chart 3

1. FM IF CIRCUIT ADJUSTMENT

- 1) Connect the lead wires from an AM-FM Radio IF GENESCOPE (hereinafter referred to as GENESCO) to the input as well as the output of the FM-AM IF P.C. Board as shown in Fig. 3.
- 2) Set GENESCO to FM mode and adjust vertical gain (refer to Chart 3).
- 3) Set Receiver SELECTOR to FM AUTO, and tuning indicator needle to extreme right end of the dial. At this time confirm that a noise element does not enter the S Curve shown in Fig. 4.
- 4) Adjust output level of GENESCO (refer to Chart 3).
- 5) Manually center FM-AM IF P.C. Board semi-fixed resistor VR2 22 kΩ.
- 6) Adjust the upper and lower cores of Discriminator Coil so that the wave height value of the S Curve shown in Fig. 4 is maximum and the linearity of the part indicated by the dotted line is optimum. (Refer to Fig. 4 and Chart 3)

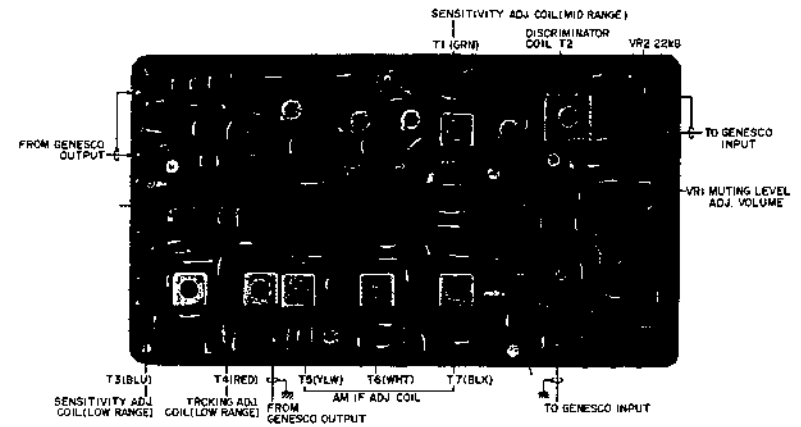

Fig. 5 FM-AM IF P.C. BOARD 94-5009

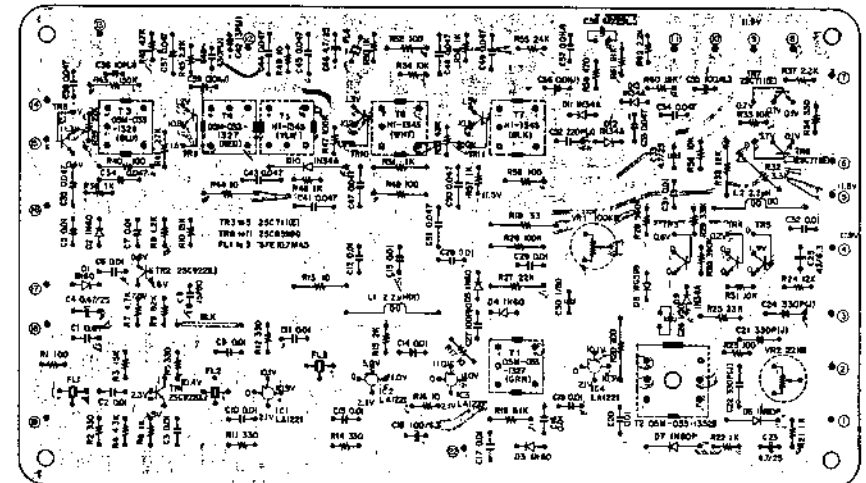
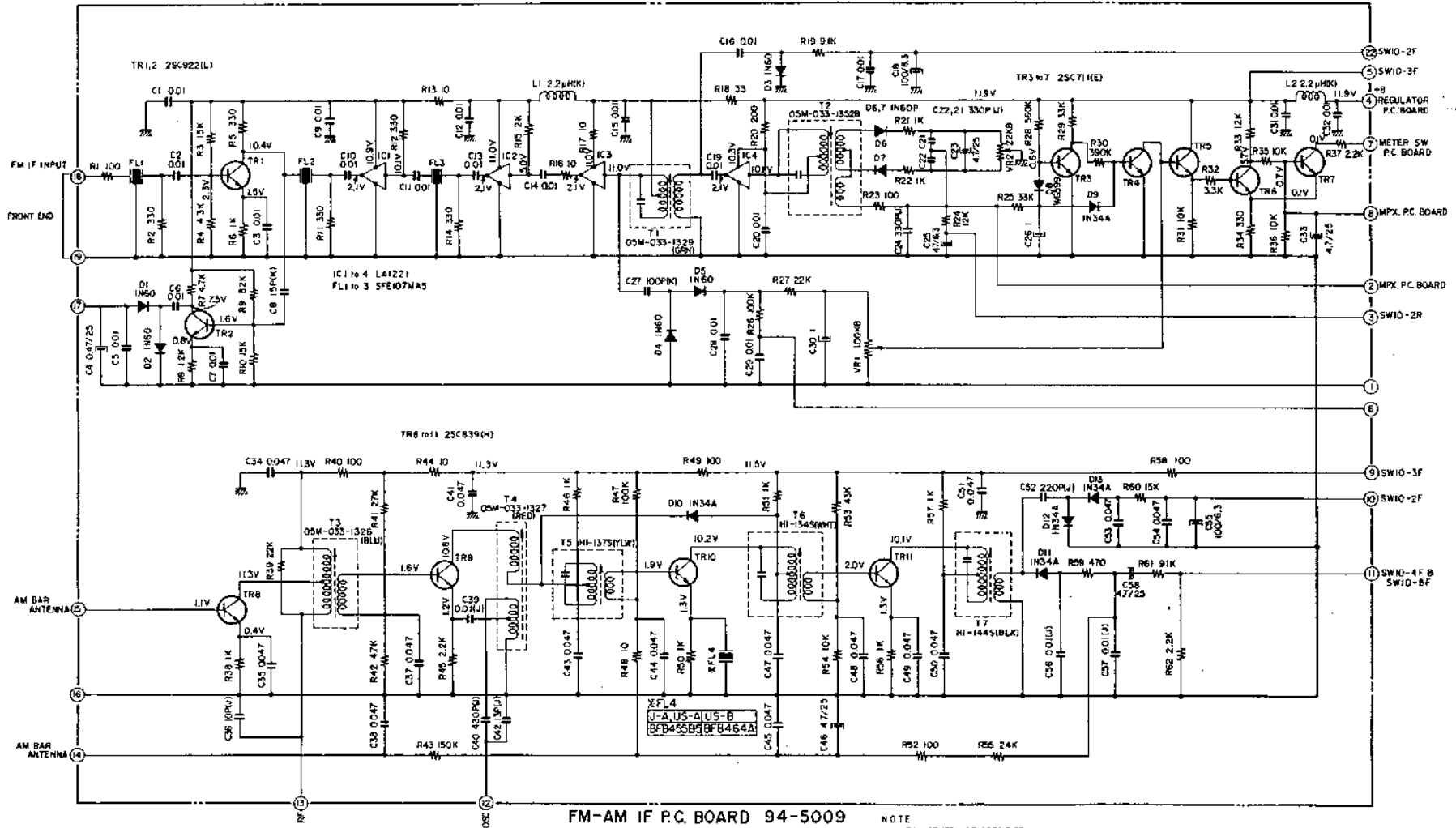

Fig. 6 FM-AM IF P.C. BOARD 94-5009 (Rev.)



FM-AM IF P.C. BOARD 94-5009

NOTE
 UNLESS OTHERWISE SPECIFIED
 ALL RESISTORS IN Ω 1/4W(1)
 ALL CAPACITORS IN pF 50WV(2)

SCHEMATIC 1

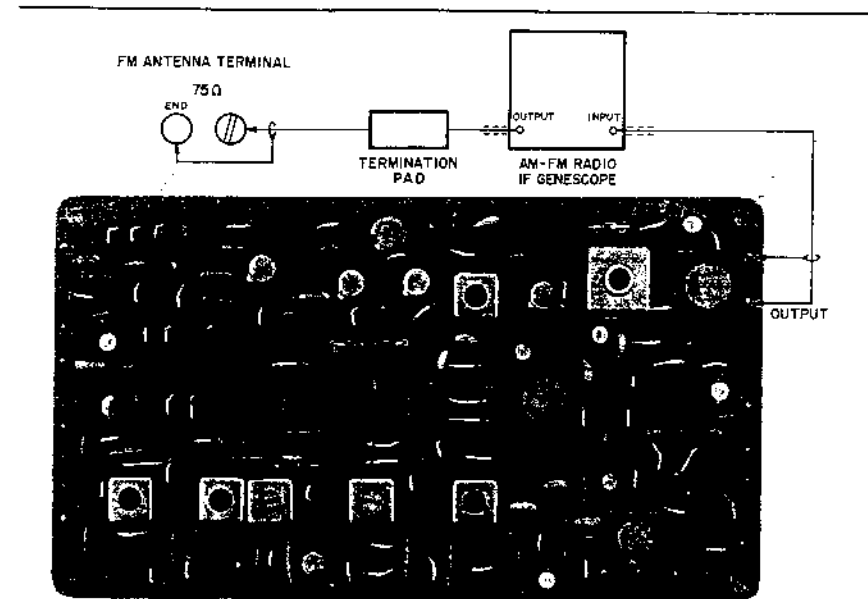

Fig. 7 INSTRUMENT CONNECTIONS

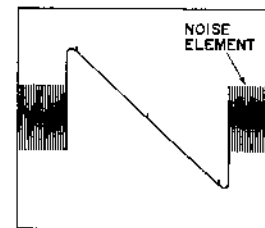

Fig. 8

2. FRONT END AND FM IF MATCHING ADJUSTMENT

- 1) Connect the GENESCOPE lead wires to the 75Ω FM ANTENNA TERMINALS of the Receiver as well as to the FM IF P.C. Board output as shown in Fig. 7.
- 2) Set the GENESCOPE to FM mode and adjust the vertical gain of GENESCOPE to obtain a 10 mm amplitude of the 0.3Vp-p calibration voltage on GENESCOPE Screen and set the GENESCOPE attenuator to 100 dB.
- 3) Set Receiver SELECTOR to FM AUTO, and tuning indicator needle to extreme right end of the dial.
- 4) Adjust the upper core of Front End IF Coil (see Fig. 18) to obtain maximum wave height value of S Curve in Fig. 8, and adjust the lower core to obtain maximum noise level.
- 5) Make this adjustment again following FM Sensitivity Adjustment.

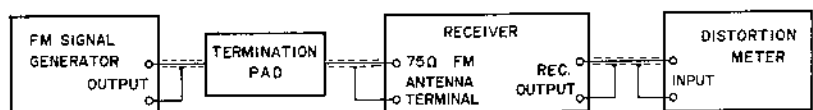
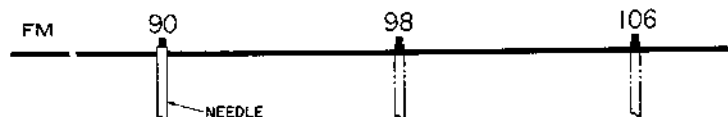

Fig. 9 INSTRUMENT CONNECTIONS



Ref. In making Tracking Adjustments, set dial to following positions.

Fig. 10

FM S.G. Output	40 dB
Core (Low Range)	Lo
Trimmer Condenser (High Range)	TCo

Chart 4

Core (Low Range)	LR2, LRI, LA
Trimmer Condenser (High Range)	TCR2, TCR1, TCA
IF Coil (Mid Range)	IF
Discriminator Coil (Mid Range)	T2

Chart 5

3. TRACKING ADJUSTMENT

- 1) Connect the various measuring instruments as shown in Fig. 9.
- 2) Set the oscillation frequency of the FM SIGNAL GENERATOR (hereinafter referred to FM S.G.) to 90 MHz (400 Hz 100% internal modulation), and set the output of the FM S.G. to 46 dB. (Refer to Chart 4)
- 3) Set Receiver SELECTOR to FM AUTO, and tuning indicator needle to 90 MHz. (Refer to Fig. 10)
- 4) Adjust Core Lo of Front End (Fig. 18) until the distortion meter level is maximum and the distortion factor is minimum. (Refer to Chart 4)
- 5) Set the oscillation frequency of FM S.G. and tuning indicator needle to 106 MHz. (Refer to Fig. 10)
- 6) Adjust trimmer condenser TCo of Front End (Fig. 18) until the distortion meter level is maximum and the distortion factor is minimum. (Refer to Chart 4)

4. SENSITIVITY ADJUSTMENT

- 1) Carry out these adjustments after the previously described Tracking Adjustments have been completed.
- 2) Measuring instrument connections are the same as described in Tracking Adjustments.
- 3) Set the oscillation frequency of the FM S.G. to 90 MHz (400 Hz, 100% internal modulation), set Receiver SELECTOR to FM AUTO, and set the tuning indicator needle to 90 MHz. (Refer to Fig. 10)
- 4) Adjust the FM S.G. Attenuator to obtain a 3% distortion factor.
- 5) Adjust the cores of Front End (Fig. 18) until the distortion meter level is maximum and the distortion factor is minimum. (Refer to Chart 5)
- 6) Set the oscillation frequency of FM S.G. and tuning indicator needle to 106 MHz. (Refer to Fig. 10)
- 7) Adjust the FM S.G. Attenuator to obtain a 3% distortion factor.
- 8) Adjust Trimmer Condensers of Front End (Fig. 18) until the distortion meter level is maximum and the distortion factor is minimum. (Refer to Chart 5)

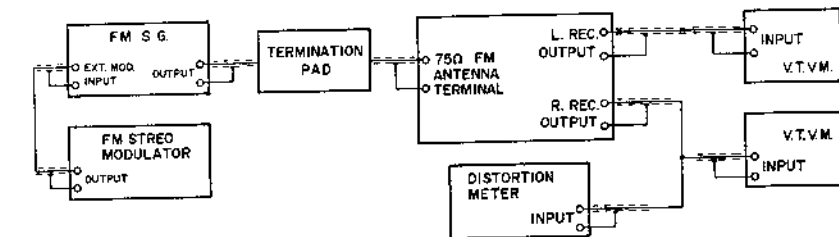

Fig. 11 INSTRUMENT CONNECTIONS

- 9) Set the oscillation frequency of FM S.G. and the tuning indicator needle to 98 MHz. (Refer to Fig. 10)
- 10) Adjust the FM S.G. Attenuator to obtain a 3% distortion factor.
- 11) Adjust the upper and lower cores of IF Coil in Front End (Fig. 18) and the lower core of FM-AM IF P.C. Board Discriminator Coil until the distortion meter level is maximum and the distortion factor is minimum. (Refer to Chart 5)
- 12) Repeat adjustments outlined in Items 3) through 11) at 90 MHz, 98 MHz and 106 MHz two or three times for highest sensitivity.

5. SIGNAL METER SENSITIVITY ADJUSTMENT

- 1) Supply a 98 MHz (400 Hz, 100% internal modulation) 60 dB signal to the Receiver from the FM S.G. Alignment is attained when the tuning meter indicator comes to the exact center of the meter.
- 2) Under the above conditions, adjust the core of Coil T1(GRN) of FM-AM IF Amp. P.C. Board to obtain maximum signal meter indication.

6. STEREO SEPARATION ADJUSTMENT

- 1) Connect the various measuring instruments as shown in Fig. 11.
- 2) Set the FM STEREO MODULATOR pilot signal 19 kHz to 10%, and the main signal 400 Hz (left channel+right channel) to 90% modulation, and supply this composite signal (ratio 9:1) to the EXT MOD. input terminal of the FM S.G.
- 3) Set the FM S.G. oscillation frequency to 98 MHz, and the Attenuator to 66 dB.
- 4) Set Receiver SELECTOR to FM AUTO; and the tuning indicator needle to 98 MHz to receive the FM S.G. Signal.
- 5) Set the output signal selector of FM STEREO MODULATOR to SUB.

- 6) Adjust the cores of MPX P.C. Board 19 kHz Filter L1(BLK), and 38 kHz Filter L2(WHT) until the distortion factor is minimum. (Refer to Fig. 12)
- 7) Set the output signal selector of FM STEREO MODULATOR to left channel.
- 8) Adjust the MPX Adjustment Volume located on rear panel of the Receiver until the right channel output level is minimum.

7. TUNING METER CENTER ADJUSTMENT

After completing the adjustments outlined in Parts 1 through 4 of this manual, set the FM S.G. Attenuator to non-output condition, and adjust the upper core of FM-AM IF P.C. Board Discriminator Coil T2 shown in Fig. 5 until the tuning indicator needle of tuning meter comes to the center. Then set Receiver dial to 98 MHz, supply a 98 MHz (400 Hz, 100% internal modulation) 66 dB signal from the FM S.G., and fine adjust the lower core of Discriminator Coil T2 for minimum distortion factor.

8. MUTING LEVEL ADJUSTMENT (STEREO INDICATOR SENSITIVITY ADJUSTMENT)

- 1) Connect the various measuring instruments as shown in Fig. 11.
- 2) Set the FM S.G. oscillation frequency to 98 MHz (400 Hz 100% internal modulation) and Attenuator to non-output condition.
- 3) Set receiver dial to 98 MHz.
- 4) Adjust FM-AM IF P.C. Board semi-fixed resistor VR1 68 kΩ so that when the attenuation decreases and the Attenuator scale is at 26 dB, signal output is emitted at both channels.

STEREO SEPARATION ADJ.

L1 (BLK) L2 (WHT)
19KHz F.L. 38KHz F.L.

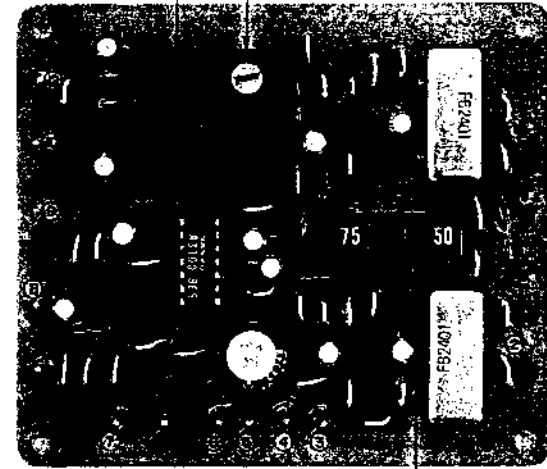

SW 1
DE EMPHASIS SW.

Fig. 12 MPX P.C. BOARD 94-5008

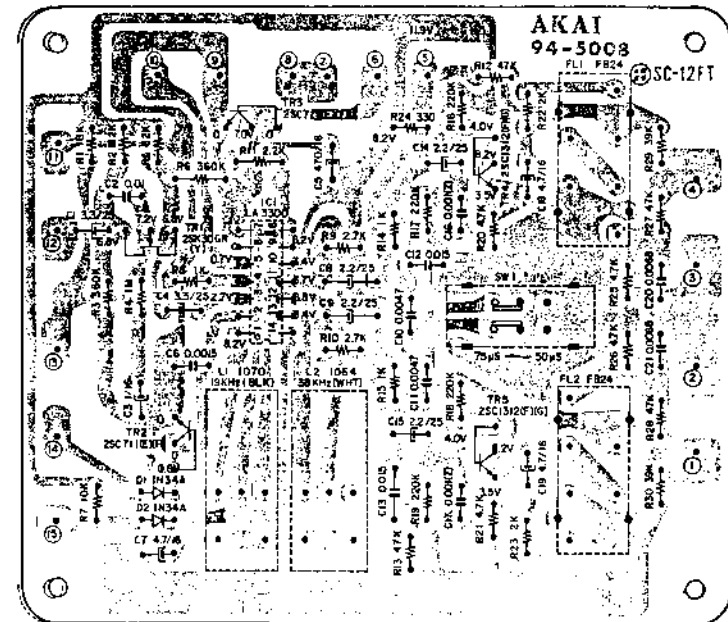
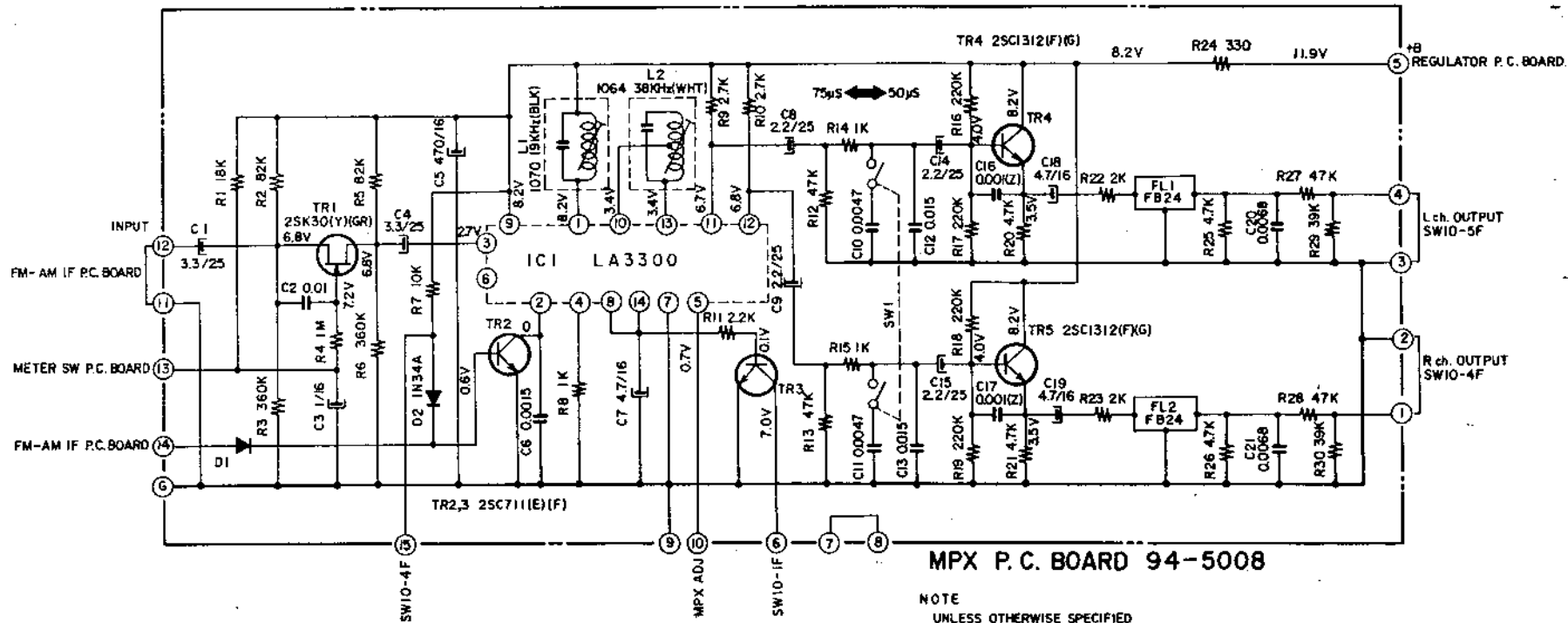

Fig. 13 MPX P.C. BOARD 94-5008 (Rev.)



SCHEMATIC 2

VII. AM TUNER SECTION ADJUSTMENTS

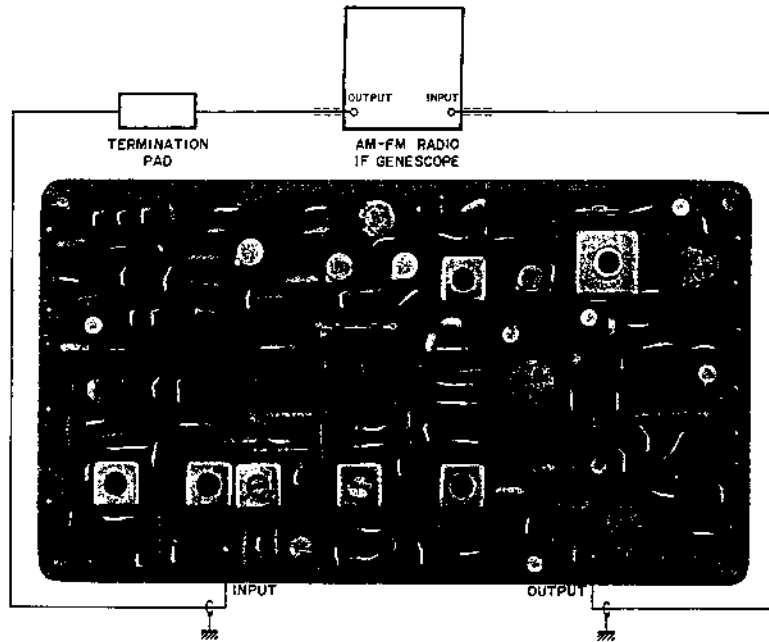

Fig. 14 INSTRUMENT CONNECTIONS

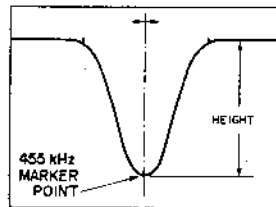

Fig. 15

1. AM IF CIRCUIT ADJUSTMENT

- 1) Connect the AM-FM Radio IF GENESCOPE (hereinafter referred to as GENESCOPE) lead wires to input terminal as well as output terminal of the FM-AM IF P.C. Board as shown in Fig. 14.
- 2) Set GENESCOPE to AM mode and adjust vertical gain. (Refer to Chart 6)
- 3) Set Receiver SELECTOR to AM and set the tuning indicator needle to extreme right end of the dial.

NOTE: A noise element should not enter the single peaked curve shown in Fig. 15.

Vertical Gain	0.3Vp-p to 1 cm
GENESCOPE Output Level	60 dB
Single Peaked Curve Height	4 cm

Chart 6

- 4) Adjust output level of GENESCOPE. (Refer to Chart 6)
- 5) Adjust the cores of FM-AM IF P.C. Board IFT T7(BLK) (refer to Fig. 5) so that the 455 kHz marker point of the single peaked curve displays maximum amplitude as shown in Fig. 15.
- 6) Adjust the cores of FM-AM IF P.C. Board IFT T6(WHT) and T5(YLW) (refer to Fig. 5) so that the left and right rise up characteristics of the single peaked curve shown in Fig. 15 are identical from the center (indicated by the dotted line in the figure).
- 7) In marking this adjustment the single peaked curve marker point will differ according to the rank of the ceramic filter.

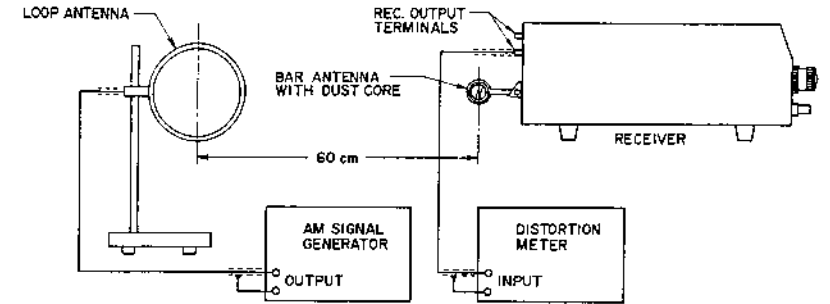
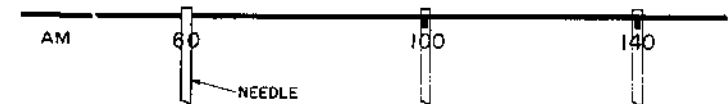

Fig. 16 INSTRUMENT CONNECTIONS



Ref. In making Tracking Adjustments, set dial to following positions.

Fig. 17

AM S.G. Output	60 dB
Core (Low Range)	T4
Trimmer Condenser (High Range)	TC1

Chart 7

Bar Antenna Dust Core (Low Range)	Fig. 16
Trimmer Condenser (High Range)	TC2, TC3
RF Coil (Mid Range)	T3

Chart 8

2. TRACKING ADJUSTMENT

- 1) Connect the various measuring instruments as shown in Fig. 16.
- 2) Set the oscillation frequency of the AM SIGNAL GENERATOR (hereinafter referred to as AM S.G.) to 600 kHz (400 Hz 30% internal modulation) and adjust the AM S.G. Attenuator. (Refer to Chart 7)
- 3) Set Receiver SELECTOR to AM and tuning indicator needle to 600 kHz. (Refer to Fig. 17)
- 4) Adjust the core of FM-AM IF P.C. Board Tracking Adjustment Coil T4(RED) in Fig. 5 until the distortion meter level is maximum and the distortion factor is minimum.
- 5) Set the oscillation frequency of AM S.G. and tuning indicator needle of Receiver to 1,400 kHz. (Refer to Fig. 17)
- 6) Adjust Front End Trimmer Condenser in Fig. 18 until the distortion meter level is maximum and the distortion factor is minimum. (Refer to Chart 7)
- 7) Repeat adjustments outlined in Items 2) through 6) two or three times for minimum tracking error.

3. SENSITIVITY ADJUSTMENT

- 1) Carry out these adjustments after the previously described Tracking Adjustments have been completed.
- 2) Measuring instrument connections are the same as described in Tracking-Adjustments. (Refer to Fig. 16)
- 3) Set the oscillation frequency of the AM S.G. to 600 kHz (400 Hz 30% internal modulation). Set Receiver SELECTOR to AM and the tuning indicator needle to 600 kHz. (Refer to Fig. 17)
- 4) Adjust AM S.G. Attenuator to obtain a 10% distortion factor.
- 5) Adjust dust core of Bar Antenna shown in Fig. 16 until the distortion meter level is maximum and the distortion factor is minimum.
- 6) Set the oscillation frequency of AM S.G. and tuning indicator needle of Receiver to 1,400 kHz. (Refer to Fig. 17)
- 7) Adjust AM S.G. Attenuator to obtain a 10% distortion factor.
- 8) Adjust Front End trimmer condensers in Fig. 18 until the distortion meter level is maximum and the distortion factor is minimum. (Refer to Chart 8)

VIII. TUNING CORD THREADING

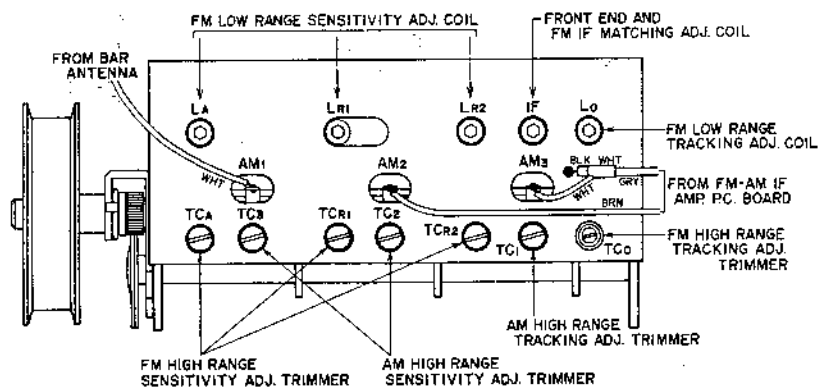

Fig. 18

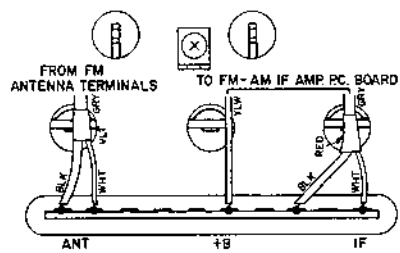

Fig. 19

- 9) Set the oscillation frequency of Am S.G. and tuning indicator needle of Receiver to 1,000 kHz. (Refer to Fig. 17)
- 10) Adjust AM S.G. Attenuator to obtain a 10% distortion factor.
- 11) Adjust the core of FM-AM LF P.C. Board Coil T3(BLU) (refer to Fig. 5) until the distortion meter level is maximum and the distortion factor is minimum.
- 12) Repeat adjustment outlined in Items 3) through 11) at 600 kHz, 1,000 kHz and 1,400 kHz two or three times for highest sensitivity.

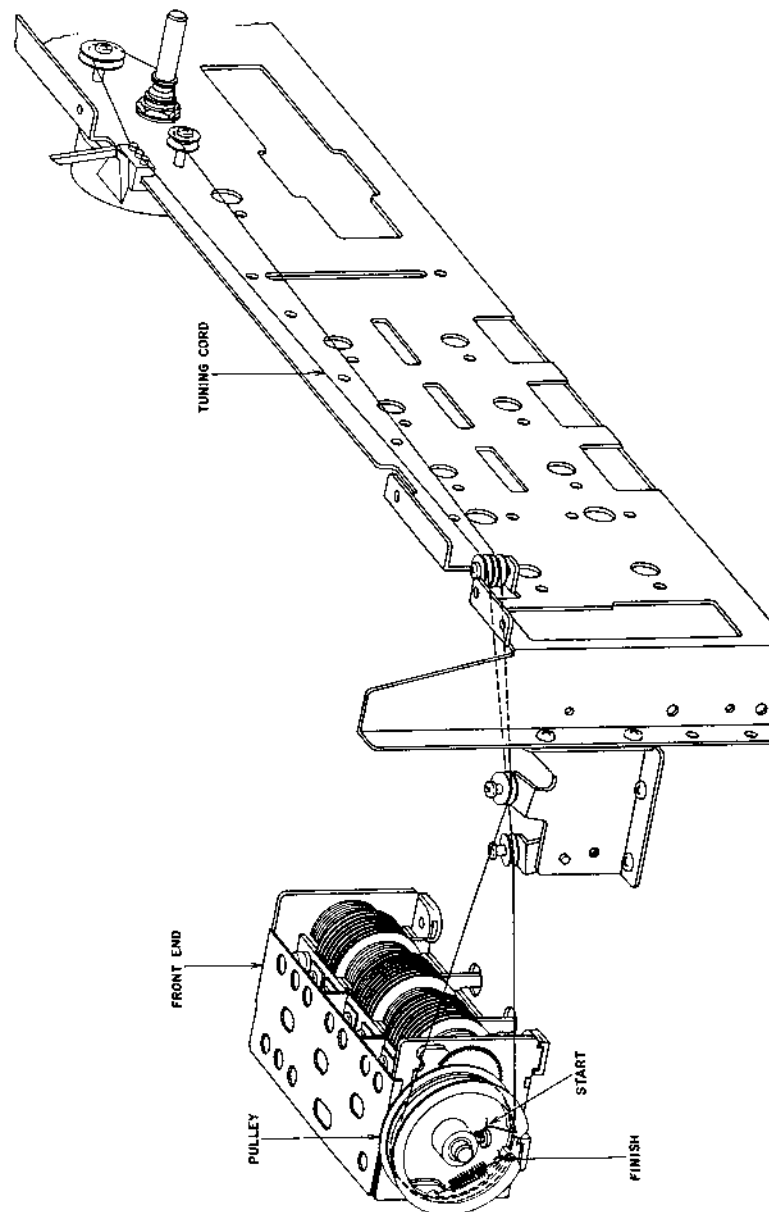

Fig. 20

IX. CD-4 ADJUSTMENTS

1. SERVICING AND ADJUSTING THE CD-4 DEMODULATOR

There are two ways to provide the signals for testing a CD-4 demodulator: either using a purely electrical signal generator or using a test record. When testing the measurements will be influenced by the mechanical vibration system of the cartridge stylus assembly, this will reduce the accuracy of your measurements. To precisely measure the performance of a demodulator you must use a standard signal source such as an SCA signal generator or an audio signal generator. When carrying out repairs or replacements or when checking the demodulator's characteristics roughly, it will be convenient to use a test record.

- 1) Adjusting Instruments
 - a) Audio oscillator: 20 Hz-50 kHz
 - b) SCA signal generator: Meguro's MSG212A, etc. (replaceable with a test record)
 - c) Oscilloscope: input impedance of more than 500 k Ω ; frequency band width of wider than DC-100 kHz.
 - d) AC voltmeter: input impedance of 1 M Ω ; -60 dB readable (AC millivoltmeter)
 - e) Attenuator: frequencies, higher than 100 kHz
 - f) Test record: RG1256/1257

2) Specifications of Test Record

RG1256 (33-1/3 rpm)	
Band 1 CH1 Warble tone	Warble tone of each channel is used for adjusting and checking channel crosstalk.
Band 2 CH2 Warble tone	
Band 3 CH3 Warble tone	
Band 4 CH4 Warble tone	
Band 5 Channel announcement	Each channel announcement and 700 Hz signals are repeated in the order CH1 to CH4 to identify the channel.
Band 6 CH1 + CH3 700 Hz	FRONT centering signal
Band 7 CH2 + CH4 700 Hz	REAR centering signal
Band 8 Difference signal	700 Hz reference signal (0 VU) Only the difference signal is in-phase for right and left channels, and used for setting the input level into the ANRS expander.
Band 9 30 kHz unmodulated carrier	Only the carrier is cut on the innermost grooves on the record and used for checking the operation of the demodulating circuit.
RG1257 (33-1/3 rpm)	
Band 1 CH + CH3 Frequency signals spot	Signals for checking the rough frequency characteristic. Spot frequencies are as follows: 1k, Break, 12k, 10k, 8k, 6k, 4k, 2k, Break, 1k, 700 Hz, 400Hz, 200 Hz, Break, 100 Hz, 70 Hz, 50 Hz and 30 Hz
Band 2 CH2 + CH4 Frequency signals spot	
Band 3 Difference signal	700 Hz reference signal (0 VU) Same as RG1256 Band 8
Band 4 Difference signal 400 Hz 4 kHz modulation (L+R)	Signals for testing the 30 kHz carrier level.
Band 5 Difference signal 400 Hz 8 kHz modulation (L+R)	

Measuring point		Representative measured value (0 dB=0.775V)			
(L)	(R)	100 Hz	1 kHz	10 Hz	30 kHz
TP109	TP110	+6 dBs	-6 dBs	-7 dBs	-7 dBs

Chart 9

Cartridge	Measuring point		Representative measured value (0 dB=0.775V)				Remarks
	(L)	(R)	100 Hz	1 kHz	10 kHz	30 kHz	
4MD-10X	TP111	TP112	-40 dBs	-40 dBs	-28 dBs		
	TP109	TP110				-20 dBs	Large error
4MD-20X	TP111	TP112	-38 dBs	-38 dBs	-26 dBs		
	TP109	TP110				22 dBs	Large error

Chart 10

3) Checking 1/2 Equalizer Characteristics

Characteristics of the 1/2 equalizer can be checked with either an audio oscillator or test record. The audio oscillator is recommended for a precise testing.

- a) Checking with Audio Oscillator
 - Signal application point, PHONO INPUT
 - Signal application level -40 dBs
- b) Checking with Test Record
 - Test Record: RG1257 Band 1 or Band 2 (100, 1k, 10 kHz) and RG1256 Band 9 (30 kHz)
 - Cartridge: 4MD-10X or 4MD-20X

- NOTE: 1. When the test record method is used, the measured values vary to some extent depending upon the cartridge used. Especially the errors in measured values at 10 kHz and 30 kHz will be large.
2. If the measured values are entirely different from the above listed representative values, there is probably something wrong with the transistors or ICs, or disconnecting or shorting of the wires. If the measured values are different at specific frequencies, the NF circuit is suspect.

4) Checking the Characteristics of the 2/2 Equalizer and Operation Circuit

- a) Checking with Audio Oscillator
 - Signal application level, -40 dBs.
- b) Checking with Test Record
 - When this method is used the 1/2 equalizer must operate normally. Therefore the equalizer must be checked in advance according to the method described in 3). The same test records are used as in 3)-b).

NOTE: 1. Since the measured values vary depending upon the cartridge used, the variation at 100 Hz and 10 kHz compared to that at 1 kHz must be checked.

2. The separation tuning VR refers to the "CD-4 Adjust" screws on the front panel of the receiver.

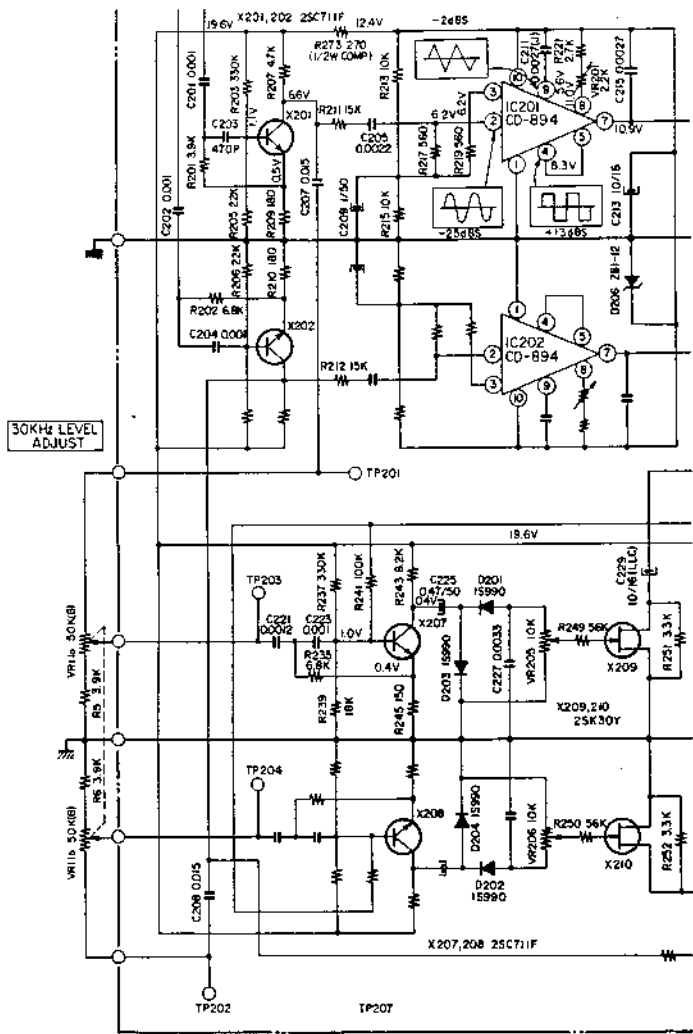

SCHMATIC 3

Signal application point		Measuring point		Representative measured value (0 dB=0.775V)			Remarks
(L)	(R)	(L)	(R)	100 Hz	1 kHz	10 kHz	
TP111	TP112	TP115 (C111 OUT)	TP116 (CH3 OUT)	-16 dBs	-17 dBs	-30 dBs	The separation tuning VR is set to max.

Chart 11

Cartridge	Measuring point		Representative measured value (0 dB=0.775V)			Remarks
	(L)	(R)	100 Hz	1 kHz	10 kHz	
4MD-10X	TP115	TP116	-14 dBs	-14 dBs	-14 dBs	The separation tuning VR is set to max.
4MD-20X			-12 dBs	-12 dBs	-12 dBs	

Chart 12

5) Checking the Demodulation Circuit

The demodulation circuit is checked by the wave form developed when the 30 kHz signal (Audio oscillator or test record RG1256 Band 9) is applied.

a) Adjusting the VCO

The various wave forms shown in SCHEMATIC-3 are generated when a -50 dBs, 30 kHz signal is applied to the PHONO terminal. The wave forms at various sections are almost the same when test record RG1256 Band 9 is played using cartridge 4MD-10X or 4MD-20X.

The free-running frequency of PLL IC CD-894 must be adjusted correctly to 30 kHz. When the IC and its peripheral circuit is repaired, it is necessary that the free-running frequency be readjusted correctly. The adjustment is done in accordance with the so-called zero beat method. An accurate 30 kHz signal (Audio oscillator or test record RG1256 Band 9) is applied to the PHONO terminal so that the beat between this 30 kHz signal and the free-running frequency can be detected and reduced to zero. When the input is large, the locking range of the PLL is wide so that adjustment becomes impossible.

Therefore the PHONO input is attenuated to -110 dBs or so. Output is possible at any stage after the LPF(F201), but it will be easier if the adjustment is done while listening to the beats through an ear-phone (Fig. 21). In this case it is necessary that the muting circuit be kept OFF. (See Note in 1-6))

When adjustment is done using test records, attenuating the input is complicated. For example, when test record Band 9 is played by using a 2 channel stylus, the 30 kHz signal will be attenuated and the adjustment can be achieved easily by making a gap between the stylus and the cartridge body as shown in Fig. 22, by not inserting the stylus fully into the cartridge body. In this case the muting circuit must also be kept OFF.

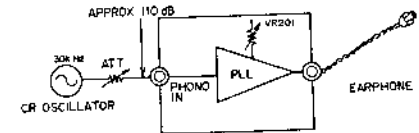

Fig. 21

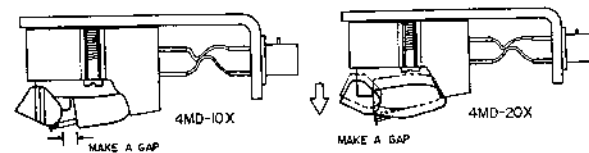

Fig. 22

NOTE: 1. During the adjustment of the VCO, it is better to apply signals to both channels simultaneously, but it is also necessary to identify whether beats are developed between the input signal and the leakage from the VCO of the opposite channel, or between the input signal and the input 30 kHz signal. This identification can be made by examining the variation of the input signal when the input frequency is varied slightly.



Fig. 23

2. When the adjustment is made using test records, the gap between the stylus and the cartridge body must be determined empirically. In this case it is necessary that the gap be increased gradually to check whether beats are generated or not, subject to the wow & flutter of the turntable.

3. When VCO is not adjusted, beats will be heard when the stylus is placed on or taken off the record surface. Besides, beats are likely to be heard when the record is worn and the carrier level has diminished.

b) 30 kHz Level Control (Lock Range Control)

The 30 kHz level control adjustment entails setting variable resistor VR11 for user servicing and presetting variable resistor VR205 to absorb unevenness of the circuit from unit to unit. To precisely adjust preset VR205, it is necessary to use an FM modulator. A simple adjusting method using cartridge 4MD-10X or 4MD-20X and record RG1257 Bands 4,5 is explained; First turn the 30 kHz level (on the rear of the set) fully counter-clockwise.

Then turn it by six clicks in clockwise direction. While playing RG1257 Band 5 turn preset variable resistor (VR205) until the sound changes suddenly. At this moment the output wave form becomes as shown in Fig. 23 having one or two projections above the sine wave. At this time make sure of the following two points:

- i) Playing Band 5, the projections disappear when the variable resistor is turned counter-clockwise by one graduated scale.
- ii) On Band 4, no projections appear when the variable resistor has been turned by 6 clicks.

NOTE: 1. 30 kHz Level Adjusting Signal

In order to establish a correct lock range for the cartridge being used, a difference signal of 400 Hz with ± 4 kHz deviation is recorded on the adjustment record supplied with the Demodulator. To get high fidelity sound from CD-4 records, a lock range of ± 10 kHz is sufficient. This frequency deviation of ± 10 kHz is, however, not suitable for the signal adjustment because it leads to a high demodulated output.

Therefore, the test signal uses a deviation of ± 4 kHz and has a carrier level 4 dB lower than that of the regular record. For example, with a cartridge which picks up a carrier of -50 dBs from an ordinary CD-4 record, if the carrier level is set so as to obtain a lock range of ± 4 kHz when a carrier of -54 dBs is applied, the lock range when playing ordinary CD-4 records will be ± 10 kHz, as understood from Fig. 24.

2. When the reproduced wave forms have the shape shown in Fig. 25 (a) irrespective of the position of the variable resistor, it shows that the FET is not controlled properly and something is wrong in the VR11, X207, D201, D202, VR205 or X209 circuit.

3. When the reproduced wave form becomes a sine wave (Fig. 25 (b)) irrespective of the volume position, FET X209 may be regarded as being open.

4. Since the rectangular waves at PLL IC pin (4) and pin (5) and the triangle wave at pin (9) are oscillation signals from VCO, they are the unmodulated 30 kHz signals when no input is applied. When these waves are not formed, the IC may be defective. However, the wave forms will be out of shape if the measuring system has a large capacity.

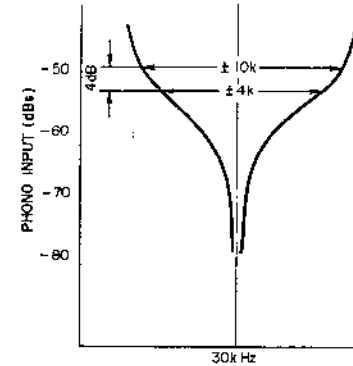

Fig. 24

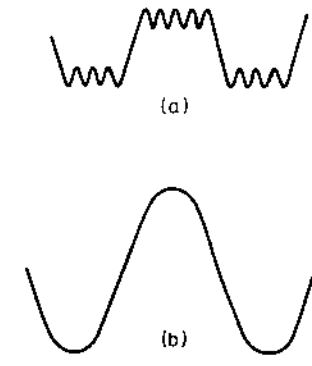

Fig. 25

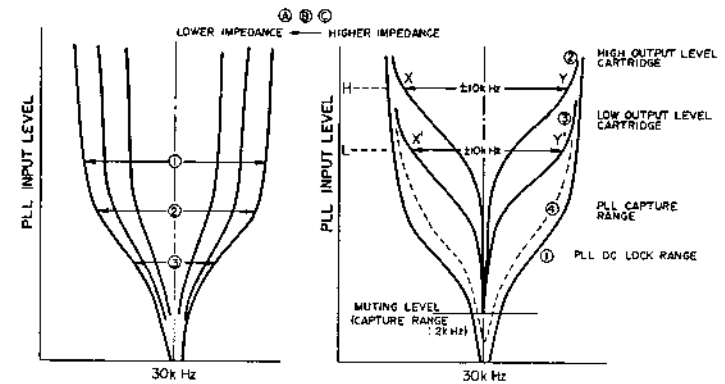
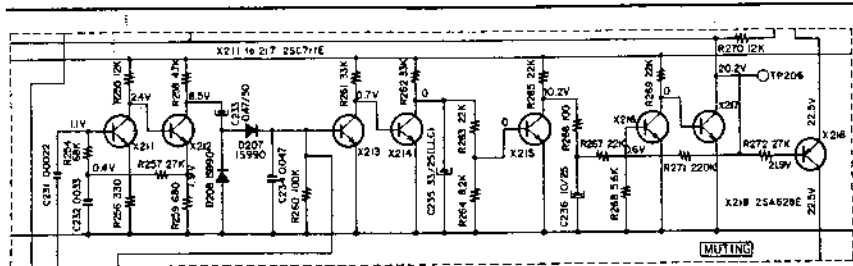

Fig. 26

5. Actual Circuit

The operation of the difference signal demodulation circuit will be explained taking the left channel of the CD-4 demodulator as an example (see attached circuit diagram). The 30 kHz carrier modulated by the difference signal is transmitted to X201 after having been amplified by the 1/2 equalizer. The base circuit of X201 incorporates an active high pass filter with 20 kHz cut-off which removes the sum signal at 12 dB/oct. The sum signal component which was left unremoved here can be removed by the highly selective PLL which was designed so as to be locked only to the carrier component. There are attenuators R211 (=15 k Ω) and R217 (=560 Ω) at the PLL input. The gain between PHONO input and PLL was designed to be 25 dB.

X207 is a control signal amplifier stage and has, at its input, a variable resistor (VR11) for 30 kHz level adjustment and a high pass filter. VR11 is used to obtain one of the curves (2) or (3) in Fig. 26 according to the cartridge used. The control signal of the FET forms a negative voltage which is rectified after amplification by X207. The source-drain resistance R_{DS} becomes open at a gate voltage of -1.5 V. Starting at this voltage, the negative voltage becomes smaller as the input signal decreases.



SCHMATIC 4

Signal application point		Measuring point		Representative measured value			Remarks
(L)	(R)	(L)	(R)	100 Hz	1 kHz	10 kHz	
TP301	TP302	TP303	TP304	-0.5 dBs	-4.5 dBs	-22.0 dBs	

NOTE: The frequency characteristic of the PM/FM equalizer is as shown in Fig. 27

Chart 13

Input signal	Measuring point	Adjusting point	Adjusting method
Record used: RG1256	L: CP323	VR303	The level at the measuring point is adjusted to -15 dBs.
Band 8	R: CP324	VR304	
	L: TP303	VR203	
Cartridge used:	R: TP304	VR204	
	L: 16	R547	
	R: 18	R548	

Chart 14

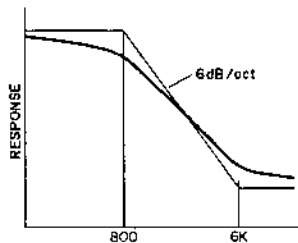

Fig. 27

Signal application point	Input level measuring point	Output level measuring point
L: TP301	TP303	TP117
R: TP302	TP304	TP118

Chart 15

Frequency of the input signal	Input level	Output level
High frequency band (15 kHz)	-15 dBs	-14 dBs±2 dB
	-25 dBs	-29 dBs±1 dB
	-40 dBs	-54 dBs±2 dB
Medium frequency band (600 Hz)	-15 dBs	-14 dBs±2 dB
	-25 dBs	-30 dBs±1 dB
	-35 dBs	-46 dBs±2 dB

Chart 16

6) Checking the Muting Circuit

SCHMATIC-4 shows the waveform and voltage of the CD-4 muting circuit. The figure in () indicates the voltage when the 30 kHz carrier is applied; and the voltage in () shows the one when no 30 kHz carrier is applied. The AC wave forms and levels given are the ones when the 30 kHz signal at -50 dBs is applied to PHONO IN.

NOTE: 1. The muting circuit will not operate without the carrier component. When it is required to keep the muting circuit OFF during service checking of the demodulation section, TP206 should be grounded.
2. When the muting circuit is OFF, the input level is -85 dBs±5 dB at the PHONO input terminals.

7) Checking the PM/FM Equalizer

The PM/FM equalizer is comprised of an emitter-follower. Checking is done using an Audio oscillator.

Signal application level: 0 dBs

8) Adjusting the Demodulated Output

The ANRS (Automatic Noise Reduction System) in the CD-4 system is constructed so that a complementary relationship exists between the recording system and the playback system and so that a predetermined signal level must be applied to the expander section to obtain a predetermined modulated signal. This predetermined signal level or ANRS expander input at 0 VU in the recording system is set at -15 dBs. The adjustment is carried out playing test record RG1256 Band 8.

9) Checking and Adjusting the ANRS Expander

Checking and adjusting the ANRS expander is carried out by using an audio oscillator. Make sure that the separation tuning variable resistors are set to minimum. Input application and measuring point are as listed in the following table.

a) Checking and Adjusting the CD-4 Demodulator
Properly adjusted CD-4 demodulator has following levels:

Readjustment if necessary is carried out in the following sequence:

- i) VR301 (L ch) and VR302 (R ch) are turned counter-clockwise and clockwise, respectively prior to adjustment.
- ii) When the frequency of the input signal is 15 kHz and the input level is set to -25 dBs at the measuring point, VR303 (L ch) and VR304 (R ch) are adjusted so that the output becomes -29 dBs.
- iii) When the input levels are set to -15 dBs and -40 dBs without changing the input signal frequency, make sure that the output levels become as listed in the above table.
- iv) When the frequency of the input signal is 600 Hz and the input level is set to -25 dBs at the measuring point, VR301 (L ch) and VR302 (R ch) are adjusted so that the output level becomes -30 dBs.
- v) When the input levels are set to -15 dBs and -35 dBs without changing the input signal frequency, make sure that the output levels become as listed in the above table.

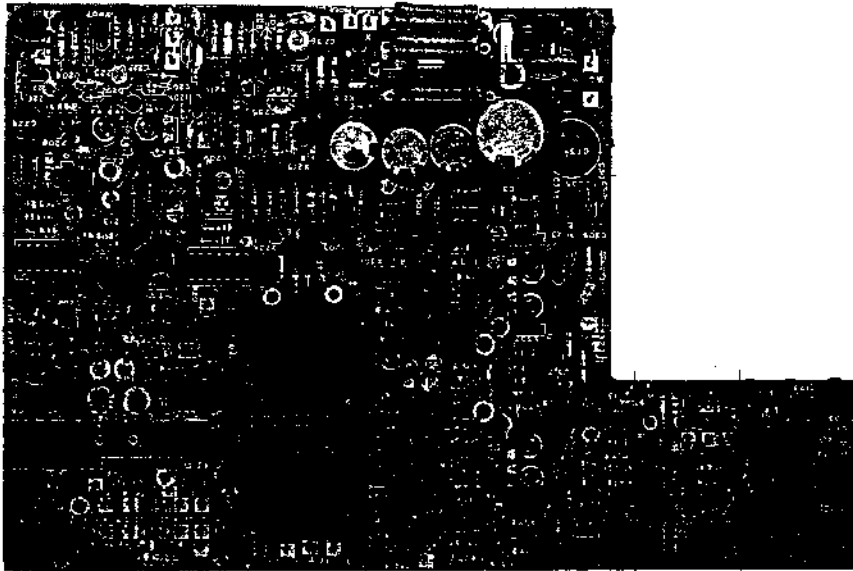

Fig. 28

2. SERVICE POINTS FOR THE CD-4 PLAYBACK SYSTEM

Malfunction in the CD-4 playback system can be caused by a wide variety of factors such as trouble with the record, cartridge, stylus, player and demodulator, the connections between these components, and the mishandling of the playback system. Many troubles caused by different factors will present almost the same symptoms. Malfunction can be traced and corrected conveniently by searching for first large, then small problems. Here, some of the major problems which are liable to occur are described.

1) Noise

a) Dust

Due to the improved compatibility of the demodulator, noise is largely decreased. However, CD-4 records are more easily affected by dust than ordinary stereo records. When the stylus tracks at a frequency as high as 30 kHz, a system which can accurately track high frequencies is required.

Therefore even fine dust should be eliminated as far as possible.

Dust adheres not only to the record surface but also to the stylus. During tracking along the groove, the stylus collects dust from the record surface and removes record material which may be deposited on the stylus. The record material deposited in this manner will be melted by the heat generated by the friction between the stylus and record surface. Cleaning fluids and drops of water will soften the record material and cause the dust to coagulate, so that they are both useless and harmful.

b) Requirements of the cartridge

It is not easy to pick up the 30 kHz signals from the record surface with a mechanical vibrating system. The high frequency characteristics of a cartridge is determined almost entirely by the configuration and structure of stylus used, so that a 2 ch stylus is not sufficient even if the cartridge body is suitable for CD-4.

Make sure the cartridge and stylus are both specified for CD-4 use. (With the highly compatible CD-4 demodulator, playback is sometimes possible using a 2 ch cartridge.)

The 2 ch cartridge is designed to cover only the audible range so that this type of cartridge cannot always be used in CD-4 playback. Even if playback is possible according to specifications, many cartridges are magnetized in the wrong polarity and are therefore unsuitable. The polarity of magnetization is no problem in playing back stereo records, but it must be correct for playing back CD-4 records. If the polarity of magnetization is wrong, the front and rear channels will be reversed in playback.

c) Requirements in the player

It is important that the 30 kHz signal picked up by the cartridge be sent to the demodulator with as small a loss as possible. The signal cord from the player plays an important role in this. The optimum load of a CD-4 cartridge is 100 k Ω , 100 PF and the input capacity of the demodulator is in the order of about 50 PF, so that the optimum condition is that the signal cord should have a capacity less than 50 PF. A capacity of 50 PF is provided by 1.2m of 40 PF/m low capacitance cable.

Care must be taken in such cases as when a player switching box is used in a store.

d) Noise from the demodulator

Noise is transmitted together with the sum and difference signals. The noise relating to the sum signal and the noise relating to the difference signal are distinguished from each other roughly as follows:

Noise associated with sum signal:

Noise which is generated at the 2CH position.

Noise which disappears when the separation variable resistor is set to minimum.

Noise associated with difference signal:

Noise which is generated even after the separation variable resistance has been set to minimum.

The noise associated with the signal includes comparatively well known transistor noise and other external noises. The noise associated with the difference signal can be distinguished between those appearing before demodulation and those appearing after demodulation depending on whether they are heard only when the muting is turned ON or when it is turned ON and OFF. When no record is played back, noise is heard, it may be because of noise from the muting circuit.

e) Noise generated in playing back stereo records
As CD-4 incorporates an auto-muting circuit, little noise will be generated even when a stereo record is played back in the 4CH-AUTO and CD-4 positions. However, there are some exceptions. They are stereo records with an unnecessary super-sonic component engraved (non-distortion cutting) on the surface, which have a high frequency oscillator in the cutting process. With such records, set the demodulator switching knob to "2 ch" before playback.

2) Separation

Separation is so sensitive that the effectiveness of a CD-4 playback system is mainly determined by its separation. If the sum signal and difference signal differ from each other by 1 dB immediately before they enter the operation circuit in the demodulator, channel separation will be less than 20 dB.

If the difference in phase is 10°, separation will be degraded additionally by 5-6 dB. Level may be controlled in the medium frequency range by adjusting the separation, but the disturbance in high frequency characteristics due to the cartridge used cannot be compensated for. Phase is influenced by the frequency characteristics in the audible frequency range of the cartridge used and also by the difference signal transmission system. It is not uncommon that the shift of phase results from mechanical factors such as inclination of the cartridge, stylus pressure, etc. The largest cause of separation degradation in the demodulator is frequency characteristics at various points. Separation degradation is prevented only by checking and adjusting the various of the demodulator carefully.

When no separation can be achieved at all, this shows that either the sum signal or difference signal is not present, so that this must be distinguished clearly from the case of poor separation. It is necessary that the separation of a demodulator should be checked when the characteristics of the various parts are correct. If it is found that the characteristics of the various portions are correct, the cause of the poor separation must lie elsewhere.

3) Beats

The CD-4 high compatibility demodulator incorporates a 30 kHz oscillator. During normal operation, the oscillation is synchronized with the 30 kHz input signal. However, when the input level is low and there is a frequency difference between the sum and difference signals, beats will be generated. For example, if the speed of the player differs by 10%, the oscillation frequency of normal 30 kHz will become either 27 kHz or 33 kHz and beats will be generated. When the oscillation frequency of PLL is shifted, the same result will be obtained.

X. CD-4 P.C. BOARD OPERATION

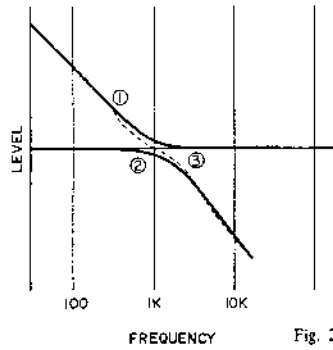

Fig. 29

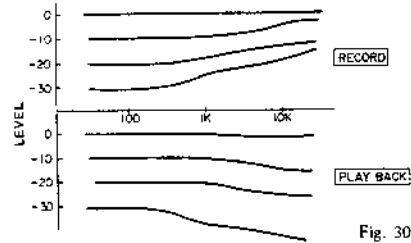

Fig. 30

To understand CD-4 demodulator operation, please refer to the block diagram. The parts numbers used in the following explanation, except for the mute circuit, are left channel only.

The pick-up cartridge output signal which is introduced to the PHONO input terminal enters IC101 of the 1/2 Equalizer (turn-over) section. The frequency response of this 1/2 Equalizer is as shown by curve (1) (1 kHz gain 34 dB) of the graph in Fig. 29. The signal amplified at this Equalizer is the less than 15 kHz sum signal (FL+RL) and the 20 to 45 kHz difference signal (FL-RL).

The sum signal passes low pass filter (F101) and is supplied to IC103 of the next stage 2/2 Equalizer (roll-off) section. The frequency response of this 2/2 Equalizer is as shown by curve (2) of the graph shown in Fig. 29.

Accordingly, the frequency response of the sum signal from the 2/2 Equalizer becomes as shown by curve (3) of the graph in Fig. 29 (passes RIAA curve) and flat sum signal frequency response is obtained.

The difference signal passes the high pass filter which is comprised of X201 and is supplied to the demodulator which is comprised of the next stage PLL IC (IC201). X201 output is supplied to lock range control and controls the discriminator width of PLL IC, the right channel X202 output signal is supplied to the mute circuit, and the difference signal demodulated output is taken from pin (7) of PLL IC.

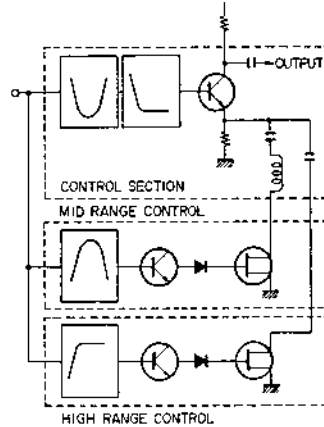

Fig. 31

The demodulated signal (which was demodulated at PLL IC) is amplified at X203, passes muting gate X205 and at low pass filter F201, except for the 30 kHz carrier element, becomes the audio signal of the difference signal system.

The carrier element taken from X202 is supplied to the mute circuit. Consequently, when there is no carrier (no difference signal) the muting gate (X205) is turned ON, and there is no output signal emitted from X205 output side.

In cutting a CD-4 record because PM-FM is supplemented for frequency compensation, it is necessary to revert to this condition at playback time. The PM-FM equalizer is comprised of the CR network in the X301 circuit and the PM-FM equalizer output is supplied to the next stage ANRS. The ANRS is for the purpose of reducing noise generated by mechanical change of the CD-4 record. (cutter → record → pick up cartridge)

Such noise is played back at a certain level as background noise. Consequently, if the music source is at a low level, an unpleasant noise is heard. To reduce this disadvantageous noise, the cutting volume level of mid-range and high range frequencies are boosted at cutting time, and then at playback time, these previously boosted mid range and high range levels are reduced. (Refer to Fig. 30)

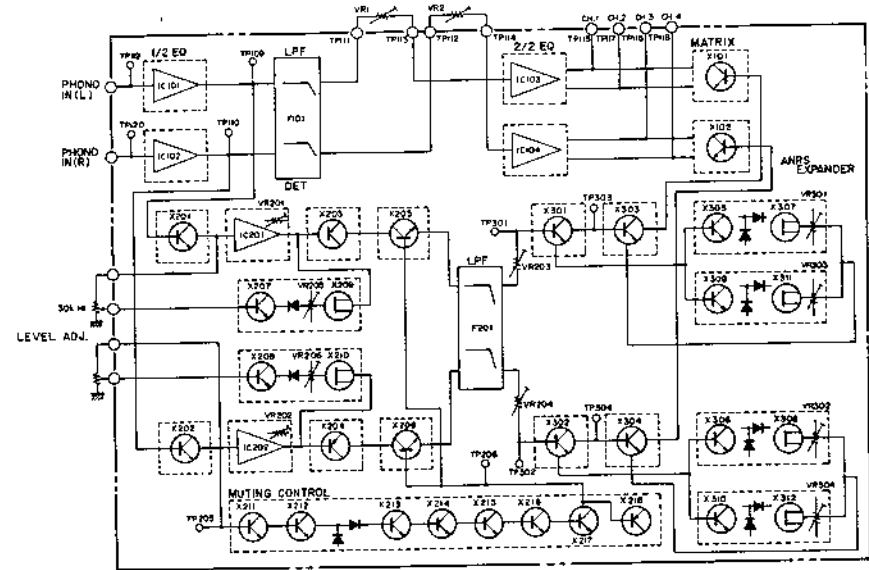

CD-4 BLOCK DIAGRAM 1

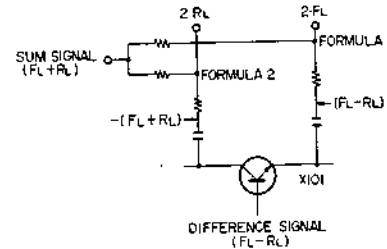

Fig. 32

As shown in Fig. 31, the playback system ANRS expander circuit is comprised of 3 different sections. The base side of the control section is equipped with mid range and high range cut filters which change resistance R_{DS} between the drain and source of the mid range frequency control section and the resistance R_{DS} between the drain and source of the high range frequency control section. Consequently, at mid range and high range frequencies, the signals pass the network and the amplitude of control section X303 is changed. Because X303 amplitude is changed by the input signal level, the ANRS supplement is also according to the input signal level. The difference signal from the record which is detected by the pick up cartridge passes this ANRS expander and the difference signal frequency response becomes flat.

This difference signal output together with the sum signal is supplied to the matrix circuit. (Refer to Fig. 32)

Difference signal (FL-RL) is supplied to the base of X101, the collector output is phase inverted (FL-RL) and an in-phase (FL-RL) signal is emitted at the emitter output.

Therefore the formula for difference signal and sum signal is as follows:

$$\begin{aligned} (FL+RL)+(FL-RL) &= 2 \cdot FL \dots (1) \\ (FL+RL)-(FL-RL) &= 2 \cdot RL \dots (2) \end{aligned}$$

2·FL and 2·RL are produced by the above formulas (1) and (2).

For optimum separation, it is necessary for the difference signal and sum signal levels to display conformity. However the sum signal system output level differs depending upon pick up cartridge type, etc.

Therefore, in order to obtain sum signal and difference signal level conformity, a volume control is installed between the 1/2 equalizer and 2/2 equalizer to adjust the level of sum signal to that of the difference signal.

XI. SQ & RM OPERATING PRINCIPALS

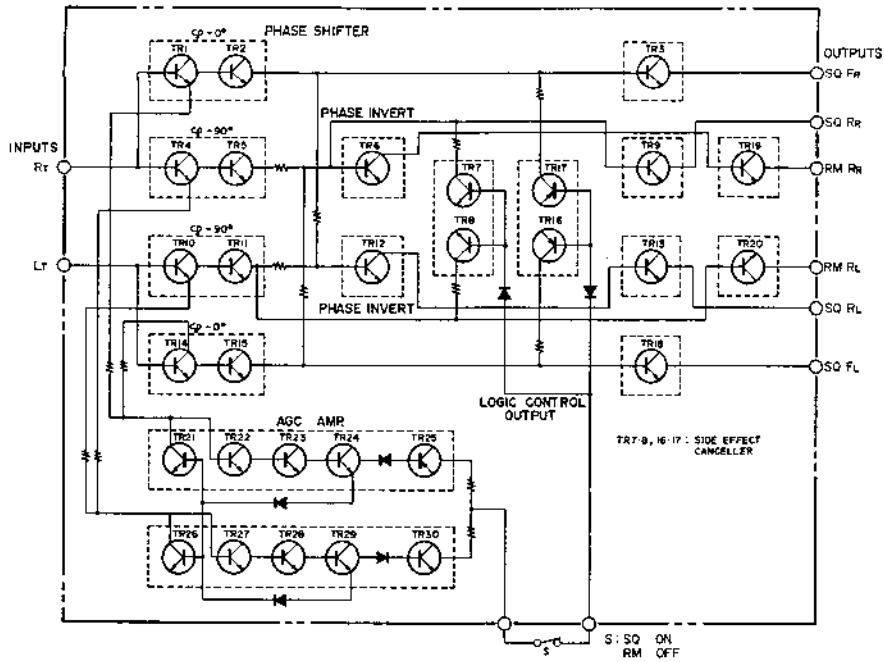

SQ & RM BLOCK DIAGRAM 2

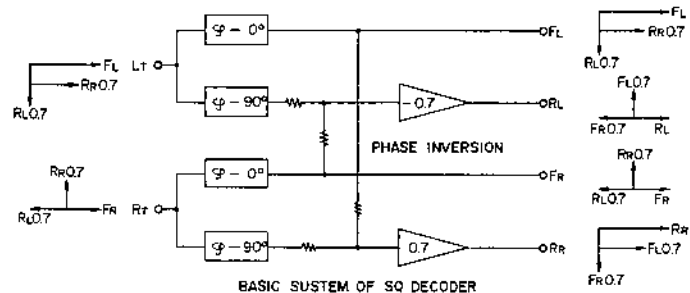

Fig. 33

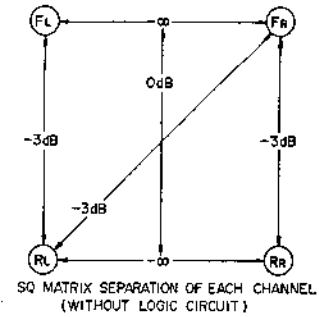

Fig. 34

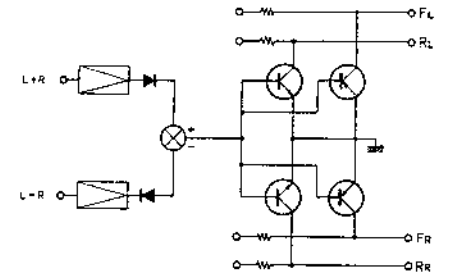
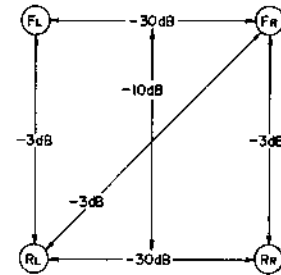

Fig. 35



IMPROVED SEPARATION BY MEANS OF FRONT/BACK LOGIC

Fig. 36 FRONT-BACK LOGIC

$|L+R| > |L-R| \dots$ Rear Damping
 $|L+R| < |L-R| \dots$ Front Damping
 $|L+R| \approx |L-R| \dots$ Not Operating

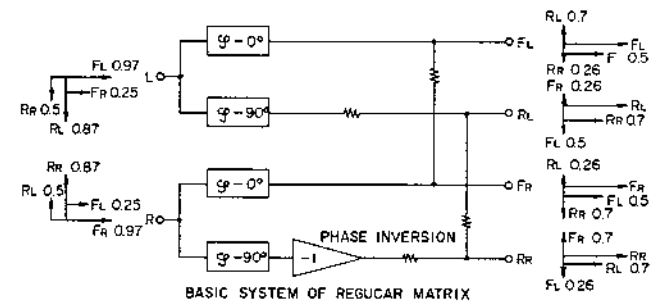

Fig. 37

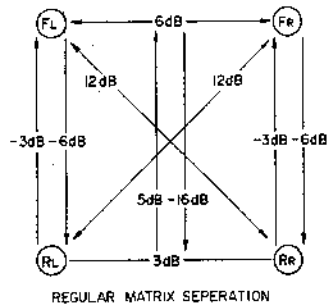

Fig. 38

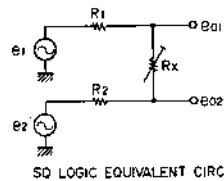

Fig. 39

Front Back Logic Operating Principles

Front left/right separation can be attained to infinite (∞), but when the sound image is centered on front or rear, front/rear separation cannot be attained. Consequently, crosstalk including a phase inverted element is forcibly applied to L_T, R_T output, and this phase inverted element is cancelled.

If we figure degree of attenuation (k_1, k_2) based on Fig. 39.

$$k_1 = \frac{e_{01}}{e_1} = \frac{R_2 + R_x}{R_1 + R_2 + R_x} + \frac{R_1}{R_1 + R_2 + R_x} \cdot \frac{e_2}{e_1}$$

$$k_2 = \frac{e_{02}}{e_2} = \frac{R_1 + R_x}{R_1 + R_2 + R_x} + \frac{R_2}{R_1 + R_2 + R_x} \cdot \frac{e_1}{e_2}$$

However, R_x is the variable resistor.

Assuming that the logic circuit is ON, $e_1 = -e_2$ is provided, and the variable resistor value is R_{x0} , the above formula becomes:

$$k_1 = \frac{R_2 + R_{x0} - R_1}{R_1 + R_2 + R_{x0}} \quad k_2 = \frac{R_1 + R_{x0} - R_2}{R_1 + R_2 + R_{x0}}$$

By providing each resistance value, the desired logic attenuation volume (for instance 10 dB attenuation) can be obtained. Whether the logic circuit operation is provided to the F_L, F_R front channels or R_L, R_R rear channels is determined by which of the components (in-phase component or inverted phase component) included in L_T, R_T is the larger. In other words, if the in-phase component is the larger, the rear channels are attenuated (damped) by the logic circuit and if the inverted phase component is the larger, the front channels are attenuated. Therefore, operation is as per the following three formulas:

in case of $|L_T + R_T| > |L_T - R_T|$ damping is applied to rear direction channels.

In case of $|L_T + R_T| < |L_T - R_T|$ damping is applied to front direction channels.

In case of $|L_T + R_T| = |L_T - R_T|$ no operation exists.

XII. POWER AMPLIFIER ADJUSTMENTS

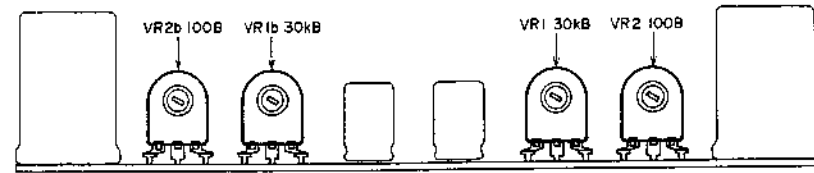

Fig. 40

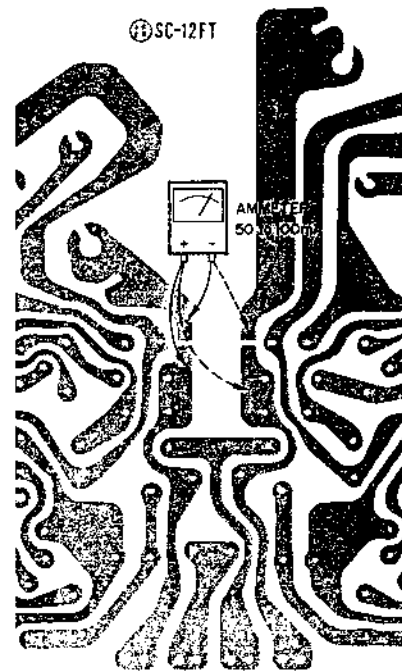

Fig. 41

1. POWER AMP. NON-INPUT CURRENT ADJUSTMENT (Refer to Figs. 41,42)

- 1) As shown in Fig. 43, remove solder from soldering point of Power Amp. P.C. Board.
- 2) Connect a 50 to 100 mA scale ampere meter to the place from which the solder was removed in Item 1-1). (Fig. 41)
- 3) Adjust semi-fixed resistors VR2 100B(Left) and VR2b 100B(Right) of Power Amp. P.C. Board shown in Fig. 40 to obtain a 40 mA ampere meter indication on both the left and right channels.

2. VOLTAGE ADJUSTMENT BETWEEN POWER TRANSISTORS C-E

- 1) Connect voltage meter to collector of Power Amp. P.C. Board Power Transistors TR6, TR6b shown in Fig. 42.
- 2) Adjust semi-fixed resistors VR1 30 kB(Left) and VR1b 30 kB(Right) of Power Amp. P.C. Board shown in Fig. 40 to obtain half the value of the power source voltage.

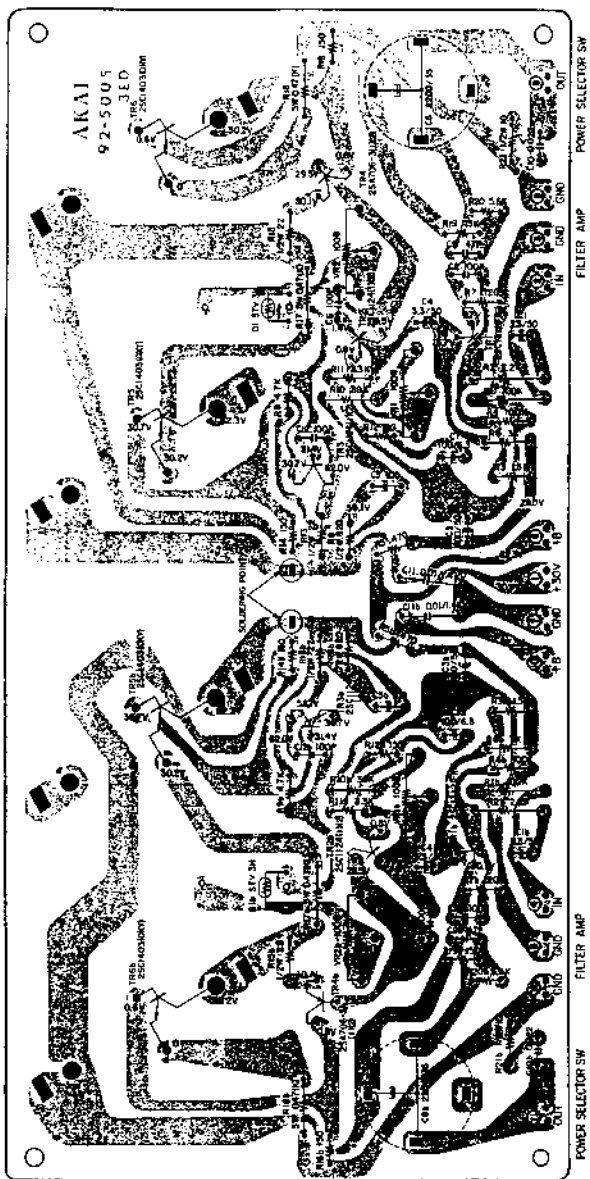

Fig. 43 POWER AMP. P.C. BOARD 92-5005 (Reverse)

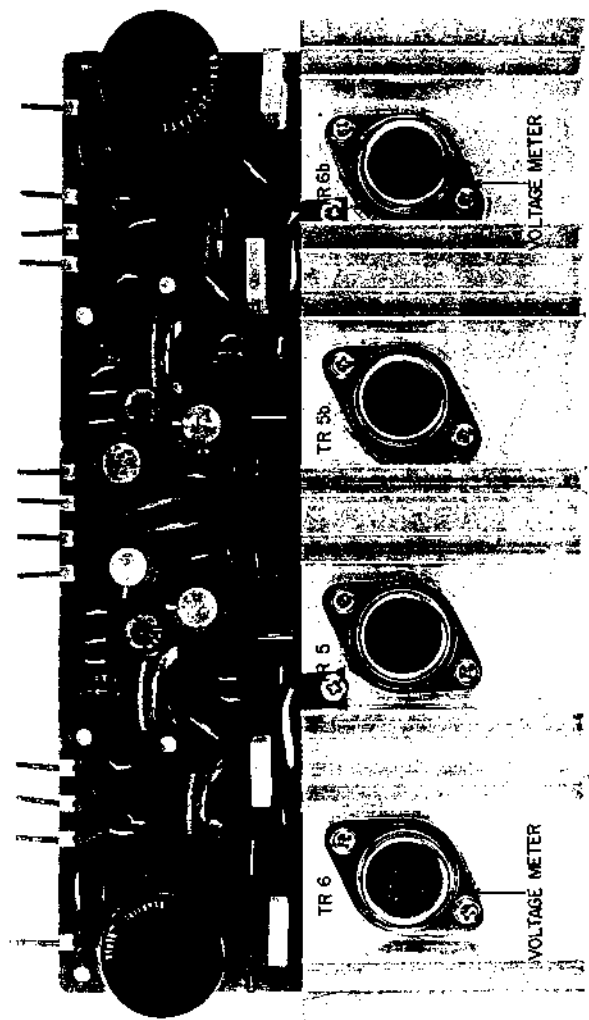
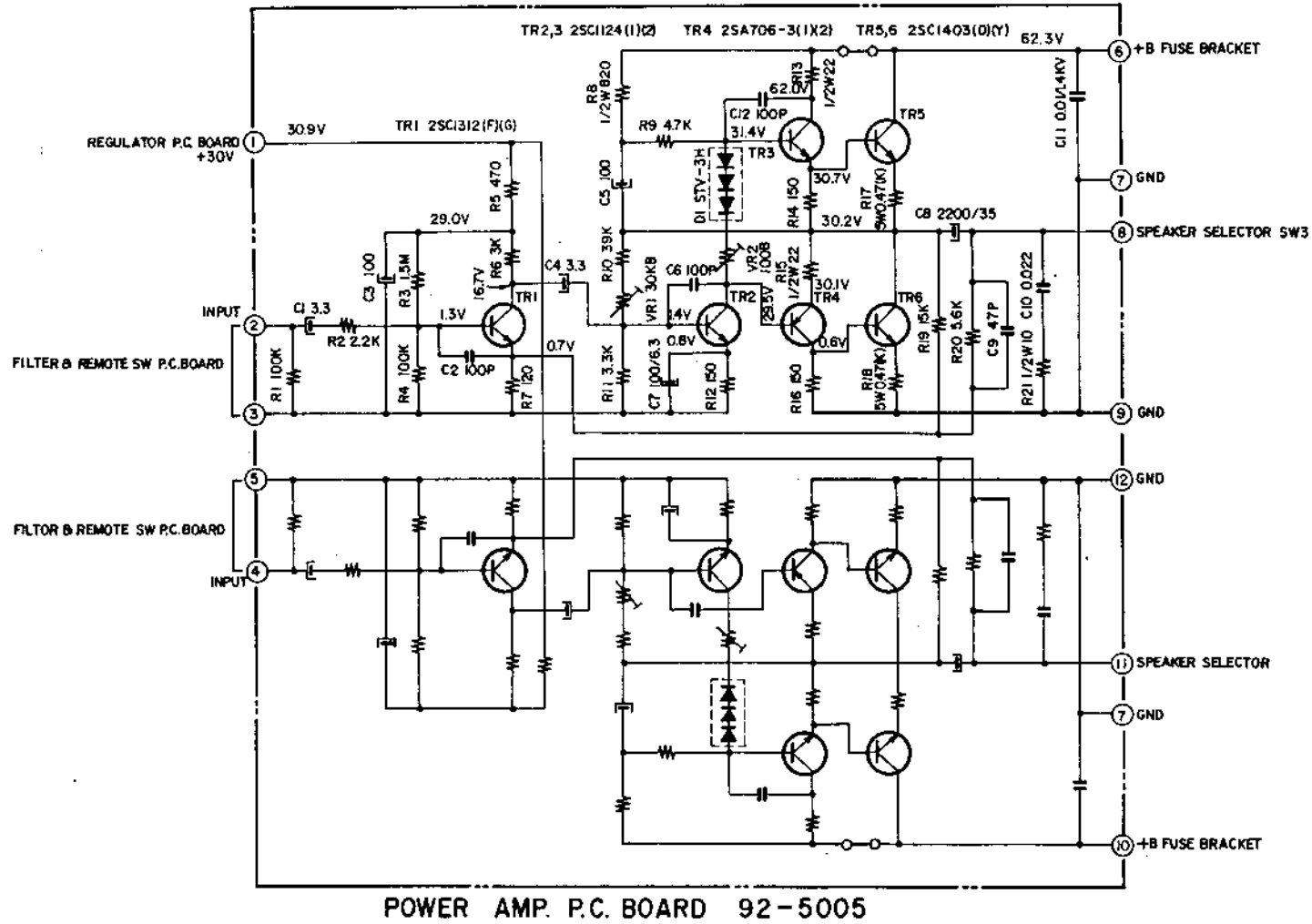
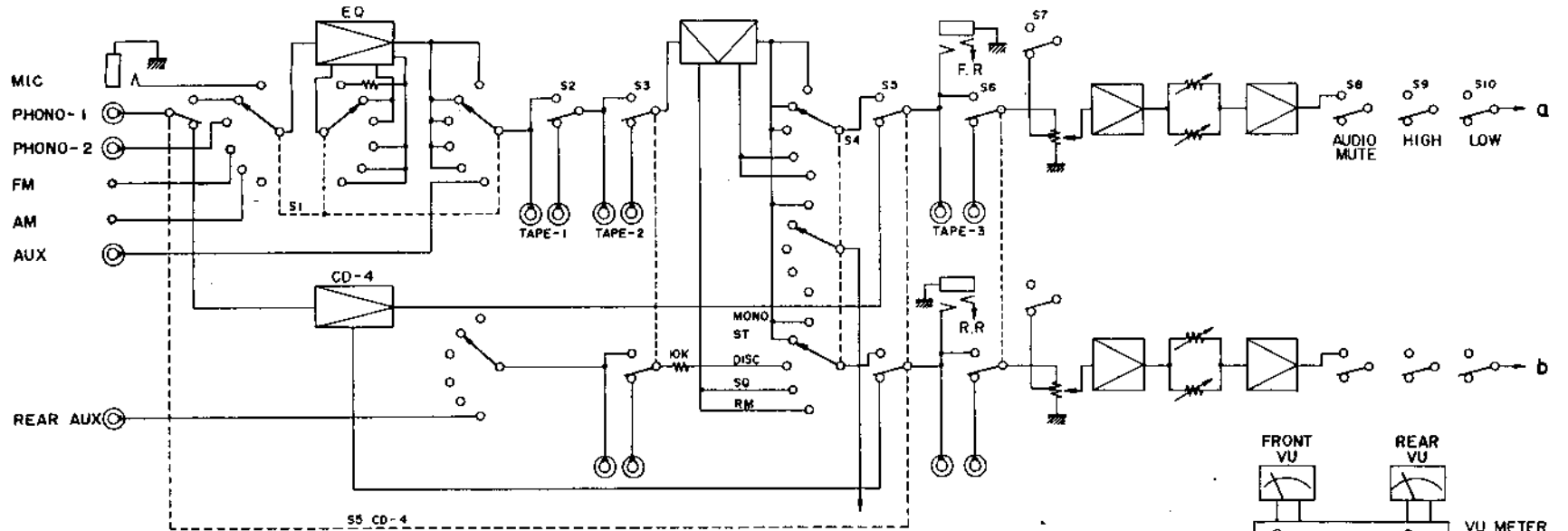

Fig. 42 POWER AMP. P.C. BOARD 92-5005



SCHEMATIC 5



- NOTE
- S1 INPUT SEL
 - S2 TAPE - 1
 - S3 TAPE - 2
 - S4 MODE SEL
 - S5 CD-4 SW
 - S6 TAPE - 3
 - S7 LOUDNESS
 - S8 AUDIO MUTE
 - S9 HIGH FILTER
 - S10 LOW FILTER
 - S11 REMOTE
 - S12 2CH. POWER UP
 - S13 SPEAKER SEL
 - S14 -10dB VU METER SENS
 - S15 -20dB VU METER SENS

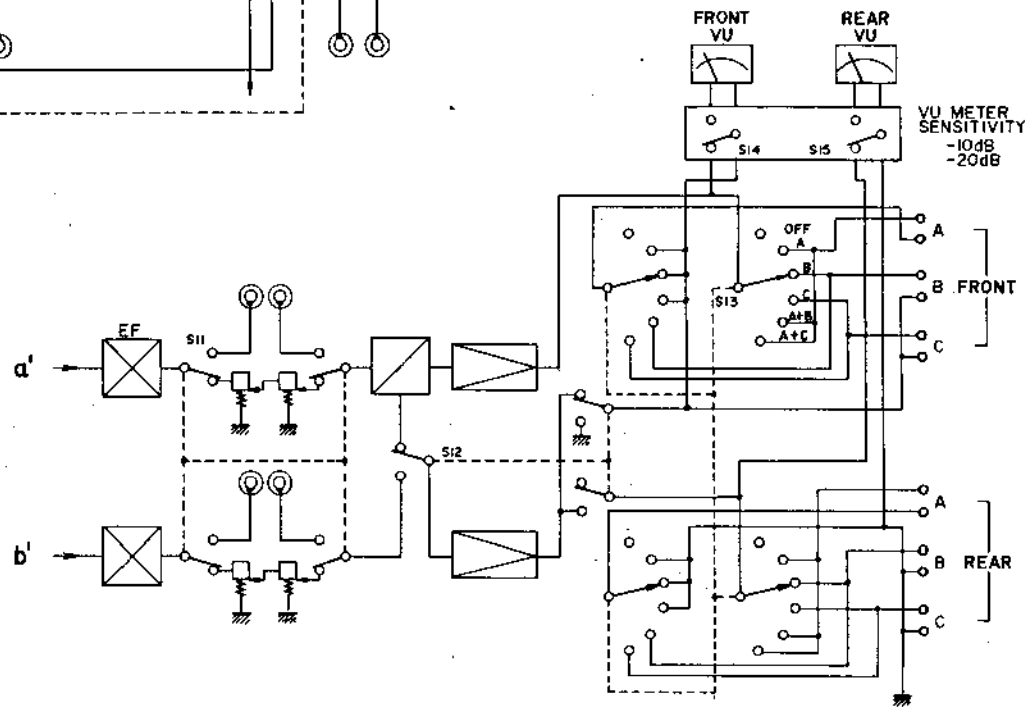

AS-980 AMP. SECTION BLOCK DIAGRAM (Left Channel Only)

2. SQ P.C. BOARD 98-5015

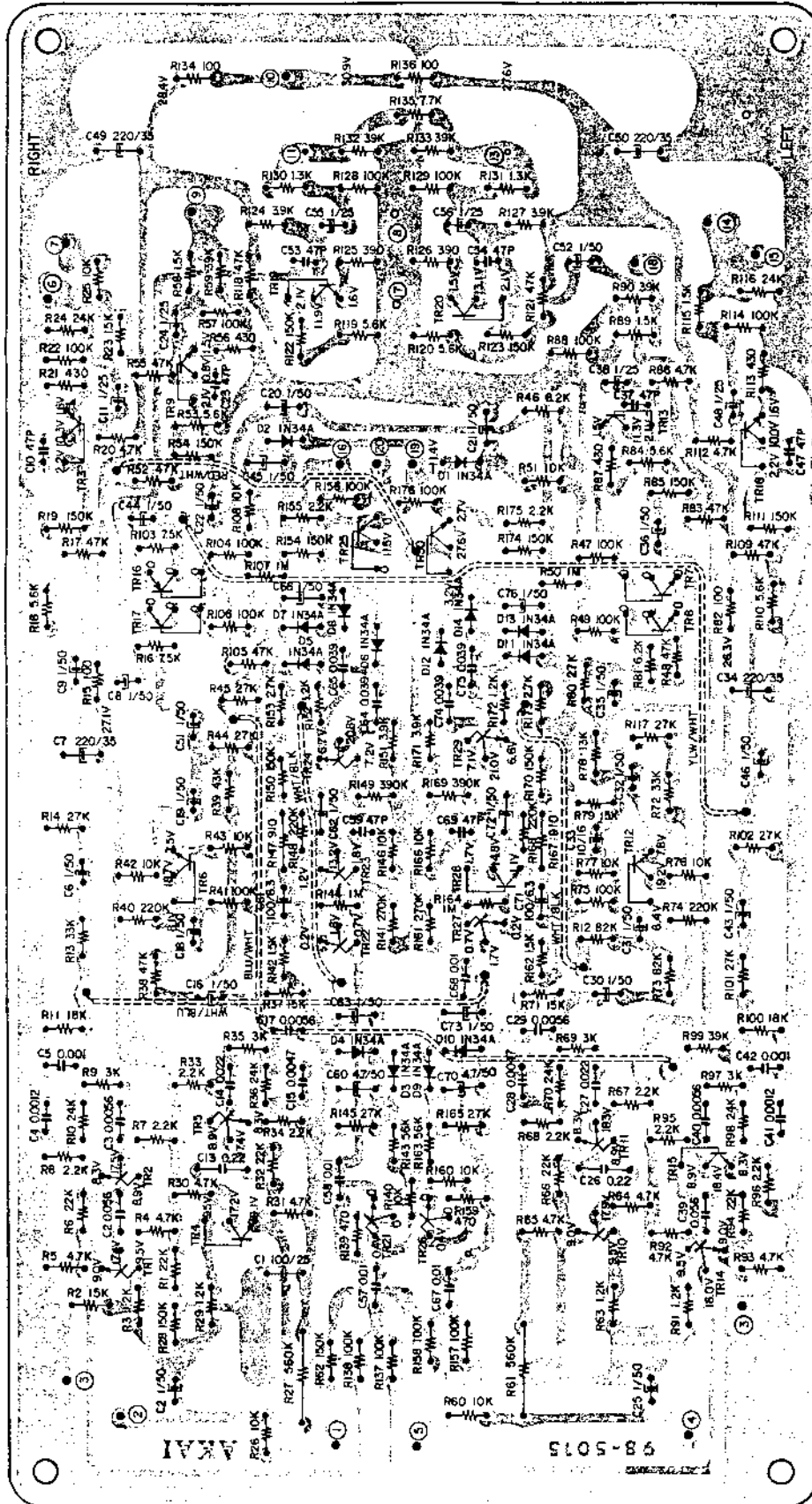

3. EQ AMP. P.C. BOARD 98-5008

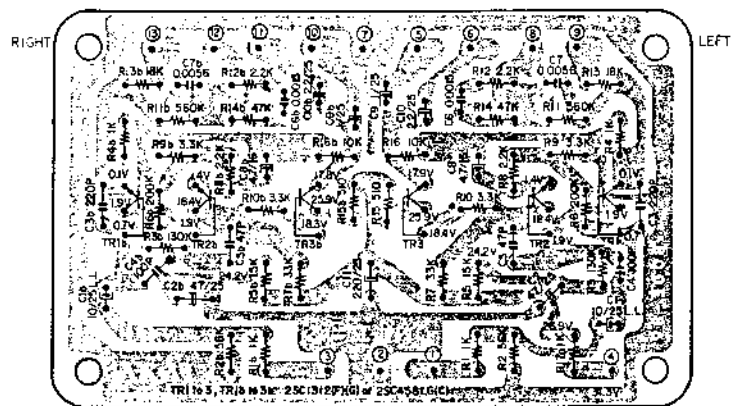

4. TAPE SW. P.C. BOARD 98-5002

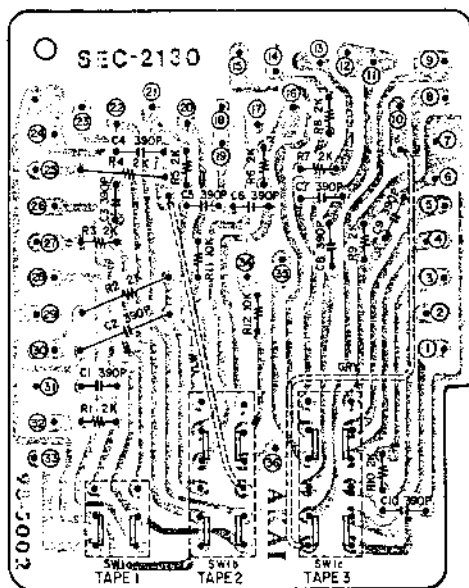

5. VOLUME CONTROL P.C. BOARD 98-5006

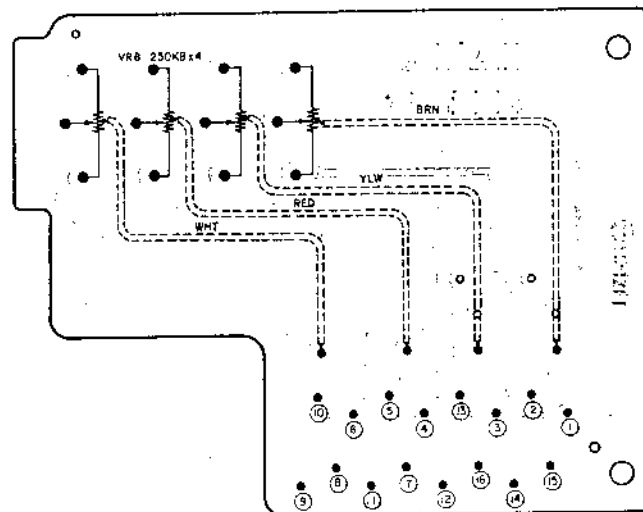

6. LOUDNESS SW. P.C. BOARD 98-5016

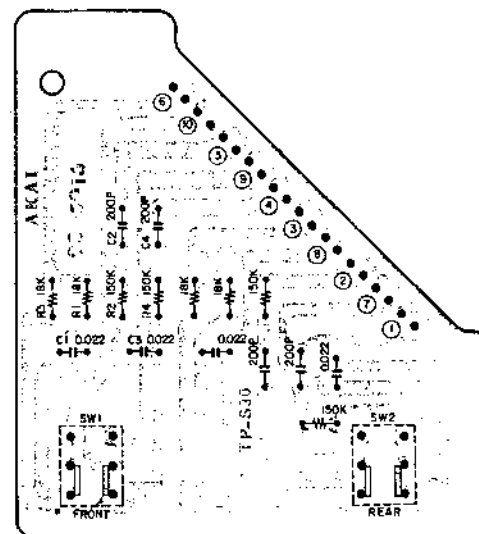

7. TONE CONTROL P.C. BOARD 98-5007

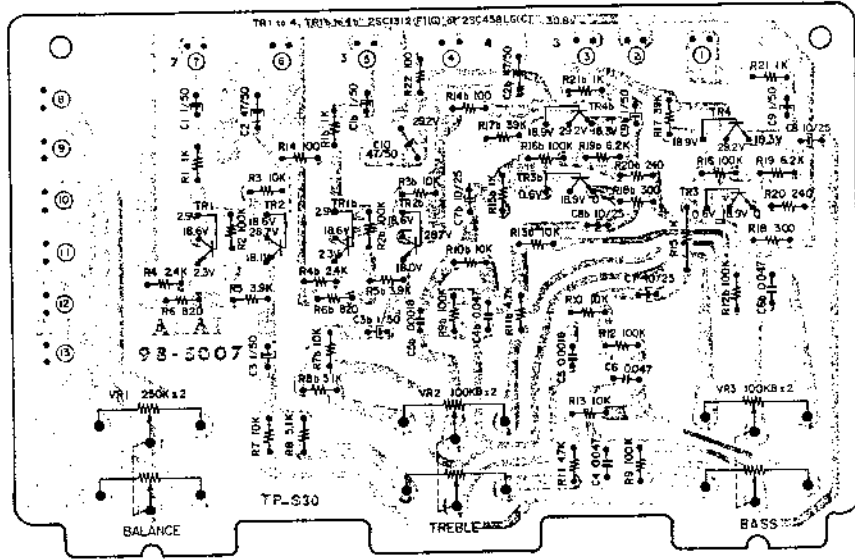

8. FILTER & REMOTE SW. P.C. BOARD 98-5014

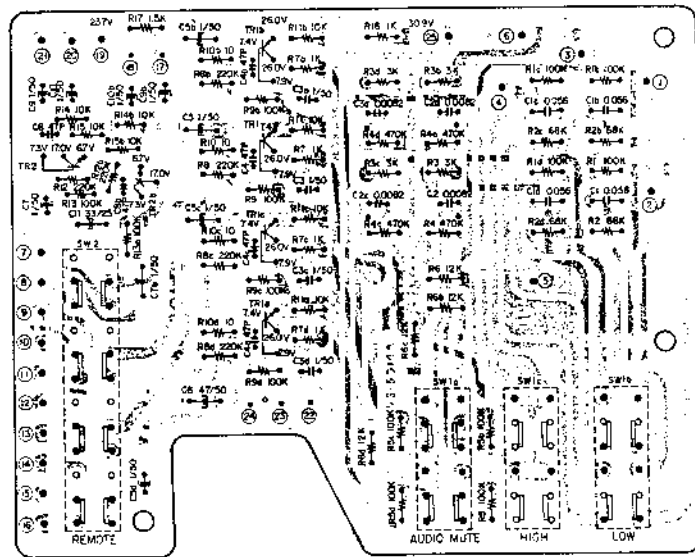

9. METER SW. P.C. BOARD 98-5003

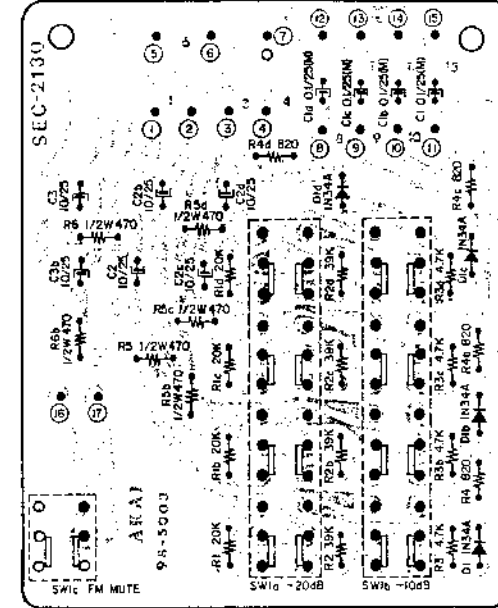

10. REGULATOR P.C. BOARD 98-5084

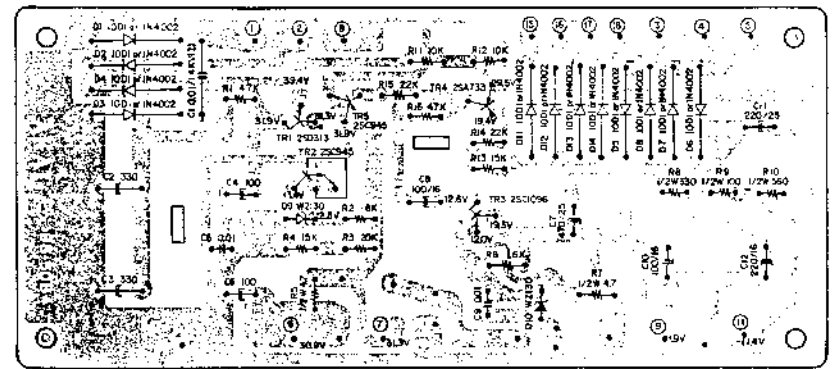

11. RECTIFIER P.C. BOARD (1) 98-5010

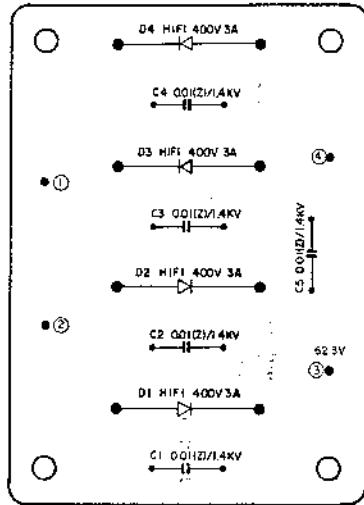

12. RESISTOR P.C. BOARD 98-5060

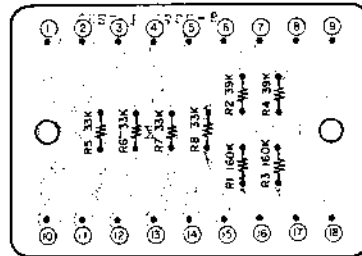

13. RECTIFIER P.C. BOARD (2) 98-5011

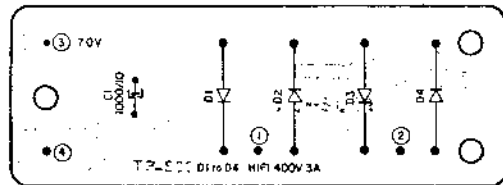

14. CD-4 SEPARATION P.C. BOARD 98-5005

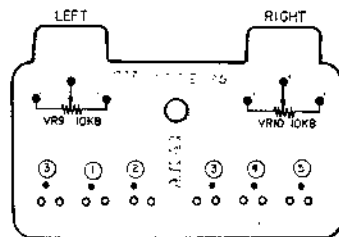

15. CD-4 SW. P.C. BOARD 98-5004

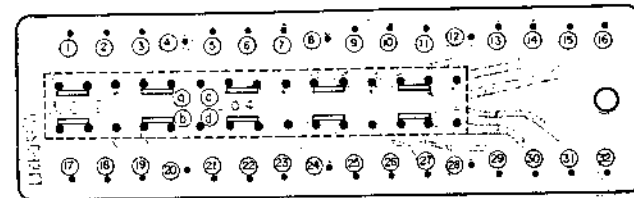

16. HEAD PHONE P.C. BOARD 98-5012

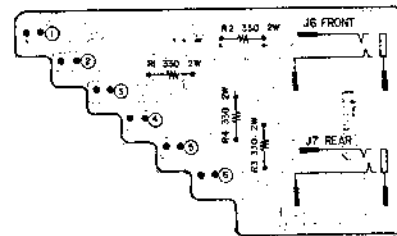

17. DUB P.C. BOARD 98-5013

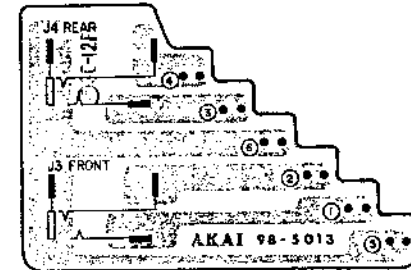

18. MIC P.C. BOARD 98-5059

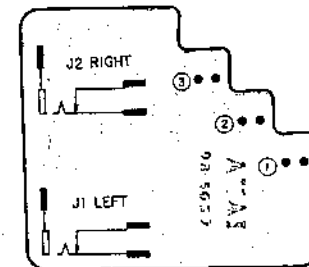

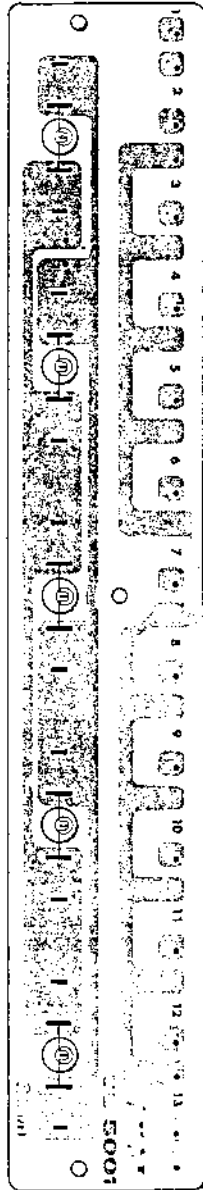

SECTION 2
PARTS LIST

TABLE OF CONTENTS

FIG. 1	IF P.C. BOARD (94-5009) BLOCK	54
FIG. 2	MPX P.C. BOARD (94-5008) BLOCK	56
FIG. 3	CD-4 P.C. BOARD (TDM-7) BLOCK	57
FIG. 4	SQ P.C. BOARD (98-5015) BLOCK	60
FIG. 5	MAIN AMP. P.C. BOARD (92-5005) BLOCK	63
FIG. 6	EQ. P.C. BOARD (98-5008) BLOCK	64
FIG. 7	REGULATOR P.C. BOARD (98-5084) BLOCK	65
FIG. 8	RECTIFIER P.C. BOARD (1) (98-5010) BLOCK	66
FIG. 9	RECTIFIER P.C. BOARD (2) (98-5011) BLOCK	66
FIG. 10	RESISTOR P.C. BOARD (98-5060) BLOCK	66
FIG. 11	TONE CONTROL P.C. BOARD (98-5007) BLOCK	67
FIG. 12	VOL. P.C. BOARD (98-5006) BLOCK	68
FIG. 13	SEP. P.C. BOARD (98-5005) BLOCK	68
FIG. 14	REMOTE P.C. BOARD (98-5014) BLOCK	69
FIG. 15	MIC. DUB P.C. BOARD (98-5059, 5013) BLOCK	70
FIG. 16	HP P.C. BOARD (98-5012) BLOCK	70
FIG. 17	LOUDNESS P.C. BOARD (98-5016) BLOCK	71
FIG. 18	METER P.C. BOARD (98-5003) BLOCK	71
FIG. 19	TAPE P.C. BOARD (98-5002) BLOCK	72
FIG. 20	CD-4 CHANGING P.C. BOARD (98-5004) BLOCK	72
FIG. 21	FRONT SHASSIS BLOCK	73
FIG. 22	SCALE PLATE/REAR PANEL BLOCK	74
FIG. 23	ASSEMBLY BLOCK	76
FIG. 24	FINAL ASSEMBLY BLOCK	78
INDEX		79

HOW TO USE THIS PARTS LIST

1. This parts list is compiled by various individual blocks based on assembly process.
2. When ordering parts, please describe parts number, serial number, and model number in detail.
3. How to read list.

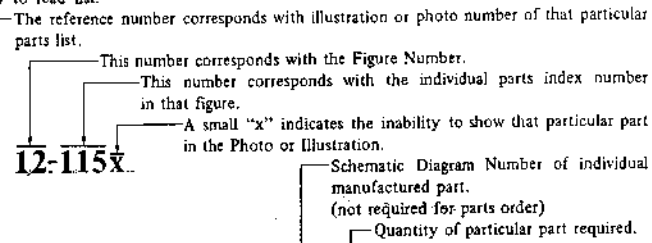

Ref. No.	Parts No.	Description	Schem. No.	Qty
FLYWHEEL BLOCK #13				
12-115x	800425	Flywheel Block Assy, Comp.	RD-212	1
12-116	244506	Flywheel Only	RD-213	1
12-117x	244754	Felt, Flywheel	RD-215	1
12-118	251324	Main Metal Case	RD-216	1
12-119	253080	Main Metal	RD-217	1

4. The symbol numbers shown on the P.C. Board list can be matched with the Composite Views of components of the Schematic Diagram or Service Manual.
5. The indications of Resistors and Capacitors in the photos of P.C. Board are being eliminated.
6. The shape of the parts and parts name, etc. can be confirmed by comparing them with the parts shown on the Electrical Parts Table of P.C. Board.
7. Both the kind of part and installation position can be determined by the Parts Number. To determine where a parts number is listed, utilize Parts Index at end of Parts List.

It is necessary first of all to find the Parts Number. This can be accomplished by using the Reference Number listed at right of parts number in the Parts Index. (meaning of ref. no. outlined in Item 3 above).

8. Utilize separate "Price List for Parts" to determine unit price. The most simple method of finding parts Price is to utilize the reference number.

NOTE: In the parts list US-A is the chief standard. Parts used in other than US-A standard areas are itemized by region. Parts not itemized by region can be used in all areas.

Standard	Packing Carton Sticker	AC Cord	Region	
US	US-A	AAL 120V	AC Cord CUL	
		EP 110V	AC Cord CUL	
	US-B	PRESET 220V	AC Cord CUL	Holland
		PRESET 110V	AC Cord CUL	110V Area
		PRESET 240V 3 CORE	3 Core without Plug	3 Core Area
		WG 220V	HEW-P79	WG
	CSA 220V	AC Cord CUL	CSA	
	CEE 220V	HEW-P65	CEE	
J	J 100V	AC Cord Domestic	Domestic	
A	SA 240V 3 CORE	3 Core without Plug	South Africa	

ELECTRICAL PARTS TABLE











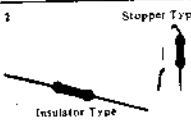









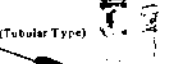



1	 Solid Resistor	2	 Stopper Type Carbon Resistor	3	 Metal Oxide Film Resistor
4	 Cement Resistor	5	 Wire-Wound Resistor	6	 Thermistor
7	 Enamel Resistor	8	 VFM (Hi-Q) Capacitor	9	 Mylar Capacitor
10	 MP Capacitor (Tubular Type)	11	 Plastic Capacitor	12	 Styro Capacitor
13	 Mylar Capacitor	14	 Tantalum Capacitor	15	 Oil Capacitor (Tubular Type)
16	 Electrolytic Capacitor (Tubular Type)	17	 Vertical Type Electrolytic Capacitor	18	 Ceramic Capacitor
19	 Metallized Mylar (Paper) Capacitor	20	 Trimmer Condenser	21	 Semi-Fixed Volume
22	 Ferrite Inductor	23	 Transistor	24	 Spark Quencher
25	 Diode (Silicon, Zener, Germanium)				

FIG. 1 PHOTO OF IF P.C. BOARD (94-5009)



IF P.C. BOARD (94-5009) BLOCK

Symbol No.	Parts No.	Description	Qty	Symbol No.	Parts No.	Description	Qty
1-1x	94500021	IF P.C. Board Comp. (94-5009)	1	1-R1	ER211667	Resistor, Stopper Type Carbon RD1/4 100(J)	1
1-2x	BA563850	IF P.C. Board Comp (94-5009) (US-B)	1	1-R2	ER212681	Carbon RD1/4 330(J)	1
1-IC1 to 4	E1469967	LC. LA-1221	4	1-R3	ER306887	Carbon RD1/4 15k(J)	1
1-TR1, 2	ET520034	Transistor 2SC922(L)	2	1-R4	ER212872	Carbon RD1/4 4.3k(J)	1
1-TR3 to 7	ET380834	Transistor 2SC711(F)	5	1-R5	ER212681	Carbon RD1/4 330(J)	1
1-TR8 to 11	ET427860	Transistor 2SC839(H)	4	1-R6	ER211465	Carbon RD1/4 1k(J)	1
1-D1 to 5	ED428364	Germanium Diode 1N60	5	1-R7	ER212883	Carbon RD1/4 4.7k(J)	1
1-D6, 7	ED379855	Germanium Diode 1N60P	2	1-R8	ER306884	Carbon RD1/4 1.2k(J)	1
1-D8	ED514721	Silicon Diode WG-599	1	1-R9	ER357491	Carbon RD1/4 82k(J)	1
1-D9 to 13	ED219464	Germanium Diode 1N34A	5	1-R10	ER306887	Carbon RD1/4 15k(J)	1
1-T1	FT551406	Trans. 05M-033-1329	1	1-R11, 12	ER212681	Carbon RD1/4 330(J)	2
1-T2	EO551395	FM Discr Coil 05M-033-1352B	1	1-R13	ER304290	Carbon RD1/4 10(J)	1
1-T3	EO551417	AM-RF Coil 05M-033-1326	1	1-R14	ER212681	Carbon RD1/4 330(J)	1
1-T4	EO551428	AM-OSC Coil 05M-033-1327	1	1-R15	ER371946	Carbon RD1/4 2k(J)	1
1-T5	BT379991	Trans. HI-137S (Yellow)	1	1-R16, 17	ER304290	Carbon RD1/4 10(J)	2
1-T6	BT380384	Trans. HI-134S (White)	1	1-R18	ER380913	Carbon RD1/4 33(J)	1
1-T7	BT443610	Trans. HI-144S (Black)	1	1-R19	ER399006	Carbon RD1/4 1.9k(J)	1
1-FL1 to 3	ER539818	Filter BFB 10.7MA5	3	1-R20	ER347073	Carbon RD1/4 200(J)	1
1-FL4	ER380406	Filter BFB 455B-5	1	1-R21, 22	ER211465	Carbon RD1/4 1k(J)	2
1-FL4	ER380417	Filter BFB 464-A	1	1-R23	ER211667	Carbon RD1/4 100(J)	1
1-L1, 2	EO539820	Peaking Coil 2.2k(HK)	2	1-R24	ER211858	Carbon RD1/4 12k(J)	1
1-VR1	EV380215	Semi-fixed Volume SR19R 100 kΩ (Solid type)	1	1-R25	ER349907	Carbon RD1/4 33k(J)	1
1-VR2	FV551452	Semi-fixed Volume SR19R 22 kΩ (Solid type)	1	1-R26	ER211757	Carbon RD1/4 100k(J)	1
1-3	EJ539662	Wrapping Post 1-17	20	1-R27	ER212764	Carbon RD1/4 22k(J)	1
1-C1, 2, 3	EC551441	Capacitor, Vertical Type Ceramic DD600YM 0.01μF (Z) 50WV	3	1-R28	ER430056	Carbon RD1/4 560k(J)	1
1-C4	EC368256	Elect. 0.47μF 25WV	1	1-R29	ER349907	Carbon RD1/4 33k(J)	1
1-C5, 6, 7	EC551441	Ceramic DD600YM 0.01μF (Z) 50WV	3	1-R30	ER392850	Carbon RD1/4 390k(J)	1
1-C8	EC483654	VFM 15PF(K) 50WV	1	1-R31	ER336442	Carbon RD1/4 10k(J)	1
1-C9 to 17	EC551441	Ceramic DD600YM 0.01μF (Z) 50WV	9	1-R32	ER212477	Carbon RD1/4 3.3k(J)	1
1-C18	EC336104	Elect. 100μF 6.3WV	1	1-R33	ER311858	Carbon RD1/4 12k(J)	1
1-C19, 20	EC551441	Ceramic DD600YM 0.01μF (Z) 50WV	2	1-R34	ER212681	Carbon RD1/4 330(J)	1
1-C21, 22	EC336216	VFM 330PF(J) 50WV	2	1-R15, 36	ER336442	Carbon RD1/4 10k(J)	2
1-C23	EC450527	Elect. 4.7μF 25WV	1	1-R37	ER357456	Carbon RD1/4 2.2k(J)	1
1-C24	EC336216	VFM 330PF(J) 50WV	1	1-R38	ER211465	Carbon RD1/4 1k(J)	1
1-C25	EC329771	Elect. 47μF 6.3WV	1	1-R39	ER212264	Carbon RD1/4 22k(J)	1
1-C26	EC313108	Elect. 1μF 50WV	1	1-R40	ER211667	Carbon RD1/4 100(J)	1
1-C27	EC290531	VFM 100PF(K) 50WV	1	1-R41	ER342933	Carbon RD1/4 27k(J)	1
1-C28, 29	EC551441	Ceramic DD600YM 0.01μF (Z) 50WV	2	1-R42	ER212883	Carbon RD1/4 4.7k(J)	1
1-C30	EC313108	Elect. 1μF 50WV	2	1-R43	ER357570	Carbon RD1/4 150k(J)	1
1-C31, 32	EC551441	Ceramic DD600YM 0.01μF (Z) 50WV	2	1-R44	ER304290	Carbon RD1/4 10(J)	1
1-C33	EC450527	Elect. 4.7μF 25WV	1	1-R45	ER357456	Carbon RD1/4 2.2k(J)	1
1-C34, 35	EC492142	Ceramic DD512YM 0.047μF (Z) 50WV	2	1-R46	ER211465	Carbon RD1/4 1k(J)	1
1-C36	EC427948	VFM 10PF(J) 50WV	1	1-R47	ER211757	Carbon RD1/4 100k(J)	1
1-C37, 38	EC492142	Ceramic DD512YM 0.047μF (Z) 50WV	2	1-R48	ER304290	Carbon RD1/4 10(J)	1
1-C39	EC250841	Mylar 0.01μF (J) 50WV	1	1-R49	ER211667	Carbon RD1/4 100(J)	1
1-C40	EC443632	VFM 430PF(J) 50WV	1	1-R50, 51	ER211465	Carbon RD1/4 1k(J)	2
1-C41	EC492142	Ceramic DD512YM 0.047μF (Z) 50WV	1	1-R52	ER211667	Carbon RD1/4 100(J)	1
1-C42	EC588494	VFM 13PF(J) 50WV	1	1-R53	ER419556	Carbon RD1/4 43k(J)	1
1-C43 to 45	EC492142	Ceramic DD512YM 0.047μF (Z) 50WV	3	1-R54	ER336442	Carbon RD1/4 10k(J)	1
1-C46	EC450527	Elect. 4.7μF 25WV	1	1-R55	ER407316	Carbon RD1/4 24k(J)	1
1-C47 to 51	EC492142	Ceramic DD512YM 0.047μF (Z) 50WV	5	1-R56, 57	ER211465	Carbon RD1/4 1k(J)	2
1-C52	EC329850	VFM 220PF(J) 50WV	1	1-R58	ER211667	Carbon RD1/4 100(J)	1
1-C53, 54	EC492142	Ceramic DD512YM 0.047μF (Z) 50WV	2	1-R59	ER304402	Carbon RD1/4 470(J)	1
1-C55	EC336104	Elect. 100μF 6.3WV	1	1-R60	ER306887	Carbon RD1/4 15k(J)	1
1-C56, 57	EC250841	Mylar 0.01μF (J) 50WV	2	1-R61	ER556754	Carbon RD1/4 91k(J)	1
1-C58	EC450527	Elect. 4.7μF 25WV	1	1-R62	ER357456	Carbon RD1/4 2.2k(J)	1

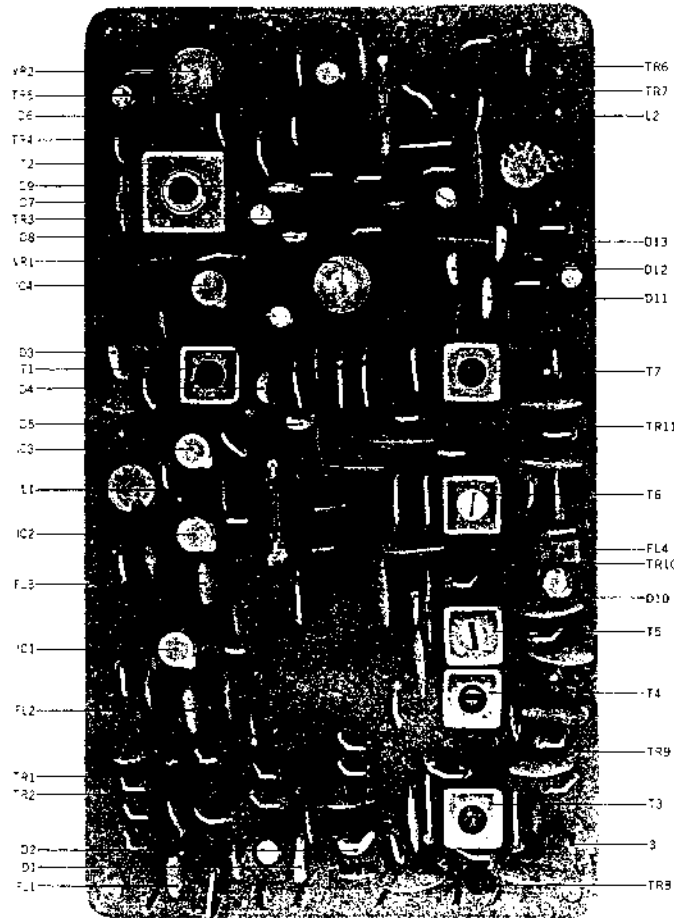
When ordering parts, please describe Parts Number, Serial Number, and Model Number in detail.

FIG. 2 PHOTO OF MPX P.C. BOARD (94-5008)

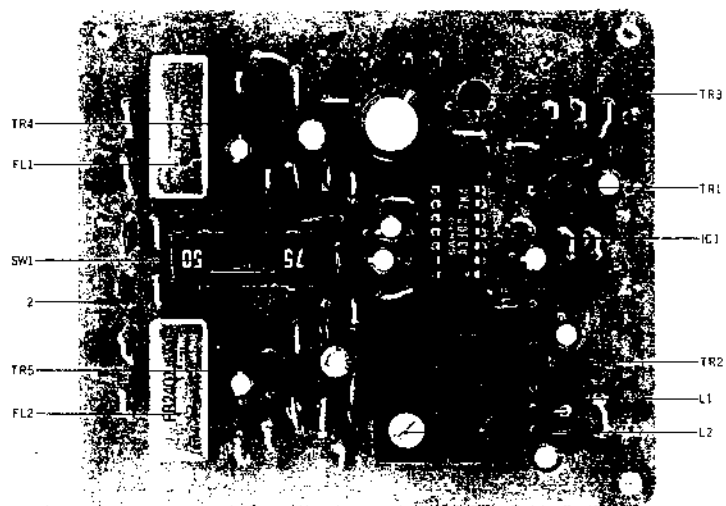

MPX P.C. BOARD (94-5008) BLOCK

Symbol No.	Parts No.	Description	Qty	Symbol No.	Parts No.	Description	Qty
2-1x	BA1574795	MPX P.C. Board Comp. (94-5008)	1	Resistor, Stopper Type			
2-IC1	E1443744	I.C. LA-3300	1	2-R1	ER346994	Carbon RD1/4 18k(J)	1
2-TR1	ET552870	FET 2SK30(Y) (GR)	1	2-R2	ER357491	Carbon RD1/4 82k(J)	1
2-TR2, 3	ET453486	Transistor 2SC711(E) (F)	2	2-R3	ER496214	Carbon RD1/4 360k(J)	1
2-TR4, 5	ET539987	Transistor 2SC1312 (F) (G)	2	2-R4	ER419040	Carbon RD1/4 1M(J)	1
2-D1, 2	ED219464	Germanium Diode 1N34A	2	2-R5	ER357491	Carbon RD1/4 82k(J)	1
2-L1	EO443766	Coil (19 KC) 02-1070.03	1	2-R6	ER496214	Carbon RD1/4 360k(J)	1
2-L2	EO443777	Coil (38 KC) 02-1064.03	1	2-R7	ER336442	Carbon RD1/4 10k(J)	1
		1064(White)	1	2-R8	ER211465	Carbon RD1/4 1k(J)	1
2-FL1, 2	ER512201	Filter FR-24	2	2-R9, 10	ER343078	Carbon RD1/4 2.7k(J)	2
2-SW1	ES13922	Slide SW. SSB02242	1	2-R11	ER357456	Carbon RD1/4 2.2k(J)	1
2-2	EJ539662	Wrapping Post 1x17	15	2-R12, 13	ER346601	Carbon RD1/4 47k(J)	2
				2-R14, 15	ER211465	Carbon RD1/4 1k(J)	2
Capacitor, Vertical Type				2-R16 to 19	ER380711	Carbon RD1/4 220k(J)	4
2-C1	EC331828	Elect. 3.3uF 25WV	1	2-R20, 21	ER212883	Carbon RD1/4 4.7k(J)	2
2-C2	EC250641	Mylar 0.01uF(J) 50WV	1	2-R22, 23	ER371946	Carbon RD1/4 2k(J)	2
2-C3	EC313244	Elect. 1uF 16WV	1	2-R24	ER212681	Carbon RD1/4 330(J)	1
2-C4	EC331828	Elect. 3.3uF 25WV	1	2-R25, 26	ER212883	Carbon RD1/4 4.7k(J)	2
2-C5	EC339096	Elect. 470uF 16WV	1	2-R27, 28	ER346601	Carbon RD1/4 47k(J)	2
2-C6	EC389474	Mylar 0.0015uF(J) 50WV	1	2-R29, 30	ER357535	Carbon RD1/4 39k(J)	2
2-C7	EC350706	Elect. 4.7uF 16WV	1				
2-C8, 9	EC220432	Elect. 2.2uF 25WV	2				
2-C10, 11	EC337500	Mylar 0.0047uF(J) 50WV	2				
2-C12, 13	EC250975	Mylar 0.015uF(I) 50WV	2				
2-C14, 15	EC220432	Elect. 2.2uF 35WV	2				
2-C16, 17	EC551463	Ceramic DD600YW 0.001uF(Z) 50WV	2				
2-C18, 19	EC350706	Elect. 4.7uF 16WV	2				
2-C20, 21	EC380621	Mylar 0.0068uF(J) 50WV	2				

When ordering parts, please describe Parts Number, Serial Number, and Model Number in detail.

FIG. 3 PHOTO OF CD-4 BOARD (TDM-7)

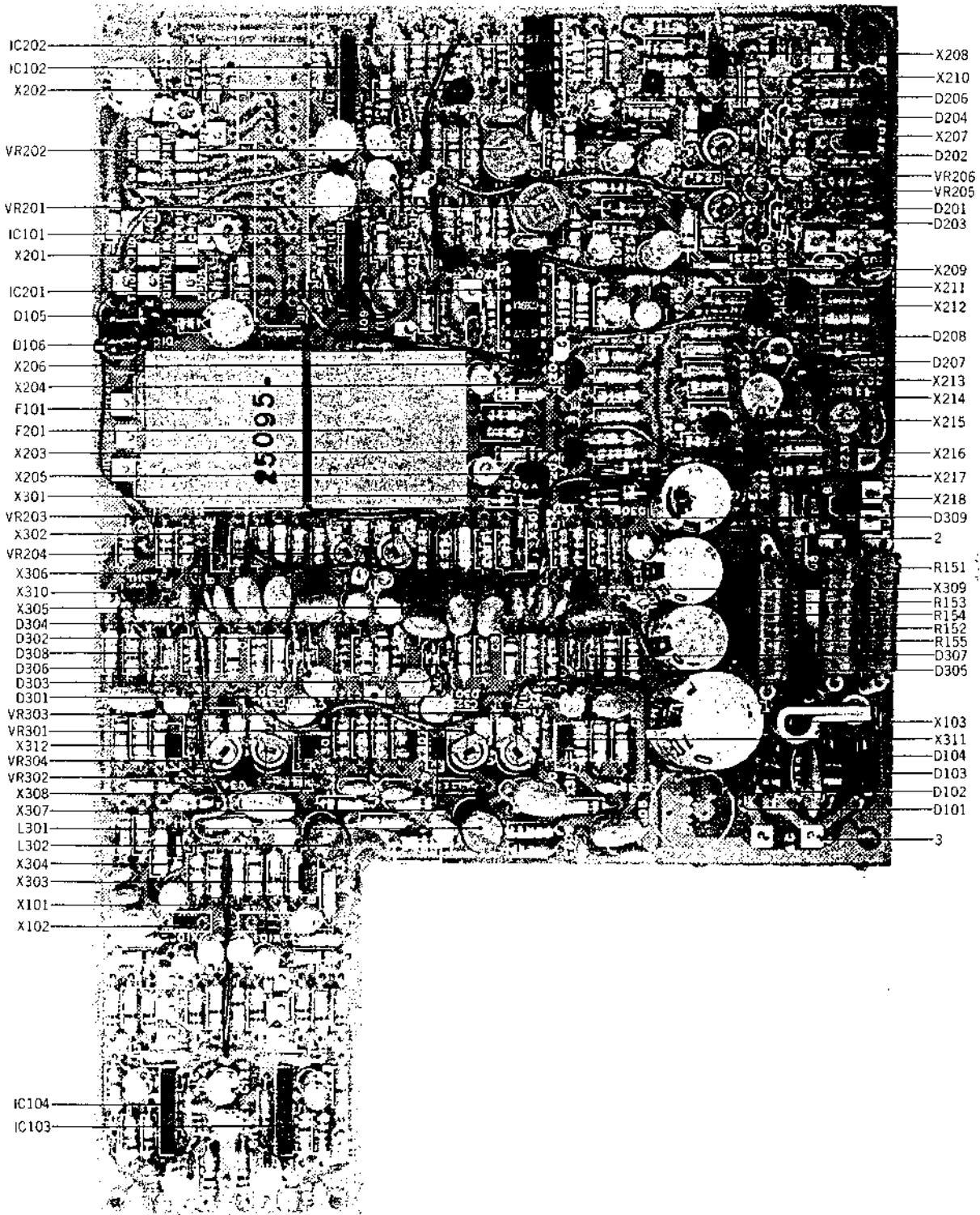
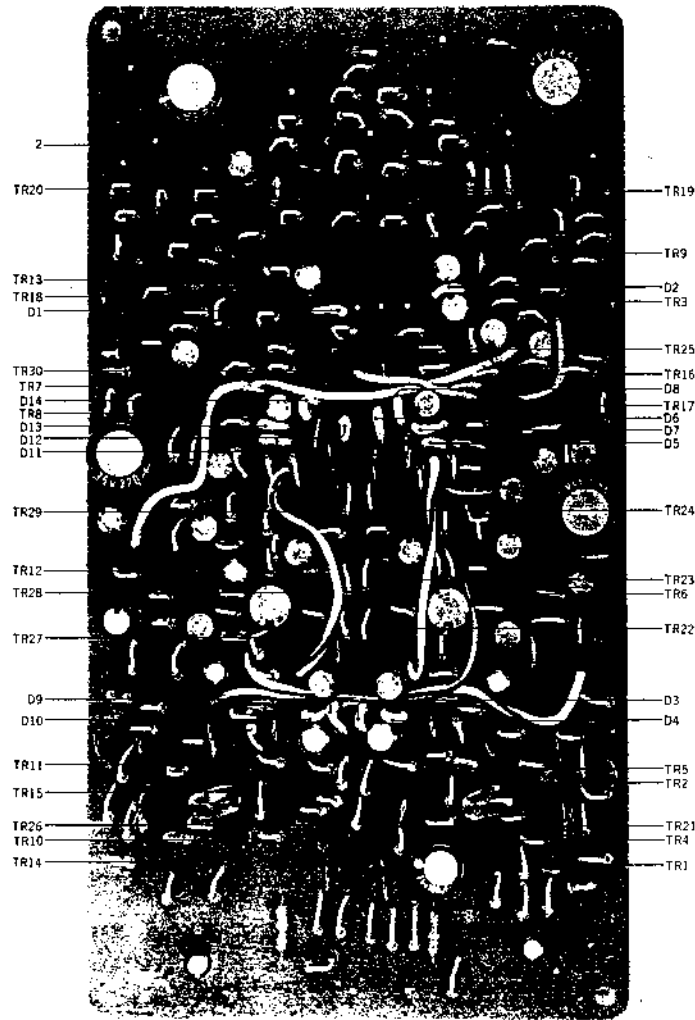

FIG. 4 PHOTO OF SQ P.C. BOARD (98-5015)



SQ P.C. BOARD (98-5015) BLOCK

Symbol No.	Parts No.	Description	Qty	Symbol No.	Parts No.	Description	Qty
4-1x	BA500643	SQ P.C. Board Comp. (98-5015)	1	4-R9	ER346544	Carbon RD1/4 3k(J)	1
A-TR1 to 6	ET539987	Transistor 2SC1312(F) (G)	6	4-R10	ER407316	Carbon RD1/4 24k(J)	1
4-TR7, 8	ET453486	Transistor 2SC711(E) (F)	2	4-R11	ER346994	Carbon RD1/4 18k(J)	1
4-TR9to15	ET539987	Transistor 2SC1312(F) (G)	7	4-R12	ER357491	Carbon RD1/4 82k(J)	1
4-TR16,17	ET557965	Transistor 2SA733(Q) (R)	2	4-R13	ER349907	Carbon RD1/4 33k(J)	1
4-TR18to20	ET539987	Transistor 2SC1312(F) (G)	3	4-R14	ER342933	Carbon RD1/4 27k(J)	1
4-TR21to24	ET453486	Transistor 2SC711(E) (F)	4	4-R15	ER211667	Carbon RD1/4 100(J)	1
4-TR25	ET557965	Transistor 2SA733(Q) (R)	1	4-R16	ER420232	Carbon RD1/4 7.5k(J)	1
4-TR26 to 30	ET453486	Transistor 2SC711(E) (F)	5	4-R17	ER346601	Carbon RD1/4 47k(J)	1
4-D1 to 14	ED219464	Germanium Diode 1N34A	14	4-R18	ER213030	Carbon RD1/4 5.6k(J)	1
4-2	EJ539662	Wrapping Post 1x17	20	4-R19	ER357570	Carbon RD1/4 150k(J)	1
				4-R20	ER212883	Carbon RD1/4 4.7k(J)	1
				4-R21	ER350065	Carbon RD1/4 430(J)	1
4-C1	EC220151	Capacitor, Vertical Type	1	4-R22	ER211757	Carbon RD1/4 100K(J)	1
4-C2	EC368357	Elect. 100µF 25WV	1	4-R23	ER211320	Carbon RD1/4 1.5k(J)	1
4-C3	EC329883	Mylar 0.056µF(J) 50WV	1	4-R24	ER407316	Carbon RD1/4 24k(J)	1
4-C4	EC379721	Mylar 0.0012µF(J) 50WV	1	4-R25	ER336442	Carbon RD1/4 10k(J)	1
4-C5	EC350875	Mylar 0.001µF(J) 50WV	1	4-R26	ER336442	Carbon RD1/4 10k(J)	1
4-C6	EC313108	Elect. 1µF 50WV	1	4-R27	ER514844	Carbon RD1/4 560k(J)	1
4-C7	EC372148	Elect. 220µF 35WV	1	4-R28	ER357570	Carbon RD1/4 150k(J)	1
4-C8, 9	EC313108	Elect. 1µF 50WV	2	4-R29	ER306843	Carbon RD1/4 1.2k(J)	1
4-C10	EC377212	VFM 47PF(J) 50WV	1	4-R30, 31	ER212883	Carbon RD1/4 4.7k(J)	2
4-C11	EC522516	Tantalum 1µF(M) 25WV	1	4-R32	ER212264	Carbon RD1/4 22k(J)	1
4-C12	EC313108	Elect. 1µF 50WV	1	4-R33, 34	ER357456	Carbon RD1/4 2.2k(J)	2
4-C13	EC338435	Mylar 0.22µF(J) 50WV	1	4-R35	ER346544	Carbon RD1/4 3k(J)	1
4-C14	EC368335	Mylar 0.022µF(J) 50WV	1	4-R36	ER407316	Carbon RD1/4 24k(J)	1
4-C15	EC337500	Mylar 0.0047µF(J) 50WV	1	4-R37	ER306887	Carbon RD1/4 15k(J)	1
4-C16	EC313108	Elect. 1µF 50WV	1	4-R38	ER346601	Carbon RD1/4 47k(J)	1
4-C17	EC329883	Mylar 0.0056µF(J) 50WV	1	4-R39	ER419526	Carbon RD1/4 43k(J)	1
4-C18to22	EC313108	Elect. 1µF 50WV	5	4-R40	ER380711	Carbon RD1/4 220k(J)	1
4-C23	EC377212	VFM 47PF(J) 50WV	1	4-R41	ER211757	Carbon RD1/4 100k(J)	1
4-C24	EC522516	Tantalum 1µF(M) 25WV	1	4-R42, 43	ER336442	Carbon RD1/4 10k(J)	2
4-C25	EC313108	Elect. 1µF 50WV	1	4-R44, 45	ER342933	Carbon RD1/4 27k(J)	2
4-C26	EC338435	Mylar 0.22µF(J) 50WV	1	4-R46	ER380755	Carbon RD1/4 6.2k(J)	1
4-C27	EC368335	Mylar 0.022µF(J) 50WV	1	4-R47	ER211757	Carbon RD1/4 100K(J)	1
4-C28	EC338500	Mylar 0.0047µF(J) 50WV	1	4-R48	ER346601	Carbon RD1/4 47k(J)	1
4-C29	EC329883	Mylar 0.0056µF(J) 50WV	1	4-R49	ER211757	Carbon RD1/4 100k(J)	1
4-C30to32	EC313108	Elect. 1µF 50WV	3	4-R50	ER419940	Carbon RD1/4 1M(J)	1
4-C33	EC320051	Elect. 10µF 16WV	1	4-R51	ER336442	Carbon RD1/4 10k(J)	1
4-C34	EC372148	Elect. 220µF 35WV	1	4-R52	ER346601	Carbon RD1/4 47k(J)	1
4-C35, 36	EC313108	Elect. 1µF 50WV	2	4-R53	ER213030	Carbon RD1/4 5.6k(J)	1
4-C37	EC377212	VFM 47PF(J) 50WV	1	4-R54	ER357570	Carbon RD1/4 150k(J)	1
4-C38	EC522516	Tantalum 1µF(M) 25WV	1	4-R55, 56	ER350065	Carbon RD1/4 430(J)	2
4-C39	EC368357	Mylar 0.056µF(J) 50WV	1	4-R57	ER211757	Carbon RD1/4 100k(J)	1
4-C40	EC329883	Mylar 0.056µF(J) 50WV	1	4-R58	ER211320	Carbon RD1/4 1.5k(J)	1
4-C41	EC379721	Mylar 0.0012µF(J) 50WV	1	4-R59	ER357535	Carbon RD1/4 39k(J)	1
4-C42	EC350875	Mylar 0.001µF(J) 50WV	1	4-R60	ER336442	Carbon RD1/4 10k(J)	1
4-C43to46	EC313108	Elect. 1µF 50WV	4	4-R61	ER514844	Carbon RD1/4 560k(J)	1
4-C47	EC377212	VFM 47PF(J) 50WV	1	4-R62	ER357570	Carbon RD1/4 150k(J)	1
4-C48	EC522516	Tantalum 1µF(M) 25WV	1	4-R63	ER306843	Carbon RD1/4 1.2k(J)	1
4-C49, 50	EC372148	Elect. 220µF 35WV	2	4-R64, 65	ER212883	Carbon RD1/4 4.7k(J)	1
4-C51, 52	EC313108	Elect. 1µF 50WV	2	4-R66	ER212264	Carbon RD1/4 22k(J)	1
4-C53, 54	EC377212	VFM 47PF(J) 50WV	2	4-R67, 68	ER357456	Carbon RD1/4 2.2k(J)	2
4-C55, 56	EC522516	Tantalum 1µF(M) 25WV	2	4-R69	ER346544	Carbon RD1/4 3k(J)	1
4-C57, 58	EC350841	Mylar 0.01µF(J) 50WV	2	4-R70	ER407316	Carbon RD1/4 24k(J)	1
4-C59	EC377212	VFM 47PF(J) 50WV	1	4-R71	ER306887	Carbon RD1/4 15k(J)	1
4-C60	EC317338	Elect. 4.7µF 50WV	1	4-R72	ER349907	Carbon RD1/4 33k(J)	1
4-C61	EC336104	Elect. 100kE 6.3WV	1	4-R73	ER357491	Carbon RD1/4 82k(J)	1
4-C62, 63	EC313108	Elect. 1µF 50WV	2	4-R74	ER380711	Carbon RD1/4 220k(J)	1
4-C64, 65	EC379192	Mylar 0.039µF(J) 50WV	2	4-R75	ER211757	Carbon RD1/4 100k(J)	1
4-C66	EC313108	Elect. 1µF 50WV	1	4-R76, 77	ER336442	Carbon RD1/4 10k(J)	2
4-C67, 68	EC250841	Mylar 0.01µF(J) 50WV	2	4-R78	ER430020	Carbon RD1/4 13k(J)	1
4-C69	EC377212	VFM 47PF(J) 50WV	1	4-R79	ER306887	Carbon RD1/4 15k(J)	1
4-C70	EC317338	Elect. 4.7µF 50WV	1	4-R80	ER342933	Carbon RD1/4 27k(J)	1
4-C71	EC336104	Elect. 100µF 6.3WV	1	4-R81	ER380755	Carbon RD1/4 6.2k(J)	1
4-C72, 73	EC313108	Elect. 1µF 50WV	2	4-R82	ER211667	Carbon RD1/4 100(J)	1
4-C74, 75	EC379192	Mylar 0.039µF(J) 50WV	2	4-R83	ER346601	Carbon RD1/4 47k(J)	1
4-C76	EC313108	Elect. 1µF 50WV	1	4-R84	ER213030	Carbon RD1/4 5.6k(J)	1
				4-R85	ER357570	Carbon RD1/4 150k(J)	1
				4-R86	ER212883	Carbon RD1/4 4.7k(J)	1
4-R1	ER212264	Carbon RD1/4 22k(J)	1	4-R87	ER350065	Carbon RD1/4 430(J)	1
4-R2	ER306887	Carbon RD1/4 15k(J)	1	4-R88	ER211757	Carbon RD1/4 100K(J)	1
4-R3	ER306843	Carbon RD1/4 1.2k(J)	1	4-R89	ER211320	Carbon RD1/4 1.5k(J)	1
4-R4, 5	ER212883	Carbon RD1/4 4.7k(J)	2	4-R90	ER357535	Carbon RD1/4 39k(J)	1
4-R6	ER212264	Carbon RD1/4 22k(J)	1	4-R91	ER306843	Carbon RD1/4 1.2k(J)	1
4-R7, 8	ER357456	Carbon RD1/4 2.2k(J)	2				

When ordering parts, please describe Parts Number, Serial Number, and Model Number in detail.

SQ P.C. BOARD (98-5015) BLOCK

Symbol No.	Parts No.	Description	Q'ty
4-R92, 93	ER212883	Carbon RD1/4 4.7k(J)	2
4-R94	ER212264	Carbon RD1/4 22k(J)	1
4-R95, 96	ER357456	Carbon RD1/4 2.2k(J)	2
4-R97	ER346544	Carbon RD1/4 3k(J)	1
4-R98	ER407316	Carbon RD1/4 24k(J)	1
4-R99	ER420322	Carbon RD1/4 36k(J)	1
4-R100	ER346994	Carbon RD1/4 18k(J)	1
4-R101, 1	ER342933	Carbon RD1/4 27k(J)	2
4-R103	ER420232	Carbon RD1/4 27k(J)	1
4-R104	ER211757	Carbon RD1/4 100k(J)	1
4-R105	ER346601	Carbon RD1/4 47k(J)	1
4-R106	ER211757	Carbon RD1/4 100k(J)	1
4-R107	ER419040	Carbon RD1/4 1M(J)	1
4-R108	ER336442	Carbon RD1/4 10k(J)	1
4-R109	ER346601	Carbon RD1/4 47k(J)	1
4-R110	ER213030	Carbon RD1/4 5.6k(J)	1
4-R111	ER357570	Carbon RD1/4 150k(J)	1
4-R112	ER212883	Carbon RD1/4 4.7k(J)	1
4-R113	ER350065	Carbon RD1/4 430(J)	1
4-R114	ER211757	Carbon RD1/4 100k(J)	1
4-R115	ER211320	Carbon RD1/4 1.5k(J)	1
4-R116	ER407316	Carbon RD1/4 24k(J)	1
4-R117	ER342933	Carbon RD1/4 27k(J)	1
4-R118	ER346601	Carbon RD1/4 47k(J)	1
4-R119, 20	ER213030	Carbon RD1/4 5.6k(J)	2
4-R121	ER346601	Carbon RD1/4 47k(J)	1
4-R122, 23	ER357570	Carbon RD1/4 150k(J)	2
4-R124	ER352045	Carbon RD1/4 3.9k(J)	1
4-R125, 26	ER346784	Carbon RD1/4 30k(J)	2
4-R127	ER352045	Carbon RD1/4 3.9k(J)	1
4-R128, 29	ER211757	Carbon RD1/4 100k(J)	2
4-R130, 31	ER395460	Carbon RD1/4 1.3k(J)	2
4-R132, 33	ER357535	Carbon RD1/4 39k(J)	2
4-R134	ER211667	Carbon RD1/4 100(J)	1
4-R135	ER343078	Carbon RD1/4 2.7k(J)	1
4-R136	ER211667	Carbon RD1/4 100(J)	1
4-R137, 38	ER211757	Carbon RD1/4 100k(J)	2
4-R139	ER304402	Carbon RD1/4 470(J)	1
4-R140	ER336442	Carbon RD1/4 10k(J)	1
4-R141	ER426857	Carbon RD1/4 270k(J)	1
4-R142	ER211320	Carbon RD1/4 1.5k(J)	1
4-R143	ER361528	Carbon RD1/4 56k(J)	1
4-R144	ER419040	Carbon RD1/4 1M(J)	1
4-R145	ER342933	Carbon RD1/4 27k(J)	1
4-R146	ER336442	Carbon RD1/4 10k(J)	1
4-R147	ER430108	Carbon RD1/4 910(J)	1
4-R148	ER380711	Carbon RD1/4 220k(J)	1
4-R149	ER392850	Carbon RD1/4 390k(J)	1
4-R150	ER357570	Carbon RD1/4 150k(J)	1
4-R151	ER352045	Carbon RD1/4 3.9k(J)	1
4-R152	ER306843	Carbon RD1/4 1.2k(J)	1
4-R153	ER343078	Carbon RD1/4 2.7k(J)	1
4-R154	ER357570	Carbon RD1/4 150k(J)	1
4-R155	ER357456	Carbon RD1/4 2.2k(J)	1
4-R156, 57, 58	ER211757	Carbon RD1/4 100k(J)	3
4-R159	ER304402	Carbon RD1/4 470(J)	1
4-R160	ER336442	Carbon RD1/4 10k(J)	1
4-R161	ER426857	Carbon RD1/4 270k(J)	1
4-R162	ER211320	Carbon RD1/4 1.5k(J)	1
4-R163	ER361528	Carbon RD1/4 56k(J)	1
4-R164	ER419040	Carbon RD1/4 1M(J)	1
4-R165	ER342933	Carbon RD1/4 27k(J)	1
4-R166	ER336442	Carbon RD1/4 10k(J)	1
4-R167	ER430108	Carbon RD1/4 910(J)	1
4-R168	ER380711	Carbon RD1/4 220k(J)	1
4-R169	ER392850	Carbon RD1/4 390k(J)	1
4-R170	ER357570	Carbon RD1/4 150k(J)	1
4-R171	ER352045	Carbon RD1/4 3.9k(J)	1
4-R172	ER306843	Carbon RD1/4 1.2k(J)	1
4-R173	ER343078	Carbon RD1/4 2.7k(J)	1
4-R174	ER357570	Carbon RD1/4 150k(J)	1
4-R175	ER357456	Carbon RD1/4 2.2k(J)	1
4-R176	ER211757	Carbon RD1/4 100k(J)	1

MAIN AMP. P.C. BOARD (92-5005) BLOCK

Symbol No.	Parts No.	Description	Q'ty
5-J1x	BA560610	Main Amp. P.C. Board Comp.	1
5-TR1	ET539987	Transistor 2SC1312(F) (G)	2
5-TR2, 3	ET551364	Transistor 2SC1124	4
5-TR4	ET556020	Transistor 2SA706-3(I) (2)	2
5-TR5, 6	ET557954	Transistor 2SC1402(G) (Y)	4
5-D1	ED556514	Varistor 5TV-3H	2
5-VR1	EV383398	Semi-fixed/Vol. V18K3-2	2
		30 kΩ(4US)	2
5-VR2	EV409858	Semi-fixed/Vol. V18K3-2	2
		100 ΩB(4US)	2
5-2	EJ550012	Wrapping Terminal T5280	12
5-3	E2543003	Heat-sink D	1
5-4x	AA541552	Transistor Mt. Plate	4
5-5	Z5463454	ISO Screw, binding head 3x15	8
5-6x	ZW348107	ISO Nut M3	8
5-7x	ZW259593	Washer (BSP) D3.4x7.8x0.51	8
5-8x	AA541563	Heat-sink Plate Mt. Parts	2
5-9x	Z5379405	ISO Screw, binding head 3x6	4
5-10	Z5321298	ISO Screw, binding head 3x8	2
5-11x	ZW426622	Washer (SPC) D3.4x7.8x0.51	2
		Capacitor, Vertical Type	
5-C1	EC539943	Elect. 3.3μF 50WV	2
5-C2	EC290531	VFM 100PF(K) 50WV	2
5-C3	EC321221	Elect. 100μF 50WV	2
5-C4	EC539943	Elect. 3.3μF 50WV	2
5-C5	EC321221	Elect. 100μF 50WV	2
5-C6	EC290531	VFM 100PF(K) 50WV	2
5-C7	EC220364	Elect. 100μF 6.3WV	2
5-C8	EC556176	Elect. 2200μF 35V	2
5-C9	EC487394	VFM 47PF(K) 50WV	2
5-C10	EC384085	Ceramic D820SYZ 0.022μF(Z) 50WV	2
5-C11	EC551160	Ceramic 0.01μF(Z) 1.4kWV	2
5-C12	EC290531	VFM 100PF(K) 50WV	2
		Resistor, Stopper Type	
5-R1	ER213715	Carbon RD1/4 100k(J) (Insu. Type)	2
5-R2	ER329264	Carbon RD1/4 2.1k(J)	1
5-R3	ER430007	Carbon RD1/4 1.5M(J)	1
5-R4	ER211757	Carbon RD1/4 100k(J)	2
5-R5	ER304402	Carbon RD1/4 470(J)	1
5-R6	ER346544	Carbon RD1/4 3k(J)	2
5-R7	ER433877	Carbon RD1/4 120(J)	2
5-R8	ER466582	Carbon RD1/2 820(J)	2
5-R9	ER212883	Carbon RD1/4 4.7k(J)	1
5-R10	ER357535	Carbon RD1/4 39k(J)	2
5-R11	ER212477	Carbon RD1/4 3.3k(J)	2
5-R12	ER212016	Carbon RD1/4 150(J)	2
5-R13	ER556042	Carbon RD1/2 22(J)	2
5-R14	ER212016	Carbon RD1/4 150(J)	2
5-R15	ER556042	Carbon RD1/4 22(J)	2
5-R16	ER212016	Carbon RD1/4 150(J)	2
5-R17, 18	ER556064	Metal Plate MPC71 F2 5W 0.47(K)	4
5-R19	ER306887	Carbon RD1/4 15k(J)	2
5-R20	ER213030	Carbon RD1/4 5.6k(J)	2
5-R21	ER451542	Carbon RD1/2 10(J)	2

FIG. 5 PHOTO OF MAIN AMP. P.C. BOARD (92-5005)

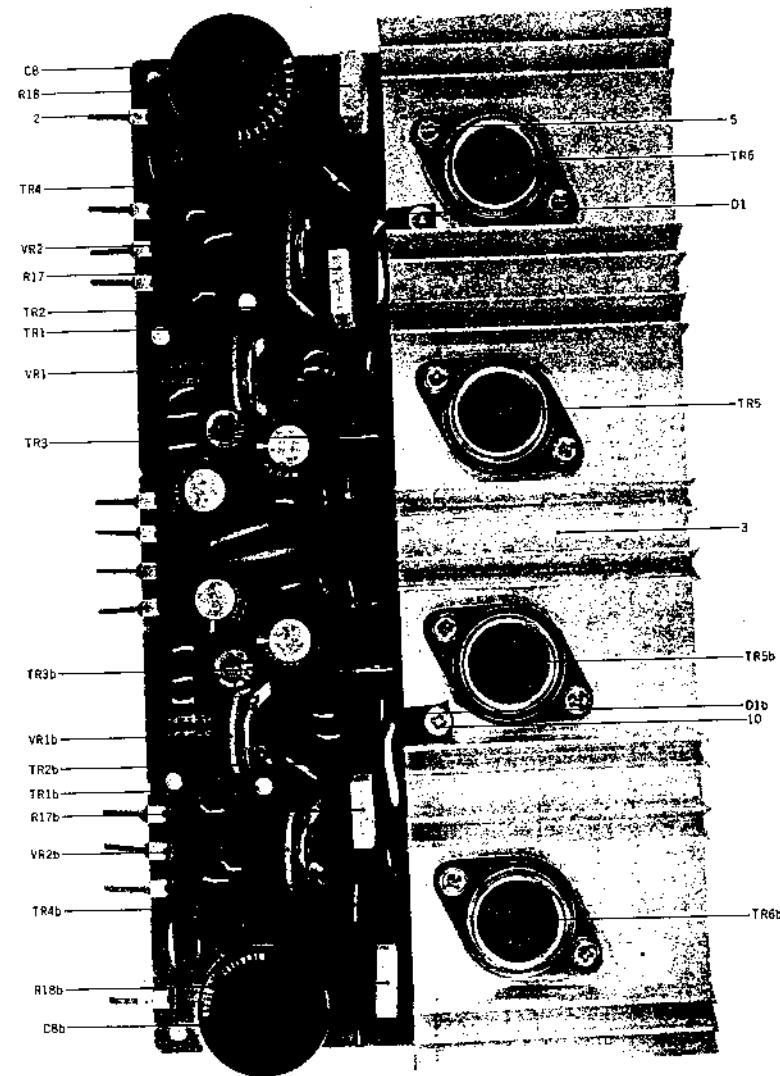

When ordering parts, please describe Parts Number, Serial Number, and Model Number in detail.

FIG. 6 PHOTO OF EQ. P.C. BOARD (98-5008)

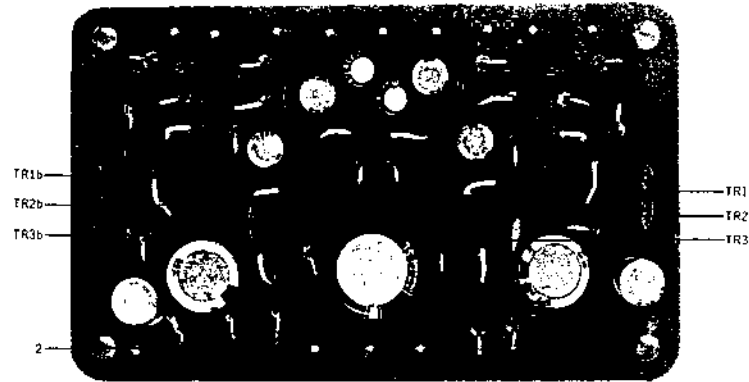

EQ. P.C. BOARD (98-5008) BLOCK

Symbol No.	Parts No.	Description	Q'ty
6-1x	BA560654	EQ. P.C. Board Comp. (98-5008)	1
6-TR1,2,3	ET539987	Transistor 2SC1312(F)(G)	6
6-2	EJ539662	Wrapping Post 1x17	13
Capacitor, Vertical Type			
6-C1	EC517138	Elect. 10 μ F 25WV NL	2
6-C2	EC220678	Elect. 47 μ F 25WV	2
6-C3	EC329850	VFM 220PF(J) 50WV	2
6-C4	EC190520	VFM 100PF(J) 50WV	2
6-C5	EC377212	VFM 47PF(J) 50WV	2
6-C6	EC389474	Mylar 0.001 μ F(I) 50WV	2
6-C7	EC329883	Mylar 0.0056 μ F(I) 50WV	2
6-C8	EC350706	Elect. 4.7 μ F 16WV	2
6-C9	EC450055	Elect. 1 μ F 25WV	2
6-C10	EC220432	Elect. 2.2 μ F 25WV	2
6-C11	EC313121	Elect. 220 μ F 25WV	2
Resistor, Stopper Type			
6-R1	ER211465	Carbon RD1/4 1k(I)	2
6-R2	ER361528	Carbon RD1/4 56k(I)	2
6-R3	ER211950	Carbon RD1/4 130k(I)	2
6-R4	ER211465	Carbon RD1/4 1k(I)	2
6-R5	ER306887	Carbon RD1/4 15k(I)	2
6-R6	ER362272	Carbon RD1/4 200k(I)	2
6-R7	ER349907	Carbon RD1/4 33k(I)	2
6-R8	ER357456	Carbon RD1/4 2.7k(I)	2
6-R9, 10	ER212477	Carbon RD1/4 3.3k(I)	4
6-R11	ER430086	Carbon RD1/4 560k(I)	2
6-R12	ER357456	Carbon RD1/4 2.2k(I)	2
6-R13	ER346994	Carbon RD1/4 18k(I)	2
6-R14	ER346601	Carbon RD1/4 47k(I)	2
6-R15	ER213096	Carbon RD1/4 510k(I)	2
6-R16	ER336442	Carbon RD1/4 10k(I)	2
6-R17	ER211465	Carbon RD1/4 1k(I)	2

FIG. 7 PHOTO OF REGULATOR P.C. BOARD (98-5084)

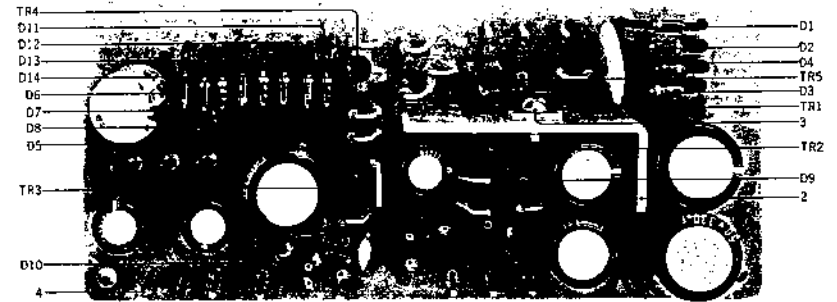

REGULATOR P.C. BOARD (98-5084) BLOCK

Symbol No.	Parts No.	Description	Q'ty
7-1x	BA570352	Regulator P.C. Board Comp. (98-5084)	1
7-TR1	ET557998	Transistor 2SC313(E)(F)	1
7-TR2	ET517994	Transistor 2SC945(P)(Q)(R)(K)	1
7-TR3	ET453611	Transistor 2SC1096(L)(K) (Z Type)	1
7-TR4	ET539122	Transistor 2SA733(P)(Q)(R)	1
7-TR5	ET517994	Transistor 2SC945(P)(Q)(R)(K)	1
7-D1 to 8	ED224526	Silicon Diode 10D1	8
7-D9, 10	ED539976	Zener Diode W2-130	2
7-D11 to 14	FD224526	Silicon Diode 10D1	4
7-2	AA545117	Heat-sink	1
7-3	ZS447772	Tapping Screw #2 3x6 (BR)	1
7-4	EJ539662	Wrapping Post 1x17	19
Capacitor, Vertical Type			
7-C1	EC551160	Ceramic 0.01 μ F(Z) 1.6kV	1
7-C2, 3	EC403468	Elect. 330 μ F 50WV	2
7-C4	EC321221	Elect. 100 μ F 50WV	1
7-C5	EC557627	Ceramic 0.01 μ F(Z) 50WV	1
7-C6	EC321221	Elect. 100 μ F 50WV	1
7-C7	EC331817	Elect. 470 μ F 25WV	1
7-C8	EC220127	Elect. 100 μ F 16WV	1
7-C9	EC557627	Ceramic 0.01 μ F(Z) 50WV	1
7-C10	EC321221	Elect. 100 μ F 50WV	1
7-C11	EC336115	Elect. 220 μ F 25WV	1
7-C12	EC321208	Elect. 220 μ F 16WV	1
Resistor, Stopper Type			
7-R1	ER212843	Carbon RD1/4 4.7k(I)	1
7-R2	ER362441	Carbon RD1/4 1.8k(I)	1
7-R3	ER349826	Carbon RD1/4 20k(I)	1
7-R4	ER306887	Carbon RD1/4 15k(I)	1
7-R5	ER520852	Carbon RD1/4 4.7k(I)	1
7-R6	ER343135	Carbon RD1/4 1.6k(I)	1
7-R7	ER520852	Carbon RD1/2 4.7k(I)	1
7-R8	ER483390	Carbon RD1/2 330k(I)	1
7-R9	ER458726	Carbon RD1/2 100k(I)	1
7-R10	ER497417	Carbon RD1/2 560k(I)	1
7-R11, 12	ER336442	Carbon RD1/4 10k(I)	2
7-R13	ER306887	Carbon RD1/4 15k(I)	1
7-R14, 15	ER212664	Carbon RD1/4 22k(I)	2
7-R16	ER346601	Carbon RD1/4 47k(I)	1

When ordering parts, please describe Parts Number, Serial Number, and Model Number in detail.

When ordering parts, please describe Parts Number, Serial Number, and Model Number in detail.

FIG. 8 PHOTO OF RECTIFIER P.C. BOARD (1) (98-5010)

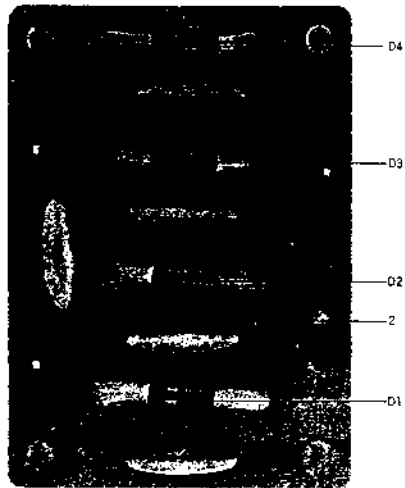

RECTIFIER P.C. BOARD (1) (98-5010) BLOCK

Symbol No.	Parts No.	Description	Q'ty
4-1x	BA560676	Rectifier P.C. Board(1) Comp. (98-5010)	1
8-D1 to 4	ED558033	Silicon Diode HiFi 400V 3A (Special)	4
4-2	EJ539662	Wrapping Post 1x17	4
8-C1 to 5	EC551160	Ceramic(C. 0.01 μ F(Z) 1.4kWV	5

FIG. 9 PHOTO OF RECTIFIER P.C. BOARD (2) (98-5011)



RECTIFIER P.C. BOARD (2) (98-5011) BLOCK

Symbol No.	Parts No.	Description	Q'ty
9-1x	BA560687	Rectifier P.C. Board (2) Comp.(98-5011)	1
9-D1 to 4	ED558033	Silicon Diode HiFi 400V 3A(Special)	4
9-2	EJ539662	Wrapping Post 1x17	4
9-C1	EC220410	Elect./C. 1000 μ F 10WV(Vert. Type)	1

FIG. 10 PHOTO OF RESISTOR P.C. BOARD (98-5060)

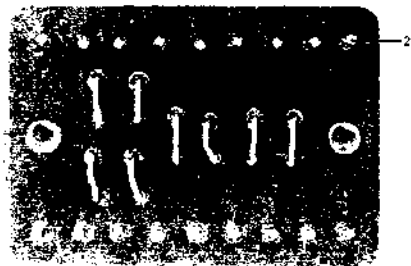

RESISTOR P.C. BOARD (98-5060) BLOCK

Symbol No.	Parts No.	Description	Q'ty
10-1x	BA560632	Resistor P.C. Board Comp. (98-5060)	1
10-2	EJ539662	Wrapping Post 1x17	18
Resistor, Stopper Type			
10-R1	ER404087	Carbon RD1/4 160k(J)	1
10-R2	ER357535	Carbon RD1/4 39k(J)	1
10-R3	ER404087	Carbon RD1/4 160k(J)	1
10-R4	ER357535	Carbon RD1/4 39k(J)	1
10-R5to8	ER349907	Carbon RD1/4 33k(J)	4

FIG. 11 PHOTO OF TONE CONTROL P.C. BOARD (98-5007)

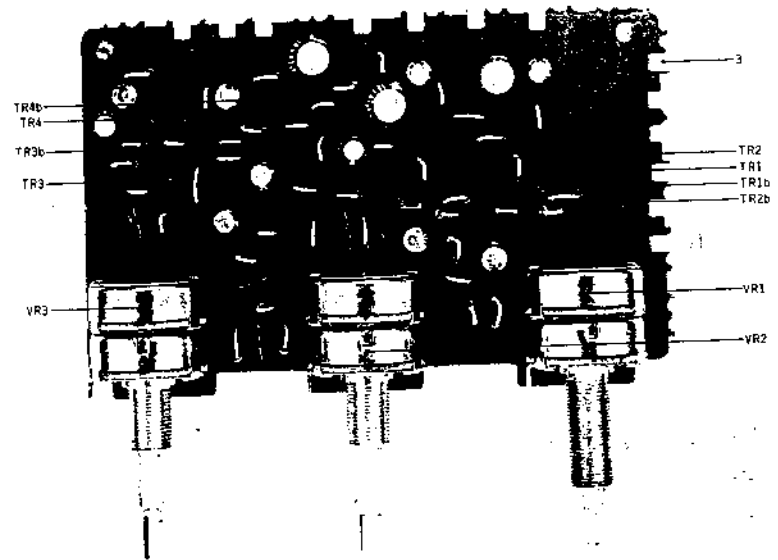

TONE CONTROL P.C. BOARD (98-5007) BLOCK

Symbol No.	Parts No.	Description	Q'ty	Symbol No.	Parts No.	Description	Q'ty
11-1x	BA560496	Tone Control P.C. Board Comp. (98-5007)	1	11-R1	ER211465	Resistor, Stopper Type Carbon RD1/4 1k(J)	2
11-2x	BA560507	Tone Control P.C. Board Comp. (98-5007) (USB)	1	11-R2	ER211757	Carbon RD1/4 100k(J)	2
11-TR1 to 4	ETS39987	Transistor 2SC1312(F) (G)	8	11-R3	ER336442	Carbon RD1/4 10k(J)	2
11-VR1	EV557921	Co-axial 2-throw Vol. (w/click) V24LSGPHN 1Z 250 k Ω x2	1	11-R4	ER430042	Carbon RD1/4 2.4k(J)	2
11-VR2, 3	EV555941	Co-axial 20throw Vol. (w/click) V24LSGPHN 1kB 100k Ω x2	2	11-R5	ER352045	Carbon RD1/4 3.9k(J)	2
11-3	EJ539673	Wrapping Terminal T5290	13	11-R6	ER213465	Carbon RD1/4 820(J)	2
11-4x	EJ557932	Wrapping Terminal T5303	13	11-R7	ER336442	Carbon RD1/4 10k(J)	2
Capacitor, Vertical Type				11-R8	ER324202	Carbon RD1/4 100k(J)	2
11-C1	EC313108	Elect. 1 μ F 50WV	2	11-R9	ER211757	Carbon RD1/4 10k(J)	2
11-C2	EC346735	Elect. 47 μ F 50WV	2	11-R10	ER336442	Carbon RD1/4 4.7k(J)	2
11-C3	EC313108	Elect. 1 μ F 50WV	2	11-R11	ER212883	Carbon RD1/4 4.7k(J)	2
11-C4	EC379214	Mylar 0.047 μ F(I) 50WV	2	11-R12	ER211757	Carbon RD1/4 100k(J)	2
11-C5	EC424708	Mylar 0.0018 μ F(J) 50WV	2	11-R13	ER336442	Carbon RD1/4 10k(J)	2
11-C6	EC379214	Mylar 0.047 μ F(I) 50WV	4	11-R14	ER211667	Carbon RD1/4 100(J)	2
11-C7, 8	EC220994	Elect. 10 μ F 25WV	2	11-R15	ER211465	Carbon RD1/4 1k(J)	2
11-C9	EC313108	Elect. 1 μ F 50WV	1	11-R16	ER211757	Carbon RD1/4 39k(J)	2
11-C10	EC346735	Elect. 47 μ F 50WV	1	11-R17	ER357535	Carbon RD1/4 300(J)	2
				11-R18	ER361620	Carbon RD1/4 6.2k(J)	2
				11-R19	ER380755	Carbon RD1/4 240(J)	2
				11-R20	ER406912	Carbon RD1/4 1k(J)	2
				11-R21	ER211465	Carbon RD1/4 100(J)	1
				11-R22	ER211667	Carbon RD1/4 100(J)	1

FIG. 12 PHOTO OF VOL. P.C. BOARD
(98-5006)

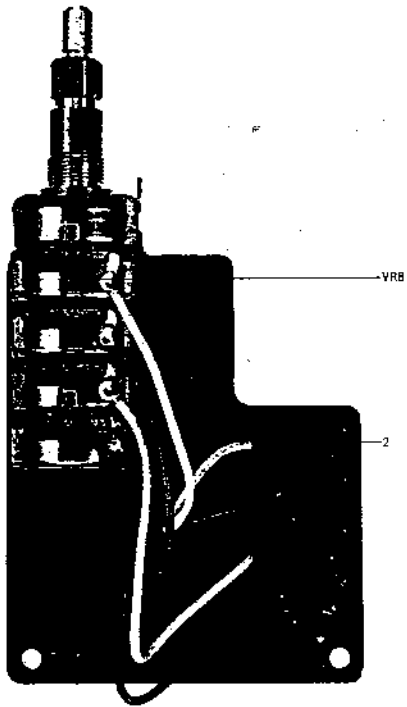

VOL. P.C. BOARD (98-5006) BLOCK

Symbol No.	Parts No.	Description	Q'ty
12-1x	BA560424	Vol. P.C. Board Comp. (98-5006)	1
12-VR5	EV557842	Co-axial 4-Throw Vol. (w/pre set) V24LSDPHN 2BL 25D K17x4	1
12-2	E1539662	Wrapping Post 1x17	16

FIG. 13 PHOTO OF SEP P.C. BOARD
(98-5005)

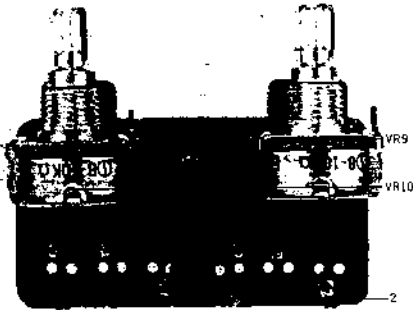

SEP P.C. BOARD (98-5005) BLOCK

Symbol No.	Parts No.	Description	Q'ty
13-1x	BA560463	SEP P.C. Board Comp. (98-5005)	1
13-VR9, 10	EV557831	Vol. V16L4PHN 410 kΩ	2
13-2	E1539662	Wrapping Post 1x17	6

FIG. 14 PHOTO OF REMOTE P.C. BOARD (98-5014)

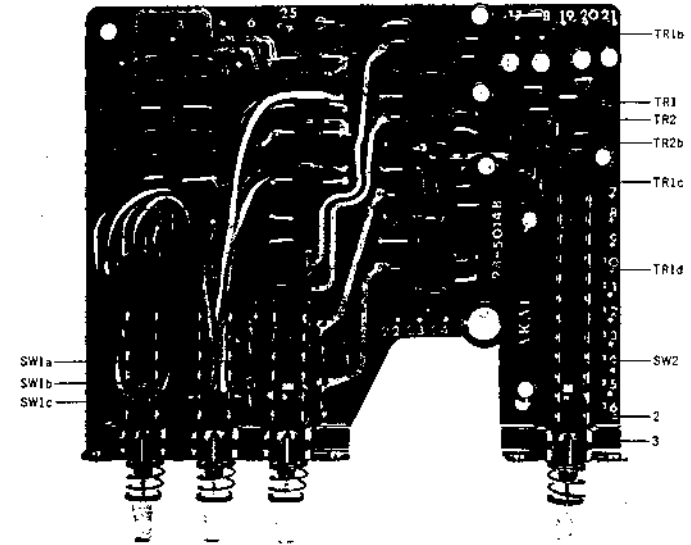

REMOTE P.C. BOARD (98-5014) BLOCK

Symbol No.	Parts No.	Description	Q'ty	Symbol No.	Parts No.	Description	Q'ty
14-1x	BA560485	Remote P.C. Board Comp. (98-5014)	1	14-R1	ER211757	Resistor, Stopper Type	4
14-TR1, 2	ET539987	Transistor 2SC1313(F) (G)	6	14-R2	ER350100	Carbon RD1/4 68k(J)	4
14-SW1	ES591118	Push SW JPT-0001 DF-1320	1	14-R3	ER346544	Carbon RD1/4 3k(J)	4
14-SW2	ES591107	Push SW IPT-0001 AF-1320	1	14-R4	ER429996	Carbon RD1/4 470k(J)	4
14-ISx	E1537910	Socket CS289	1	14-R5	ER211757	Carbon RD1/4 100k(J)	4
14-2	E1539662	Wrapping Post 1x17	25	14-R6	ER211858	Carbon RD1/4 12k(J)	4
14-3	A2544803	Push SW Mt. Plate	1	14-R7	ER211465	Carbon RD1/4 1k(J)	4
14-4x	ZS371856	ISO Screw, binding head 3x5	6	14-K8	ER380711	Carbon RD1/4 220k(J)	4
14-5x	A2544814	Din Jack Mt. Plate	1	14-R9	ER211757	Carbon RD1/4 100k(J)	4
		Capacitor, Vertical Type		14-R10	ER304290	Carbon RD1/4 10(J)	4
14-C1	EC368357	Mylar 0.056μF(J) 50WV	4	14-R11	ER336442	Carbon RD1/4 10k(J)	4
14-C2	EC411827	Mylar 0.0082μF(J) 50WV	4	14-R12	ER380711	Carbon RD1/4 220k(J)	2
14-C3	EC522516	Tantalum 1μF(M) 25WV (Dts Type)	4	14-R13	ER211757	Carbon RD1/4 100k(J)	2
14-C4	EC377212	VFM 47PF(J) 50WV	4	14-R14, 15	ER336442	Carbon RD1/4 10k(J)	4
14-C5	EC313108	Elect. 1μF 50WV	4	14-R16	ER211465	Carbon RD1/4 1k(J)	1
14-C6	EC346735	Elect. 47μF 50WV	1	14-R17	ER211320	Carbon RD1/4 1.5k(J)	1
14-C7	EC313108	Elect. 1μF 50WV	2				
14-C8	EC487394	VFM 47PF(K) 50WV	2				
14-C9, 10	EC313108	Elect. 1μF 50WV	4				
14-C11	EC220612	Elect. 33μF 25WV	1				

When ordering parts, please describe Parts Number, Serial Number, and Model Number in detail.

When ordering parts, please describe Parts Number, Serial Number, and Model Number in detail.

FIG. 15 PHOTO OF MIC, DUB P.C. BOARD
(98-5059, 5013)

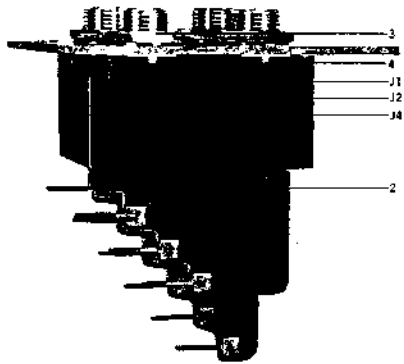

MIC, DUB P.C. BOARD (98-5059, 5013) BLOCK

Symbol No.	Parts No.	Description	Q'ty
15-1x	BA560520	Mic, Dub P.C. Board Comp. (98-5059, 5013)	1
15-J1, 2	EJ391094	Mic. Jack 2PM11P	2
15-J3, 4	EJ391083	Mic. Jack 3PM11P	2
15-2	EJ550012	Wrapping Terminal TS280	9
15-3	ZW270191	E Jack Nut	4
15-4	AZ545106	Jack Mt. Plate	1

FIG. 16 PHOTO OF HP P.C. BOARD
(98-5012)

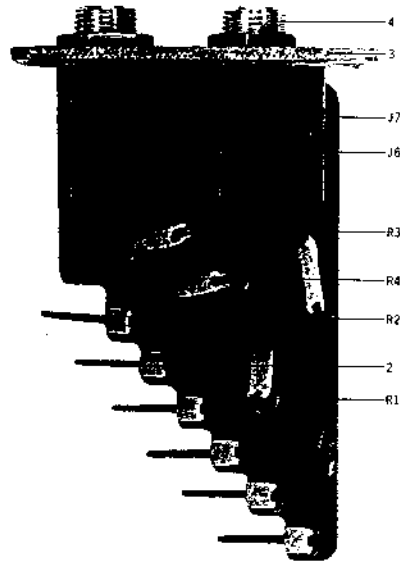

HP P.C. BOARD (98-5012) BLOCK

Symbol No.	Parts No.	Description	Q'ty
16-1x	BA560531	HP P.C. Board Comp. (98-5012)	1
16-J6, 7	EJ437321	Jack, 3P Molded 3PM11P	2
16-2	EJ550012	Wrapping Terminal TS280	6
16-3	AZ544836	Hone Jack Mt. Plate	1
16-4	ZW270191	E Jack Nut	2
16-R1 to 4	ER559034	Metal Oxide Film/R. 2W 330Ω(K)	4

FIG. 17 PHOTO OF LOUDNESS P.C. BOARD
(98-5016)

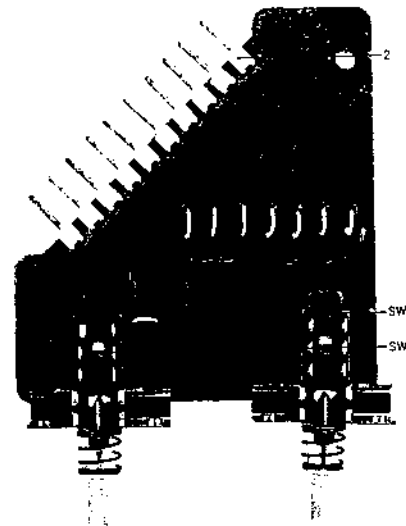

LOUDNESS P.C. BOARD (98-5016) BLOCK

Symbol No.	Parts No.	Description	Q'ty
17-1x	BA560518	Loudness P.C. Board Comp. (98-5016)	1
17-SW1, 2	ES551171	Push SW. 1FS-2U-12	2
17-2	EJ550012	Wrapping Terminal TS280	10
Capacitor, Vertical Type			
17-C1	EC368335	Mylar 0.022μF(J) 50WV	2
17-C2	EC389237	VFM 200PF(J) 50WV	2
17-C3, 4	EC368335	Mylar 0.022μF(J) 50WV	4
Resistor, Stopper Type			
17-R1	ER346994	Carbon RD1/4 18k(J)	2
17-R2	ER357570	Carbon RD1/4 150k(J)	2
17-R3	ER346994	Carbon RD1/4 18k(J)	2
17-R4	ER357570	Carbon RD1/4 150k(J)	2

FIG. 18 PHOTO OF METER P.C. BOARD
(98-5003)

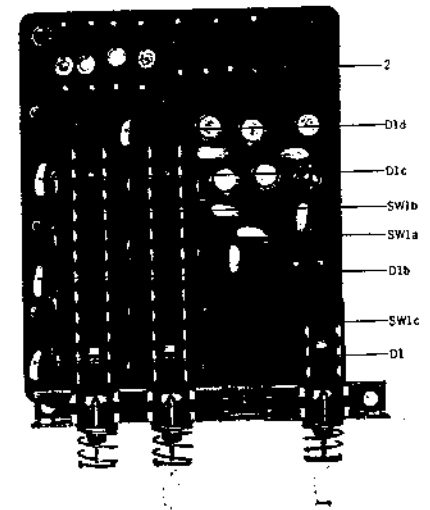

METER P.C. BOARD (98-5003) BLOCK

Symbol No.	Parts No.	Description	Q'ty
18-1x	BA560441	Meter P.C. Board Comp. (98-5003)	1
18-D1	ED19464	Germanium Diode 1N34A	4
18-SW1	ES557785	Push Switch 3FS-18U-461-1	1
18-2	EJ539662	Wrapping Post 1x17	17
Capacitor, Vertical Type			
18-C1	EC523282	Solid Aluminum 0.1μF(M) 25WV	4
18-C2	EC720994	Elect. 10μF 25WV	6
Resistor, Stopper Type			
18-R1	ER349828	Carbon RD1/4 20k(J)	4
18-R2	ER357535	Carbon RD1/4 39k(J)	4
18-R3	ER212883	Carbon RD1/4 4.7k(J)	4
18-R4	ER213467	Carbon RD1/4 820(J)	4
18-R5	ER557796	Carbon RD1/2 470(K)	6

FIG. 19 PHOTO OF
TAPE P.C. BOARD (98-5002)

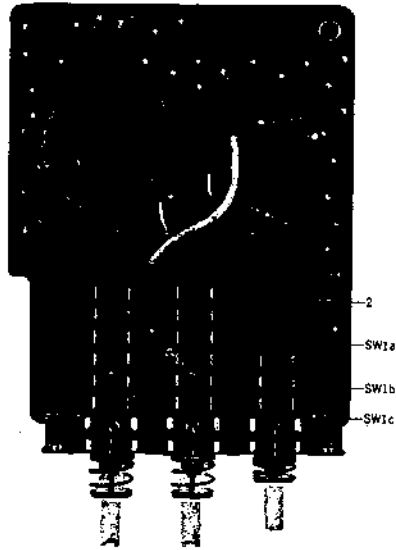
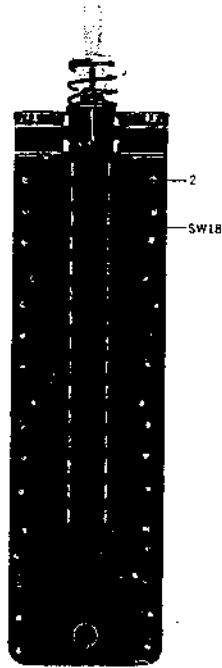

FIG. 20 PHOTO OF
CD-4 CHANGING P.C. BOARD (98-5004)



TAPE P.C. BOARD (98-5002) BLOCK

Symbol No.	Parts No.	Description	Q'ty
19-1x	BA560430	Tape P.C. Board Comp. (98-5002)	1
19-SW1	ES557774	Push Switch JFS-10U-461	1
19-2	EJ539662	Wrapping Post 1x17	37
19-C1to10	EC557616	Ceramic/C. 390PF(K) 50WV	10
Resistor, Stopper Type			
19-R1	ER371946	Carbon RD1/4 2k(J)	1
19-R2	ER392534	Carbon RD1/4 2k(J)	1
19-R3	ER371946	Carbon RD1/4 2k(J)	1
19-R4	ER392534	Carbon RD1/4 2k(J)	1
19-R5to10	ER371946	Carbon RD1/4 2k(J)	1
19-R11,12	ER336442	Carbon RD1/4 10k(J)	1

CD-4 CHANGING P.C. BOARD (98-5004) BLOCK

Symbol No.	Parts No.	Description	Q'ty
20-1x	BA560452	CD-4 Changing P.C. Board Comp. (98-5004)	1
20-SW18	ES591130	Push Switch 1FT-0002 AF-1320	1
20-2	EJ539662	Wrapping Post 1x17	32

FIG. 21 PHOTO OF FRONT SHASSIS BLOCK

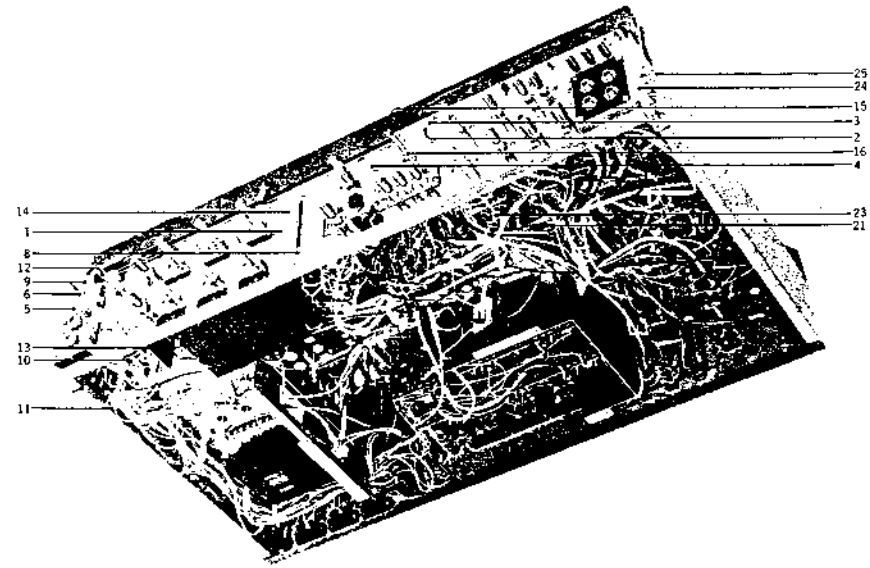

FRONT SHASSIS BLOCK

Ref. No.	Parts No.	Description	Schematic No.	Q'ty
21-1	AZ545207	Front Chassis	98-5011	1
21-2	ZS430684	Roller Screw B (L=13)	91-5900	3
21-3	MR530662	Roller B (D=10)	91-5909	3
21-4	MR530651	Roller A (D=14)	91-5908	1
21-5	AZ544825	Power SW. Retaining Angle	98-5036	1
21-6	ES468448	Lever SW. SDD4LFJO (LPS60122FJOG)	25-4-B	1
21-7x	EC551160	Ceramic/C. 0.01uF(Z) 1.4kVW	14-6-B	2
21-8	ZS371856	ISO Screw, binding head 3x5		8
21-9	ZS447772	Tapping Screw #2 3x6 (BR)		4
21-10	ES560183	Rotary SW. SR32N 4-12-6	25-1-35	1
21-11	MZ219138	W're Bundle Holder N-108	7-35-1	13
21-12	ES560294	Rotary SW. SR32N-3-8-2	25-7-31	1
21-13	AZ544858	Shield Plate B	98-5029	1
21-14	EV557741	4-throw Slide/Vol (Center-click) VJ458G4RN-1Z 250kx4	26-3-1	1
21-15	MSS30152	Tuning Shaft	91-5018	1
21-16	AA530741	Tuning Metal	91-5017	1
21-17x	ZW260122	Washer D6.1x10x11 (Nylon)		2
21-18x	BF530763	Flywheel	91-5908	1
21-19x	ZS462936	ISO Set Screw, hexagon socket 3x5 (cup/p.)		1
21-20x	AZ544847	Rotary SW. Mt. Plate	98-5028	1
21-21	ES557752	Rotary SW. Y8-18-6	25-7-34	1
21-22x	ER427961	Carbon/R. RD1/A 43k(J) (Insu. type)	25-9-5	2
21-23	ES557763	Rotary SW. SR26N 5-15-5 35KH	24-6-B	1
21-24	AZ545095	Jack Mt. Plate Angle	98-5022	1
21-25	ZS447772	Tapping Screw #2 3x6 (BR)		4

When ordering parts, please describe Parts Number, Serial Number, and Model Number in detail.

When ordering parts, please describe Parts Number, Serial Number, and Model Number in detail.

FIG. 22 PHOTO OF SCALE PLATE/REAR PANEL BLOCK

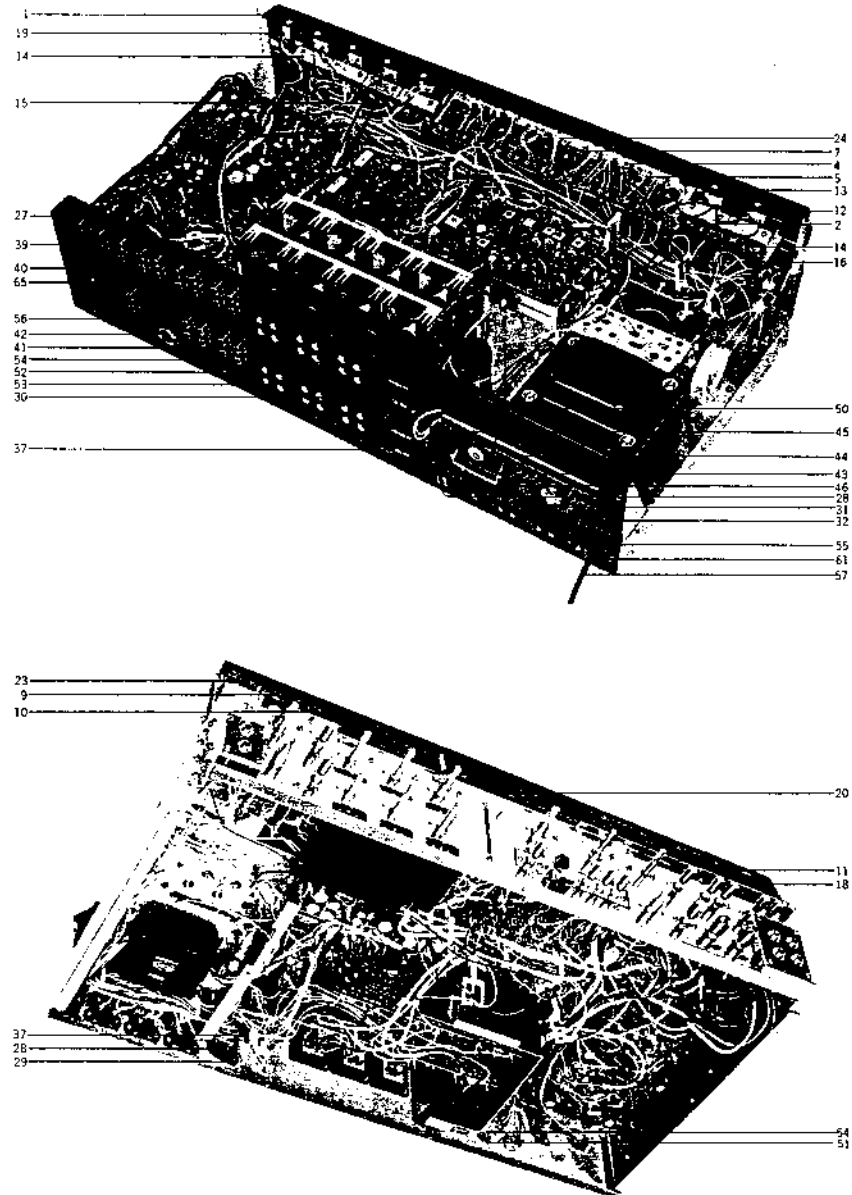

SCALE PLATE/REAR PANEL BLOCK

Ref. No.	Parts No.	Description	Schematic No.	Qty
SCALE MT. CHASSIS BLOCK				
22-1	AZ545218	Scale Mt. Chassis	98-5040	1
22-2	AZ544893	Lamp Case	98-5042	1
22-3x	ZS447772	Tapping Screw #2 3x6 (BR)		10
22-4	AA544904	Lamp Holder, w/prop	98-5043	1
22-5	AA544915	Lamp Holder Case	98-5044	1
22-6x	ZW465287	Tapping Screw #2 3x15 round		2
22-7	EL550045	Cord Lamp #3 8V 50 mA	28-7-30	12
22-8x	SMS31336	Illumination Plate, Pointer	91-5965	1
22-9	EM551248	Signal Meter KL-218L-25	46-1-77	1
22-10	EM551250	Tuning Meter KL-218L-27	46-1-78	1
22-11	EM539706	Level Meter KL-218L-28	46-1-79	4
22-12	AA533384	Meter Mt. Angle	94-5020	3
22-13	ZS371856	ISO Screw, binding head 3x5		7
22-14	AA530820	Meter Case	91-5925	6
22-15	ZS447772	Tapping Screw #2 3x6 (BR)		12
22-16	EJ367986	Fuse Holder 1P AC125V 5A	40-1-8	6
22-17x	EL539684	Fuse Type Lamp 8V 0.3A	28-7-37	11
22-18	EM558044	Indicator (2-4ch)	22-1-31	1
22-19	AA544926	Indicator Support	98-5045	1
22-20	AA544871	Scale Plate B	98-5041	1
22-21x	AA544860	Scale Plate A (T)	98-5041	1
22-22x	AA544882	Scale Plate C (A)	98-5041	1
22-23	EJ556143	Canoe Clip (Large)	7-7-35	2
LAMP P.C. BOARD BLOCK				
22-24	BA560575	Lamp P.C. Board Comp. (98-5001)		1
22-25x	EJ539662	Wrapping Post 1x17	22-1-48	19
22-26x	EJ514822	Fuse Holder, P.C. Board S-N 5051	40-1-28	10
REAR PANEL BLOCK				
22-27	SP544948	Rear Panel A	98-5047	1
22-28	EJ233370	Socket (Volt. Selector) S-18010	40-2-3	1
22-29	ZW552611	ISO Screw, pan head 3x8		2
22-30	ZS570385	ISO Screw, tap-tight 3x8 (pan)		30
22-31	AA510625	SP Antenna Terminal Plate	22-1-29	1
22-32	ZS552611	ISO Screw, pan head 3x8		4
22-33x	ZW348107	ISO NUT M3		5
22-34x	BT444137	Baluns Trans. 75Ω-300Ω	23-1-129	1
22-35x	ZW273778	Earth Lug M3		1
22-36x	ZW273802	Toothed Lock Washer M3		3
22-37	EJ539796	Fuse Holder 2P	40-1-29	2
22-38x	ZS447772	Tapping Screw #2 3x6 (BR)		4
22-39	EJ557875	Wrapping Pin Jack 2P	31-1-113	4
22-40	EJ539763	Wrapping Pin Jack B 4P T5346-B	31-1-105	5
22-41	EJ299305	Jack, 5P Din	31-1-1	1
22-42	ZS447761	Tapping Screw #2 3x6 (BR) (Black)		4
22-43	AA530910	Antenna Channel	91-5928	1
22-44	AA557886	Bar Antenna	25-1-16	1
22-45	AA378268	Antenna Support	AA-5552	1
22-46	ZS379451	ISO Screw, round head 4x50		1
22-47x	ZW273914	Spring Washer M4		2
22-48x	ZW348030	ISO NUT M4		1
22-49x	ZW551373	Washer D4.2x8x0.5t		2
22-50	EZ382263	Strain Relief SR-4K-4	2-7-12	1
22-51	AZ544950	Vol. Mt. Parts	98-5048	2
22-52	EV557897	Vol. V16L4N B1K	34-4-2	1
22-53	ZS552672	ISO Screw, pan head 3x6		4
22-54	EV557943	Co-axial 20throw, Vol.	36-22-13	1
22-55	EJ378944	Socket, AC U/L S-1 9122	31-1-47	3
22-56	EZ486257	Metal Terminal	22-1-27	2
22-57	EWS40112	AC Cord (UL) 2.5M	25-3-15	1
22-58x	EW512485	AC Cord (J) 2.5M	28-3-21	1
22-59x	EW315448	Australia Cord (3 core)	25-3-11	1
22-60x	EW486797	Power Supply Cord (VDE) (WG)	28-3-26	1
22-61	EZ382263	Strain Relief SR-4K-4	2-7-12	1
22-62x	EZ246936	Strain Relief SR-6W-1 (WG, 3 core)	1-7-8	1
22-63x	ER428567	Solid/R. RC1/2 2.2M(K)	35-5-4	1
22-64x	ER430211	Carbon/R. RD1/4 3.9K(J) (Insu. type)	15-5-2	2
22-65	EJ354936	1P Pin-Jack	31-1-22	1

When ordering parts, please describe Parts Number, Serial Number, and Model Number in detail.

FIG. 23 PHOTO OF ASSEMBLY BLOCK

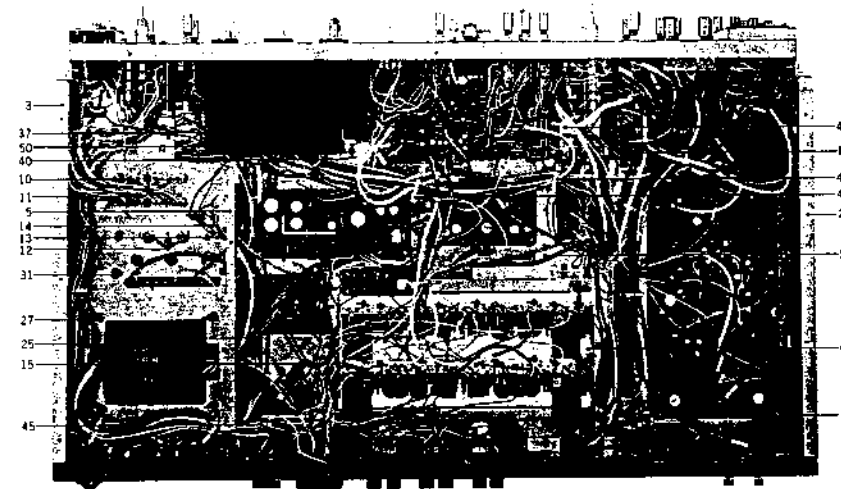
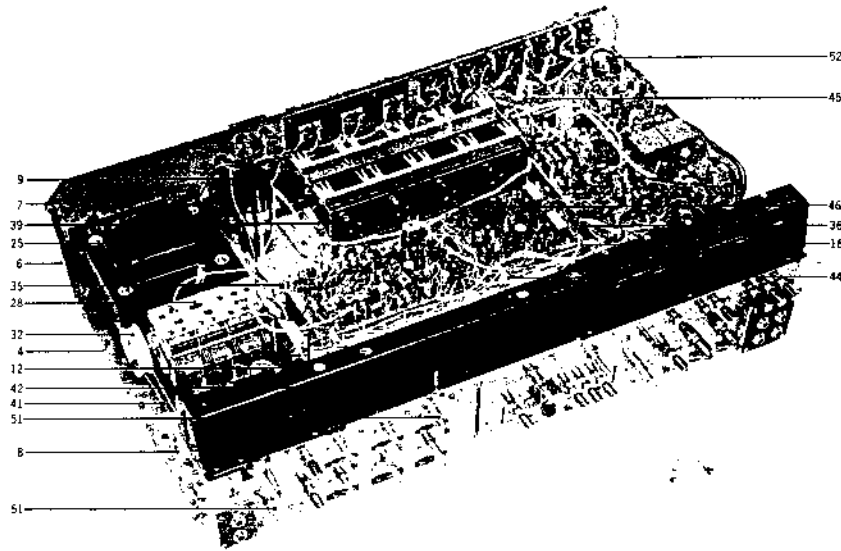

ASSEMBLY BLOCK

Ref. No.	Parts No.	Description	Schematic No.	Qty
23-1	AZ545185	Main Chassis, w/sub chassis	98-5018	1
23-2	AZ545253	Side Plate (Right)	98-5027	1
23-3	AZ545264	Side Plate (Left)	98-5028	1
23-4	Z5447772	Tapping Screw #2 3x6 (BR)		43
23-5	AZ545242	Supporting Plate	98-5026	1
23-6	AZ545130	Supporting Plate A	98-5029	1
23-7	Z5447840	Tapping Screw #2 3x8 (BR)		2
23-8	AZ545152	Roller Base	98-5030	1
23-9	EC557695	Elect./C. 3300µF 80WV (Lug type)	24-10-79	1
23-10	EJ550067	Lug Plate 4P T5305	23-5-5	2
23-11	Z5447805	Tapping Screw #2 3x12 (BR)		2
23-12	EJ539447	Earth Terminal 2P T4460	23-1-N	3
23-13	EJ235023	Lug Plate KP2L1	23-1-C	1
23-14	ER562566	Cement/R. 2W 0.47Ω(K) (wire-wound type)	25-16-1	1
23-15	EJ551035	Wrapping Terminal 4P T5251	23-1-36	4
23-16	AZ545128	P.C. Board Retaining Base	98-5019	1
23-17x	AZ545174	P.C. Board Support A	98-5025	1
23-18x	EJ254970	Lug Plate KP1L1	23-2-1	1
23-19	AZ545196	P.C. Board Support B	98-5024	2
23-20x	AZ545220	P.C. Board Support C (Vol.)	98-5022	1
23-21x	MR530662	Roller B (D=10)	91-5018	2
23-22x	Z5530673	Roller Screw A (L=9)		1
23-23x	AZ545038	Roller Angle	98-5057	4
23-24x	Z5311856	ISO Screw, binding head 3x5		1
23-25	BT557684	Power Trans. AA-98DT-1	24-4-223	1
23-26x	ZW174026	Spring Washer M5		4
23-27	ZW463410	ISO Nut M5 #3		4
23-28	AE550978	Front End FL414U14	57-1-25	1
23-29x	AF444194	FM Front End FL412J19 (I)	57-2-4	1
23-30x	AF444345	FM Front End FL412S13 (A)	57-2-11	1
23-31	ZS311298	ISO Screw, binding head 3x8		4
23-32	MR530706	Pulley	91-5012	1
23-33x	ZS311298	ISO Screw, binding head 3x8		1
23-34x	ZG549011	Tuning Spring	91-5094	1
23-35	AA530627	IF P.C. Board Retaining Plate	91-5025	2
23-36	EJ539447	Earth Terminal 2P T4460	23-1-32	1
23-37	EJ556143	Canopy Clip (Large)	1-7-35	10
23-38x	EJ524700	Canopy Clip	1-7-21	1
23-39	AZ545163	Heat-sink Retaining Plate	98-5081	2
23-40	MZ544937	Tone P.C. Board Support	98-5044	1
23-41	AA207347	Thread		1
23-42	AA530954	Dial Pointer	91-5019	1
23-43	EJ557717	Wire Clip 0017	1-7-36	6
23-44	EJ551057	Wire Clip 220-JD481010-0021	1-7-37	6
23-45	EJ510333	Wire Clip 220-JD481610-0104 (Nylon)	1-7-17	6
23-46	EJ496886	Wire Clip 220-JD486010-119	1-7-16	1
23-47x	EJ514607	Wire Clip 220-JD486210-01 (Nylon)	1-7-18	2
23-48	MZ229138	Wire Bundle Holder N-103	1-35-1	18
23-49	AZ545231	Shield Plate A	98-5022	1
23-50	AZ545040	Tone Insulator Plate	98-5058	1
23-51	AA531371	Stop Collar 2	91-5074	3
23-52	EJ514034	PC Support	1-7-29	32

When ordering parts, please describe Parts Number, Serial Number, and Model Number in detail.

INDEX

Parts No.	Ref. No. & Symbol No.	Parts No.	Ref. No. & Symbol No.	Parts No.	Ref. No. & Symbol No.	Parts No.	Ref. No. & Symbol No.
EO551428	1-T4	ER212681	1-R2	ER306887	4-R79	ER345756	3-R355,56
EO716984	1-L301,2	ER122681	1-R5	ER306887	5-R19	ER345756	4-R11
ER211320	4-R23	ER212681	1-R11,12	ER306887	6-R5	ER345756	4-R12,23
ER211320	4-R26	ER212681	1-R14	ER306887	7-R4	ER345756	4-R150
ER211320	4-R29	ER212681	1-R34	ER306887	7-R4	ER345756	4-R154
ER211320	4-R115	ER212681	2-R10	ER306887	7-R13	ER345756	4-R170
ER211320	4-R142	ER212681	2-R4	ER345756	4-R97	ER345756	4-R174
ER211320	4-R162	ER212681	2-R2	ER345756	4-R13	ER345756	17-R2
ER211320	4-R17	ER212681	1-R7	ER345756	2-R1,13	ER345756	17-R4
ER211465	1-R6	ER212883	1-R42	ER345756	2-R27,28	ER345756	4-R143
		ER212883	2-R20,21	ER345756	4-R17	ER345756	4-R163
ER211465	1-R21,72	ER212883	2-R25,26	ER345756	4-R38	ER361528	6-R2
ER211465	1-R38	ER212883	4-R4,5	ER345756	4-R88	ER361528	11-R18
ER211465	1-R46	ER212883	4-R20	ER345756	4-R52	ER362272	6-R2
ER211465	1-R50,51	ER212883	4-R30,31	ER345756	4-R83	ER362272	7-R6
ER211465	1-R56,57	ER212883	4-R44,65	ER345756	4-R105	ER362441	7-R2
ER211465	2-R8	ER212883	4-R66	ER345756	4-R118	ER364948	3-R251,52
ER211465	2-R14,15	ER212883	4-R92,93	ER345756	4-R121	ER364948	3-R319,20
ER211465	6-R1	ER212883	4-R112	ER345756	6-R14	ER364950	3-R256
ER211465	6-R4	ER212883	5-R9	ER345756	7-R16	ER364950	3-R256
ER211465	6-R17	ER212883	7-R1	ER345756	7-R16	ER364950	3-R256
ER211465	11-R1	ER212883	11-R11	ER345756	7-R16	ER364950	3-R256
ER211465	11-R15	ER212883	18-R3	ER345756	7-R16	ER364950	3-R256
ER211465	11-R21	ER213030	4-R18	ER345756	7-R16	ER364950	3-R256
ER211465	14-R7	ER213030	4-R53	ER345756	7-R16	ER364950	3-R256
ER211465	14-R16	ER213030	4-R84	ER345756	7-R16	ER364950	3-R256
ER211667	1-R1	ER213030	4-R110	ER345756	7-R16	ER364950	3-R256
ER211667	1-R23	ER213030	4-R119,20	ER345756	7-R16	ER364950	3-R256
ER211667	1-R40	ER213030	5-R20	ER345756	7-R16	ER364950	3-R256
ER211667	1-R49	ER213030	6-R15	ER345756	7-R16	ER364950	3-R256
ER211667	1-R52	ER213030	6-R15	ER345756	7-R16	ER364950	3-R256
ER211667	1-R58	ER213467	18-R4	ER345756	7-R16	ER364950	3-R256
ER211667	4-R15	ER213467	3-R115,16	ER345756	7-R16	ER364950	3-R256
ER211667	4-R42	ER213467	3-R133,34	ER345756	7-R16	ER364950	3-R256
ER211667	4-R134	ER213467	3-R233,34	ER345756	7-R16	ER364950	3-R256
ER211667	4-R136	ER213467	3-R233,34	ER345756	7-R16	ER364950	3-R256
ER211667	11-R14	ER213715	3-R109,10	ER345756	7-R16	ER364950	3-R256
ER211667	11-R22	ER213715	3-R123,24	ER345756	7-R16	ER364950	3-R256
ER211757	1-R26	ER213715	3-R241,42	ER345756	7-R16	ER364950	3-R256
ER211757	1-R47	ER213715	3-R260	ER345756	7-R16	ER364950	3-R256
ER211757	4-R22	ER213715	3-R341,42	ER345756	7-R16	ER364950	3-R256
ER211757	4-R41	ER213715	3-R359,60	ER345756	7-R16	ER364950	3-R256
ER211757	4-R47	ER213715	5-R1	ER345756	7-R16	ER364950	3-R256
ER211757	4-R49	ER213715	3-R105,6	ER345756	7-R16	ER364950	3-R256
ER211757	4-R57	ER213715	3-R252	ER345756	7-R16	ER364950	3-R256
ER211757	4-R75	ER213715	3-R133,34	ER345756	7-R16	ER364950	3-R256
ER211757	4-R88	ER213715	3-R339,40	ER345756	7-R16	ER364950	3-R256
ER211757	4-R104	ER214290	3-R117,18	ER345756	7-R16	ER364950	3-R256
ER211757	4-R106	ER214290	3-R207,8	ER345756	7-R16	ER364950	3-R256
ER211757	4-R124	ER214290	3-R231,32	ER345756	7-R16	ER364950	3-R256
ER211757	4-R128,29	ER214290	3-R258	ER345756	7-R16	ER364950	3-R256
ER211757	4-R137,38	ER214290	3-R307,10	ER345756	7-R16	ER364950	3-R256
ER211757	4-R156,57,58	ER214290	3-R351,52	ER345756	7-R16	ER364950	3-R256
ER211757	4-R176	ER214536	3-R131,32	ER345756	7-R16	ER364950	3-R256
ER211757	5-R4	ER214536	3-R235,36	ER345756	7-R16	ER364950	3-R256
ER211757	11-R1	ER214536	3-R235,26	ER345756	7-R16	ER364950	3-R256
ER211757	11-R9	ER229555	3-R156	ER345756	7-R16	ER364950	3-R256
ER211757	11-R12	ER229555	3-R156	ER345756	7-R16	ER364950	3-R256
ER211757	11-R16	ER229555	3-R365	ER345756	7-R16	ER364950	3-R256
ER211757	11-R21	ER230038	3-R367	ER345756	7-R16	ER364950	3-R256
ER211757	14-R1	ER304290	1-R13	ER345756	7-R16	ER364950	3-R256
ER211757	14-R5	ER304290	1-R16,17	ER345756	7-R16	ER364950	3-R256
ER211757	14-R9	ER304290	1-R44	ER345756	7-R16	ER364950	3-R256
ER211757	14-R13	ER304290	1-R48	ER345756	7-R16	ER364950	3-R256
ER211858	1-R24	ER304290	1-R10	ER345756	7-R16	ER364950	3-R256
ER211858	1-R33	ER304402	1-R59	ER345756	7-R16	ER364950	3-R256
ER211858	1-R36	ER304402	4-R139	ER345756	7-R16	ER364950	3-R256
ER211940	6-R3	ER304402	4-R159	ER345756	7-R16	ER364950	3-R256
ER212016	5-R12	ER304402	4-R5	ER345756	7-R16	ER364950	3-R256
ER212016	5-R14	ER306843	1-R8	ER345756	7-R16	ER364950	3-R256
ER212016	5-R16	ER306843	4-R3	ER345756	7-R16	ER364950	3-R256
ER212264	1-R27	ER306843	4-R29	ER345756	7-R16	ER364950	3-R256
ER212264	1-R39	ER306843	4-R63	ER345756	7-R16	ER364950	3-R256
ER212264	4-R6	ER306843	4-R91	ER345756	7-R16	ER364950	3-R256
ER212264	4-R32	ER306843	4-R152	ER345756	7-R16	ER364950	3-R256
ER212264	4-R66	ER306887	1-R3	ER345756	7-R16	ER364950	3-R256
ER212264	4-R94	ER306887	1-R10	ER345756	7-R16	ER364950	3-R256
ER212264	7-R14,15	ER306887	1-R60	ER345756	7-R16	ER364950	3-R256
ER212477	1-R32	ER306887	4-R2	ER345756	7-R16	ER364950	3-R256
ER212477	5-R11	ER306887	4-R37	ER345756	7-R16	ER364950	3-R256
ER212477	6-R9,10	ER306887	4-R71	ER345756	7-R16	ER364950	3-R256
ER306887	4-R79	ER306887	4-R79	ER306887	4-R79	ER306887	4-R79
ER306887	5-R19	ER306887	5-R19	ER306887	5-R19	ER306887	5-R19
ER306887	6-R5	ER306887	6-R5	ER306887	6-R5	ER306887	6-R5
ER306887	7-R4	ER306887	7-R4	ER306887	7-R4	ER306887	7-R4
ER306887	7-R13	ER306887	7-R13	ER306887	7-R13	ER306887	7-R13
ER315213	3-R19,20	ER315213	3-R19,20	ER315213	3-R19,20	ER315213	3-R19,20
ER315213	3-R34,44	ER315213	3-R34,44	ER315213	3-R34,44	ER315213	3-R34,44
ER315213	3-R264	ER315213	3-R264	ER315213	3-R264	ER315213	3-R264
ER315213	3-R317,18	ER315213	3-R317,18	ER315213	3-R317,18	ER315213	3-R317,18
ER315213	3-R333,34	ER315213	3-R333,34	ER315213	3-R333,34	ER315213	3-R333,34
ER324202	11-R8	ER324202	11-R8	ER324202	11-R8	ER324202	11-R8
ER324641	3-R103,4	ER324641	3-R103,4	ER324641	3-R103,4	ER324641	3-R103,4
ER324641	3-R121,21	ER324641	3-R121,21	ER324641	3-R121,21	ER324641	3-R121,21
ER324641	3-R143,46	ER324641	3-R143,46	ER324641	3-R143,46	ER324641	3-R143,46
ER324685	3-R127,28	ER324685	3-R127,28	ER324685	3-R127,28	ER324685	3-R127,28
ER324685	3-R225,26	ER324685	3-R225,26	ER324685	3-R225,26	ER324685	3-R225,26
ER324685	3-R261,62	ER324685	3-R261,62	ER324685	3-R261,62	ER324685	3-R261,62
ER324685	3-R269	ER324685	3-R269	ER324685	3-R269	ER324685	3-R269
ER324685	3-R357,58	ER324685	3-R357,58	ER324685	3-R357,58	ER324685	3-R357,58
ER324720	3-R268	ER324720	3-R268	ER324720	3-R268	ER324720	3-R268
ER324720	3-R313,14	ER324720	3-R313,14	ER324720	3-R313,14	ER324720	3-R313,14
ER324764	3-R171,20	ER324764	3-R171,20	ER324764	3-R171,20	ER324764	3-R171,20
ER324808	3-R266	ER324808	3-R266	ER324808	3-R266	ER324808	3-R266
ER324808	3-R335,36	ER324808	3-R335,36	ER324808	3-R335,36	ER324808	3-R335,36
ER329264	5-R2	ER329264	5-R2	ER329264	5-R2	ER329264	5-R2
ER329308	3-R272	ER329308	3-R272	ER329308	3-R272	ER329308	3-R272
ER329308	3-R305,6	ER329308	3-R305,6	ER329308	3-R305,6	ER329308	3-R305,6
ER329308	3-R331,32	ER329308	3-R331,32	ER329308	3-R331,32	ER329308	3-R331,32
ER329343	3-R129,30	ER329343	3-R129,30	ER329343	3-R129,30	ER329343	3-R129,30
ER345828	7-R3	ER345828	7-R3	ER345828	7-R3	ER345828	7-R3
ER349828	18-R1	ER349828	18-R1	ER349828	18-R1	ER349828	18-R1
ER349828	1-R25	ER349828	1-R25	ER349828	1-R25	ER349828	1-R25
ER349907	1-R29	ER349907	1-R29	ER349907	1-R29	ER349907	1-R29
ER349907	4-R13	ER349907	4-R13	ER349907	4-R13	ER349907	4-R13
ER349907	4-R25	ER349907	4-R25	ER349907	4-R25	ER349907	4-R25
ER349907	4-R26	ER349907	4-R26	ER349907	4-R26	ER349907	4-R26
ER349907	6-R7	ER349907	6-R7	ER349907	6-R7	ER349907	6-R7
ER349907	10-R5,6	ER349907					

SECTION 3
SCHEMATIC DIAGRAM

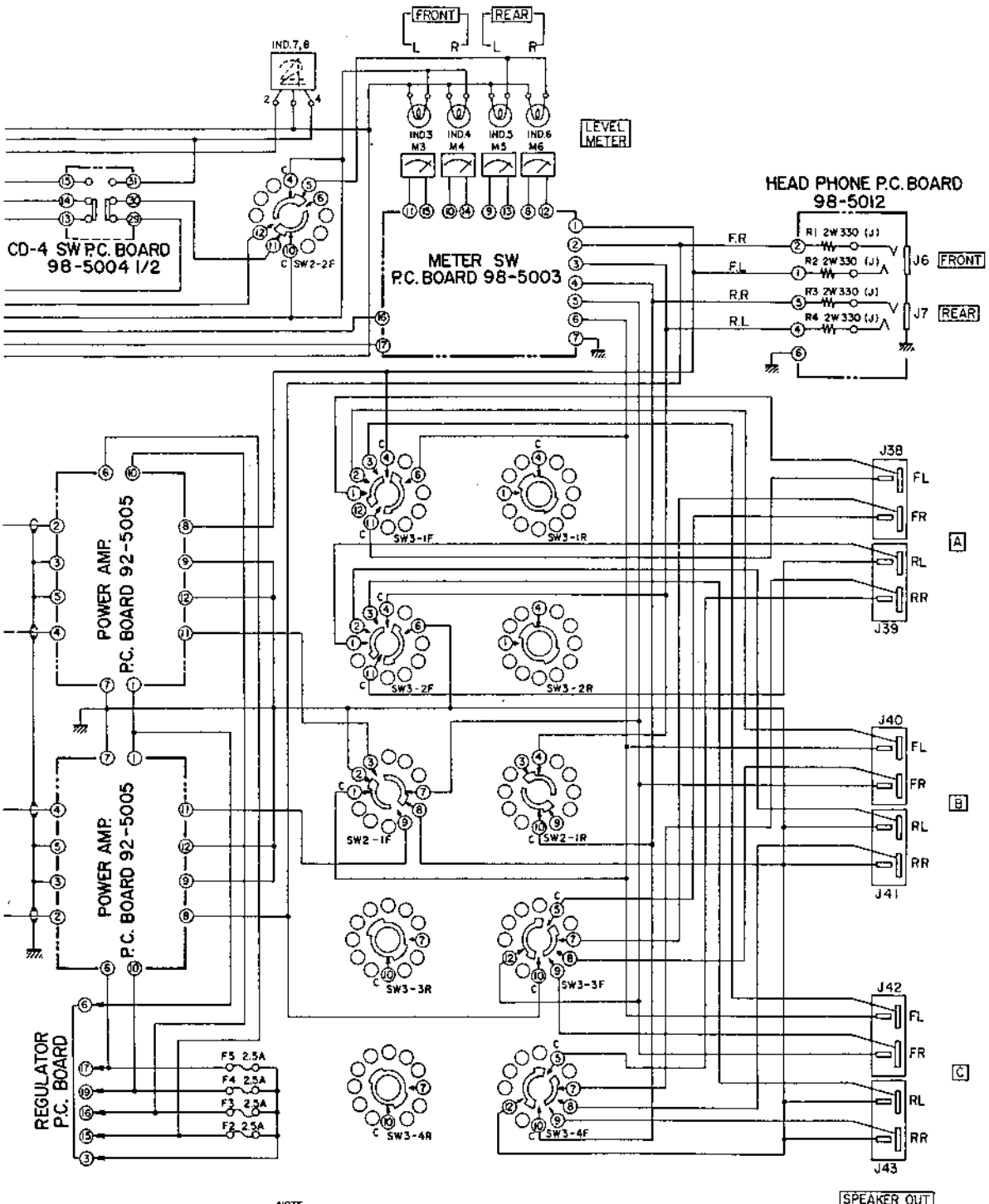

NOTE
 ON ALL MODEL AS-980 AMPLIFIERS MANUFACTURED
 AFTER SERIAL NO 90332-0001 THE WIRING OF
 SPEAKER SELECTOR SWITCH IS CHANGED AS SHOWN IN
 THIS SCHEMATIC DIAGRAM.

AS-980
 SCHEMATIC DIAGRAM
 NO.6-1-b 1480808A

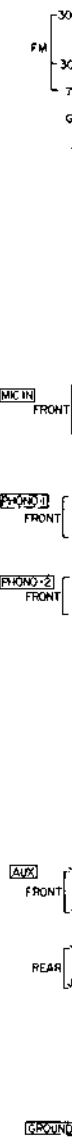

AD PHONE P.C. BOARD
98-5012

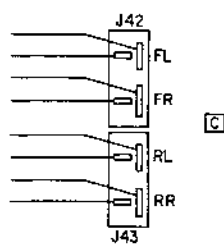
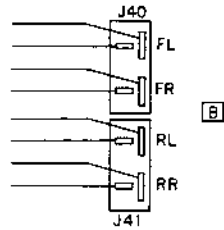
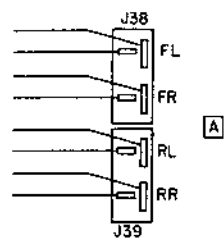
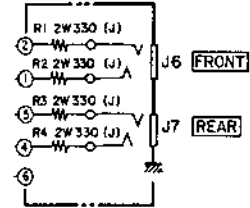

SPEAKER OUT

AS-980
SCHEMATIC DIAGRAM
NO.6-1-b 1480808A

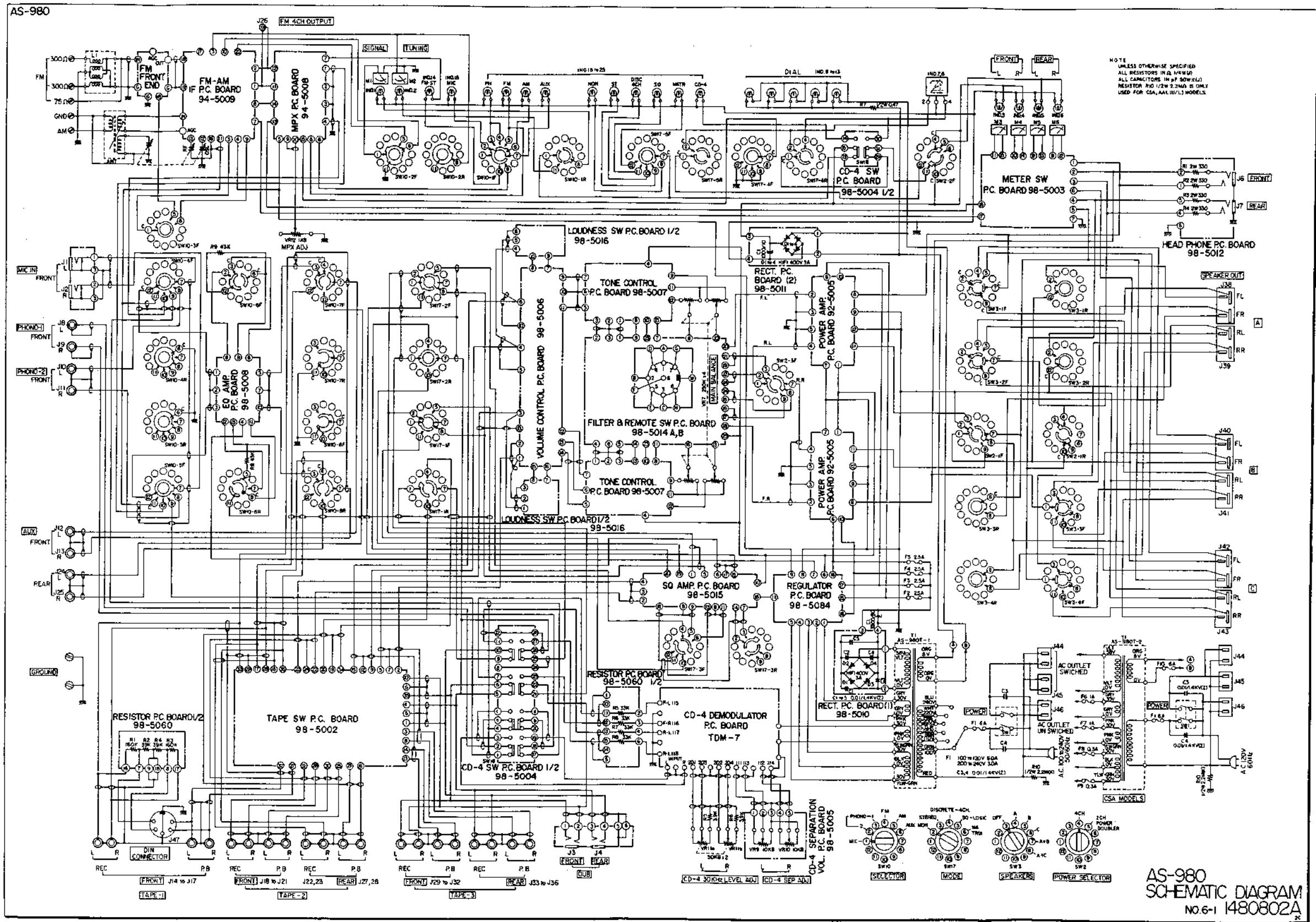

AS-980
SCHEMATIC DIAGRAM
NO.6-1 1480802A

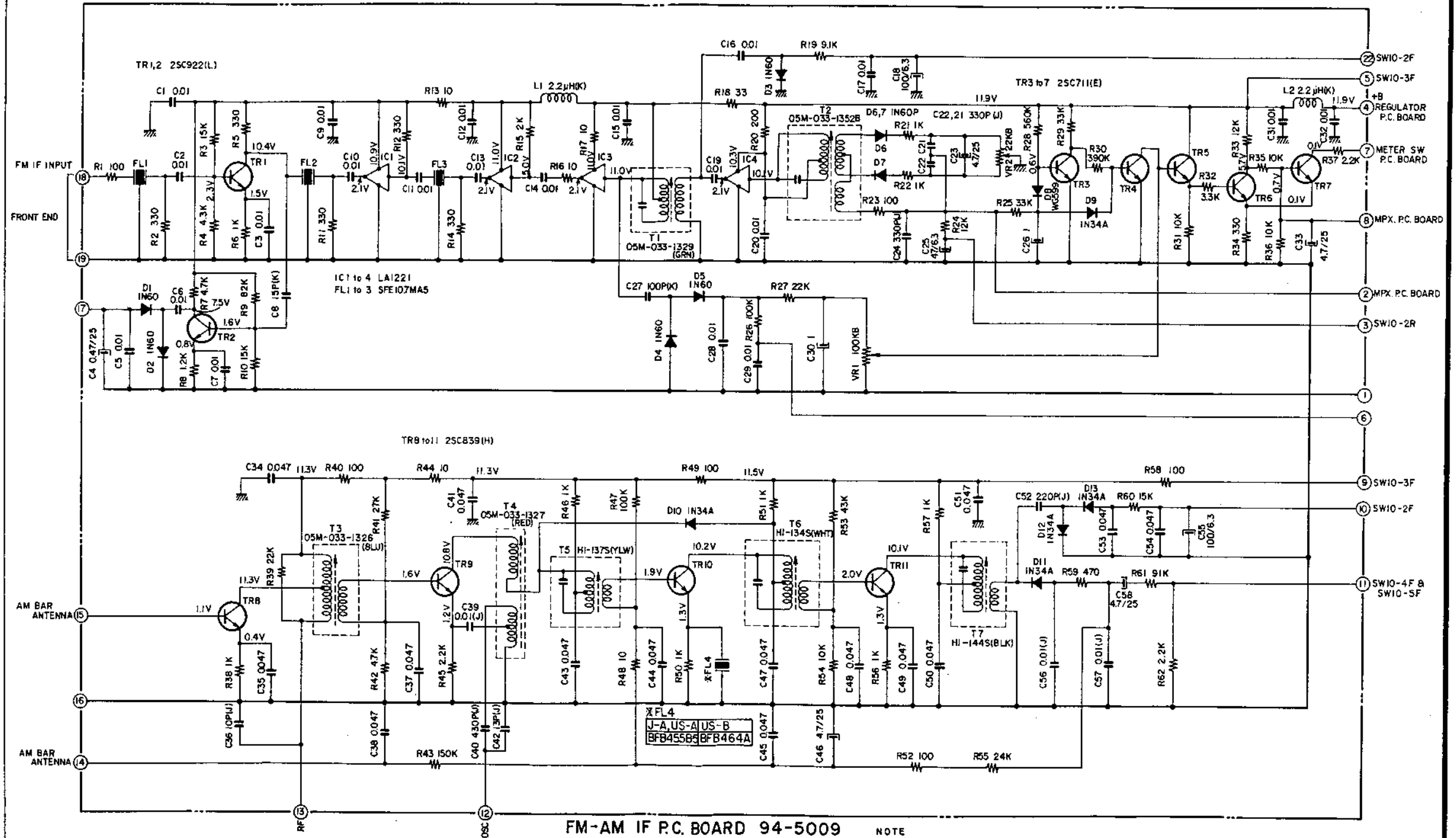

AS-980 FM-AM IF
SCHEMATIC DIAGRAM
NO.6-4 1480805A

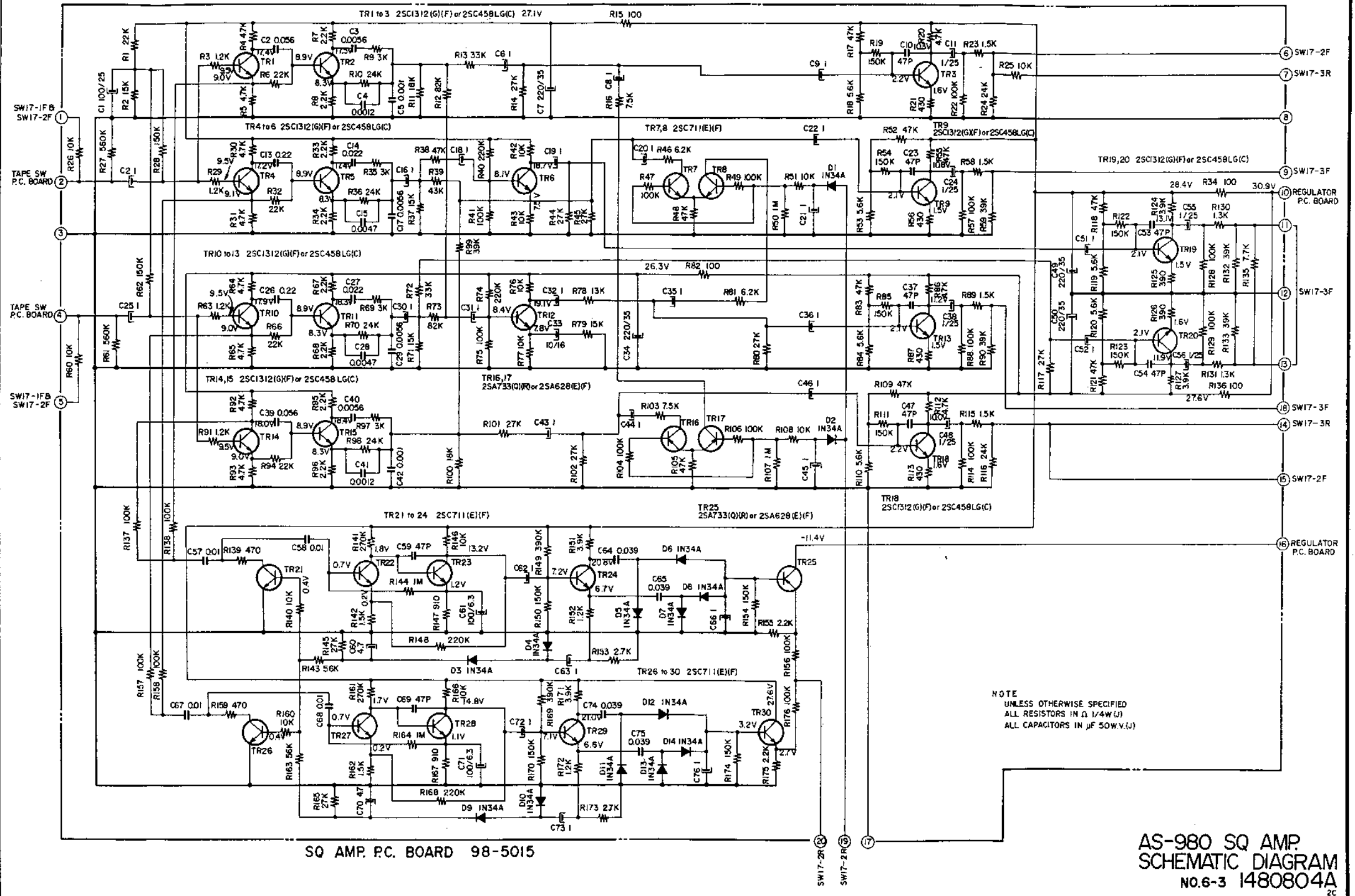

AS-980 SQ AMP.
SCHEMATIC DIAGRAM
NO.6-3 1480804A
2C

AS-980

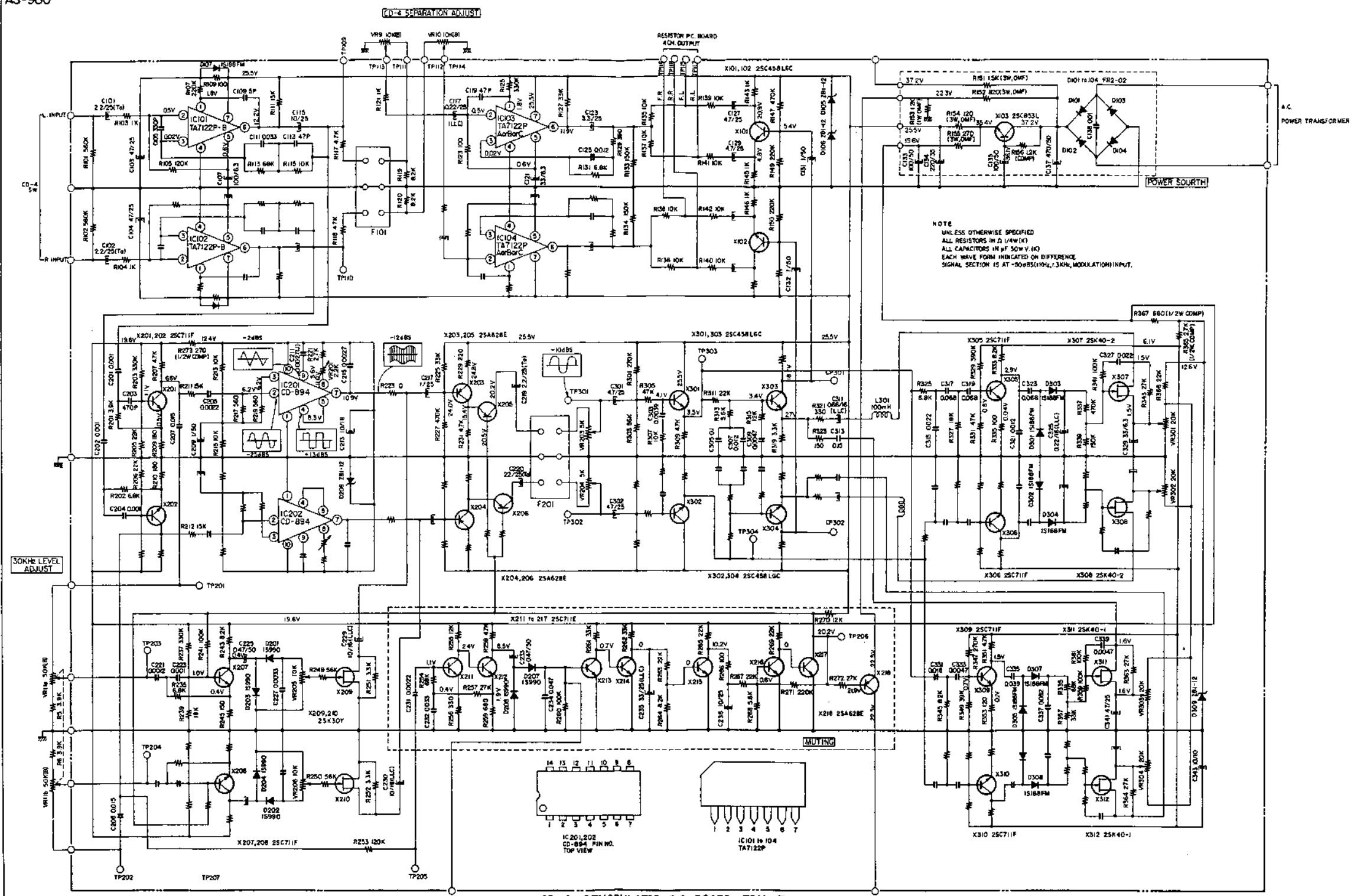

NOTE
 UNLESS OTHERWISE SPECIFIED
 ALL RESISTORS IN Ω / 10^3 (K)
 ALL CAPACITORS IN μ F / 50V (K)
 EACH WAVE FORM INDICATED ON DIFFERENCE
 SIGNAL SECTION IS AT -50dB(100% 1.5KHz MODULATION) INPUT.

CD-4 DEMODULATOR P.C. BOARD TDM-7

AS-980 CD-4 DEMODULATOR
 SCHEMATIC DIAGRAM
 NO.6-2 1480803A

