

# AKAI SERVICE MANUAL

AP-D40/C

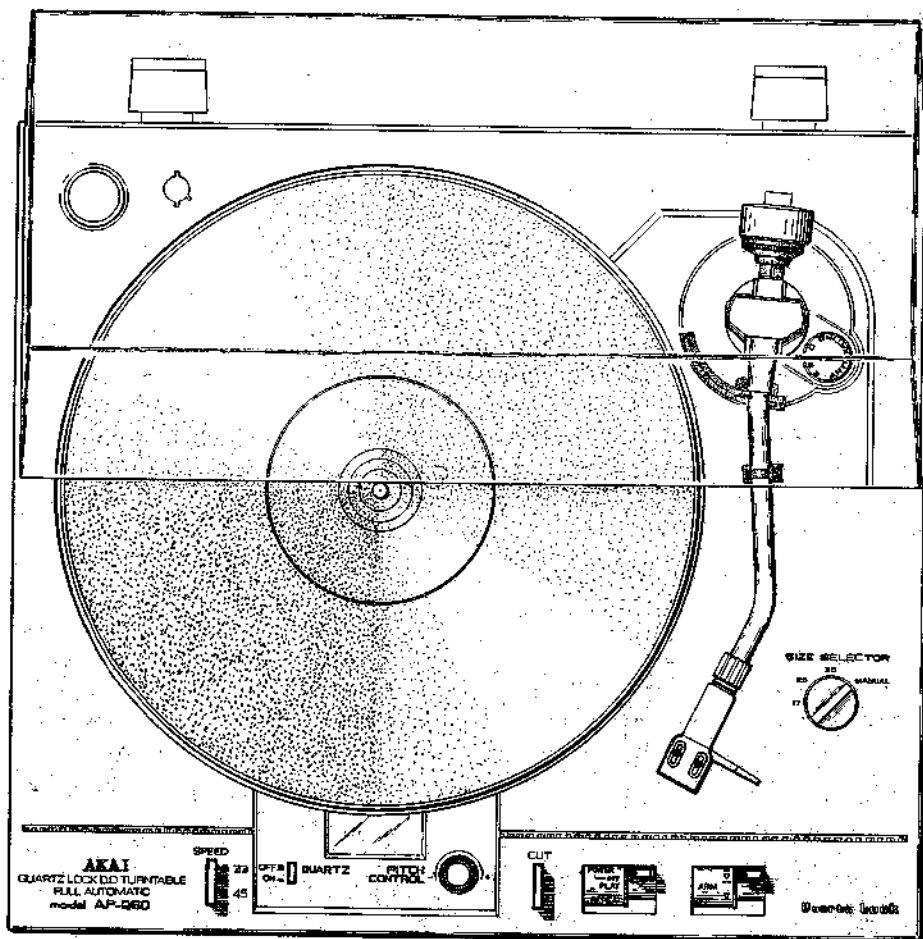

FULL-AUTO DIRECT DRIVE TURNTABLE

MODEL **AP-D40/C**

FULL-AUTO QUARTZ DIRECT DRIVE TURNTABLE

MODEL **AP-Q60/C**



AP-D40/C



AP-Q60/C

**FULL-AUTO DIRECT DRIVE TURNTABLE**

MODEL **AP-D40/C**

**FULL-AUTO QUARTZ DIRECT DRIVE TURNTABLE**

MODEL **AP-Q60/C**

ALSO APPLICABLE TO BLACK PANEL MODEL

SECTION 1	SERVICE MANUAL .....	3
SECTION 2	PARTS LIST .....	39
SECTION 3	SCHEMATIC DIAGRAM .....	59

---

SECTION I

**SERVICE MANUAL**

TABLE OF CONTENTS

<b>I. TECHNICAL DATA</b> .....	<b>4</b>
1. MODEL AP-D40/C .....	4
2. MODEL AP-Q60/C .....	5
<b>II. DISMANTLING OF UNIT</b> .....	<b>6</b>
<b>III. CONTROLS</b> .....	<b>7</b>
1. MODEL AP-D40/C .....	7
2. MODEL AP-Q60/C .....	8
<b>IV. PRINCIPAL PARTS LOCATION</b> .....	<b>9</b>
1. MODEL AP-D40/C .....	9
2. MODEL AP-Q60/C .....	10
<b>V. VOLTAGE AND CICLE CONVERSION</b> .....	<b>11</b>
<b>VI. BLOCK DIAGRAM</b> .....	<b>12</b>
1. MODEL AP-D40/C .....	12
2. MODEL AP-Q60/C .....	12
<b>VII. EXPLANATION OF HOW THE DC BRUSHLESS D.D MOTOR WORKS</b> . . .	<b>13</b>
<b>VIII. EXPLANATION OF HOW THE SERVO CIRCUITRY WORKS</b> .....	<b>15</b>
1. MODEL AP-D40/C .....	15
2. MODEL AP-Q60/C .....	16
<b>IX. MECHANICAL ADJUSTMENT</b> .....	<b>18</b>
1. STYLUS PRESSURE ADJUSTMENT .....	18
2. OVERHANG ADJUSTMENT .....	19
3. ARM LITER ADJUSTMENT .....	20
4. RETURN PLUNGER POSITION ADJUSTMENT .....	21
5. LEAD-IN/LEAD-OUT ADJUSTMENT .....	21
<b>X. ELECTRICAL ADJUSTMENT</b> .....	<b>24</b>
1. MODEL AP-D40/C .....	24
2. MODEL AP-Q60/C .....	25
<b>XI. CLASSIFICATION OF VARIOUS P.C BOARDS</b> .....	<b>27</b>
1. P.C BOARD TITLES AND IDENTIFICATION NUMBER .....	27
2. MODEL AP-D40/C COMPOSITION OF VARIOUS P.C BOARDS .....	28
3. MODEL AP-Q60/C COMPOSITION OF VARIOUS P.C BOARDS .....	31

For basic adjustments, measuring methods, and operating principles, refer to GENERAL TECHNICAL MANUAL.

# I. TECHNICAL DATA

## 1. MODEL AP-D40/C

TURNTABLE	Aluminum alloy diecast (310φ)
DRIVE SYSTEM AND MECHANISM	Direct Drive, Fully Automatic
MOTOR	DC Servo Motor
SPEED AND PITCH CONTROL	33-1/3, 45 rpm ± 5%
WOW AND FLUTTER	0.047% (DIN), 0.033% (JIS)
RUMBLE	45 dB (DIN A), 73 dB (DIN B), 48 dB (JIS)
SPEED ACCURACY	1000 Hz ± 0.12%
TONE ARM	Static Balanced Type
EFFECTIVE ARM LENGTH	220 mm
STYLUS PRESSURE ADJUSTMENT RANGE	0 to 3 grams
APPLICABLE CARTRIDGE WEIGHT	4 to 12 grams (include shell weight)
ARM LIFTER	Oil damped
OVERHANG	15 mm
OFFSET ANGLE	22°30'
HORIZONTAL TRACKING ERROR ANGLE	+3°05', -1°13'
CARTRIDGE	VM Type (Dual Moving Magnet) (Model AP-D40 does not include cartridge)
OUTPUT VOLTAGE	5 mV (DIN 45541)
CHANNEL SEPARATION	More than 20 dB (DIN 45541)
OPTIMUM STYLUS PRESSURE	2 grams
STATIC VERTICAL COMPLIANCE	$17.7 \times 10^{-6}$ cm/dyn
STATIC HORIZONTAL COMPLIANCE	$29.1 \times 10^{-6}$ cm/dyn
ANTI-SKATING ADJUSTER	Spring Tension
POWER REQUIREMENTS	120 V, 60 Hz for Canada and USA 220 V, 50 Hz for Europe except UK 240 V, 50 Hz for UK and Australia 110-120 V/220-240 V, 50/60 Hz internally switchable for the other countries
POWER CONSUMPTION	7 watts
DIMENSIONS	440 (W) × 140 (H) × 403 (D) mm (17.3 × 5.5 × 15.8 inches)
WEIGHT	5.9 kg (13 lbs)

\* For improvement purposes, specifications and design are subject to change without notice.

## 2. MODEL AP-Q60/C

TURNTABLE	Aluminum alloy diecast (310φ)
DRIVE SYSTEM AND MECHANISM	Quartzs Locked Direct Drive, Fully Automatic
MOTOR	DC Servo Motor
SPEED AND PITCH CONTROL	33-1/3, 45 rpm ± 5%
WOW AND FLUTTER	0.047% (DIN), 0.033% (JIS)
RUMBLE	45 dB (DIN A), 70 dB (DIN B), 48 dB (JIS)
SPEED DEVIATION	Less than ± 0.002%
STONE ARM	Static Balanced Type
EFFECTIVE ARM LENGTH	220 mm
STYLUS PRESSURE ADJUSTMENT RANGE	0 to 3 grams
APPLICABLE CARTRIDGE WEIGHT	4 to 12 grams (include shell weight)
ARM LIFTER	Oil Damped
OVERHANG	15 mm
OFFSET ANGLE	22°30'
HORIZONTAL TRACKING ERROR ANGLE	+3°05', -1°13'
CARTRIDGE	VM Type (Dual Moving Magnet) (Model AP-Q60 does not include cartridge)
OUTPUT VOLTAGE	5 mV (DIN 45541)
CHANNEL SEPARATION	More than 20 dB (DIN 45541)
OPTIMUM STYLUS PRESSURE	2 grams
STATIC VERTICAL COMPLIANCE	$17.7 \times 10^{-6}$ cm/dyn
STATIC HORIZONTAL COMPLIANCE	$29.1 \times 10^{-6}$ cm/dyn
ANTI-SKATING ADJUSTER	Spring Tension
POWER REQUIREMENTS	120 V, 60 Hz for Canada and USA 220 V, 50 Hz for Europe except UK 240 V, 50 Hz for UK and Australia 110-120/220-240 V, 50/60 Hz for the other countries
POWER CONSUMPTION	8 watts
DIMENSIONS	440 (W) × 140 (H) × 403 (D) mm (17.3 × 5.5 × 15.8 inches)
WEIGHT	6.1 kg (13.5 lbs)

\* For improvement purposes, specifications and design are subject to change without notice.

## II. DISMANTLING OF UNIT

In case of trouble, etc. necessitating dismantling, please dismantle in the order shown in the photographs. Reassemble in reverse order.

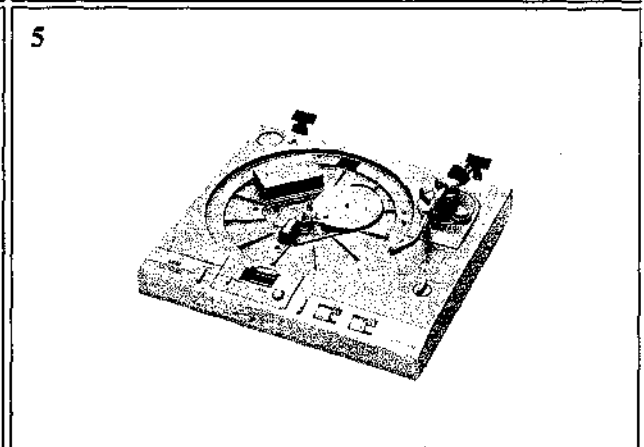
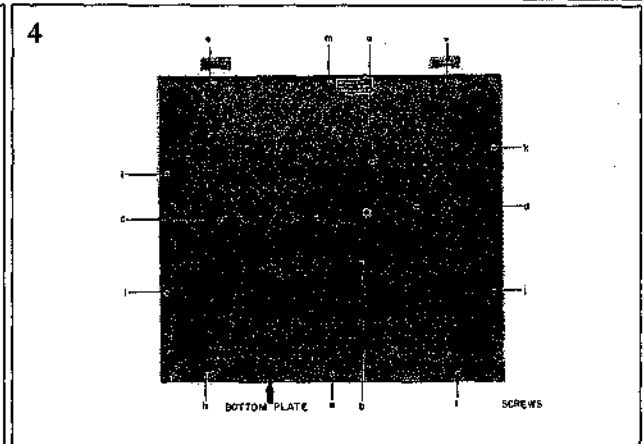
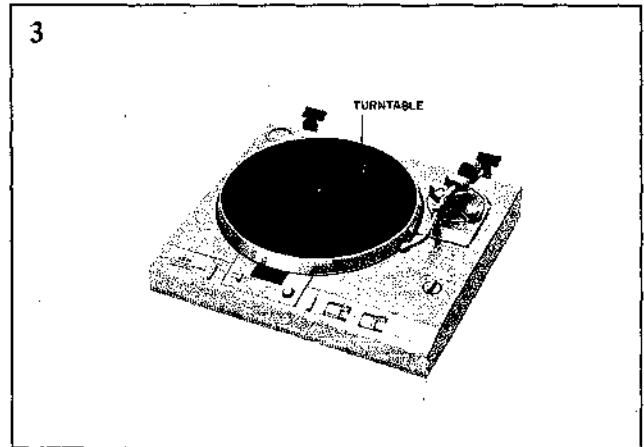
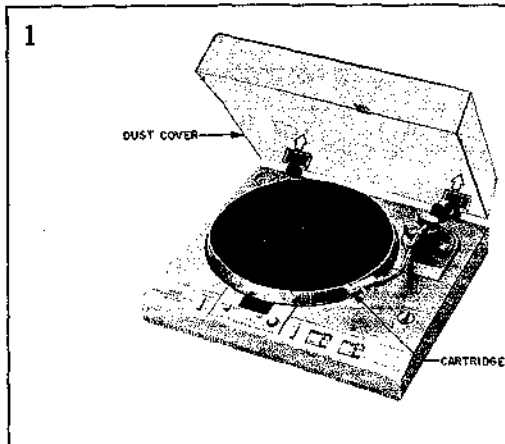

### III. CONTROLS

#### 1. MODEL AP-D40/C

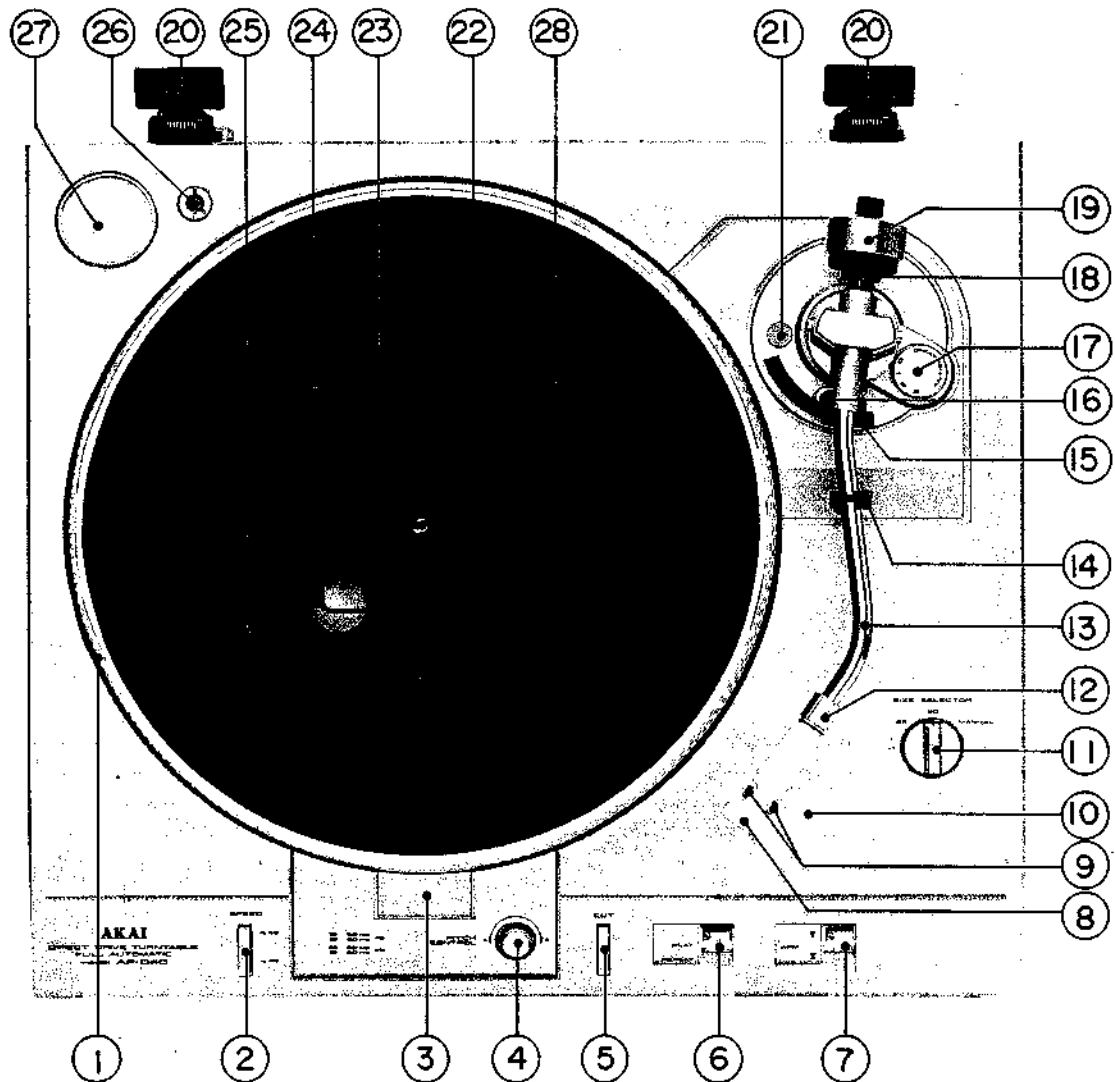

Fig. 1

1. STROBO MARKINGS
2. SPEED SELECTOR SWITCH ( ■ 33 rpm, ▲ 45 rpm)
3. BUILT-IN STROBE LIGHT
4. PITCH CONTROL KNOB
5. RETURN KEY
6. POWER/MODE SELECTOR SWITCH
7. ARM LIFTER SWITCH
8. CARTRIDGE SHELL
9. CARTRIDGE RE-SETTING SCREWS
10. CARTRIDGE SHELL FINGER LEVER
11. SIZE SELECTOR SWITCH
12. LOCKING NUT
13. TONE ARM
14. TONE ARM RESET AND LOCK
15. TONE ARM LIFTER
16. TONE ARM LIFTER ELEVATION ADJUSTMENT SCREW
17. ANTISKATING ADJUSTER
18. STYLUS PRESSURE SCALE RING
19. MAIN WEIGHT
20. HINGES (for Dust Cover)
21. CAP FOR LEAD-IN AND LEAD-OUT ADJUSTMENTS SCREWS
22. SPINDLE
23. OVERHANG ADJUSTMENT GROOVE
24. RUBBER MAT
25. TURNTABLE PLATTER
26. CARTRIDGE SHELL HOLDER
27. 45 rpm ADAPTER HOLDER
28. LEAD-OUT ADJUSTMENT GROOVE

A cartridge is not included with AP-D40.

## 2. MODEL AP-Q60/C

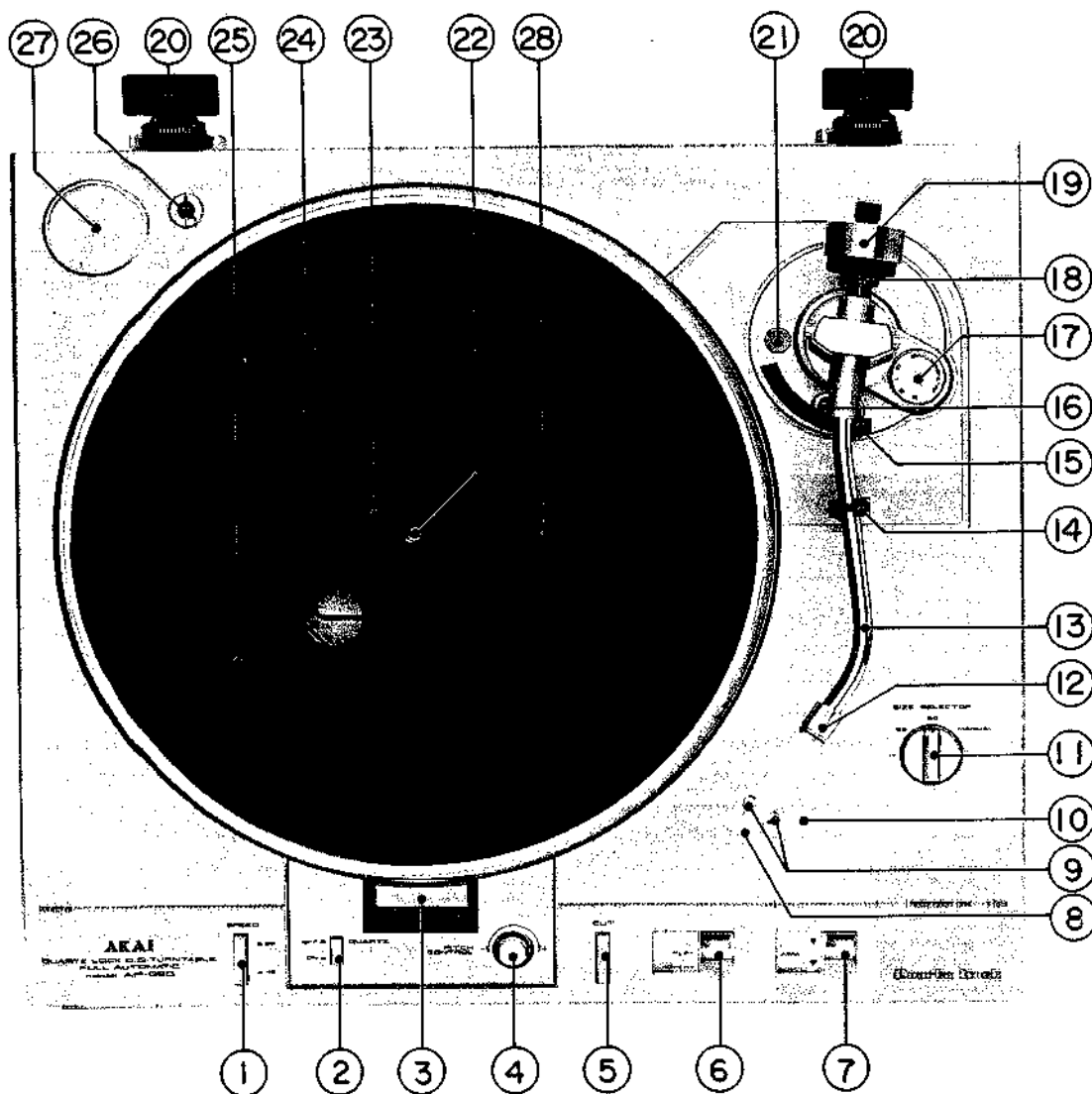

Fig. 2

- |  |   |
|--|---|
| 1. SPEED SELECTOR SWITCH ( ■ 33 rpm, ▴ 45 rpm) | 16. TONE ARM LIFTER ELEVATION ADJUSTMENT SCREW      |
| 2. LOCK-IN QUARTZ SWITCH                       | 17. ANTISKATING ADJUSTER                            |
| 3. STROBE/SPEED DISPLAY                        | 18. STYLUS PRESSURE SCALE RING                      |
| 4. PITCH CONTROL KNOB                          | 19. MAIN WEIGHT                                     |
| 5. RETURN KEY                                  | 20. HINGES (for Dust Cover)                         |
| 6. POWER/MODE SELECTOR SWITCH                  | 21. CAP FOR LEAD-IN AND LEAD-OUT ADJUSTMENTS SCREWS |
| 7. ARM LIFTER SWITCH                           | 22. SPINDLE   |
| 8. CARTRIDGE SHELL                             | 23. OVERHANG ADJUSTMENT GROOVE                      |
| 9. CARTRIDGE RE-SETTING SCREWS                 | 24. RUBBER MAT                                      |
| 10. CARTRIDGE SHELL FINGER LEVER               | 25. TURNTABLE PLATTER                               |
| 11. SIZE SELECTOR SWITCH                       | 26. CARTRIDGE SHELL HOLDER                          |
| 12. LOCKING NUT                                | 27. 45 rpm ADAPTER HOLDER                           |
| 13. TONE ARM                                   | 28. LEAD-OUT ADJUSTMENT GROOVE                      |
| 14. TONE ARM REST AND LOCK                     |   |
| 15. TONE ARM LIFTER                            |   |

A cartridge is not included with AP-Q60.



# IV. PRINCIPAL PARTS LOCATION

## 1. MODEL AP-D40/C

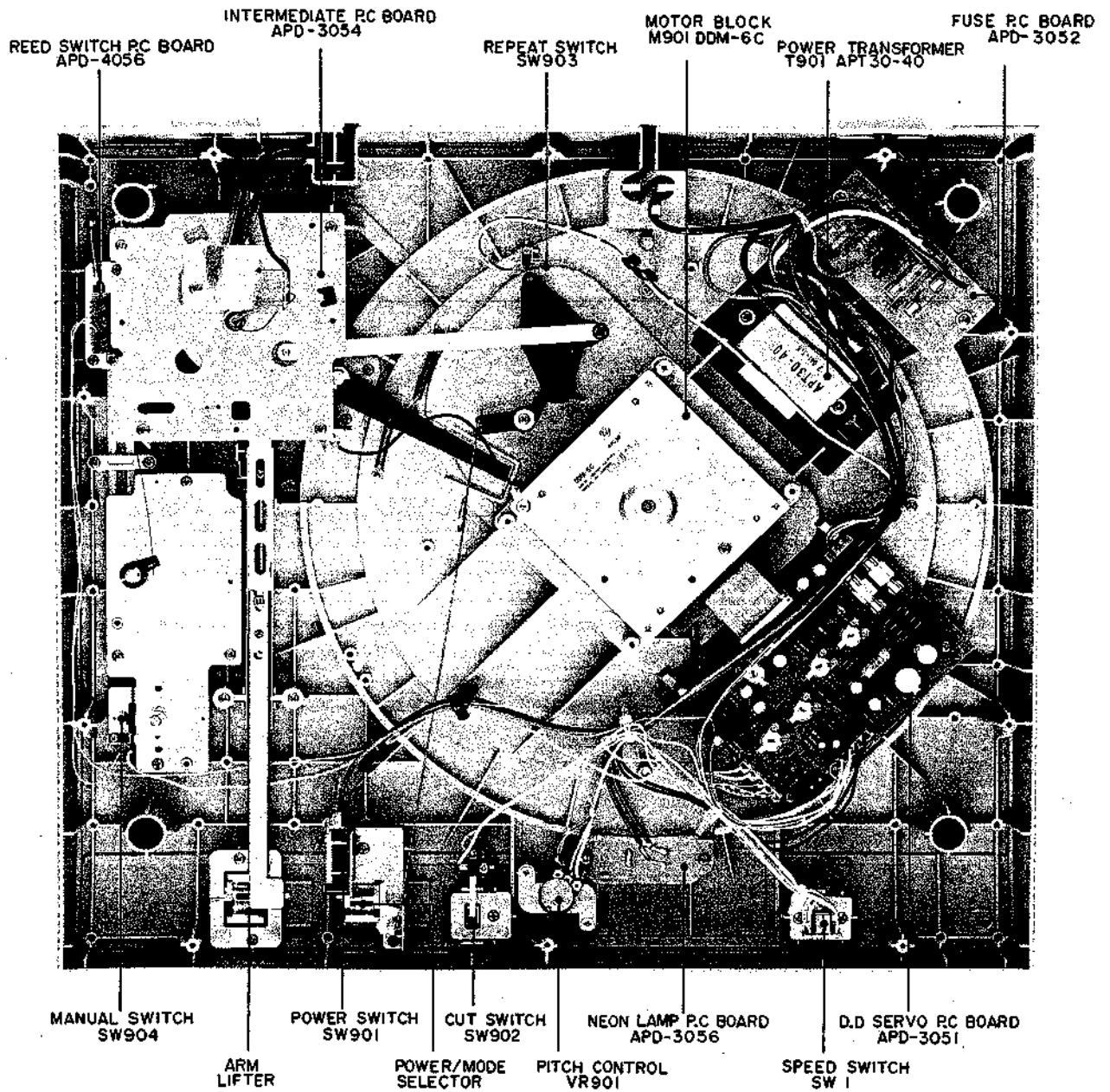

Fig. 3 Bottom View

2. MODEL AP-Q60/C

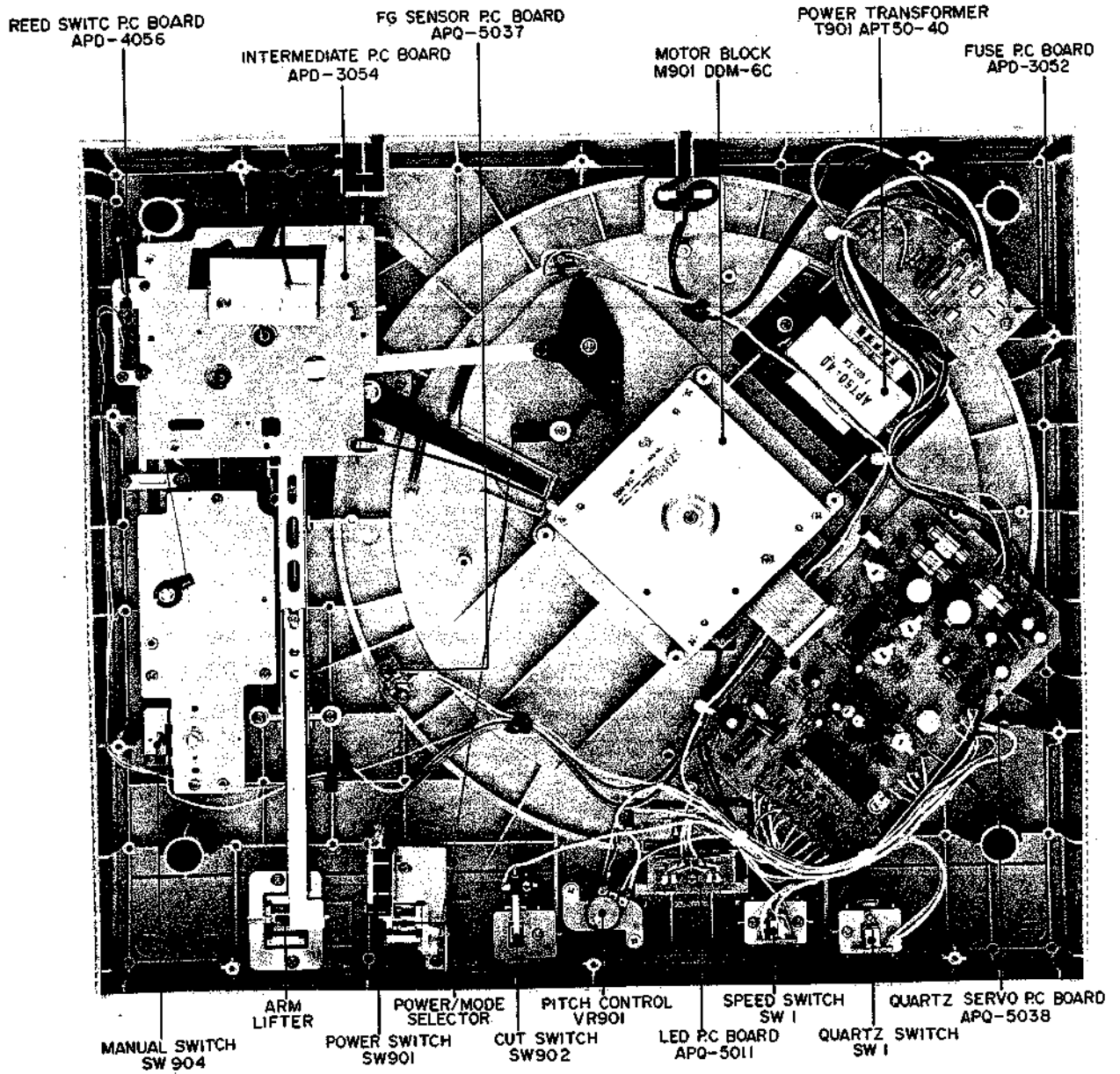
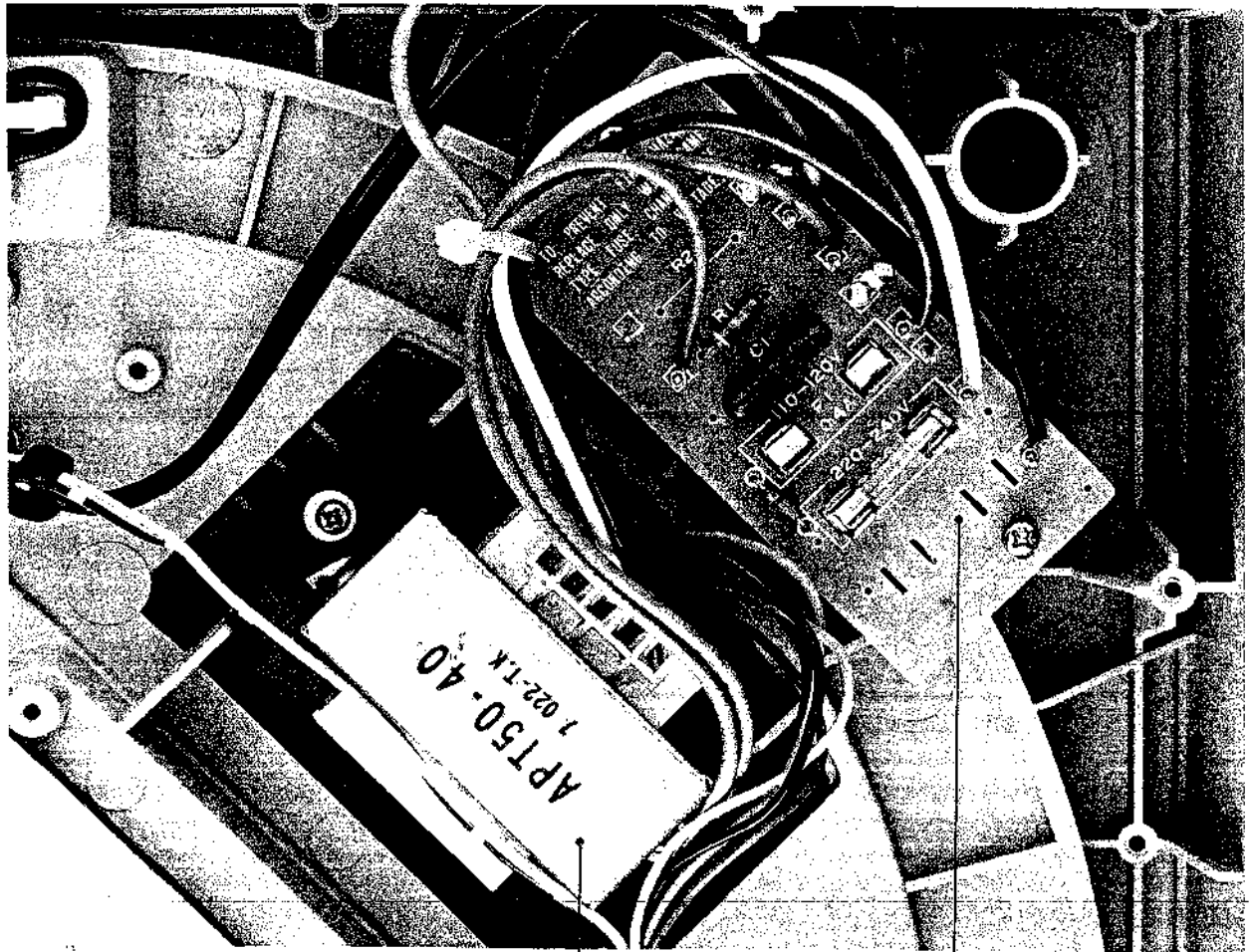

Fig. 4 Bottom View

## V. VOLTAGE AND CYCLE CONVERSION



POWER TRANSFORMER

FUSE PC BOARD  
110-120V: F1 0.4A  
220-240V: F2 0.4A

Fig. 5 VOLTAGE CONVERSION (U/T only)

### 1. VOLTAGE CONVERSION

Models for Canada, USA, Australia and Europe are not equipped with this facility. This machine can be set to 110 - 120V/220 - 240V as required.

Each machine is preset at the factory according to destination but if voltage change is necessary it can be accomplished as follows only by qualified personnel.

1. Disconnect power supply cord.
2. Remove the bottom cover.
3. Remove existing Line Voltage Fuse and insert required Line Voltage Fuse in the proper fuse holder according to the printed instructions.

### 2. CYCLE CONVERSION

With DC servo motor, cycle conversion is not necessary.

# VI. BLOCK DIAGRAM

## 1. MODEL AP-D40/C

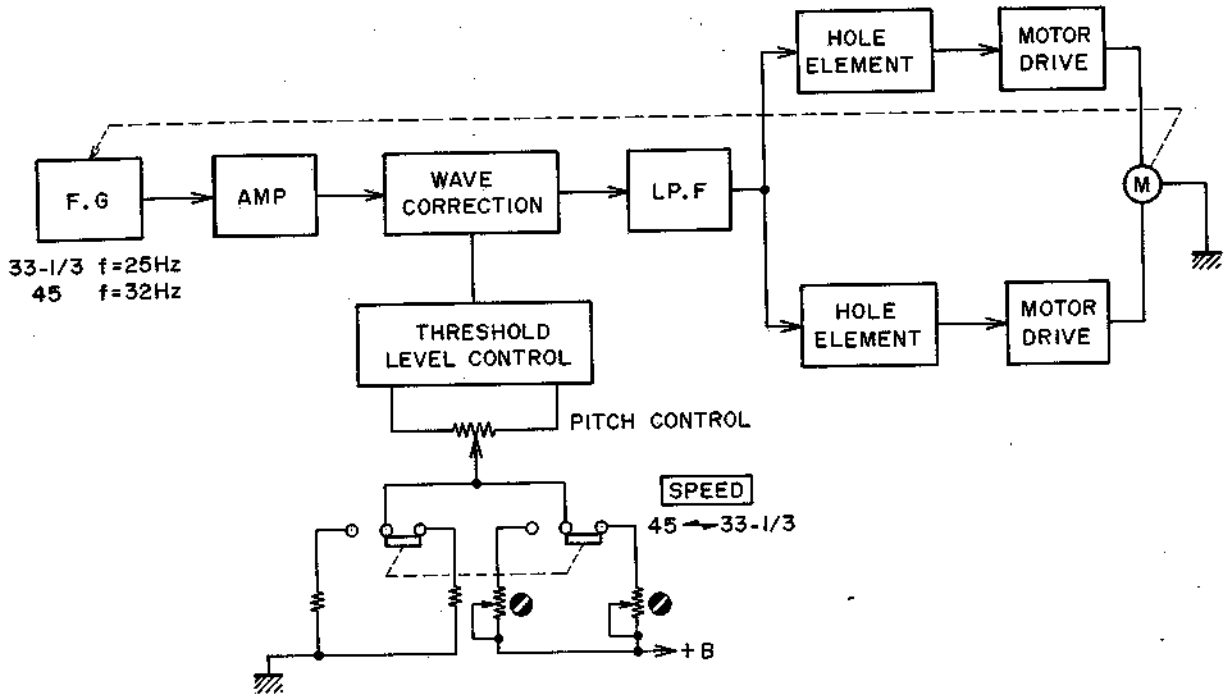

Fig. 6

## 2. MODEL AP-Q60/C

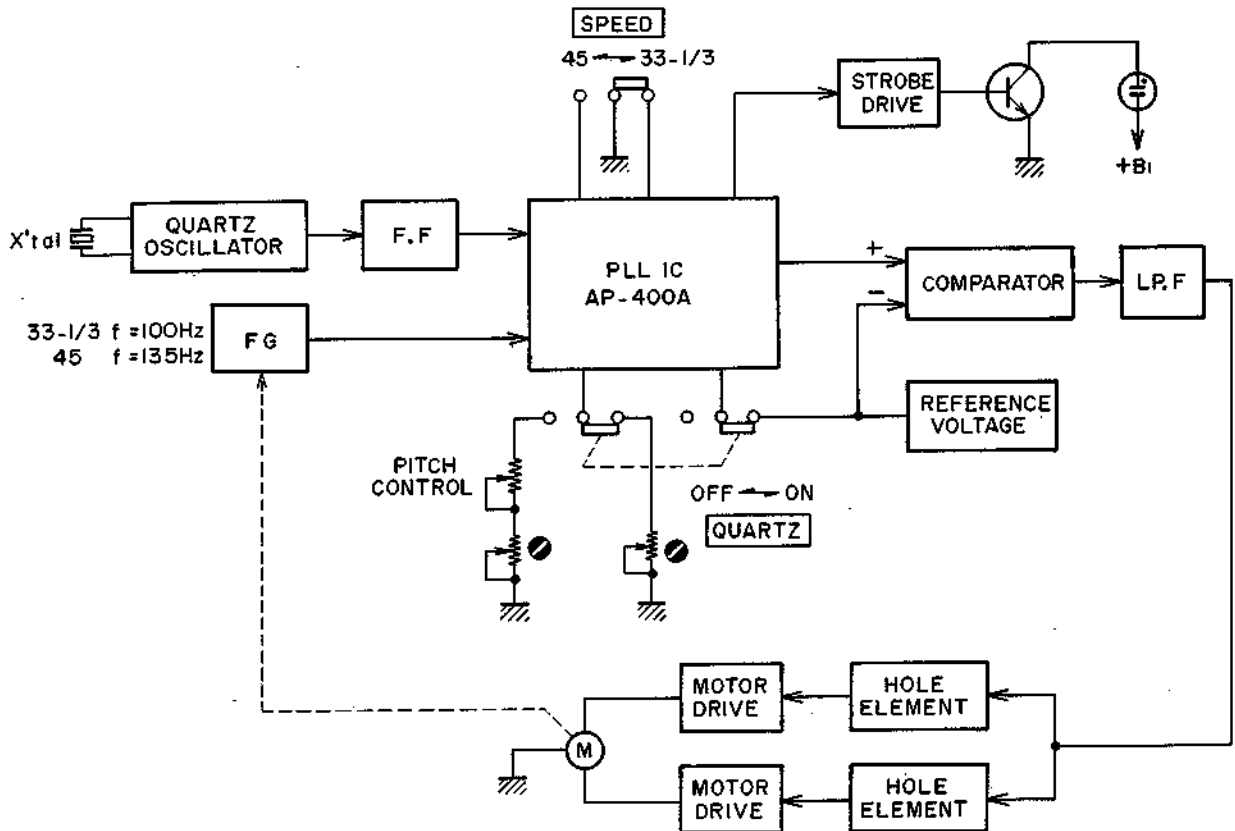

Fig. 7

# VII. EXPLANATION OF HOW THE DC BRUSHLESS D.D MOTOR WORKS

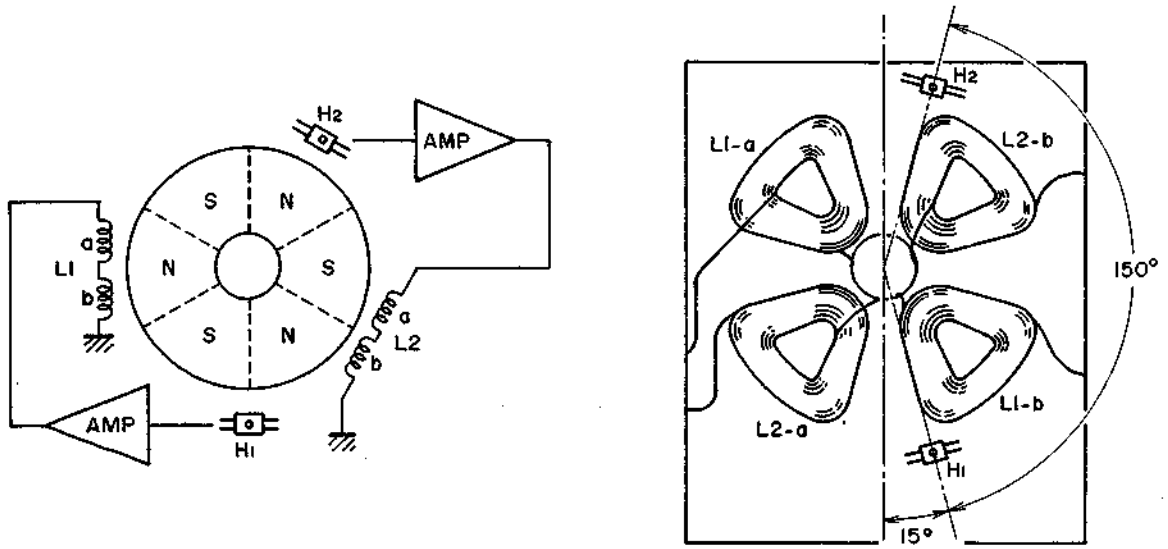

Fig. 8 Relative Positions of the Coils, Magnet and Hall Elements

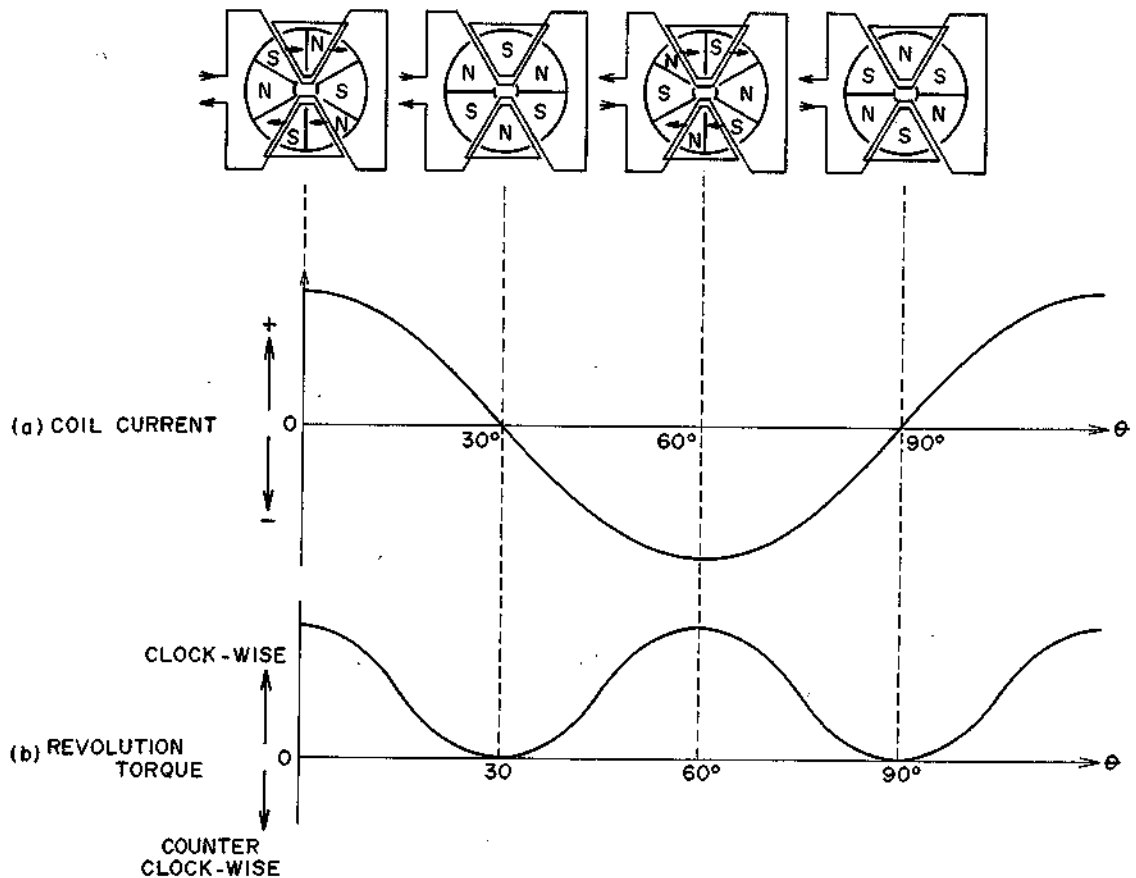

Fig. 9 Revolution Torque vs Magnet Polarity Position at one Phase

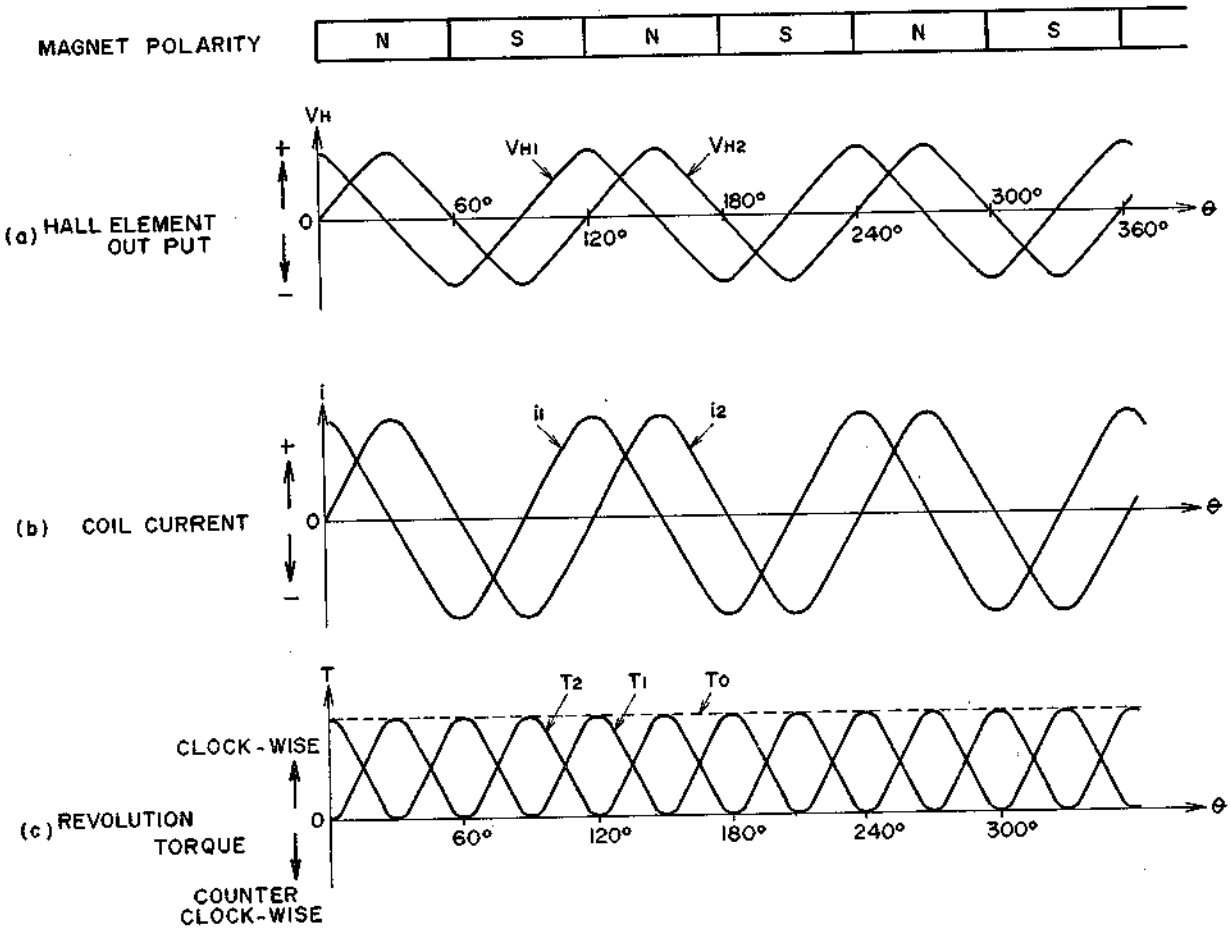

Fig. 10 Each Output Waveform vs Position of Magnetic Polarity

Fig. 8 shows the 4 coils and the 2 Hall elements on the base board. Fig. 8 (a) shows the motor drive system and the magnet which face the coils. The magnet is magnetized into 6 poles arranged alternately N/S.

Changes in the sine wave's magnetic field which accompanies revolution of the magnet are detected by the Hall elements, amplified by an amplifier generating torque which is supplied to the coil and then the magnet revolves. When sine wave current flows into the coil, with  $\theta$  as the revolution angle and  $K$  as a fixed value, the torque force  $T_1$  is:

$$T_1 = K \cdot i_1 \sin 3\theta \dots\dots\dots (1)$$

the coil current  $i_1$  with  $I$  as a fixed value is:

$$i_1 = I \cdot \sin 3\theta \dots\dots\dots (2)$$

so from 1 and 2:

$$T_1 = K \cdot I \cdot \sin^2 3\theta \dots\dots\dots (3)$$

Fig. 9 shows the changes in the coil current  $i_1$  and the torque  $T_1$  accompanying changes in the revolution angle

$\theta$ . A clockwise revolution torque is produced. Also the coil's other phase is out  $90^\circ$  electrically. As the phase of the magnetic field detected by the Hall element is also  $90^\circ$  out, the current flowing to this coil is:

$$i_2 = I \cdot \cos 3\theta \dots\dots\dots (4)$$

the generated torque  $T_2$  is

$$T_2 = K \cdot i_2 \cos 3\theta \dots\dots\dots (5)$$

so from 4 and 5:

$$T_2 = K \cdot I \cdot \cos^2 3\theta \dots\dots\dots (6)$$

Fig. 10 shows the relationship between the output from the two Hall elements, current  $i_1$  and  $i_2$ , and the generated torque  $T_1$  and  $T_2$ .

The total torque generated is the sum of torques  $T_1$  and  $T_2$ . This torque  $T_0$  is

$$T_0 = T_1 + T_2 = K \cdot I (\sin^2 3\theta + \cos^2 3\theta) = K \cdot I$$

As shown in Fig. 10.  $T_0$  is fixed regardless of the revolution angle  $\theta$ .

# VIII. EXPLANATION OF HOW THE SERVO CIRCUITRY WORKS

## 1. MODEL AP-D40/C (Refer to the schematic diagram.)

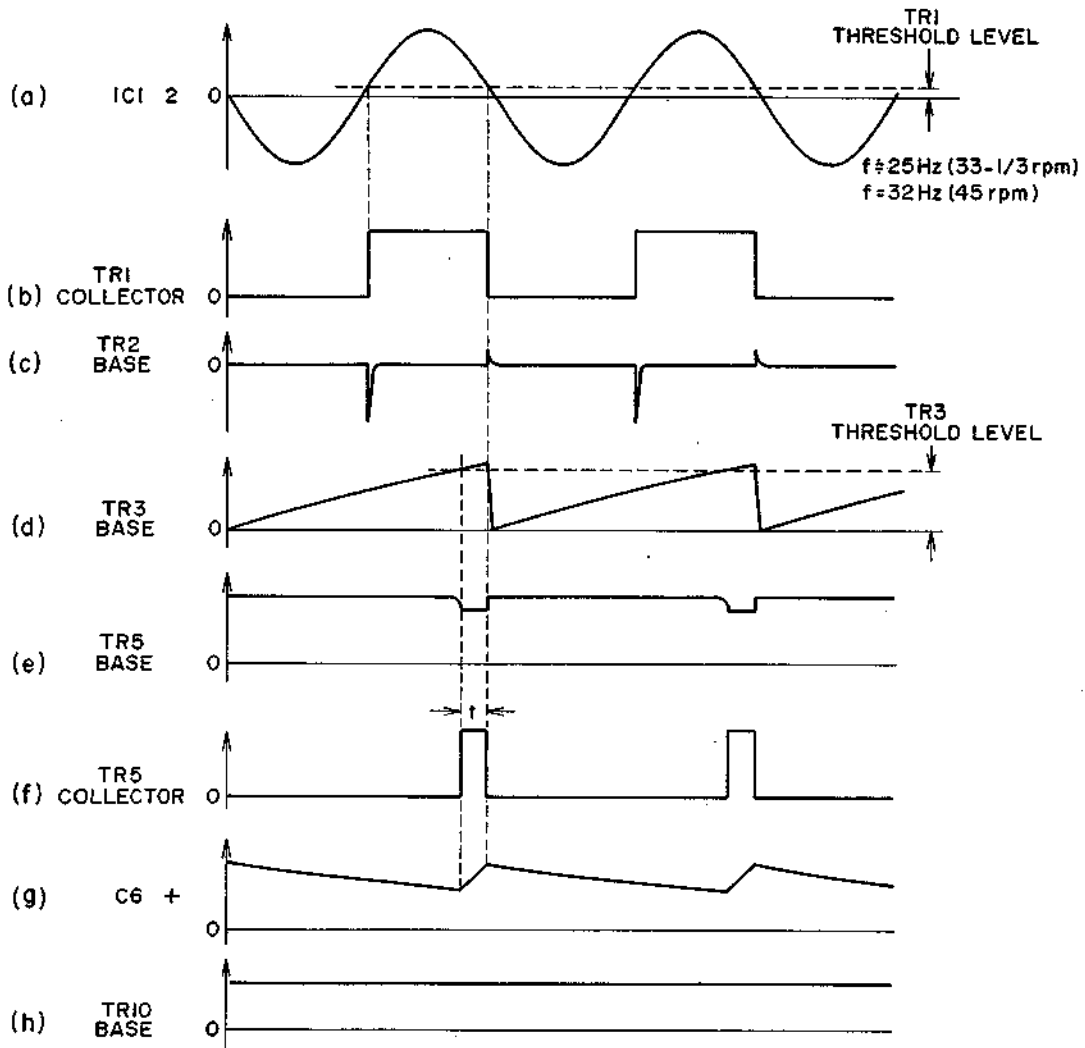

Fig. 11

The FG signal obtained from the motor block print coil is amplified by IC1 and added to TR1's base. When the FG signal passes TR1's threshold level. TR1 goes on and waveform (b) appears in the collector. Differentiated by C4 and R7, the positive pulse of the differential signal turns on TR2. As a result the integral waveform of waveform (d), with C5's current curve, appears in TR3's base. TR5 only goes on once the threshold level of waveform (d) has been passed and then waveform (f) appears in TR5's collector. The voltage of C6's two terminals is as with the waveform (g). This is because current flows in C6 during the period of waveform (f) only, regardless. This signal (waveform g) passes IC1's low pass filter, makes a DC control signal and becomes TR10's bias voltage. As a result, collector current flows into TR10 and control current into the Hall elements H1 and H2.

When the speed is faster than fixed, the period of FG signal shortens and the pulse width  $t$  decreases. Consequently waveform (g)'s voltage drops as does the base bias of TR10. Then the current to the Hall elements is reduced, the motor torque is weakened and the speed slows down, or in other words the speed of revolution is maintained at a fixed rate. When the speed slows, the period of FG signal lengthens and the pulse width  $t$  increases. Then the current in the Hall elements is increased, and the motor torque strengthened. In this way, the speed is controlled at a fixed rate. Pitch control is the changing of TR3's emitter potential by the changes of TR4's base bias. As a result, the threshold level of waveform (d) is raised and the pulse width changed. In this way, the Hall element current can be controlled and the speed changed.

## 2. MODEL AP-Q60/C (Refer to the schematic diagram.)

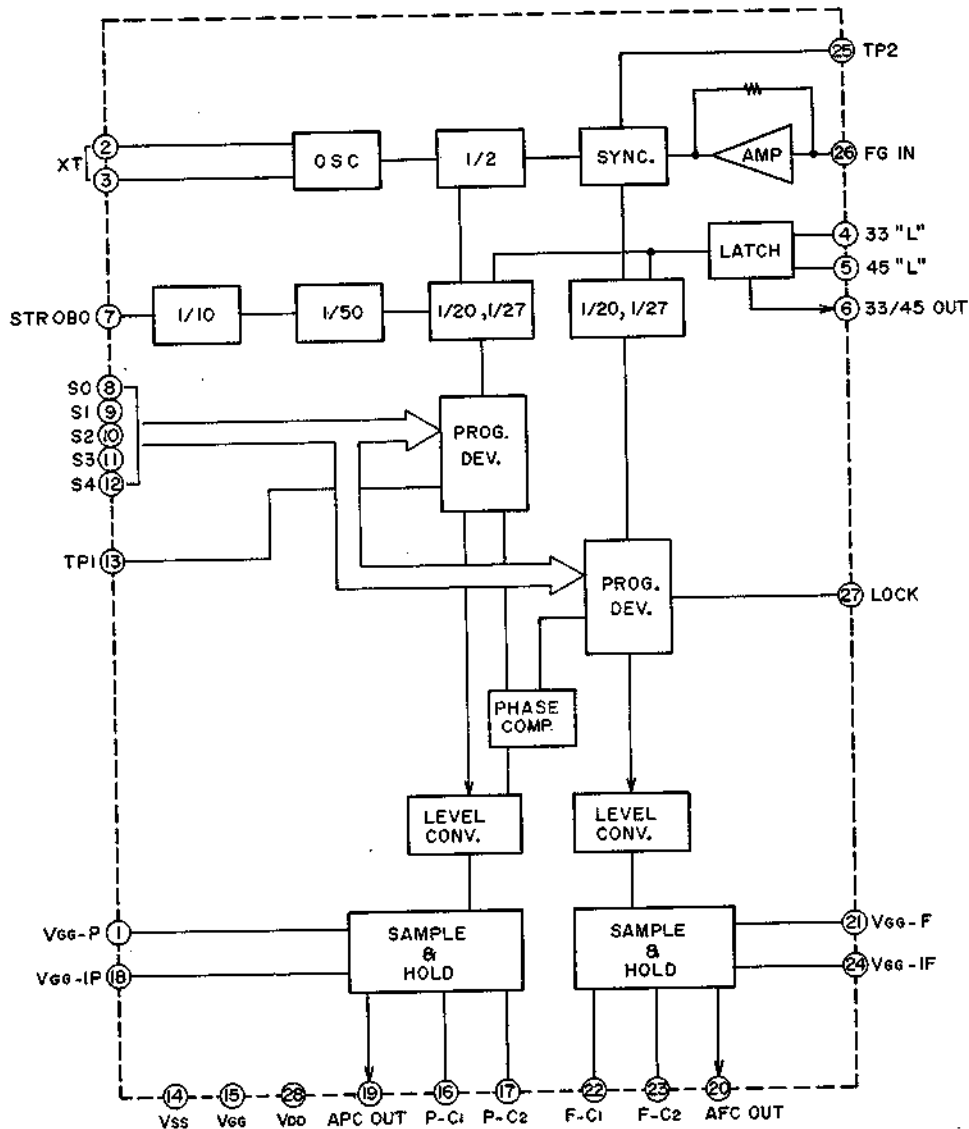

Fig. 12

The AP-Q60 has a photo sensor which picks up the FG signal from the stroboscope pattern on the underside of the platter in order to detect the speed. The servo circuit also employs PLL LSI AP-400A for motor control and it is a quartz lock system. AP-400A is an N channel silicon gate MOS type LSI which has been developed for speed control of quartz lock DD motors.

In Fig. 12's block diagram and Chart 1, the relationship between the terminal signal and operation mode is shown. AP-400A outputs voltage proportionate to the number of revolutions (AFC-OUT), and voltage proportionate to the phase (APC-OUT).

The FG signal input from the FG sensor enters the base of TR2, is rectified and then enters AP-400A's FG IN terminal. Next there is a 5.4 MHz oscillation by C1 and the X'tal (5.4 MHz) which is scaled down to 1/2 by the T-Flip Flop. This scaled down signal of

2.7 MHz is the standard frequency and is input into AP-400A's XT terminal.

A voltage proportionate to the number of revolutions is put out from AFC-OUT and another voltage proportionate to the phase appears in APC-OUT due to AP-400A. When the quartz lock is on, these AFC-OUT and APC-OUT voltages are compared and amplified. Next they pass a low pass filter and are made into a DC control signal of the TR6's base bias. As a result, the collector current flows and the Hall element current is controlled.

When the quartz lock is off, a standard voltage from R26 and R27 and the AFC-OUT voltage are compared and amplified and the Hall element current is controlled. Pitch control controls the speed, changing the AFC-OUT voltage by changing the VGG-F addition voltage.



Name	Terminal No.	Operation Mode
V <sub>GG-P</sub>	1	Supply terminal giving a high level of output voltage for APC-OUT.
XT	2,3	Terminal connecting 2.7 MHz X'tal at FG = 180 pulses/1 revolution.
33 IN 45 IN	4 5	Terminal selecting the speed, has built-in pull up resistors becoming active at "L" level.
33/45 OUT	6	Becomes "L" level when set to 33-1/3 rpm.
STROBE	7	Strobe signal output terminal and duty is 1/10. Output frequency is the same as that of the input pulse FG-IN from the motor when the speed is accurate.
S <sub>0</sub> ~ S <sub>4</sub>	8 ~ 12	Input signal terminal for minute adjustment. 32 step speed control possible in steps of 0.2% by 5 bit binary code.
TP1	13	Test point at APC sampling signal output terminal.
V <sub>SS</sub>	14	GND terminal.
V <sub>GG</sub>	15	Supply terminal 12V <sup>+1V</sup> <sub>-2V</sub>
P-C <sub>1</sub>	16	Terminal for condenser connection to generate APC circuit saw waves.
P-C <sub>2</sub>	17	Terminal for condenser correction to store APC sampling voltage.
V <sub>GG-IP</sub>	18	Terminal to control APC circuit saw wave tilt.
APC-OUT	19	APC output voltage terminal.
AFC-OUT	20	AFC output voltage terminal.
V <sub>GG-F</sub>	21	Supply terminal giving a high level of output voltage for AFC-OUT.
F-C <sub>1</sub>	22	Terminal for condenser connection to generate AFC circuit saw waves.
F-C <sub>2</sub>	23	Terminal for condenser connection to store AFC sampling voltage.
V <sub>GG-IF</sub>	24	Terminal to control AFC circuit saw wave tilt.
TP2	25	Test point at AFC sampling signal output terminal.
FG-IN	26	Terminal inputting pulses to correspond to motor speed.
LOCK	27	Outputs "L" level when the motor is PLL locked. Inside is an open in MOS FET and the LEDs can be directly driven.
V <sub>DD</sub>	28	Supply terminal 5V ± 0.5V.

Chart-1

# IX. MECHANICAL ADJUSTMENT

## 1. STYLUS PRESSURE ADJUSTMENT

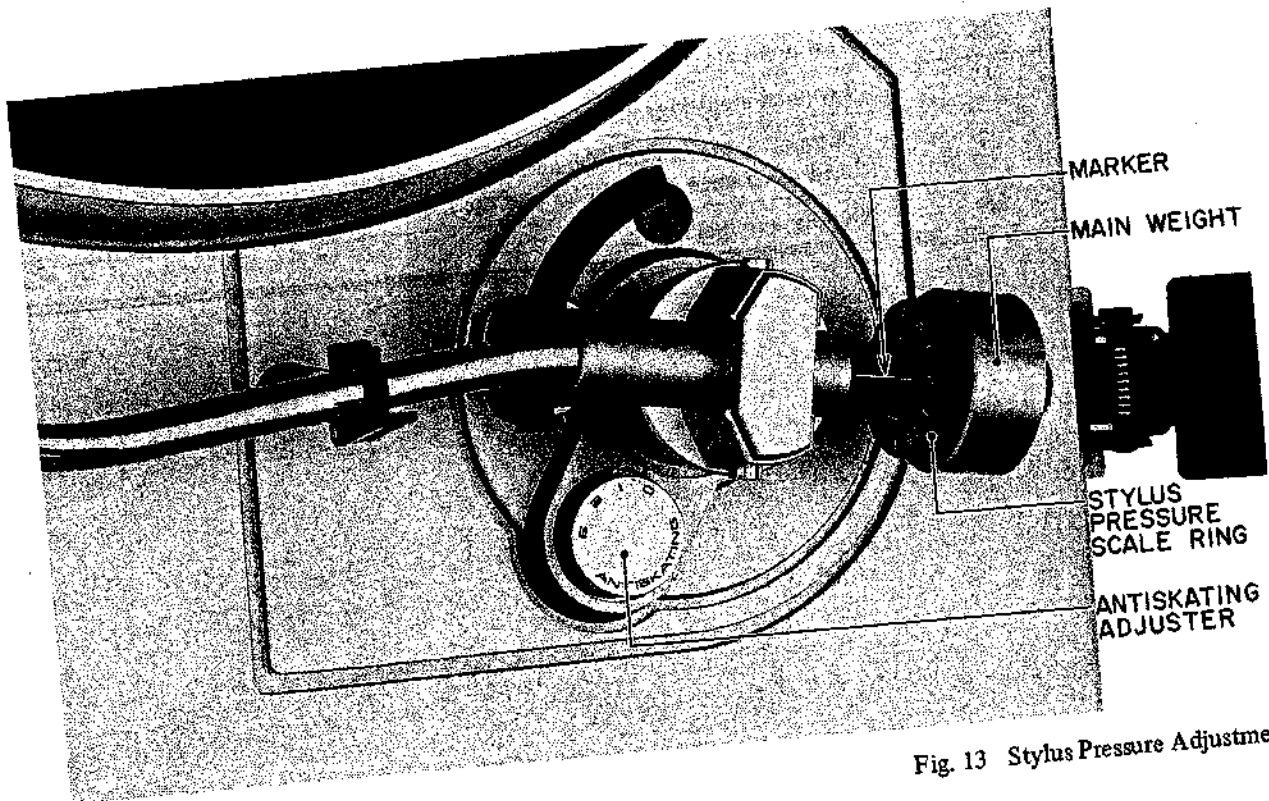

Fig. 13 Stylus Pressure Adjustment

1. Disconnect the Power Cord.
2. Set the Tone Arm Lifter switch to  $\nabla$ .
3. Bring the Tone Arm to a position between the turntable and the Tone Arm Rest without touching either.
4. Rotate Main Weight backwards and forwards until the Tone Arm is in perfect horizontal balance. (Zero balance is attained.)

- CAUTION**
1. Be sure that Anti-skating Adjuster is set to zero.
  2. Remove the stylus guard and be careful not to damage the stylus.
5. Without moving the Main Weight, turn only the Stylus Pressure Scale Ring to match the "0" mark with the marker on the weight shaft. (Refer to Fig. 13)

6. Turn Main Weight counter-clockwise (as viewed from the front) with the Stylus Pressure Scale Ring until the marker on the weight shaft corresponds to the desired stylus pressure on the scale.

- NOTE**
1. AP-D40, AP-Q60 Black and Silver Panel Models do not come equipped with Cartridges.
  2. The recommended stylus pressure for the supplied stylus (AP-D40C, AP-Q60C only), RS-90 is 2 grams. However, in the case of outside interference, more pressure may be needed for stability. The range of adjustment is from 0 to 3 grams.
7. Set the Anti-skating adjuster to correspond with the stylus pressure. (Fine adjust if necessary.)

## 2. OVERHANG ADJUSTMENT

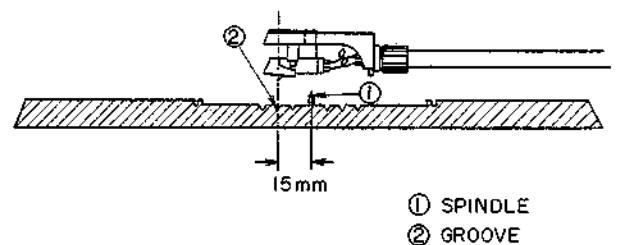
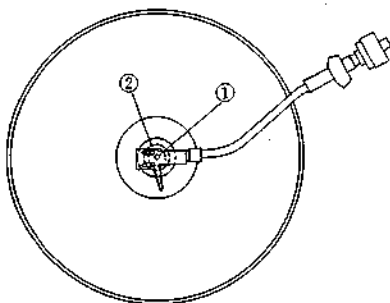

Fig. 14 Overhang Adjustment

The distance from the turntable shaft to the stylus when the Tone Arm is at the center of the turntable is called overhang. Although overhang is preset at the factory for this model, when the cartridge is replaced, adjustment may be necessary. For your convenience, the rubber turntable mat has an indicator groove at the center for easy overhang adjustment.

Bring the Tone Arm to the center of the turntable. Adjust the cartridge position in the cartridge shell so that the stylus position is even with the middle groove ring at overhang adjustment position. The cartridge position is adjustable by resetting the screws of the cartridge shell.

### 3. ARM LIFTER ADJUSTMENT

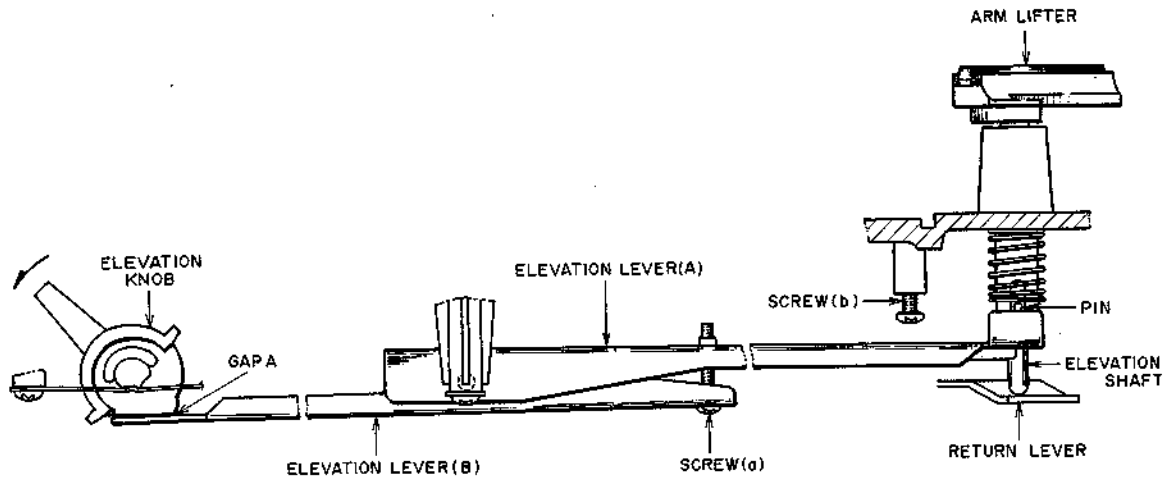

Fig. 15

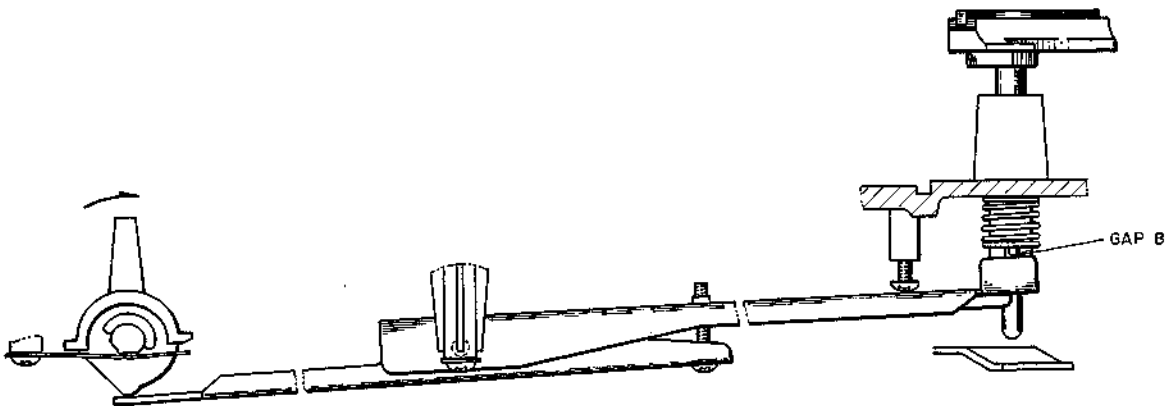

Fig. 16

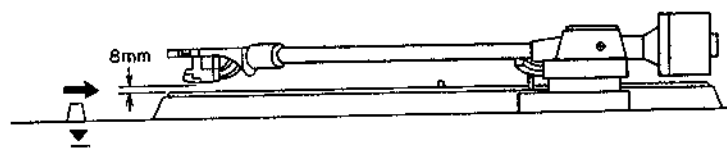

Fig. 17

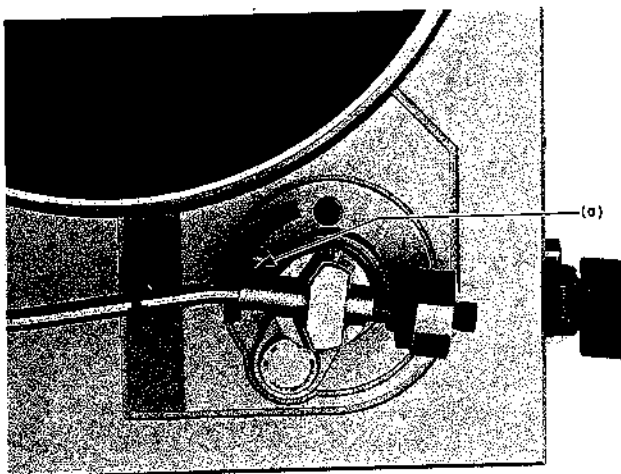

Fig. 18

1. Adjust with the elevation control and the arm lifter should be down. Confirm that the elevation shaft and lifter lever are touching. If not, press the arm lifter down with one finger until they do. Adjust screw (a) at exactly the point where the gap A between the elevation lever (B) and the elevation control disappears. (Refer to Fig. 15).
2. Next operate the auto return (turn the main gear by hand) and raise the arm lifter. With the elevation control at  $\nabla$ , adjust screw (b) at exactly the point where the gap (B) between the shaft pin and the elevation lever (A) disappears. (Refer to Fig. 16).
3. Put a record on and set the elevation control to  $\nabla$ . Adjust screw (a) until there is an 8 mm gap between the tip of the stylus and the surface of the record. (Refer to Figs. 17, 18)

#### 4. RETURN PLUNGER POSITION ADJUSTMENT

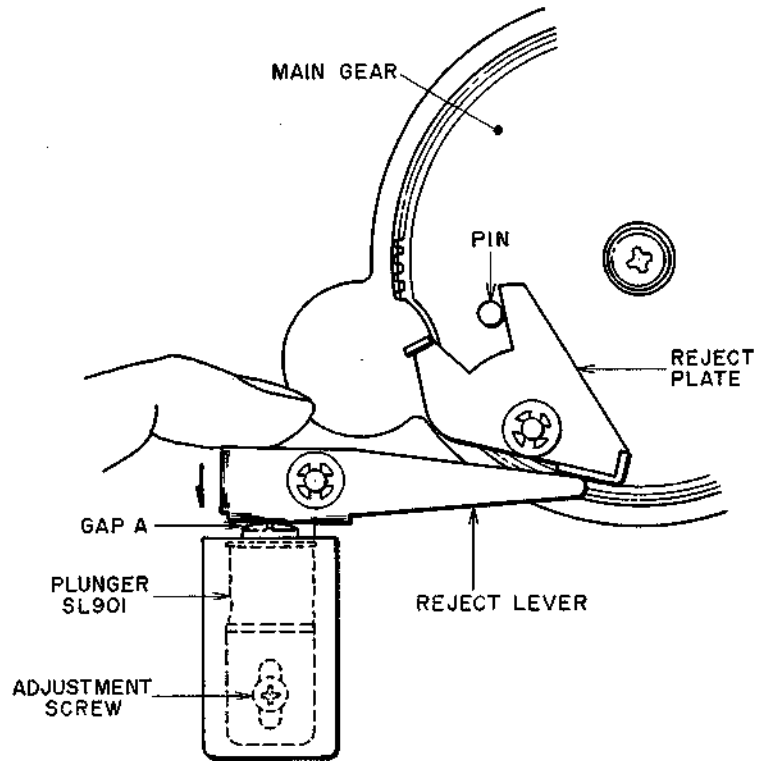

Fig. 19

Remove the motor block. Press the reject lever down with a finger until the reject plate touches the main gear pin. Operate the plunger (SL901) in this position and adjust the installation screw at exactly the point

where the gap A between the reject lever and plunger disappears. (Refer to Fig. 19). After adjustment, confirm that the Auto-Return is operating.

#### 5. LEAD-IN/LEAD-OUT ADJUSTMENT

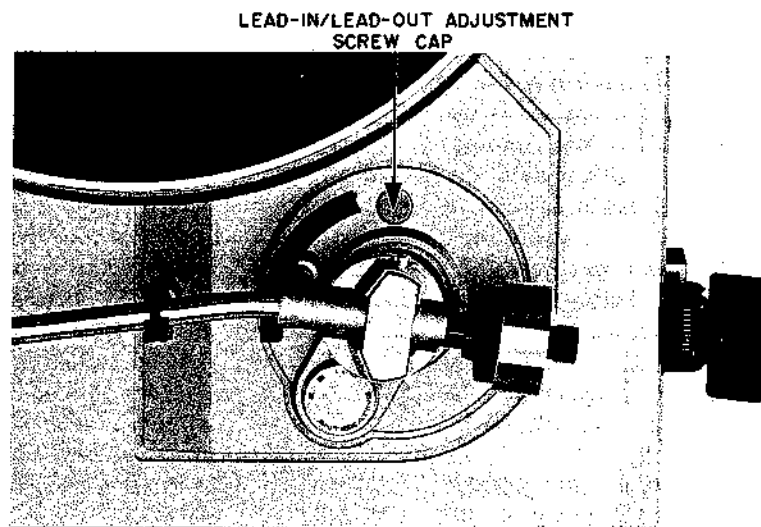

Fig. 20 Lead-in/Lead-out Adjustment

## 1) LEAD-IN ADJUSTMENT

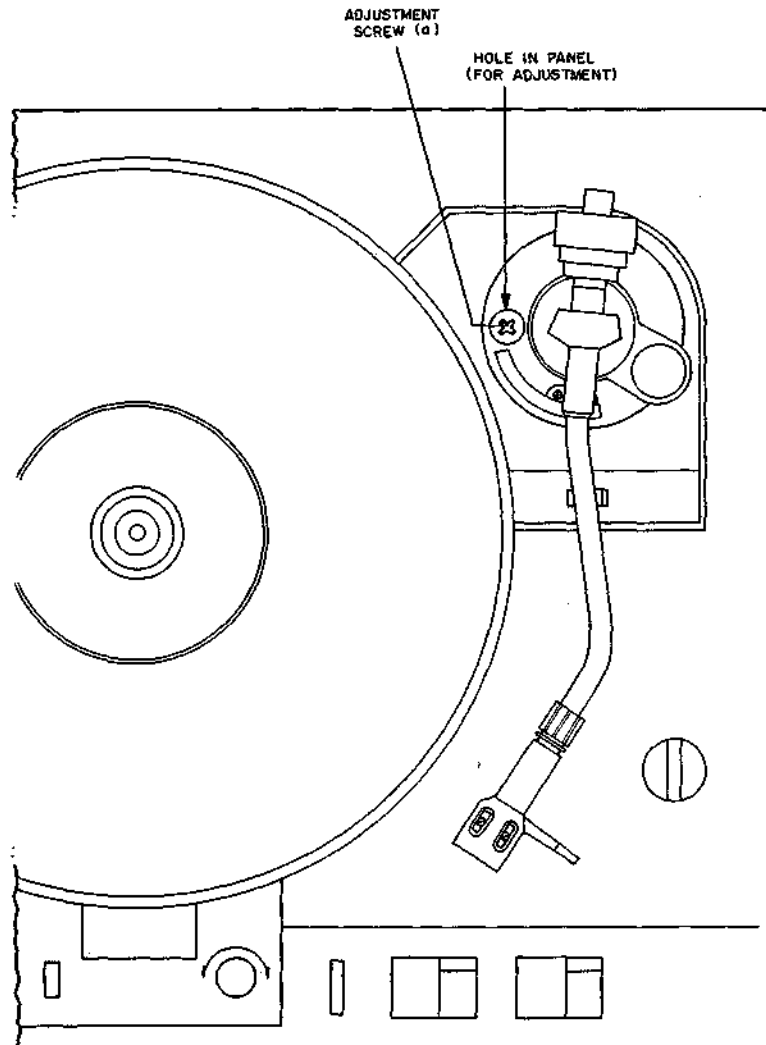

Fig. 21 Lead-in Adjustment

Remove the rubber cap from the tone arm stand. Set the tone arm on the tone arm rest as shown in Fig. 21. The adjustment screw (a) appears in the hole from which the rubber cap has been removed. Turning the adjustment screw (a) clockwise and counterclockwise permits the lead-in position to shift towards the outer rim of the record and towards the center of the record respectively. Therefore, lead-in position adjustment is performed by turning the adjustment screw (a) as follows:

Clockwise	To shift the lead-in position towards the outer rim of the record.
Counterclockwise	To shift the lead-in position towards the center of the record.

- NOTE**
1. The unit is factory adjusted so that, when using the AKAI Model RS-90 cartridge, and 30 cm/25 cm/17 cm JIS records, the stylus descends to the record surface within the range of 293 ~ 298 $\phi$ , 242 ~ 247 $\phi$  or 168 ~ 173 $\phi$  (with the turntable spindle as the diameter center point). Sonosheets or records not in accordance with JIS dimension standards have entirely different lead-in positions. Therefore, when using such records, play then by manual operation instead of adjusting the lead-in position with the adjusting screw.
  2. Be sure to fit the rubber cap after adjustment.

## 2) LEAD-OUT ADJUSTMENT

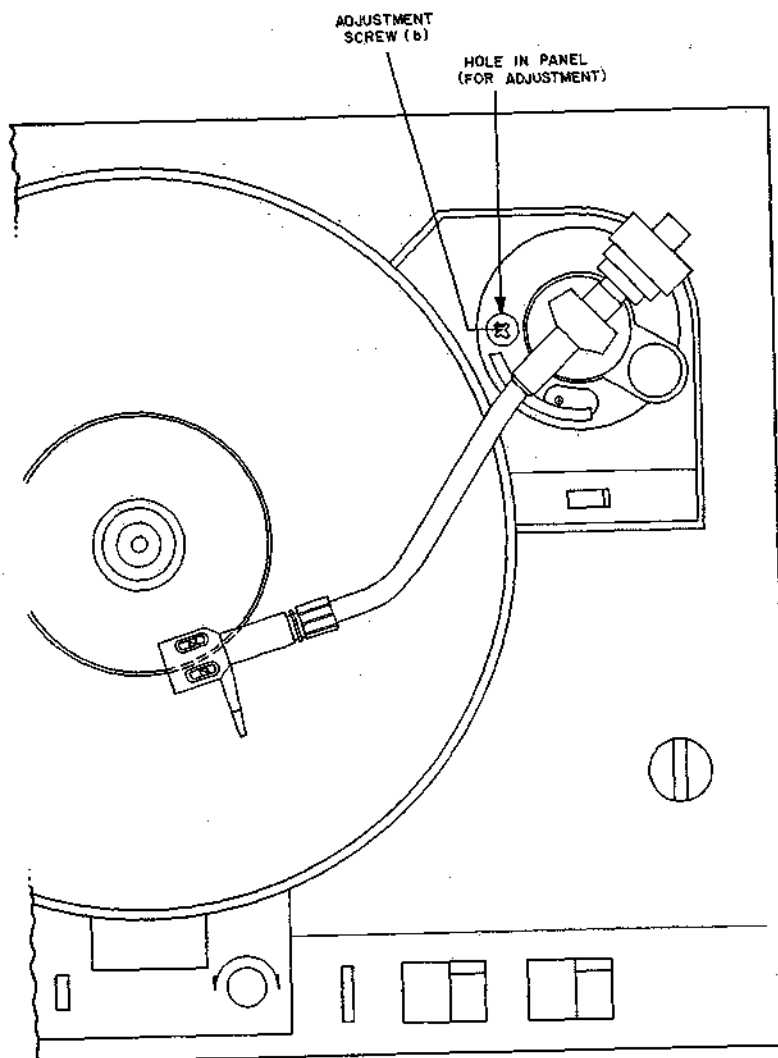

Fig. 22 Lead-out Adjustment

Remove the rubber cap from the tone arm stand. As illustrated in Fig. 22, when the tone arm is shifted from the tone arm rest nearly to the position where the lead-out motion starts, the adjustment screw (b) appears in the hole from which the rubber cap has been removed.

Turning the adjustment screw (b) clockwise and counterclockwise permits the lead-out position to move towards the center of the record and towards the outer rim of the record respectively. Therefore, lead-out position adjustment is performed by turning the adjustment screw (b) as follows:

Clockwise

To move the lead-out position towards the center of the record.

Counterclockwise To move the lead-out position towards the outer rim of the record.

- NOTE**
1. The unit is factory adjusted so that when using the AKAI Model RS-90 cartridge the stylus is led out within the range of  $109 \sim 115\phi$  (with 30 cm/25 cm JIS record) and  $98 \sim 106\phi$  (with 17 cm JIS record) with the turntable spindle as the diameter center point.
  2. Be sure to fit the rubber cap after the adjustment.

# X. ELECTRICAL ADJUSTMENT

## 1. MODEL AP-D40/C

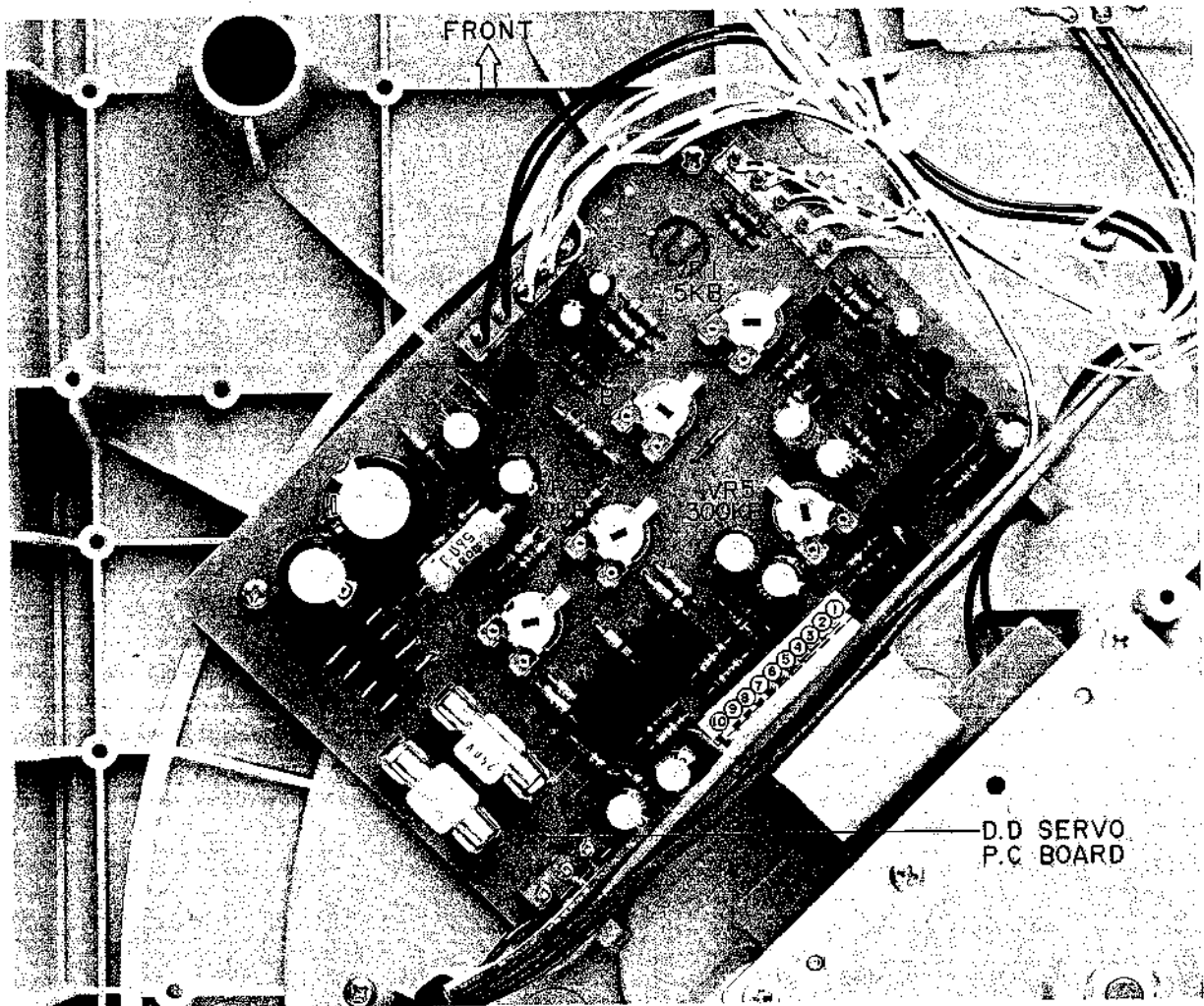

Fig. 23 D.D Servo P.C Board APD-3051

### 1) Off-set Voltage Adjustment (VR3, VR4) and Torque Difference Adjustment (VR5)

- a) Disconnect the motor connection cord.
- b) Short connector (J1) pins ③, ④ and ⑧
- c) Set VR5 (300 kB) to the centre.
- d) Move the Tone Arm and turn on the power.
- e) Connect an oscilloscope to terminal ① of connector J1 and adjust VR3 (20 kB) until it reads -100 mV DC.
- f) Put the Tone Arm on the Arm Rest.
- g) Short connector (J1) pins ⑥, ⑦ and ⑧.
- h) Move the Tone Arm and turn on the power.
- i) Connect an oscilloscope to terminal ② of connector J1 and adjust VR3 (20 kB) until it reads -100 mV DC.
- j) Put the Tone Arm on the Arm Rest and connect the motor connection wire to connector (J1).
- k) Move the Tone Arm and turn on the power.

- l) Connect an oscilloscope to ① and ② of connector (J1).  
Adjust VR5 (300 kB) until the voltage is the same at both ① and ② terminals of connector (J1).

### 2) Speed Adjustment (VR1 and VR2)

- a) Set the Speed Selector to 33-1/3 rpm.
- b) Set the Pitch Control Volume to the centre.
- c) Move the Tone Arm and turn on the power.
- d) Adjust VR2 (5 kB) until the strobe comes to a standstill.
- e) Set the Speed selector to 45 rpm.
- f) Adjust VR1 (5 kB) until the strobe comes to a standstill.

### 3) Wow and Flutter Confirmation

- a) Playback the test record (3,000 Hz).
- b) Confirm that the Wow and Flutter is within 0.035% (JIS).
- c) If not, adjust VR3, VR4 and VR5.



## 2. MODEL AP-Q60/C

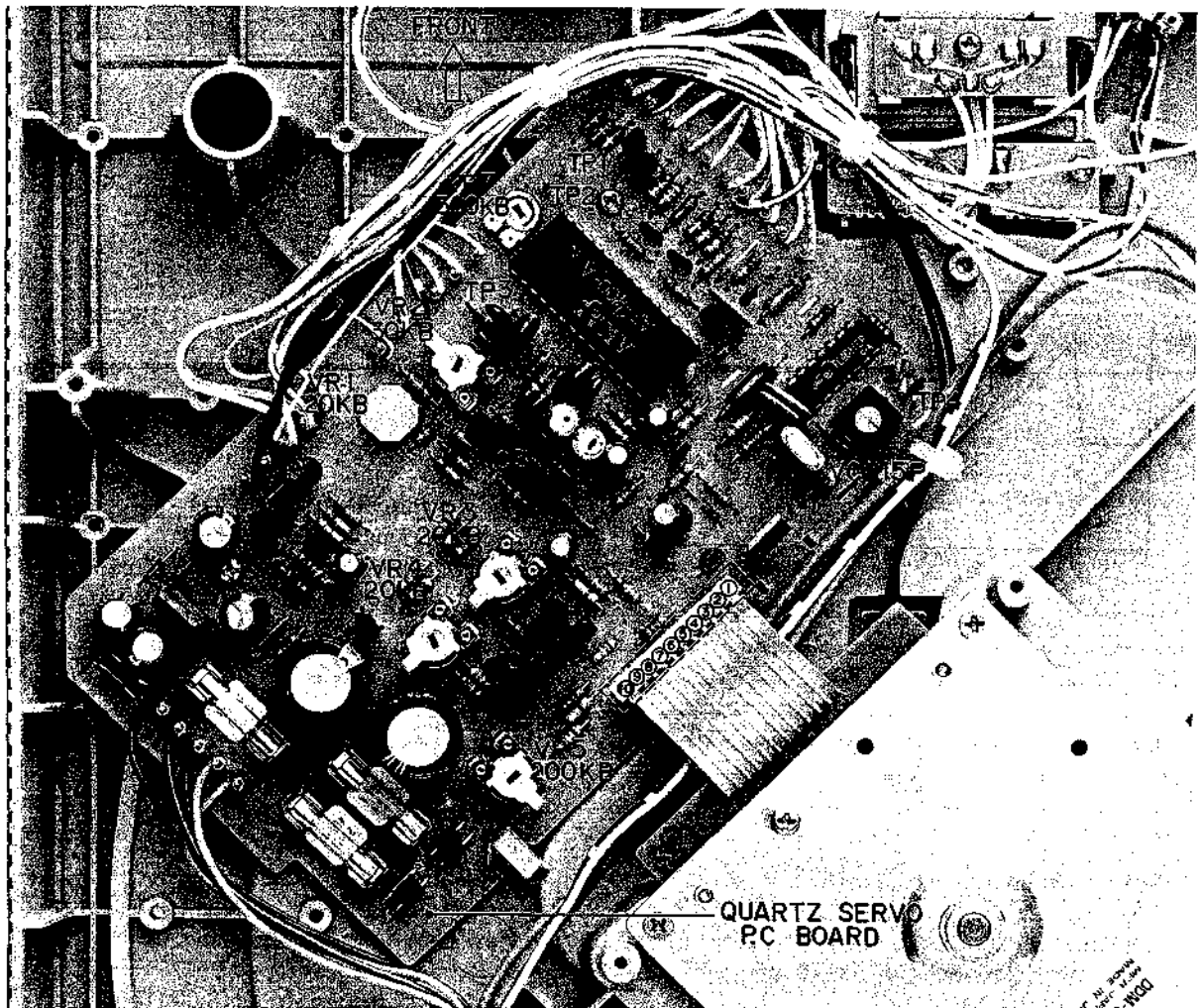

Fig. 24 Quartz Servo P.C Board APQ-5038

- 1) X'tal Oscillation Adjustment (VC1)
  - a) Connect a frequency counter to test point TP4.
  - b) Move the Tone Arm and turn the power on.
  - c) Adjust VC1 (15 P) to give a frequency counter reading of 5.4 MHz.
- 2) Off-set Voltage Adjustment (VR3, VR4) and Torque Difference Adjustment (VR5)
  - a) Disconnect the motor connection wire.
  - b) Short connector (J1) pins ③, ④ and ⑧.
  - c) Move the Tone Arm and turn on the power.
  - d) Connect an oscilloscope to pin ① terminal of connector (J1). Adjust VR3 20 kB until it reads -110 mV DC.
  - e) Put the Tone Arm on the Arm Rest. (Power is OFF).
  - f) Short connector (J1) pins ⑥, ⑦ and ⑧.
  - g) Set VR5 (200 kB) to the centre.
  - h) Move the Tone Arm and turn on the power.
  - i) Connect an oscilloscope to pin ② terminal of connector (J1) and adjust VR4 (20 kB) until it reads -110 mV DC.
  - j) Put the Tone Arm on the Arm Rest and connect the motor connection wire to the connector (J1).
  - k) Move the Tone Arm and turn on the power.
  - l) Connect an oscilloscope to ① and ② of connector (J1).  
Adjust VR5 (200 kB) until the voltage is the same at both ① and ② terminals of connector (J1).

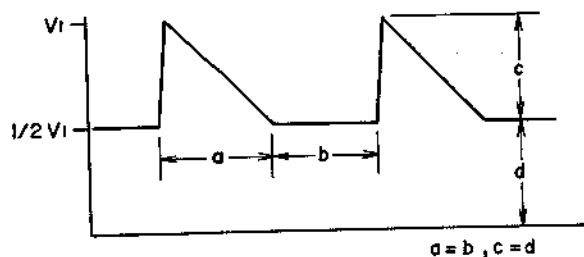
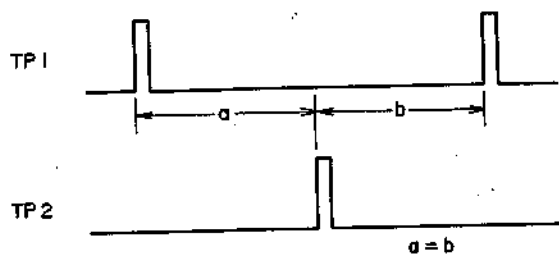

Fig. 25

### 3) Quartz Lock Adjustment

- Set the Size Selector to MANUAL and turn on the power.
- Set the Speed Selector to 45 rpm and the Quartz Switch on.
- Connect an oscilloscope to test point TP3.
- Adjust VR7 (500 kB) to give the waveform in Fig. 25.

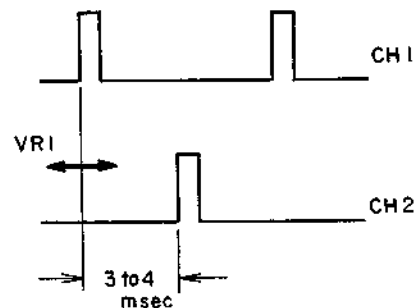

Fig. 26

### 4) Speed Adjustment (VR2)

- Put the Quartz Switch to OFF.
- Set the Speed Selector to 33-1/3 rpm.
- Set the Pitch Control Volume to centre.
- Move the Tone Arm and turn the power on.
- Adjust VR2 (30 kB) until the strobe comes to a standstill.

### 5) Quartz-Locked Phase Angle Adjustment (VR1)

- Put the Quartz Switch to ON.
- Set the Speed Selector to 45 rpm.
- Move the Tone Arm and turn on the power.
- Connect CH-1 of an oscilloscope to TP1 and CH-2 to TP2.
- Adjust VR1 (20 kB) until as in Fig. 26.

### 6) Wow and Flutter Confirmation

- Put the Quartz Switch to OFF.
- Playback the test record (3,000 Hz).
- Check that the Wow and Flutter is to within 0.035% (JIS).
- If not, re-adjust VR3, VR4 and VR5.

## XI. CLASSIFICATION OF VARIOUS P.C BOARDS

### 1. P.C BOARD TITLES AND IDENTIFICATION NUMBER

#### 1) Model AP-D40/C

P.C Board Title	P.C Board Number
D.D Servo P.C Board	APD-3051
Push Switch P.C Board	APD-3053
Intermediate P.C Board	APD-3054
Neon Lamp P.C Board	APD-3056
Reed Switch P.C Board	APD-4056
Fuse P.C Board (A) (U/T)	APD-3052
Fuse P.C Board (B) (CSA, AAL)	APD-3062
Fuse P.C Board (C) (CEE, UK, SAA)	APD-3063

Chart-2

#### 2) Model AP-Q60/C

P.C Board Title	P.C Board Number
Push Switch P.C Board	APD-3053
Intermediate P.C Board	APD-3054
Reed Switch P.C Board	APD-4056
Neon Lamp P.C Board	APQ-5010
LED P.C Board	APQ-5011
FG Sensor P.C Board (B)	APQ-5037
Quartz Servo P.C Board (B)	APQ-5038
Fuse P.C Board (A) (U/T)	APD-3052
Fuse P.C Board (A) (AAL)	APQ-5014
Fuse P.C Board (B) (CSA)	APQ-5016
Fuse P.C Board (C) (CEE, UK, SAA)	APQ-5017

Chart-3

2. MODEL AP-D40/C COMPOSITION OF VARIOUS P.C BOARDS

1) D.D SERVO P.C BOARD APD-3051, PUSH SWITCH P.C BOARD APD-3053 and REED SWITCH P.C BOARD APD-4056 (2ED)

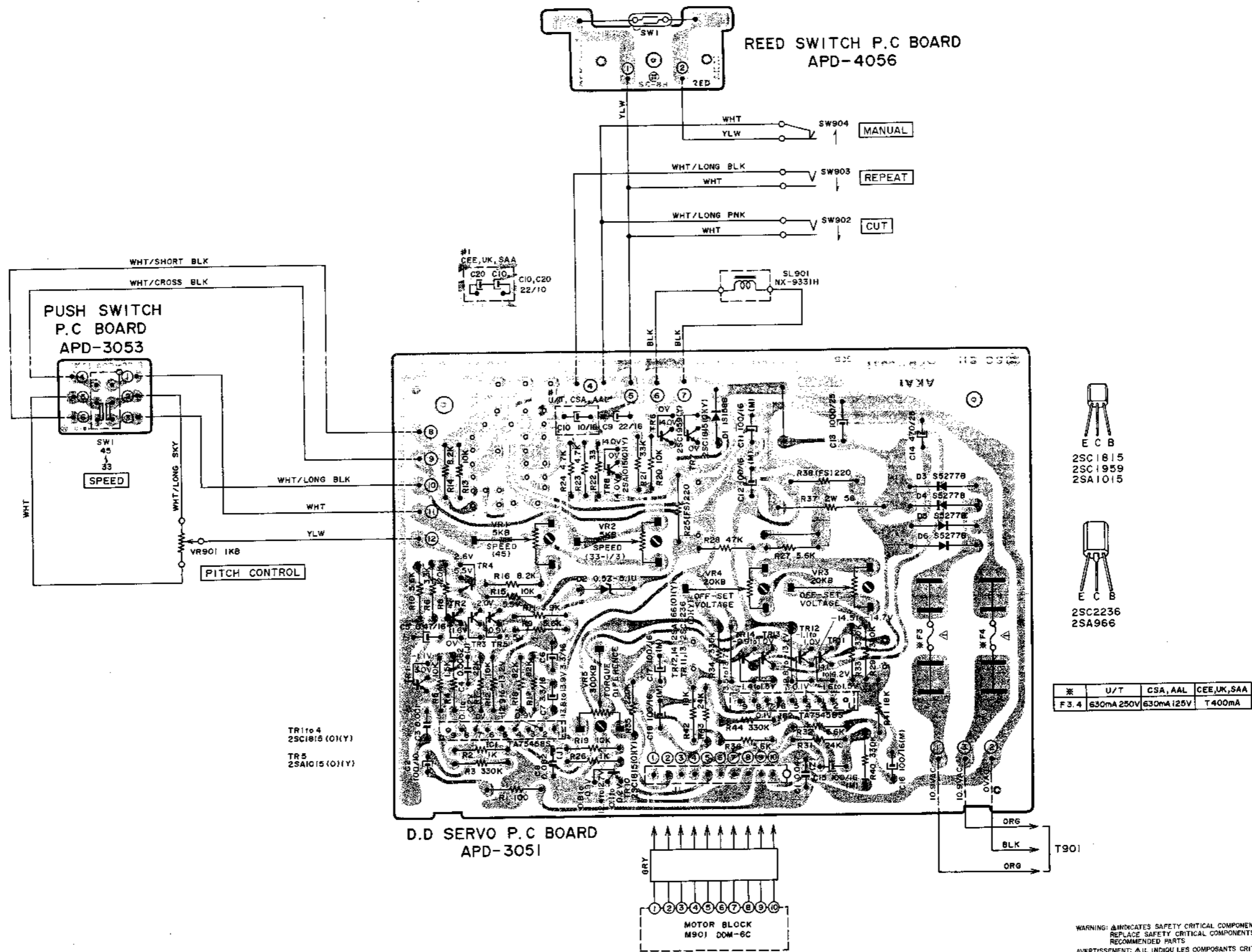

WARNING: Δ INDICATES SAFETY CRITICAL COMPONENTS. FOR CONTINUED SAFETY, REPLACE SAFETY CRITICAL COMPONENTS ONLY WITH MANUFACTURER'S RECOMMENDED PARTS.  
 AVERTISSEMENT: Δ IL INDIQUE LES COMPOSANTS CRITIQUES DE SÛRETÉ. POUR MAINTENIR LE DEGRÉ DE SÛRETÉ DE L'APPAREIL, NE REMPLACER LES COMPOSANTS DONT LE FONCTIONNEMENT EST CRITIQUE POUR LA SÛRETÉ QUE PAR DES PIÈCES RECOMMANDÉES PAR LE FABRICANT.

2) INTERMEDIATE P.C BOARD APD-3054 (2ED)

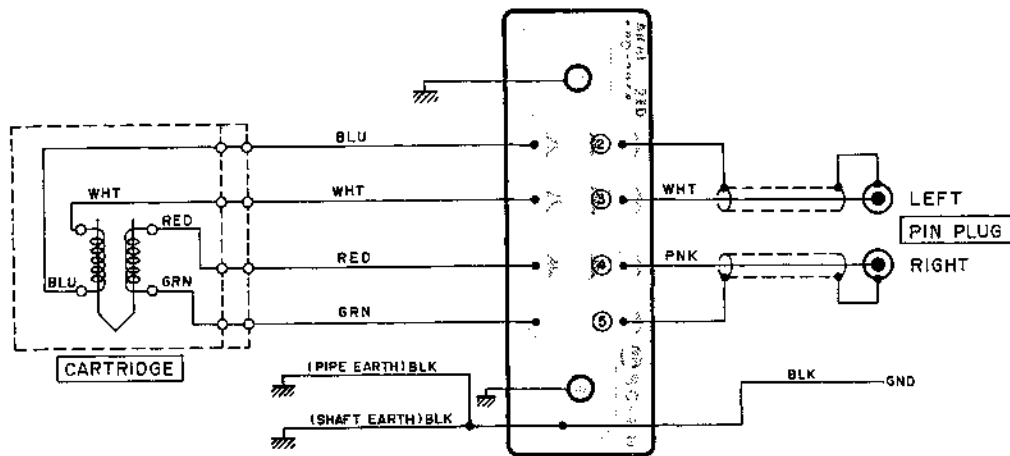

3) FUSE P.C BOARD (A) APD-3052 and NEON LAMP P.C BOARD APD-3056 (U/T)

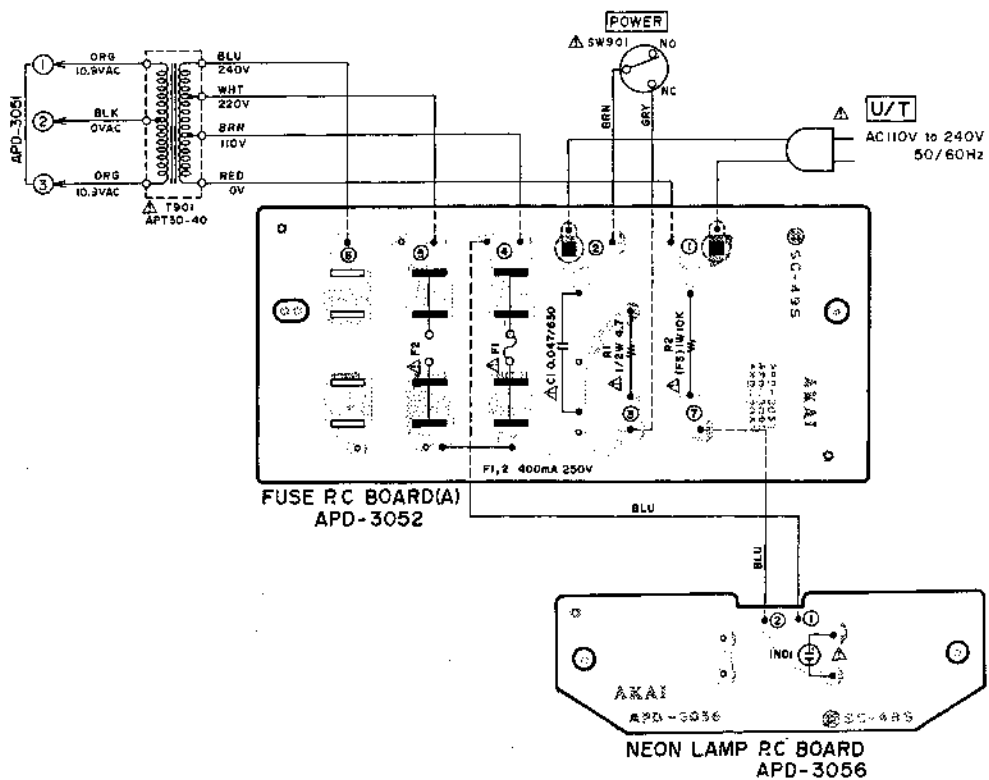

WARNING: Δ INDICATES SAFETY CRITICAL COMPONENTS. FOR CONTINUED SAFETY, REPLACE SAFETY CRITICAL COMPONENTS ONLY WITH MANUFACTURER'S RECOMMENDED PARTS.  
 AVERTISSEMENT: Δ IL INDIQUE LES COMPOSANTS CRITIQUES DE SÛRETÉ. POUR MAINTENIR LE DEGRÉ DE SÛRETÉ DE L'APPAREIL, NE REMPLACER LES COMPOSANTS DONT LE FONCTIONNEMENT EST CRITIQUE POUR LA SÛRETÉ QUE PAR DES PIÈCES RECOMMANDÉES PAR LE FABRICANT.

4) FUSE P.C BOARD (B) APD-3062 and NEON LAMP P.C BOARD APD-3056 (CSA, AAL)

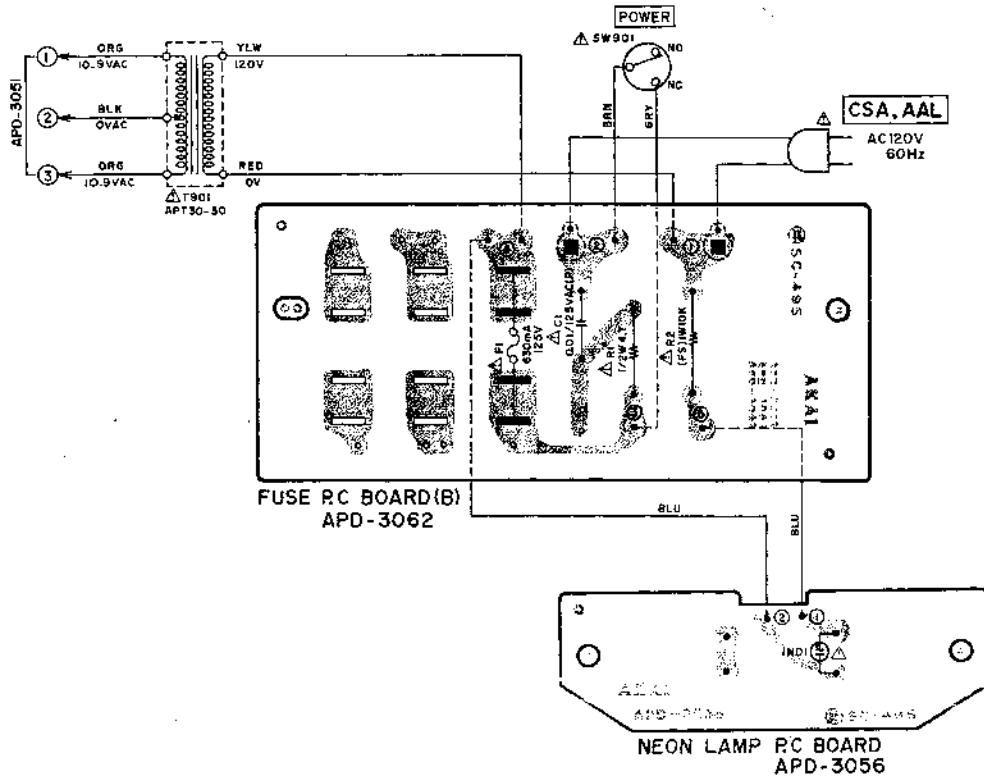

5) FUSE P.C BOARD (C) APD-3063 and NEON LAMP P.C BOARD APD-3056 (CEE, UK, SAA)

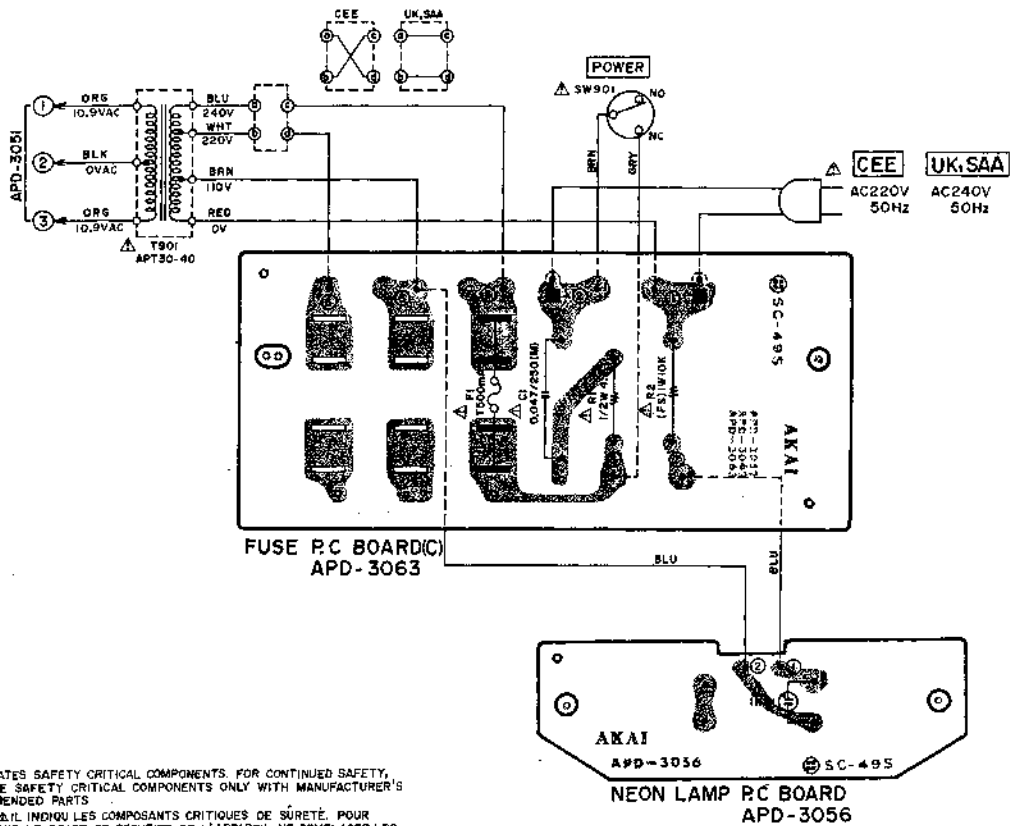

WARNING: Δ INDICATES SAFETY CRITICAL COMPONENTS. FOR CONTINUED SAFETY, REPLACE SAFETY CRITICAL COMPONENTS ONLY WITH MANUFACTURER'S RECOMMENDED PARTS.  
 AVERTISSEMENT: Δ IL INDIQUE LES COMPOSANTS CRITIQUES DE SÛRETÉ. POUR MAINTENIR LE DEGRÉ DE SÛRETÉ DE L'APPAREIL, NE REMPLACER LES COMPOSANTS DONT LE FONCTIONNEMENT EST CRITIQUE POUR LA SÛRETÉ QUE PAR DES PIÈCES RECOMMANDÉES PAR LE FABRICANT.

3. MODEL A P-Q60/C COMPOSITION OF VARIOUS P.C BOARDS

1) QUARTZ SERVO P.C BOARD (B) APQ-5038 (2ED), PUSH SWITCH P.C BOARD APD-3053, REED SWITCH P.C BOARD APD-4056 (2ED), NEON LAMP P.C BOARD APQ-5010, LED P.C BOARD APQ-5011 and FG SENSOR P.C BOARD (B) APQ-5037

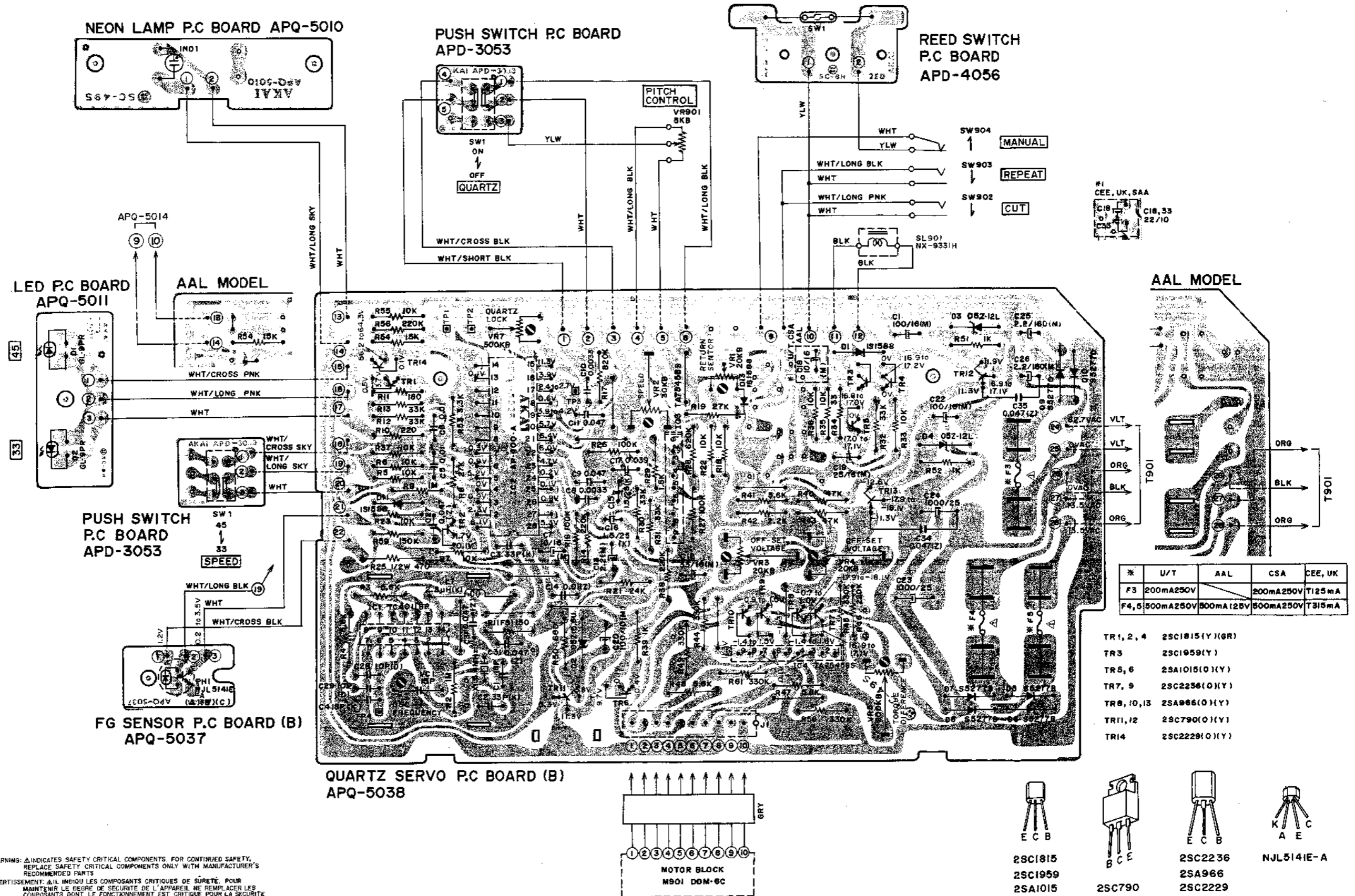

2) INTERMEDIATE P.C BOARD APD-3054 (2ED)

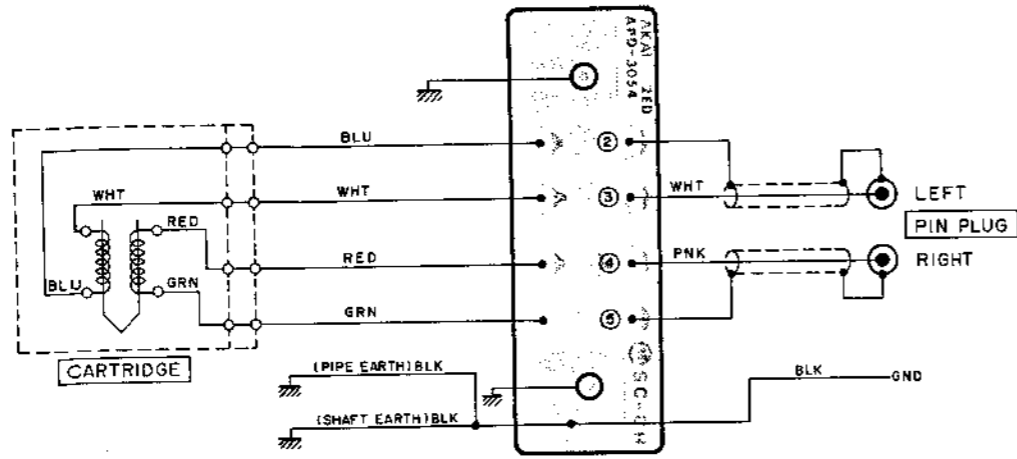

4) FUSE P.C BOARD (B) APQ-5016 (2ED) (CSA)

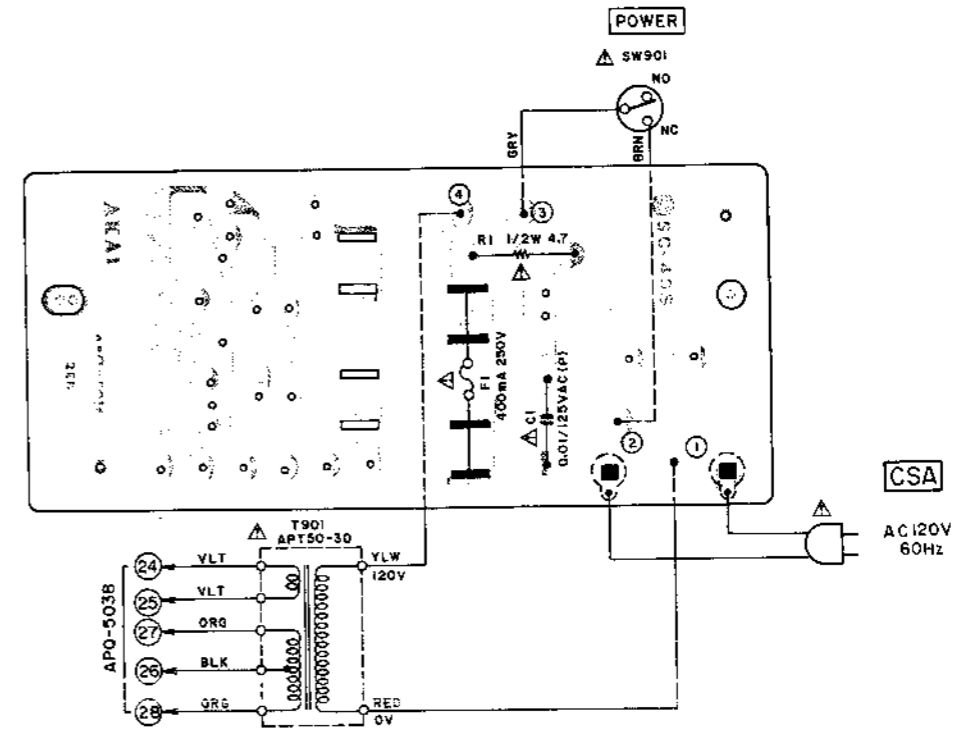

3) FUSE P.C BOARD (A) APD-3052 (U/T)

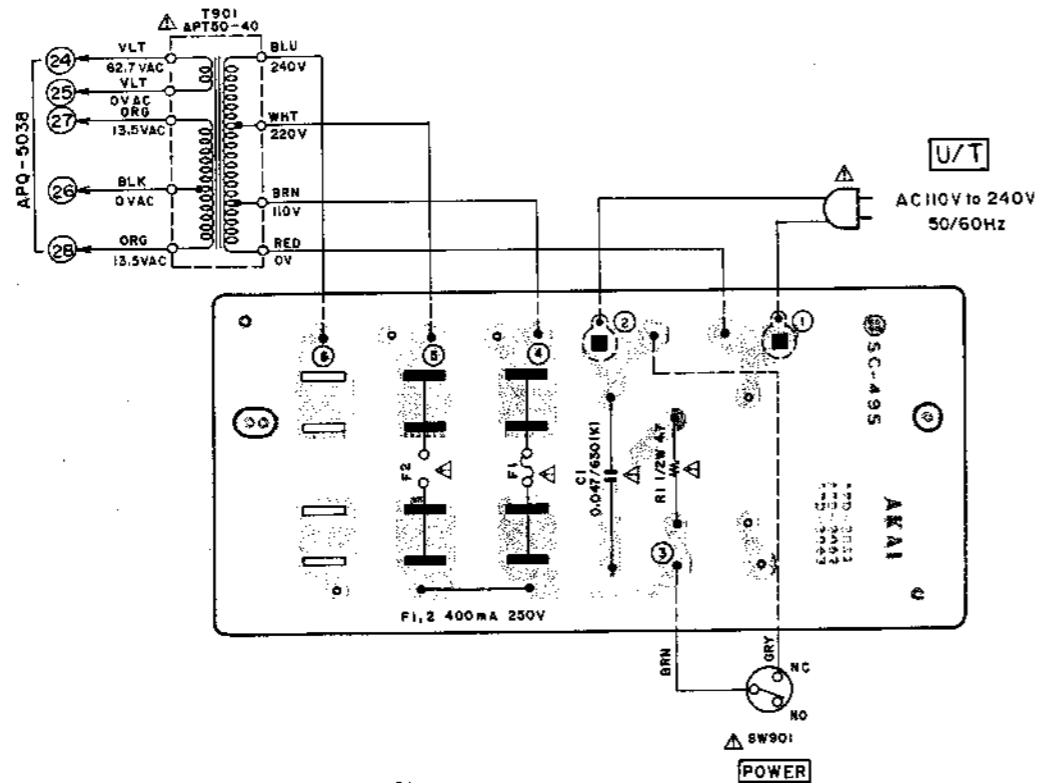

5) FUSE P.C BOARD (C) APQ-5017 (2ED) (CEE, UK, SAA)

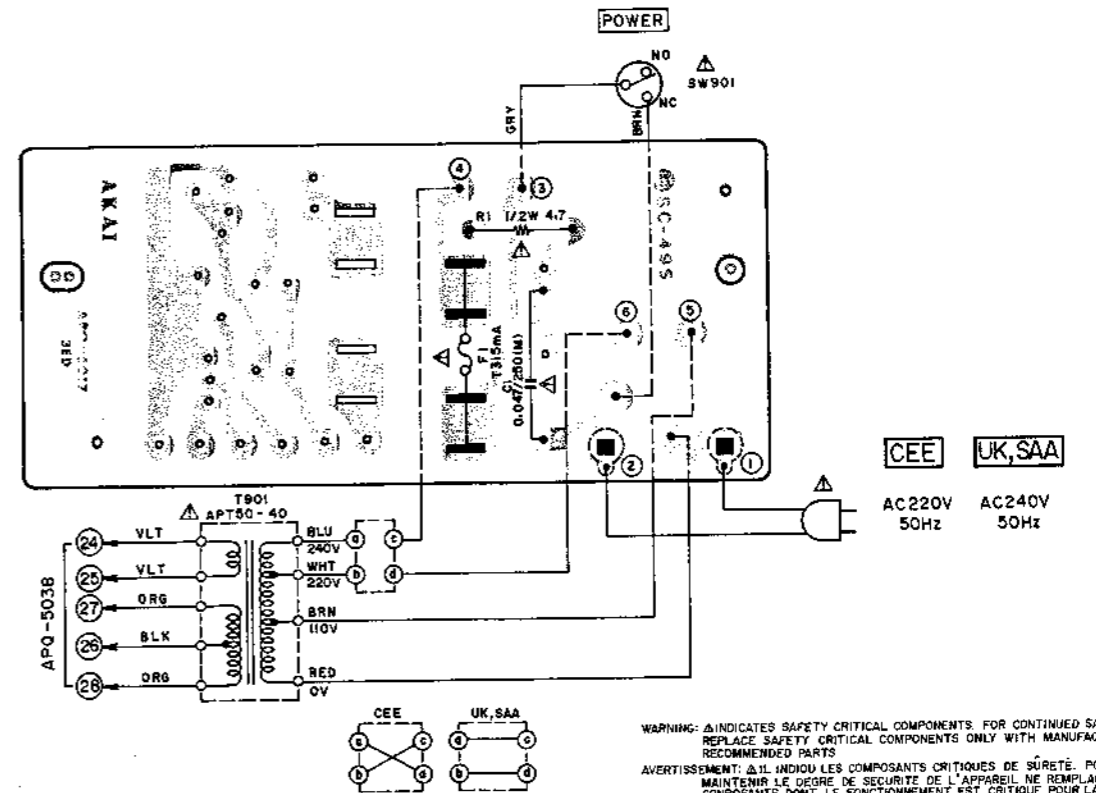

WARNING: Δ INDICATES SAFETY CRITICAL COMPONENTS. FOR CONTINUED SAFETY, REPLACE SAFETY CRITICAL COMPONENTS ONLY WITH MANUFACTURER'S RECOMMENDED PARTS.  
 AVERTISSEMENT: Δ IL INDIQUE LES COMPOSANTS CRITIQUES DE SÛRETÉ. POUR MAINTENIR LE DEGRÉ DE SÛRETÉ DE L'APPAREIL, NE REMPLACER LES COMPOSANTS DONT LE FONCTIONNEMENT EST CRITIQUE POUR LA SÛRETÉ QUE PAR DES PIÈCES RECOMMANDÉES PAR LE FABRICANT.

WARNING: Δ INDICATES SAFETY CRITICAL COMPONENTS. FOR CONTINUED SAFETY, REPLACE SAFETY CRITICAL COMPONENTS ONLY WITH MANUFACTURER'S RECOMMENDED PARTS.  
 AVERTISSEMENT: Δ IL INDIQUE LES COMPOSANTS CRITIQUES DE SÛRETÉ. POUR MAINTENIR LE DEGRÉ DE SÛRETÉ DE L'APPAREIL, NE REMPLACER LES COMPOSANTS DONT LE FONCTIONNEMENT EST CRITIQUE POUR LA SÛRETÉ QUE PAR DES PIÈCES RECOMMANDÉES PAR LE FABRICANT.



6) FUSE P.C BOARD (A) APQ-5014 (2ED) (AAL)

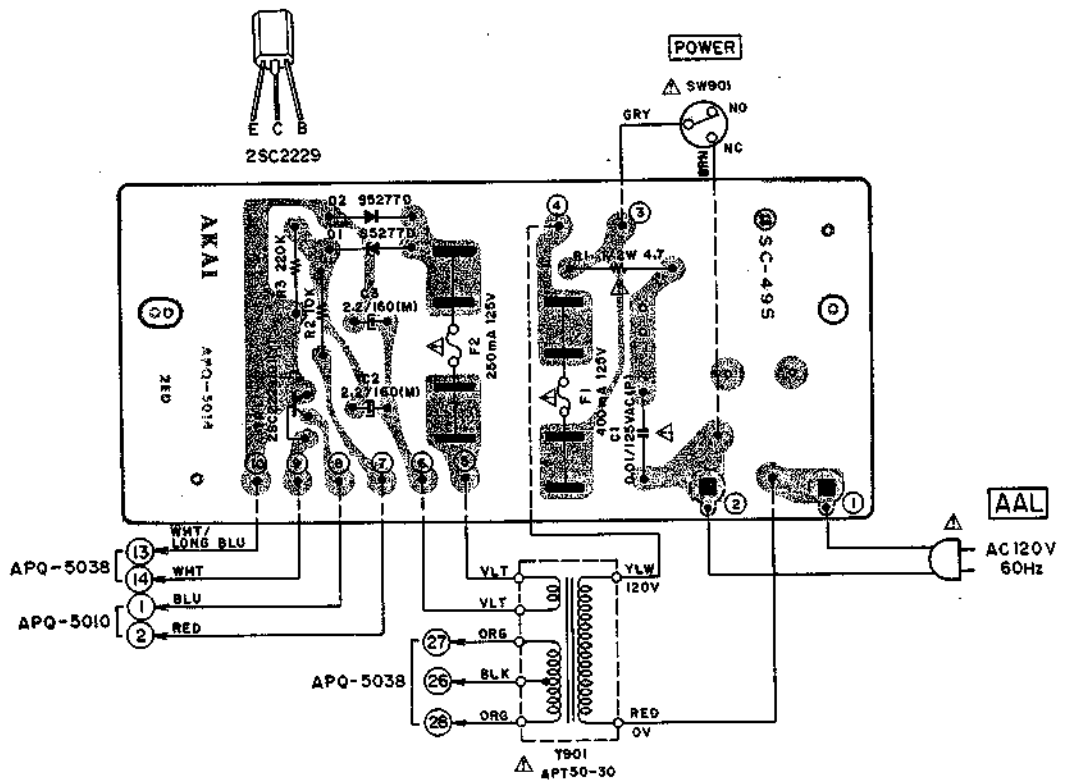

WARNING: ⚠ INDICATES SAFETY CRITICAL COMPONENTS. FOR CONTINUED SAFETY, REPLACE SAFETY CRITICAL COMPONENTS ONLY WITH MANUFACTURER'S RECOMMENDED PARTS.

AVERTISSEMENT: ⚠ IL INDIQUE LES COMPOSANTS CRITIQUES DE SÛRETÉ. POUR MAINTENIR LE DEGRÉ DE SÛRETÉ DE L'APPAREIL, NE REMPLACER LES COMPOSANTS DONT LE FONCTIONNEMENT EST CRITIQUE POUR LA SÛRETÉ QUE PAR DES PIÈCES RECOMMANDÉES PAR LE FABRICANT.

---

SECTION 3

**PARTS LIST**

TABLE OF CONTENTS

I. MODEL AP-D40/C

- 1. RECOMMENDED SPARE PARTS LIST ..... 42
- 2. DD SERVO P.C BOARD (APD-3051) COMP. .... 43
- 3. FUSE P.C BOARD (APD-3052/3062/3063) COMP. .... 43
- 4. ASSEMBLY BLOCK (1) ..... 44
- 5. ASSEMBLY BLOCK (2) ..... 46
- 6. FINAL ASSEMBLY BLOCK ..... 48

II. MODEL AP-Q60/C

- 1. RECOMMENDED SPARE PARTS LIST ..... 49
- 2. QUARTZ SERVO P.C BOARD (APQ-5038) COMP. .... 51
- 3. FUSE P.C BOARD (APD-3052/APQ-5014/5016/5017)  
COMP. .... 51
- 4. ASSEMBLY BLOCK (1) ..... 52
- 5. ASSEMBLY BLOCK (2) ..... 54
- 6. FINAL ASSEMBLY BLOCK ..... 56

INDEX

- 1. MODEL AP-D40/C ..... 57
- 2. MODEL AP-Q60/C ..... 58

Resistor and Capacitor which is not listed in this parts list, please refer to COMMON LIST FOR SERVICE PARTS.

## HOW TO USE THIS PARTS LIST

1. This parts list is compiled by various individual blocks based on assembly process.
2. When ordering parts, please describe parts number, serial number, and model number in detail.
3. How to read List

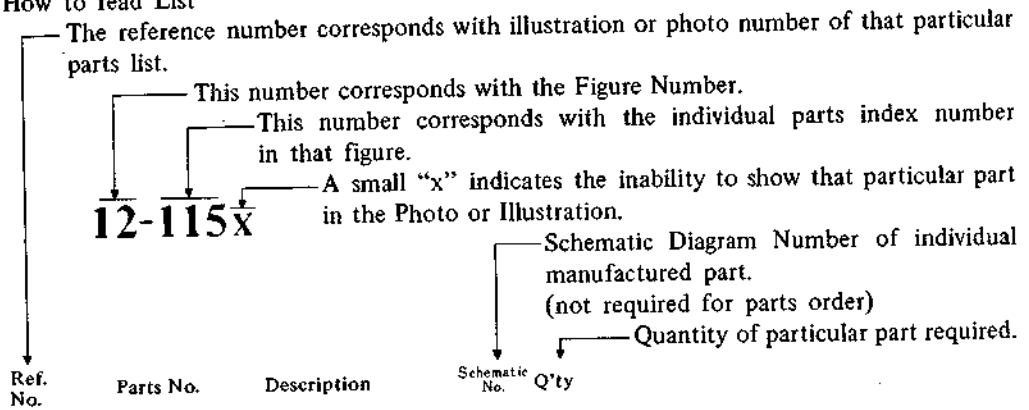

Ref. No.	Parts No.	Description	Schematic No.	Q'ty
<b>FLYWHEEL BLOCK #13</b>				
12-115x	800425	Flywheel Block Assy. Comp.	RDG #13	1
12-116	244506	Flywheel Only	RD-233	1
12-117x	244754	Felt, Flywheel	RD-275	1
12-118	251324	Main Metal Case	RD-236	1
12-119	253080	Main Metal	RD-237	1

4. The symbol numbers shown on the P.C. Board list can be matched with the Composite Views of Components of the Schematic Diagram or Service Manual.
5. Please utilize separate "Common List for Service Parts" for Resistor Parts orders.
6. The shape of the parts and parts name, etc. can be confirmed by comparing them with the parts shown on the Electrical Parts Table of P.C. Board.
7. Both the kind of part and installation position can be determined by the Parts Number. To determine where a parts number is listed, utilize Parts Index at end of Parts List.  
It is necessary first of all to find the Parts Number. This can be accomplished by using the Reference Number listed at right of parts number in the Parts Index. (meaning of ref. no. outlined in Item 3 above).
8. Utilize separate "Price List for Parts" to determine unit price. The most simple method of finding parts Price is to utilize the reference number.

- CAUTION:**
1. When placing an order for parts, be sure to list the parts no., model no., and description. There are instances in which if any of this information is omitted, parts cannot be shipped or the wrong parts will be delivered.
  2. Please be careful not to make a mistake in the parts no. If the parts no. is in error, a part different from the one ordered may be delivered.
  3. Because parts number and parts unit supply in the Preliminary Service Manual (Basic Parts List) may be partially changed, please use this parts list for all future reference.

**WARNING:** **⚠** INDICATES SAFETY CRITICAL COMPONENTS. FOR CONTINUED SAFETY, REPLACE SAFETY CRITICAL COMPONENTS ONLY WITH MANUFACTURER'S RECOMMENDED PARTS.

**AVERTISSEMENT:** **⚠** IL INDIQU LES COMPOSANTS CRITIQUES DE SURETE. POUR MAINTENIR LE DEGRE DE SECURITE DE L'APPAREIL NE REMPLACER LES COMPOSANTS DONT LE FONCTIONNEMENT EST CRITIQUE POUR LA SECURITE QUE PAR DES PIECES RECOMMANDEES PAR LE FABRICANT.

## AC INLET SYSTEM

This model is equipped with an AC INLET SYSTEM. Please refer to the AC INLET SYSTEM CHART below for the specific type. By the AC INLET SYSTEM, AC (mains) cord can be connected to and disconnected from the model because the model is provided with socket exclusively for AC (mains) cord on its main body. Please note, however, that certain models are not equipped with this system and has a built-in AC (mains) cord as before.

### AC INLET SYSTEM CHART

#### CLASS I

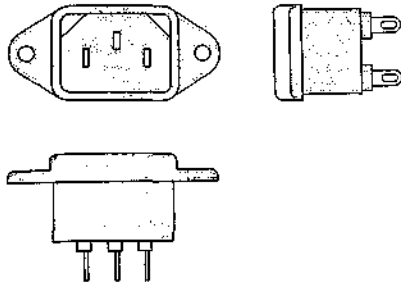

Picture 1  
AC INLET  
to be  
installed  
on machines

#### CLASS II

☐ This mark indicating double insulation will be attached to machine's rear panel

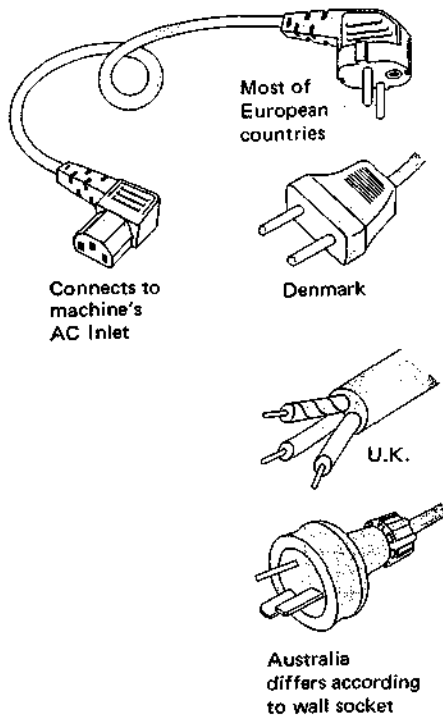
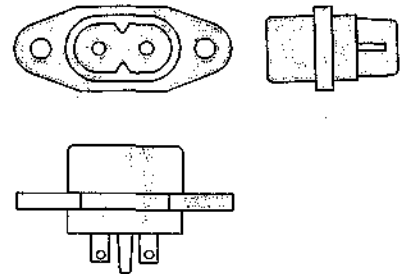

Picture 2  
AC (mains)  
cord

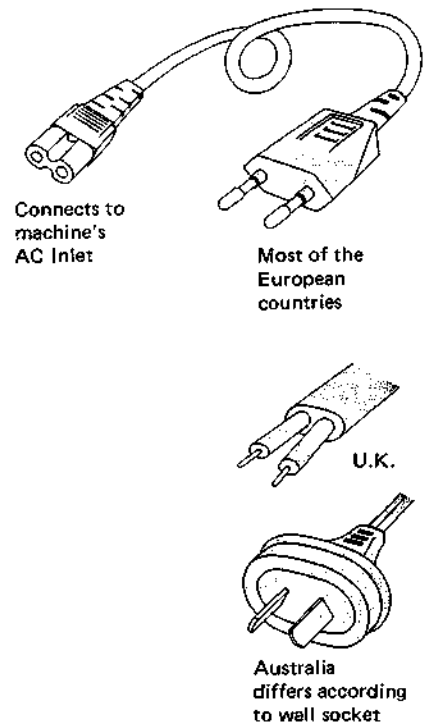

#### Parts List for AC (mains) Cord Set

	Standard	Description	Type of AC Inlet	Parts No.
Class I	CEE	Cord Set CEE (3 cores)	3P	EW302993
	BEAB	Cord Set BEAB (3 cores)	3P	EW302994
	SAA	Cord Set SAA (3 cores)	3P	EW302996
	U/T	Cord Set U/T (3 cores)	3P	EW302646
Class II	CEE	Cord Set CEE (2 cores)	2P	EW638144
	BEAB	Cord Set BEAB (2 cores)	2P	EW302995
	SAA	Cord Set SAA (2 cores)	2P	EW302991
	U/T	Cord Set U/T (2 cores)	2P	EW302899

# I. MODEL AP-D40/C

## 1. RECOMMENDED SPARE PARTS LIST

Because, if the parts listed below are on hand, almost any repair can be accomplished, we suggest that you stock these Recommended Spare Parts Items.

Parts No.	Description	Notes
BA327660	DD Servo P.C Board Comp. AP-D40 (C)	JPN, CSA, AAL
BA327661	DD Servo P.C Board Comp. AP-D40 (E)	CEE, UK, SAA
BA327659	DD Servo P.C Board Comp. AP-D40 (U)	U/T
BM320724	Motor BLK DDM-6C	
BT328576	△ Trans Power APT30-10	JPN
BT325487	△ Trans Power APT30-30	CSA, AAL
BT325486	△ Trans Power APT30-40	U/T, CEE, UK, SAA
ED321115	D Silicon H LB-5 F10	
ED306724	D Silicon S5277B 100/1.0A	
ED322774	D Zener H 05Z5.1 U	
EF668474	△ Fuse Semko T 250V 0.40A	CEE, SAA, UK
EF593706	△ Fuse Semko T 250V 0.50A	CEE, UK, SAA
EF309389	△ Fuse TSC A 250V 0.40A	U/T
EF306124	△ Fuse TSC A 250V 0.63A	U/T
EF305703	△ Fuse TSC 125V 0.63A	CSA, AAL, JPN
EI322599	IC TA75458S	
EL306690	△ NL Lead NE-2HH 822/100AC	
EP320723	Plunger Assy NX-9331H	
ES326961	SW Leaf MSW-0026TU 01-1 NO	
ES325483	SW Leaf MSW-0061BU 01-1 NO	
ES325488	△ SW Micro K1 UCE	
ES325493	SW Push SPJ222L 2-02-02S	
ES651745	SW Reed HR-10L	
ET325501	TR 2SA1015 (O) (Y)	
ET306720	TR 2SA966 (O) (Y)	
ET306705	TR 2SC1815 (O) (Y)	
ET325482	TR 2SC1959 (Y)	
ET306719	TR 2SC2236 (O) (Y)	
EV560136	R S-Fix H V10K8-4-2 3P 203	
EV499882	R S-Fix H V10K8-4-2 3P 304	
EV499364	R S-Fix H V10K8-4-2 3P 502	
EV325494	VR Rotary 16S10x0B B102	
EW313884	△ AC Cord 2 Cores GTBS-2F B	SAA
EW306427	△ AC Cord 2 Cores KP-211, VFF J	JPN
EW313882	△ AC Cord 2 Cores KP-419C, LTCE-2F E	CEE
EW374894	△ AC Cord 2 Cores VM-0129A J	U/T
EW207742	△ AC Cord 2 Cores VM-0238 UC	CSA, AAL

## 2. DD SERVO P.C BOARD (APD-3051) COMP.

Symbol No.	Parts No.	Description	Schematic No.
2-1	BA327659	DD Servo P.C Board Comp. AP-D40 (U) (U/T)	
2-2	BA327660	DD Servo P.C Board Comp. AP-D40 (C) (JPN, CSA, AAL)	
2-3	BA327661	DD Servo P.C Board Comp. AP-D40 (E) (CEE, UK, SAA)	
2-IC1,2	EI322599	IC TA75458S	45-8-415
2-TR1to4	ET306705	TR 2SC1815(O)(Y)	45-1-299
2-TR5	ET325501	TR 2SA1015(O)(Y)	45-1-328
2-TR6	ET325482	TR 2SC1959(Y)	45-1-385
2-TR7	ET306705	TR 2SC1815(O)(Y)	45-1-299
2-TR8	ET325501	TR 2SA1015(O)(Y)	45-1-328
2-TR10	ET306705	TR 2SC1815(O)(Y)	45-1-299
2-TR11	ET306719	TR 2SC2236(O)(Y)	45-1-307
2-TR12	ET306720	TR 2SA966(O)(Y)	45-1-306
2-TR13	ET306719	TR 2SC2236(O)(Y)	45-1-307
2-TR14	ET306720	TR 2SA966(O)(Y)	45-1-306
2-D1	ED321115	D Silicon H LB-5 F10	45-3-62
2-D2	ED322774	D Zener H 05Z5.1 U	45-6-76
2-D3to6	ED306724	D Silicon S5277B 100/1.0A	45-2-79
2-VR1,2	EV499364	R S-Fix H V10K8-4-2 3P 502	36-10-250
2-VR3,4	EV560136	R S-Fix H V 10K8-4-2 3P 203	36-10-250
2-VR5	EV499882	R S-Fix H V10K8-4-2 3P 304	36-10-250
2-R25	ER308849	R CB H SNP FS RD 1/4W 221J	35-11-25
2-R37	ER304256	R OMF H 2W 560J	35-15-8
3-R38	ER308849	R CB H SNP FS RD 1/4W 221J	35-11-25
2-C5	EC317650	C SA V F05 R47K 16.0DC	24-19-3
2-C6,7	EC325497	C SA V F05 3R 3K 16.0DC	24-19-3
2-C13	EC316188	C EC V CUT SM 102 25.0DC	24-12-49
2-F3,4	EF306124	Δ Fuse TSC A 250V 0.63A (U/T)	39-1-64
2-F3,4	EF305703	Δ Fuse TSC 125V 0.63A (JPN, CSA, AAL)	39-1-65
2-F3,4	EF668474	Δ Fuse Semko T 250V 0.40A (CEE, SAA, UK)	39-1-53

## 3. FUSE P.C BOARD (APD-3052/3062/3063) COMP.

Symbol No.	Parts No.	Description	Schematic No.
3-R2	ER314983	R OMF H SNP FS 1W 103J	35-11-21
3-C1	EC302898	Δ C MMY V MDD 473K 630DC (U/T)	24-9-120
3-C1	EC314688	Δ C CE V FZ 103P 125AC (CSA, AAL)	24-5-87
3-C1	EC325485	Δ C MP V 473M 250AC (CEE, UK, SAA)	24-9-134
3-C1	EC321302	Δ C CE V E 103Z 250DC (JPN)	24-5-90
3-F1,2	EF309389	Δ Fuse TSC A 250V 0.40A (U/T)	39-1-64
3-F1	EF305703	Δ Fuse TSC 125V 0.63A (CSA, AAL, JPN)	39-1-65
3-F1	EF593706	Δ Fuse Semko T 250V 0.50A (CEE, UK, SAA)	39-1-53

#### 4. ASSEMBLY BLOCK (1)

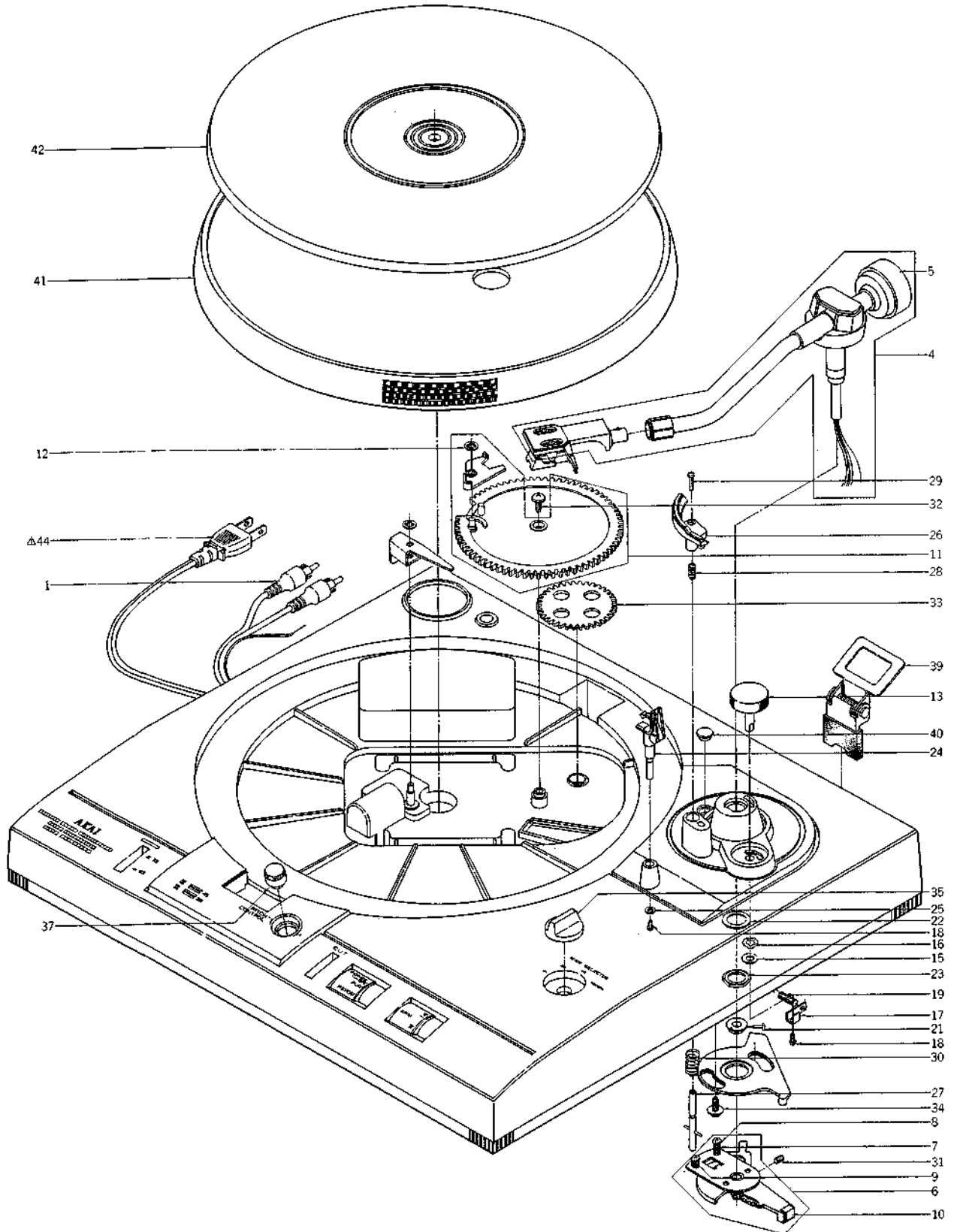

## ASSEMBLY BLOCK (1)

Ref. No.	Parts No.	Description	Schematic No.
4-1	EW325490	Cord P-54-027 2P Audio (Ext. JPN, AAL)	26-10-20
4-2x	EW325489	Cord P-54-075 2P Audio (AAL)	26-10-19
4-3x	EW302795	Cord P52-030-3 2P Audio (JPN)	26-8-12
4-4	TP320747	Tone Arm Part ARM-30	53-1-185
4-5	TP325499	Main Weight	53-1-185
4-6	TP327663	PU Plate Assy AP-D40	
4-7	ZG312997	SP T1-4.0/0.4-16.0	
4-8	ZS305246	Adjust Screw (B)	AP-00117
4-9	ZG313183	SP C-4.5/0.4-8.0	
4-10	TP302925	Ferrite Magnet	5-1-19
4-11	TP327665	Main Gear Assy AP-D40	
4-12	ZW653163	Ring CS280STL PKR	6-1-14
4-13	SK320740	Canceller Knob Par AP-D30	APD-3050
4-14x	SK320741	Canceller Knob Part AP-D30-BL	APD-3050
4-15	ZW313593	PW51×103×050P BR	
4-16	ZW315478	Wave Washer D5 SUS	
4-17	ML302852	Lever	AP-0020
4-18	ZS669104	T2PAN23×06STL CMT	
4-19	ZG302825	Coil Spring (4)	AP-0021
4-20x	ZG321734	Canceller Spring	AP-9047
4-21	ZS590804	PAN23×06STL CMT	
4-22	ZW325517	PW13×200×050STL CMT	
4-23	ZW327271	Arm Fixation Nut	APD-4015
4-24	TP320742	Arm Rest Part AP-D30	APD-3006
4-25	ZW300888	PW23×060×040BRS NI3	
4-26	TP320743	Elevation Arm Part AP-D30	APD-3008
4-27	TP327270	Elevation Shaft Part	APD-4014
4-28	ZG325470	Elevation Hight Adjust Spring	APD-3064
4-29	ZS325520	PAN26×12STL BNI	
4-30	ZG325402	Elevation Spring	APD-3010
4-31	ZS356804	6SET30×040SCM PKR HP	
4-32	ZS327438	PT BR30×10STL CMT C	7-1-78
4-33	TP327275	Sub Gear	APD-4018
4-34	ZS297641	T2BID30×08STL CMT PW100	
4-35	SK327287	Knob	APD-4028
4-36x	SK327288	Knob (BL)	APD-4028
4-37	SK325414	Control Knob	APD-3020
4-38x	SK325415	Control Knob (BL)	APD-3020
4-39	TP320745	Hinge (D) Part AP-D30	9-4-9
4-40	TP302504	Rubber Bush	AP-0043
4-41	TP325522	Platter	1-34-5
4-42	TP325443	Table Sheet (Ext. AAL)	APD-3046
4-43x	TP323593	Table Sheet (B) (AAL)	APD-3046
4-44	EW374894	△ AC Cord 2 Cores VM-0129A J (U/T)	26-3-19
4-45x	EW306427	△ AC Cord 2 Cores KP-211, VFF J (JPN)	26-3-63
4-46x	EW207742	△ AC Cord 2 Cores VM-0238 UC (CSA, AAL)	26-3-45
4-47x	EW313882	△ AC Cord 2 Cores KP-419C, LTCE-2F E (CEE)	26-3-66
4-48x	EW313884	△ AC Cord 2 Cores GTBS-2F B (UK)	26-3-67
4-49x	EW313883	△ AC Cord 2 Cores KP-560, VFSA-2-S (SAA)	26-3-69
4-50x	ZS421740	PAN30×08STL BNI (AAL)	
4-51x	ZW273835	N30BRS NI3 1 (AAL)	



# 5. ASSEMBLY BLOCK (2)

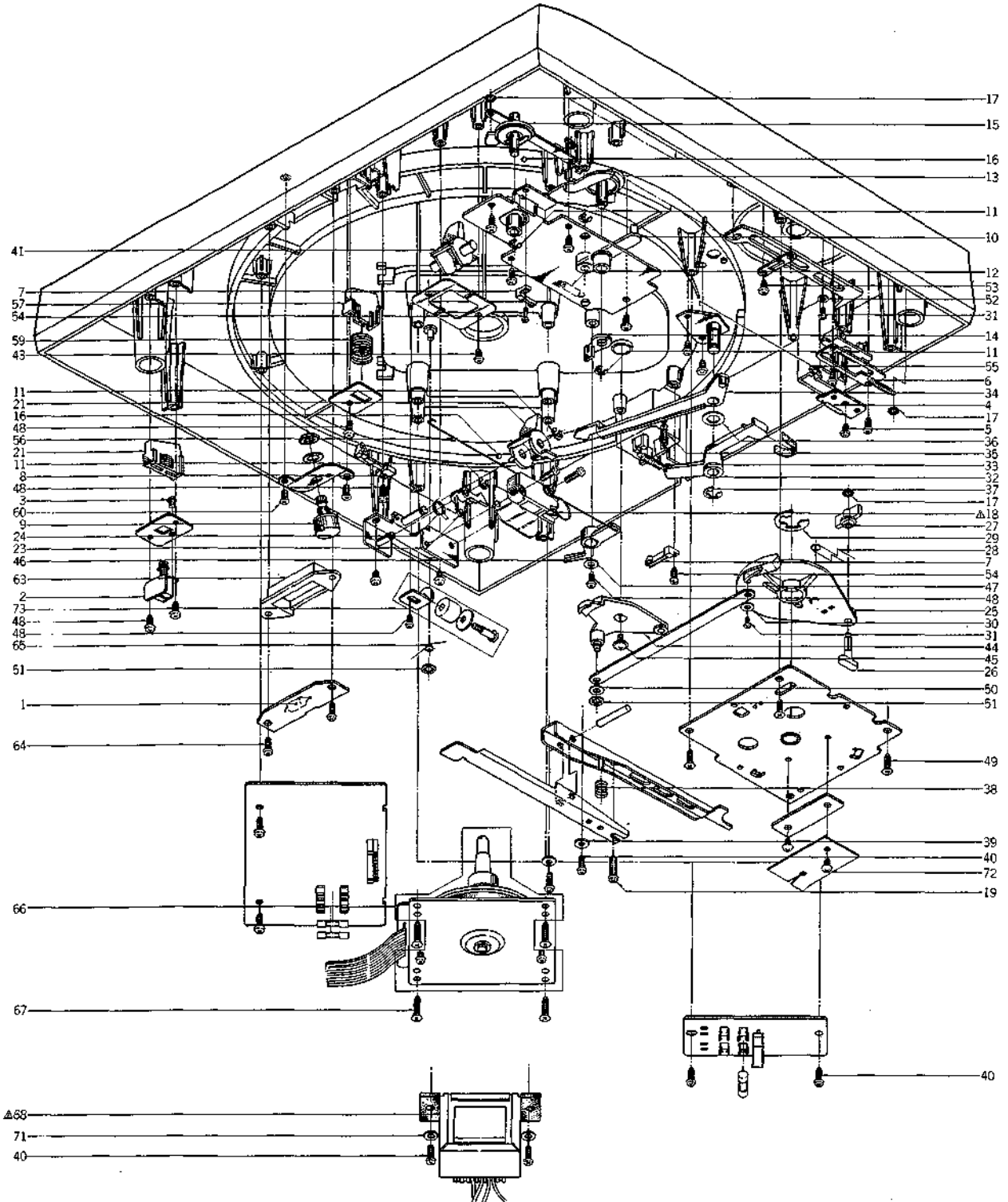

## ASSEMBLY BLOCK (2)

Ref. No.	Parts No.	Description	Schematic No.	Ref. No.	Parts No.	Description	Schematic No.
5-1	EL306690	Δ NL Lead NE-2HH 822/100AC	28-3-9	5-72	ZS325495	T2BR30×06STL CMT	
5-2	ES325493	SW Push SPJ222L 2-02-02S	25-5-362	5-73	EP320723	Plunger Assy NX-9331H	44-1-130
5-3	ZS432843	PAN26×04STL CMT					
5-4	ES651745	SW Reed HR-10L	25-11-2				
5-5	ZS609120	T2PAN30×06STL CMT					
5-6	ZG312981	SP T1-4.0/0.2-18.0 T1-095					
5-7	ES326961	SW Leaf MSW-0026TU 01-1 NO	25-10-43				
5-8	ES325483	SW Leaf MSW-0061BU 01-1 NO	25-10-42				
5-9	EV325494	VR Rotary 16S10×0B B102	36-6-44				
5-10	TP327280	Select Lever	APD-4023				
5-11	ZW270101	Ring E300SUP CMT312981	6-1-9				
5-12	ZG385323	Eject Safety Spring	CS-1025				
5-13	TP327289	Select Cam (A) Part	APD-4029				
5-14	TP327290	Select Cam (B)	APD-4030				
5-15	TP327291	Select Cam (C)	APD-4031				
5-16	MV368886	Ball 300STL					
5-17	ZW340648	Ring CS190STL PKR	6-1-14				
5-18	ES325488	Δ SW Micro K1 UCE	25-1-63				
5-19	ZS422965	PAN30×15STL CMT					
5-20x	ZS302778	PAN30×15PCN					
5-21	SK327303	Power Lever Knob	APD-4039				
5-22x	SK327304	Power Lever Knob (BL)	APD-4039				
5-23	TP327260	Ratchet Lever	APD-4005				
5-24	ZG327297	Coil Spring	APD-4036				
5-25	TP327313	Operation Plate	APD-4048				
5-26	TP327261	Turn Over Shaft	APD-4006				
5-27	TP327263	Turn Over Plate	APD-4007				
5-28	ZG327265	Spring	APD-4009				
5-29	ZW327440	Ring E100SUP CMT	6-1-9				
5-30	ZW268288	PW21×070×025TEF					
5-31	ZS315488	T1PAN20×05STL CMT					
5-32	TP327278	Brake Lever	APD-4021				
5-33	ZG328119	Brake Lever Spring	APD-4055				
5-34	TP327279	Gear Stopper	APD-4022				
5-35	ZG328118	Gear Stopper Spring	APD-4054				
5-36	ZW428725	PW79×130×030NYL					
5-37	ZW270134	Ring E500SUP CMT	6-1-9				
5-38	ZG313209	SP C-5.5/0.8-12.5 C-054					
5-39	ZW556828	PW32×100×050STL CMT					
5-40	ZS321537	PLX PAN30×10STL CMT	7-1-70				
5-41	SK327282	Elevation Lever Knob	APD-4025				
5-42	SK327283	Elevation Lever Knob (BL)	APD-4025				
5-43	ZS310343	PLX PAN30×06STL CMT	7-1-70				
5-44	TP327274	Rotor Cam	APD-4017				
5-45	ZS462194	P2PAN30×08STL CMT PW080					
5-46	TP327276	Repeat Lever	APD-4019				
5-47	ZW556828	PW32×100×50STL CMT					
5-48	ZS322402	PLX PAN30×08STL CMT	7-1-70				
5-49	ZS325524	PT BR30×12STL CMT C	7-1-78				
5-50	ZW259481	PW31×080×030NYL					
5-51	ZW653163	Ring CS280STL PKR	6-1-14				
5-52	ZW300888	PW23×060×040BRS NE3					
5-53	ZS310343	PLX PAN30×06STL CMT	7-1-70				
5-54	ZS608220	PAN26×06STL CMT					
5-55	ZG327264	Select Lever Spring	APD-4008				
5-56	TP327269	Repeat Pole	APD-4013				
5-57	SB325410	Return Button	APD-3017				
5-58x	SB325411	Return Button (BL)	APD-3017				
5-59	ZG316400	Return Spring	AP-1205				
5-60	ZS325525	BT CTS30×10STL CMT	7-1-77				
5-61	SB325416	Speed Change Button	APD-3021				
5-62x	SB325417	Speed Change Button (BL)	APD-3021				
5-63	SZ325419	Lamp House (A)	APD-3023				
5-64	ZS325503	PLX PAN30×12STL CMT	7-1-70				
5-65	ZG325444	Reject Spring	APD-3047				
5-66	BM320724	Motor BLK DDM-6C	9-2-43				
5-67	ZS325523	BT CTS30×16STL CMT	7-1-77				
5-68	BT325486	Δ Trans Power APT30-40 (U/T, CEE, UK, SAA)	38-4-794				
5-69x	BT328576	Δ Trans Power APT30-10 (JPN)	38-4-915				
5-70x	BT325487	Δ Trans Power APT30-30 (CSA, AAL)	38-4-795				
5-71	ZW616004	PW31×080×100STL CMT					

When ordering parts, please quote Parts Number, Description and Model Number.

## 6. FINAL ASSEMBLY BLOCK

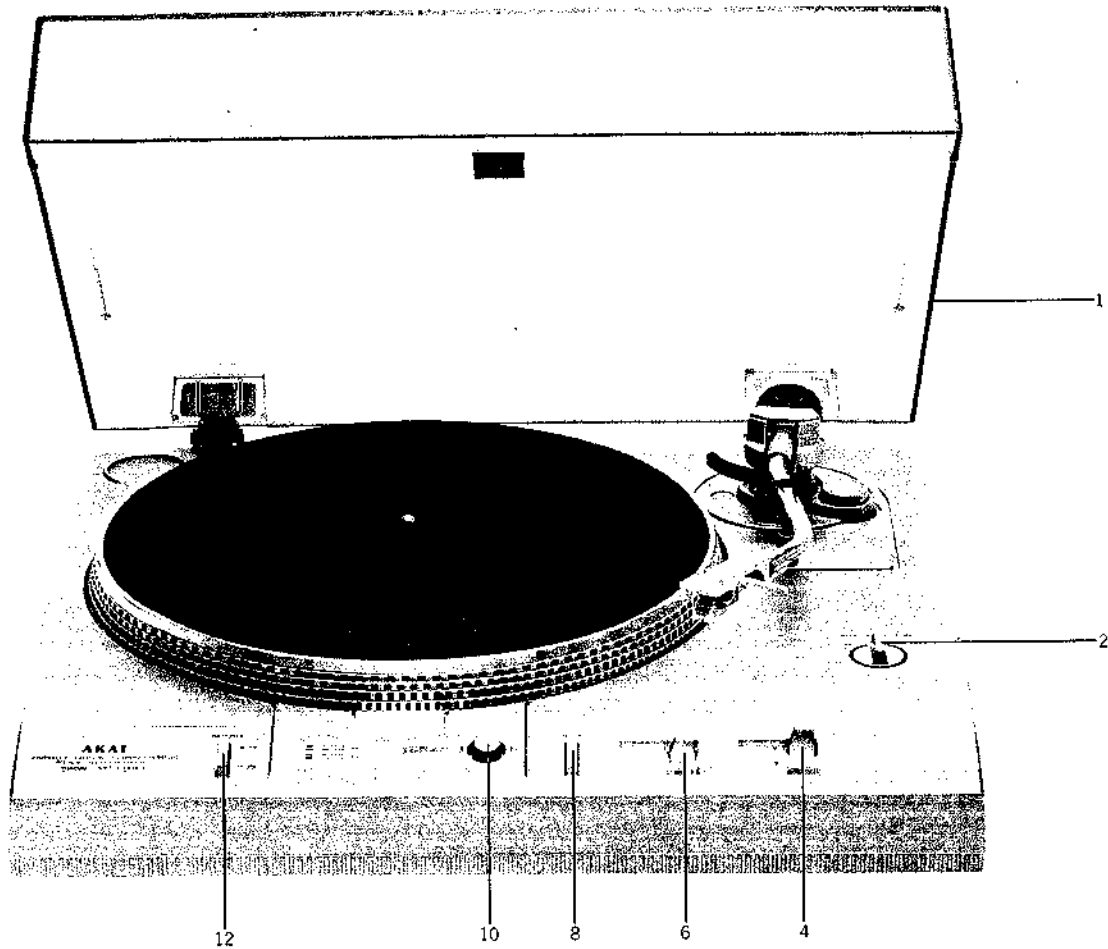

### FINAL ASSEMBLY BLOCK

Ref. No.	Parts No.	Description	Schematic No.
6-1	BC320744	Dust Cover Part AP-D30	2-34-194
6-2	SK327287	Knob	APD-4028
6-3x	SK327288	Knob (BL)	APD-4028
6-4	SK327282	Elevation Lever Knob	APD-4025
6-5x	SK327283	Elevation Lever Knob (BL)	APD-4025
6-6	SK327303	Power Lever Knob	APD-4039
6-7x	SK327304	Power Lever Knob (BL)	APD-4039
6-8	SB325410	Return Button	APD-3017
6-9x	SB325411	Return Button (BL)	APD-3017
6-10	SK325414	Control Knob	APD-3020
6-11x	SK325415	Control Knob (BL)	APD-3020
6-12	SB325416	Speed Change Button	APD-3021
6-13x	SB325417	Speed Change Button (BL)	APD-3021
6-14x	SP325439	Rear Plate	APD-3042
6-15x	SA320746	Insulator Part AP-D30	APD-3043
6-16x	TP327327	Insulator (B) Part AP-D40	APD-3043

When ordering parts, please quote Parts Number, Description and Model Number.

## II. MODEL AP-Q60/C

### 1. RECOMMENDED SPARE PARTS LIST

Because, if the parts listed below are on hand, almost any repair can be accomplished, we suggest that you stock these Recommended Spare Parts Items.

Parts No.	Description	Notes
BA326163	Quartz Servo P.C Board Comp. AP-Q60 (A)	
BA326164	Quartz Servo P.C Board Comp. AP-Q60 (E)	CEE, UK, SAA
BA326162	Quartz Servo P.C Board Comp. AP-Q60 (U)	U/T, CSA
BT325553	△ Trans Power APT50-30	CSA, AAL
BT325552	△ Trans Power APT50-40	U/T, CEE, UK, SAA
EC616342	C S-Fix H CTY122D33 1.5-16	
ED310584	D LED GL-9PR2 RED	
ED321115	D Silicon H LB-5 F10	
ED306724	D Silicon S5277B 100/1.0A	
ED306732	D Silicon S5277D 200/1.0A	
ED323353	D Zener H 05Z12 L	
ED303155	D Zener 05Z5.6 U	
EF300574	△ Fuse EAWK T 250V 0.12A	CEE, UK, SAA
EF300589	△ Fuse EAWK T 250V 0.31A	CEE, UK, SAA
EF695766	△ Fuse Semko T 250V 0.31A	CEE, UK, SAA
EF308933	△ Fuse TSC A 250V 0.20A	U/T
EF309389	△ Fuse TSC A 250V 0.40A	U/T, CSA
EF327103	△ Fuse TSC A 250V 0.50A	U/T
EF315334	△ Fuse TSC 125V 0.25A	AAL
EF308848	△ Fuse TSC 125V 0.40A	AAL
EF309390	△ Fuse TSC 125V 0.50V	AAL
EI325557	IC AP-400-A	
EI322599	IC TA75458S	
EI304657	IC TC4011BP	
EI325556	Photo Sensor NJL5141E-A (A) (B) (C)	
EI324532	X'tal 5.4MHz	
EL325554	NL Lead NE-2HH-D6 103/170DC	
ES326961	SW Leaf MSW-0026TU 01-1 NO	
ES-325483	SW Leaf MSW-0061BU 01-1 NO	
ES325488	△ SW Micro K1 UCE	
ES325493	SW Push SPJ222L 2-02-02S	
ES651745	SW Reed HR-10L	
ET325501	TR 2SA1015 (O) (Y)	
ET306720	TR 2SA966 (O) (Y)	
ET307234	TR 2SC1815 (Y) (GR)	
ET325482	TR 2SC1959 (Y)	
ET310168	TR 2SC2229 (O) (Y)	
ET306719	TR 2SC2236 (O) (Y)	
ET306721	TR 2SC790 (O) (Y)	
EV327391	R S-Fix H D8 3P 504	

Parts No.	Description	Notes
EV638548	R S-Fix H TM10K (PV) 3P 0.50W 203	
EV648527	R S-Fix H V10K8-4-2 3P 204	
EV560136	R S-Fix H V10K8-4-2 3P 203	
EV593368	R S-Fix H V10K8-4-2 3P 303	
EV325555	VR Rotary 16S10x0C B502	
EW313884	△ AC Cord 2 Cores GTBS-2F B	UK
EW313882	△ AC Cord 2 Cores KP-419C, LTCE-2F E	CEE
EW313883	△ AC Cord 2 Cores KP-560, VFSA-2 S	SAA
EW374894	△ AC Cord 2 Cores VM-0129A J	U/T
EW207742	△ AC Cord 2 Cores VM-0238 UC	CSA, AAL

## 2. QUARTZ SERVO P.C BOARD (APQ-5038) COMP.

Symbol No.	Parts No.	Description	Schematic No.
2-1	BA326162	Quartz Servo P.C Board Comp. AP-Q60 (U) (U/T, CSA)	
2-2	BA326163	Quartz Servo P.C Board Comp. AP-Q60 (A)	
2-3	BA326164	Quartz Servo P.C Board Comp. AP-Q60 (E) (CEE, UK, SAA)	
2-IC1	EI304657	IC TC4011BP	45-8-232
2-IC2	EI325557	IC AP-400-A	45-8-435
2-IC3,4	EI322599	IC TA75458S	45-8-415
2-TR1,2	ET307234	TR 2SC1815(Y)(GR)	45-1-299
2-TR3	ET325482	TR 2SC1959(Y)	45-1-385
2-TR4	ET307234	TR 2SC1815(Y)(GR)	45-1-299
2-TR5,6	ET325501	TR 2SA1015(O)(Y)	45-1-328
2-TR7	ET306719	TR 2SC2236(O)(Y)	45-1-307
2-TR8	ET306720	TR 2SA966(O)(Y)	45-1-306
2-TR9	ET306719	TR 2SC2236(O)(Y)	45-1-307
2-TR10	ET306720	TR 2SA966(O)(Y)	45-1-306
2-TR11,12	ET306721	TR 2SC790(O)(Y)	45-1-304
2-TR13	ET306720	TR 2SA966(O)(Y)	45-1-306
2-TR14	ET310168	TR 2SC2229(O)(Y)	45-1-305
2-D1	ED321115	D Silicon H LB-5 F10	45-3-62
2-D2	ED303155	D Zener 05Z5.6 U	45-6-76
2-D3,4	ED323353	D Zener H 05Z12 L	45-6-76
2-D5to8	ED306724	D Silicon S5277B 100/1.0A	45-2-79
2-D9,10	ED306732	D Silicon S5277D 200/1.0A (Ext. AAL)	45-2-80
2-D11	ED321115	D Silicon H LB-5 F10	45-3-62
2-D13	ED321115	D Silicon H LB-5 F10	45-3-62
2-VR1	EV638548	R S-Fix H TM10K (PV) 3P 0.50W 203	36-23-1
2-VR2	EV593368	R S-Fix H V10K8-4-2 3P 303	36-10-250
2-VR3,4	EV560136	R S-Fix H V10K8-4-2 3P 203	36-10-250
2-VR5	EV648527	R S-Fix H V10K-8-4-2 3P 204	36-10-250
2-VR7	EV327391	R S-Fix H D8 3P 504	36-10-280
2-X1	EI324532	X'tal 5.4MHz	53-1-210
2-L1	EO328137	Coil Fix 2 NI-0036 2.20UH	23-1-396
2-VC1	EC616342	C S-Fix H CTY122D33 1.5-16	24-2-32
2-R1	ER327710	R CB H SNP FS RD 1/4W 151J	35-11-30
2-C15,16	EC325559	C SA V FOs 1R5K 25.0DC	24-19-3
2-C23,24	EC316188	C EC V CUT SM 102 25.0DC	24-12-49
2-F3	EF308933	Δ Fuse TSC A 250V 0.20A	39-1-64
2-F3	EF300574	Δ Fuse EAWK T 250V 0.12A (CEE, UK, SAA)	39-1-60
2-F4,5	EF327103	Δ Fuse TSC A 250V 0.50A (U/T)	39-1-64
2-F4,5	EF309390	Δ Fuse TSC 125V 0.50V (AAL)	39-1-65
2-F4,5	EF300589	Δ Fuse EAWK T 250V 0.31A (CEE, UK, SAA)	39-1-60

## 3. FUSE P.C BOARD (APD-3052/APQ-5014/5016/5017) COMP.

Symbol No.	Parts No.	Description	Schematic No.
3-TR1	ET310168	TR 2SC2229(O)(Y)(AAL)	45-1-305
3-D1,2	ED306732	D Silicon S5277D 200/1.0A (AAL)	45-2-80
3-C1	EC302898	Δ C MMY V MDD 473K 630DC (U/T)	24-9-120
3-C1	EC314688	Δ C CE V FZ 103P 125AC (CSA, AAL)	24-5-87
3-C1	EC325485	Δ C MP V 473M 250AC (CEE, UK, SAA)	24-9-134
3-F1,2	EF309389	Δ Fuse TSC A 250V 0.40A (U/T)	39-1-64
3-F1	EF309389	Δ Fuse TSC A 250V 0.40A (CSA)	39-1-64
3-F1	EF308848	Δ Fuse TSC 125V 0.40A (AAL)	39-1-65
3-F1	EF695766	Δ Fuse Semko T 250V 0.31A (CEE, UK, SAA)	39-1-53
3-F2	EF315334	Δ Fuse TSC 125V 0.25A (AAL)	39-1-65

#### 4. ASSEMBLY BLOCK (1)

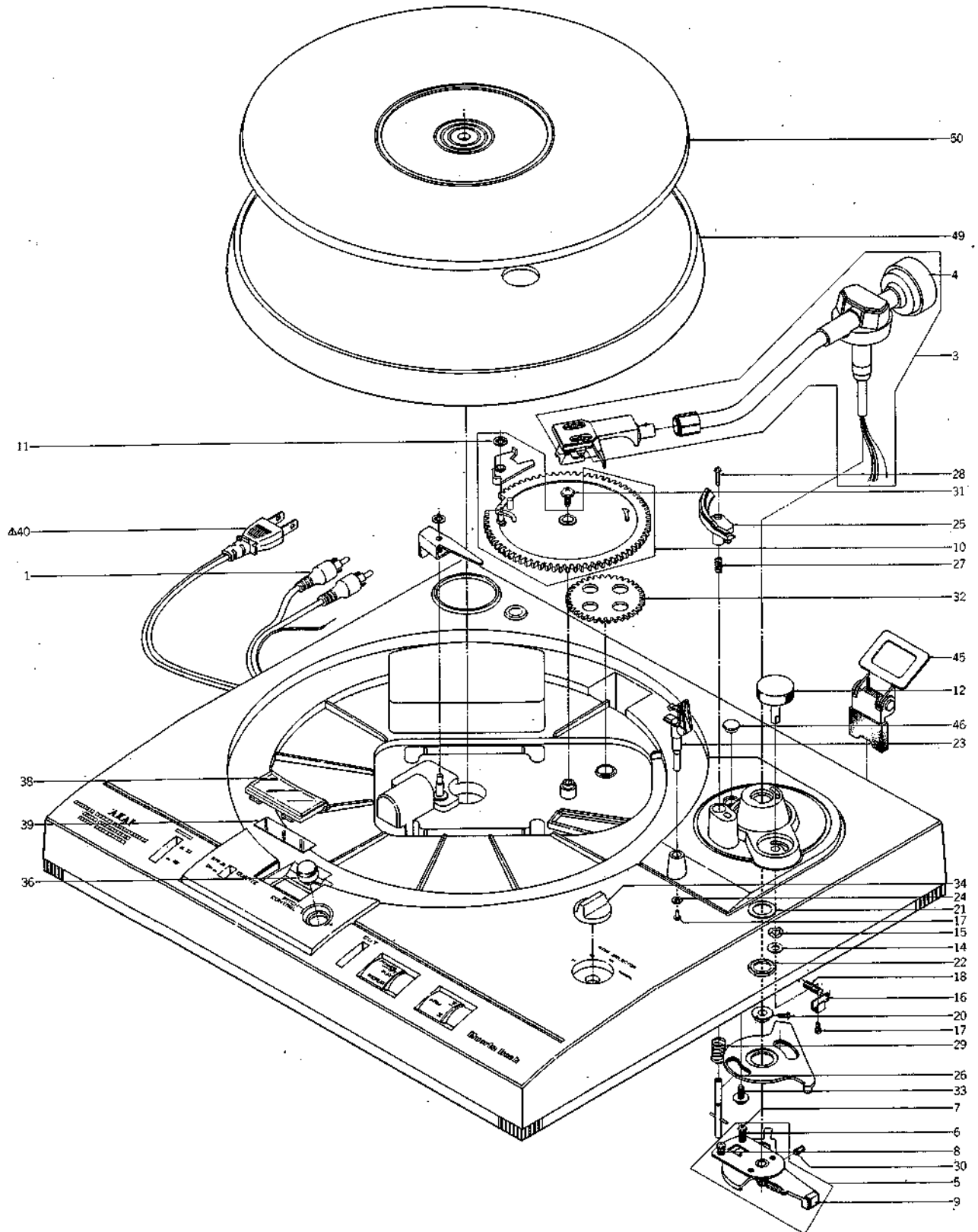

## ASSEMBLY BLOCK (1)

Ref. No.	Parts No.	Description	Schematic No.
4-1	EW325490	Cord P-54-027 2P Audio (Ext. AAL)	26-10-20
4-2x	EW325489	Cord P-54-075 2P Audio (AAL)	26-10-19
4-3	TP320747	Tone Arm Part ARM-30	53-1-185
4-4	TP325499	Main Weight	53-1-185
4-5	TP327663	PU Plate Assy AP-D40	
4-6	ZG312997	SP T1-4.0/0.4-16.0	
4-7	ZS305246	Adjust Screw (B)	AP-00117
4-8	ZG313183	SP C-4.5/0.4-8.0	
4-9	TP302925	Ferrite Magnet	5-1-19
4-10	TP327665	Main Gear Assy AP-D40	
4-11	ZW653163	Ring CS280STL PKR	6-1-14
4-12	SK320740	Canceller Knob Part AP-D30	APD-3050
4-13x	SK320741	Canceller Knob Part AP-D30-BL	APD-3050
4-14	ZW313593	PW51x103x050P BR	
4-15	ZW315478	Wave Washer D5 SUS	
4-16	ML302852	Lever	AP-0020
4-17	ZS669104	T2PAN23x06STL CMT	
4-18	ZG302825	Coil Spring (4)	AP-0021
4-19x	ZG321734	Canceller Spring (AAL)	AP-9047
4-20	ZS590804	PAN23x06STL CMT	
4-21	ZW325517	PW13x200x050STL CMT	
4-22	ZW327271	Arm Fixation Nut	APD-4015
4-23	TP320742	Arm Rest Part AP-D30	APD-3006
4-24	ZW300888	PW23x060x040BRS NI3	
4-25	TP320743	Elevation Arm Part AP-D30	APD-3008
4-26	TP327270	Elevation Shaft Part	APD-4014
4-27	ZG325470	Elevation Hight Adjust Spring	APD-3064
4-28	ZS325520	PAN26x12STL BNI	
4-29	ZG325402	Elevation Spring	APD-3010
4-30	ZS356804	6SET30x040SCM PKR HP	
4-31	ZS327438	PT BR30x10STL CMT C	7-1-78
4-32	TP327275	Sub Gear	APD-4018
4-33	ZS297641	T2BID30x08STL CMT PW100	
4-34	SK327287	Knob	APD-4028
4-35x	SK327288	Knob (BL)	APD-4028
4-36	SK325414	Control Knob	APD-3020
4-37x	SK325415	Control Knob (BL)	APD-3020
4-38	SZ325536	Lamp House (A)	APQ-5004
4-39	TP325539	Strobe Mirror	APQ-5007
4-40	EW374894	Δ AC Cord 2 Cores VM-0129A J (U/T)	26-3-19
4-41x	EW207742	Δ AC Cord 2 Cores VM-0238 UC (CSA, AAL)	26-3-45
4-42x	EW313882	Δ AC Cord 2 Cores KP-419C, LTCE-2FE (CEE)	26-3-66
4-43x	EW313884	Δ AC Cord 2 Cores GTBS-2F B (UK)	26-3-67
4-44x	EW313883	Δ AC Cord 2 Cores KP-560, VFSA-2 S (SAA)	26-3-69
4-45	TP320745	Hinge (D) Part AP-D30	9-4-9
4-46	TP302504	Rubber Bush	AP-0043
4-47x	ZS421740	PAN30x08STL BNI (AAL)	
4-48x	ZW273835	N30BRS NI3 1 (AAL)	
4-49	TP325551	Platter (C)	1-34-6
4-50	TP325443	Table Sheet	APD-3046
4-51x	TP323593	Table Sheet (B) (AAL)	APD-3046



# 5. ASSEMBLY BLOCK (2)

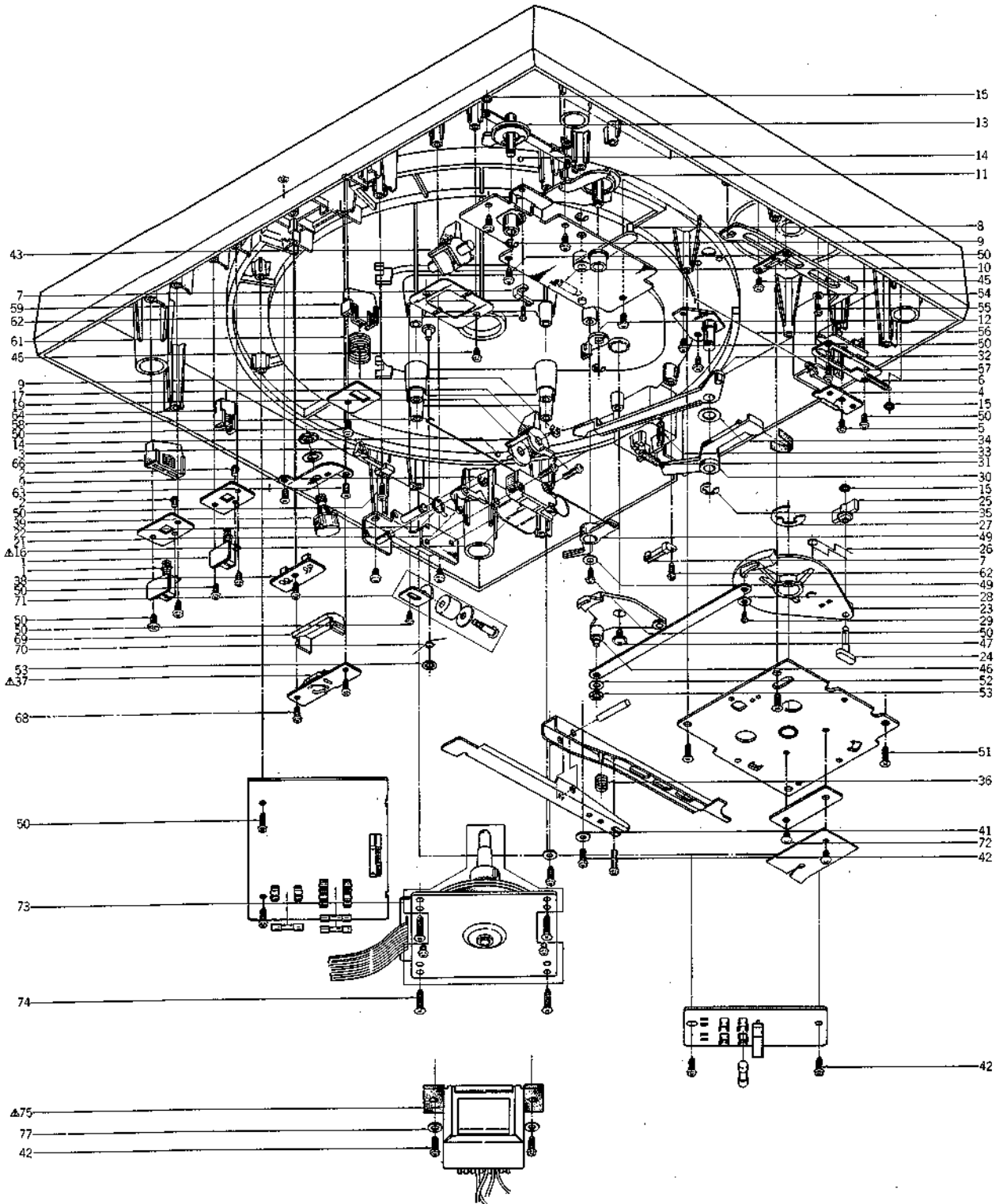

## ASSEMBLY BLOCK (2)

Ref. No.	Parts No.	Description	Schematic No.	Ref. No.	Parts No.	Description	Schematic No.
5-1	ES325493	SW Push SPJ222L 2-02-02S	25-5-362	5-73	BM320724	Motor BLK DDM-6C	9-2-43
5-2	ZS432843	PAN26x04STL CMT		5-74	ZS325523	BT CTS30x16STL CMT	7-1-77
5-3	ES325483	SW Leaf MSW-0061BU 01-1 NO	25-10-42	5-75	BT325552	Δ Trans Power APT50-40	
5-4	ES651745	SW Reed HR-10L	25-11-2			(Ext. CSA, AAL)	38-4-796
5-5	ZS609120	T2PAN30x06STL CMT		5-76x	BT325553	Δ Trans Power APT50-30	
5-6	ZG312981	SP T1-4.0/0.2-18.0 T1-095				(CSA, AAL)	38-4-797
5-7	ES326961	SW Leaf MSW-0026TU 01-1 NO	25-10-43	5-77	ZW616004	PW31x080x100STL CMT	
5-8	TP327280	Select Lever	APD-4023				
5-9	ZW270101	Ring E300SUP CMT312981	6-1-9				
5-10	ZG385323	Eject Safety Spring	CS-1025				
5-11	TP327289	Select Cam (A) Part	APD-4029				
5-12	TP327290	Select Cam (B)	APD-4030				
5-13	TP327291	Select Cam (C)	APD-4031				
5-14	MV368886	Ball 300STL					
5-15	ZW340648	Ring CS190STL PKR	6-1-14				
5-16	ES325488	Δ SW Micro K1 UCE	25-1-63				
5-17	ZS422965	PAN30x15STL CMT					
5-18x	ZS302778	PAN30x15PCN					
5-19	SK327303	Power Lever Knob	APD-4039				
5-20x	SK327304	Power Lever Knob (BL)	APD-4039				
5-21	TP327260	Ratchet Lever	APD-4005				
5-22	ZG327297	Coil Spring	APD-4036				
5-23	TP327313	Operation Plate	APD-4048				
5-24	TP327261	Turn Over Shaft	APD-4006				
5-25	TP327263	Turn Over Plate	APD-4007				
5-26	ZG327265	Spring	APD-4009				
5-27	ZW327440	Ring E100SUP CMT	6-1-9				
5-28	ZW268288	PW21x070x025TEF					
5-29	ZS315488	T1PAN20x05STL CMT					
5-30	TP327278	Brake Lever	APD-4021				
5-31	ZG328119	Brake Lever Spring	APD-4055				
5-32	TP327279	Gear Stopper	APD-4022				
5-33	ZG328118	Gear Stopper Spring	APD-4054				
5-34	ZW428725	PW79x130x030NYL					
5-35	ZW270134	Ring E500SUP CMT	6-1-9				
5-36	ZG313209	SP C-5.5/0.8-12.5 C-054					
5-37	EL325554	Δ NL Lead NE-2HH-D6 103/170DC	28-3-10				
5-38	ED310584	D LED GL-9PR2 RED	45-15-21				
5-39	EV325555	VR Rotary 16S10x0C B502	36-6-45				
5-40x	EI325556	Photo Sensor NLS141E-A(A)(B)(C)	45-18-3				
5-41	ZW556828	PW32x100x050STL CMT					
5-42	ZS321537	PLX PAN30x10STL CMT	7-1-70				
5-43	SK327282	Elevation Lever Knob	APD-4025				
5-44x	SK327283	Elevation Lever Knob (BL)	APD-4025				
5-45	ZS310343	PLX PAN30x06STL CMT	7-1-70				
5-46	TP327274	Rotor Cam	APD-4017				
5-47	ZS462194	P2PAN30x08STL CMT PW080					
5-48	TP327276	Repeat Lever	APD-4019				
5-49	ZW556828	PW32x100x050STL CMT					
5-50	ZS322402	PLX PAN30x08STL CMT	7-1-70				
5-51	ZS325524	PT BR30x12STL CMT C	7-1-78				
5-52	ZW259481	PW31x080x030NYL					
5-53	ZW653163	Ring CS280STL PKR	6-1-14				
5-54	ZW300888	PW23x060x040BRS NI3					
5-55	ZS315488	T1PAN20x05STL CMT					
5-56	ZG327264	Select Lever Spring	APD-4008				
5-57	ZS608220	PAN26x06STL CMT					
5-58	TP327269	Repeat Pole	APD-4013				
5-59	SB325410	Return Button	APD-3017				
5-60x	SB325411	Return Button (BL)	APD-3017				
5-61	ZG316400	Return Spring	AP-1105				
5-62	ZS327439	PLX PAN26x08STL CMT	7-1-70				
5-63	ZS325525	BT CTS30x10STL CMT	7-1-77				
5-64	SB325534	Quartz Lock Button	APQ-5003				
5-65x	SB325535	Quartz Lock Button (BL)	APQ-5003				
5-66	SB325416	Speed Change Button	APD-3021				
5-67x	SB325417	Speed Change Button (BL)	APD-3021				
5-68	ZS325503	PLX PAN30x12STL CMT	7-1-70				
5-69	SZ325537	Lamp House (B)	APQ-5005				
5-70	ZG325444	Reject Spring	APD-3047				
5-71	EP320723	Plunger Assy NX-9331H	44-1-130				
5-72	ZS325495	T2BR30x06STL CMT					

When ordering parts, please quote Parts Number, Description and Model Number.

## 6. FINAL ASSEMBLY BLOCK

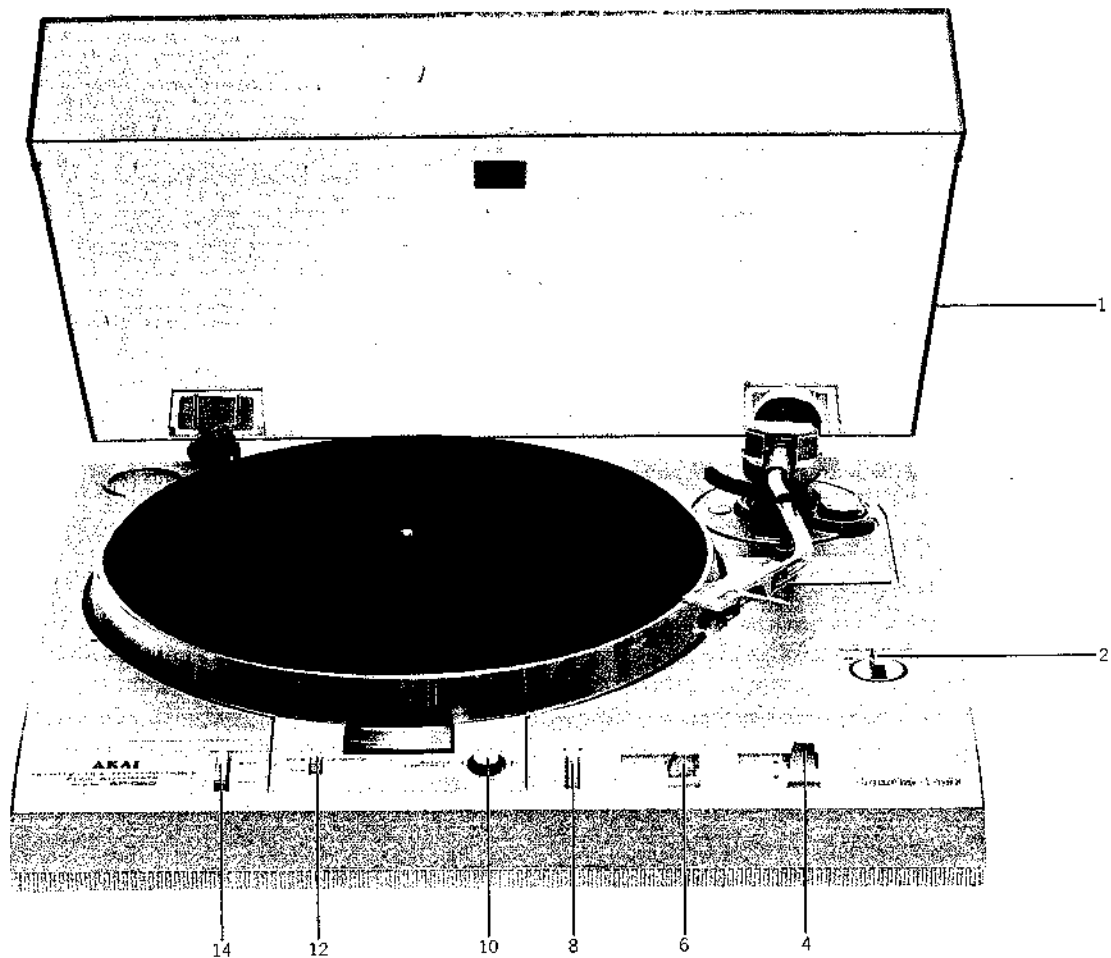

### FINAL ASSEMBLY BLOCK

Ref. No.	Parts No.	Description	Schematic No.
6-1	BC320744	Dust Cover Part AP-D30	2-34-194
6-2	SK327287	Knob	APD-4028
6-3x	SK327288	Knob (BL)	APD-4028
6-4	SK327282	Elevation Lever Knob	APD-4025
6-5x	SK327283	Elevation Lever Knob (BL)	APD-4025
6-6	SK327303	Power Lever Knob	APD-4039
6-7x	SK327304	Power Lever Knob (BL)	APD-4039
6-8	SB325410	Return Button	APD-3017
6-9x	SB325411	Return Button (BL)	APD-3017
6-10	SK325414	Control Knob	APD-3020
6-11x	SK325415	Control Knob (BL)	APD-3020
6-12	SB325534	Quartz Lock Button	APQ-5003
6-13x	SB325535	Quartz Lock Button (BL)	APQ-5003
6-14	SB325416	Speed Change Button	APD-3021
6-15x	SB325417	Speed Change Button (BL)	APD-3021
6-16x	SP325439	Rear Plate	APD-3042
6-17x	SA320746	Insulator Part AP-D30	APD-3043
6-18x	TP327327	Insulator (B) Part AP-D40	APD-3043

When ordering parts, please quote Parts Number, Description and Model Number.

# INDEX

## 1. MODEL AP-D40/C

Parts No.	Ref. No. & Symbol No.	Parts No.	Ref. No. & Symbol No.	Parts No.	Ref. No. & Symbol No.	Parts No.	Ref. No. & Symbol No.
BA327659	2-1	SK327287	4-35	ZW270101	5-11		
BA327660	2-2	SK327287	6-2	ZW270134	5-37		
BA327661	2-3	SK327288	4-36x	ZW273835	4-51x		
BC320744	6-1	SK327288	6-3x	ZW300888	4-25		
BM320724	5-66	SK327303	5-21	ZW300888	5-52		
BT325486	5-68	SK327303	6-6	ZW313593	4-15		
BT325487	5-70x	SK327304	5-22x	ZW315478	4-16		
BT328576	5-69x	SK327304	6-7x	ZW325517	4-22		
EC302898	3-C1	SP325439	6-14x	ZW327271	4-23		
EC314688	3-C1	SZ325419	5-63	ZW327440	5-29		
EC316188	2-C13	TP302504	4-40	ZW340648	5-17		
EC317650	2-C5	TP302925	4-10	ZW428725	5-36		
EC321302	3-C1	TP320742	4-24	ZW556828	5-39		
EC325485	3-C1	TP320743	4-26	ZW556828	5-47		
EC325497	2-C6,7	TP320745	4-39	ZW616004	5-71		
ED306724	2-D3to6	TP320747	4-4	ZW653163	4-12		
ED321115	2-D1	TP323593	4-43x	ZW653163	5-51		
ED322774	2-D2	TP325443	4-42				
EF305703	2-F3,4	TP325499	4-5				
EF305703	3-F1	TP325522	4-41				
EF306124	2-F3,4	TP327260	5-23				
EF309389	3-F1,2	TP327261	5-26				
EF593706	3-F1	TP327263	5-27				
EF668474	2-F3,4	TP327269	5-56				
EI322599	2-IC1,2	TP327270	4-27				
EL306690	5-1	TP327274	5-44				
EP320723	5-73	TP327275	4-33				
ER304256	2-R37	TP327276	5-46				
ER308849	2-R25	TP327278	5-32				
ER308849	2-R38	TP327279	5-34				
ER314983	3-R2	TP327280	5-10				
ES325483	5-8	TP327289	5-13				
ES325488	5-18	TP327290	5-14				
ES325493	5-2	TP327291	5-15				
ES326961	5-7	TP327313	5-25				
ES651745	5-4	TP327327	6-16x				
ET306705	2-TR1to4	TP327663	4-6				
ET306705	2-TR7	TP327665	4-11				
ET306705	2-TR10	ZG302825	4-19				
ET306719	2-TR11	ZG312981	5-6				
ET306719	2-TR13	ZG312997	4-7				
ET306720	2-TR12	ZG313183	4-9				
ET306720	2-TR14	ZG313209	5-38				
ET325482	2-TR6	ZG316400	5-59				
ET325501	2-TR5	ZG321734	4-20x				
ET325501	2-TR8	ZG325402	4-30				
EV325494	5-9	ZG325444	5-65				
EV499364	2-VR1,2	ZG325470	4-28				
EV499882	2-VR5	ZG327264	5-55				
EV560136	2-VR3,4	ZG327265	5-28				
EW207742	4-46x	ZG327297	5-24				
EW302795	4-3x	ZG328118	5-35				
EW306427	4-45x	ZG328119	5-33				
EW313882	4-47x	ZG385323	5-12				
EW313883	4-49x	ZS297641	4-34				
EW313884	4-48x	ZS302778	5-20x				
EW325489	4-2x	ZS305246	4-8				
EW325490	4-1	ZS310343	5-43				
EW374894	4-44	ZS310343	5-53				
ML302852	4-17	ZS315488	5-31				
MV368886	5-16	ZS321537	5-40				
SA320746	6-15x	ZS322402	5-48				
SB325410	5-57	ZS325495	5-72				
SB325410	6-8	ZS325503	5-64				
SB325411	5-58x	ZS325520	4-29				
SB325411	6-9x	ZS325523	5-67				
SB325416	5-61	ZS325524	5-49				
SB325416	6-12	ZS325525	5-60				
SB325417	5-62x	ZS327438	4-32				
SB325417	6-13x	ZS356804	4-31				
SK320740	4-13	ZS421740	4-50x				
SK320741	4-14x	ZS422965	5-19				
SK325414	4-37	ZS432843	5-3				
SK325414	6-10	ZS462194	5-45				
SK325415	4-38x	ZS590804	4-21				
SK325415	6-11x	ZS608220	5-54				
SK327282	5-41	ZS609120	5-5				
SK327282	6-4	ZS669104	4-18				
SK327283	5-42	ZW259481	5-50				
SK327283	6-5x	ZW268288	5-30				

# INDEX

## 2. MODEL AP-Q60/C

Parts No.	Ref. No. & Symbol No.	Parts No.	Ref. No. & Symbol No.	Parts No.	Ref. No. & Symbol No.	Parts No.	Ref. No. & Symbol No.
BA326162	2-1	SB325417	5-67x	ZS325495	5-72		
BA326163	2-2	SB325417	6-15x	ZS325503	5-68		
BA326164	2-3	SB325534	5-64	ZS325520	4-28		
BC320744	6-1	SB325534	6-12	ZS325523	5-74		
BM320724	5-73	SB325535	5-65x	ZS325524	5-51		
BT325552	5-75	SB325535	6-13x	ZS325525	5-63		
BT325553	5-76x	SK320740	4-12	ZS327438	4-31		
EC302898	3-C1	SK320741	4-13x	ZS327439	5-62		
EC314688	3-C1	SK325414	4-36	ZS356804	4-30		
EC316188	2-C23,24	SK325414	6-10	ZS421740	4-47x		
EC325485	3-C1	SK325415	4-37x	ZS422965	5-17		
EC325559	2-C15,16	SK325415	6-11x	ZS432843	5-2		
EC616342	2-VC1	SK327282	5-43	ZS462194	5-47		
ED303155	2-D2	SK327282	6-4	ZS590804	4-20		
ED306724	2-D5to8	SK327283	5-44x	ZS608220	5-57		
ED306732	2-D9,10	SK327283	6-5x	ZS609120	5-5		
ED306732	3-D1,2	SK327287	4-34	ZS669104	4-17		
ED310584	5-38	SK327287	6-2	ZW259481	5-52		
ED321115	2-D1	SK327288	4-35x	ZW268288	5-28		
ED321115	2-D11	SK327288	6-3x	ZW270101	5-9		
ED321115	2-D13	SK327303	5-19	ZW270134	5-35		
ED323353	2-D3,4	SK327303	6-6	ZW273835	4-48x		
EF300574	2-F3	SK327304	5-20x	ZW300888	4-24		
EF300589	2-F4,5	SK327304	6-7x	ZW300888	5-54		
EF308848	3-F1	SP325439	6-16x	ZW313593	4-14		
EF308933	2-F3	SZ325536	4-38	ZW315478	4-15		
EF309389	3-F1,2	SZ325537	5-69	ZW325517	4-21		
EF309389	3-F1	TP302504	4-46	ZW327271	4-22		
EF309390	2-F4,5	TP302925	4-9	ZW327440	5-27		
EF315334	3-F2	TP320742	4-23	ZW340648	5-15		
EF327103	2-F4,5	TP320743	4-25	ZW428725	5-34		
EF695766	3-F1	TP320745	4-45	ZW556828	5-41		
EI304657	2-IC1	TP320747	4-3	ZW556828	5-49		
EI322599	2-IC3,4	TP323593	4-51x	ZW616004	5-77		
EI324532	2-X1	TP325443	4-50	ZW653163	4-11		
EI325556	5-40x	TP325499	4-4	ZW653163	5-53		
EI325557	2-IC2	TP325539	4-39				
EL325554	5-37	TP325551	4-49				
EO328137	2-L1	TP327260	5-21				
EP320723	5-71	TP327261	5-24				
ER327710	2-R1	TP327263	5-25				
ES325483	5-3	TP327269	5-58				
ES325488	5-16	TP327270	4-26				
ES325493	5-1	TP327274	5-46				
ES326961	5-7	TP327275	4-32				
ES651745	5-4	TP327276	5-48				
ET306719	2-TR7	TP327278	5-30				
ET306719	2-TR9	TP327279	5-32				
ET306720	2-TR8	TP327280	5-8				
ET306720	2-TR10	TP327289	5-11				
ET306720	2-TR13	TP327290	5-12				
ET306721	2-TR11,12	TP327291	5-13				
ET307234	2-TR1,2	TP327313	5-23				
ET307234	2-TR4	TP327327	6-18x				
ET310168	2-TR14	TP327663	4-5				
ET310168	3-TR1	TP327665	4-10				
ET325482	2-TR3	ZG302825	4-18				
ET325501	2-TR5,6	ZG312981	5-6				
EV325555	5-39	ZG312997	4-6				
EV327391	2-VR7	ZG313183	4-8				
EV560136	2-VR3,4	ZG313209	5-36				
EV593368	2-VR2	ZG316400	5-61				
EV638548	2-VR1	ZG321734	4-19x				
EV648527	2-VR5	ZG325402	4-29				
EW207742	4-41x	ZG325444	5-70				
EW313882	4-42x	ZG325470	4-27				
EW313883	4-44x	ZG327264	5-56				
EW313884	4-43x	ZG327265	5-26				
EW325489	4-2x	ZG327297	5-22				
EW325490	4-1	ZG328118	5-33				
EW374894	4-40	ZG328119	5-31				
ML302852	4-16	ZG385323	5-10				
MV368886	5-14	ZS297641	4-33				
SA320746	6-17x	ZS302778	5-18x				
SB325410	5-59	ZS305246	4-7				
SB325410	6-8	ZS310343	5-45				
SB325411	5-60x	ZS315488	5-29				
SB325411	6-9x	ZS315488	5-55				
SB325416	5-66	ZS321537	5-42				
SB325416	6-14	ZS322402	5-50				

---

SECTION 3

**SCHEMATIC DIAGRAM**

1. SCHEMATIC DIAGRAM OF ICs
2. AP-D40/C NO. 1601430A SCHEMATIC DIAGRAM
3. AP-Q60/C NO. 1601431A SCHEMATIC DIAGRAM

AP-400-A

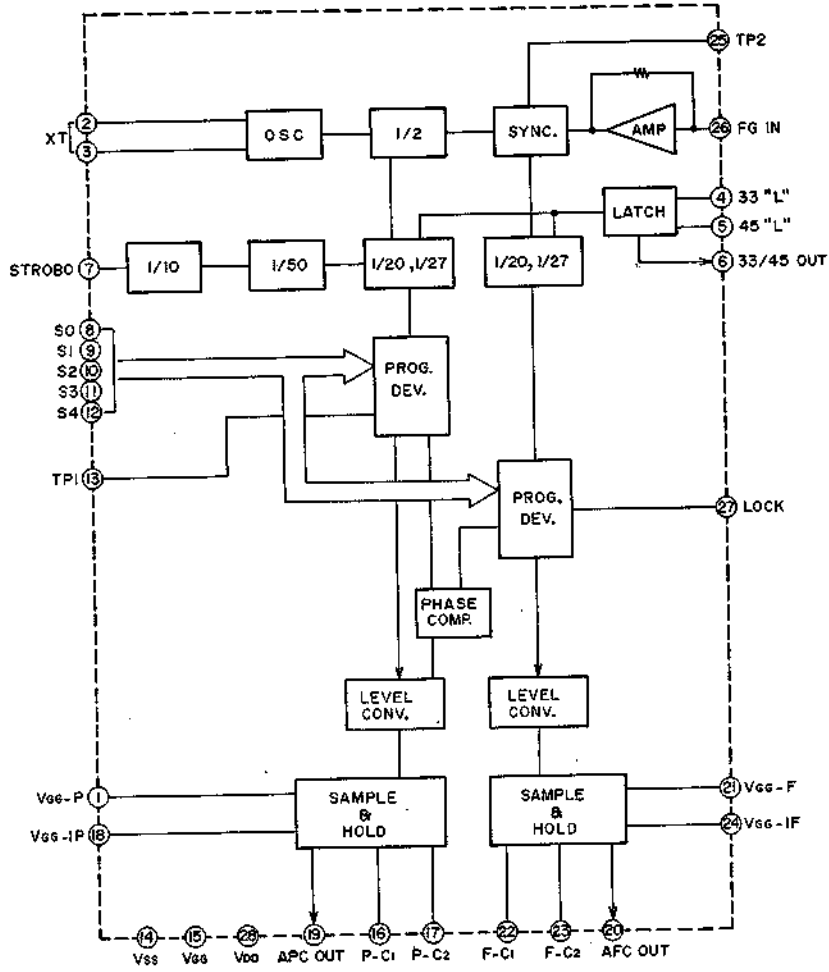

TA75458S

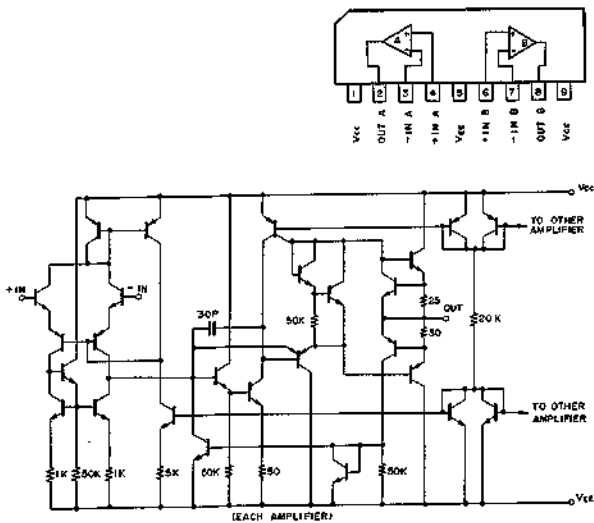

TC4011BP

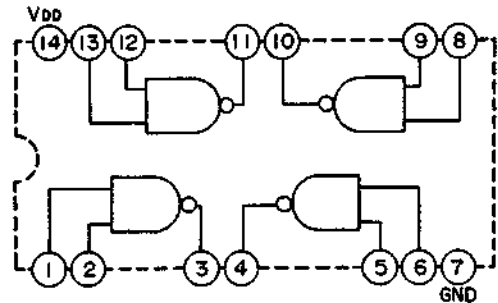

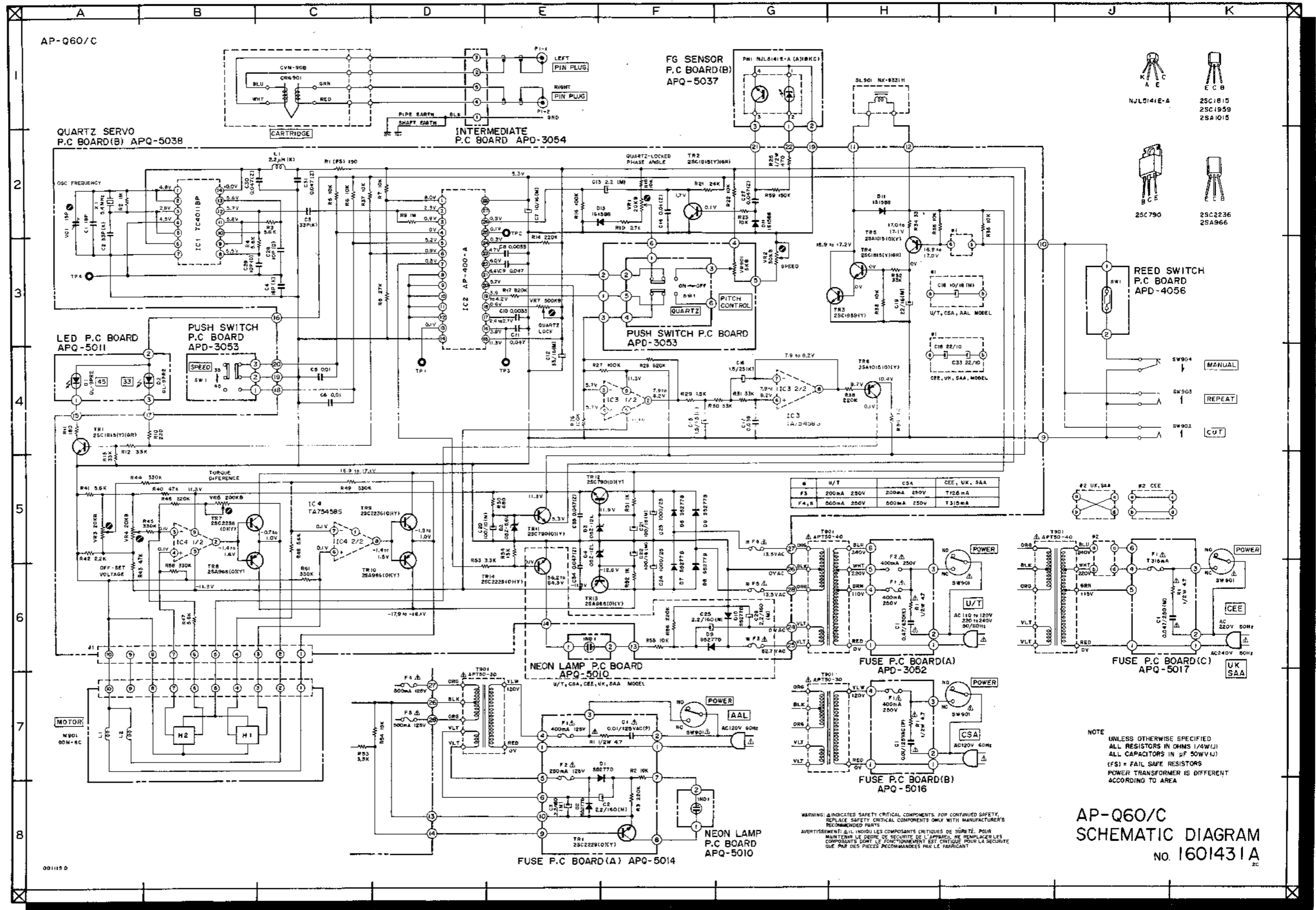

00115 D

2C



AP-D40/C

INTERMEDIATE P.C BOARD  
APD-3054

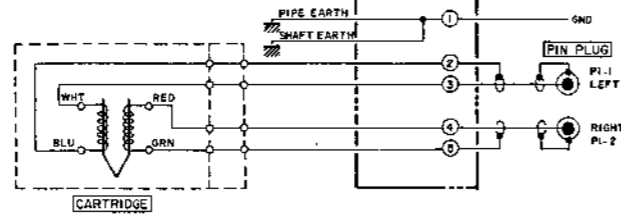

PUSH SWITCH P.C BOARD  
APD-3053

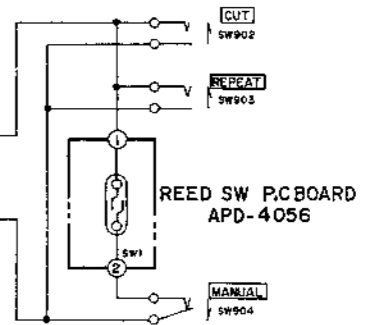
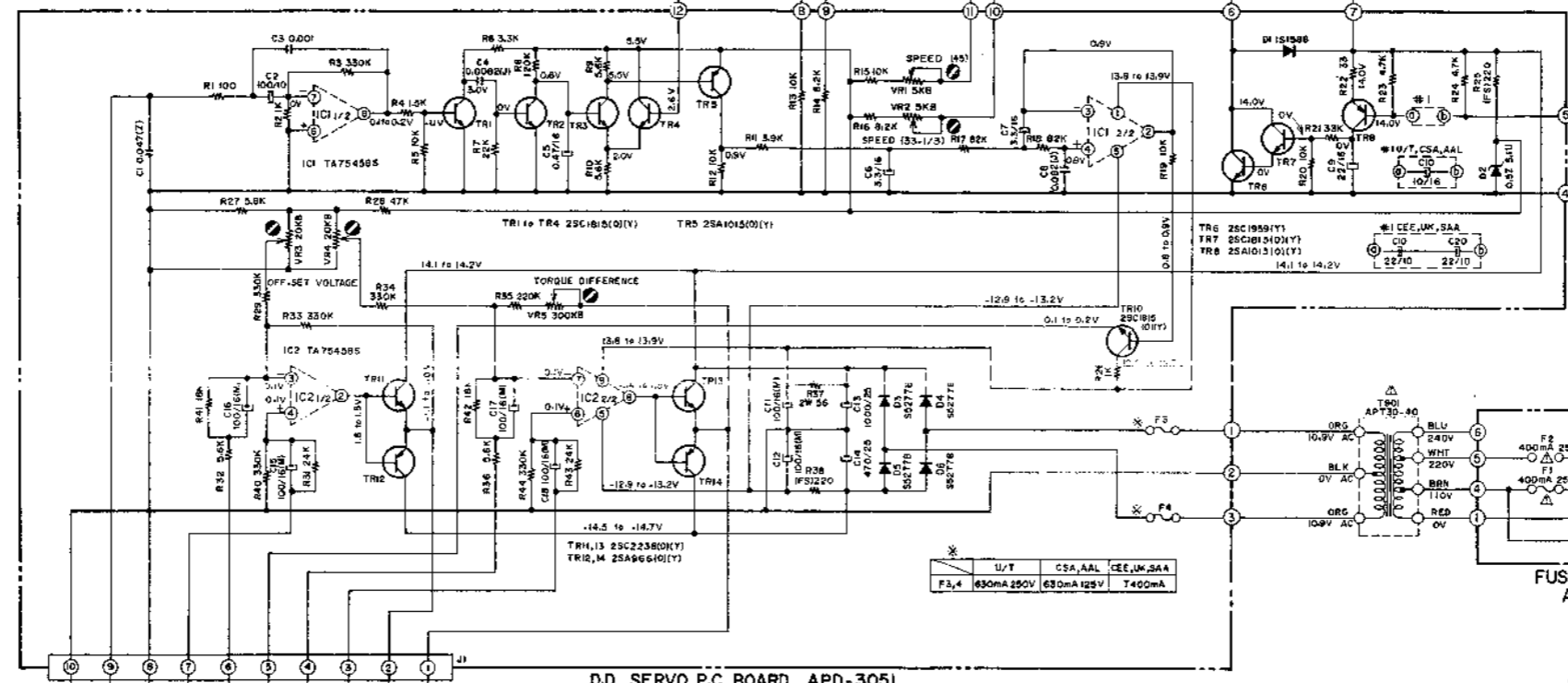
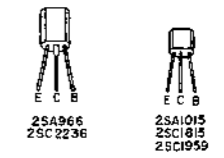
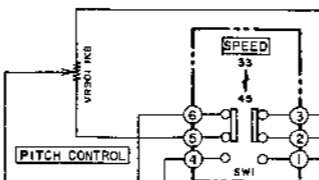

FUSE P.C BOARD (A) APD-3052

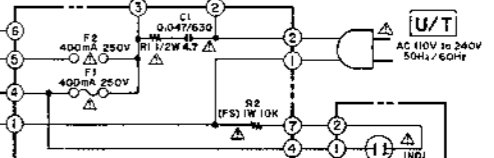

NEON LAMP P.C BOARD APD-3056

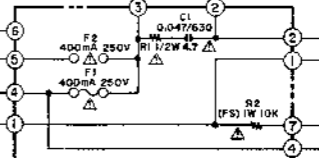

D.D. SERVO P.C BOARD APD-3051

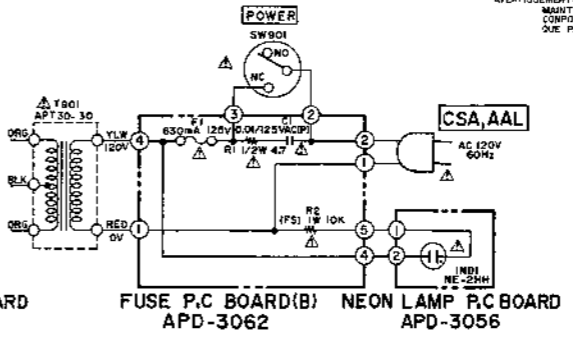
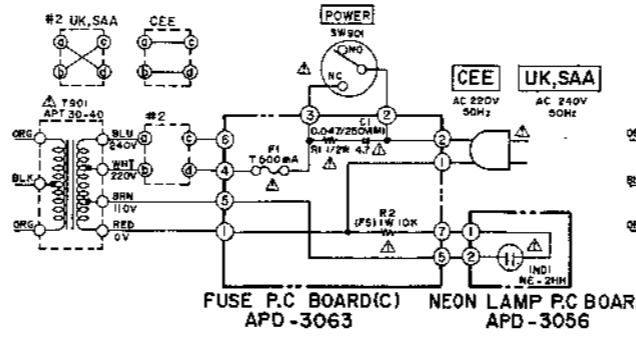
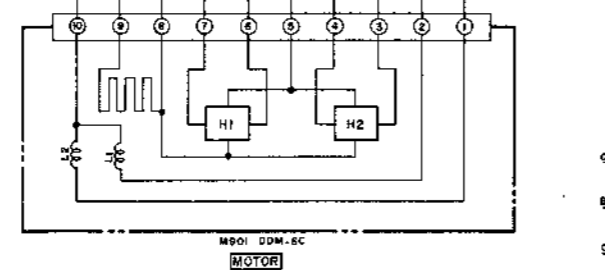

	U/T	CSA,AAL	CEE,UK,SAA
F3,4	630mA 250V	630mA 125V	T400mA

WARNING: Δ INDICATES SAFETY CRITICAL COMPONENTS. FOR CONTINUED SAFETY, REPLACE SAFETY CRITICAL COMPONENTS ONLY WITH MANUFACTURER'S RECOMMENDED PARTS.  
 AVERTISSEMENT: Δ INDIQUE LES COMPOSANTS CRITIQUES DE SÛRETÉ. POUR MAINTENIR LE DEGRÉ DE SÛRETÉ DE L'APPAREIL, NE REMPLACEZ LES COMPOSANTS DONT LE FONCTIONNEMENT EST CRITIQUE POUR LA SÛRETÉ QUE PAR DES PIÈCES RECOMMANDÉES PAR LE FABRICANT.

NOTE  
 UNLESS OTHERWISE SPECIFIED  
 ALL RESISTORS IN OHMS 1/4W (1)  
 ALL CAPACITORS IN μF 50 WV (K)  
 (FS) = FAIL SAFE RESISTORS  
 POWER TRANSFORMER IS DIFFERENT  
 ACCORDING TO AREA

AP-D40/C  
 SCHEMATIC DIAGRAM  
 no. 1601430A

AP-D40/C

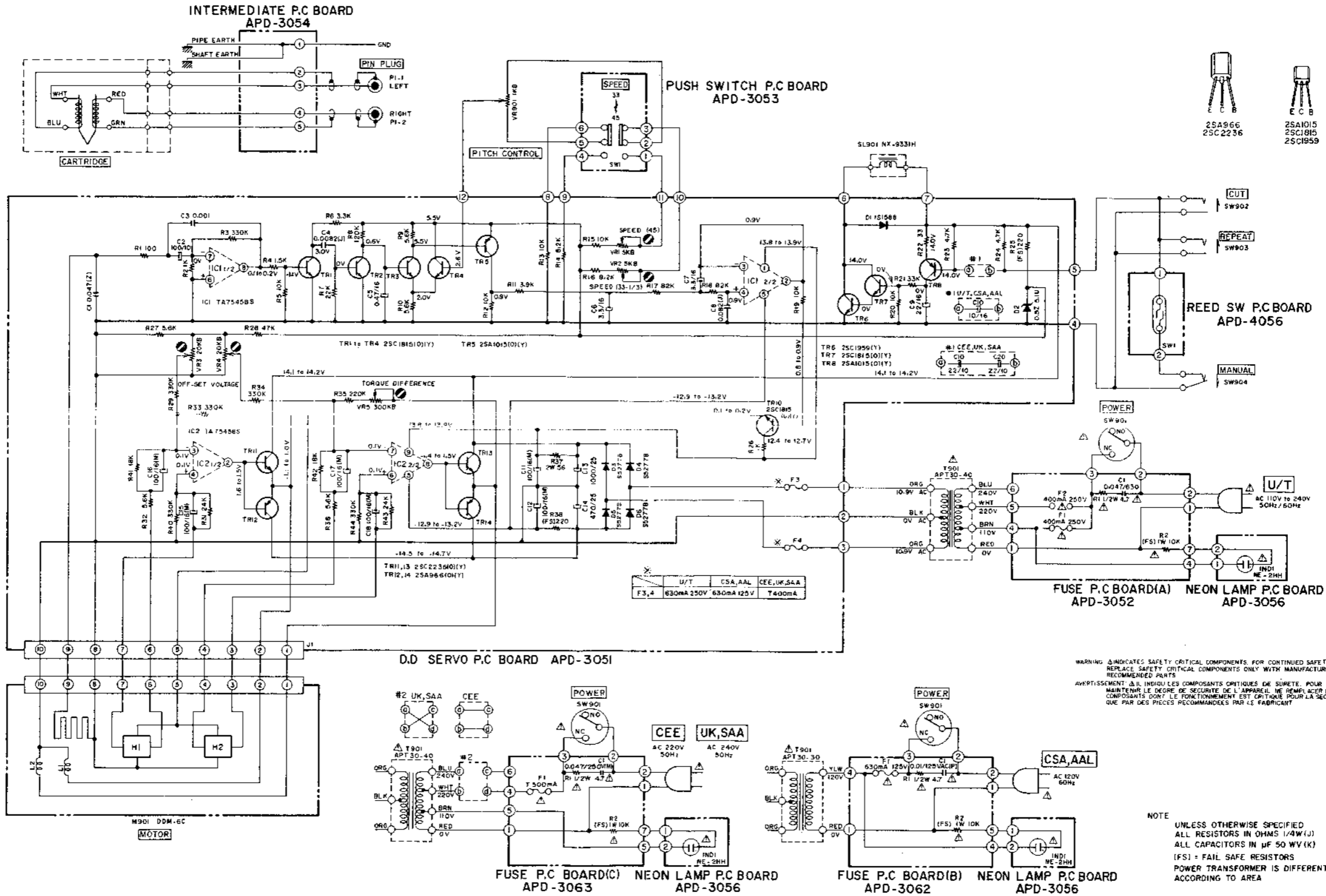

AP-D40/C  
SCHEMATIC DIAGRAM  
No. 1601430A

MODEL AP-D40/C COMPOSITION OF VARIOUS P.C BOARDS

D.D SERVO P.C BOARD APD-3051, PUSH SWITCH P.C BOARD APD-3053 and REED SWITCH P.C BOARD APD-4056 (2ED)

FUSE P.C BOARD (C) APD-3063 and NEON LAMP P.C BOARD APD-3056 (CEE, UK, SAA)

