

AKAI SERVICE MANUAL

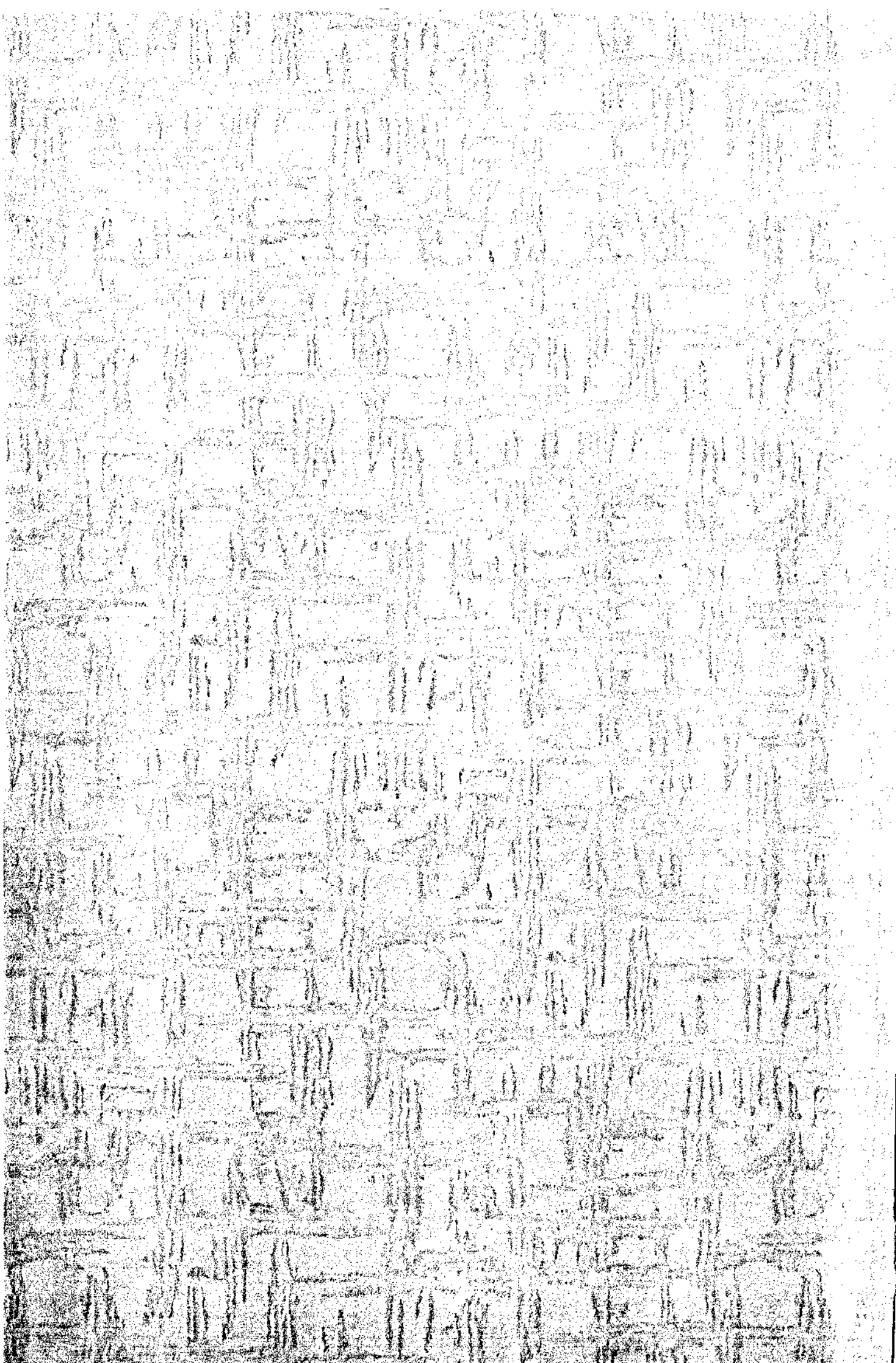

STEREO INTEGRATED AMPLIFIER

MODEL AM-U310



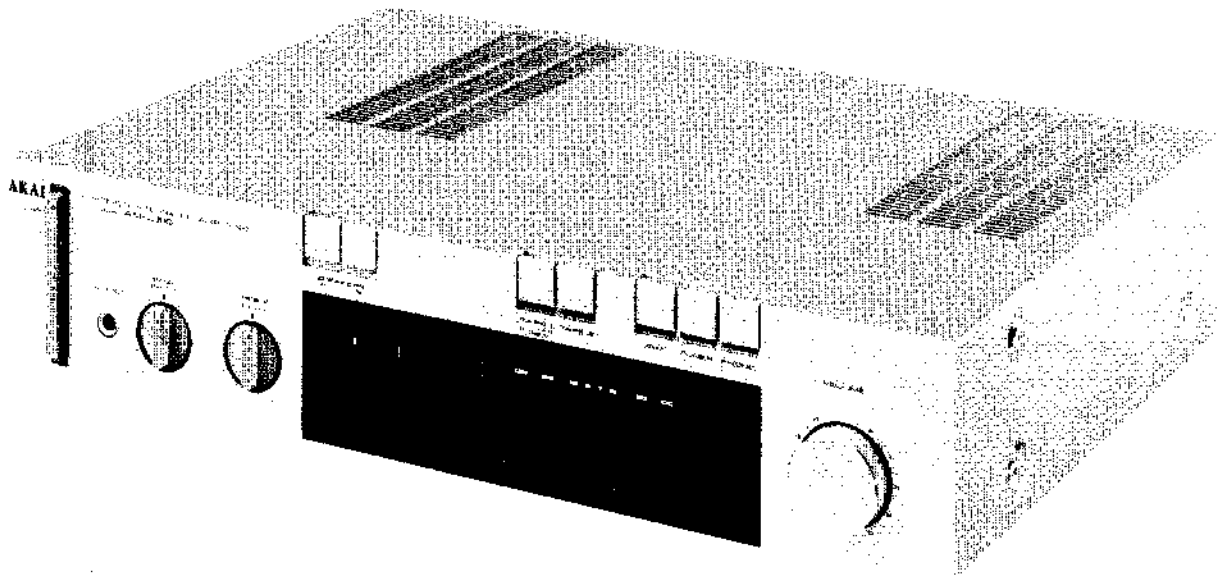

STEREO INTEGRATED AMPLIFIER

MODEL AM-U310

THIS MODEL IS APPLICABLE TO BOTH SILVER
AND PEARL SHADOW PANEL MODELS

SECTION 1	SERVICE MANUAL	3
SECTION 2	PARTS LIST	19
SECTION 3	SCHEMATIC DIAGRAM	26

SAFETY INSTRUCTIONS

SAFETY CHECK AFTER SERVICING

Confirm the specified insulation resistance between power cord plug prongs and externally exposed parts of the set is greater than 10 Mohms, but for equipment with external antenna terminals (tuner, receiver, etc.) and is intended for **C** or **A**, specified insulation resistance should be more than 2.2 Mohms (ground terminals, microphone jacks, headphone jacks, line-in-out jacks etc.)

PRECAUTIONS DURING SERVICING

1. Parts identified by the **Δ** symbol parts are critical for safety.
Replace only with parts number specified.
2. In addition to safety, other parts and assemblies are specified for conformance with such regulations as those applying to spurious radiation. These must also be replaced only with specified replacements.
Examples: RF converters, tuner units, antenna selector switches, RF cables, noise blocking capacitors, noise blocking filters, etc.
3. Use specified internal wiring. Note especially:
 - 1) Wires covered with PVC tubing
 - 2) Double insulated wires
 - 3) High voltage leads
4. Use specified insulating materials for hazardous live parts. Note especially:
 - 1) Insulation Tape
 - 2) PVC tubing
 - 3) Spacers (Insulating Barriers)
 - 4) Insulation sheets for transistors
5. When replacing AC primary side components (transformers, power cords, noise blocking capacitors, etc.), wrap ends of wires securely about the terminals before soldering.

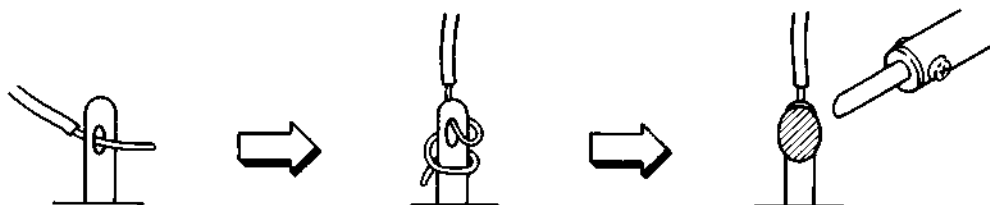

6. Observe that wires do not contact heat producing parts (heatsinks, oxide metal film resistors, fusible resistors, etc.).
7. Check that replaced wires do not contact sharp edged or pointed parts.
8. Also check areas surrounding repaired locations.
9. Use care that foreign objects (screws, solder droplets, etc.) do not remain inside the set.

SECTION 1

SERVICE MANUAL

TABLE OF CONTENTS

I. SPECIFICATIONS	4
II. DISMANTLING OF UNIT	5
III. CONTROLS	6
IV. PRINCIPAL PARTS LOCATION	7
V. VOLTAGE CONVERSION	8
VI. ADJUSTMENT	9
VII. CLASSIFICATION OF VARIOUS P.C BOARDS	10
1. P.C BOARD TITLES AND IDENTIFICATION NUMBERS	10
2. COMPOSITION OF VARIOUS P.C BOARDS	11

For basic adjustments, measuring methods, and operating principles, refer to GENERAL TECHNICAL MANUAL.

I. SPECIFICATIONS

RATED POWER OUTPUT (Both Channels Driven) 20 Hz to 20 kHz, 8 ohms 20 Hz to 20 kHz, 4 ohms	40W × 2/0.03% 50W × 2/0.06%
POWER BANDWIDTH (IHF -3 dB, 8 ohms)	5 Hz to 60 kHz (0.1%)
SIGNAL TO NOISE RATIO (IHF-A) PHONO to SPEAKER TUNER, AUX, TAPE 1, 2 to SPEAKER	80 dB 100 dB
RESIDUAL NOISE (8 ohms)	150 μV
CHANNEL SEPARATION	60 (1 kHz) / 60 (40 Hz) / 50 (10 kHz) dB
DAMPING FACTOR (8 ohms)	60 (1 kHz) / 60 (40 Hz) / 52 (12.5 kHz) dB
OUTPUT REQUIRED SPEAKER IMPEDANCE	A, B : 4 to 16 ohms A + B : 8 to 16 ohms
INPUT SENSITIVITY PHONO MM TUNER, AUX, TAPE 1, 2	2.5 mV/47 kohms 150 mV/100 kohms
OUTPUT LEVEL/IMPEDANCE TAPE REC 1, 2	150 mV
PHONO MAXIMUM INPUT LEVEL (1 kHz) MM	150 mV
FREQUENCY RESPONSE PHONO (RIAA Deviation) TUNER, AUX, TAPE 1, 2	±0.5 dB 5 Hz to 100 kHz (-3 dB)
TONE CONTROL BASS TREBLE	±8 dB (100 Hz) ±10 dB (10 kHz)
LOUDNESS CONTROL (Volume set at -30 dB Position)	+10 dB (100 Hz) +6 dB (10 kHz)
SUBSONIC FILTER	-3 dB/Oct at 18 Hz
POWER REQUIREMENTS	120V, 60 Hz for USA and Canada 220V, 50 Hz for Europe except UK 240V, 50 Hz for UK and Australia 110V/220V/240V, 50/60 Hz switchable for other countries.
POWER CONSUMPTION	U ... 200W E, V ... 275W B, S ... 300W
DIMENSIONS	440 (W) × 100 (H) × 312 (D) mm (17.3 × 3.9 × 12.3 inches)
WEIGHT	6.1 kg (13.4 lbs)

* For improvement purposes, specifications and design are subject to change without notice.

II. DISMANTLING OF UNIT

In case of trouble, etc. necessitating dismantling, please dismantle in the order shown in the photographs. Reassemble in reverse order.

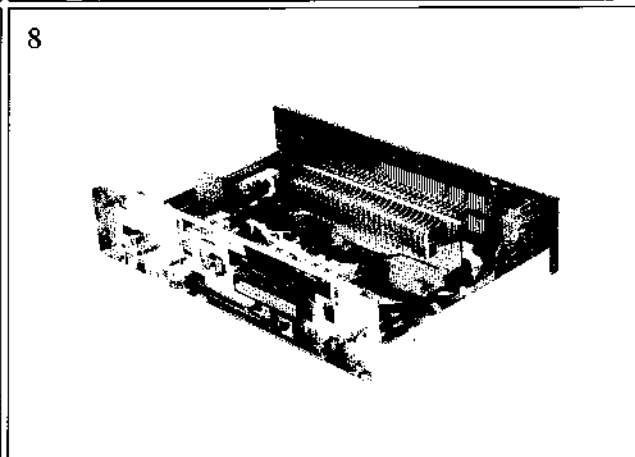
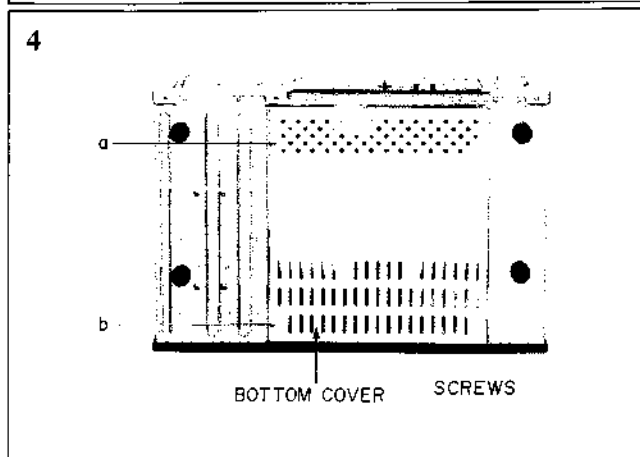
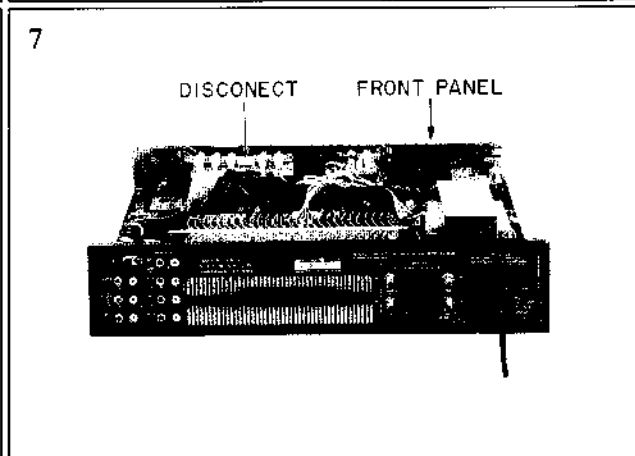
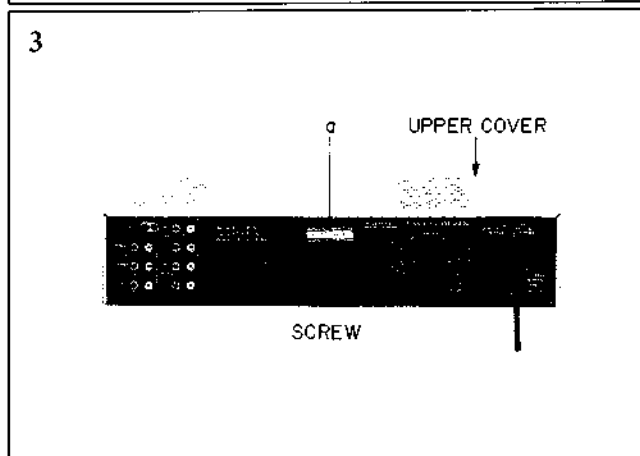
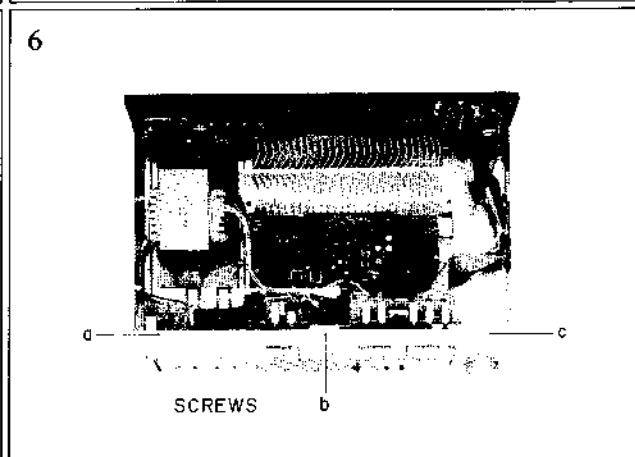
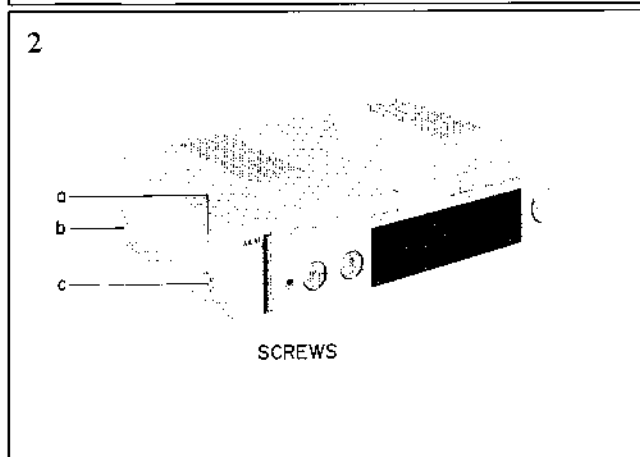
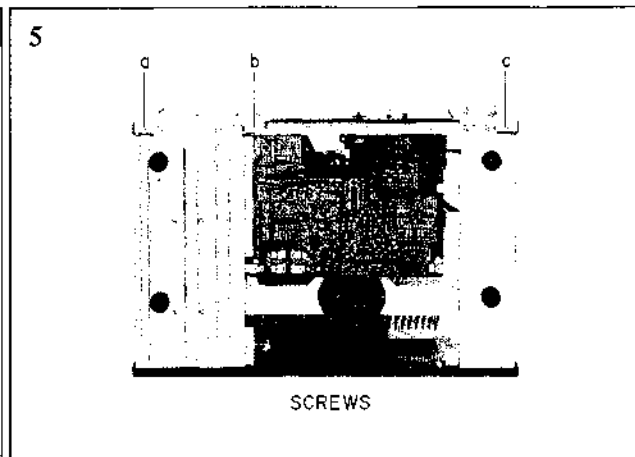
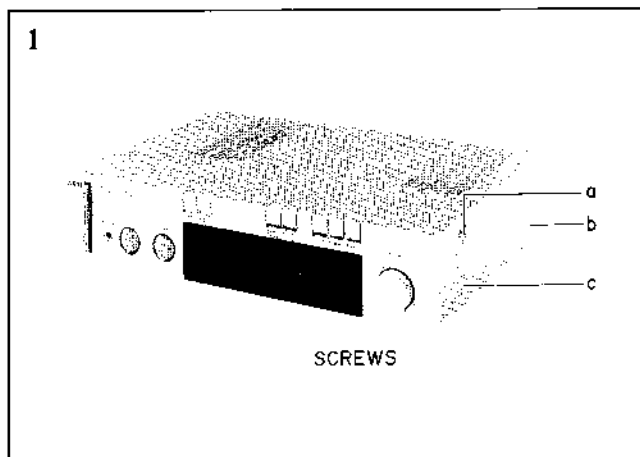

III. CONTROLS

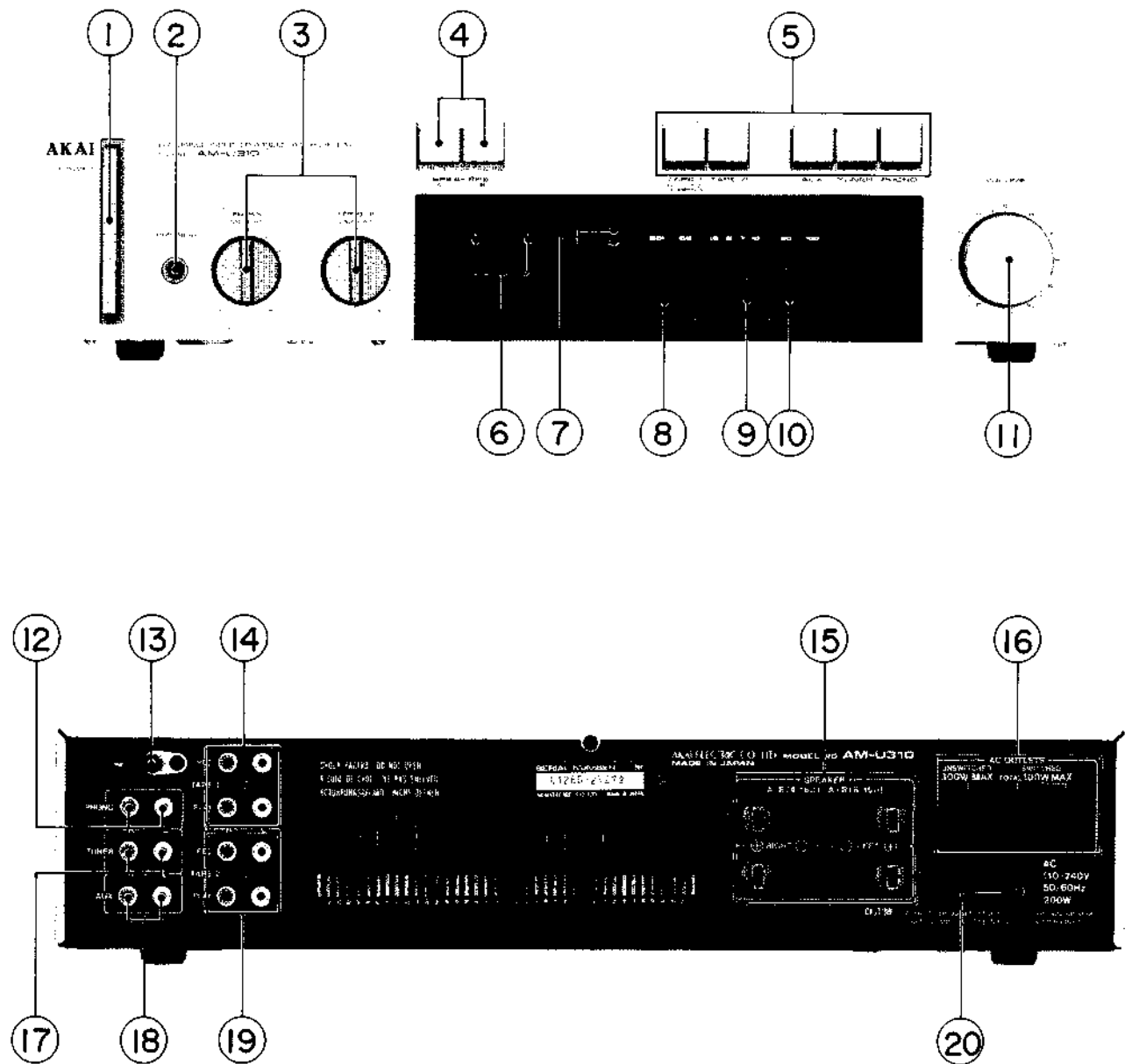

Fig. 1 Controls

- | | |
|--|---|
| <ol style="list-style-type: none"> 1. POWER SWITCH 2. HEADPHONE JACK (PHONES) 3. TONE CONTROLS 4. SPEAKERS SWITCHES 5. INPUT SELECTOR SWITCHES with INDICATORS 6. SPEAKERS A and B INDICATORS 7. FLD POWER INDICATOR (LEFT/RIGHT) 8. STEREO BALANCE CONTROL 9. SUBSONIC SWITCH 10. LOUDNESS SWITCH | <ol style="list-style-type: none"> 11. VOLUME CONTROL 12. PHONO JACKS 13. GROUND TERMINAL (///) 14. TAPE 1 REC/PLAY JACKS 15. A and B SPEAKER SYSTEM TERMINALS 16. AC OUTLETS (Some models are not equipped with this facility.) 17. TUNER JACKS 18. AUX JACKS 19. TAPE 2 REC/PLAY JACKS 20. POWER CORD |
|--|---|

IV. PRINCIPAL PARTS LOCATION

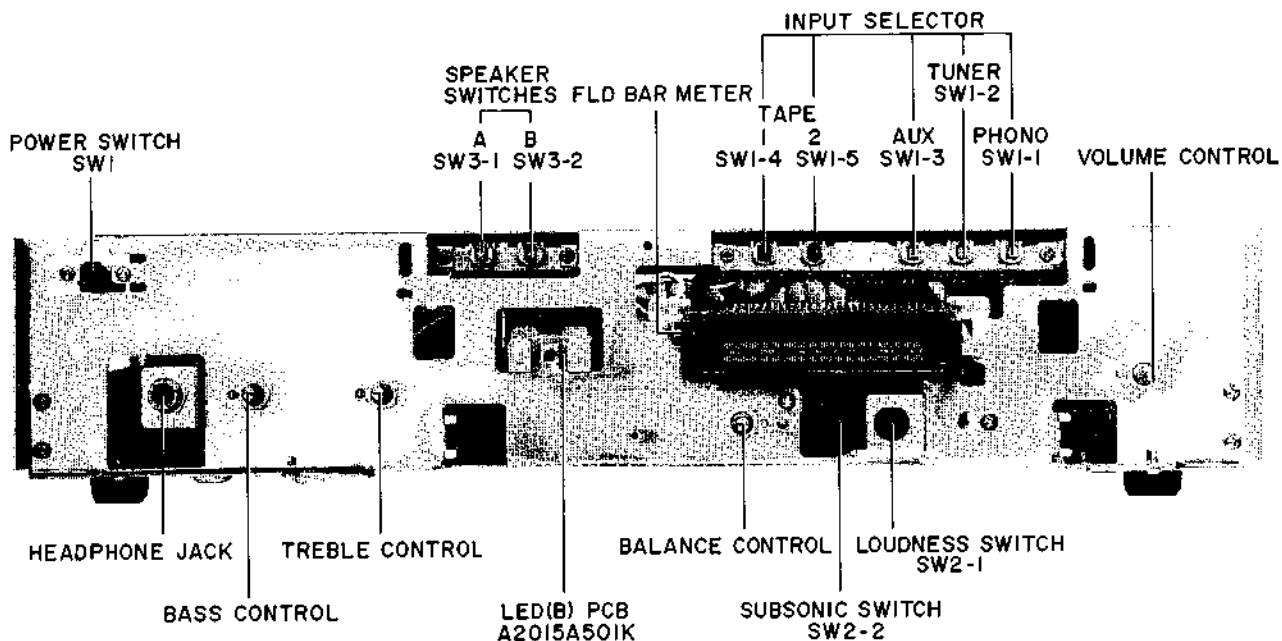

Fig. 2 Front View

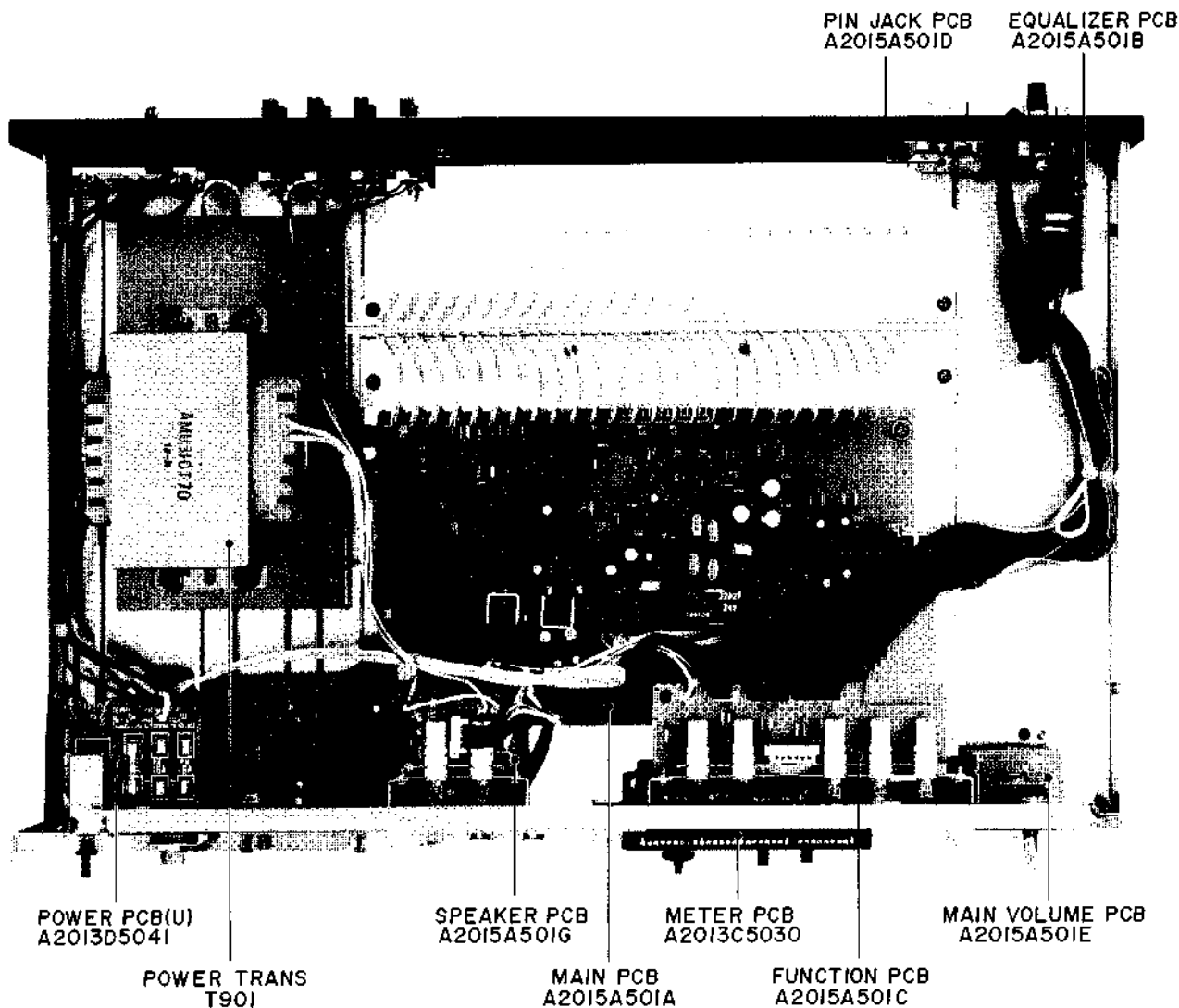

Fig. 3 Top View

V. VOLTAGE CONVERSION

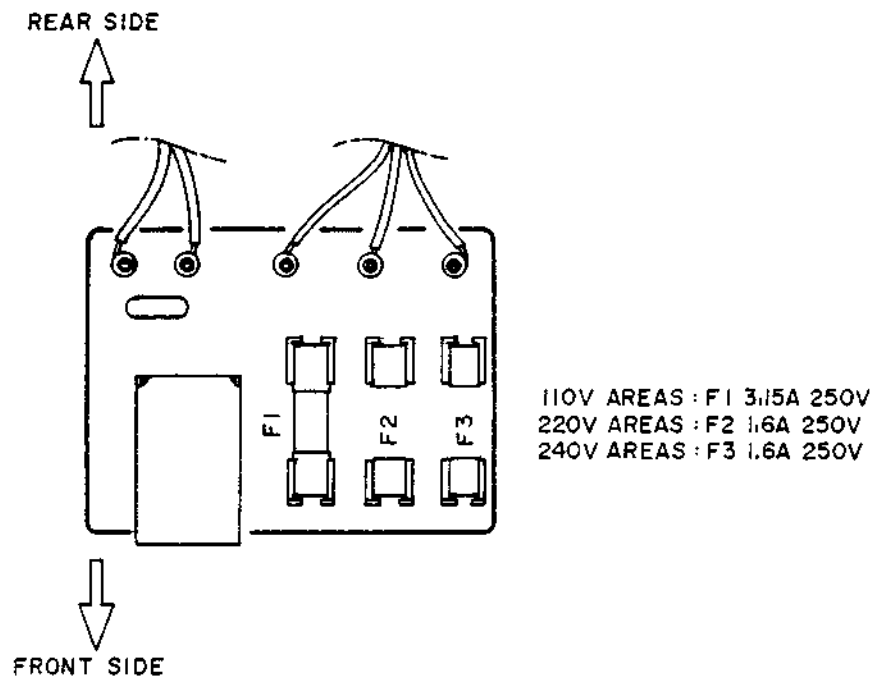

Fig. 4 Voltage Conversion (U Model)

Models for Canada, USA, Europe, UK and Australia are not equipped with this facility.

Each machine is preset at the factory according to destination but some machines can be set to 110–120V, 220V or 240V as required.

If voltage change is necessary, this can be accomplished as follows.

- 1) Disconnect AC Power Cord.
- 2) Loosen holding screws and remove upper case.
- 3) Remove existing line voltage fuse in proper fuse holder, explicitly following instructions printed on the rear panel.

VI. ADJUSTMENT

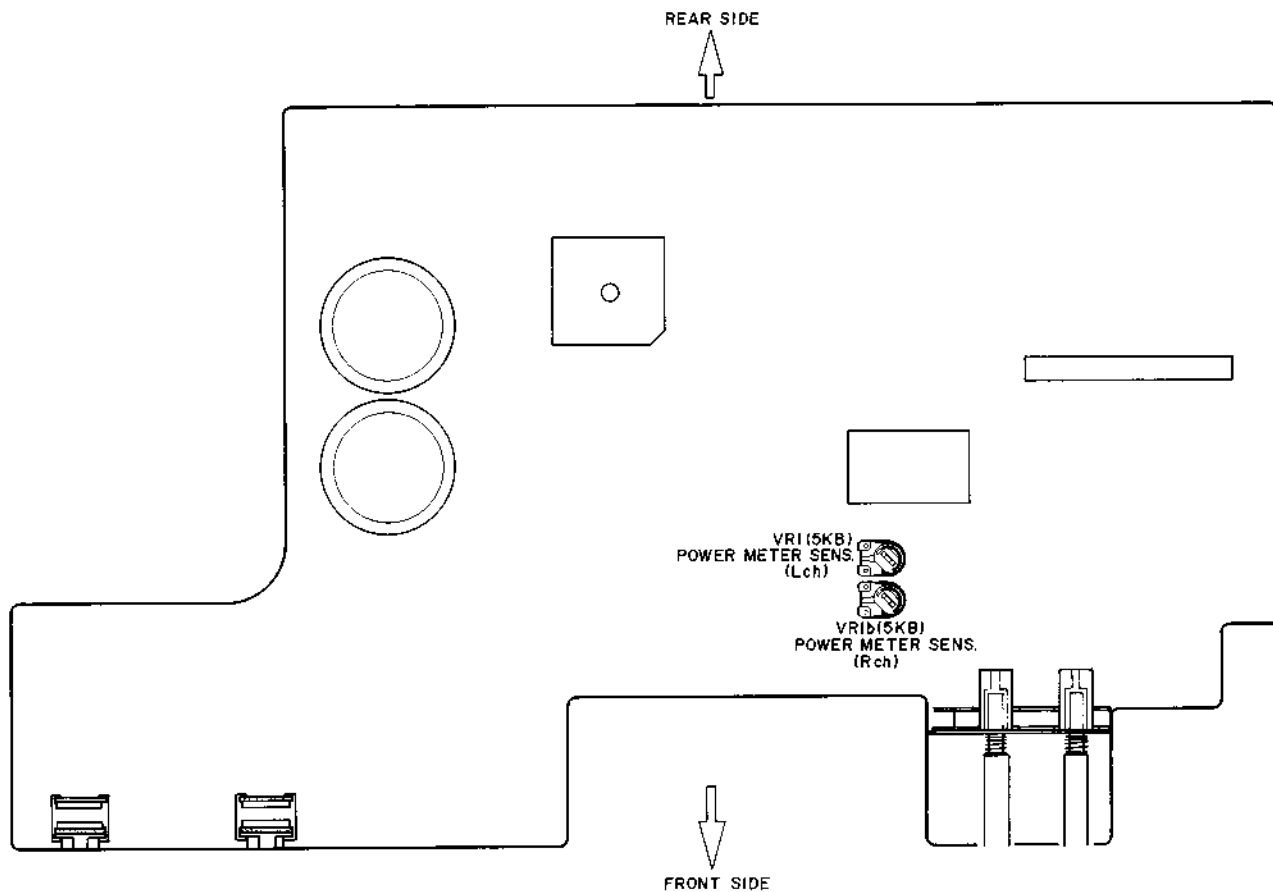

Fig. 5 Main P.C Board

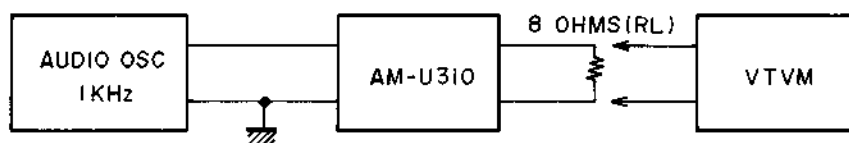

Fig. 6 Instrument Connection for Power Meter Sensitivity

I. POWER METER SENSITIVITY

ADJUSTMENT (Refer to Figs. 5, 6)

Connect the RL (8 ohms) resistors to Speaker Out. Then apply a 1 kHz signal to the AUX input terminals, adjusting the input level so as to obtain the rated output voltage level (15.5 V) at Speaker Out. Adjust VR1 (5 k Ω) on the Main P.C Board so that the 30 Watts Segment in the Power Meter lights up.

VII. CLASSIFICATION OF VARIOUS P.C BOARDS

1. P.C BOARD TITLES AND IDENTIFICATION NUMBERS

P.C Board Title	P.C Board Number	Remarks
Main P.C Board	A2015A501A	
Equalizer P.C Board	A2015A501B	
Function P.C Board	A2015A501C	
Pin Jack P.C Board	A2015A501D	
Main Volume P.C Board	A2015A501E	
Balance P.C Board	A2015A501F	
Speaker P.C Board	A2015A501G	
Head Phone P.C Board	A2015A501H	
LED (A) P.C Board	A2015A501J	
LED (B) P.C Board	A2015A501K	
Speaker Terminal P.C Board	A2015D5020	V
Meter P.C Board	A2013C5030	
Power P.C Board	A2013D5041	U
Power P.C Board	A2013D5050	A
Power P.C Board	A2013D5060	C, B, S
Power P.C Board	A2013D5071	E, V

2. COMPOSITION OF VARIOUS P.C BOARDS

1) MAIN P.C BOARD A2015A501A (2ED), MAIN VOLUME P.C BOARD A2015A501E, BALANCE P.C BOARD A2015A501F HEAD PHONE P.C BOARD A2015A501H

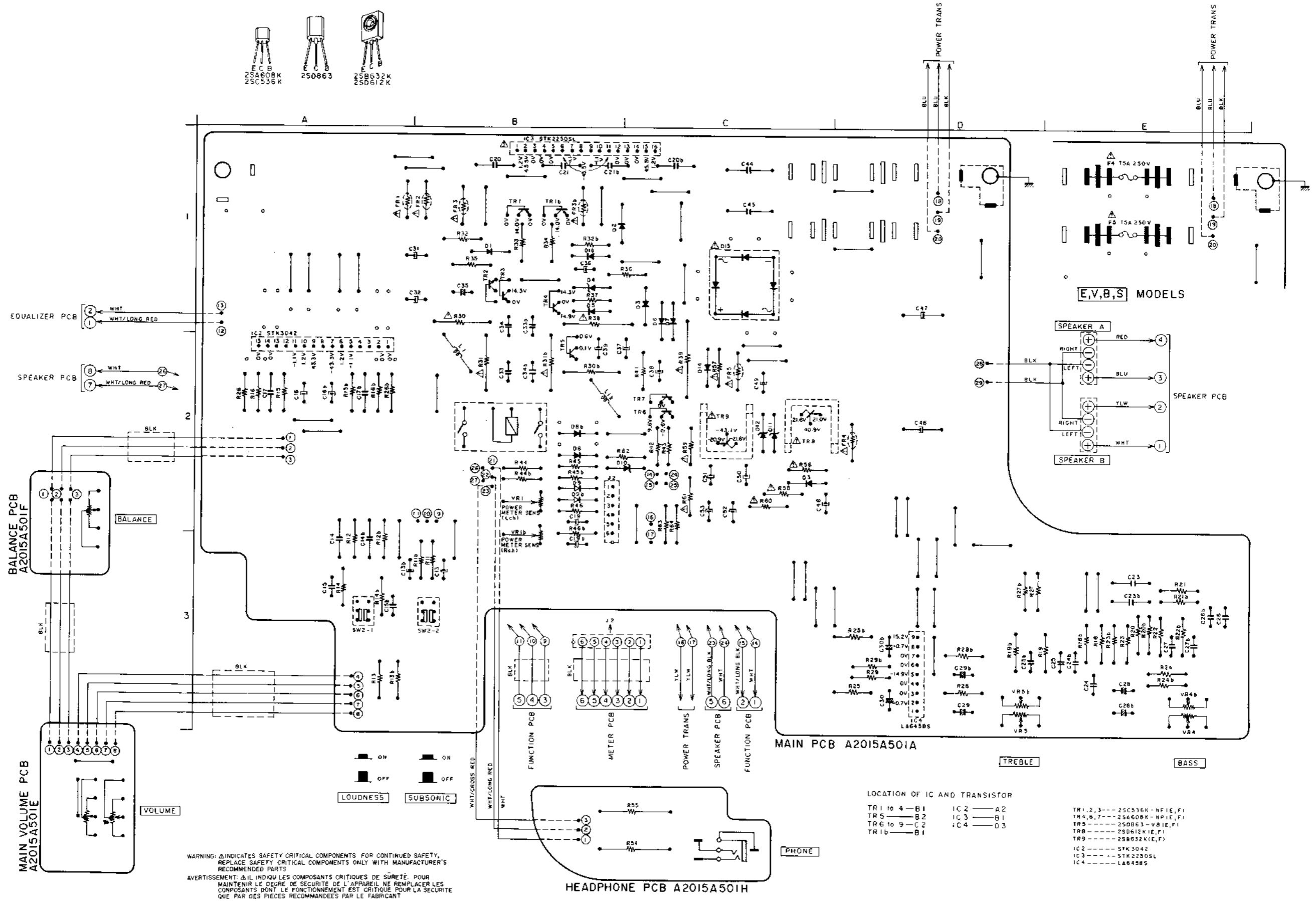

2) EQUALIZER P.C BOARD A2015A501B

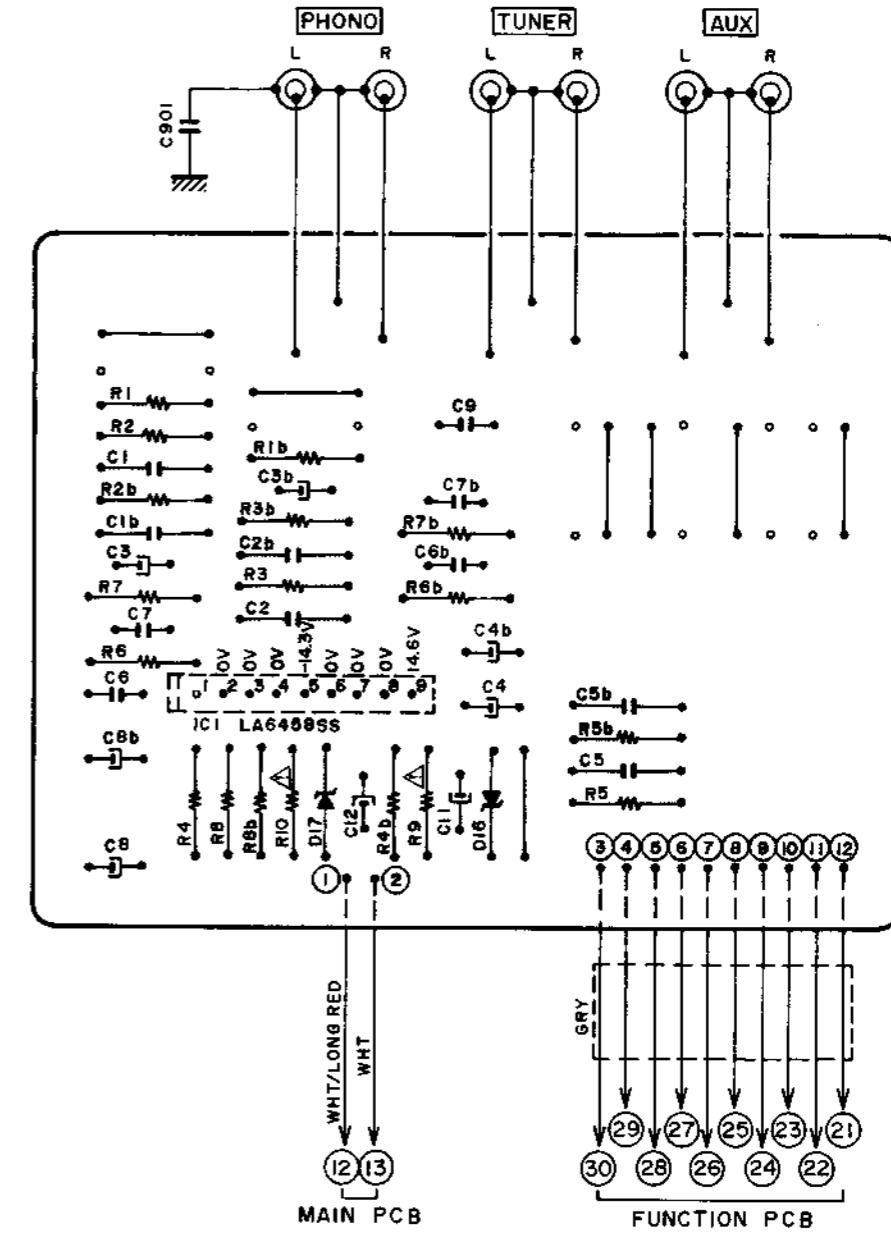
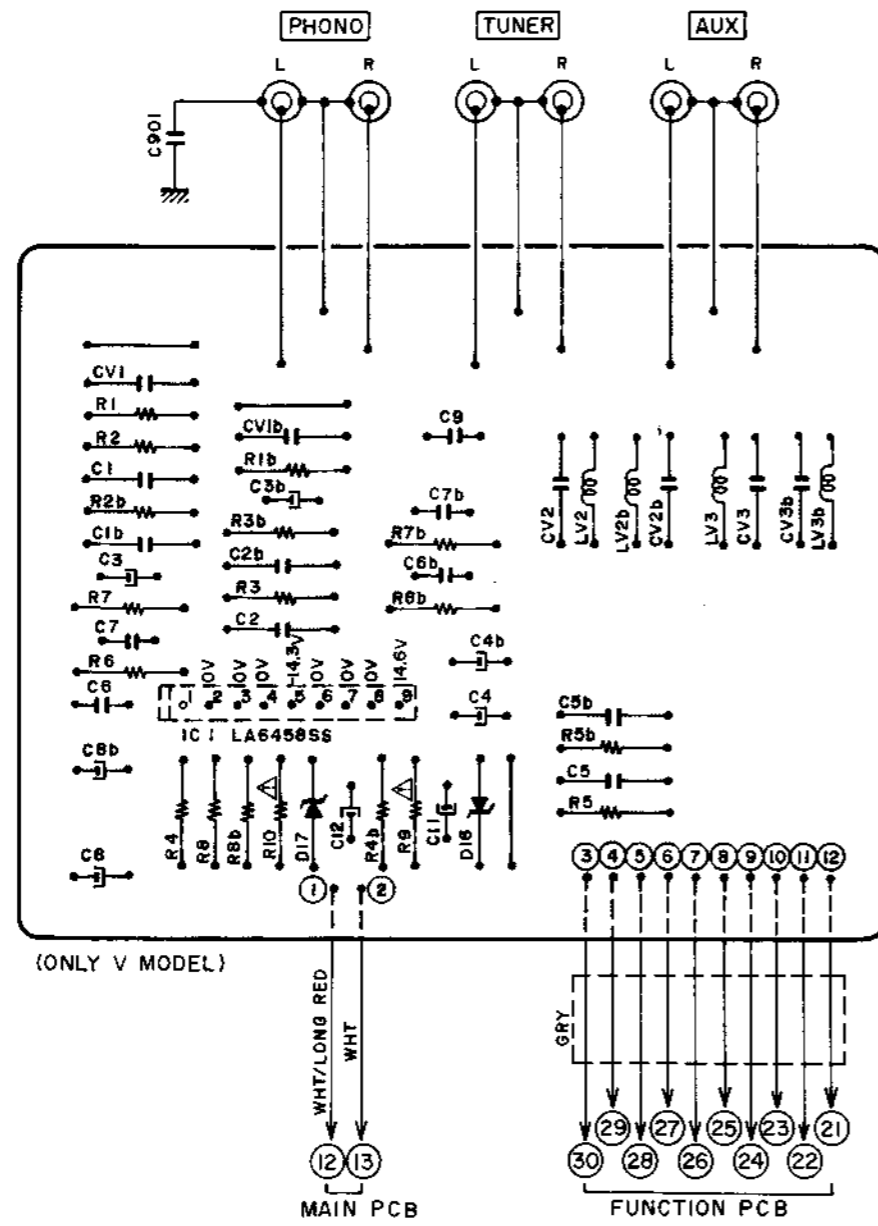

WARNING: Δ INDICATES SAFETY CRITICAL COMPONENTS. FOR CONTINUED SAFETY, REPLACE SAFETY CRITICAL COMPONENTS ONLY WITH MANUFACTURER'S RECOMMENDED PARTS.

AVERTISSEMENT: Δ IL INDIQUE LES COMPOSANTS CRITIQUES DE SÛRETÉ. POUR MAINTENIR LE DEGRÉ DE SÛRETÉ DE L'APPAREIL, NE REMPLACEZ LES COMPOSANTS DONT LE FONCTIONNEMENT EST CRITIQUE POUR LA SÛRETÉ QUE PAR DES PIÈCES RECOMMANDÉES PAR LE FABRICANT.

3) FUNCTION P.C BOARD A2015A501C, LED (A) P.C BOARD A2015A501J

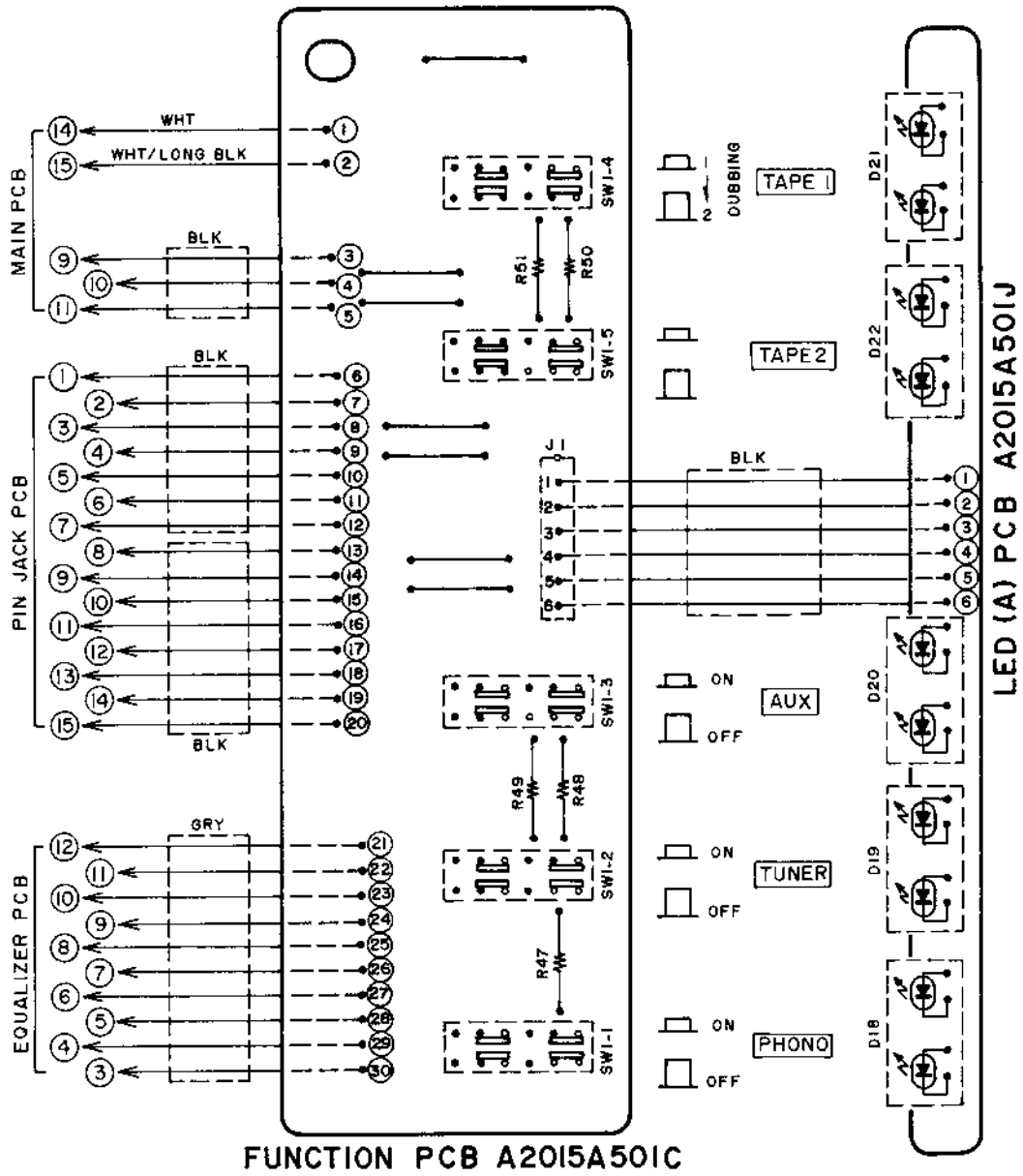

4) PIN JACK P.C BOARD A2015A501D

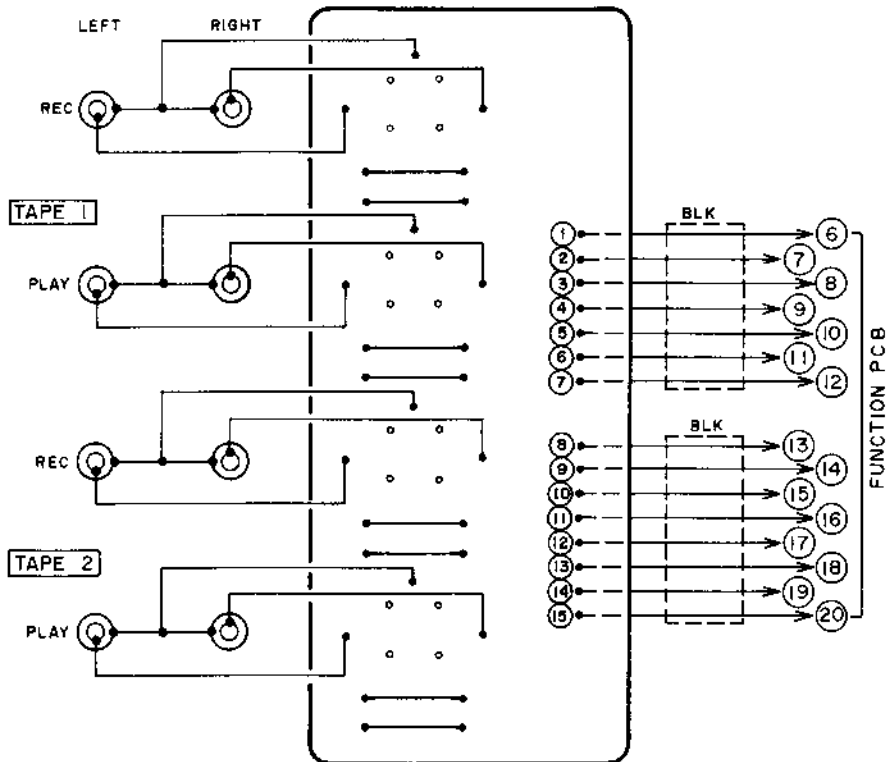
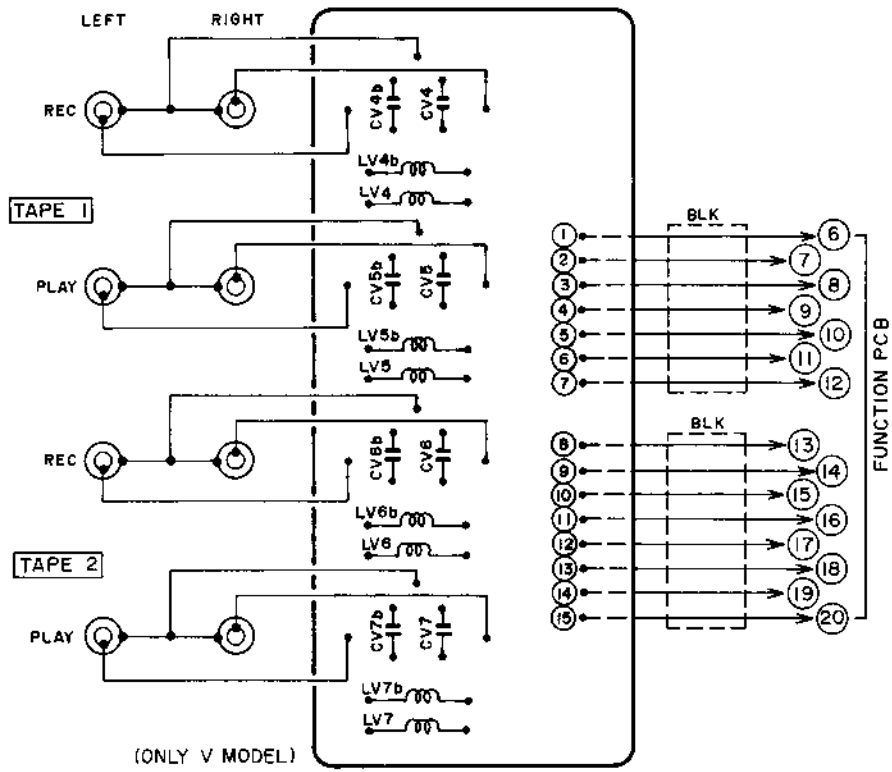

5) SPEAKER P.C BOARD A2015A501G, LED (B) P.C BOARD A2015A501K

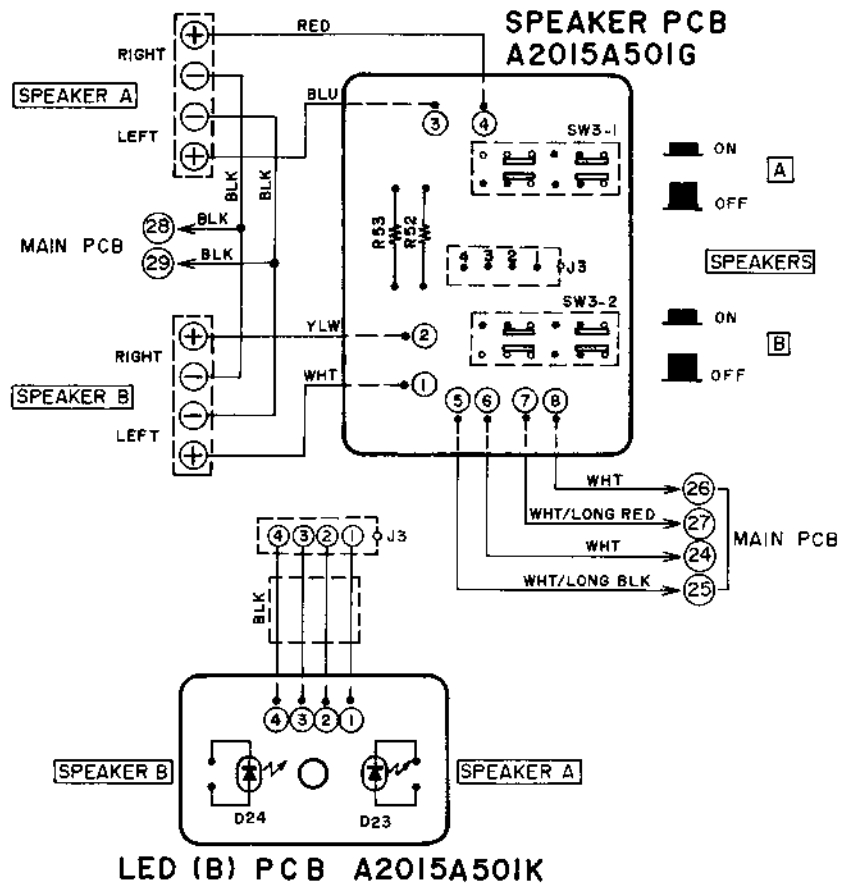

6) SPEAKER TERMINAL P.C BOARD A2015D5020 (V)

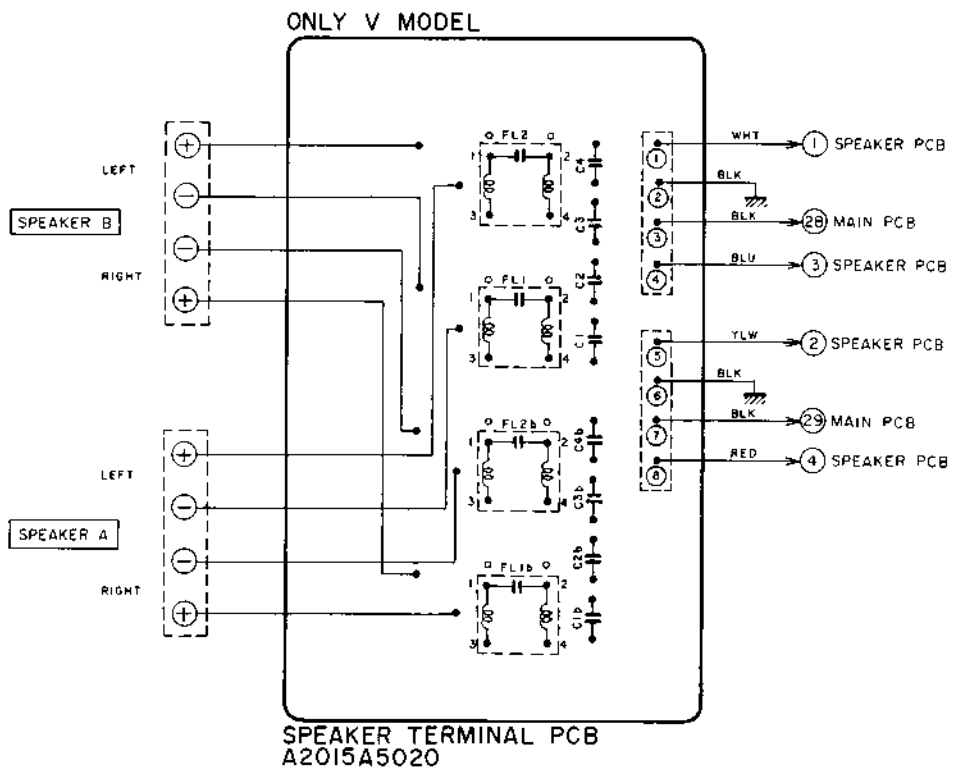

7) METER P.C BOARD A2013C5030

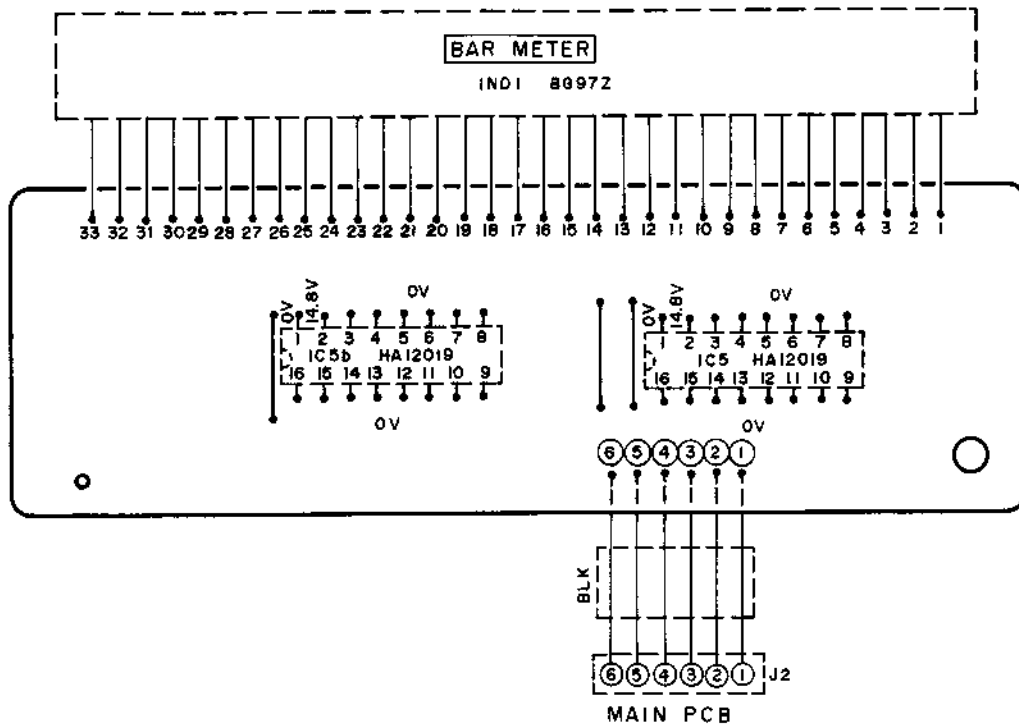

8) POWER P.C BOARD A2013D5041 (U)

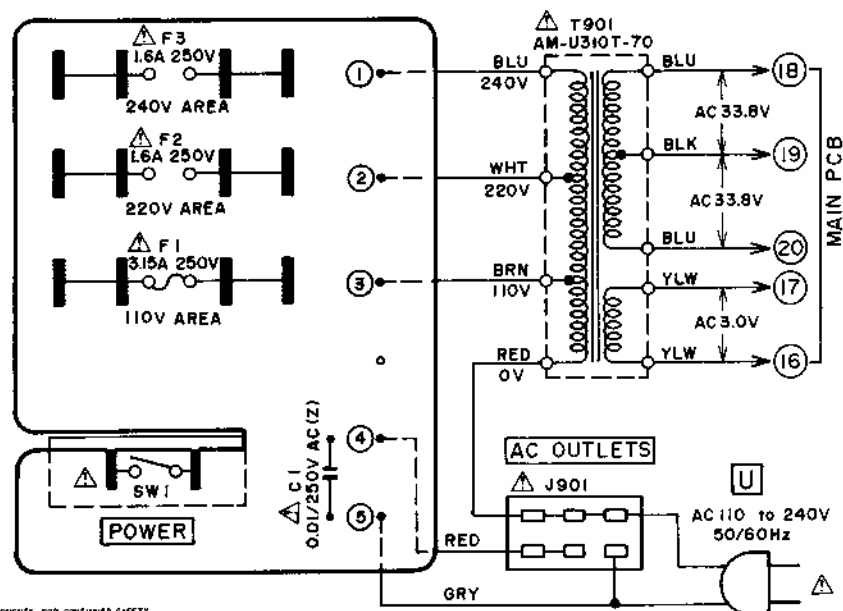

WARNING: Δ INDICATES SAFETY CRITICAL COMPONENTS. FOR CONTINUED SAFETY, REPLACE SAFETY CRITICAL COMPONENTS ONLY WITH MANUFACTURER'S RECOMMENDED PARTS.
 AVERTISSEMENT: Δ IL INDIQUE LES COMPOSANTS CRITIQUES DE SÛRETÉ. POUR MAINTENIR LE DEGRÉ DE SÛRETÉ DE L'APPAREIL, NE REMPLACEZ LES COMPOSANTS DONT LE FONCTIONNEMENT EST CRITIQUE POUR LA SÛRETÉ QUE PAR DES PIÈCES RECOMMANDÉES PAR LE FABRICANT.

9) POWER P.C BOARD A2013D5050 (A), A2013D5060 (C)

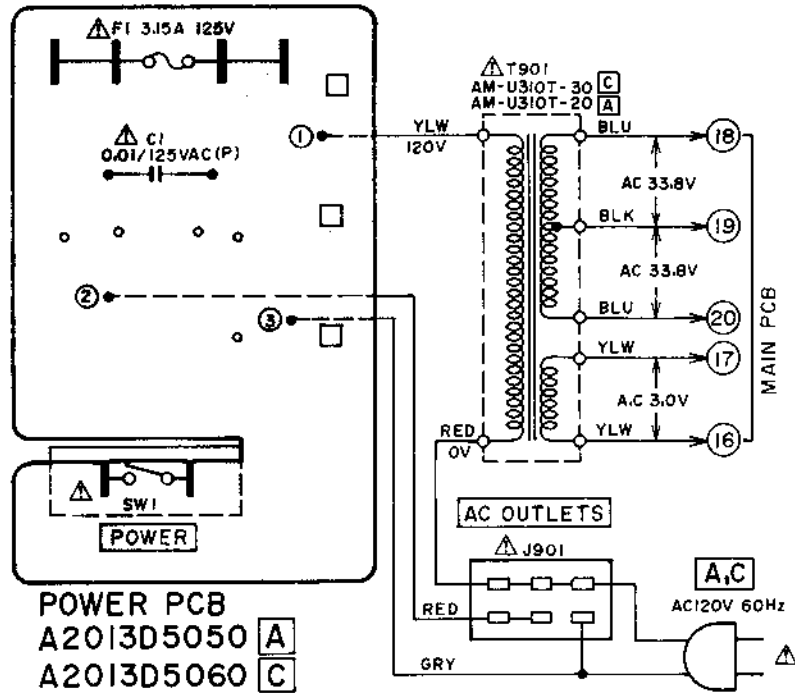

10) POWER P.C BOARD A2013D5060 (B, S), A2013D5071 (E, V)

WARNING: INDICATES SAFETY CRITICAL COMPONENTS. FOR CONTINUED SAFETY, REPLACE SAFETY CRITICAL COMPONENTS ONLY WITH MANUFACTURER'S RECOMMENDED PARTS.
AVERTISSEMENT: IL INDIQUE LES COMPOSANTS CRITIQUES DE SÛRETÉ. POUR MAINTENIR LE DEGRÉ DE SÛRETÉ DE L'APPAREIL, NE REMPLACEZ LES COMPOSANTS DONT LE FONCTIONNEMENT EST CRITIQUE POUR LA SÛRETÉ QUE PAR DES PIÈCES RECOMMANDÉES PAR LE FABRICANT.

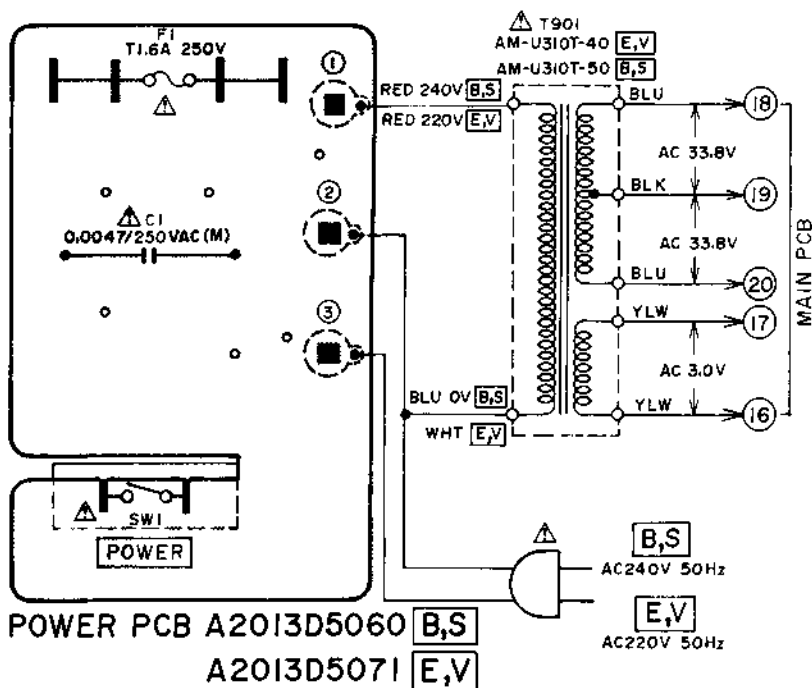

MEMO

SECTION 3

PARTS LIST

TABLE OF CONTENTS

1. RECOMMENDED SPARE PARTS	21
2. MAIN P.C BOARD BLOCK	21
3. POWER P.C BOARD BLOCK	22
4. METER P.C BOARD BLOCK	22
5. SPEAKER TERMINAL P.C BOARD BLOCK	22
6. ASSEMBLY BLOCK	22
7. FINAL ASSEMBLY BLOCK	24
INDEX	25

Resistor and Capacitor which is not listed in this parts list, please refer to COMMON LIST FOR SERVICE PARTS.

HOW TO USE THIS PARTS LIST

1. This parts list is compiled by various individual blocks based on assembly process.
2. When ordering parts, please describe parts number, serial number, and model number in detail.
3. How to read List

--- The reference number corresponds with illustration or photo number of that particular parts list.

--- This number corresponds with the Figure Number.
 --- This number corresponds with the individual parts index number in that figure.

12-115x A small "x" indicates the inability to show that particular part in the Photo or Illustration.

Ref. No.	Parts No.	Description
FLYWHEEL BLOCK #13		
12-115x	800425	Flywheel Block Assy. Comp.
12-116	244506	Flywheel Only
12-117x	244754	Felt, Flywheel
12-118	251324	Main Metal Case
12-119	253080	Main Metal

4. The symbol numbers shown on the P.C. Board list can be matched with the Composite Views of Components of the Schematic Diagram or Service Manual.
5. Please utilize separate "Common List for Service Parts" for Resistor Parts orders.
6. The shape of the parts and parts name, etc. can be confirmed by comparing them with the parts shown on the Electrical Parts Table of P.C. Board.
7. Both the kind of part and installation position can be determined by the Parts Number. To determine where a parts number is listed, utilize Parts Index at end of Parts List.
 It is necessary first of all to find the Parts Number. This can be accomplished by using the Reference Number listed at right of parts number in the Parts Index. (meaning of ref. no. outlined in Item 3 above).
8. Utilize separate "Price List for Parts" to determine unit price. The most simple method of finding parts Price is to utilize the reference number.

CAUTION:

1. When placing an order for parts, be sure to list the parts no., model no., and description. There are instances in which if any of this information is omitted, parts cannot be shipped or the wrong parts will be delivered.
2. Please be careful not to make a mistake in the parts no. If the parts no. is in error, a part different from the one ordered may be delivered.
3. Because parts number and parts unit supply in the Preliminary Service Manual (Basic Parts List) may be partially changed, please use this parts list for all future reference.

WARNING: **⚠** INDICATES SAFETY CRITICAL COMPONENTS. FOR CONTINUED SAFETY, REPLACE SAFETY CRITICAL COMPONENTS ONLY WITH MANUFACTURER'S RECOMMENDED PARTS.

AVERTISSEMENT: **⚠** IL INDIQU LES COMPOSANTS CRITIQUES DE SURETE. POUR MAINTENIR LE DEGRE DE SECURITE DE L'APPAREIL NE REMPLACER LES COMPOSANTS DONT LE FONCTIONNEMENT EST CRITIQUE POUR LA SECURITE QUE PAR DES PIECES RECOMMANDEES PAR LE FABRICANT.

1. RECOMMENDED SPARE PARTS

Because, if the parts listed below are on hand, almost any repair can be accomplished, we suggest that you stock these Recommended Spare Parts Items.

REF. NO.	PARTS NO.	DESCRIPTION
1-1	BT-337165	△ TRANS POWER AM-U310T-20 (A)
1-2	BT-337166	△ TRANS POWER AM-U310T-30 (C)
1-3	BT-337167	△ TRANS POWER AM-U310T-40 (E,V)
1-4	BT-337168	△ TRANS POWER AM-U310T-50 (B,S)
1-5	BT-337169	△ TRANS POWER AM-U310T-70 (U)
1-6	ED-309341	D GERMA H 1K34A
1-7	ED-322773	D LED SLP-255D-01 GRN
1-8	ED-336786	D LED SLP-271D GRN
1-9	ED-200749	D SILICON DBA60-K15 400/6.0A
1-10	ED-337153	D SILICON H DS446FA5 F10
1-11	ED-301911	D SILICON H DS448
1-12	ED-330218	D ZENER H HZ15L 2
1-13	ED-332336	D ZENER H HZ20 3
1-14	ED-570510	D ZENER H WZ-058
1-15	ED-327042	D ZENER H WZ-140
1-16	EF-601964	△ FUSE SEMKO T 250V 1.60A (F1) (E,B,S,V)
1-17	EF-249851	△ FUSE SEMKO T 250V 5A (F4,5) (E,B,S,V)
1-18	EF-311839	△ FUSE TSC A 250V 1.6A (F1,2) (U)
1-19	EF-326639	△ FUSE TSC A 250V 3.15A (F3) (U)
1-20	EF-323080	△ FUSE TSC 125V 3.15A (F1) (C,A)
1-21	EI-315799	IC HA12019
1-22	EI-338390	IC LA6458S-AKA1
1-23	EI-336390	IC LA6458SS
1-24	EI-337154	IC STK-2250SL
1-25	EI-323563	IC STK-3042
1-26	EJ-240535	△ SOCKET OUTLET S-I6526 U 3x2P (U,A)
1-27	EJ-332248	△ SOCKET OUTLET S-I6527#01 3x2P (C)
1-28	EJ-332110	PHONE J 3P HLIJ0316-020 6.3 (P)
1-29	EJ-331614	PHONE J 3P HLIJ0316-23 6.3
1-30	EJ-338035	TERMINAL PUSH ANB-016-ABA P 8P (V)
1-31	EJ-337163	TERMINAL W/SCREW ANB-018-ABA S 8P (EXCEPT V)
1-32	EM-336916	IND FL BG97Z GRAPH
1-33	EP-337159	RELAY SIG G4Z-2282P 2NO 24V
1-34	ER-341493	△ R FUSE ERD2FC F10 1/4W 1001G
1-35	ER-328519	△ R FUSE ERD2FC F10 1/4W 68R0G
1-36	ER-328520	△ R FUSE ERD2FC 1/4W 1000G
1-37	ES-328788	△ SW PUSH ESB-90144T 01-1 UC (C,A)
1-38	ES-336909	△ SW PUSH ESB-90259S 01-1 C (U,E,V,B,S)
1-39	ES-337156	SW PUSH ESB-62605 5-THROW
1-40	ES-337158	SW PUSH ESB-62606 2-THROW
1-41	ES-337157	SW PUSH ESB-62607 2-THROW
1-42	ET-323529	TR 2SA608K-NP E,F
1-43	ET-322598	TR 2SB632K E,F
1-44	ET-316171	TR 2SC536K-NP E,F
1-45	ET-310148	TR 2SD612K E,F
1-46	ET-328440	TR 2SD863-V8 E,F
1-47	FV-315540	R S-FIX H D8 3P 502
1-48	EV-336911	VR ROTARY 16P10x1J SPECIAL W105
1-49	EV-336898	VR ROTARY 16P20x2L C104
1-50	EV-336899	VR ROTARY 16P20x2M C104
1-51	EV-336912	VR ROTARY 16P20x2N B254

2. MAIN P.C BOARD BLOCK

REF. NO.	PARTS NO.	DESCRIPTION
2-1	BA-A2015A100A	PC MAIN BLK AM-U310(U)(U,C,A)
2-2	BA-A2015A100B	PC MAIN BLK AM-U310(E)(E,B,S)
2-3	BA-A2015A100C	PC MAIN BLK AM-U310(V)
2-4	BA-A2015A100D	PC MAIN BLK AM-U310-P(U) (U,C,A)
2-5	BA-A2015A100E	PC MAIN BLK AM-U310-P(E) (E,B,S)
2-6	BA-A2015A100F	PC MAIN BLK AM-U310-P(V)

MAIN P.C BOARD BLOCK

2-IC2	EI-323563	IC STK-3042
2-IC4	EI-338390	IC LA6458S-AKA1
2-TR1to3	ET-316171	TR 2SC536K-NP E,F
2-TR4	ET-323529	TR 2SA608K-NP E,F
2-TR5	ET-328440	TR 2SD863-V8 E,F
2-TR6,7	ET-323529	TR 2SA608K-NP E,F
2-TR8	ET-310148	△ TR 2SD612K E,F
2-TR9	ET-322598	△ TR 2SB632K E,F
2-D1to3	ED-301911	D SILICON H DS448
2-D4	ED-327042	D ZENER H WZ-140
2-D5	ED-301911	D SILICON H DS448
2-D6,7	ED-337153	D SILICON H DS446FA5 F10
2-D8	ED-301911	D SILICON H DS448
2-D9	ED-309341	D GERMA H 1K34A
2-D10	ED-570510	D ZENER H WZ-058
2-D11,12	ED-332336	D ZENER H HZ20 3
2-D13,14	ED-301911	D SILICON H DS448
2-D15	ED-200749	△ D SILICON DBA60-K15 400/6.0A
2-RL1	EP-337159	RELAY SIG G4Z-2282P 2NO 24V
2-SW2	ES-337158	SW PUSH ESB-62606 2-THROW
2-VR1	EV-315540	R S-FIX D8 3P 502
2-VR4	EV-336899	VR ROTARY 16P20x2M C104
2-VR5	EV-336898	VR ROTARY 16P20x2L C104
2-L1	EO-336902	COIL DET2 106AK-026 1.00μH
2-FR1,2	ER-328520	△ R FUSE ERD2FC 1/4W 1000G
2-FR3	ER-341493	R FUSE ERD2FC F10 1/4W 1001G
2-FR4,5	ER-328519	R FUSE ERD2FC F10 1/4W 68R0G
2-R30,31	ER-308875	△ R CB H SNP FS RDS 1/2W 100J
2-R38	ER-333067	△ R OMF H SNP FS 2W 821J
2-R39	ER-245564	△ R OMF H FS 2W 152J
2-R56,57	ER-325269	△ R CB H SNP FS RDS 1/4W 222J
2-R58,59	ER-322787	△ R CB H SNP FS RDS 1/4W 100J
2-R60,61	ER-316802	△ R CB H SNP FS RDS 1/4W 471J
2-C44,45	EC-320548	C CE V F 103Z 250AC
2-C46,47	EC-337162	C CE V SNP TUS 103M 50DC

EQUALIZER P.C BOARD BLOCK

2-IC1	EI-336930	IC LA6458SS
2-D16,17	ED-330218	D ZENER H HZ15L 2
2-LV2,3	EO-336934	COIL FIX LAL03KH 2.2μH M
2-R9,10	ER-324184	R CB H SNP FS RDS 1/4W 121J

FUNCTION P.C BOARD BLOCK

2-SW1	ES-337156	SW PUSH ESB-62605 5-THROW
-------	-----------	---------------------------

PIN JACK P.C BOARD BLOCK

2-J5,6	EJ-336915	PIN J C-810 P 4P
2-LV4to7	EO-336934	COIL FIX LAL03KH 2.2μH M (V)

MAIN VOLUME P.C BOARD BLOCK

2-VR2	EV-336912	VR ROTARY 16P20x2N B254
-------	-----------	-------------------------

BALANCE P.C BOARD BLOCK

2-VR3	EJ-336911	VR ROTARY 16P10x1J SPECIAL W105
-------	-----------	------------------------------------

SPEAKER P.C BOARD BLOCK

2-SW3	ES-337157	SW PUSH ESB-62607 2-THROW
-------	-----------	---------------------------

HEADPHONE P.C BOARD BLOCK

2-J7	EJ-331614	PHONE J 3P HLIJ0316-23 6.3
2-J7	EJ-332110	PHONE J 3P HLIJ0316-020 6.3 (P)
2-R54,55	ER-313699	R OMF H FS 2W 221J

3. POWER P.C BOARD BLOCK

REF. NO.	PARTS NO.	DESCRIPTION
3-SW1	ES-336909	△ SW PUSH ESB-90259S 01-1 C (U,E,V,B,S)
3-SW1	ES-328788	△ SW PUSH ESB-90144T 01-1 UC (C,A)
3-C1	EC-320548	△ C CE V F 103Z 250AC (U)
3-C1	EC-314688	△ C CE V FZ 103P 125AC (C,A)
3-C1	EC-330307	△ C MMY V ECQUF 472M 250AC (E,V,B,S)

4. METER P.C BOARD BLOCK

REF. NO.	PARTS NO.	DESCRIPTION
4-IC5	EI-315799	IC HA12019
4-IN1	EM-336916	IND FL BG97Z GRAPH

5. SPEAKER TERMINAL P.C BOARD BLOCK (V MODEL ONLY)

REF. NO.	PARTS NO.	DESCRIPTION
5-FL1,2	ER-337108	FILTER LC LP MCD-450
5-TM1	EJ-338035	TERMINAL PUSH ANB-016-ABA P 8P

6. ASSEMBLY BLOCK

REF. NO.	PARTS NO.	DESCRIPTION
LED (A) P.C BOARD BLOCK		
6-1x	ED-336786	D LED SLP-271D GRN (D18to22)
LED (B) P.C BOARD BLOCK		
6-2x	ED-322773	D LED SLP-255D-01 GRN (D23,24)
HEAT SINK BLOCK		
6-3x	EI-337154	△ IC STK-2250SL (IC3)
ASSEMBLY BLOCK		
6-4	SP-342317A	PANEL REAR AM-U310 (U)
6-5x	SP-342317B	PANEL REAR AM-U310 (C,A)
6-6x	SP-332610C	PANEL REAR AM-U310 (E,V)
6-7x	SP-332610D	PANEL REAR AM-U310 (B,S)
6-8	ZS-319460	T2BR30x06STL BZN PROJECTION
6-9	EJ-240535	△ SOCKET OUTLET S-I6526 U 3x2P (U,A) (J901)
6-10x	FJ-332248	△ SOCKET OUTLET S-I6527#01 3x2P (C) (J901)
6-11	EJ-337163	TERMINAL W/SCREW ANB-018-ABA S 8P
6-12	ZS-463353	T2BR30x08STL BNI
6-13	EJ-329610	TERMINAL W/SCREW UB-0067 L 1P (TM901)
6-14	ZS-447761	T2BR30x06STL BNI
6-15	EW-306428	△ AC CORD 2 CORES KP-205A, VFF J (U)
6-16x	FW-305691	△ AC CORD 2 CORES KP-8, SPT-1 UC (C,A)
6-17x	EW-313882	△ AC CORD 2 CORES KP-419C, LTCE-2F E (E,V)
6-18x	EW-336926	△ AC CORD GTBS-2F 24/0.20x2 B (B)
6-19x	EW-336924	△ AC CORD 2 CORES KP-560, LTSA-2F S (S)
6-20	SZ-631945	STRAIN RELIEF SR-4N-4 (U,C,A,E,S,V)
6-21x	EJ-692908	STRAIN RELIEF SR-5N-4 (B)
6-22	BT-337169	△ TRANS POWER AM-U310T-70 (U)
6-23x	BT-337166	△ TRANS POWER AM-U310T-30 (C)
6-24x	BT-337165	△ TRANS POWER AM-U310T-20 (A)
6-25x	BT-337167	△ TRANS POWER AM-U310T-40 (E,V)
6-26x	BT-337168	△ TRANS POWER AM-U310T-50 (B,S)
6-27	ZS-435273	BID40x10STL CMT
6-28	ZW-413267	N FRANGE 40STL CMT
6-29x	ZW698308	RV NYL30x055 BL
6-30	SA-332850	ROUND FOOT
6-31x	ZS-565942	T2PAN40x08STL CMT
6-32x	SP-332608	COVER BOTTOM
6-33x	ZS-498273	T2BR30x08STL CMT PW080
6-34	EF-311839	△ FUSE TSC A 250V 1.6A (F1,2) (U)
6-35x	EF-326639	△ FUSE TSC A 250V 3.15A (F3) (U)
6-36x	EF-323080	△ FUSE TSC 125V 3.15A (F1) (C,A)
6-37x	EF-601964	△ FUSE SEMKO T 250V 1.60A (F1) (E,B,S,V)
6-38x	EF-249851	△ FUSE SEMKO T 250V 5A (F4,5) (E,B,S,V)

ASSEMBLY BLOCK

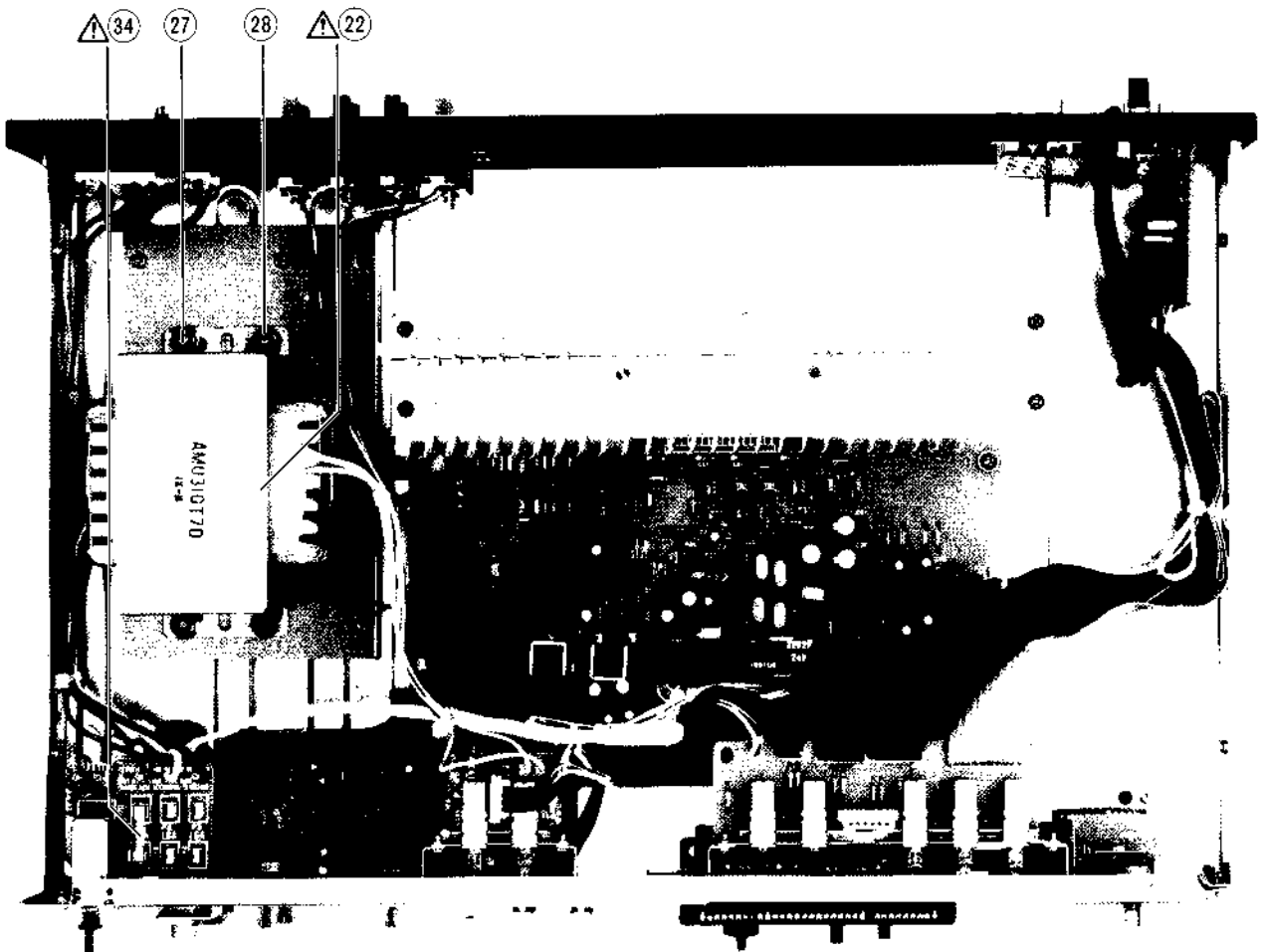
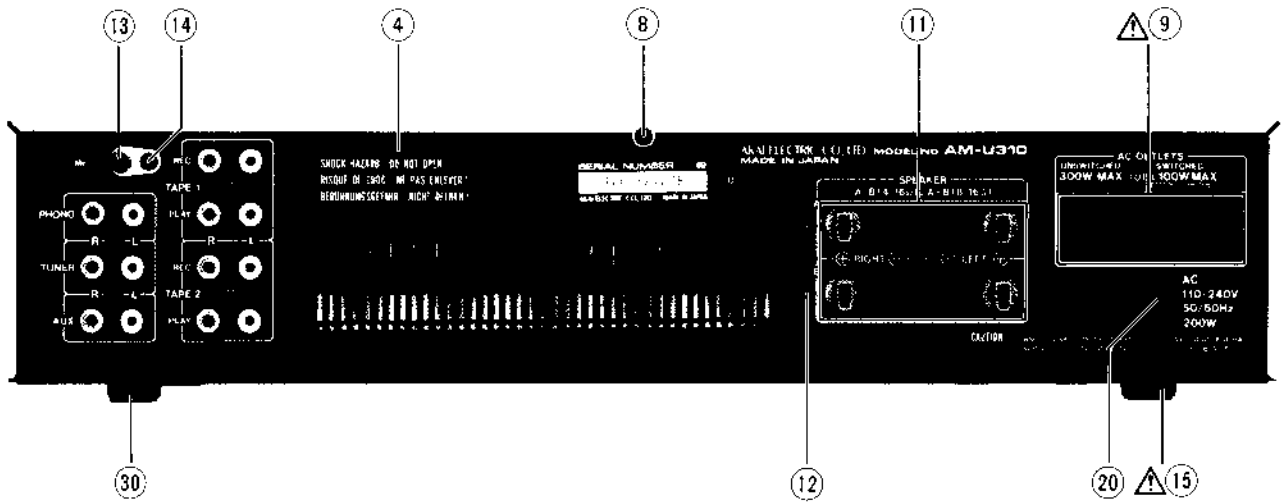

FINAL ASSEMBLY BLOCK

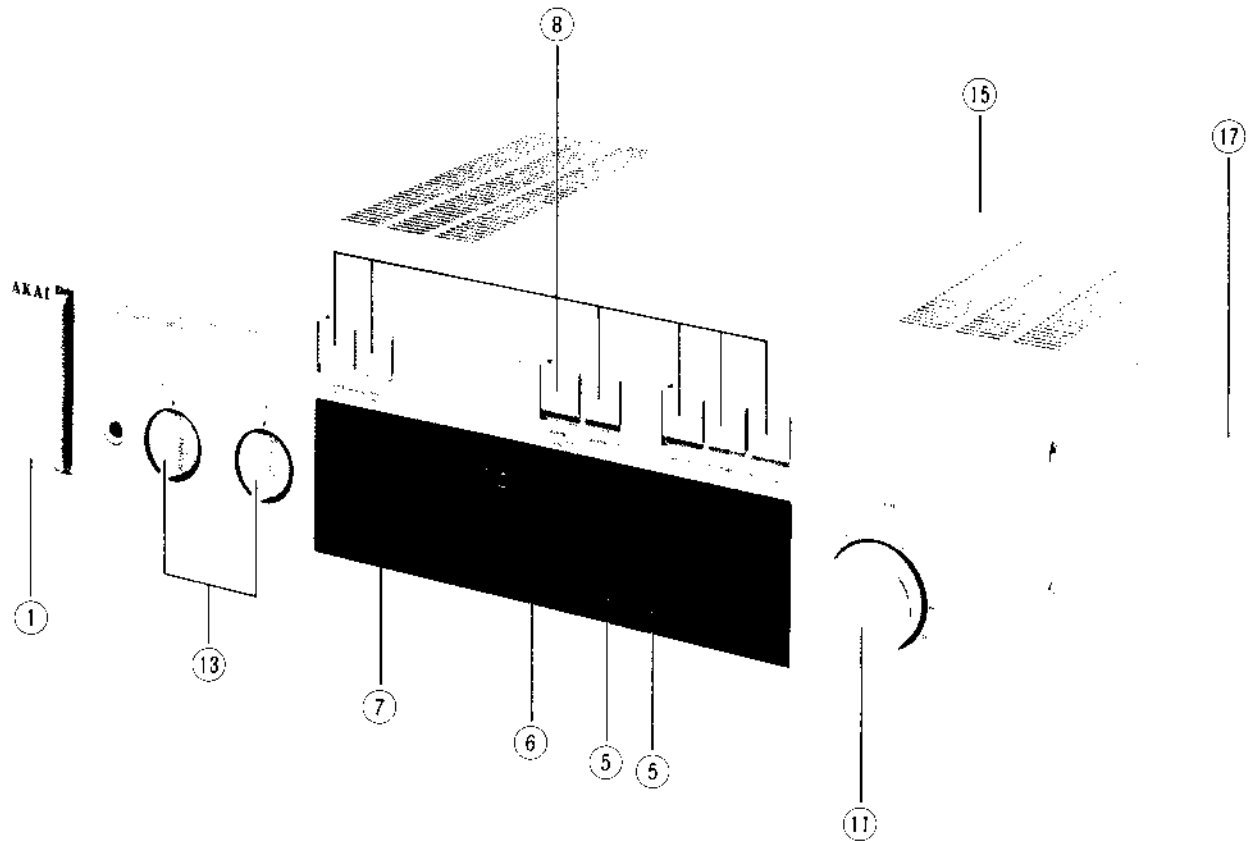

7. FINAL ASSEMBLY BLOCK

REF. NO.	PARTS NO.	DESCRIPTION
FRONT PANEL BLOCK		
7-1	BD-A2015A020A	PANEL FRONT BLK AM-U310
7-2x	BD-A2015A020B	PANEL FRONT BLK AM-U310-P
ESCUTCHEON BLOCK		
7-3x	SE-332531A	ESCUTCHEON KNOB SELECTOR
7-4x	SE-332531B	ESCUTCHEON KNOB SELECTOR-P
FINAL ASSEMBLY BLOCK		
7-5	SK-332536	KNOB PUSH (B)
7-6	SK-332534	KNOB ROTARY (C)
7-7	SE-B604426	WIND METER (B) PART
7-8	SK-332535A	KNOB PUSH (A)
7-9x	SK-332535B	KNOB PUSH (A)-P
7-10x	ZG-332538	SP PUSH KNOB (A)
7-11	SK-332532A	KNOB ROTARY (A)
7-12x	SK-332532B	KNOB ROTARY (A)-P
7-13	SK-332533A	KNOB ROTARY (B)
7-14x	SK-332533B	KNOB ROTARY (B)-P
7-15	SP-332609A	COVER UPPER
7-16x	SP-332609B	COVER UPPER-P
7-17	ZS-322570	ST BID40x08STL N13
7-18x	ZS-322580	ST BID40x08STL BN1

When ordering parts, please quote Parts Number, Description and Model Number.

INDEX

PARTS NO.	REF. NO.	PARTS NO.	REF. NO.	PARTS NO.	REF. NO.	PARTS NO.	REF. NO.
BA-A2015A100A	2-1	EV-336899	2-VR4				
BA-A2015A100B	2-2	EV-336911	2-VR3				
BA-A2015A100C	2-3	EV-336912	2-VR2				
BA-A2015A100D	2-4	EW-305691	6-16x				
BA-A2015A100E	2-5	FW-306428	6-15				
BA-A2015A100F	2-6	EW-313882	6-17x				
BD-A2015A020A	7-1	EW-336924	6-19x				
BD-A2015A020B	7-2x	EW-336926	6-18x				
BT-337165	6-24x	SA-332850	6-30				
BT-337166	6-23x	SE-B604426	7-7				
BT-337167	6-25x	SE-332531A	7-3x				
BT-337168	6-26x	SE-332531B	7-4x				
BT-337169	6-22	SK-332532A	7-11				
EC-314688	3-C1	SK-332532B	7-12x				
EC-320548	2-C44,45	SK-332533A	7-13				
EC-320548	3-C1	SK-332533B	7-14x				
EC-330307	3-C1	SK-332534	7-6				
EC-337162	2-C46,47	SK-332535A	7-8				
ED-200749	2-D15	SK-332535B	7-9x				
ED-301911	2-D5	SK-332536	7-5				
ED-301911	2-D8	SP-332608	6-32x				
ED-301911	2-D13,14	SP-332609A	7-15				
ED-301911	2-D11to3	SP-332609B	7-16x				
ED-309341	2-D9	SP-332610C	6-6x				
ED-322773	6-2x	SP-332610D	6-7x				
ED-327042	2-D4	SP-342317A	6-4				
ED-330218	2-D16,17	SP-342317B	6-5x				
ED-332336	2-D11,12	SZ-631945	6-20				
ED-336786	6-1x	ZG-332538	7-10x				
ED-337153	2-D6,7	ZS-319460	6-8				
ED-570510	2-D10	ZS-322570	7-17				
EF-249851	6-38x	ZS-322580	7-18x				
EF-311839	6-34x	ZS-435273	6-27				
EF-323080	6-36x	ZS-447761	6-14				
EF-326639	6-35x	ZS-463353	6-12				
EF-601964	6-37x	ZS-498273	6-33x				
EI-315799	4-IC5	ZS-565942	6-31x				
EI-323563	2-IC2	ZW-413267	6-28				
EI-336930	2-IC1	ZW-698308	6-29x				
EI-337154	6-3x						
EI-338390	2-IC4						
EJ-240535	6-9						
EJ-329610	6-13						
EJ-331614	2-J7						
EJ-332110	2-J7						
EJ-332248	6-10x						
EJ-336915	2-J5,6						
EJ-337163	6-11						
EJ-338035	5-TM1						
EJ-692908	6-21x						
EM-336916	4-IN1						
EO-336902	2-L1						
EO-336934	2-LV2,3						
EO-336934	2-LV4to7						
EP-337159	2-RL1						
ER-245564	2-R39						
ER-308875	2-R30,31						
ER-313699	2-R54,55						
ER-316802	2-R60,61						
ER-322787	2-R58,59						
ER-324184	2-R9,10						
ER-325269	2-R56,57						
ER-328519	2-FR4,5						
ER-328520	2-FR1,2						
ER-333067	2-R38						
ER-337108	5-FL1,2						
ER-341493	2-FR3						
ES-328788	3-SW1						
ES-336909	3-SW1						
ES-337156	2-SW1						
ES-337157	2-SW3						
ES-337158	2-SW2						
ET-310148	2-TR8						
ET-316171	2-TR1to3						
ET-322598	2-TR9						
ET-323529	2-TR4						
ET-323529	2-TR6,7						
ET-328440	2-TR5						
EV-315540	2-VR1						
EV-336898	2-VR5						

SECTION 3

SCHEMATIC DIAGRAM

1. SCHEMATIC DIAGRAM OF ICs
2. AM-U310 NO. 1640406A SCHEMATIC DIAGRAM

HA12019

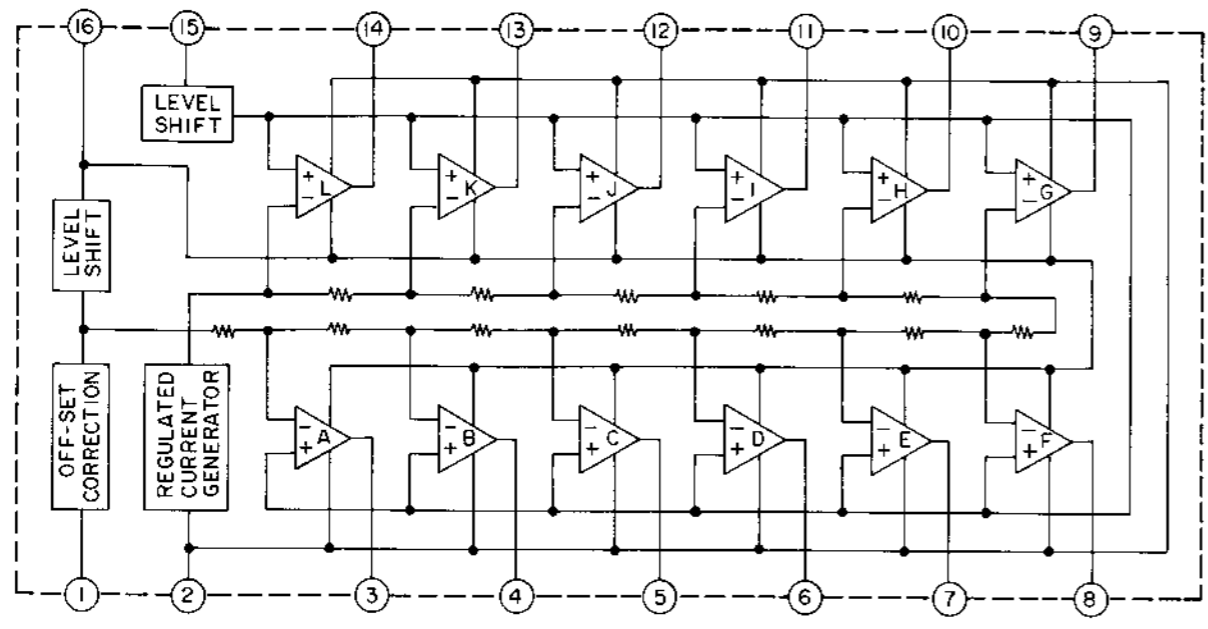

STK2250SL

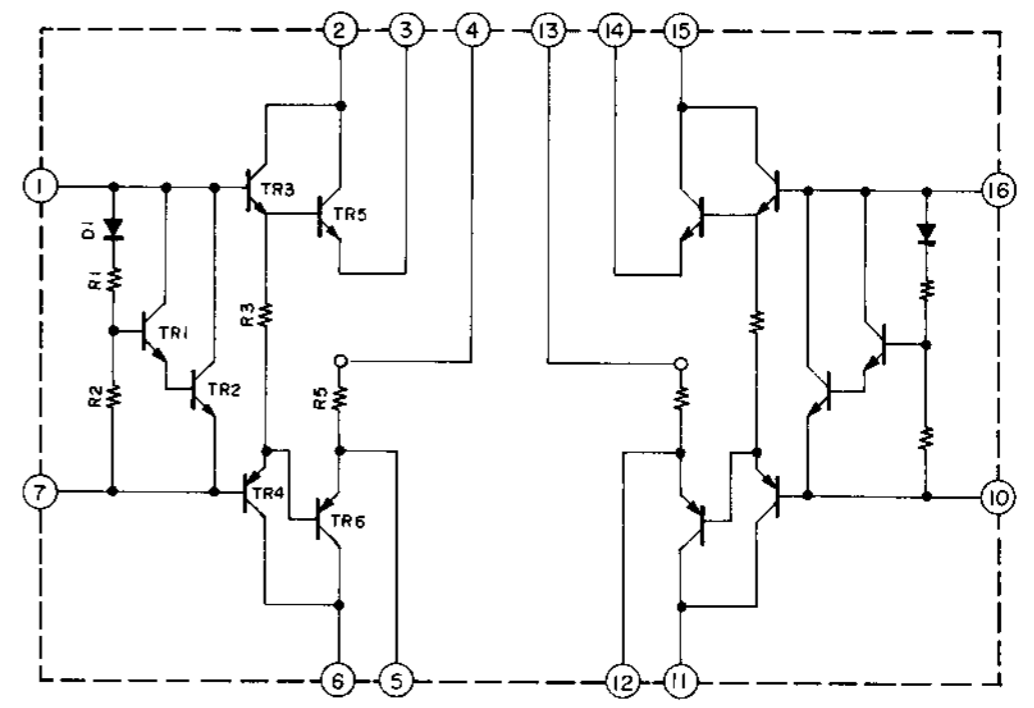

LA6458S

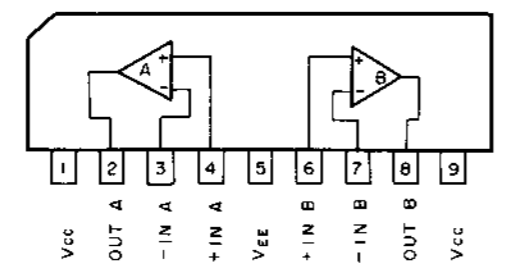

STK3042

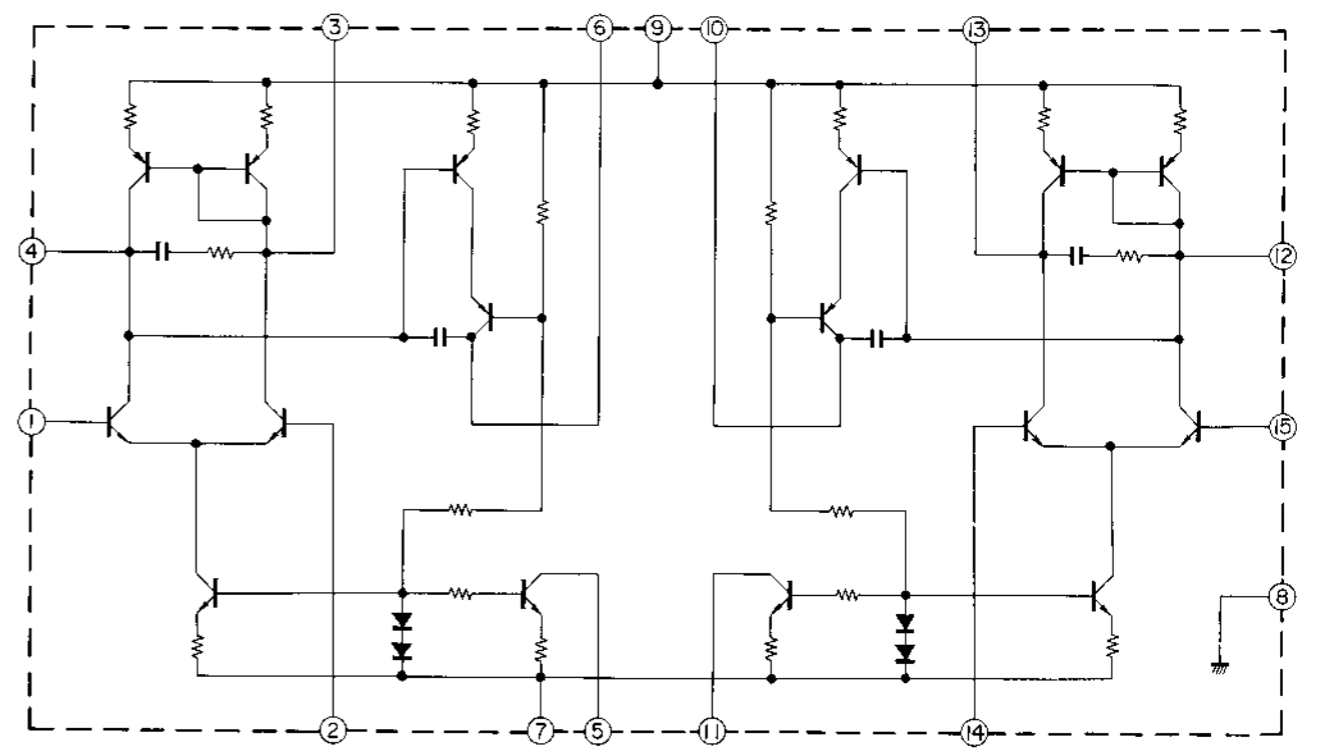

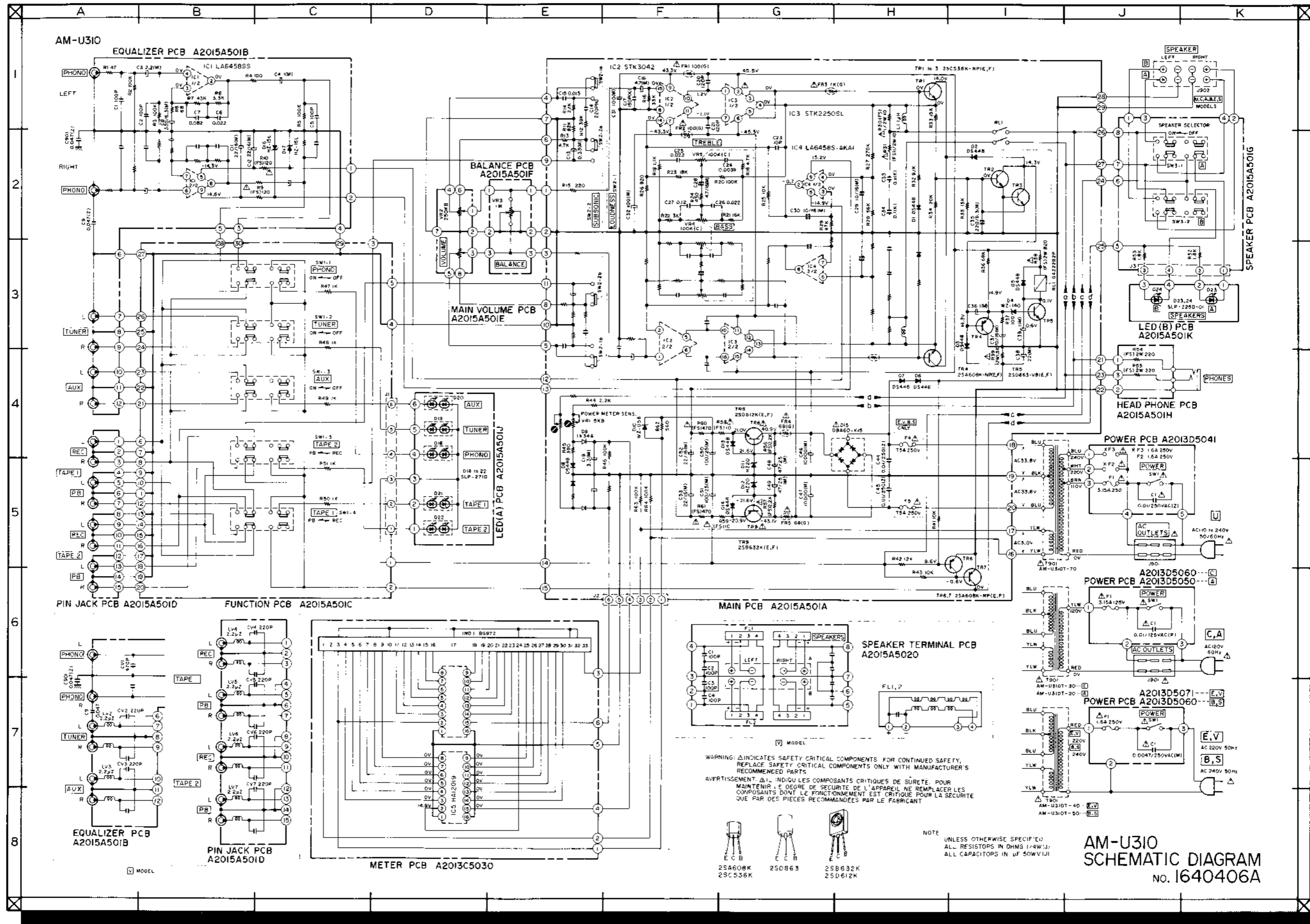

WARNING: Δ INDICATES SAFETY CRITICAL COMPONENTS FOR CONTINUED SAFETY. REPLACE SAFETY CRITICAL COMPONENTS ONLY WITH MANUFACTURER'S RECOMMENDED PARTS.
 AVERTISSEMENT: Δ IL INDIQU LES COMPOSANTS CRITIQUES DE SÛRETÉ. POUR MAINTENIR LE DEGRÉ DE SÛRETÉ DE L'APPAREIL, NE REMPLACER LES COMPOSANTS DONT LE FONCTIONNEMENT EST CRITIQUE POUR LA SÛRETÉ QUE PAR DES PIÈCES RECOMMANDÉES PAR LE FABRICANT.

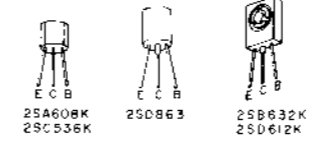

NOTE: UNLESS OTHERWISE SPECIFIED, ALL RESISTORS IN OHMS (1/4W); ALL CAPACITORS IN UF (50WV/1)

AM-U310 SCHEMATIC DIAGRAM NO. 1640406A