

SERVICE MANUAL

PARTS LIST

AKAI SURROUND STEREO TAPE DECK

MODEL **2020-SS**



SURROUND STEREO TAPE DECK

MODEL 202D-SS

SECTION 1	SERVICE MANUAL	2
SECTION 2	PARTS LIST	33
SECTION 3	SCHEMATIC DIAGRAM	60

SECTION 1

SERVICE MANUAL

TABLE OF CONTENTS

I.	SPECIFICATIONS	3
II.	MEASURING METHOD	4
	1. TAPE SPEED DEVIATION	4
	2. WOW AND FLUTTER	4
	3. FREQUENCY RESPONSE	4
	4. SIGNAL TO NOISE RATIO	4
	5. TOTAL HARMONIC DISTORTION FACTOR	5
	6. CROSS TALK	5
	7. ERASE RATIO	5
III.	DISMANTLING OF UNIT	6
IV.	SYSTEM CONTROL CIRCUIT OPERATION	8
	1. STOP MODE	15
	2. FORWARD PLAYBACK MODE	15
	3. FROM FWD TO REV PLAYBACK, AND REV PLAYBACK MODE	15
	4. FROM REVERSE TO FORWARD PLAYBACK	15
	5. RECORDING MODE	15
	6. FAST FORWARD AND REWIND MODE	17
	7. MUTING CIRCUIT OPERATION	17
V.	MECHANISM ADJUSTMENTS	18
	1. REEL TABLE HEIGHT ADJUSTMENT	19
	2. PINCH WHEEL PRESSURE MEASURING METHOD	19
	3. BRAKE TENSION ADJUSTMENT	19
	4. LEFT AND RIGHT REEL MOTOR TENSION AT VARIOUS OPERATING MODES	20
	5. FLYWHEEL LOOSE PLAY ADJUSTMENT	20
	6. FLYWHEEL BELT POSITION ADJUSTMENT	20
VI.	HEAD ADJUSTMENTS	21
	1. HEAD HEIGHT ADJUSTMENT	21
	2. RECORDING/PLAYBACK HEAD SLANT ADJUSTMENT	21
	3. RECORDING/PLAYBACK HEAD AZIMUTH ALIGNMENT ADJUSTMENT	21
VII.	AMPLIFIER ADJUSTMENTS	23
	1. PLAYBACK LEVEL ADJUSTMENT	23
	2. RECORDING LEVEL ADJUSTMENT	24
	3. BIAS LEAK ADJUSTMENT	24
	4. FREQUENCY RESPONSE ADJUSTMENT	24
	5. RECORDING BIAS FREQUENCY MEASURING METHOD	24
	6. 4-CHANNEL PHASE CHECK	24
VIII.	D.C. RESISTANCE OF VARIOUS COILS	25
IX.	COMPOSITE VIEWS OF COMPONENTS	26

I. SPECIFICATIONS

An asterisk next to a figure indicates the minimum guaranteed performance.

TRACK SYSTEM	4-track 4-channel stereo system 4-track 2-channel stereo system		
TAPE SPEED	7-1/2 ips (19 cm/sec.) $\pm 0.8\%$ 3-3/4 ips (9.5 cm/sec.) $\pm 1\%$		
WOW AND FLUTTER	Less than 0.08%(*0.12%) RMS at 7-1/2 ips Less than 0.12%(*0.25%) RMS at 3-3/4 ips		
TOTAL WOW AND FLUTTER	Less than 0.18% RMS at 7-1/2 ips (SCOTCH #175 TAPE, 3,000 Hz recording and playback)		
FREQUENCY RESPONSE	S.R.T. TAPE	40 to 25,000 Hz ± 3 dB at 7-1/2 ips 40 to 15,000 Hz ± 3 dB at 3-3/4 ips	
	REGULAR TAPE	40 to 22,000 Hz ± 3 dB at 7-1/2 ips 40 to 13,000 Hz ± 3 dB at 3-3/4 ips	
TOTAL DISTORTION FACTOR	Less than 1.5% *Less than 3% at 1,000 Hz O VU recording		
OUTPUTS	LINE OUTPUT	1.228V(4 \pm 1 dB) at FWD mode, 4 \pm 1.5 dB at REV mode, using a 250 Hz O VU pre-recorded tape/7-1/2 ips	
	DIN OUTPUT	610 mV(-2 dB), using a 250 Hz pre-recorded tape	
INPUTS	MIC INPUT	More than 0.5 mV(*0.6 mV)	
	LINE INPUT	More than 100 mV	
	DIN INPUT	More than 5 mV(low) More than 100 mV(high)	
RECORDING PLAYBACK LEVEL	1.228V(4 \pm 2 dB) at 7-1/2 ips, 1,000 Hz O VU recording		
S/N RATIO	Better than 50 dB *Better than 47 dB at 7-1/2 ips *Better than 46 dB at 3-3/4 ips		
TOTAL S/N RATIO	Better than 45 dB at 7-1/2 ips		
CROSS TALK	Better than 43 dB(*40 dB) at 1,000 Hz 3 VU recording		
ERASE RATIO	Better than 70 dB		
RECORDING BIAS FREQUENCY	82 \pm 5 kHz		
BIAS LEAK	Less than -30 VU (4 channel) Less than -20 VU (2 channel)		
REVERSING TIME	2 to 3 seconds		
RECORDING CAPACITY	45 min. 4 channel stereo recording, using a 1,800 ft. tape at 7-1/2 ips		
F. FWD AND RWD TIME	110/90 sec., using a 1,800 ft. tape at 50/60 Hz		
MOTORS	CAPSTAN MOTOR	2 speed Hysteresis Synchronous Motor Type: HM2-16MC (winterized) 4-8 pole Revolutions: 1,500/1,800 r.p.m. at 50/60 Hz 750/900 r.p.m. at 50/60 Hz	
	REEL MOTORS	Two 6-pole eddy current outer rotor motors Type: 24XO-MR Revolutions: 930/1,120 r.p.m. at 50/60 Hz	
HEADS	FULL TRACK ERASE HEAD	Type: EF-210 Gap: 0.2 mm W Gap Impedance: 360 Ω \pm 10% at 100 kHz D.C. Resistance: 2.8 Ω	
	4 TRACK ERASE HEAD	Type: E4-260 Gap: 0.2 mm W Gap Impedance: 195 Ω \pm 10% at 100 kHz D.C. Resistance: 1.6 Ω	
	4 TRACK RECORDING/PLAYBACK HEAD	Type: P4-50 Gap: 2 microns Impedance: 1,200 Ω \pm 15% at 1 kHz D.C. Resistance: 160 Ω	
TRANSISTORS	2SC711(E)(F) ... 19	2SC1098(L) ... 1	2SC1312(G)(H) ... 16
DIODES	1N34A ... 5 10D2 ... 1	1S2473VE ... 10 10D4 ... 1	10D05 ... 4 WZ713 ... 1
ZENER DIODES	WZ240 ... 1	YZ088A ... 4	
POWER SUPPLY	100 to 240V A.C. 50/60 Hz		
POWER CONSUMPTION	100W		
DIMENSIONS	391(W) x 442 (H) x 231 (D) mm (15.4" x 17.4" x 9.1")		
WEIGHT	18 kg (39.6 lbs.)		

NOTE: Specifications subject to change without notice.

II. MEASURING METHOD

1. TAPE SPEED DEVIATION

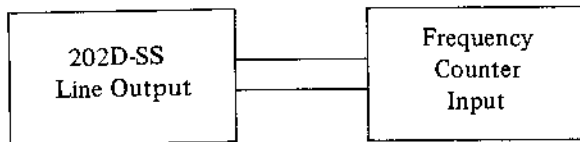

Fig. 1

As shown in Fig. 1, connect a Frequency Counter to the Line Output. Playback a 1,000 Hz pre-recorded test tape. Take a frequency counter reading at the beginning, middle, and end of tape winding during playback. The maximum value of these respective readings will represent tape speed deviation.

2. WOW AND FLUTTER

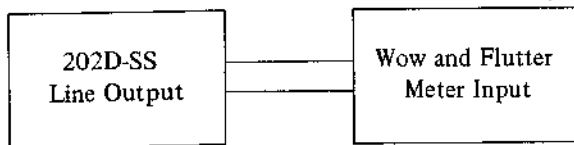

Fig. 2

Method A

As shown in Fig. 2, connect the Line output to the Input of a Wow and Flutter Meter. Playback a 3,000 Hz pre-recorded test tape and take a wow and flutter meter reading at the beginning, middle, and end of tape winding. The maximum value of these respective readings will represent the wow and flutter.

Method B

Supply a 3,000 Hz sine wave signal from an Audio Frequency Oscillator and make a recording on a blank tape at the beginning, middle, and end of tape winding. Rewind and playback the resultant signals. Measure wow and flutter with a Wow and Flutter Meter. (The wow and flutter value of Method B will be close to twice that of Method A.)

3. FREQUENCY RESPONSE

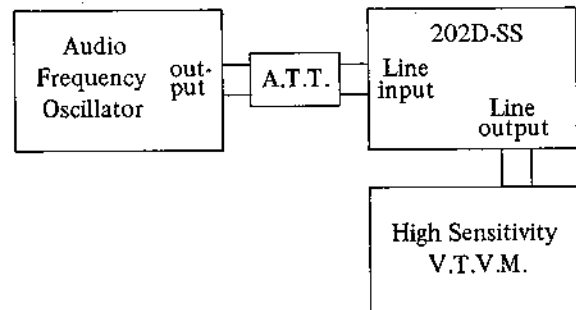

Fig. 3

For measuring frequency response, connect instruments as shown in Fig. 3 and proceed as follows:

- 1) Supply a 2,000 Hz sine wave signal to the Line input from an Audio Frequency Oscillator through an Attenuator.
- 2) Set tape deck to recording mode and turn recording level control volume to maximum. Adjust attenuator to obtain a +4 dB V.T.V.M. reading.
- 3) Under conditions described in 2) above, re-adjust attenuator so that the Line output is -16 dB, and record 30 to 23,000 Hz at 7-1/2 ips spot frequencies.
- 4) Rewind the tape and playback from the beginning. Take V.T.V.M. spot frequency readings and plot values on a graph.

NOTE: When measuring frequency response, new tape should be used.

4. SIGNAL TO NOISE RATIO

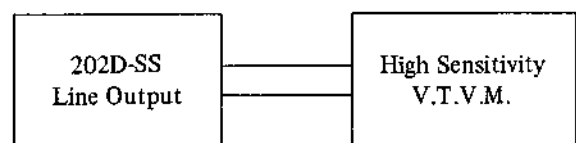

Fig. 4

As shown in Fig. 4, connect a High Sensitivity V.T.V.M. to the Line output. Playback a 250 Hz "O" VU pre-recorded test tape and measure the output. Then remove the tape and measure the noise level under the same condition. Convert each of the measured values into decibels.

5. TOTAL HARMONIC DISTORTION FACTOR

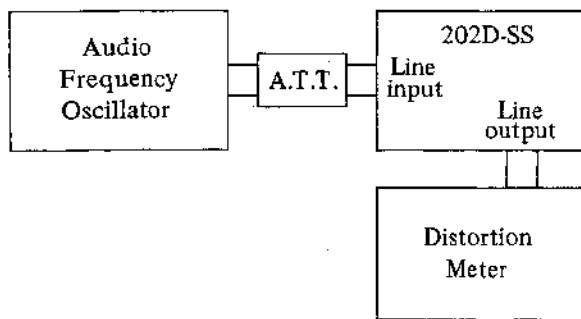

Fig. 5

Connect the measuring instruments as shown in Fig. 5 and record a 1,000 Hz sine wave signal at "0" VU. Playback the resultant signal and measure the overall distortion factor. Measure the noise level of the tape recorder without the tape. Connect the audio frequency oscillator directly to the distortion meter for measurement of the distortion factor of the oscillator. The required distortion factor can be obtained from the results of the above measurement by the following formula:

$$d_0 = d - d_1 - d_2$$

where, d_0 = Required distortion factor
 d = Overall distortion factor
 d_1 = Noise Level
 d_2 = Distortion factor of the oscillator

NOTE: When measuring the distortion factor, new tape should be used.

6. CROSS TALK (Cross talk between the channels)

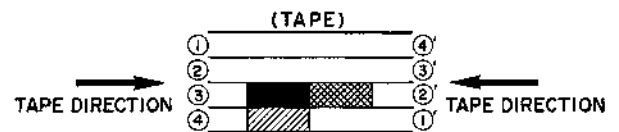

Fig. 6

As shown in Fig. 6, first record a 1,000 Hz sine wave signal on Track No. 3 at +3 VU level. Next, record under a non-input condition. Then, playback the tape on Tracks No. 3 and 4 (reversed condition of tape) through the B.P.F. (band pass filter, Sensitivity ... 1:1) and obtain a ratio between the two from the following formula:

$$C = 20 \log \frac{E_0}{E_2 - E_1} \text{ (dB)}$$

where, C = Desired cross talk ratio (dB)

E_0 = 1,000 Hz signal output level

E_2 = 1,000 Hz cross talk level

E_1 = Non-input signal recorded level

7. ERASE RATIO

As shown in Fig. 4, connect a High Sensitivity V.T.V.M. to the Line output. Playback a virgin tape and take a V.T.V.M. reading of the output level. Next, record a 1,000 Hz sine wave signal at +3 VU, then playback this recorded signal and take a V.T.V.M. reading of the output level. Next, using this pre-recorded tape, record under a non-input condition and take a reading of the noise level output of the erased signal and obtain a ratio between the two from the following formula:

$$E_r = 20 \log \frac{E_0}{E_2 - E_1} \text{ (dB)}$$

where, E_r = Desired erase ratio (dB)

E_0 = 1,000 Hz signal output level

E_2 = Non-input signal recorded level

E_1 = Virgin tape noise output level

III. DISMANTLING OF UNIT

In case of trouble, etc. necessitating disassembly, please disassemble in the order shown in photographs. Reassemble in reverse order.

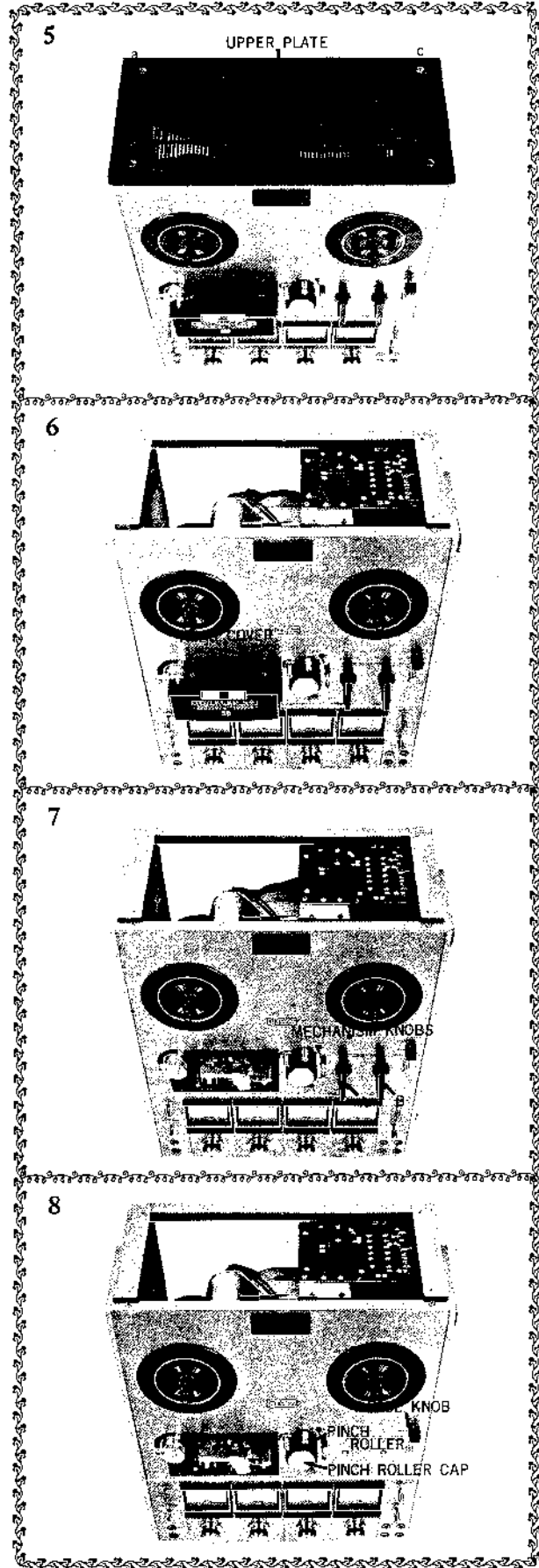
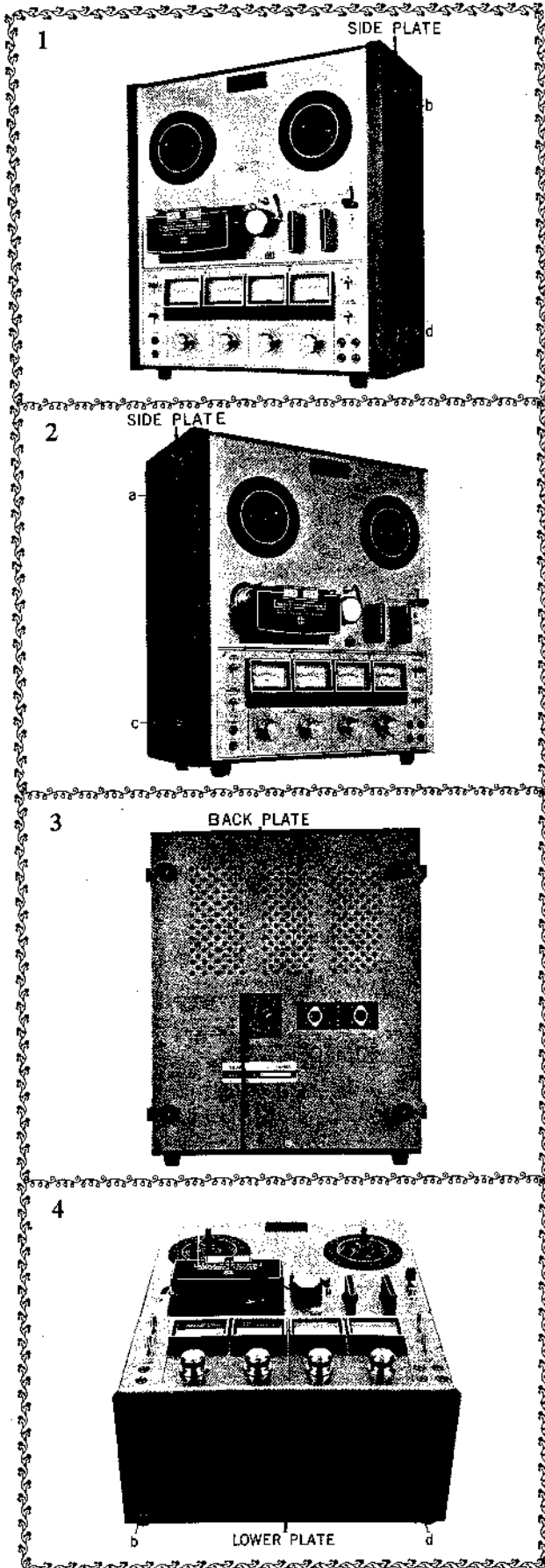

9

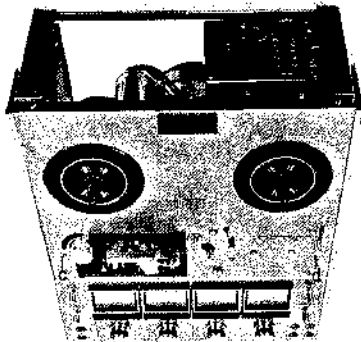

SCREWS

10

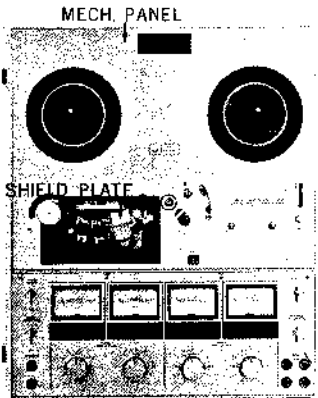

MECH. PANEL

SHIELD PLATE

11

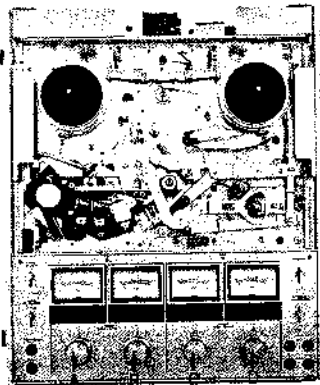

CONTROL KNOBS

12

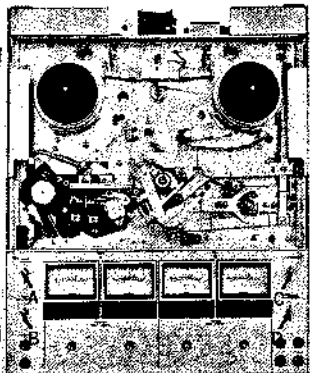

LEVER SW. KNOBS

13

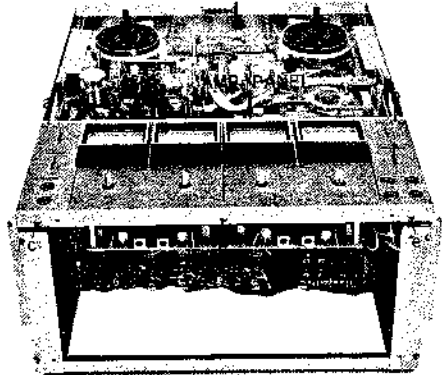

14

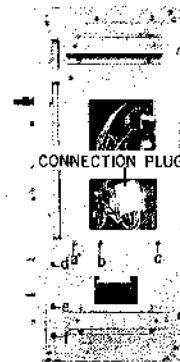

CONNECTION PLUG

SCREWS

15



SCREWS

16

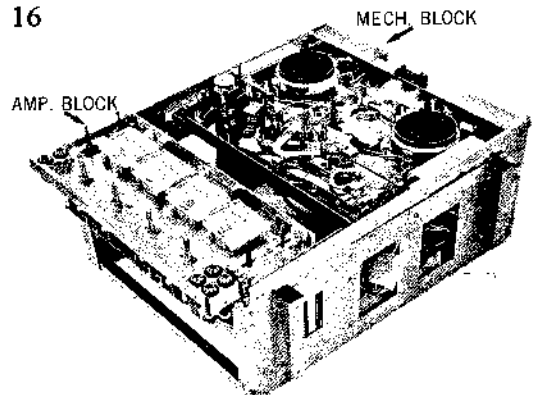

AMP. BLOCK

MECH. BLOCK

IV. SYSTEM CONTROL CIRCUIT OPERATION

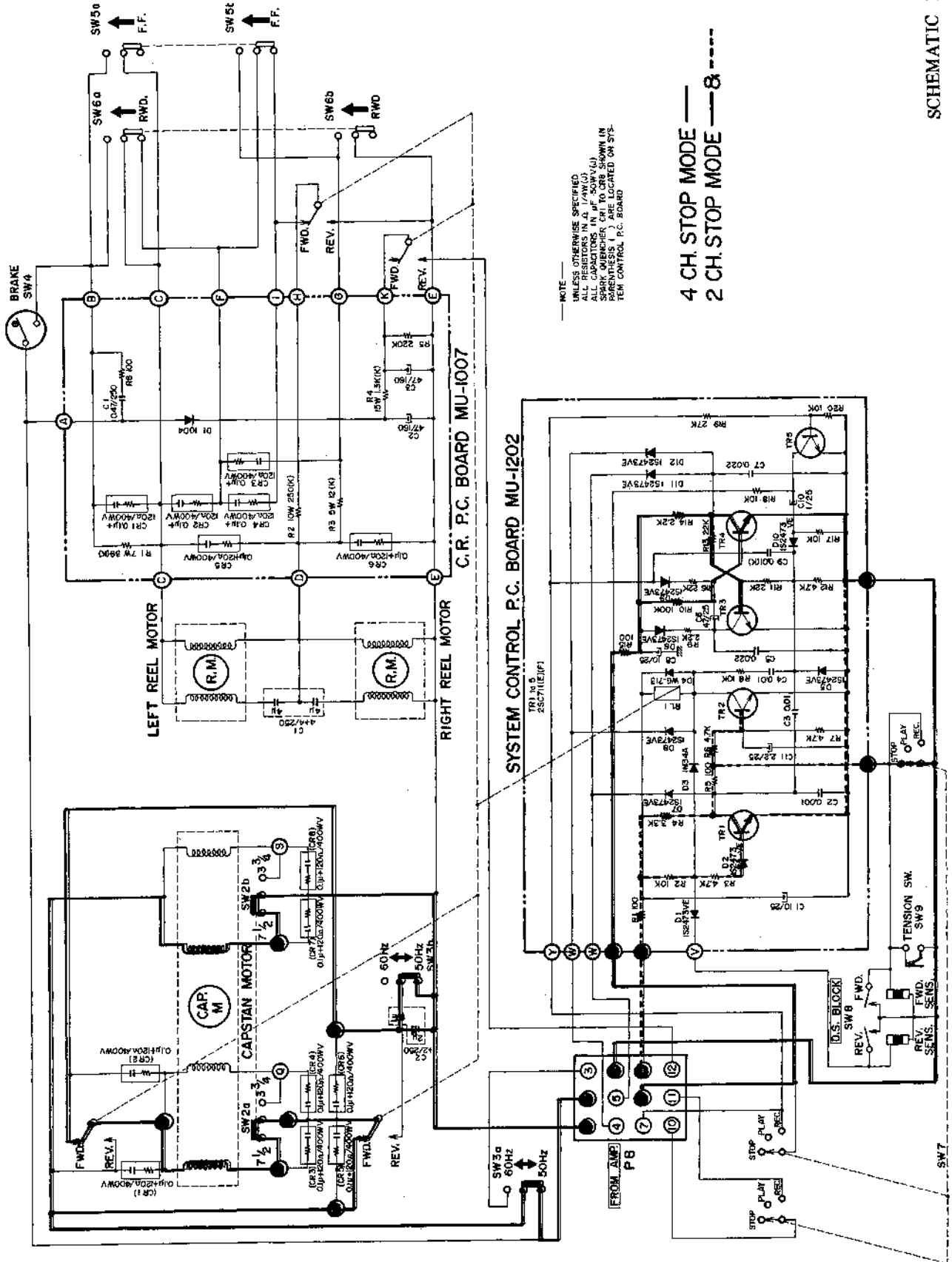

NOTE: UNLESS OTHERWISE SPECIFIED ALL RESISTORS IN Ω, 1/4W (1/2) ALL CAPACITORS IN μF, 50WV (50) SPARK QUENCHER CRT TO CRT SHOWN IN PARENTHESES. PARTS ARE LOCATED ON SYS. CONTROL P.C. BOARD.

4 CH. STOP MODE ———
2 CH. STOP MODE ———&-----

SCHEMATIC 1

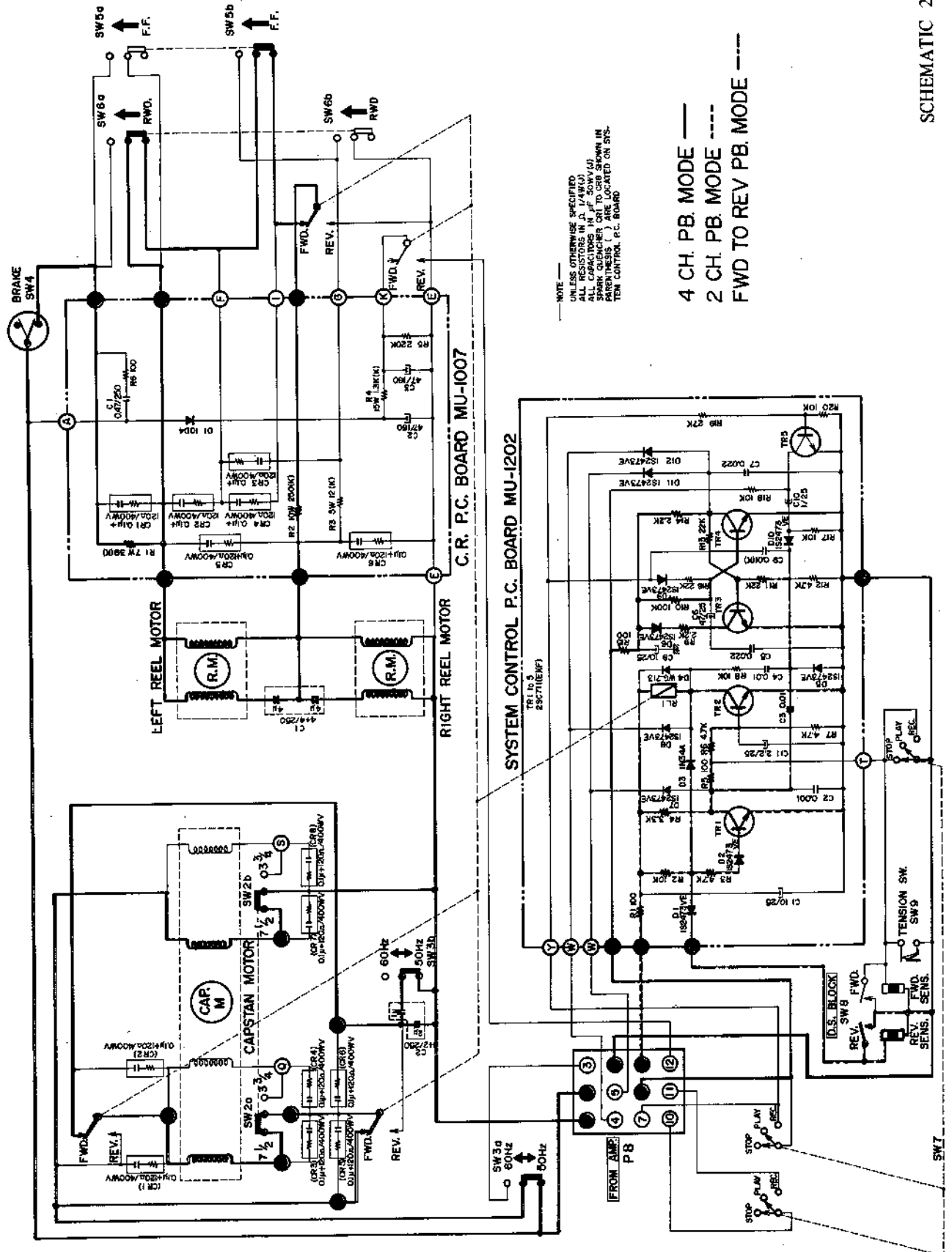

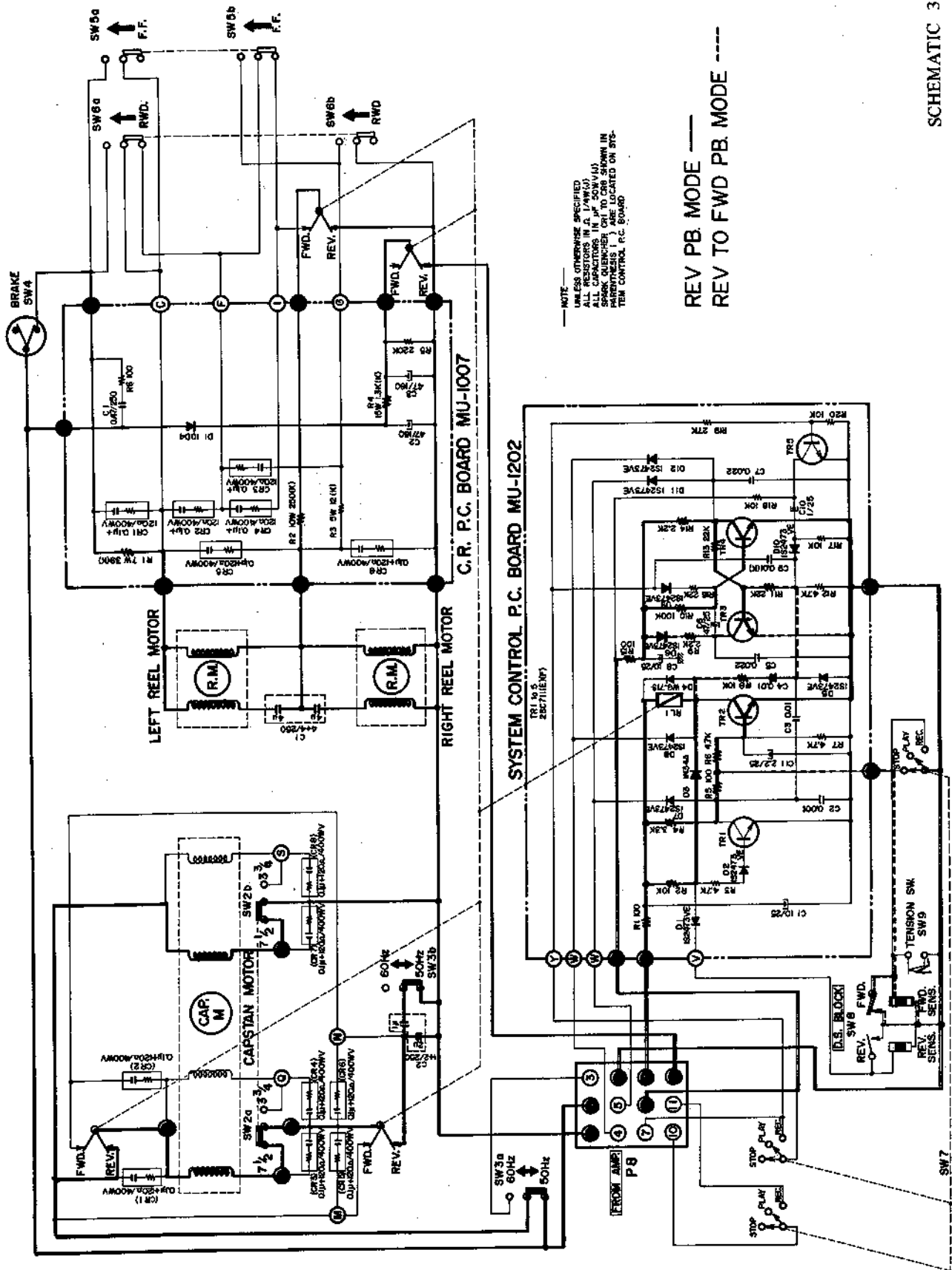

SCHEMATIC 3

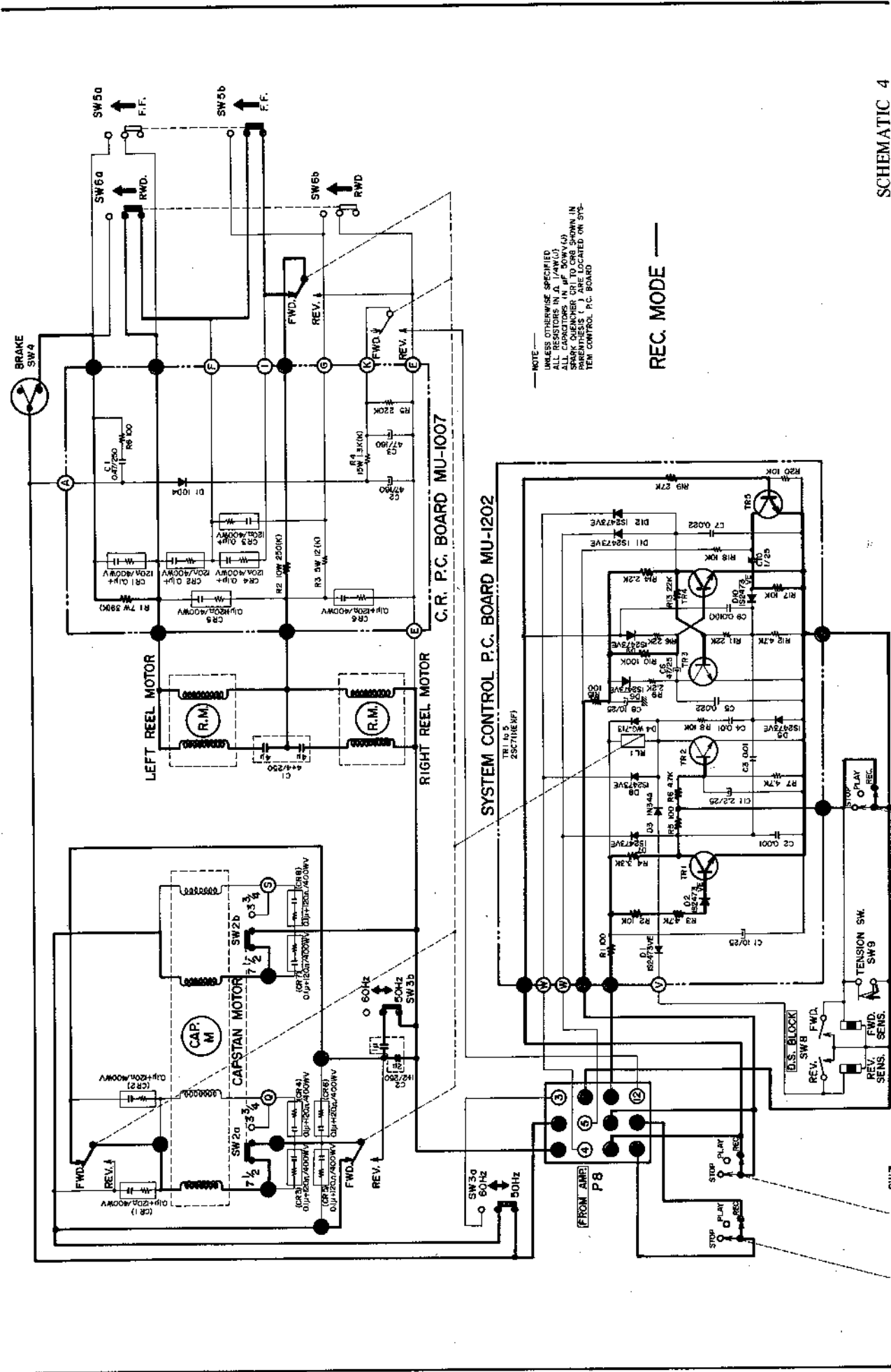

NOTE: UNLESS OTHERWISE SPECIFIED ALL RESISTORS IN Ω (AWG) ALL CAPACITORS IN μF (DWM) SPARK CLEANER OR TO CRG SHOWN IN CIRCUIT ARE LOCATED ON SYSTEM CONTROL P.C. BOARD

REC. MODE —

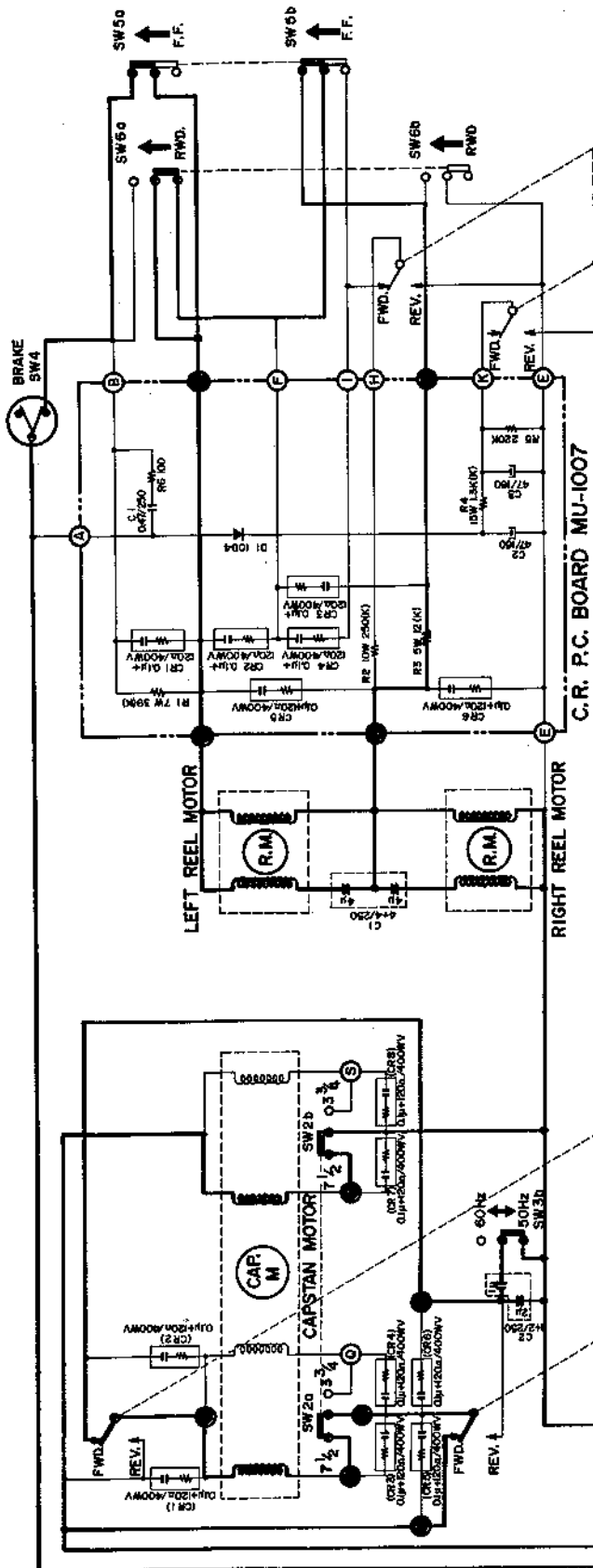

C.R. P.C. BOARD MU-1007

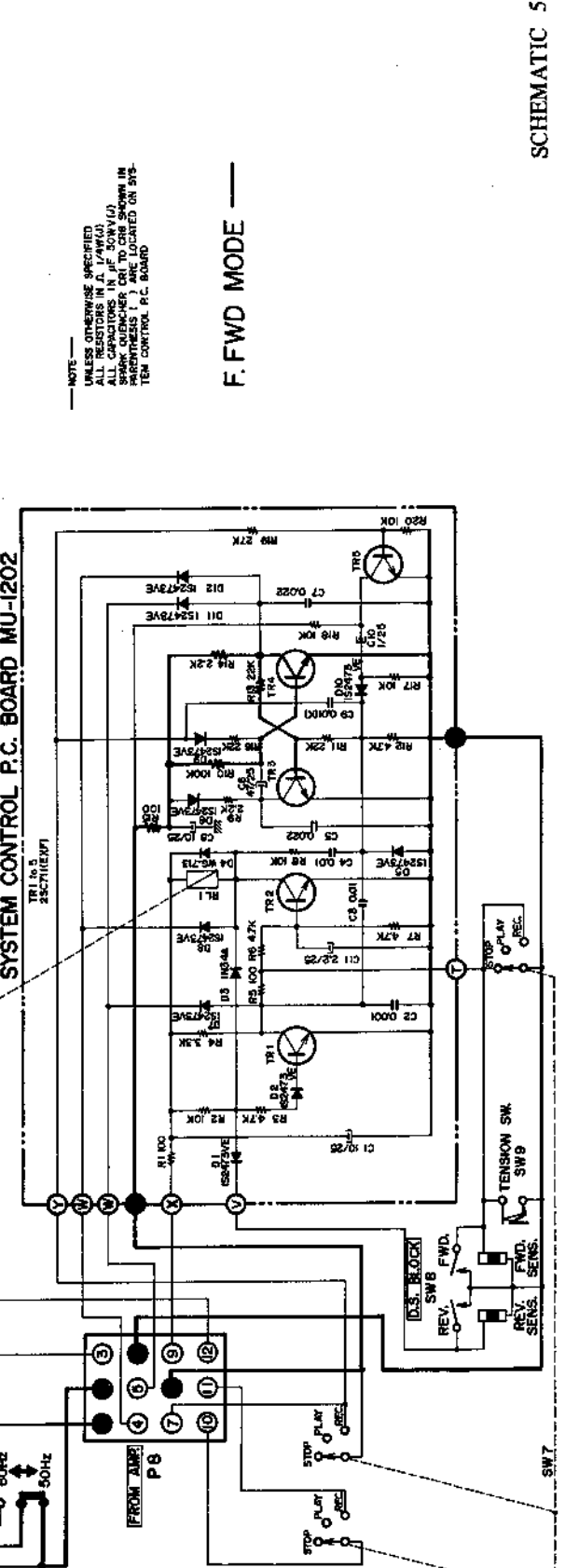

SYSTEM CONTROL P.C. BOARD MU-1202

NOTE
UNLESS OTHERWISE SPECIFIED
ALL RESISTORS IN Ω, 1/4W(1/2)
ALL CAPACITORS IN μF, 50V(1/2)
RESISTORS AND CAPACITORS IN
PARENTHESES ARE LOCATED ON SYS-
TEM CONTROL P.C. BOARD

F. FWD MODE

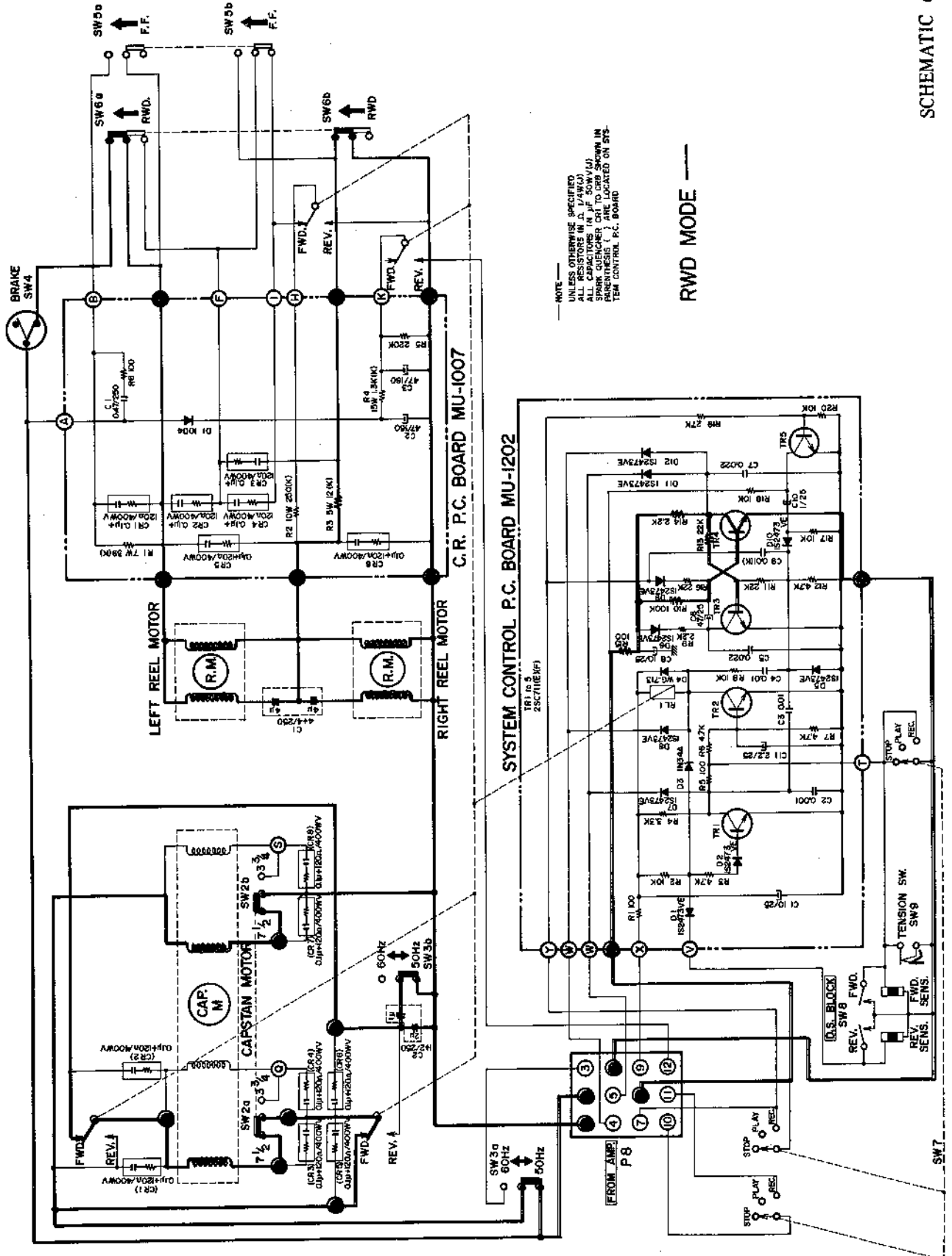

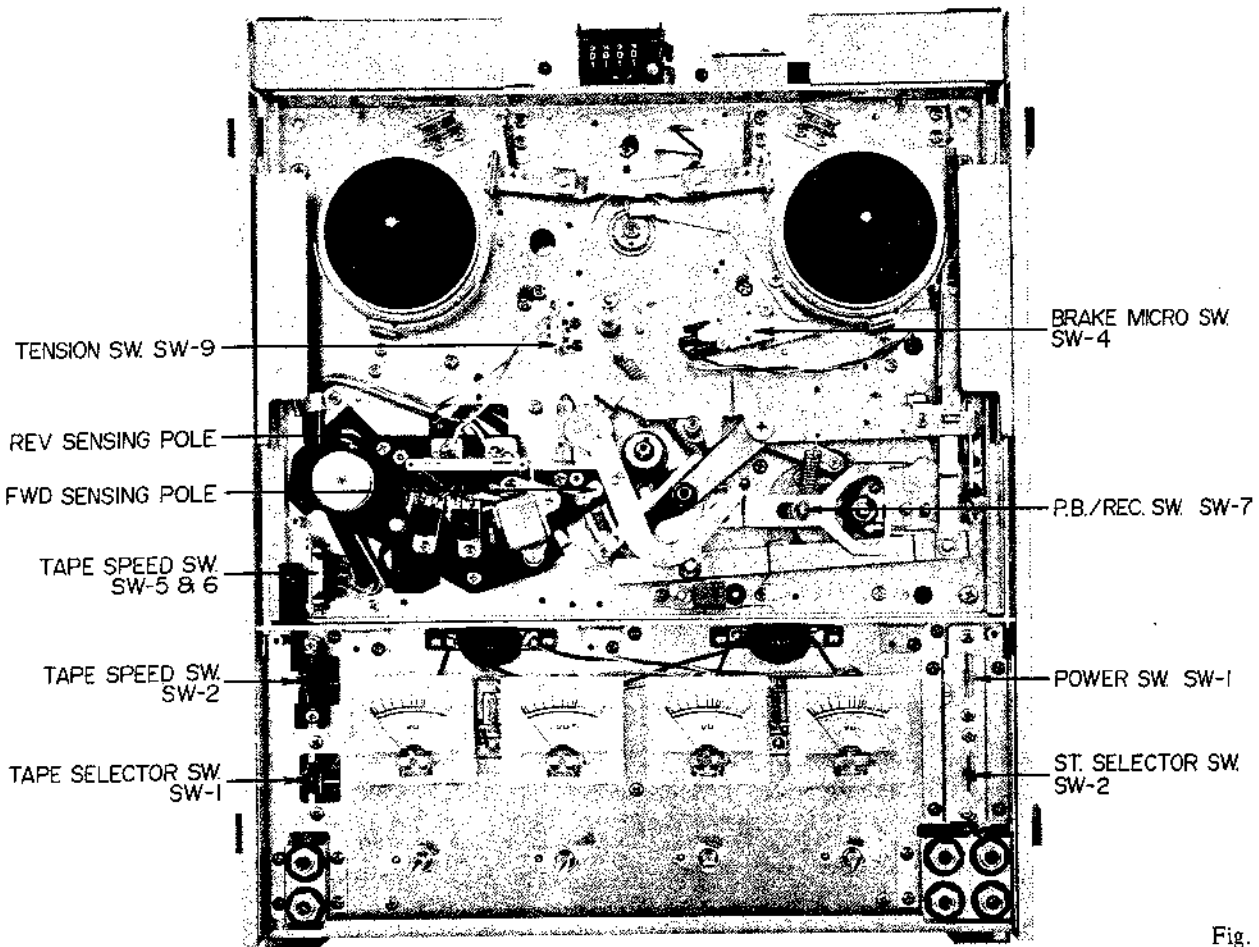

Fig. 7

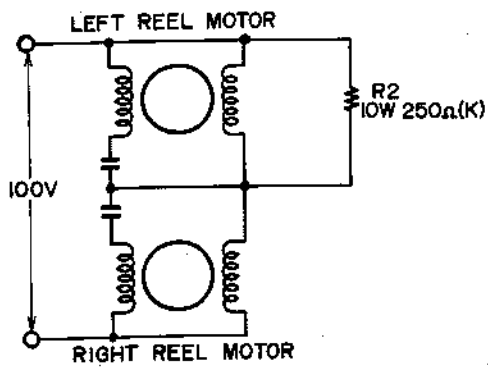

Fig. 8

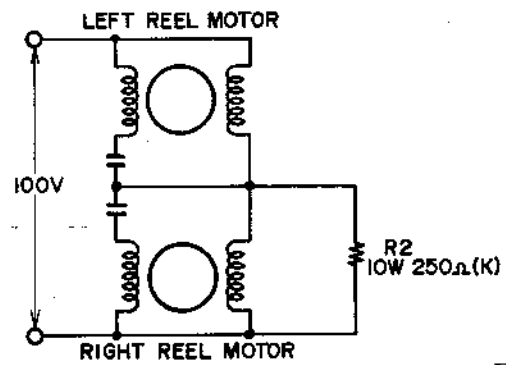

Fig. 9

1. STOP MODE (Refer to Schematic 1)

At stop mode, the various system control (hereinafter referred to as SYS.CON. transistors are maintained as follows: TR1(ON), TR2(OFF), TR3(OFF), and TR4(ON). Accordingly, the reverse relay connected to the collector of TR2 is OFF, and capstan motor revolutions are in forward direction. Also as TR4 is ON and TR4 collector voltage is roughly zero, and thus Diode D1 connected to the collector of TR4 (Playback Amp. P.C. Board) is turned OFF, the Playback Amp. Mute Circuit is also turned OFF. Both the supply and take-up reel motors are equipped with a Micro Switch SW4 which is activated to OFF and ON by the operation of the brake lever, and which at Stop Mode are turned OFF. Consequently, no voltage is supplied to either reel motor (both reel motors are connected in series).

When at stop mode, switching by means of P.B./REC Switch SW-7 does not take place because the base of SYS.CON.TR2 is grounded and maintained at OFF condition. That is to say, capstan motor revolutions will not reverse even when a REV Button is depressed. When the tension lever is raised, Tension Switch SW-9 is turned OFF. Thus, when no tape is loaded, this switch is ON. Also, because Tension Switch SW-9 is installed in parallel with P.B./REC Switch SW-7, when SW-7 is at stop mode, if a tape is loaded, but not threaded through the Tension Lever and playback is effected, reverse mode cannot be effected when a REV Button is depressed. And, of course, reverse mode will not be effected when the sensing foil passes the sensing poles.

2. FORWARD PLAYBACK MODE (Refer to Schematic 2)

When the P.B./REC Switch is at PLAY position, the various SYS.CON. transistors are maintained as follows: TR1(ON), TR2(OFF), TR3(OFF), and TR4(ON), i.e., functionally the same as at stop mode. The difference is that the base of TR2 which was grounded by P.B./REC Switch SW-7 is now open. That is to say, when TR1 is turned OFF and TR1 collector voltage increases, bias is supplied to TR2, and TR2 is turned ON.

Accordingly, while TR1 is (ON) and TR2 (OFF) (FWD Playback mode), capstan motor revolutions are in forward direction. Also Micro Switch SW-4 is ON, and voltage is supplied to both reel motors.

At FWD playback mode, an R2(10W, 250Ω) resistor is in parallel with left reel motor winding. That is to say, the left reel motor resistance differs from the right reel motor resistance due to the R2(10W, 250Ω) resistor which is parallel with the left reel motor as shown in Fig. 8. In short, the voltage supplied to the left reel motor is low and FWD playback mode is maintained.

3. FROM FWD TO REV PLAYBACK, AND REV PLAYBACK MODE (Refer to Schematic 2, 3)

When the sensing tape passes the reverse sensing poles or when the REV Button is depressed, the base of TR1 is biased at zero electrical potential and TR1 is instantly turned OFF, TR1 collector voltage increases and bias is applied to the base of TR2, TR2 is turned ON, and Reverse Relay RL1 is turned ON. In this TR1 and TR2 circuit, TR1 is maintained at OFF and TR2 at ON by means of Diode D3(IN34A). (Refer to Schematic Diagram-3)

By means of the reverse relay function, current flows from the reverse direction to the capstan motor sub coil, and reverse revolutions begin. Also, at FWD playback time, Resistor R2(10W, 250Ω) connected in parallel with the left reel motor becomes parallel with the right reel motor. (Refer to Fig. 9)

At this condition, reverse playback begins and is maintained, and the capstan motor revolutions begin reversing from forward direction. For normalized and stable revolutions, flywheel inertia at time of forward revolutions and flywheel mass when reverse revolutions begin is applied so that stabilized tape speed is not immediate, for this reason the signal output circuit must be muted until capstan motor speed is stabilized. (Refer to MUTING CIRCUIT OPERATION explanation)

Solenoid Plunger SL-1 also operates to switch Reverse Switch SW-1. In other words, the P.B. Amp. P.C. Board output is switched by means of Reverse Switch SW-1. (Refer to Fig. 10)

4. FROM REVERSE TO FORWARD PLAYBACK (Refer to Schematic 3)

When the sensing tape passes the FWD sensing pole or when the FWD Button is depressed and the base of TR2 becomes biased at zero electrical potential, TR2 is instantly turned OFF, and reverse relay RL-1 is also turned OFF.

Diode D3(1N34A) is also inverse biased, TR1 base current passes R2(10 kΩ), R3(4.7 kΩ), and D2 (1S2473VE) and is biased, and TR1 is turned ON and maintained. Consequently, reverse relay RL-1 returns to its original condition (FWD P.B.) and FWD playback mode is effected. Refer to MUTING CIRCUIT OPERATION for mute function during change from REV to FWD playback.

5. RECORDING MODE (Refer to Schematic 4)

SYS.CON. operation at recording time is exactly the same as Stop mode.

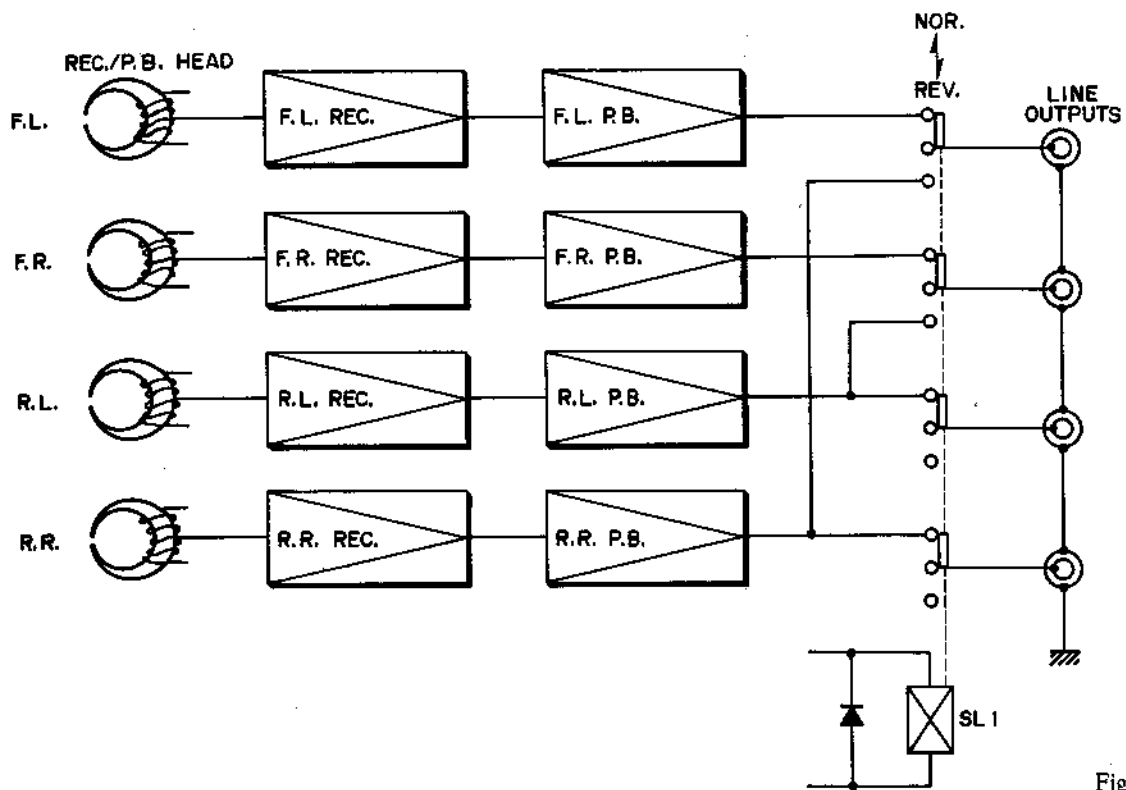
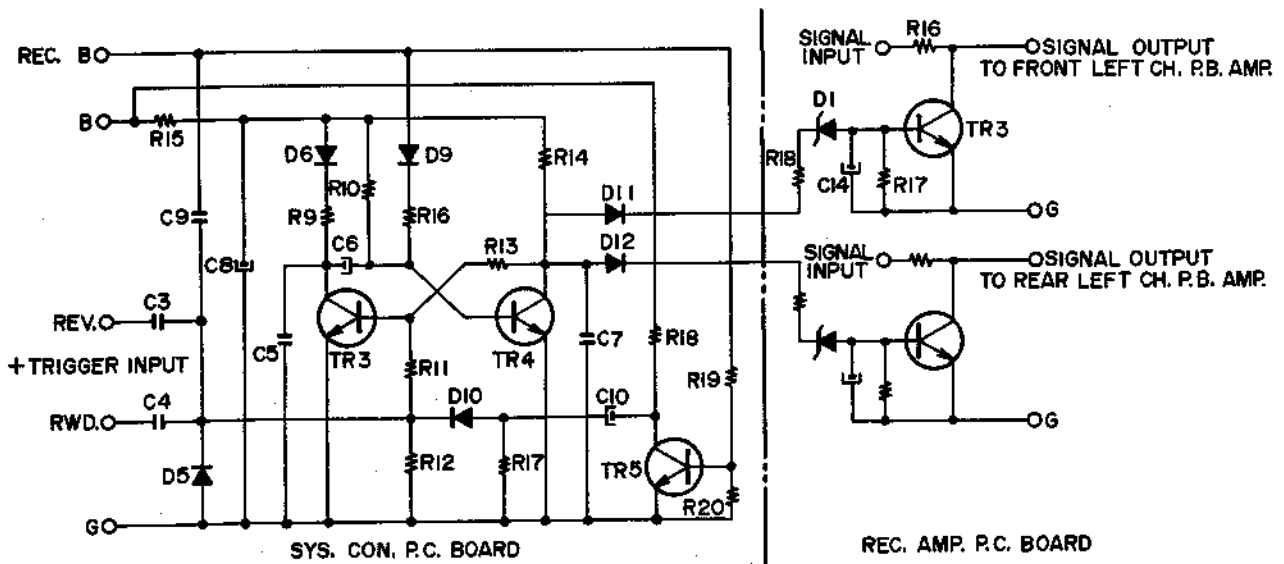

Fig. 10



SCHEMATIC 7

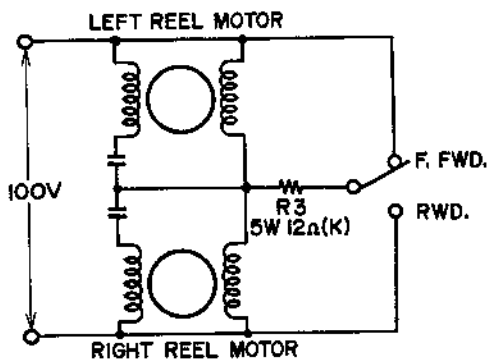

Fig. 11

6. FAST FORWARD AND REWIND MODE (Refer to Schematic 5, 6)

In this case, SYS.CON. operation is also exactly the same as Stop mode. However, the voltage supply to both reel motors are as shown in Fig. 11.

7. MUTING CIRCUIT OPERATION (Refer to Schematic 2, 3, and 7)

As shown in Schematic Diagram-7, the muting circuit consists of an electronic switch from Recording Amp. P.C. Board Transistor TR3 and a one-shot multi-vibrator comprised of SYS.CON. P.C. Board TR3 and TR4.

When stabilization is attained, TR3 of the one-shot multi-vibrator is turned OFF, and TR4 turned ON. Accordingly, the collector voltage of TR4 is lowered, Zener Diode D1 is biased in reverse direction, and TR3 of Recording Amp. P.C. Board is turned OFF.

If Button SW-8 is now depressed for FWD to REV Playback, or REV to FWD Playback, a charge current flows to condenser C3 or C4. That is to say, the positive direction trigger signal is introduced at the base of TR3 of SYS.CON. P.C. Board and therefore, the one-shot multi-vibrator which is comprised of TR3 and TR4 is inverted and, after a certain period of time (2 to 3 seconds), again returns to its stabilized condition. While this one-shot multi-vibrator is inverted (while TR4 is OFF), because TR4 collector voltage is high, the voltage exceeding the Zener Point of Zener Diode D1 is applied to the cathode of D1 and D1 assumes a lead-through condition. Thus, electronic switch Transistor TR3 is turned ON, and the signal is muted. (The internal resistance of electronic switch TR3 at lead-through time is extremely low.)

At recording time, a charge current flows to condenser C9 in the same way as described above. That is to say, the one-shot multi-vibrator is inverted and the mute circuit functions. Also when stop is effected from recording mode, TR5 is turned OFF, and because a charge current flows to C10 through R18, the mute circuit functions. Thus, at recording time or when returned to stop mode, these functions prevent a click noise from being recorded on the tape.

V. MECHANISM ADJUSTMENTS

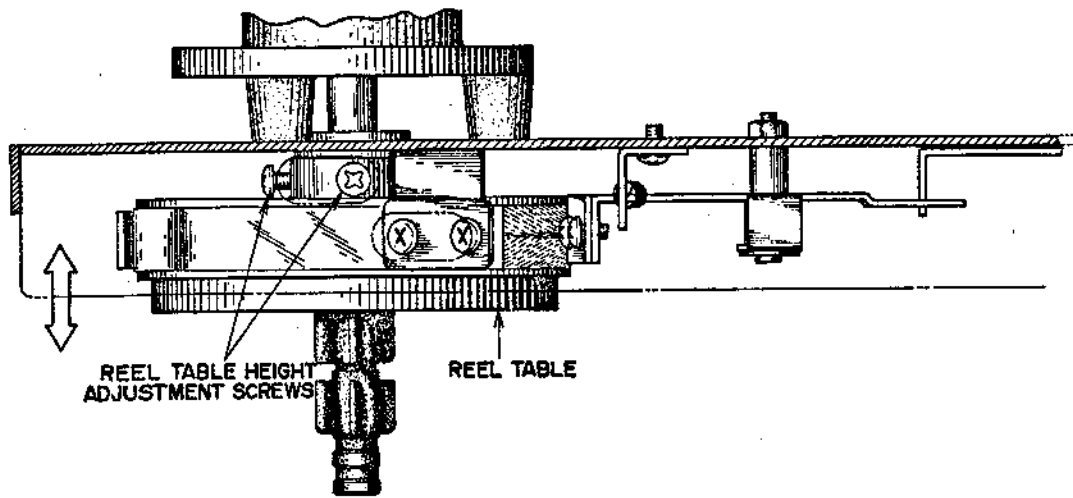

Fig. 12

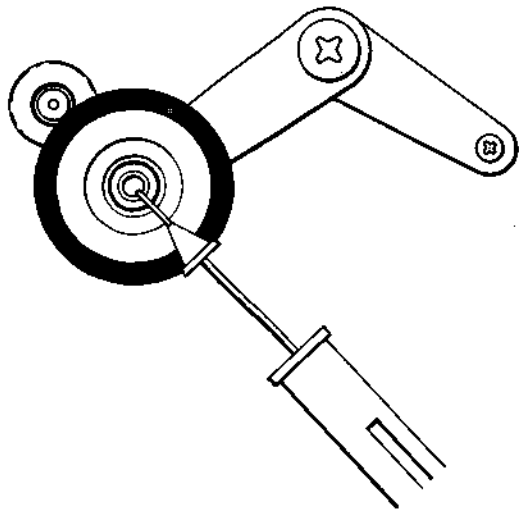

Fig. 13

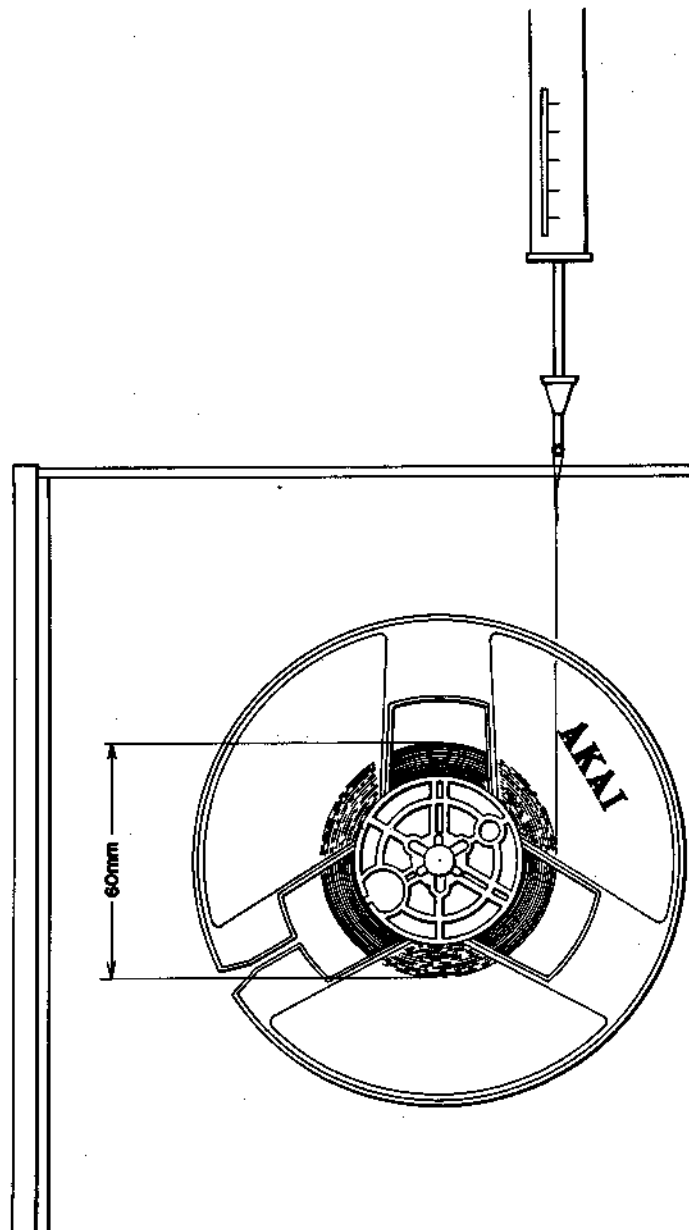

Fig. 14

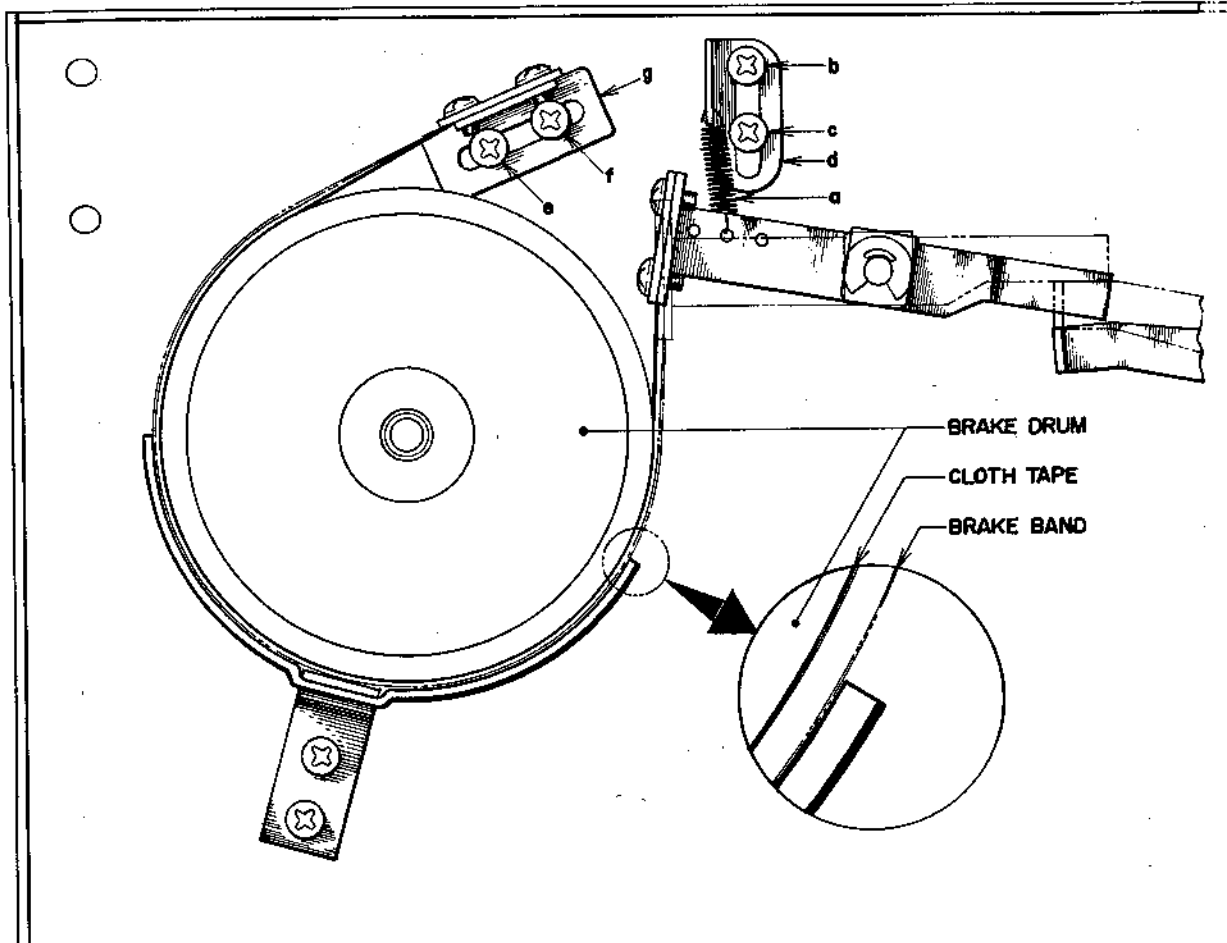

Fig. 15

1. REEL TABLE HEIGHT ADJUSTMENT

As shown in Fig. 12, loosen reel table height adjustment screws, and adjust reel table height by moving table in direction of arrow and positioning so that the tape winds in the center of the reel.

2. PINCH WHEEL PRESSURE MEASURING METHOD

Measure pinch wheel pressure with a tension gauge as shown in Fig. 13. Read the value on the tension gauge as soon as the pinch wheel separates from the tape and tape travel stops. Ideal pinch wheel pressure is 1.8 kg.

3. BRAKE TENSION ADJUSTMENT

- 1) As shown in Fig. 14, use a 60 mm diameter tape wound on a 5" reel and measure the brake tension with a tension gauge. Ideal brake tension is from 300 to 370 grams.
- 2) Brake tension adjustment can be made as follows: (Refer to Fig. 15)
 - a) Change position of suspended spring (a).
 - b) Loosen screws (b) and (c) and adjust the vertical position of spring suspension metal (d).
 - c) Loosen screws (e) and (f) and adjust the horizontal position of brake band suspension metal (g).
 - d) Only the left side is shown in Fig. 15, but the right side must be adjusted in the same way.

NOTE: In making brake tension adjustment, at all modes except stop mode, confirm that the brake band completely separates from the cloth tape on the brake drum. (Refer to Fig. 15)

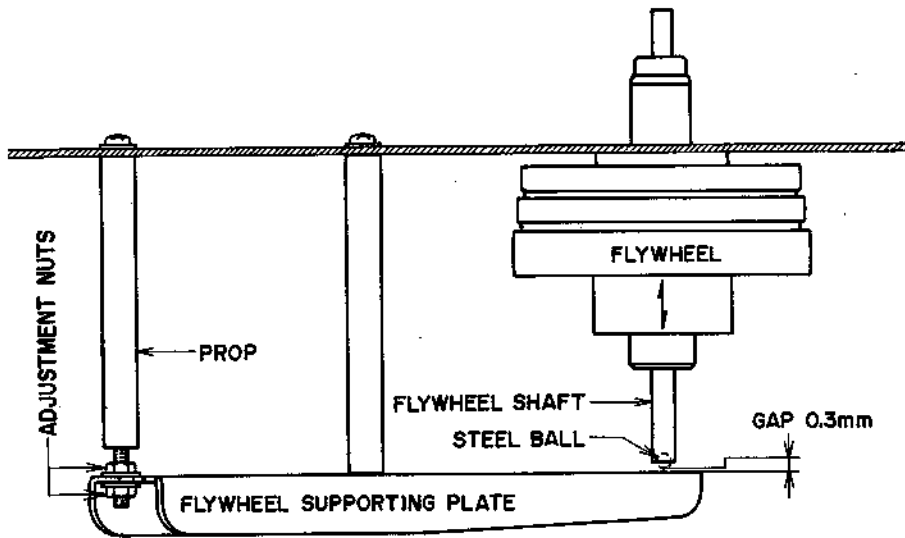

Fig. 16

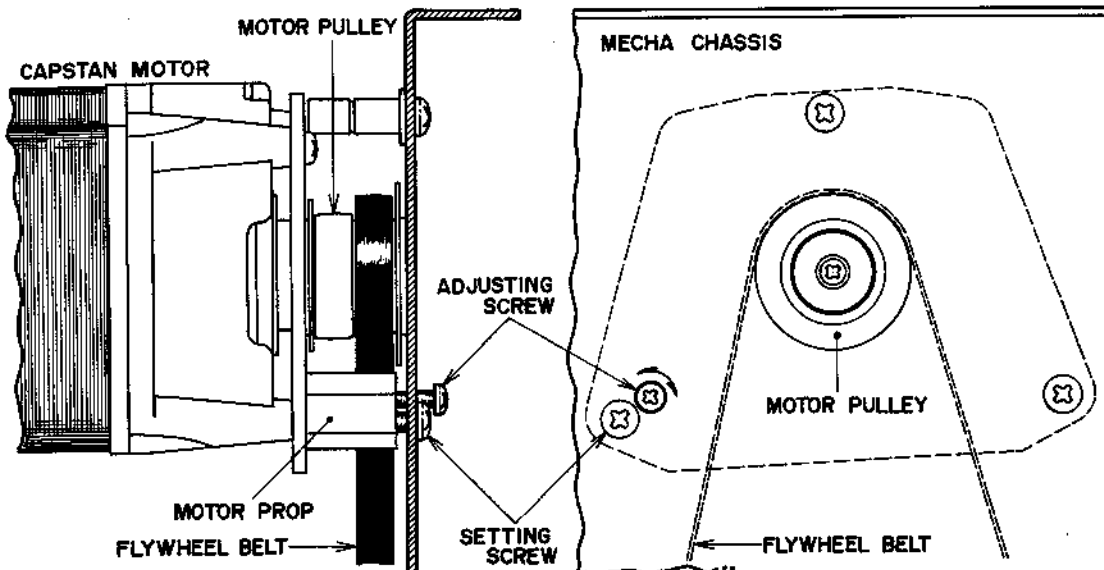

Fig. 17

4. LEFT AND RIGHT REEL MOTOR TENSION AT VARIOUS OPERATING MODES

Reel Motor Mode	Left Reel Motor	Right Reel Motor
FWD P.B.	60g	180g
REV P.B.	180g	60g
F.FWD	10g	450g
RWD	450g	10g

Chart 1

5. FLYWHEEL LOOSE PLAY ADJUSTMENT

Turn the adjustment nuts to obtain a 0.3 mm gap between the steel ball and flywheel supporting plate when the flywheel is moved in the direction of the arrow as shown in Fig. 16.

6. FLYWHEEL BELT POSITION ADJUSTMENT

- 1) With capstan motor revolutions operating at Rev. mode, loosen setting screw and turn flywheel belt position adjustment screw until the flywheel belt comes to the center of the motor pulley. (Refer to Fig. 17)
- 2) Tighten setting screw to maintain center positioning of flywheel belt at Rev. mode.
- 3) Confirm that the flywheel belt runs on the center of the motor pulley at Fwd. mode also.

VI. HEAD ADJUSTMENTS

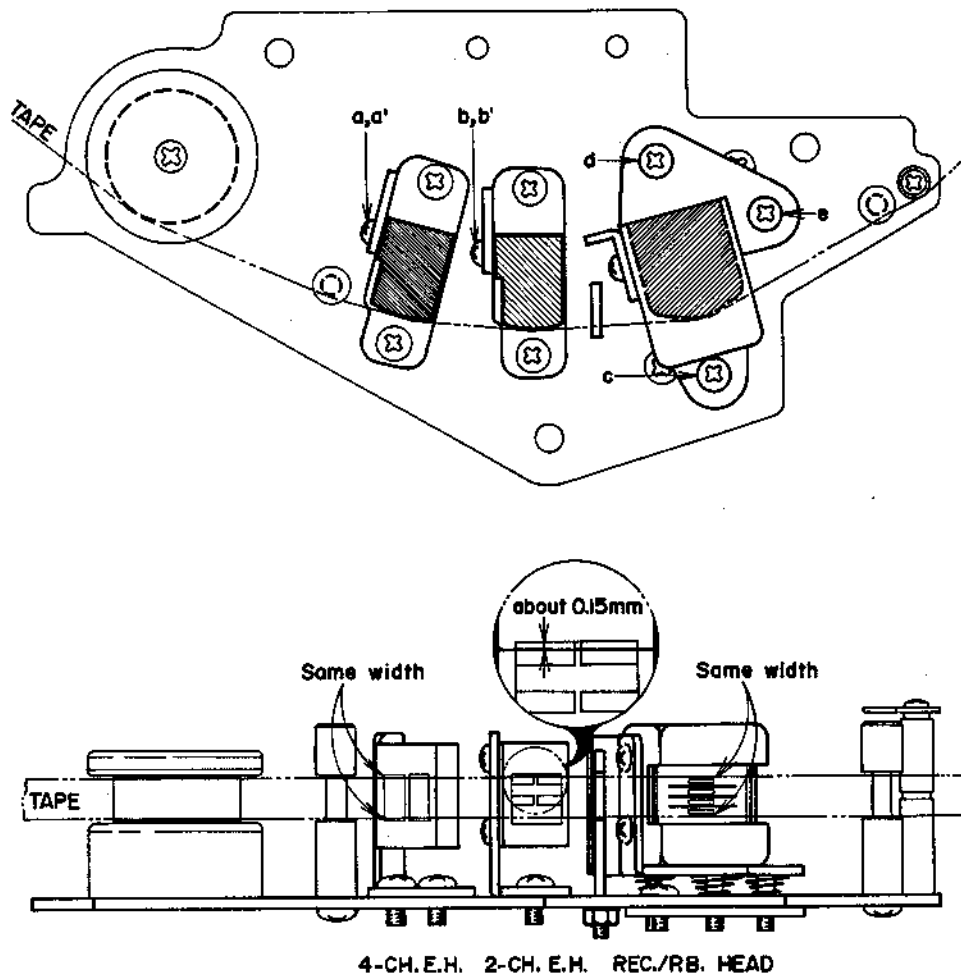

4-CH. E.H. 2-CH. E.H. REC./RB. HEAD

Fig. 18

1. HEAD HEIGHT ADJUSTMENT

(See Fig. 18)

1) Erase Head (2-CH)

Loosen Erase Head Screws (b) (b') and adjust Erase Head height so that the upper edge of the tape is about 0.15 mm lower than the upper Erase Head core.

2) Erase Head (4-CH)

Loosen Erase Head Screw (a) (a') and adjust Erase Head height so that the tape is equidistant in relation to the top and bottom edges of the Erase Head core (width between top edge of tape and top edge of head core is the same as the distance between the bottom edge of the tape and the bottom edge of the head core).

3) Recording/Playback Head

Adjust Recording/Playback Head Height by turning Recording/Playback Head Height Adjustment Screws (c) (d), to left and right until the width between the upper edge of Channel 1 Head Core and the upper edge of the tape is equal to the width between the lower edge of Channel 4 Head Core and the lower edge of the tape.

2. RECORDING/PLAYBACK HEAD SLANT ADJUSTMENT (See Fig. 18)

By turning Head Height Adjustment Screws (c) (d) to left and right, adjust so that the Recording/Playback Head contacts the tape surface at a right angle (head is at right angle in relation to tape surface).

3. RECORDING/PLAYBACK HEAD AZIMUTH ALIGNMENT ADJUSTMENT (See Fig. 18)

Connect a High Sensitivity V.T.V.M. to the Line Output and playback a Head Alignment Test Tape (8,000 Hz, 3-3/4 ips.). Adjust by turning Head Alignment Adjustment Screw (e) to left and right until the various line outputs reach maximum.

4. Repeat adjustments outlined in 1-3) as well as 2. and 3. above two or three times to obtain optimum adjusted condition.

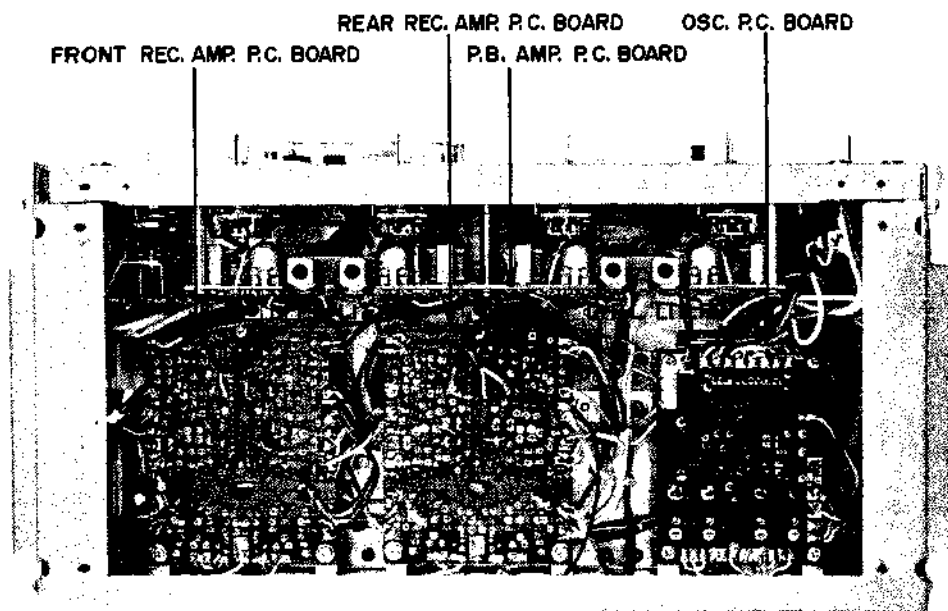



REF :   ARROW INDICATES MAX
 F.L. FRONT LEFT CHANNEL
 F.R. FRONT RIGHT CHANNEL
 R.L. REAR LEFT CHANNEL
 R.R. REAR RIGHT CHANNEL

Fig. 19

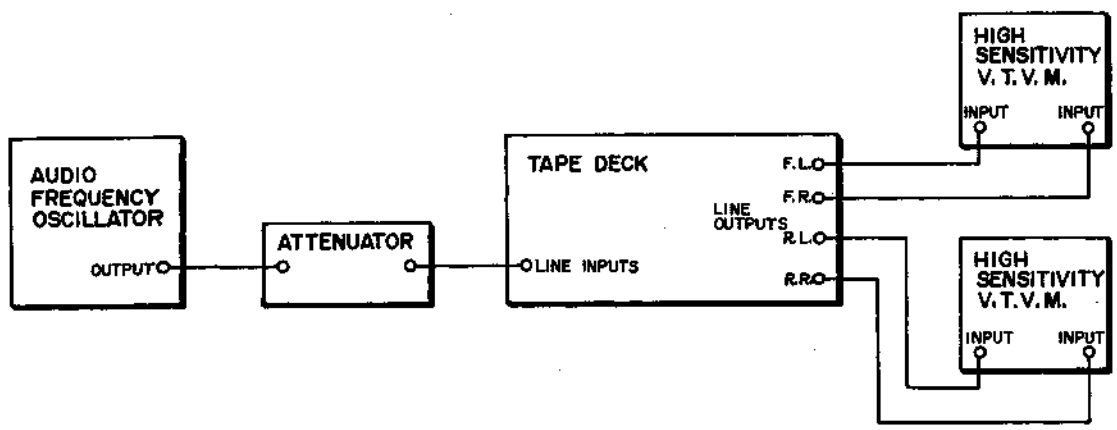

Fig. 20

VII. AMPLIFIER ADJUSTMENTS

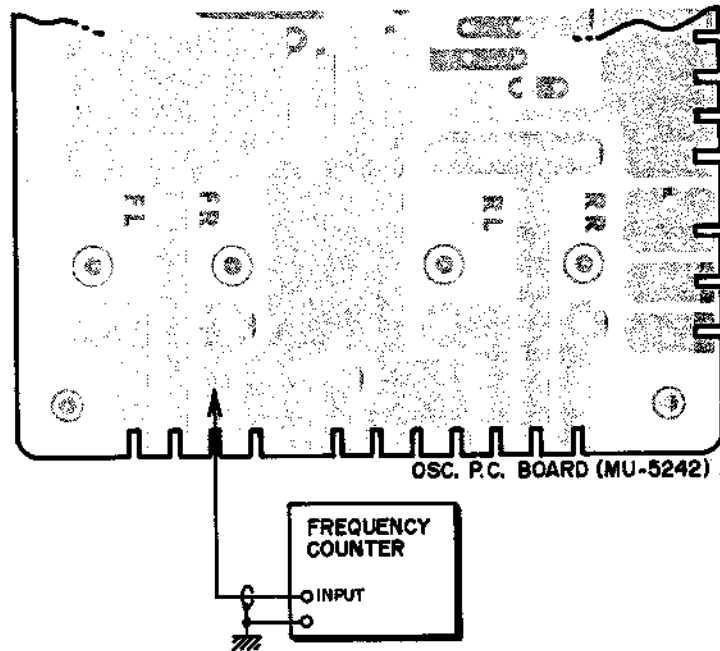

Fig. 21

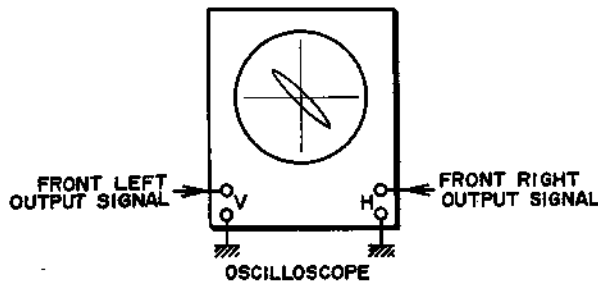

Fig. 22

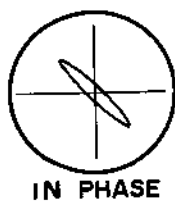

Fig. 23



Fig. 24

Connect the various measuring instruments as shown in Fig. 20.

1. PLAYBACK LEVEL ADJUSTMENT

- 1) Set Tape Speed Selector to 7-1/2 ips.
- 2) Set Stereo Selector to 4-CH.
- 3) Playback a 250 Hz 7-1/2 ips. recorded test tape.
- 4) Adjust Playback Amp. P.C. Board semi-fixed resistor VR1 50 kB shown in Fig. 19 to obtain a 4 dB(1.228V) high sensitivity V.T.V.M. output level indication on each channel.

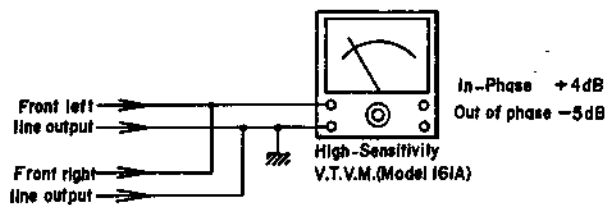

Fig. 25

- VR1 F.L.: FRONT LEFT CHANNEL
- VR1 F.R.: FRONT RIGHT CHANNEL
- VR1 R.L.: REAR LEFT CHANNEL
- VR1 R.R.: REAR RIGHT CHANNEL

2. RECORDING LEVEL ADJUSTMENT

- 1) Set Tape Speed Selector to 7-1/2 ips.
- 2) Set Stereo Selector to 4-CH.
- 3) Set all 4 Recording Level Controls VR1 through VR4 50 kA (F.L., F.R., R.L., and R.R.) to maximum (fully clockwise) and load a blank tape.
- 4) Set tape deck to recording mode and supply a 1,000 Hz sine wave signal to the line input from the audio frequency oscillator.
- 5) Adjust the attenuator to obtain a 4 dB(1.228V) high sensitivity V.T.V.M. output level indication on all 4 channels.
- 6) Under the condition described above, record a 1,000 Hz 4 dB signal for a few seconds on the blank tape, and playback this recording.
- 7) Adjust Recording Amp. P.C. Board semi-fixed resistor VR1 5 kA shown in Fig. 19 so that at playback time, the high sensitivity V.T.V.M. line output level indication is 4 dB(1.228V) on each channel.

VR1 F.L.: FRONT LEFT CHANNEL
VR1 F.R.: FRONT RIGHT CHANNEL
VR1 R.L.: REAR LEFT CHANNEL
VR1 R.R.: REAR RIGHT CHANNEL

3. BIAS LEAK ADJUSTMENT

- 1) Following recording level adjustment, remove the line input and set tape deck to recording mode.
- 2) Switch the high sensitivity V.T.V.M. range to -30 dB range.
- 3) Adjust the core of Playback Amp. P.C. Board Coil L1 22 mH to obtain minimum high sensitivity V.T.V.M. indication on each channel.
- 4) Bias leak must be less than -26 dB at 4-CH, and less than -16 dB at 2-CH.

4. FREQUENCY RESPONSE ADJUSTMENT

- 1) Set Tape Speed Selector to 7-1/2 ips.
- 2) Set Stereo Selector to 4-CH.
- 3) Set Tape Selector to NORMAL.
- 4) Turn all Recording Level Controls (VR1 through VR4, 50 kA) to maximum (fully clockwise) and load a blank tape.
- 5) Set tape deck to recording mode and supply a 1,000 Hz sine wave to the line input from Audio Frequency Oscillator and adjust the attenuator to obtain a -16 dB(120 mV) high sensitivity V.T.V.M. line output level indication on all 4 channels.
- 6) Switch the oscillation frequency of the Audio Frequency Oscillator from the condition described in Items 4-5) above to 10,000 Hz.

- 7) Adjust OSC. P.C. Board Trimmer Condensers TC1 through TC4 shown in Fig. 19 to obtain the same V.T.V.M. level indication on all channels at both the 1,000 Hz and 10,000 Hz frequencies.

TC1: FRONT LEFT CHANNEL
TC2: FRONT RIGHT CHANNEL
TC3: REAR LEFT CHANNEL
TC4: REAR RIGHT CHANNEL

5. RECORDING BIAS FREQUENCY MEASURING METHOD

As shown in Fig. 21, connect a Frequency Counter to the output side of the trimmer condenser. Set tape deck to recording mode and take a frequency counter reading. Specified recording bias frequency is 82 ± 5 kHz.

6. 4-CHANNEL PHASE CHECK

CHECK A

- 1) Connect front left signal and front right signal line outputs to the vertical and horizontal input of an Oscilloscope. (See Fig. 22)
- 2) Playback a 250 Hz 7-1/2 ips. pre-recorded test tape.
- 3) If front left signal and front right signal is in phase, the waveform on oscilloscope screen will appear as shown in Fig. 23.
- 4) If front left signal and front right signal is out of phase (180° phase inverted), the waveform on oscilloscope screen will appear as shown in Fig. 24.
- 5) Make the same phase check on front left/rear left and rear left/rear right signals.
- 6) In case out of phase signals exist, head connection is reversed or playback head adjustment is necessary.

CHECK B

- 1) Playback a 250 Hz 7-1/2 ips. pre-recorded test tape.
- 2) Connect front left signal and front right signal line outputs in parallel and connect to the inputs of a high sensitivity V.T.V.M. (See fig. 25)
- 3) If front left signal and front right signal is in phase, the high sensitivity V.T.V.M. indication will be about 4 dB.
- 4) If front left signal and front right signal is out of phase (180° phase inverted), the high sensitivity V.T.V.M. indication will be about -5 dB.
- 5) Make the same phase check on front left/rear left and rear left/rear right signals.

VIII. D. C. RESISTANCE OF VARIOUS COILS

D.C. Resistance shown in chart are average values.

Parts	Designation	D.C. Resistance
CAPSTAN MOTOR	HM-12-16MC	Between PNK-RED 130Ω Between PNK-BRN 180Ω Between GRN-GRY 360Ω Between GRN-YLW 370Ω
REEL MOTOR	24XO-MR	Between RED-BLU 74Ω Between GRN-YLW 166Ω
REVERSE SOLENOID	0730 THTI3	290Ω
REVERSE RELAY	MY4-O-US-AD4 DC24V	650Ω
HEADPHONE OUTPUT TRANSFORMER	N19-5921S	Primary 230Ω Secondary 0.9Ω
OSCILLATOR COIL	OT-204	Between 1-3 0.3Ω Between 4-6 0.7Ω Between 7-9 8.2Ω
FULL TRACK ERASE HEAD	EF-210	2.8Ω
4 TRACK ERASE HEAD	E4-260	1.6Ω
4 TRACK RECORDING/PLAYBACK HEAD	P4-50	160Ω

Chart 2

IX. COMPOSITE VIEWS OF COMPONENTS

1. SYSTEM CONTROL P.C. BOARD MU-1202

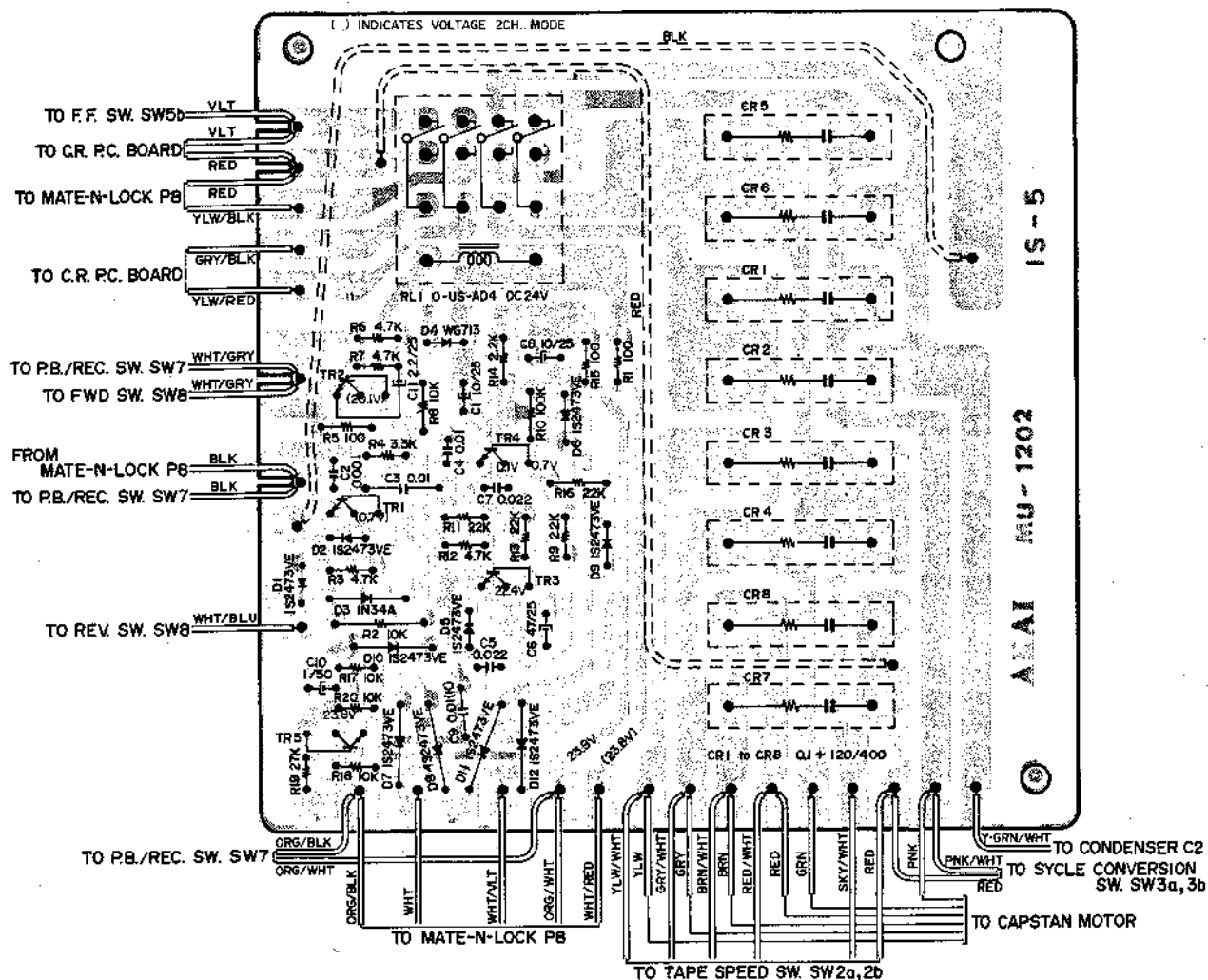

2. CR P.C. BOARD MU-1007

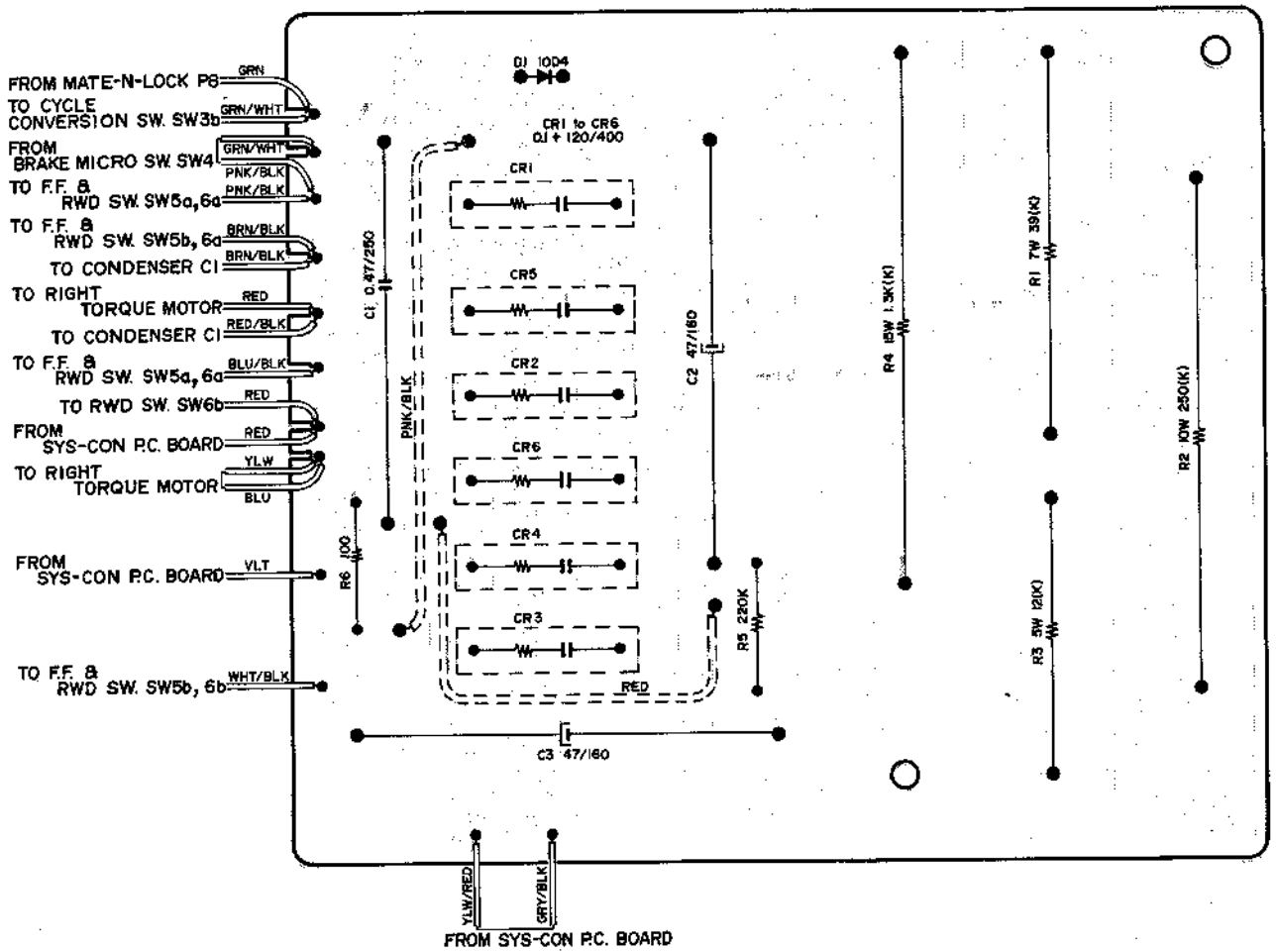

3. PB. AMP. P.C. BOARD MU-5239

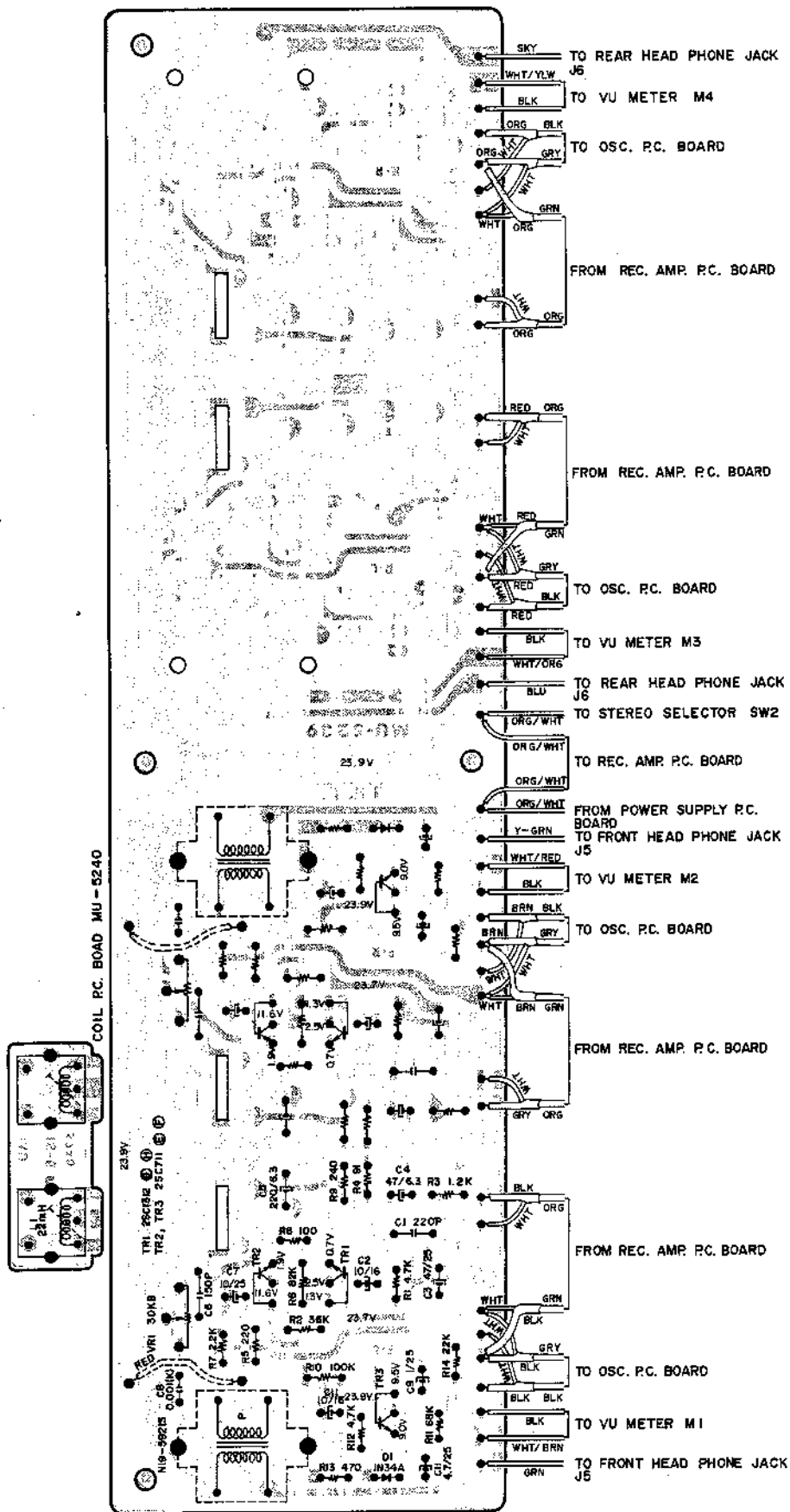

4. REC. AMP. P.C. BOARD MU-5238 (FRONT)

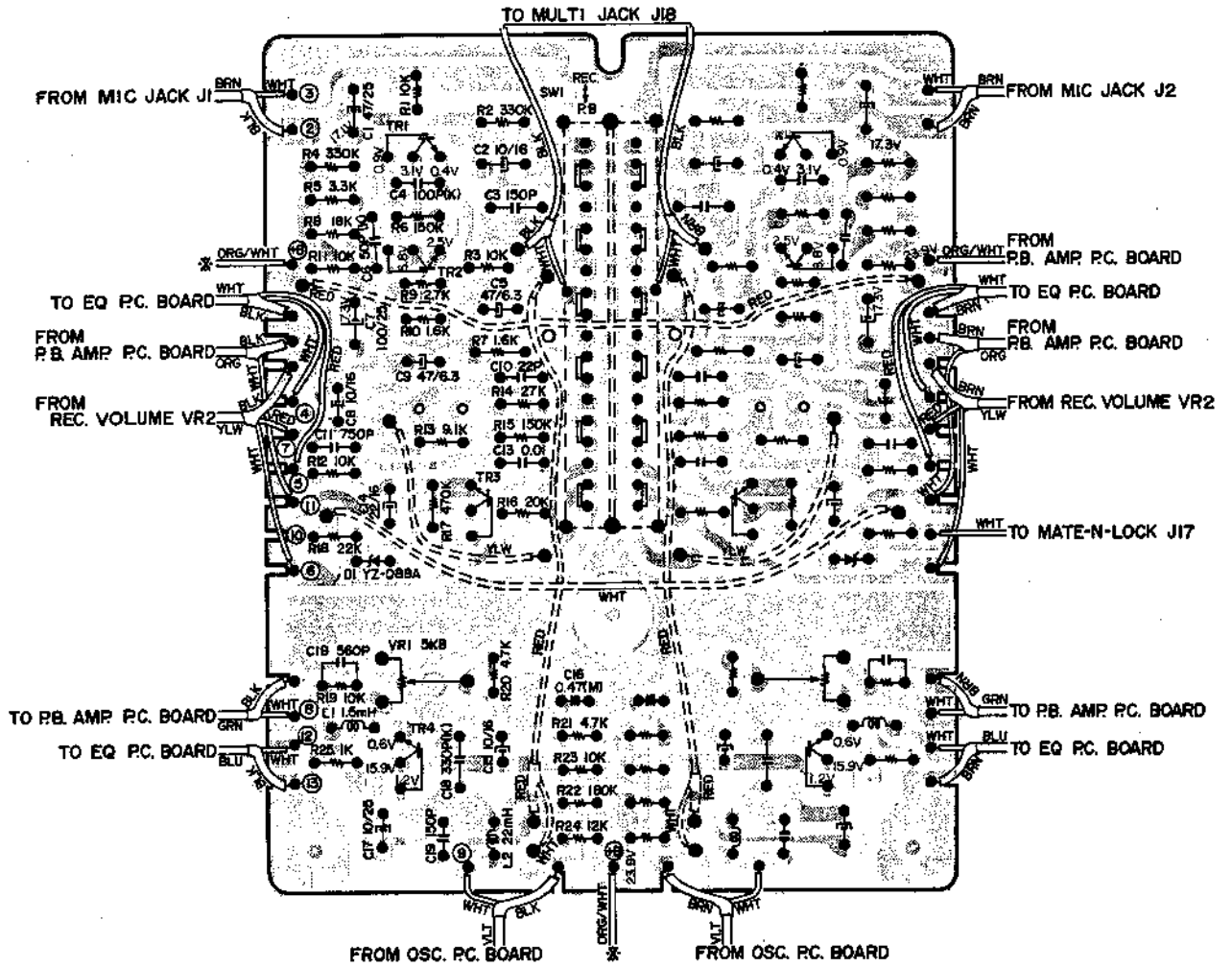

5. REC. AMP. P.C. BOARD MU-5238 (REAR)

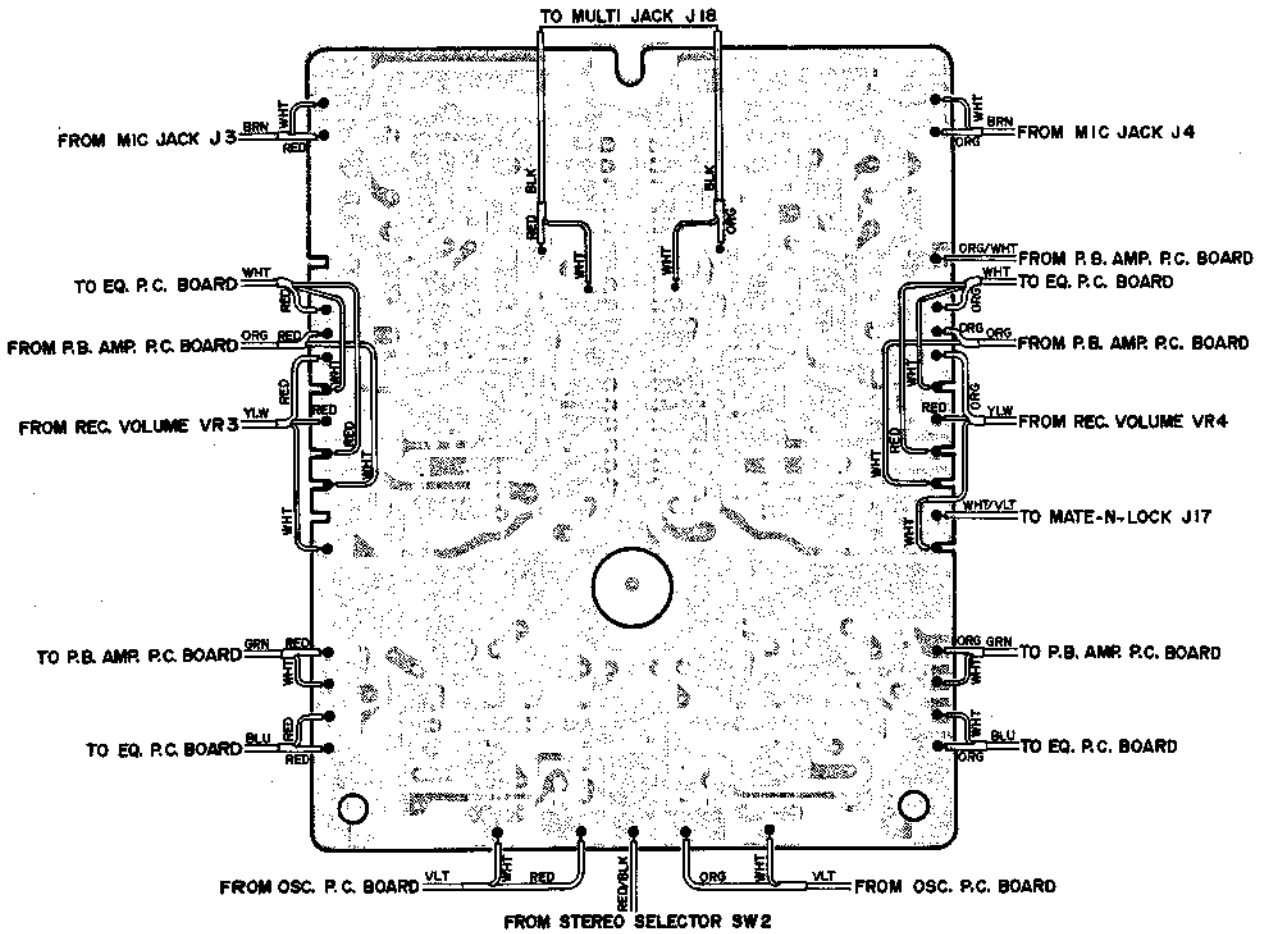

6. EQ. P.C. BOARD MU-5241

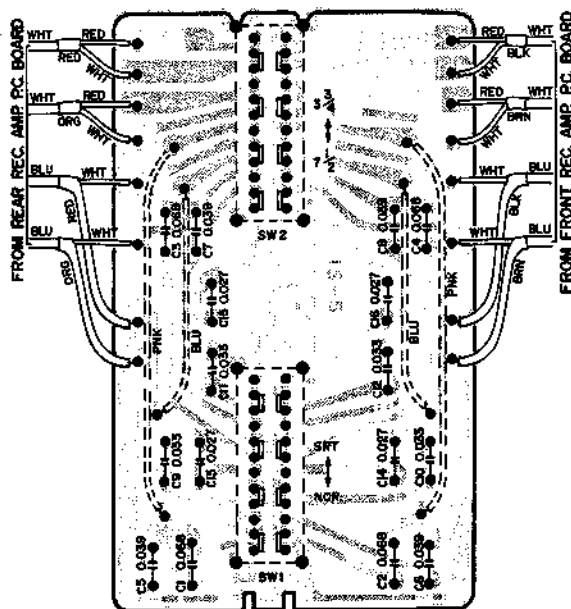

7. OSC. P.C. BOARD MU-5242

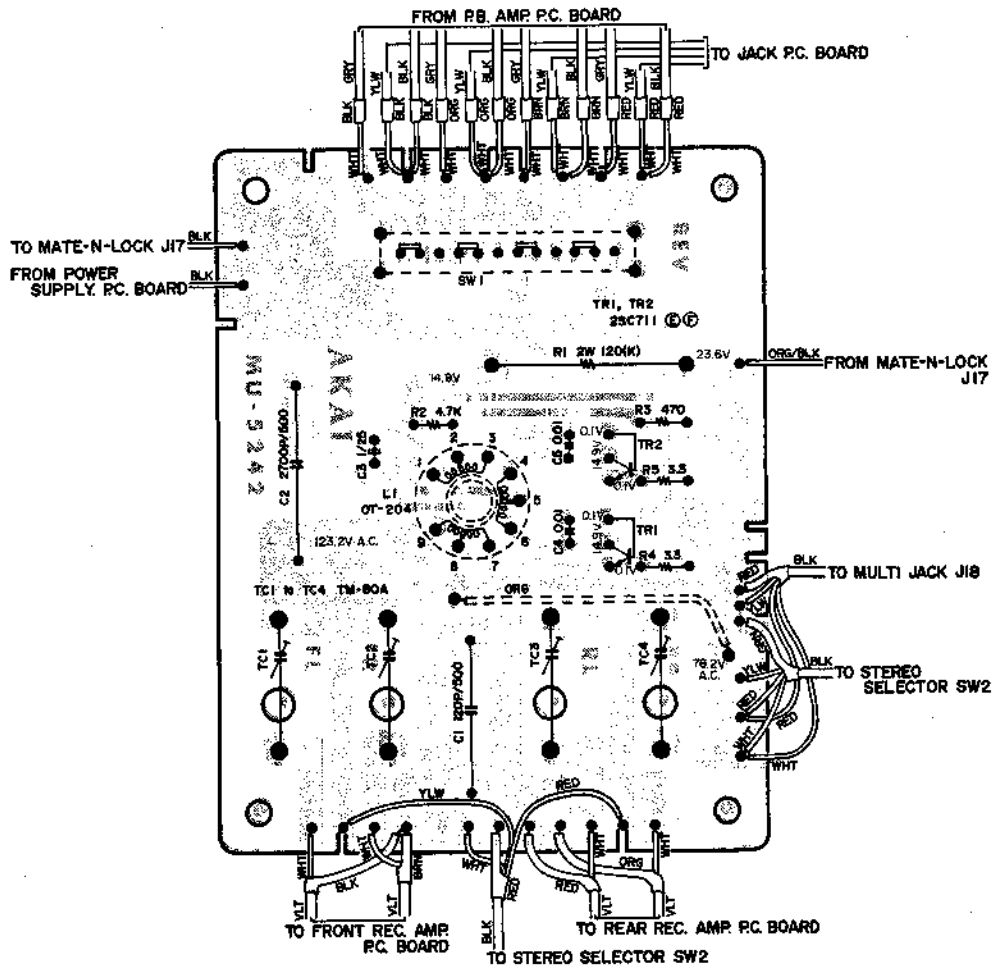

8. POWER SUPPLY P.C. BOARD MU-5017

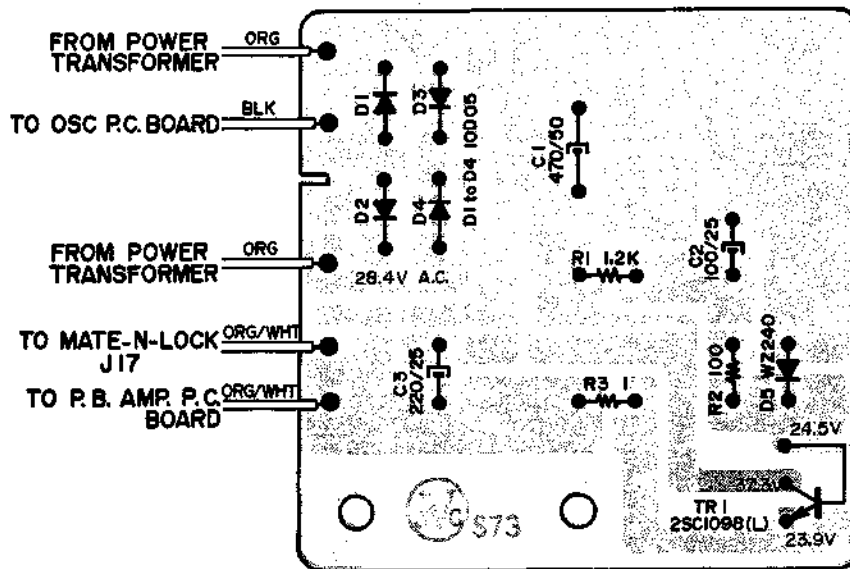

9. JACK P.C. BOARD MU-5237

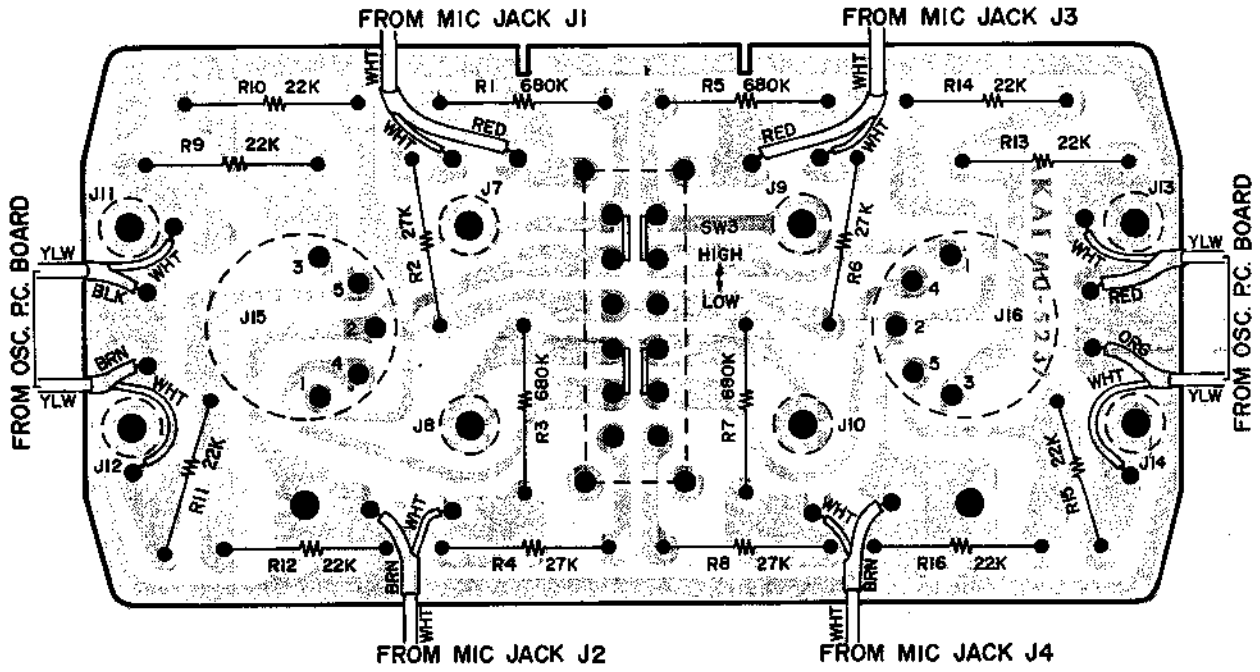

SECTION 2

PARTS LIST

TABLE OF CONTENTS

FIG. 1	HEAD BLOCK	36
FIG. 2	REEL MOTOR & REEL TABLE BLOCK	38
FIG. 3	MAIN MOTOR BLOCK	40
FIG. 4	FLYWHEEL BLOCK	42
FIG. 5	SWITCH BLOCK	44
FIG. 6	MECHANISM ASSEMBLY BLOCK	45
FIG. 7	SYSTEM CONTROL P.C. BOARD (MU-1202) BLOCK	48
FIG. 8	CR P.C. BOARD (MU-1007) BLOCK	49
FIG. 9	REC. AMP. P.C. BOARD (MU-5238) BLOCK	50
FIG. 10	P.B. AMP. P.C. BOARD (MU-5239) BLOCK	51
FIG. 11	EQ. P.C. BOARD (MU-5241) BLOCK	52
FIG. 12	OSC. P.C. BOARD (MU-5242) BLOCK	52
FIG. 13	POWER SUPPLY P.C. BOARD (MU-5017) BLOCK ...	53
FIG. 14	AMPLIFIER ASSEMBLY BLOCK	54
FIG. 15	FINAL ASSEMBLY BLOCK	57
INDEX		58

HOW TO USE THIS PARTS LIST

1. This parts list is compiled by various individual blocks based on assembly process.
2. When ordering parts, please describe parts number, serial number, and model number in detail.
3. How to read list.

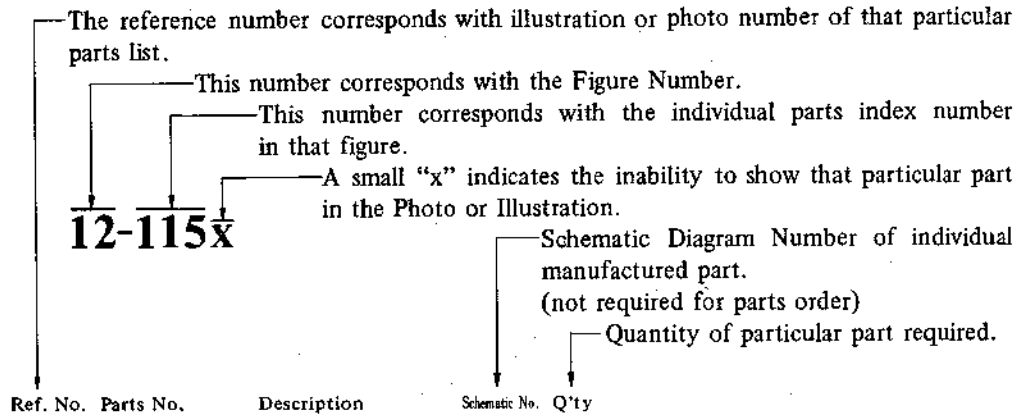

4. The symbol numbers shown on the P.C. Board list can be matched with the Composite Views of components of the Schematic Diagram or Service Manual.
5. The indications of Resistors and Capacitors in the photos of P.C. Board are being eliminated.
6. The shape of the parts and parts name, etc. can be confirmed by comparing them with the parts shown on the Electrical Parts Table of P.C. Board.
7. Both the kind of part and installation position can be determined by the Parts Number. To determine where a parts number is listed, utilize Parts Index at end of Parts List.
It is necessary first of all to find the Parts Number. This can be accomplished by using the Reference Number listed at right of parts number in the Parts Index. (meaning of ref. no. outlined in Item 3 above).
8. Utilize separate "Price List for Parts" to determine unit price. The most simple method of finding parts Price is to utilize the reference number.

ELECTRICAL PARTS TABLE





<p>Because the indication of resistors and capacitors in the P. C. Board photos are being eliminated, please confirm parts name and shape by comparing them with the parts shown in this table.</p>	<p style="text-align: center;">1</p>  <p style="text-align: center;">Solid Resistor</p>	<p style="text-align: center;">2</p> <p style="text-align: right;">Stopper Type</p>  <p style="text-align: center;">Insulator Type</p> <p style="text-align: center;">Carbon Resistor</p>	<p style="text-align: center;">3</p>  <p style="text-align: center;">Metal Oxide Film Resistor</p>
<p style="text-align: center;">4</p>  <p style="text-align: center;">Cement Resistor</p>	<p style="text-align: center;">5</p>  <p style="text-align: center;">Wire-Wound Resistor</p>	<p style="text-align: center;">6</p>  <p style="text-align: center;">Thermister</p>	<p style="text-align: center;">7</p>  <p style="text-align: center;">Enamel Resistor</p>
<p style="text-align: center;">1</p>  <p style="text-align: center;">MP Capacitor (Tubular Type)</p>	<p style="text-align: center;">2</p>  <p style="text-align: center;">Plastic Capacitor</p>	<p style="text-align: center;">3</p>  <p style="text-align: center;">Mylar Capacitor</p>	<p style="text-align: center;">4</p>  <p style="text-align: center;">VFM (Hi-Q) Capacitor</p>
<p style="text-align: center;">5</p>  <p style="text-align: center;">Mylar Capacitor</p>	<p style="text-align: center;">6</p>  <p style="text-align: center;">Tantalum Capacitor</p>	<p style="text-align: center;">7</p>  <p style="text-align: center;">Oil Capacitor (Tubular Type)</p>	<p style="text-align: center;">8</p> <p style="text-align: right;">Vertical Type</p> <p style="text-align: center;">(Tubular Type)</p>  <p style="text-align: center;">Styrol Capacitor</p>
<p style="text-align: center;">9</p>  <p style="text-align: center;">Electrolytic Capacitor (Tubular Type)</p>	<p style="text-align: center;">10</p> <p style="text-align: right;">Vertical Type</p> <p style="text-align: center;">(Tubular Type)</p>  <p style="text-align: center;">Electrolytic Capacitor</p>	<p style="text-align: center;">11</p>  <p style="text-align: center;">Ceramic Capacitor</p>	<p style="text-align: center;">12</p>  <p style="text-align: center;">Metalized Mylar (Paper) Capacitor</p>
<p style="text-align: center;">13</p>  <p style="text-align: center;">Trimmer Condenser</p>		<p style="text-align: center;">VR</p>  <p style="text-align: center;">Semi-Fixed Volume</p>	
<p style="text-align: center;">L</p>  <p style="text-align: center;">Ferri Inductor</p>	<p style="text-align: center;">TR</p>  <p style="text-align: center;">Transistor</p>		
<p style="text-align: center;">CR</p>  <p style="text-align: center;">Spark Quencher</p>	<p style="text-align: center;">D</p>  <p style="text-align: center;">Diode (Silicon, Zener, Germanium)</p>		

FIG. 1 ILLUSTRATION OF HEAD BLOCK



HEAD BLOCK

Ref. No.	Parts No.	Description	Schematic No.	Q'ty
1-1x	BH563545	Head Block Comp.	MU-2	1
1-2	HZ548717	Head Base	MU-0201	1
1-3	HZ548291	Head Base Support	MU-0202	1
1-4	ZS413155	Screw, binding head 3x6		4
1-5	HZ274162	Tape Guide #1	4TR-5	1
1-6x	ZW273802	Toothed Lock Washer M3		2
1-7	ZW273756	Nut M3		2
1-8	HZ317597	Tape Guide A, MR	MR-4	2
1-9x	ZS200384	Screw, countersunk head 3x6		1
1-10	HZ541170	Panel Support	MC-0209	1
1-11	HZ410984	Erase Head Base	LF-0002	2
1-12	HE552914	ERASE HEAD EF-210		1
1-13	ZS201475	Screw, pan head 2x3		4
1-14	ZS403301	Screw, binding head 3x6, w/washer		5
1-15	HE563220	ERASE HEAD E4-260		1
1-16	ZW273778	Earth Lug M3		3
1-17	HA445116	P.B. Head Angle	DF-0002	1
1-18	HP412165	P.B. HEAD P4-50		1
1-19	HZ411085	4QP Shield Case	LF-0014	1
1-20x	HZ411074	4QP Back-shield	LF-0013	1
1-21	HZ411017	Head Shield Case	LF-0005	1
1-22	ZS201508	Screw, pan head 2x4		2
1-23x	EZ437736	Head Terminal Plate (LF)	LF-0028	1
1-24	ZG396538	Cone Spring	KD-0010	3
1-25	ZS345914	Screw, round head 3x10		1
1-26	ZS455231	Screw, countersunk head 3x10		2
1-27x	EA222096	Connector P.C. Board	RD-140	1
1-28x	HZ411030	Wire Fitting Metal	LF-0007	1
1-29	HZ541181	Sensing Post B	MC-0210	1
1-30	HZ317632	Insulator Collar A	MR-36	4
1-31	HZ318047	Sensing Collar A	MR-35	1
1-32	HZ318036	Tension Arm, w/pulley	MR-37	1
1-33	ZW316800	Earth Lug M2.6		1
1-34	ZS554962	Screw, pan head 2.3x25		1
1-35	HZ467010	Cushion Rubber, MC	MC-0004	1
1-36	ZG317114	Tension Lever Spring	MR-39	1
1-37	ZW364803	Washer (Nylon)D5.1x10.3x0.1t		1
1-38	ZW270123	'E' Ring 4M	6-1-9	2
1-39	HZ547751	Tape Guide Table A, w/shaft	MU-0015	1
1-40	ZW231805	Tape Guide Washer (large)	3A-356	2
1-41	MV248117	Bearing 635AHZ ZMC1ERB32		1
1-42	ZW326463	Washer (PBP)D5.1x10.3x0.2t		1
1-43	HZ317092	Tape Guide Table B	MR-32	1
1-44	ZS414033	Screw, countersunk head 3x8		3
1-45	HZ455962	Sensing Collar B	MC-1019	1
1-46	HZ455973	Sensing Collar A	MC-1018	1
1-47	ZS554916	Screw, binding head 2.3x20		1
1-48	ZS558134	Screw, countersunk head 2.3x5		1
MECH. ASSEMBLY BLOCK				
1-49	ML544285	DS. Table	MU-0011	1
1-50	MZ316822	Insulator Collar B	MR-225	2
1-51	HZ542092	Insulator Washer (Mylar)	MC-0213	2
1-52	ZW563218	Washer (Bake)D3.2x10x1t		2
1-53	ZW316800	Earth Lug M2.6		2
1-54	ZS464692	Screw, binding head 2.3x6		2
1-55	ZW273688	Nut M2.3		2
1-56	HL541168	DS. Lever A	MC-0208A	1
1-57	HL542687	DS. Lever B	MC-0208B	1
1-58	HL541157	DS. Lever Support	MC-0207	1
1-59	ZS417137	Screw, binding head 3x4		2
1-60	ZG317777	Pull Spring	MR-47	2
1-61	ZS558101	Screw, pan head 3x6, w/washer		2

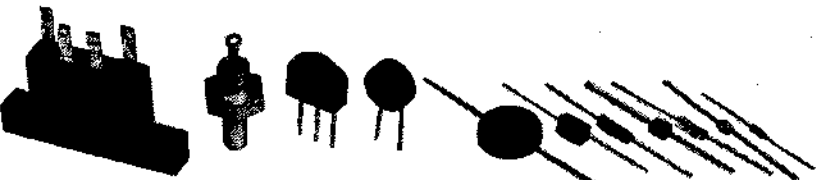
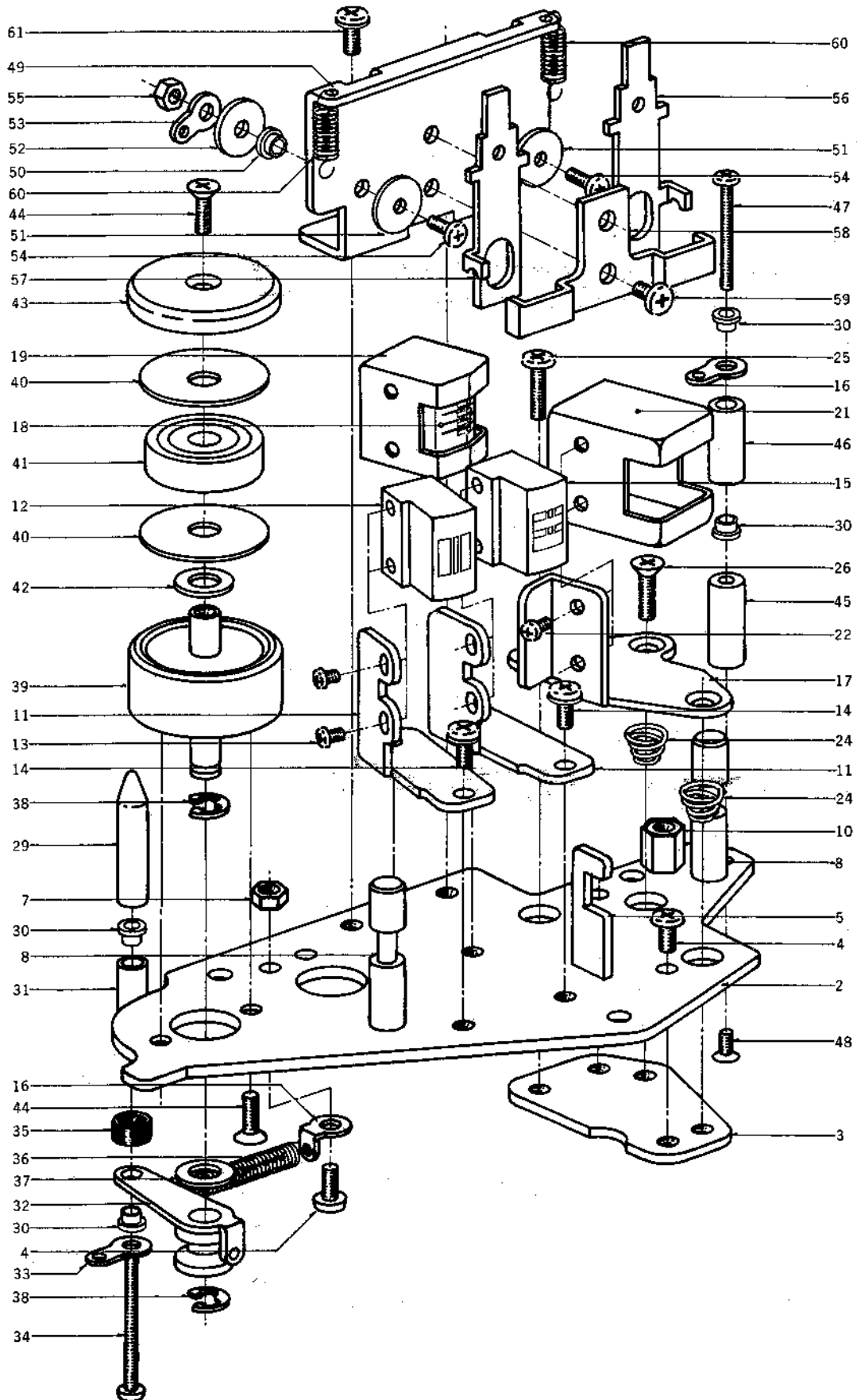
FIG. 2 ILLUSTRATION OF REEL MOTOR & REEL TABLE BLOCK

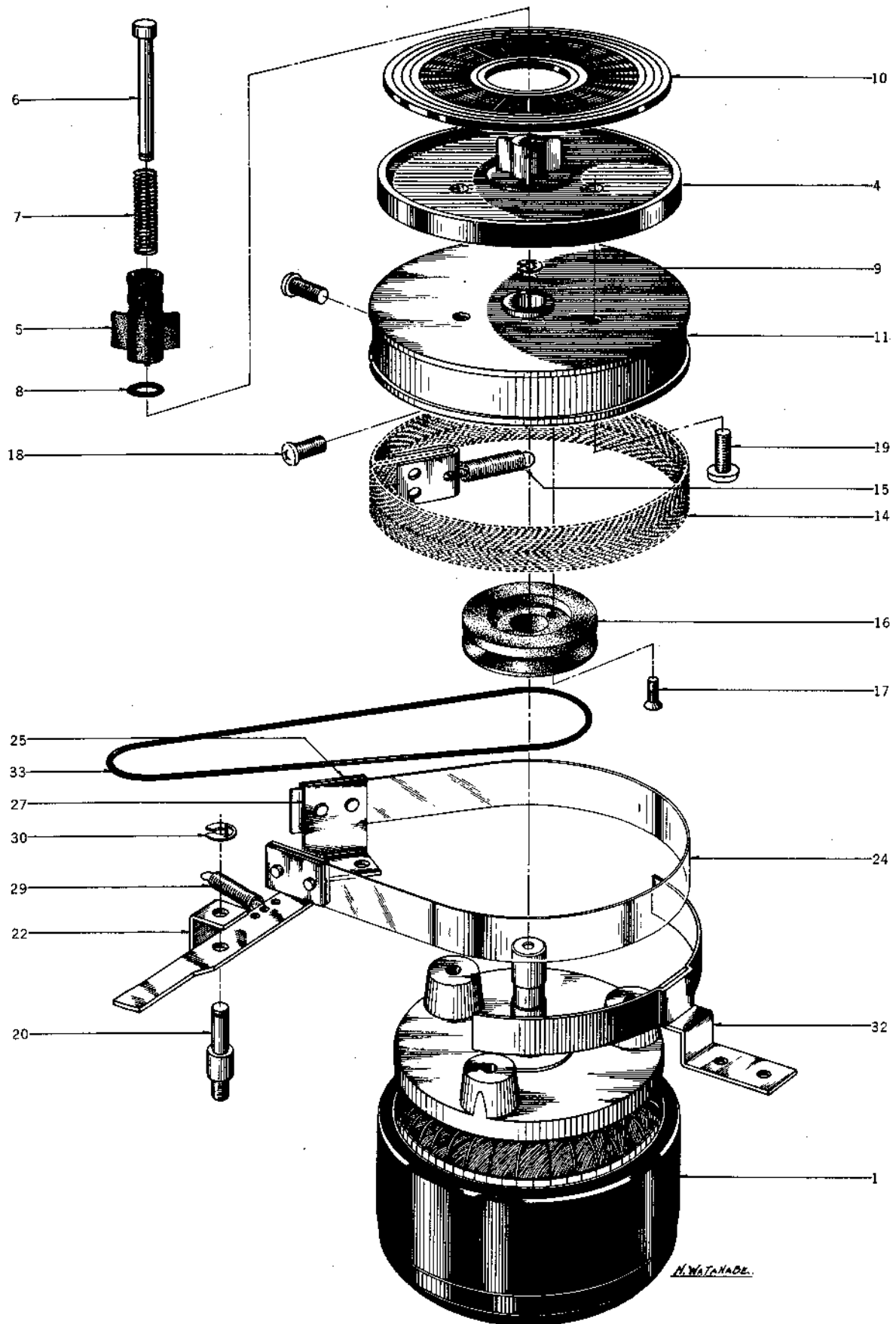

REEL MOTOR & REEL TABLE BLOCK

Ref. No.	Parts No.	Description	Schematic No.	Q'ty
2-1	BM314741	Reel Motor Block (24X0-2)	MC, MS, MR, KD	1
		Comp.		
2-2x	BR317395	Supply Reel Table Comp.	MU, MC, MR	1
2-3x	BR317384	Take-up Reel Table Comp.	MU, MR	1
2-4	MT317441	Reel Table, MR	MR-215	1
2-5	MT255420	Reel Retainer	3R-102	1
2-6	MS342000	Reel Shaft	3R-108	1
2-7	ZG255633	Reel Spring	3R-109	1
2-8	MT297663	3R 'O' Ring 2.9x1.65M	3R-139	1
2-9	ZW270088	'E' Ring 1.9M	6-1-9	1
2-10	MT317463	Reel Table Rubber, MR	MR-250	1
2-11	MT317452	Brake Drum (R) (Take-up)	MR-216	1
2-12x	MT325473	Brake Drum (L) (Supply)	MR-216	1
2-13x	ZW273778	Earth Lug M3		1
2-14	MT436860	Brake Cloth Comp.	MR-269	1
2-15	ZG317496	Felt Tension Spring	MR-260	1
2-16	MR317507	Counter Pulley (Take-up)	MR-217	1
2-17	ZS365973	Screw, countersunk head		
		2.3x12		2
2-18	ZS424056	Screw, pan head 4x10		2
2-19	ZS413785	Screw, binding head 3x12		3

MECH. ASSEMBLY BLOCK

2-20	MH317373	Brake Lever Prop	MR-102	2
2-21x	ZW416698	Nut M4		2
2-22	ML314976	Brake Lever A (Take-up)	MR-210	1
2-23x	ML396810	Brake Lever B (Supply)	KD-1038	1
2-24	MT314987	Brake Band	MR-213	2
2-25	MZ314998	Brake Band Retaining Plate	MR-212	4
2-26x	ZS417137	Screw, binding head 3x4		6
2-27	MZ315000	Brake Band Support	MR-214	2
2-28x	ZS425981	Screw, binding head 3x3		2
2-29	ZG315011	Brake Lever Spring	MR-116	2
2-30	ZW290283	'U' Ring 2.85M	6-1-1	2
2-31x	ZS323728	Screw, binding head 3x5		8
2-32	MZ317406	Brake Band Guide, w/base	MR-120	2
2-33	MB527556	Counter Belt D93x1.5	ND-1022	1

FIG. 3 ILLUSTRATION OF MAIN MOTOR BLOCK

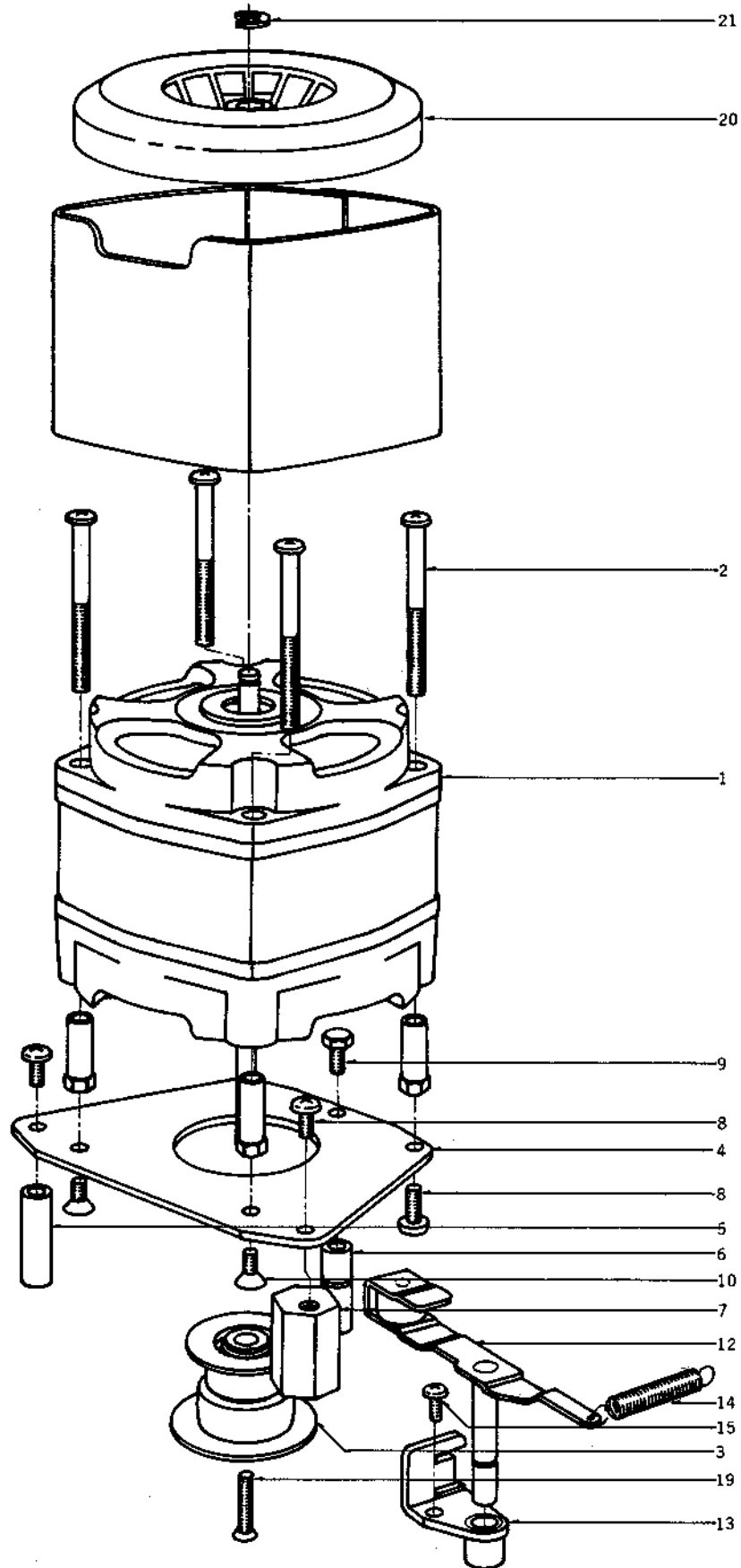

MAIN MOTOR BLOCK

Ref. No.	Parts No.	Description	Schematic No.	Q'ty
MAIN MOTOR BLOCK				
3-1	BM563196	Main Motor Block (HM2-16MU) Comp.	MU	1
3-2	ZS427037	Screw, pan head 4x50, w/washer		4
3-3	MR540876	Motor Pulley Comp.	MC-7201	1
3-4	MZ316293	Motor Mt. Plate, MR	MR-717	1
3-5	MH254160	Motor Prop A	24X-730	1
3-6	MZ254182	Motor Prop B	24X-731	1
3-7	MH316304	Motor Prop, MR	MR-706	1
3-8	ZS424056	Screw, pan head 4x10		4
3-9	ZS272395	Motor Prop Retaining Screw, M-7	24X-732	1
3-10	ZS427026	Screw, countersunk head 4x10		2
BELT CHANGE LEVER BLOCK				
3-11x	BL555344	Belt Change Lever Block Comp.	MU, MC-2	1
3-12	ML540990	Belt Change Lever, w/roller	MC-1207	1
3-13	ML541001	Belt Change Lever Stopper, w/metal	MC-1208	1
3-14	ZG217337	Belt Return Spring	4TR-224	1
3-15	ZS417150	Screw, pan head 4x6		1
3-16x	ZG217394	Belt Change Spring B	MH-125	1
3-17x	ZW260054	Washer (SUP)D6.1x10x0.25t		1
3-18x	ZW290283	'U' Ring 2.85M	6-1-1	1
3-19	ZS203016	Screw, oval countersunk head 3x15		1
3-20	SZ529108	Main Motor Fan	ND-7010	1
3-21	ZW270134	'E' Ring 5M	6-1-9	1

FIG. 4 ILLUSTRATION OF FLYWHEEL BLOCK

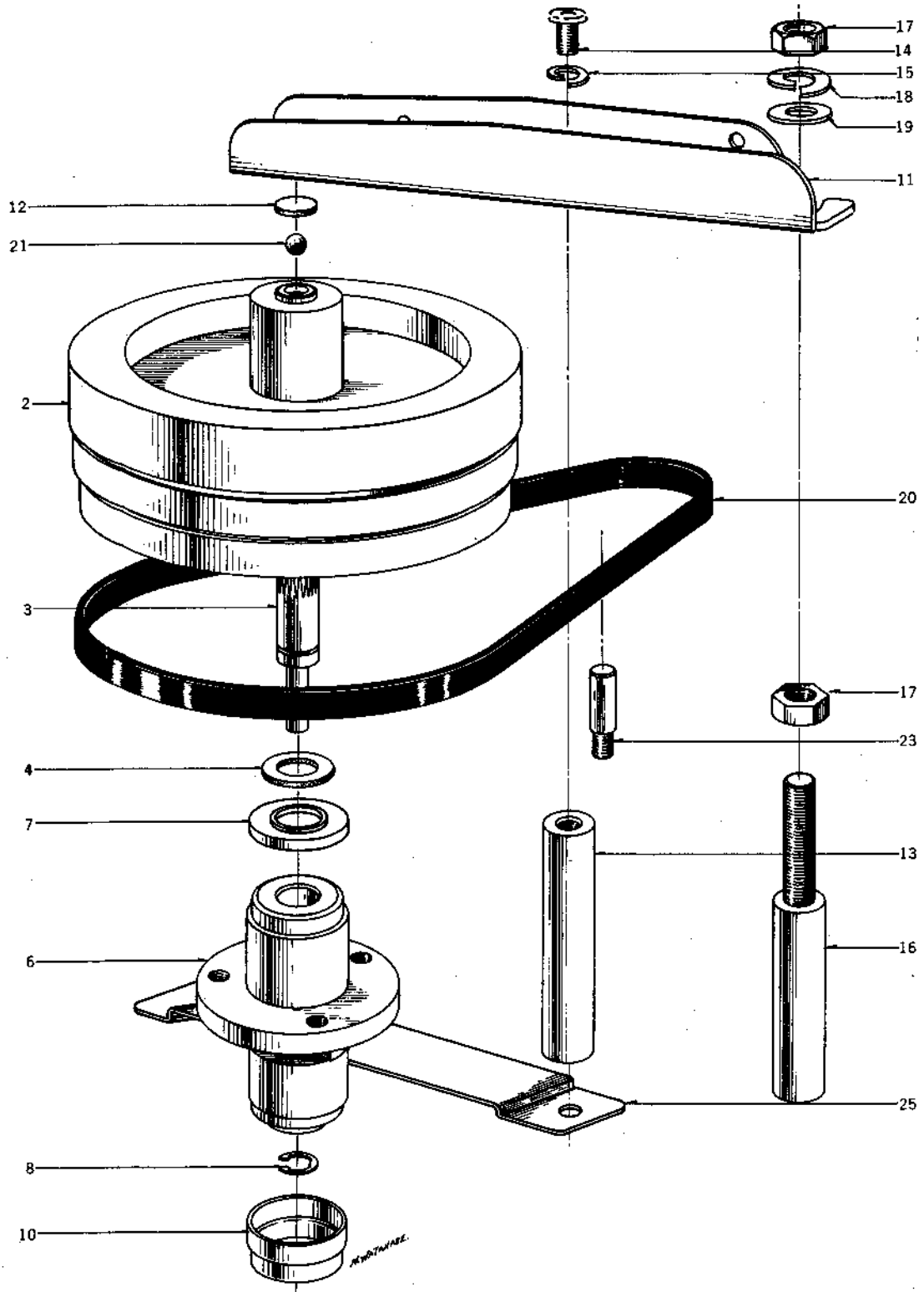

FLYWHEEL BLOCK

Ref. No.	Parts No.	Description	Schematic No.	Q'ty
4-1x	BF476550	Flywheel Block Comp.	MS-2,3, MR-2	1
4-2	MI296245	Flywheel 24	MH-202	1
4-3	MS476572	Main Shaft, D6	MR-2005	1
4-4	ZW447208	Flywheel Thrust B		
		D7.9x1.3x0.5t	101025	1
4-5x	ZS373577	Set Screw, hexagon socket		
		5x6(flat)		2
4-6	MZ296256	Main Case A 24, w/metal	MH-206	1
4-7	MZ446635	Thrust Cap, Main Metal B2	LF-2006	1
4-8	MH244710	Flywheel Fixing Pin	90-250	1
4-9x	MZ244113	Felt D12.5x16x2t		1
4-10	MZ253113	Main Metal Cap B	MH-208	1

MECH. ASSEMBLY BLOCK

4-11	MZ314897	Flywheel Support Plate, MR	MR-121	1
4-12	ZW392681	Washer (Nylon)D8x1t (without hole)		1
4-13	MH273036	Flywheel Prop A, M-9	M9-310	1
4-14	ZS413201	Screw, pan head 4x8		1
4-15	ZW273914	Spring Washer M4		3
4-16	MH273047	Flywheel Prop B, M-9	M9-311	1
4-17	ZW413280	Inch Nut 1/4" mountain 20		2
4-18	ZW393232	Spring Washer 1/4"		1
4-19	ZW413998	Washer (SUP)D6.8x12.7x1t		1
4-20	MB541012	Drive Belt (flat) D116.9x1.6x7	MC-1209	1
4-21	MV269965	Steel Ball D4		1
4-22x	ZS424056	Screw, pan head 4x10		2
4-23	MH248343	Belt Guide Pin	4TR-109	1
4-24x	ZW416698	Nut M4		1
4-25	MZ439525	Flywheel Belt Holding Plate B	MS-1014	1
4-26x	ZS439514	Screw, binding head 3x18		1
4-27x	ZW273756	Nut M3		1

FIG. 5 ILLUSTRATION OF SWITCH BLOCK

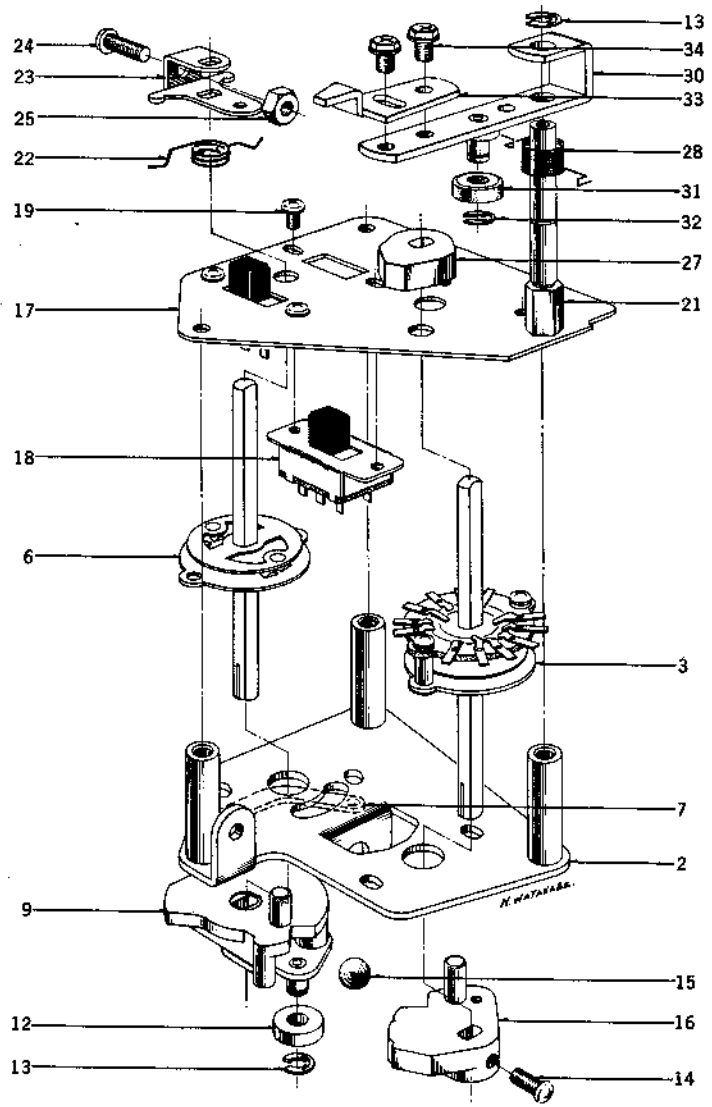

SWITCH BLOCK

Ref. No.	Parts No.	Description	Schematic No.	Q'ty	Ref. No.	Parts No.	Description	Schematic No.	Q'ty
SWITCH BLOCK									
5-1x	BS558336	Switch Block Comp.	MU-1, 2	1	5-21	MH317046	Rec. Lever Prop	MR-206	1
5-2	HZ402390	SW. Table A-2, MR (w/prop)	MR-201	1	5-22	ZG225516	SW. Spring	MR-255	1
5-3	ES316923	Play Shaft (Y type) Y-133	25-8-6	1	5-23	MZ317024	SW. Cam	MR-204	1
5-4x	ZW273802	Toothed Lock Washer M3		2	5-24	ZS424056	Screw, pan bead 4x10		1
5-5x	ZW273756	Nut M3		2	5-25	ZW416698	Nut M4		1
5-6	ES316934	Rewind Shaft (Y type)	25-8-5	1	5-26x	ZS323728	Screw, binding head 3x5		3
5-7	MZ316945	Nut Plate	MR-245	1	5-27	MZ317068	Amp. SW. Cam B	MR-243	1
5-8x	ZS413728	Screw, binding head 3x6, w/washer		2	5-28	ZG227564	Spring H	900-120	1
5-9	MZ316956	Cam A-3	MR-242	1	SWITCH LEVER BLOCK				
5-10x	ZW259942	Washer (Fiber)D5.1x10.3x0.5t		1	5-29x	BL204480	Switch Lever Block Comp.	#2-MR	1
5-11x	ZW376402	Washer (Fiber)D5.1x10.3x1t		2	5-30	ML226080	SW. Lever A, w/shaft B	900-255	1
5-12	MR269730	Cam Roller D $\frac{1}{2}$	900-213	1	5-31	MR217203	Cam Roller A (Nylon)D12	900-153	1
5-13	ZW290283	'U' Ring 2.85M	6-1-1	2	5-32	ZW290283	'U' Ring 2.85M	6-1-1	1
5-14	ZS413201	Screw, pan head 4x8		3	5-33	ML226124	SW. Lever B	900-256	1
5-15	MV270066	Steel Ball D8		1	5-34	ZS437545	Hexagon Bolt 4x7, w/washer		2
5-16	MZ405483	Cam B-1, w/tap	900-206	1					
5-17	MZ544364	Control Chassis	MU-2001	1	5-35x	MZ256814	Rewind Shaft Spacer	M9-124	2
5-18	ES479485	Slide SW. S-1	25-3-66	2					
5-19	ZS371856	ISO Screw, binding head 3x5		4					
5-20x	ZS559045	Screw, binding head 4x8, w/washer		2					

When ordering parts, please describe Parts Number, Serial Number, and Model Number in detail.

FIG. 6a ILLUSTRATION OF MECHANISM ASSEMBLY BLOCK

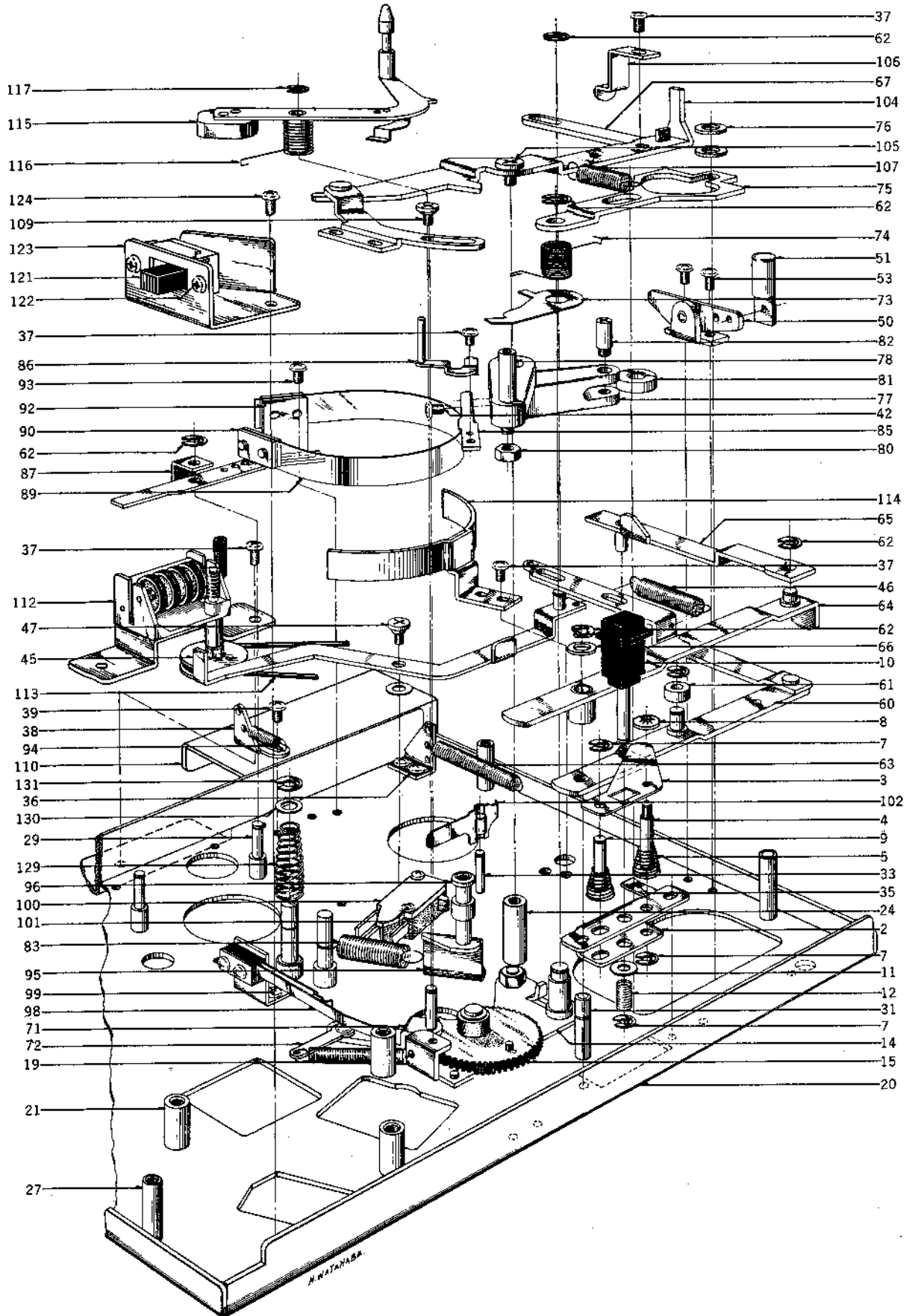
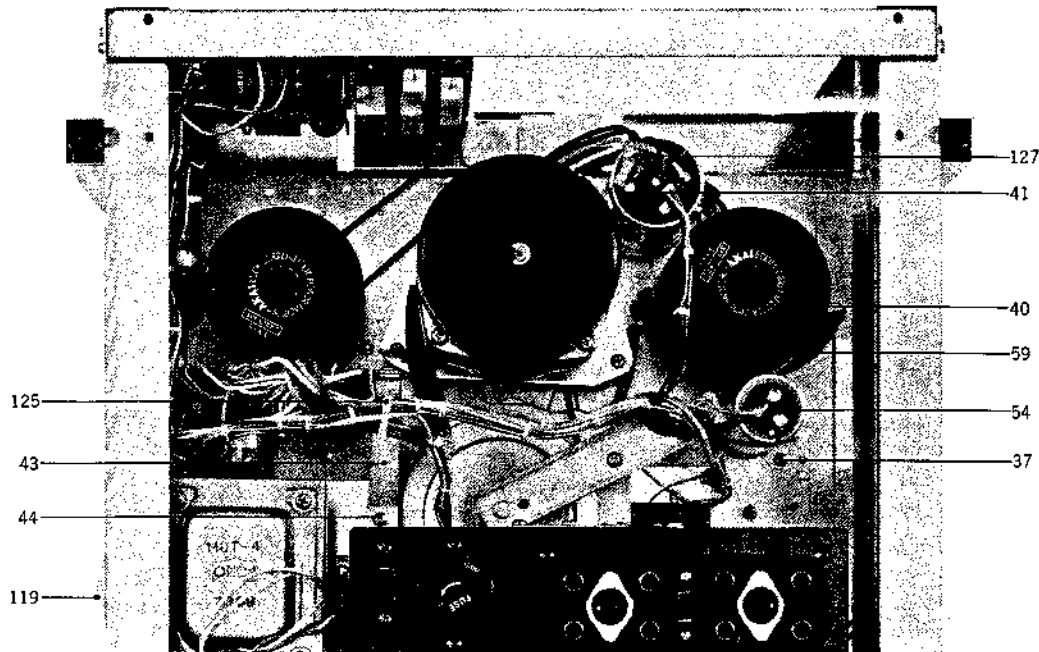

FIG. 6b PHOTO OF MECHANISM ASSEMBLY BLOCK



MECHANISM ASSEMBLY BLOCK

Ref. No.	Parts No.	Description	Schematic No.	Q'ty	Ref. No.	Parts No.	Description	Schematic No.	Q'ty
REC. BUTTON BLOCK									
6-1x	BZ558347	Rec. Button Block Comp.	MU-1, 2	1	6-38	MZ314605	Spring Rack, MR	MR-104	2
6-2	MZ316708	Stopper Table	MR-219	1	6-39	ZS425981	Screw, binding head 3x3		4
6-3	MZ316710	Cam Stopper	MR-220	1	6-40	ZS413212	Screw, binding head 3x5, w/lug		1
6-4	MS316721	Stopper Shaft	MR-221	1	6-41	EC520626	MP/C. (3+1) μ Fx2 250WVAC (Lug type)	24-9-74	1
6-5	ZG316732	Cone Spring	MR-244	2	6-42	ZS413223	Screw, binding head 3x5, w/washer		6
6-6x	ZW322525	Washer (PBP)D4.1x7x0.2t		1	6-43	MZ544331	P.C. Board Holder B	MU-1004	1
6-7	ZW290283	'U' Ring 2.85M	6-1-1	4	6-44	ZS413155	Screw, binding head 3x6		2
6-8	ZW432944	Push Nut 3x10x0.3t		1	6-45	ML314684	Brake Lever C, w/pin	MR-227	1
6-9	MS316776	Stopper Shaft B	MR-259	1	6-46	ZG314706	Spring IB	MR-115	1
6-10	SK543857	Rec. Button B	MR-222	1	6-47	ZS314717	Graduated Screw, MR	MR-254	1
6-11	ZW419646	Washer (SFC)D4.5x9.8x0.5t		1	6-48x	ZW432347	Washer (Luminar) D6.2x13x0.125t		1
6-12	ZG316765	Rec. Button Spring	MR-252	1	6-49x	ZW273756	Nut M3		1
ECCENTRIC GEAR BLOCK									
6-13x	BZ248027	Eccentric Gear Block Comp.	MC, MS, MR, MR	1	6-50	ML226258	Start Lever A, w/lever B-2	4TR-122	1
6-14	MZ248016	Eccentric Gear Table, w/shaft	4TR-243	1	6-51	SB425777	Start Button D	MS-1002	1
6-15	MZ248005	Eccentric Gear	4TR-245	1	6-52x	ZW314728	Cotter Pin 1.6x8		1
6-16x	ZW861344	Washer (PBP)D6.1x10x0.4t		1	6-53	ZS425788	Screw, round head 3x4		2
6-17x	ZW260144	Washer (Nylon)D6.1x10x0.3t		1	6-54	EC442056	MP/C. 2+1 μ F 250WVAC (Lug type)	24-9-61	1
6-18x	ZW290283	'U' Ring 2.85M	6-1-1	1	6-55x	ZW330412	Adjust Washer (U) D4x13x0.13t		1
6-19	ZG437253	Eccentric Gear Return Spring	MS-202	1	6-56x	ZW330423	Adjust Washer (U) D4x13x0.25t		1
MECH. ASSEMBLY BLOCK									
6-20	MZ317340	MR Mech. Frame, w/pin	MR-101	1	6-57x	ZW330434	Adjust Washer (U) D4x13x0.5t		1
6-21	MH247533	Head Prop E	100012	3	6-58x	ZW330445	Adjust Washer (U) D4x13x0.8t		1
6-22x	ZS413201	Screw, pan head 4x8		2	6-59	MZ314673	Reel Motor Shield	MR-123	1
6-23x	ZS414044	Screw, countersunk head 4x8		1	6-60	ML314763	Lever B, MR (w/lever D)	MR-122	1
6-24	MS317362	Pinch Roller Arm Shaft	MR-125	1	6-61	MR314785	Cam Roller D9	MR-237	1
6-25x	ZW274026	Spring Washer M5		1	6-62	ZW290283	'U' Ring 2.85M	6-1-1	9
6-26x	ZW413278	Nut M5		1	6-63	ZG314818	D Lever Spring	MR-114	1
6-27	MH273295	Mech. Panel Prop, M-9	M9-302	2	6-64	ML334506	Lever A, MR (w/metal)	MR-126	1
6-28x	ZS421806	Screw, pan head 3x8		2	6-65	ML314842	C Lever, MR (w/pin)	MR-108	1
6-29	MH317373	Brake Lever Prop	MR-102	2	6-66	ZW419826	Washer (Fiber)D6.2x10x1t		2
6-30x	ZW416698	Nut M4		2	6-67	ML314864	IB Lever	MR-111	1
6-31	MS260515	A Lever Shaft	900-126	1	6-68x	ZW259705	Washer (BSP)D4.1x13x1t		1
6-32x	ZW413267	Flange Nut M4		1	6-69x	ZS207314	Amp. Lever Set Screw	3A-737	1
6-33	MS250536	Micro Lever Shaft	3A-239	1	6-70x	ZW259885	Washer (PBP)D5.1x10.3x0.1t		1
6-34x	ZW273688	Nut M2.3		1	6-71	MZ260662	AS Lever Prop Base, w/prop	4TR-236	1
6-35	MZ217697	Pause Lever Stopper Plate	M9-113	1	6-72	ZS202116	Screw, binding head 3x5, w/lug		1
6-36	MZ227340	Spring Rack B	900-172	1	6-73	MZ218125	Gear Stopper	4TR-120	1
6-37	ZS323728	Screw, binding head 3x5		21	6-74	ZG226697	Stopper Gear	4TR-121	1
					6-75	ML228868	Auto. Mech. Control Lever	4TR-125	1

When ordering parts, please describe Parts Number, Serial Number, and Model Number in detail.

Ref. No.	Parts No.	Description	Schematic No.	Qty
6-76	ZW260087	Washer (Fiber)D6.1x10x0.5t		1
6-77	ML314932	Pinch Roller Lever, MR	MR-119	1
6-78	MS243404	Pinch Roller Shaft C	4TR-102	1
6-79x	ZW259975	Washer (SUP)D5.1x10.3x0.8t		1
6-80	ZW416698	Nut M4		1
6-81	MR269763	Cam Roller D13	900-154	1
6-82	MS582906	Cam Roller Shaft A-1	7-3-6	1
6-83	ZG455692	Pinch Roller Spring, MS	MS-1015	1
6-84x	ZW314943	Washer (Nylon)D8	MR-113	1
6-85	ML314954	Shifter Lever A	MR-117	1
6-86	ML549213	Shifter Lever B, w/pin	MC-1215	1
6-87	ML314976	Brake Lever A (Take-up)	MR-210	1
6-88x	ML396810	Brake Lever B (Supply)	KD-1038	1
6-89	MT314987	Brake Band	MR-213	2
6-90	MZ314998	Brake Band Retaining Plate	MR-212	4
6-91x	ZS417137	Screw, binding head 3x4		6
6-92	MZ315000	Brake Band Support	MR-214	2
6-93	ZS425981	Screw, binding head 3x3		2
6-94	ZG315011	Brake Lever Spring	MR-116	2
6-95	HZ315077	Reverse Guide Base, w/prop	MR-229	1
6-96	HZ315090	Reverse Guide	RD-225	1
6-97x	ZS344463	Set Screw, hexagon socket 4x6(cup)		1
6-98	ES546794	Tension SW. Comp. MU	MU-1012	1
6-99	ZS427048	Screw, round head 3x3		2
6-100	ES562465	Micro SW. K-1	25-1-26	1
6-101	ZS417148	Screw, binding head 3x15		2
6-102	ML316394	Operation SW. Lever	MR-112	1
6-103x	ZW270088	'E' Ring 1.9M	6-1-9	1
6-104	ML316427	Pause Lever, MR (w/lever B)	MR-233	1
6-105	ZS217877	Pause Lever Set Screw	900-136	1
6-106	MZ316451	Pause Stopper, M-7	MH-126	1
6-107	ZG301061	Pause Spring 990A	4TR-128	1
6-108x	ZW260010	Washer (PBP)D6.1x10x0.1t		1
6-109	ZS207314	Amp. Lever Set Screw	3A-737	1
6-110	MZ548728	Frame Reinforcement Plate	MU-1201	1
6-111x	ZS563332	Tapping Screw #2 4x6(binding)		2
6-112	MC554826	Counter MP-490-19	9-1-28	1
6-113	MB527556	Counter Belt D93x1.5	ND-1022	1
6-114	MZ317406	Brake Band Guide, w/base	MR-120	2
6-115	BL316484	AS Lever Block Comp.	MU, MC, MS, MR	1
6-116	ZG260706	AS Lever Spring	4TR-118	1
6-117	ZW290294	'U' Ring 2.85M	6-1-1B	1
6-118x	MP271170	Pinch Roller, LC D=38	LC-321	1
6-119	EJ450573	Mate-N-Lock Cap Housing 9P 1-480277-0	52-1-7	1
6-120x	EJ373623	Pin Contact 61116-1	52-1-1	12
6-121	ES375478	Slide SW. ESD-279DU, w/knob(black)	25-3-23	1
6-122	ZS444273	ISO Screw, binding head 3x4		4
6-123	ML544307	SW. Retaining Plate S	MU-1001	1
6-124	ZS413728	Screw, binding head 3x6, w/washer		1
6-125	EJ510333	Wire Clip 220-JD481610-0104 (Nylon)	2-7-17	1
6-126x	MZ219576	Cord Retainer D	M9-123	1
6-127	EJ205975	Cramp Terminal 1-SD	32-1-7	7
6-128x	EJ205986	Cramp Terminal 2-SD	32-1-8	1
6-129	ZG217394	Belt Change Spring B	MH-125	1
6-130	ZW260054	Washer (SUP)D6.1x10x0.25t		1
6-131	ZW290283	'U' Ring 2.85M	6-1-1	1

FIG. 7 PHOTO OF SYSTEM CONTROL P.C. BOARD (MU-1202)

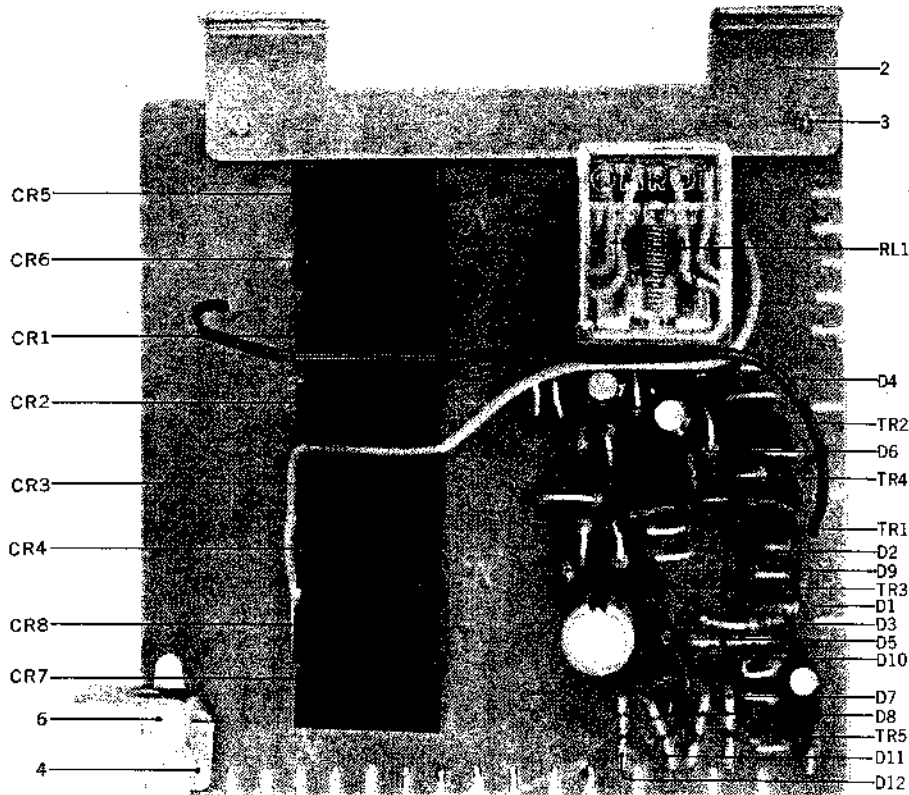

**SYSTEM CONTROL P.C. BOARD (MU-1202)
BLOCK**

Symbol No.	Parts No.	Description	Q'ty	Symbol No.	Parts No.	Description	Q'ty
7-1x	BA563567	System Control P.C. Board Comp. (MU-1202)	1			Resistor, Stopper Type	
7-TR1to4	ET398711	Transistor 2SC945(Q)(R)	4	7-R1	ER211667	Carbon RD1/4 100(J)	1
7-TR5	ET453486	Transistor 2SC711(E)(F)	1	7-R2	ER336442	Carbon RD1/4 10k(J)	1
7-D1, 2	ED560913	Silicon Diode 1S2473 VE	2	7-R3	ER212883	Carbon RD1/4 4.7k(J)	1
7-D3	ED219464	Germanium Diode 1N34A	1	7-R4	ER212477	Carbon RD1/4 3.3k(J)	1
7-D4	ED536062	Silicon Diode WG-713	1	7-R5	ER211667	Carbon RD1/4 100(J)	1
7-D5, 6	ED514721	Silicon Diode WG-599	2	7-R6, 7	ER212883	Carbon RD1/4 4.7k(J)	2
7-D7to12	ED560913	Silicon Diode 1S2473 VE	6	7-R8	ER336442	Carbon RD1/4 10k(J)	1
7-RL1	EP344136	Relay MY4-O-US-AD4 24V	1	7-R9	ER357456	Carbon RD1/4 2.2k(J)	1
7-CR1to8	ER450786	Spark Quencher U/L 0.1μ+120Ω 400WV	8	7-R10	ER211757	Carbon RD1/4 100k(J)	1
7-2	EZ544320	P.C. Board Holder A	1	7-R11	ER212264	Carbon RD1/4 22k(J)	1
7-3	ZS447772	Tapping Screw #2 3x6(BR)	2	7-R12	ER212883	Carbon RD1/4 4.7k(J)	1
7-4	MZ544331	P.C. Board Holder B	1	7-R13	ER212264	Carbon RD1/4 22k(J)	1
7-5x	ZS413155	Screw, binding head 3x6	2	7-R14	ER357456	Carbon RD1/4 2.2k(J)	1
7-6	EJ510333	Wire Clip 220-JD481610-0104 (Nylon)	1	7-R15	ER211667	Carbon RD1/4 100(J)	1
		Capacitor, Vertical Type		7-R16	ER212264	Carbon RD1/4 22k(J)	1
7-C1	EC220994	Elect. 10μF 25WV	1	7-R17, 18	ER336442	Carbon RD1/4 10k(J)	2
7-C2	EC383501	Mylar 0.001μF(M) 50WV	1	7-R19	ER342933	Carbon RD1/4 27k(J)	1
7-C3, 4	EC250918	Mylar 0.01μF(M) 50WV	2	7-R20	ER336442	Carbon RD1/4 10k(J)	1
7-C5	EC391498	Mylar 0.022μF(M) 50WV	2				
7-C6	EC220678	Elect. 47μF 25WV	1				
7-C7	EC391498	Mylar 0.022μF(M) 50WV	2				
7-C8	EC220994	Elect. 10μF 25WV	1				
7-C9	EC250885	Mylar 0.01μF(K) 50WV	1				
7-C10	EC450055	Elect. 1μF 25WV	1				
7-C11	EC220432	Elect. 2.2μF 25WV	1				

When ordering parts, please describe Parts Number, Serial Number, and Model Number in detail.

FIG. 8 PHOTO OF CR P.C. BOARD (MU-1007)

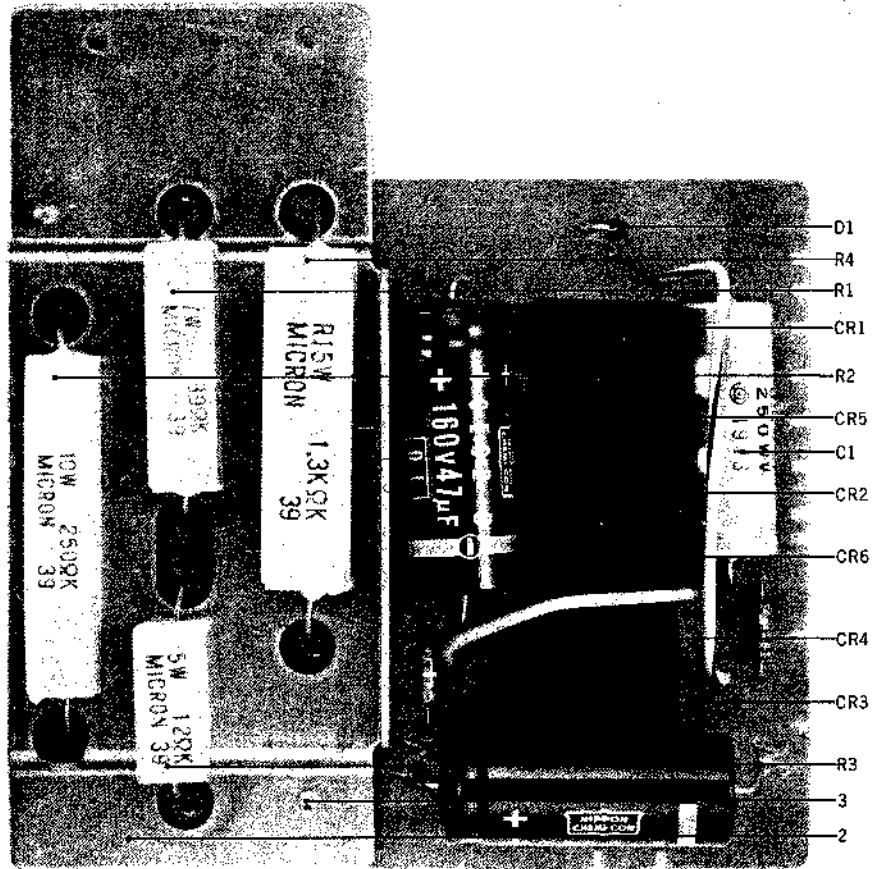

CR P.C. BOARD (MU-1007) BLOCK

Symbol No.	Parts No.	Description	Q'ty
8-1x	BA563556	CR P.C. Board Comp. (MU-1007)	1
8-D1	ED224550	Silicon Diode 10D4	1
8-CR1to6	ER450786	Spark Quencher U/L 0.1 μ +120 Ω 400WV	6
8-2	MZ544342	P.C. Board Holder C	1
8-3	ZS447772	Tapping Screw #2 3x6(BR)	2
		Capacitor, Tubular Type	
8-C1	EC350987	MP 0.47 μ F(M) 250VAC	1
8-C2, 3	EC316113	Elect. 47 μ F 160WV	2
		Resistor, Wire-wound Type	
8-R1	ER554883	Cement 7W 39(K)	1
8-R2	ER554861	Cement 10W 250(K)	1
8-R3	ER554905	Cement 5W 12(K)	1
8-R4	ER565121	Cement 15W 1.3k(K) (Metal Ox. Film type)	1
8-R5	ER365016	Carbon RD1/4 220k(J) (Insu. type)	1
8-R6	ER324808	Carbon RD1/4 100(J) (Insu. type)	1

FIG. 9 PHOTO OF REC. AMP. P.C. BOARD (MU-5238)

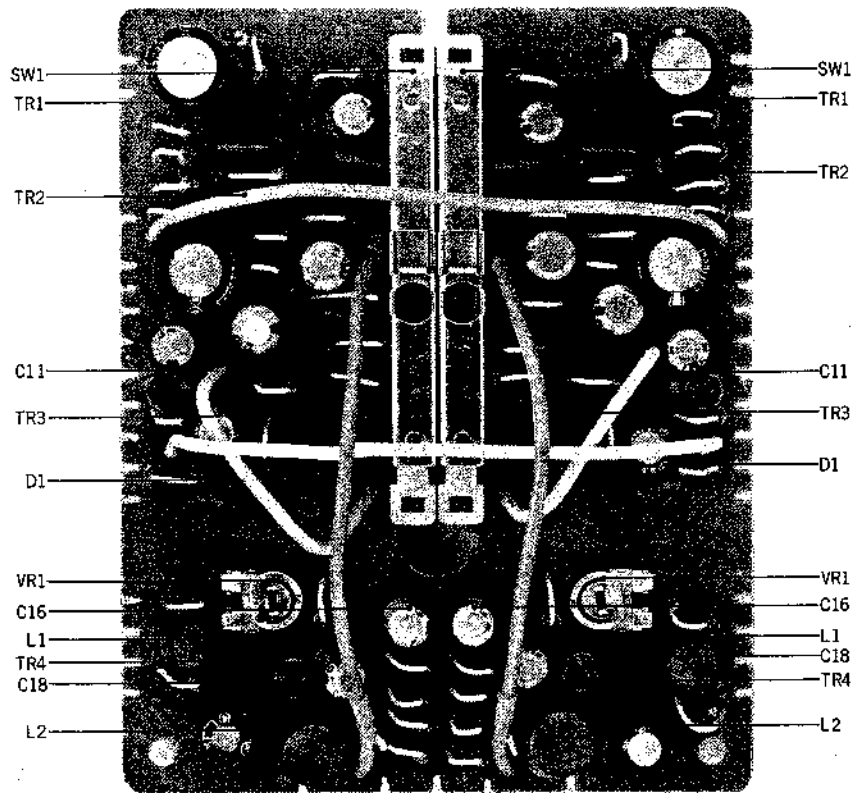

REC. AMP. P.C. BOARD (MU-5238) BLOCK

Symbol No.	Parts No.	Description	Q'ty	Symbol No.	Parts No.	Description	Q'ty
9-1x	BA563591	Rec. Amp. P.C. Board Comp. (MU-5238)	1				
9-TR1, 2	ET517263	Transistor 2SC1312(G) (H)	4	9-R1	ER336442	Resistor, Stopper Type Carbon RD1/4 10k(J)	2
9-TR3, 4	ET453486	Transistor 2SC711(E) (F)	4	9-R2	ER362485	Carbon RD1/4 330k(J)	2
9-D1	ED520762	Zener Diode YZ-088A	2	9-R3	ER336442	Carbon RD1/4 10k(J)	2
9-SW1	ES496642	Slide SW. CL106B(CL162A25)	2	9-R4	ER362485	Carbon RD1/4 330k(J)	2
9-VR1	EV464207	Semi-fixed Vol. V8K4-1 5 kΩ	2	9-R5	ER212477	Carbon RD1/4 3.3k(J)	2
9-L1	EO369178	Ferri Inductor FL7H 1.5MH(J)	2	9-R6	ER357570	Carbon RD1/4 150k(J)	2
9-L2	EO244012	Ferri Inductor FL9H 22MH(J)	2	9-R7	ER343135	Carbon RD1/4 1.6k(J)	2
		Capacitor, Vertical Type		9-R8	ER346994	Carbon RD1/4 18k(J)	2
9-C1	EC220678	Elect. 47μF 25WV	2	9-R9	ER343078	Carbon RD1/4 2.7k(J)	2
9-C2	EC320051	Elect. 10μF 16WV	2	9-R10	ER343135	Carbon RD1/4 1.6k(J)	2
9-C3	EC451462	VFM 150PF(J) 50WV	4	9-R11,12	ER336442	Carbon RD1/4 10k(J)	4
9-C4	EC290531	VFM 100PF(K) 50WV	2	9-R13	ER399060	Carbon RD1/4 9.1k(J)	2
9-C5	EC329771	Elect. 47μF 6.3WV	2	9-R14	ER342933	Carbon RD1/4 27k(J)	2
9-C6	EC357827	VFM 50PF(K) 50WV	2	9-R15	ER357570	Carbon RD1/4 150k(J)	2
9-C7	EC220151	Elect. 100μF 25WV	2	9-R16	ER349828	Carbon RD1/4 20k(J)	2
9-C8	EC320051	Elect. 10μF 16WV	2	9-R17	ER429996	Carbon RD1/4 470k(J)	2
9-C9	EC329771	Elect. 47μF 6.3WV	2	9-R18	ER212264	Carbon RD1/4 22k(J)	2
9-C10	EC399565	VFM 22PF(J) 50WV	2	9-R19	ER336442	Carbon RD1/4 10k(J)	2
9-C11	EC562678	StyroI 750PF(J) 50WV	2	9-R20,21	ER212883	Carbon RD1/4 4.7k(J)	4
9-C13	EC250841	Mylar 0.01μF(J) 50WV	2	9-R22	ER212174	Carbon RD1/4 180k(J)	2
9-C14	EC331705	Elect. 22μF 16WV	2	9-R23	ER336442	Carbon RD1/4 10k(J)	2
9-C15	EC320051	Elect. 10μF 16WV	2	9-R24	ER211858	Carbon RD1/4 12k(J)	2
9-C16	EC487157	NP 0.47μF(M) 50WV	2	9-R25	ER211465	Carbon RD1/4 1k(J)	2
9-C17	EC220994	Elect. 10μF 25WV	2				
9-C18	EC516745	StyroI 330PF(K) 50WV	2				
9-C19	EC451462	VFM 150PF(J) 50WV	2				
9-C20	EC435690	StyroI 560PF(J) 50WV	2				

When ordering parts, please describe Parts Number, Serial Number, and Model Number in detail.

**FIG. 10 PHOTO OF P.B. AMP. P.C. BOARD
(MU-5239)**

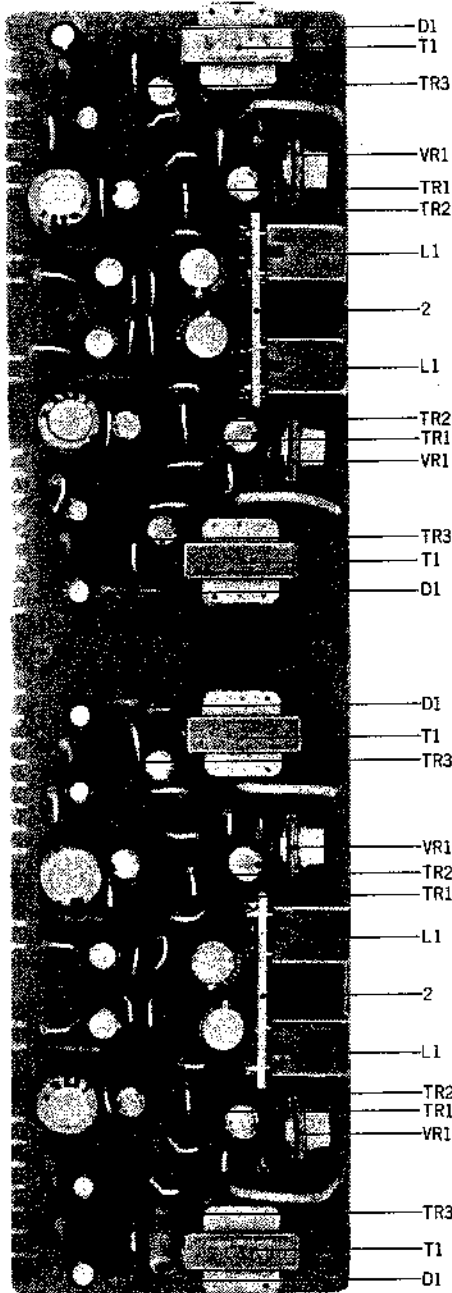

P.B. AMP. P.C. BOARD (MU-5239) BLOCK

Symbol No.	Parts No.	Description	Q'ty
10-1x	BA563602	P.B. Amp. P.C. Board Comp. (MU-5239)	1
10-TR1	ET517263	Transistor 2SC1312(G) (H)	4
10-TR2, 3	ET453486	Transistor 2SC711(E) (F)	8
10-D1	ED219464	Germanium Diode 1N34A	4
10-L1	EO346230	Inductor RX 22MH	4
10-2	EA549246	Coil P.C. Board (MU-5240)	2
10-VR1	EV538402	Semi-fixed Vol. V10K8-1-5 30 k(4US)	4
10-T1	BT247768	Headphone Trans. N19-5921S	4
Capacitor, Vertical Type			
10-C1	EC329850	VFM 220PF(J) 50WV	4
10-C2	EC320051	Elect. 10 μ F 16WV	4
10-C3	EC336126	Elect. 47 μ F 25WV	4
10-C4	EC329771	Elect. 47 μ F 6.3WV	4
10-C5	EC324516	Elect. 220 μ F 6.3WV	4
10-C6	EC451462	VFM 150PF(J) 50WV	4
10-C7	EC220994	Elect. 10 μ F 25WV	4
10-C8	EC250604	Mylar 0.001 μ F(K) 50WV	4
10-C9	EC450055	Elect. 1 μ F 25WV	4
10-C10	EC320051	Elect. 10 μ F 16WV	4
10-C11	EC450527	Elect. 4.7 μ F 25WV	4
Resistor, Stopper Type			
10-R1	ER212883	Carbon RD1/4 4.7k(J)	4
10-R2	ER420322	Carbon RD1/4 36k(J)	4
10-R3	ER306843	Carbon RD1/4 1.2k(J)	4
10-R4	ER563455	Carbon RD1/4 91(J)	4
10-R5	ER357412	Carbon RD1/4 220(J)	4
10-R6	ER357491	Carbon RD1/4 82k(J)	4
10-R7	ER357456	Carbon RD1/4 2.2k(J)	4
10-R8	ER211667	Carbon RD1/4 100(J)	4
10-R9	ER406912	Carbon RD1/4 240(J)	4
10-R10	ER211757	Carbon RD1/4 100k(J)	4
10-R11	ER350100	Carbon RD1/4 68k(J)	4
10-R12	ER212883	Carbon RD1/4 4.7k(J)	4
10-R13	ER304402	Carbon RD1/4 470(f)	4
10-R14	ER212264	Carbon RD1/4 22k(J)	4

FIG. 11 PHOTO OF EQ. P.C. BOARD
(MU-5241)

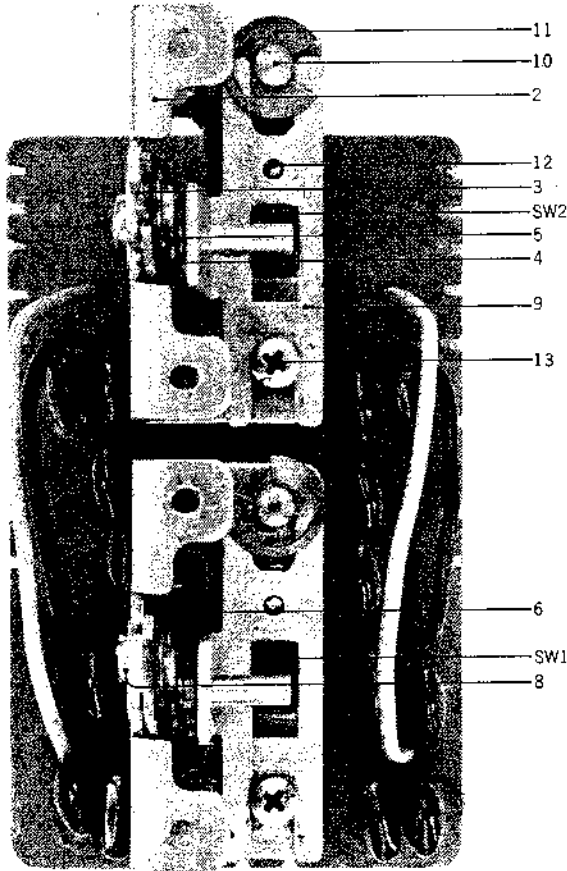
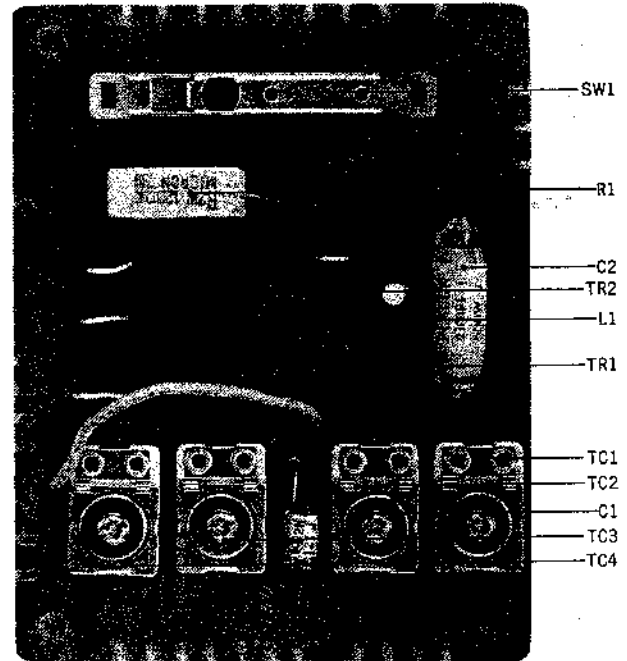

FIG. 12 PHOTO OF OSC. P.C. BOARD
(MU-5242)



EQ. P.C. BOARD (MU-5241) BLOCK

Symbol No.	Parts No.	Description	Q'ty
11-1x	BA563613	Eq. P.C. Board Comp. (MU-5241)	1
11-SW1, 2	ES446117	Slide SW. SL-282A2	2
11-2	EZ548357	Switch Base B	2
11-3	ML549630	Selector Lever B	2
11-4	ZW322525	Washer (PBP)D4.1x7x0.2t	2
11-5	ZW270101	'E' Ring 3M	2
11-6	ZG548403	Operation Spring	2
11-7x	ZW270088	'E' Ring 1.9M	2
11-8	ZS413155	Screw, binding head 3x6	2
11-9	EZ548381	Slider	2
11-10	ZW548370	Slide Pin B	2
11-11	ZW290283	'U' Ring 2.85M	2
11-12	ZS442585	Screw, binding head 2.6x4	2
11-13	ZS563444	Screw, binding head 2.6x8	2
		Capacitor, Vertical Type	
11-C1to4	EC392016	Mylar 0.068 μ F(J) 50WV	4
11-C5to8	EC379203	Mylar 0.039 μ F(J) 50WV	4
11-C9to12	EC379168	Mylar 0.033 μ F(J) 50WV	4
11-C13to16	EC329872	Mylar 0.027 μ F(J) 50WV	4

OSC. P.C. BOARD (MU-5242) BLOCK

Symbol No.	Parts No.	Description	Q'ty
12-1x	BA563646	OSC. P.C. Board Comp. (MU-5242)	1
12-TR1, 2	ET398711	Transistor 2SC945(Q) (R)	2
12-TC1 to 4	EC558202	Trimmer/C. TM-80A	4
12-L1	EO383365	OSC. Coil OT-204	1
12-SW1	ES494302	Slide SW. CL-104B	1
		Capacitor, Vertical Type	
12-C1	EC563422	Styrol 120PF(J) 500WV(Tub. type)	1
12-C2	EC435655	Plastic Film 2700PF(J) 500WV	1
12-C3	EC450055	Elect. 1 μ F 25WV	1
12-C4, 5	EC250841	Mylar 0.01 μ F(J) 50WV	2
		Resistor, Stopper Type	
12-R1	ER466525	Cement 2W 120(K) (Metal Oxide type)	1
12-R2	ER212883	Carbon RD1/4 4.7k(J)	1
12-R3	ER304402	Carbon RD1/4 470(J)	1
12-R4, 5	ER315944	Carbon RD1/4 3.3(J)	2

FIG. 13 PHOTO OF POWER SUPPLY P.C. BOARD (MU-5017)

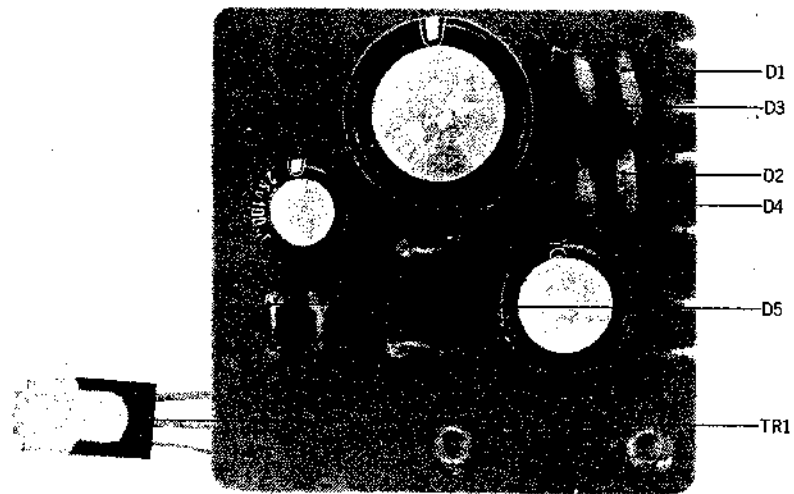

**POWER SUPPLY P.C. BOARD
(MU-5017) BLOCK**

Symbol No.	Parts No.	Description	Q'ty
13-1x	BA558450	Power Supply P.C. Board Comp. (MU-5017)	1
13-TR1	ET495371	Transistor 2SC1098(L)	1
13-D1to4	ED494583	Silicon Diode 10D05	2
13-D5	ED511918	Zener Diode WZ-240	1
13-2x	ZS323728	Screw, binding head 3x5	1
Capacitor, Vertical Type			
13-C1	EC557651	Elect. 470 μ F 50WV	1
13-C2	EC220151	Elect. 100 μ F 25WV	1
13-C3	EC336115	Elect. 220 μ F 25WV	1
Resistor, Stopper Type			
13-R1	ER306843	Carbon RD1/4 1.2k(J)	1
13-R2	ER211667	Carbon RD1/4 100(J)	1
13-R3	ER430018	Carbon RD1/4 1(J)	1

FIG. 14a PHOTO OF AMPLIFIER ASSEMBLY BLOCK

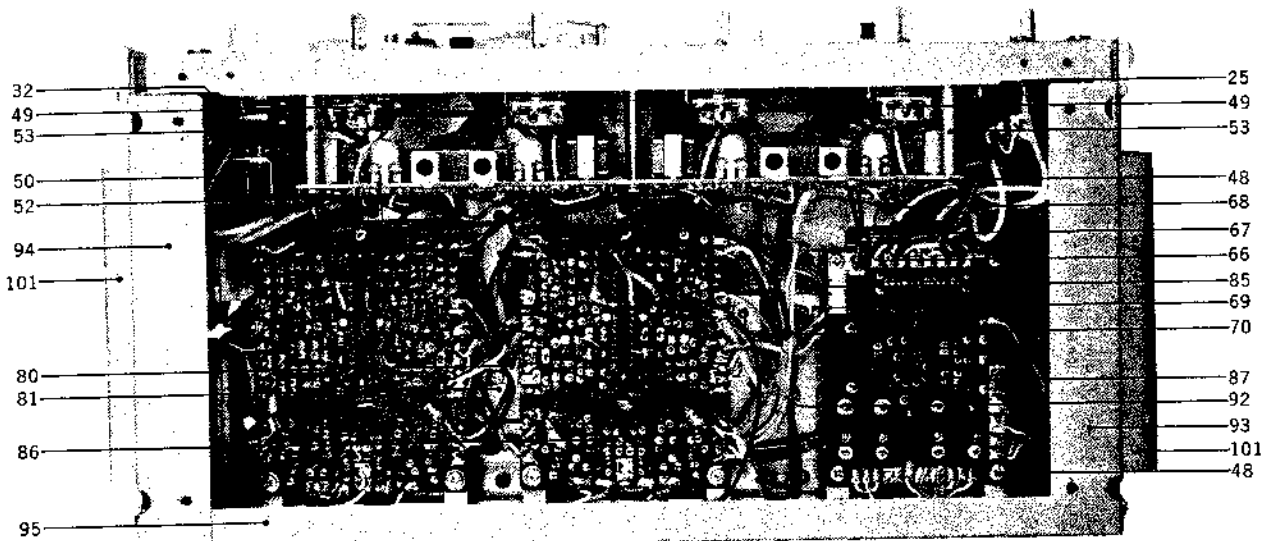
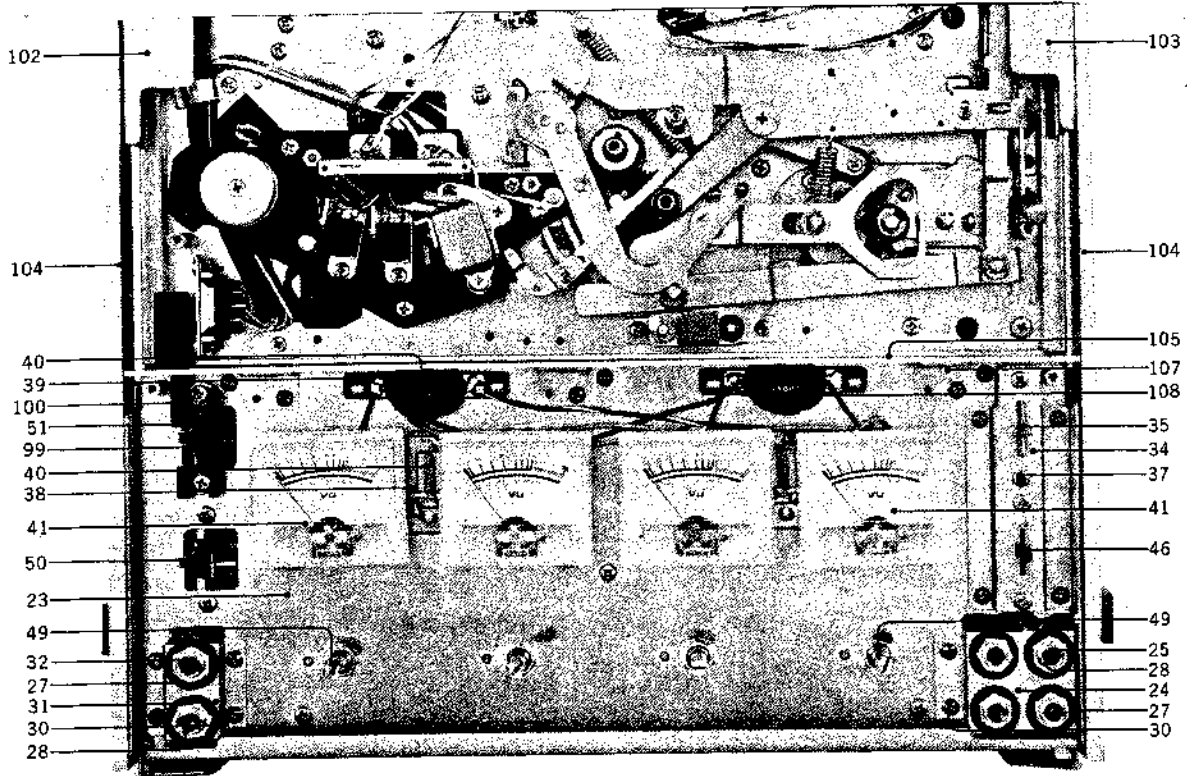
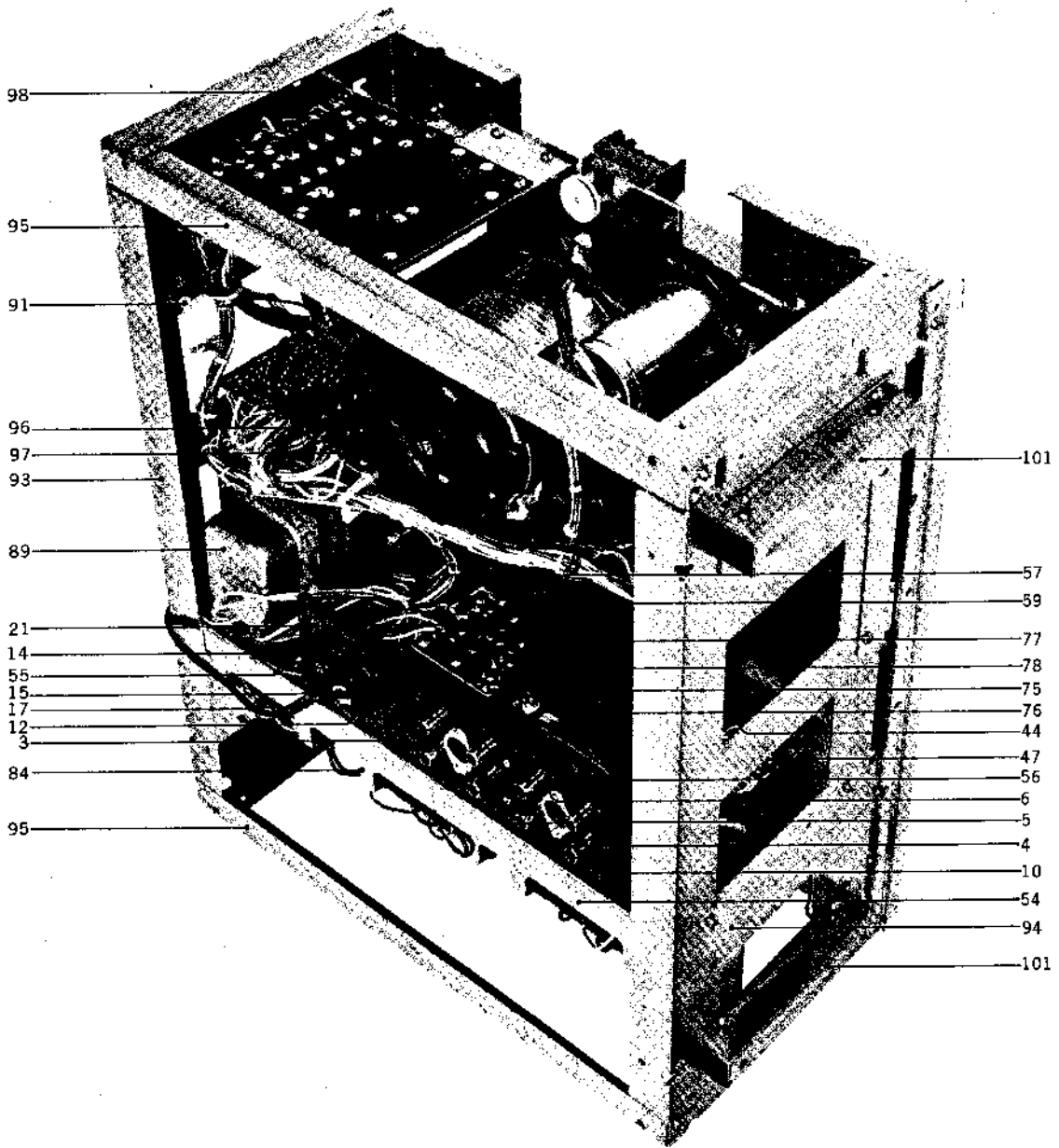

FIG. 14b PHOTO OF AMPLIFIER ASSEMBLY BLOCK



AMPLIFIER ASSEMBLY BLOCK

Ref. No.	Parts No.	Description	Schematic No.	Q'ty	Ref. No.	Parts No.	Description	Schematic No.	Q'ty
JACK PLATE BLOCK					14-12	EJ233370	Socket (Volt. Selector)		
14-1x	BZ563624	Jack Plate Block Comp.	MU-2	1			S-18010	40-2-3	1
14-2x	BZ563635	Jack Plate Block Comp.			14-13x	EF558066	Fuse 2A 125V	39-1-47	1
		(3 core)	MU-2	1	14-14	ZS372025	ISO Screw, truss head 3x6		2
14-3	EZ548741	Jack Plate Bracket	MU-5231	1	14-15	EZ382263	Strain Relief SR-4K-4	2-7-12	1
14-4	EJ563433	Jack Plate MU-2 (w/jack)	31-5-86	1	14-16x	EZ246936	Strain Relief SR-6W-1		
14-5	ES446973	Slide SW. SL-242B4D	25-3-51	1			(WG, 3 core)	2-7-8	1
14-6	EA549270	Jack P.C. Board	MU-5237	1	14-17	EW540112	AC Cord (CUL) 2.5M	26-3-19	1
14-7x	ER589375	Carbon/R. RD1/4 680k(J)			14-18x	EW315448	Australia Cord (3 core)	26-3-11	1
		(Insu. type)	35-9-10	4	14-19x	EW524845	AC Cord (J) 2.5M	26-3-31	1
14-8x	ER558573	Carbon/R. RD1/4 27k(J)			14-20x	ZW273778	Earth Lug M3		1
		(Insu. type)	35-9-10	4	14-21	BA558450	Power Supply P.C. Board		
14-9x	ER368133	Carbon/R. RD1/4 22k(J)					Comp. (MU-5017)		1
		(Insu. type)	35-9-10	8	14-22x	ZS447772	Tapping Screw #2 3x6(BR).		2
14-10	ZS201183	Screw, truss head 3x8(black)		4					
14-11x	ZW273756	Nut M3		4					

When ordering parts, please describe Parts Number, Serial Number, and Model Number in detail.

Ref. No.	Parts No.	Description	Schematic No.	Q'ty	Ref. No.	Parts No.	Description	Schematic No.	Q'ty
AMP. ASSEMBLY BLOCK					14-87	BA563646	OSC. P.C. Board Comp. (MU-5242)		1
14-23	EZ548908	Amp. Plate, w/stand	MU-5201	1	14-88x	UM388348	Power Supply Trans. Shield Plate, CSA	CS-5016	1
14-24	EZ548313	Jack Base A	MU-5203	1	14-89	BT563411	Power Trans. MUT-4	38-4-263	1
14-25	EJ448075	Mic. Jack 2PMJ1	31-2-23	4	14-90x	ZS462925	Tapping Screw #2 4x8(BR)		4
14-26x	EZ225180	Nylon Collar, Jack	LD-520	4	14-91	EJ514607	Wire Clip 220-JD485210-01 (Nylon)	2-7-18	2
14-27	ZW260368	Washer (Fiber)D9.2x18x0.5t		6	14-92	EJ510333	Wire Clip 220-JD481610-0104 (Nylon)	2-7-17	4
14-28	ZW554624	Nut, E Jack	7-1-56	6	14-93	EZ548965	Side Chassis R, w/angle	MU-5232	1
14-29x	ER315213	Carbon/R. RD1/4 8.2k(J) (Insu. type)	35-9-5	4	14-94	EZ548976	Side Chassis L, w/angle	MU-5232	1
14-30	ZS447772	Tapping Screw #2 3x6(BR)		52	14-95	EZ548763	Reinforcement Angle	MU-5234	2
14-31	EZ548324	Jack Base B	MU-5204	1	14-96	SZ529108	Main Motor Fan	ND-7010	1
14-32	EJ447603	Mic. Jack 3PMJ1	31-2-24	2	14-97	ZW270134	'E' Ring 5M	6-1-9	1
14-33x	ZW272722	Toothed Lock Washer M9 D9.3x13x0.5t		2	14-98	SZ544476	P.C. Board Holder D	MU-6016	1
14-34	EZ548302	SW. Base	MU-5202	1	14-99	SZ548594	Coupling Plate	MU-6201	1
14-35	ES436983	Lever SW. SDD2LCPO (LPS60112CPOO)	25-4-9	1	14-100	ZS425981	Screw, binding head 3x3		2
14-36x	ER450797	Spark Quencher U/L 0.033μ+120Ω 400WV	41-1-34	1	14-101	SZ548605	Side Plate Support	MU-6202	4
14-37	ZS379405	ISO Screw, binding head 3x6		4	14-102	SZ544465	Reinforcement Plate L	MU-6015	1
14-38	EA476256	Lamp P.C. Board	MR-5004	2	14-103	SZ544691	Reinforcement Plate R	MU-6015	1
14-39	EA449414	Lamp P.C. Board	BS-5005	2	14-104	SE548921	Sash	MU-6206	2
14-40	EL295312	Lamp (No. 2) 8V 0.2A	28-2-8	4	14-105	SE548774	Sash B	MU-6204	1
14-41	EM558180	VU Meter KL-243S-5	46-1-74	4	14-106x	ZS200384	Screw, countersunk head 3x6		3
14-42x	EZ449471	VU Mat	BS-5010	4	14-107	SZ548616	Sash Bracket	MU-6203	3
14-43x	EJ293073	Mate-N-Lock Plug Housing 12P 1-480275-0	52-1-1	1	14-108	UM494267	Lamp Cover	CG-2206	2
14-44	EJ430378	Multi-jack 14P 3252-014-001	31-4-14	1					
14-45x	EJ373634	Socket Contact 61115-1	52-1-1	12					
14-46	ES443013	Lever SW. SQ11 12-4-2 Black(M)	25-12-3	1					
14-47	EZ548414	Jack Metal Parts	MU-5215	1					
14-48	ZS413155	Screw, binding head 3x6		25					
14-49	EV476223	Volume V24N 50 kA	36-2-26	4					
14-50	BA563613	EQ. P.C. Board Comp. (MU-5241)		1					
14-51	MH548335	Slide Prop	MU-5206	2					
14-52	BA563602	P.B. Amp. P.C. Board Comp. (MU-5239)		1					
14-53	EZ548583	P.C. Board Stand C	MU-5236	3					
14-54	EZ548910	Amp. Chassis	MU-5214	1					
14-55	EZ548572	Amp. Chassis Reinforcement Plate	MU-5235	1					
14-56	ES563387	Leaf SW. BSW-1A	25-10-19	1					
14-57	EP563398	Plunger Solenoid 0730THTI-3	44-1-64	1					
14-58x	ED224548	Silicon Diode 10D2	45-2-14	1					
14-59	EZ548504	Plunger Base	MU-5224	1					
14-60x	ZS442585	Screw, binding head 2.6x4		2					
14-61x	EZ548515	Pull Plate	MU-5225	1					
14-62x	ZW548548	Pin	MU-5228	1					
14-63x	ZW357164	'E' Ring 2.3M	6-1-9	1					
14-64x	UM494414	Joint Pin	CG-1206	1					
14-65x	ZW270088	'E' Ring 1.9M	6-1-9	3					
14-66	EZ548550	Lever Mt. Plate	MU-5229	1					
14-67	ML548526	Lever, w/plate	MU-5226	1					
14-68	EZ548561	Lever Shaft	MU-5230	1					
14-69	ML548458	R Lever	MU-5219	1					
14-70	MH314280	Rec. Lever Pin	MR-528	1					
14-71x	ZW273892	Toothed Lock Washer M4		1					
14-72x	ZW416698	Nut M4		1					
14-73x	ZS314717	Graduated Screw, MR	MR-254	2					
14-74x	ZW273756	Nut M3		6					
14-75	ML548436	Rec. Lever	MU-5217	1					
14-76	ZS207314	Amp. Lever Set Screw	3A-737	2					
14-77	ZG548447	Rec. Spring	MU-5218	1					
14-78	ZG431291	Slide Spring	ED-B108	1					
14-79x	ZW273778	Earth Lug M3		1					
14-80	ML548460	R Lever A, w/pin	MU-5220	1					
14-81	ML548482	R Lever B	MU-5222	1					
14-82x	ZW290283	'U' Ring 2.85M	6-1-1	2					
14-83x	MH548493	R Prop	MU-5223	2					
14-84	EZ548730	P.C. Board Stand A	MU-5205	1					
14-85	EZ548425	P.C. Board Stand B	MU-5216	4					
14-86	BA563591	Rec. Amp. P.C. Board Comp. (MU-5238)		2					

When ordering parts, please describe Parts Number, Serial Number, and Model Number in detail.

FIG. 15 PHOTO OF FINAL ASSEMBLY BLOCK

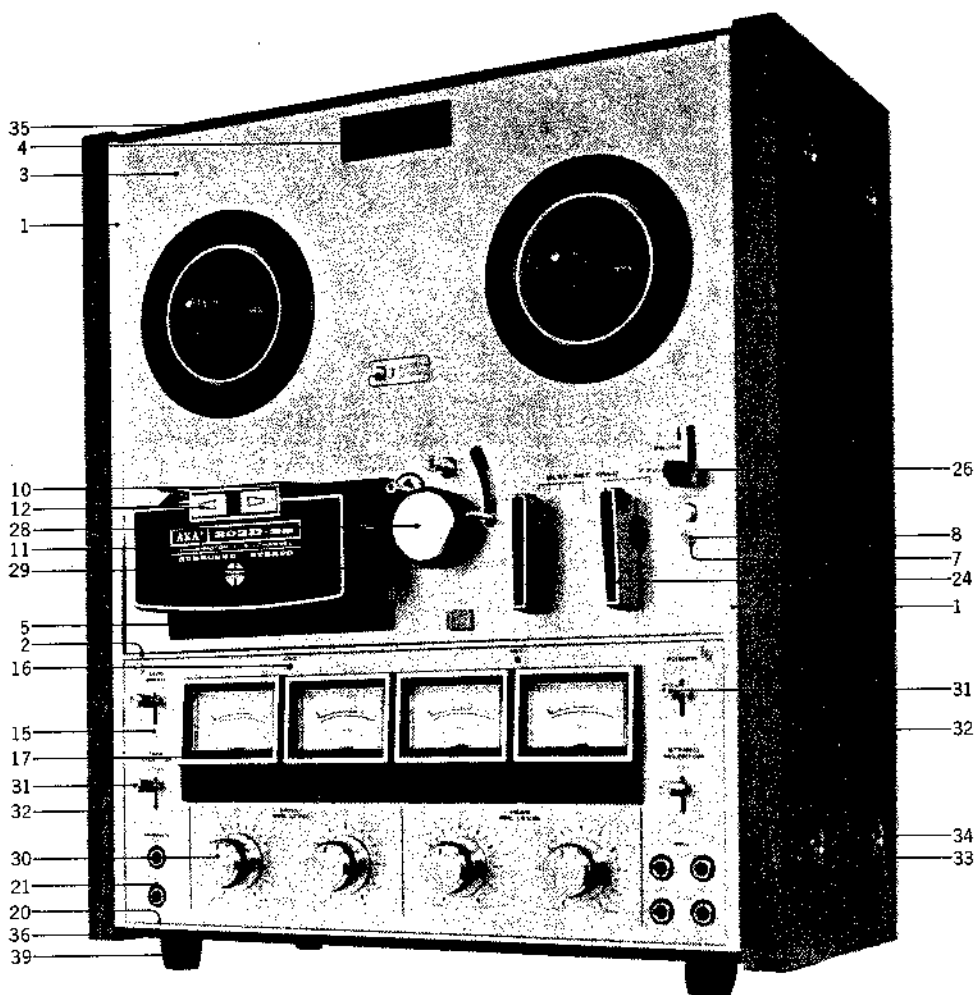

FINAL ASSEMBLY BLOCK

Ref. No.	Parts No.	Description	Schematic No.	Q'ty	Ref. No.	Parts No.	Description	Schematic No.	Q'ty
15-1	SE548921	Sash	MU-6206	2	15-25x	ZS253405	Mech. Knob Screw	7-1-46	2
15-2	SE548774	Sash B	MU-6204	1	15-26	SK314100	Pause Knob B	MR-612	1
15-3	SP548932	Mech. Panel A, w/ring	MU-6206	1	15-27x	ZS356804	Set Screw, hexagon socket		1
15-4	SE528906	Counter Escutcheon	ND-6008	1			3x4(cup)		1
15-5	SC544533	Head Cover Base	MU-6003	1	15-28	SK425158	Pinch Roller Cap	MS-6020	1
15-6x	ZS413155	Screw, binding head 3x6		4	15-29	MP271170	Pinch Roller, LC D=38	LC-321	1
15-7	ZW408418	Panel Washer	KD-6029	4	15-30	SK548662	Volume Knob Comp.	MU-6219	4
15-8	ZS563308	Screw, oval countersunk head		4	15-31	SK442765	Lever SW. Knob A-1	81-5603	4
		3x6		4	15-32	BC548796	Side Plate	MU-6211	2
15-9x	HZ579126	Head Shield Plate	MU-6228	1	15-33	ZW548010	Spot Facing Washer	MU-6028	8
15-10	SC544544	Head Cover	MU-6004	1	15-34	ZS563321	Screw, binding head 4x14		8
15-11	SM548673	Head Cover Name Plate	MU-6220	1	15-35	SP548807	Upper Plate	MU-6212	1
15-12	SB544454	Direction Button	MU-6006	2	15-36	SP548818	Lower Plate	MU-6212	1
15-13x	ZS355511	Screw, binding head 3x6(black)		2	15-37x	ZW461610	Decorative Washer 3M		4
15-14x	ZS325495	Tapping Screw #2 3x6		5	15-38x	ZS482815	Screw, oval countersunk head		4
15-15	SP548954	Amp. Panel	MU-6208	1			3x8		4
15-16	SZ457975	Lamp Lens B (Red)	66-5012	2	15-39	SA377190	Rubber Foot, LM	LM-404	8
15-17	SE544601	VU Meter Escutcheon	MU-6017	4	15-40x	ZW419646	Washer (SPC)D4.5x9.8x0.5t		8
15-18x	SZ548897	Escutcheon Support	MU-6221	4	15-41x	ZS487776	Screw, truss head 4x18		8
15-19x	ZS425788	Screw, round head 3x4		8	15-42x	SP548820	Back Plate A	MU-6213	1
15-20	SE548785	Sash C	MU-6210	1	15-43x	ZS498273	Tapping Screw #2 3x8, w/washer		2
15-21	ZW526577	Collar B, Jack	MC-5006	6	15-44x	EF304626	Fuse ST-4 1A	39-1-28	1
15-22x	ZS447772	Tapping Screw #2 3x6(BR)		2	15-45x	EF558066	Fuse 2A 125V	39-1-47	1
15-23x	ZW432347	Washer (Luminar)		2					
		D6.2x13x0.125t		2					
15-24	SK476684	Mech. Knob	LE-6018	2					

When ordering parts, please describe Parts Number, Serial Number, and Model Number in detail.

INDEX

Parts No.	Ref. No. & Symbol No.	Parts No.	Ref. No. & Symbol No.	Parts No.	Ref. No. & Symbol No.	Parts No.	Ref. No. & Symbol No.	Parts No.	Ref. No. & Symbol No.
BA558450	13-1x	EC451462	9-C3	ER336442	7-R17,18	EZ548414	14-47	ML396810	2-23x
BA558450	14-21	EC451462	9-C19	ER336442	7-R20	EZ548425	14-85	ML396810	6-88x
BA563556	8-1x	EC451462	10-C6	ER336442	9-R1	EZ548504	14-59	ML540990	3-12
BA563567	7-1x	EC487157	9-C16	ER336442	9-R3	EZ548515	14-61x	ML541001	3-13
BA563591	9-1x	EC516745	9-C18	ER336442	9-R11,12	EZ548550	14-66	ML544285	1-49
BA563591	14-86	EC520626	6-41	ER336442	9-R19	EZ548561	14-68	ML544307	6-123
BA563602	10-1x	EC557651	13-C1	ER336442	9-R23	EZ548572	14-55	ML548436	14-75
BA563602	14-52	EC558202	12-TC1to4	ER342933	7-R19	EZ548583	14-53	ML548458	14-69
BA563613	11-1x	EC562678	9-C11	ER342933	9-R14	EZ548730	14-84	ML548460	14-80
BA563613	14-50	EC563422	12-C1	ER343078	9-R9	EZ548741	14-3	ML548482	14-81
BA563646	12-1x	ED219464	7-D3	ER343135	9-R7	EZ548763	14-95	ML548526	14-67
BA563646	14-87	ED219464	10-D1	ER343135	9-R10	EZ548908	14-23	ML549213	6-86
BC548796	15-32	ED224548	14-58x	ER346994	9-R8	EZ548910	14-54	ML549630	11-3
BF476550	4-1x	ED224550	8-D1	ER349828	9-R16	EZ548965	14-93	MP271170	6-118x
BH563545	1-1x	ED494583	13-D1to4	ER350100	10-R11	EZ548976	14-94	MP271170	15-29
BL204480	5-29x	ED511918	13-D5	ER357412	10-R5	HA445116	1-17	MR217203	5-31
BL316484	6-115	ED514721	7-D5, 6	ER357456	7-R9	HE552914	1-12	MR269730	5-12
BL555344	3-11x	ED520762	9-D1	ER357456	7-R14	HE563220	1-15	MR269763	6-81
BM314741	2-1	ED536062	7-D4	ER357456	10-R7	HL541157	1-58	MR314785	6-61
BM563196	3-1	ED560913	7-D1, 2	ER357491	10-R6	HL541168	1-56	MR317507	2-16
BR317384	2-3x	ED560913	7-D7to12	ER357570	9-R6	HL542687	1-57	MR540876	3-3
BR317395	2-2x	EF304626	15-44x	ER357570	9-R15	HP412165	1-18	MS243404	6-78
BS558336	5-1x	EF558066	14-13x	ER362485	9-R2	HZ274162	1-5	MS250536	6-33
BT247768	10-T1	EF558066	15-45x	ER362485	9-R4	HZ315077	6-95	MS260515	6-31
BT563411	14-89	EJ205975	6-127	ER365016	8-R5	HZ315090	6-96	MS316721	6-4
BZ248027	6-13x	EJ205986	6-128x	ER368133	14-9x	HZ317092	1-43	MS316776	6-9
BZ558347	6-1x	EJ233370	14-12	ER399060	9-R13	HZ317597	1-8	MS317362	6-24
BZ563624	14-1x	EJ293073	14-43x	ER406912	10-R9	HZ317632	1-30	MS342000	2-6
BZ563635	14-2x	EJ373623	6-120x	ER420322	10-R2	HZ318036	1-32	MS476572	4-3
EA222096	1-27x	EJ373634	14-45x	ER429996	9-R17	HZ318047	1-31	MS582906	6-82
EA449414	14-39	EJ430378	14-44	ER430018	13-R3	HZ402390	5-2	MT255420	2-5
EA476256	14-38	EJ447603	14-32	ER450786	7-CR1to8	HZ410984	1-11	MT297663	2-8
EA549246	10-2	EJ448075	14-25	ER450786	8-CR1to6	HZ411017	1-21	MT314987	2-24
EA549270	14-6	EJ450573	6-119	ER450797	14-36x	HZ411030	1-28x	MT314987	6-89
EC220151	9-C7	EJ510333	6-125	ER466525	12-R1	HZ411074	1-20x	MT317441	2-4
EC220151	13-C2	EJ510333	7-6	ER554861	8-R2	HZ411085	1-19	MT317452	2-11
EC220432	7-C11	EJ510333	14-92	ER554883	8-R1	HZ455962	1-45	MT317463	2-10
EC220678	7-C6	EJ514607	14-91	ER554905	8-R3	HZ455973	1-46	MT325473	2-12x
EC220678	9-C1	EJ563433	14-4	ER558573	14-8x	HZ467010	1-35	MT436860	2-14
EC220994	7-C1	EL295312	14-40	ER563455	10-R4	HZ541170	1-10	MV248117	1-41
EC220994	7-C8	EM558180	14-41	ER565121	8-R4	HZ541181	1-29	MV269965	4-21
EC220994	9-C17	EO244012	9-L2	ER589375	14-7x	HZ542092	1-51	MV270066	5-15
EC220994	10-C7	EO346230	10-L1	ES316923	5-3	HZ547751	1-39	MZ217697	6-35
EC250604	10-C8	EO369178	9-L1	ES316934	5-6	HZ548291	1-3	MZ218125	6-73
EC250841	9-C13	EO383365	12-L1	ES375478	6-121	HZ548717	1-2	MZ219576	6-126x
EC250841	12-C4, 5	EP344136	7-RL1	ES436983	14-35	HZ579126	15-9x	MZ227340	6-36
EC250885	7-C9	EP563398	14-57	ES443013	14-46	MB527556	2-33	MZ224113	4-9x
EC250918	7-C3, 4	ER211465	9-R25	ES446117	11-SW1, 2	MB527556	6-113	MZ248005	6-15
EC290531	9-C4	ER211667	7-R1	ES446973	14-5	MB541012	4-20	MZ248016	6-14
EC316113	8-C2, 3	ER211667	7-R5	ES479485	5-18	MC554826	6-112	MZ253113	4-10
EC320051	9-C2	ER211667	7-R15	ES494302	12-SW1	MH244710	4-8	MZ254182	3-6
EC320051	9-C8	ER211667	10-R8	ES496642	9-SW1	MH247533	6-21	MZ256814	5-35x
EC320051	9-C15	ER211667	13-R2	ES546794	6-98	MH248343	4-23	MZ260662	6-71
EC320051	10-C2	ER211757	7-R10	ES562465	6-100	MH254160	3-5	MZ296256	4-6
EC320051	10-C10	ER211757	10-R10	ES563387	14-56	MH273036	4-13	MZ314605	6-38
EC324516	10-C5	ER211858	9-R24	ET398711	7-TR1to4	MH273047	4-16	MZ314673	6-59
EC329771	9-C5	ER212174	9-R22	ET398711	12-TR1,2	MH273295	6-27	MZ314897	4-11
EC329771	9-C9	ER212264	7-R11	ET453486	7-TR5	MH314280	14-70	MZ314998	2-25
EC329771	10-C4	ER212264	7-R13	ET453486	9-TR3,4	MH316304	3-7	MZ314998	6-90
EC329850	10-C1	ER212264	7-R16	ET453486	10-TR2,3	MH317046	5-21	MZ315000	2-27
EC329872	11-C13to16	ER212264	9-R18	ET495371	13-TR1	MH317373	2-20	MZ315000	6-92
EC331705	9-C14	ER212264	10-R14	ET517263	9-TR1, 2	MH317373	6-29	MZ316293	3-4
EC336115	13-C3	ER212477	7-R4	ET517263	10-TR1	MH548335	14-51	MZ316451	6-106
EC336126	10-C3	ER212477	9-R5	EV464207	9-VR1	MH548493	14-83x	MZ316708	6-2
EC350987	8-C1	ER212883	7-R3	EV476223	14-49	MI296245	4-2	MZ316710	6-3
EC357827	9-C6	ER212883	7-R6, 7	EV538402	10-VR1	ML226080	5-30	MZ316822	1-50
EC379168	11-C9to12	ER212883	7-R12	EW315448	14-18x	ML226124	5-33	MZ316945	5-7
EC379203	11-C5to8	ER212883	9-R20,21	EW524845	14-19x	ML226258	6-50	MZ316956	5-9
EC383501	7-C2	ER212883	10-R1	EW540112	14-17	ML228868	6-75	MZ317024	5-23
EC391498	7-C5	ER212883	10-R12	EZ225180	14-26x	ML314684	6-45	MZ317068	5-27
EC391498	7-C7	ER212883	12-R2	EZ246936	14-16x	ML314763	6-60	MZ317340	6-20
EC392016	11-C1to4	ER304402	10-R13	EZ382263	14-15	ML314842	6-65	MZ317406	2-32
EC399565	9-C10	ER304402	12-R3	EZ437736	1-23x	ML314864	6-67	MZ317406	6-114
EC435655	12-C2	ER306843	10-R3	EZ449471	14-42x	ML314932	6-77	MZ405483	5-16
EC435690	9-C20	ER306843	13-R1	EZ544320	7-2	ML314954	6-85	MZ439525	4-25
EC442056	6-54	ER315213	14-29x	EZ548302	14-34	ML314976	2-22	MZ446635	4-7
EC450055	7-C10	ER315944	12-R4, 5	EZ548313	14-24	ML314976	6-87	MZ544331	6-43
EC450055	10-C9	ER324808	8-R6	EZ548324	14-31	ML316394	6-102	MZ544331	7-4
EC450055	12-C3	ER336442	7-R2	EZ548357	11-2	ML316427	6-104	MZ544342	8-2
EC450527	10-C11	ER336442	7-R8	EZ548381	11-9	ML334506	6-64	MZ544364	5-17

INDEX

Parts No.	Ref. No. & Symbol No.	Parts No.	Ref. No. & Symbol No.	Parts No.	Ref. No. & Symbol No.	Parts No.	Ref. No. & Symbol No.	Parts No.	Ref. No. & Symbol No.
MZ548728	6-110	ZS323728	13-2x	ZW260087	6-76	ZW563218	1-52		
SA377190	15-39	ZS325495	15-14x	ZW260144	6-17x	ZW861344	6-16x		
SB425777	6-51	ZS344463	6-97x	ZW260368	14-27				
SB544454	15-12	ZS345914	1-25	ZW270088	2-9				
SC544533	15-5	ZS355511	15-13x	ZW270088	6-103x				
SC544544	15-10	ZS356804	15-27x	ZW270088	11-7x				
SE528906	15-4	ZS365973	2-17	ZW270088	14-65x				
SE544601	15-17	ZS371856	5-19	ZW270101	11-5				
SE548774	14-105	ZS372025	14-14	ZW270123	1-38				
SE548774	15-2	ZS373577	4-5x	ZW270134	3-21				
SE548785	15-20	ZS379405	14-37	ZW270134	14-97				
SE548921	14-104	ZS403301	1-14	ZW272722	14-33x				
SE548921	15-1	ZS413155	1-4	ZW273688	1-55				
SK314100	15-26	ZS413155	6-44	ZW273688	6-34x				
SK425158	15-28	ZS413155	7-5x	ZW273756	1-7				
SK442765	15-31	ZS413155	11-8	ZW273756	4-27x				
SK476684	15-24	ZS413155	14-48	ZW273756	5-5x				
SK543857	6-10	ZS413155	15-6x	ZW273756	6-49x				
SK548662	15-30	ZS413201	4-14	ZW273756	14-11x				
SM548673	15-11	ZS413201	5-14	ZW273756	14-74x				
SP548807	15-35	ZS413201	6-22x	ZW273778	1-16				
SP548818	15-36	ZS413212	6-40	ZW273778	2-13x				
SP548820	15-42x	ZS413223	6-42	ZW273778	14-20x				
SP548932	15-3	ZS413728	5-8x	ZW273778	14-79x				
SP548954	15-15	ZS413728	6-124	ZW273802	1-6x				
SZ457975	15-16	ZS413785	2-19	ZW273802	5-4x				
SZ529108	3-20	ZS414033	1-44	ZW273892	14-71x				
SZ529108	14-96	ZS414044	6-23x	ZW273914	4-15				
SZ544465	14-102	ZS417137	1-59	ZW274026	6-25x				
SZ544476	14-98	ZS417137	2-26x	ZW290283	2-30				
SZ544691	14-103	ZS417137	6-91x	ZW290283	3-18x				
SZ548594	14-99	ZS417148	6-101	ZW290283	5-13				
SZ548605	14-101	ZS417150	3-15	ZW290283	5-32				
SZ548616	14-107	ZS421806	6-28x	ZW290283	6-7				
SZ548897	15-18x	ZS424056	2-18	ZW290283	6-18x				
UM388348	14-88x	ZS424056	3-8	ZW290283	6-62				
UM494267	14-108	ZS424056	4-22x	ZW290283	6-131				
UM494414	14-64x	ZS424056	5-24	ZW290283	11-11				
ZG217337	3-14	ZS425788	6-53	ZW290283	14-82x				
ZG217394	3-16x	ZS425788	15-19x	ZW290294	6-117				
ZG217394	6-129	ZS425981	2-28x	ZW314728	6-52x				
ZG225516	5-22	ZS425981	6-39	ZW314943	6-84x				
ZG226697	6-74	ZS425981	6-93	ZW316800	1-33				
ZG227564	5-28	ZS425981	14-100	ZW316800	1-53				
ZG255633	2-7	ZS427026	3-10	ZW322525	6-6x				
ZG260706	6-116	ZS427037	3-2	ZW322525	11-4				
ZG301061	6-107	ZS427048	6-99	ZW326463	1-42				
ZG314706	6-46	ZS437545	5-34	ZW330412	6-55x				
ZG314818	6-63	ZS439514	4-26x	ZW330423	6-56x				
ZG315011	2-29	ZS442585	11-12	ZW330434	6-57x				
ZG315011	6-94	ZS442585	14-60x	ZW330445	6-58x				
ZG316732	6-5	ZS444273	6-122	ZW357164	14-63x				
ZG316765	6-12	ZS447772	7-3	ZW364803	1-37				
ZG317114	1-36	ZS447772	8-3	ZW376402	5-11x				
ZG317496	2-15	ZS447772	14-22x	ZW392681	4-12				
ZG317777	1-60	ZS447772	14-30	ZW393232	4-18				
ZG396538	1-24	ZS447772	15-22x	ZW408418	15-7				
ZG431291	14-78	ZS455231	1-26	ZW413267	6-32x				
ZG437253	6-19	ZS462925	14-90x	ZW413278	6-26x				
ZG455692	6-83	ZS464692	1-54	ZW413280	4-17				
ZG548403	11-6	ZS482815	15-38x	ZW413998	4-19				
ZG548447	14-77	ZS487776	15-41x	ZW416698	2-21x				
ZS200384	1-9x	ZS498273	15-43x	ZW416698	4-24x				
ZS200384	14-106x	ZS554916	1-47	ZW416698	5-25				
ZS201183	14-10	ZS554962	1-34	ZW416698	6-30x				
ZS201475	1-13	ZS558101	1-61	ZW416698	6-80				
ZS201508	1-22	ZS558134	1-48	ZW416698	14-72x				
ZS202116	6-72	ZS559045	5-20x	ZW419646	6-11				
ZS203016	3-19	ZS563308	15-8	ZW419646	15-40x				
ZS207314	6-69x	ZS563321	15-34	ZW419826	6-66				
ZS207314	6-109	ZS563332	6-111x	ZW432347	6-48x				
ZS217877	6-105	ZS563444	11-13	ZW432347	15-23x				
ZS207314	14-76	ZW231805	1-40	ZW432944	6-8				
ZS253405	15-25x	ZW259705	6-68x	ZW447208	4-4				
ZS272395	3-9	ZW259885	6-70x	ZW461610	15-37x				
ZS314717	6-47	ZW259942	5-10x	ZW526577	15-21				
ZS314717	14-73x	ZW259975	6-79x	ZW548010	15-33				
ZS323728	2-31x	ZW260010	6-108x	ZW548370	11-10				
ZS323728	5-26x	ZW260054	3-17x	ZW548548	14-62x				
ZS323728	6-37	ZW260054	6-130	ZW554624	14-28				

SECTION 3

SCHEMATIC DIAGRAM

1. 202D-SS SCHEMATIC DIAGRAM

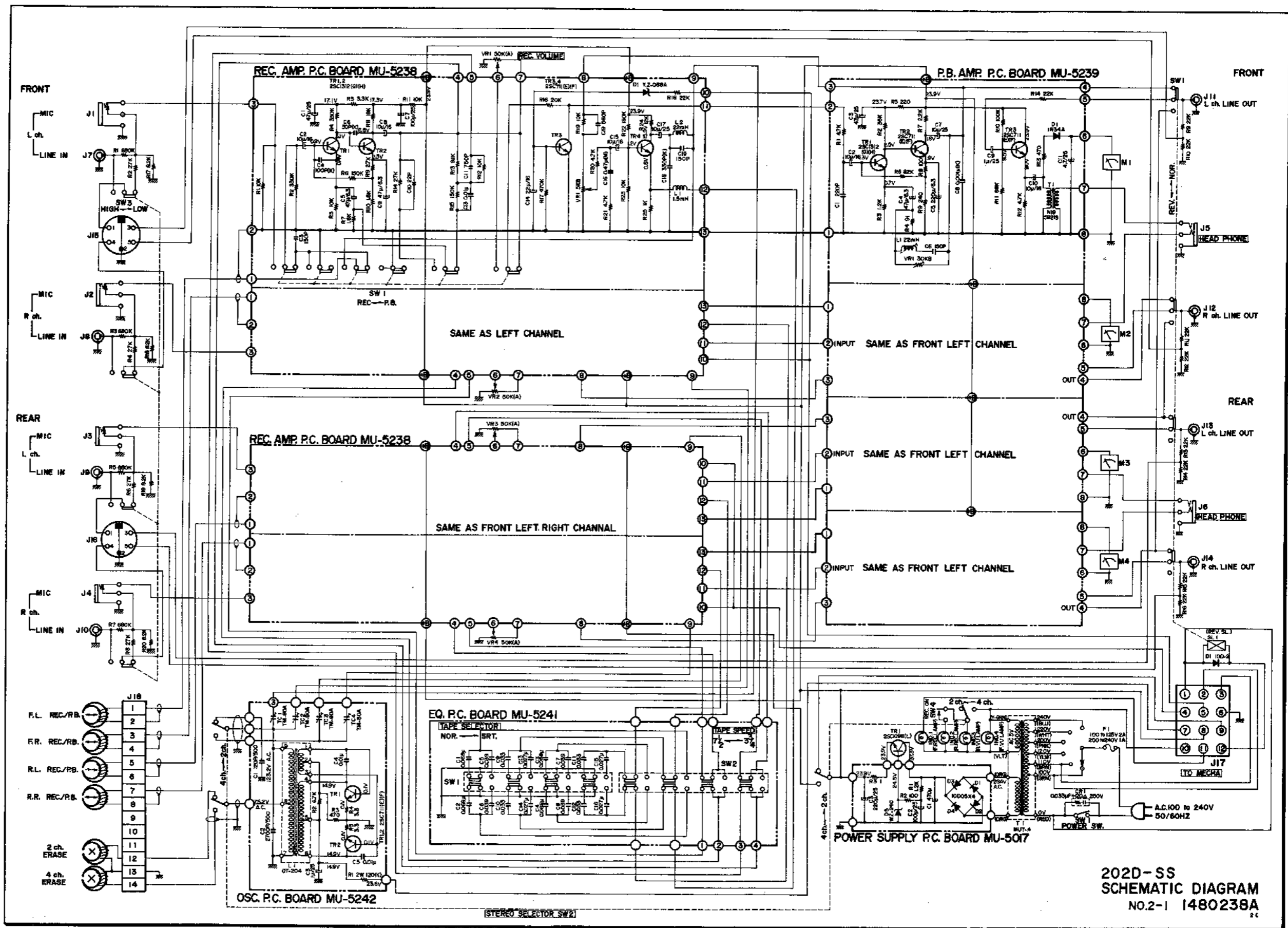

202D-SS
 SCHEMATIC DIAGRAM
 NO.2-1 1480238A
 2C

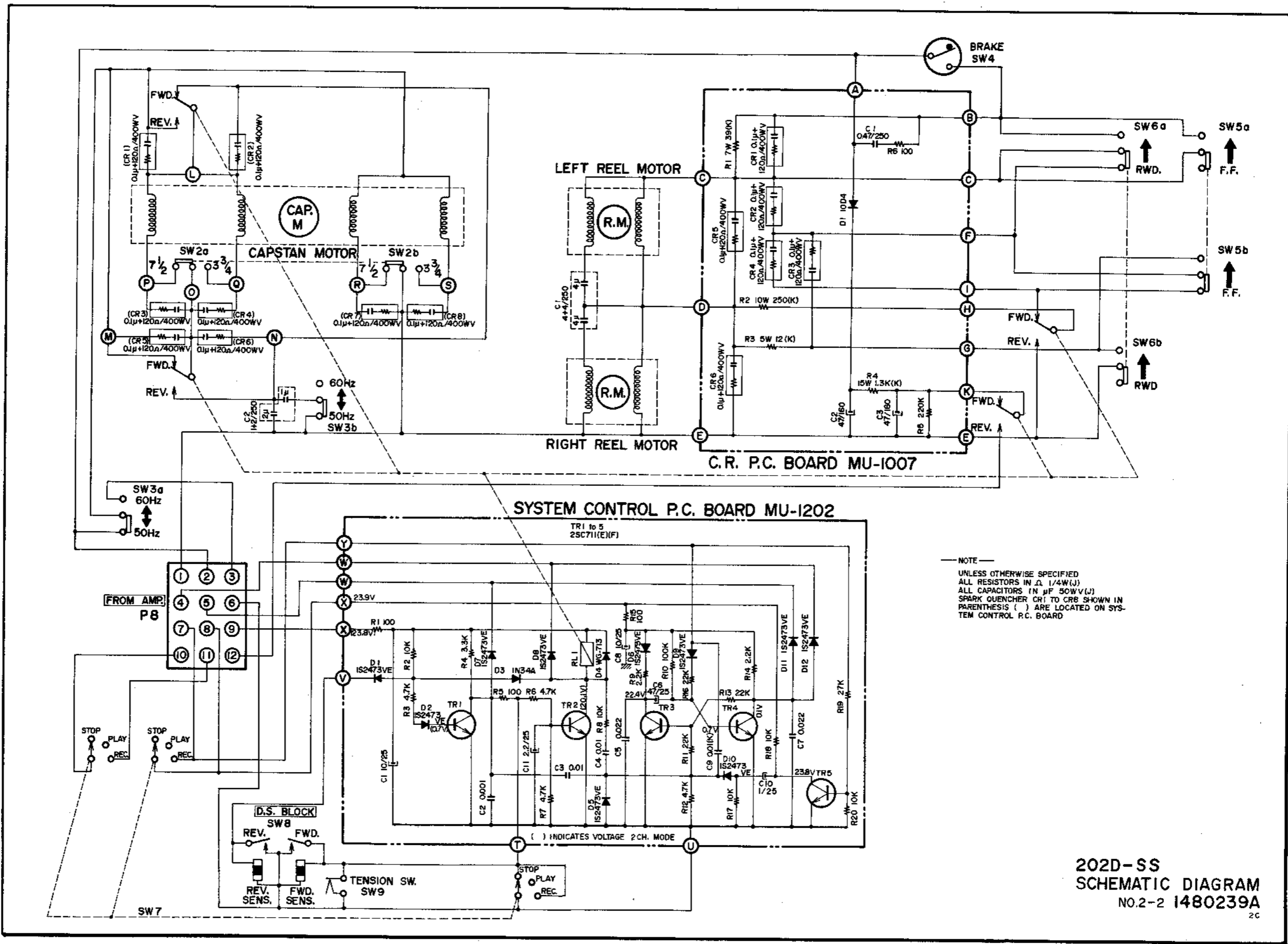

NOTE
 UNLESS OTHERWISE SPECIFIED
 ALL RESISTORS IN () 1/4W (U)
 ALL CAPACITORS IN () 50WV (U)
 SPARK QUENCHER CR1 TO CR6 SHOWN IN
 PARENTHESIS () ARE LOCATED ON SYSTEM
 CONTROL P.C. BOARD

202D-SS
 SCHEMATIC DIAGRAM
 NO.2-2 1480239A
 2C