

1800-SS

OPERATOR'S MANUAL

4 CHANNEL CARTRIDGE / OPEN REEL
SURROUND STEREO TAPE RECORDER

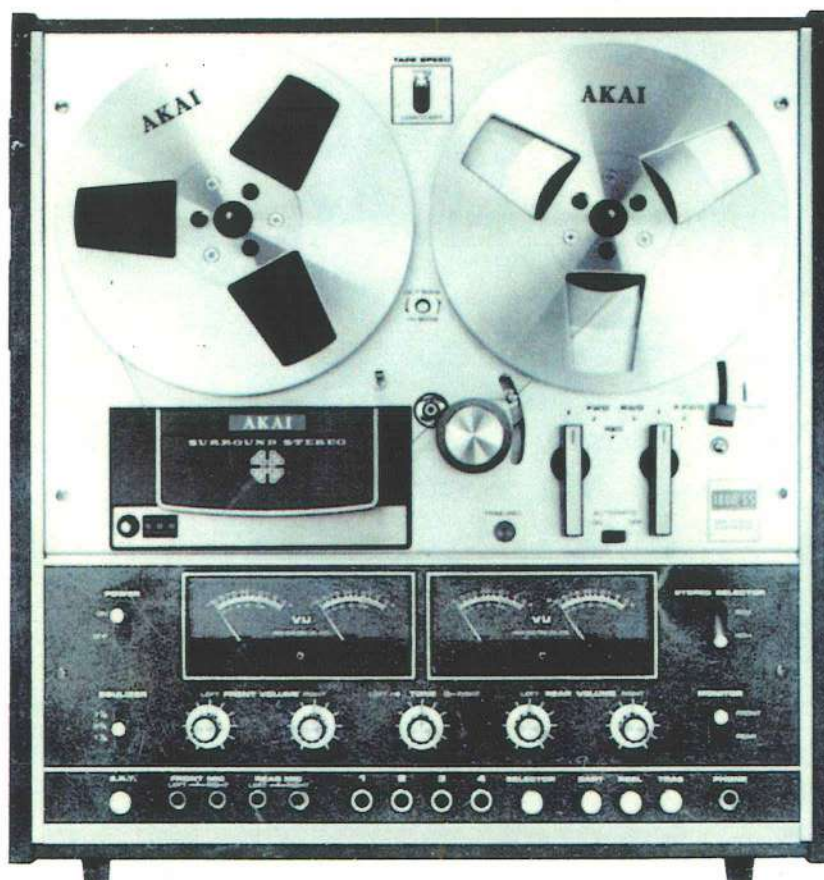

THIS MANUAL IS ALSO APPLICABLE TO MODEL
1800D-SS TAPE DECK.

AKAI[®]

MANUFACTURED & DISTRIBUTED BY AKAI ELECTRIC CO., LTD./AKAI TRADING CO., LTD.

CEE, CSA and UL Standard models are not equipped with a Voltage Selector or Cycle Conversion Switch. Therefore, voltage and cycle conversion is not necessary. If your machine corresponds to any of these standards, please disregard all references to voltage and cycle adjustment throughout this manual.

CEE Models : 220 V, 50 Hz.

CSA Models : 120 V, 60 Hz.

UL Models : 120 V, 60 Hz.

TABLE OF CONTENTS

I. GENERAL INFORMATION		
Specifications	1	
Controls	2	
4-Channel Stereo System	5	
Voltage and Cycle Conversion	6	
Tape Speed Selection	6	
DIN Jacks	6	
Operating Precautions	6	
II. OPERATING INSTRUCTIONS		
4-Track Recording/Playback System	7	
4-Channel Stereo Recording/Playback	7	
2-Channel Stereo Recording/Playback	7	
Playback	8	
4-Channel Surround Stereo Playback	8	
2-Channel Stereo Playback	8	
Fast Forward/Rewind	9	
Automatic Shut-Off	9	
Pause Control	9	
Recording	10	
4-Channel Surround Stereo Recording	10	
2-Channel Stereo Recording	10	
Recording From Other-External Sources	11	
4-Channel Surround Stereo Recording	11	
2-Channel Stereo Recording	11	
Monitoring	11	
Tape Splicing and Editing	11	
Tape Erasing	12	
Head Cleaning		12
Head Demagnetizing		12
One-Micron Gap Head		12
8-Track Recording System		13
Cartridge 8-Track 4-Channel Stereo		3
Cartridge 8-Track 2-Channel Stereo		1
Track Selector (Omit-O-Matic)		13
Remote Control		13
Cartridge Loading		13
8-Track 2-Channel Stereo Playback		14
Automatic Stop/Continuous Play		14
Recording		14
8-Track 4-Channel Surround Stereo		
Recording		14
8-Track 2-Channel Stereo Recording		14
Open Reel Playback		15
4-Channel Surround Stereo Playback		15
2-Channel Stereo Playback		15
Cartridge Playback		16
8-Track 4-Channel Surround Stereo		
Playback		16
8-Track 2-Channel Stereo Playback		16
Transfer from Reel to Cartridge Tape		17
Head Cleaning		17
III. ACCESSORIES		
Standard Accessories		18
Optional Accessories		18

I. GENERAL INFORMATION

SPECIFICATIONS

Track System	Cartridge: 8-track 4-channel/2-channel stereo Reel: 4-track 4-channel/2-channel compatible stereo	Fast Forward/ Rewind Time	Reel: 120/150 sec. using a 1,200 ft. tape at 60/50 Hz
Maximum Reel Capacity	7" Reel	Recording Capacity	Reel: 4-CH stereo (2hrs. 1,200 ft. tape at 1-7/8 ips) 2-CH stereo (4hrs. 1,200 ft. tape at 1-7/8 ips) Cartridge: 4-CH stereo (30 min. 300 ft. cartridge tape) 2-CH stereo (1hr. 300 ft. cartridge tape)
Tape Speed	Reel: 7-1/2, 3-3/4 and 1-7/8 ips ($\pm 1\%$) Cartridge: 3-3/4 ips	Output Jacks	Line (4): 1.23 V ("0" VU)/100 Ω (Required load impedance: more than 20 k Ω) Phone (2): lea. front/rear, 300 to 400 mV/8 Ω (1800D-SS, 30 to 40 mV/8 Ω) Speaker (2): 10 W/8 Ω (1800-SS only)
Wow/Flutter	Reel: Less than 0.12% RMS at 7-1/2 ips Less than 0.15% RMS at 3-3/4 ips Less than 0.20% RMS at 1-7/8 ips Cartridge: Less than 0.25% RMS	Input Jacks	Microphone (4): 0.8 mV/5 k Ω Line (4): 80 mV/300 k Ω
Equalization	Correct equalization for playback of tapes recorded to NAB curve	DIN Jacks	(2) 0.4 V/80 mV (High) 8 mV (Low)
Frequency Response	Reel: 30 to 22,000 Hz (± 3 dB) at 7-1/2 ips 30 to 15,000 Hz (± 3 dB) at 3-3/4 ips 50 to 7,000 Hz (± 3 dB) at 1-7/8 ips Cartridge: 50 to 17,000 Hz (± 3 dB)	Speaker	2-Built-In 4" High Compliance Speakers (1800-SS only)
Distortion	Less than 1.5% (1,000 Hz "0" VU) at 7-1/2 ips	Semi-Conductors	20 Transistors (1800D-SS 20 Transistors) 17 Diodes (1800D-SS 16 Diodes)
Output Power	Reel/Cartridge: 20 W music power (10 W x 10 W) (1800-SS only)	Integrated Circuits	Power IC (2) (1800-SS only) Linear IC (4)
S/N Ratio	Reel: Better than 50 dB Cartridge: Better than 45 dB	Power Supply	100 to 240 V, 50/60 Hz
Erase Ratio	Better than 70 dB	Power Consumption	75 W (1800D-SS 45 W)
Bias Frequency	60 kHz	Dimensions	420(W) x 445(H) x 240(D) mm (16.8" x 17.8" x 9.6")
Heads	Reel: One 4-channel Recording/Playback Head and two Erase Heads (Full track, 2-track) Cartridge: One 4-Channel Recording/Playback Head and one Erase Head	Weight	23 kg (51 lbs.) (1800D-SS 21 kg) (46 lbs.)
Motor	2-Speed induction motor		

*Specification subject to change without notice.

CONTROLS

- TAPE SPEED SELECTOR
- SUPPLY REEL TABLES
- BUILT-IN REEL RETAINER
Locks reel firmly into place
- PINCH WHEEL
Presses against capstan to transport tape
- BUILT-IN 4" SPEAKER (1800-SS ONLY)
- CAPSTAN
Transports tape
- CYCLE CONVERSION SWITCH (A)
"Out" position, 50 Hz ; "In position, 60 Hz
- CAPSTAN POST
- HEAD COVER
Houses Full Track and 2-Track Erase Head and Recording/Playback Head
- FRONT CHANNEL VU METERS (LEFT/RIGHT)
Indicates Front Channel recording/playback levels
- INDEX COUNTER AND RESET BUTTON
- POWER SWITCH
- FRONT CHANNEL VOLUME CONTROLS (LEFT/RIGHT)
- EQUALIZER SWITCH
Set to correspond with reel tape speed
- REAR CHANNEL MICROPHONE JACKS (LEFT/RIGHT)
- FRONT CHANNEL MICROPHONE JACKS (LEFT/RIGHT)
- S.R.T. BUTTON
Depress when using AKAI Super Range Tape or other make low noise tapes
- CARTRIDGE PROGRAM INDICATOR LAMPS
Shows which program is being played (recorded)
- CARTRIDGE PROGRAM SELECTOR

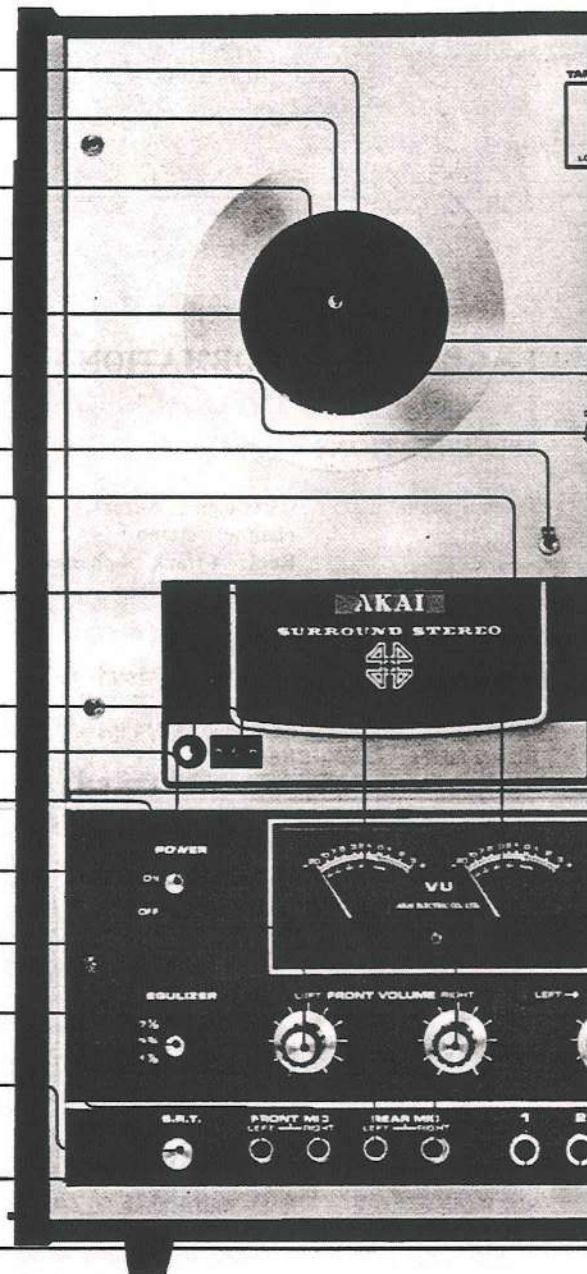

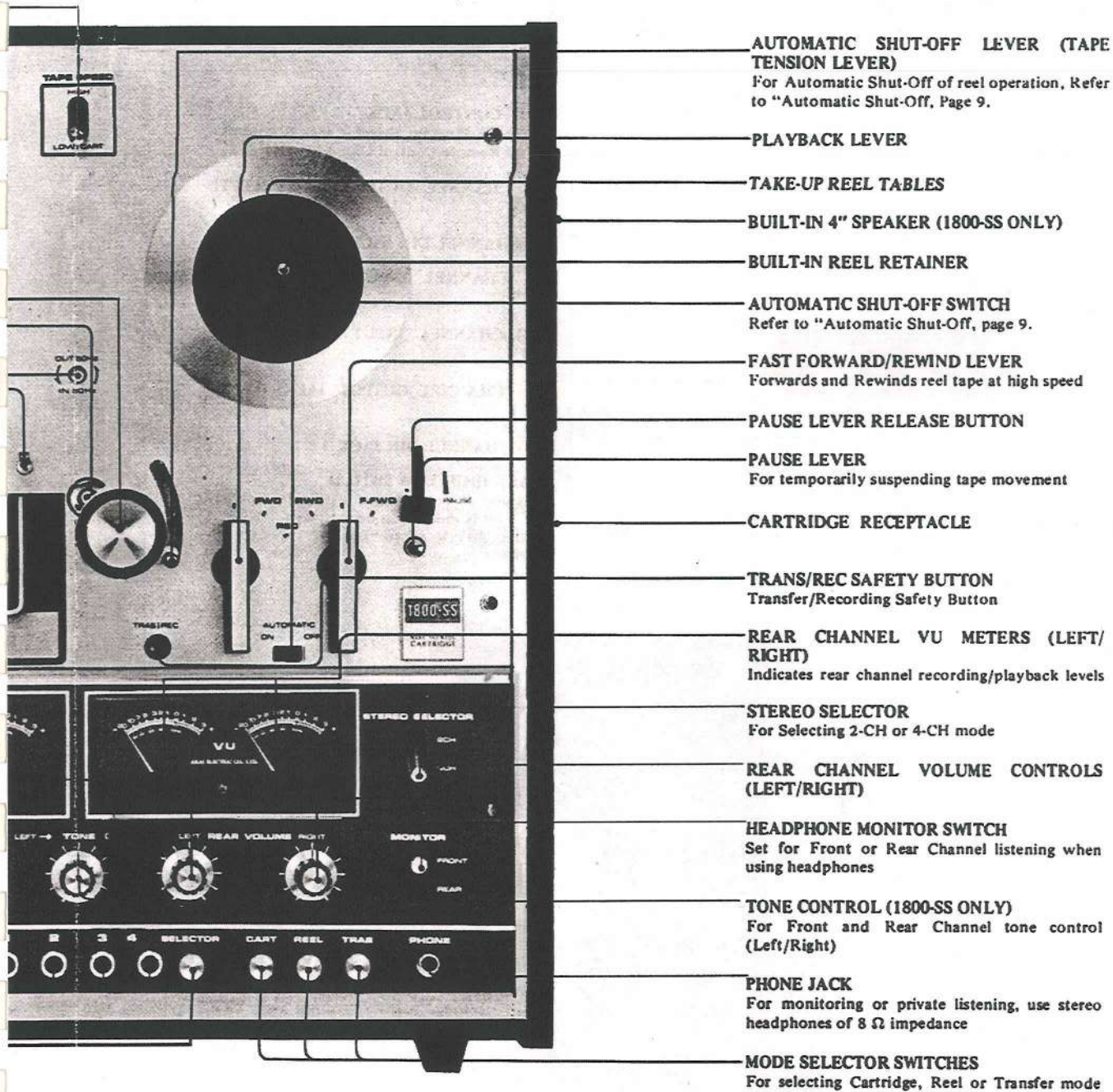

Fig. 1

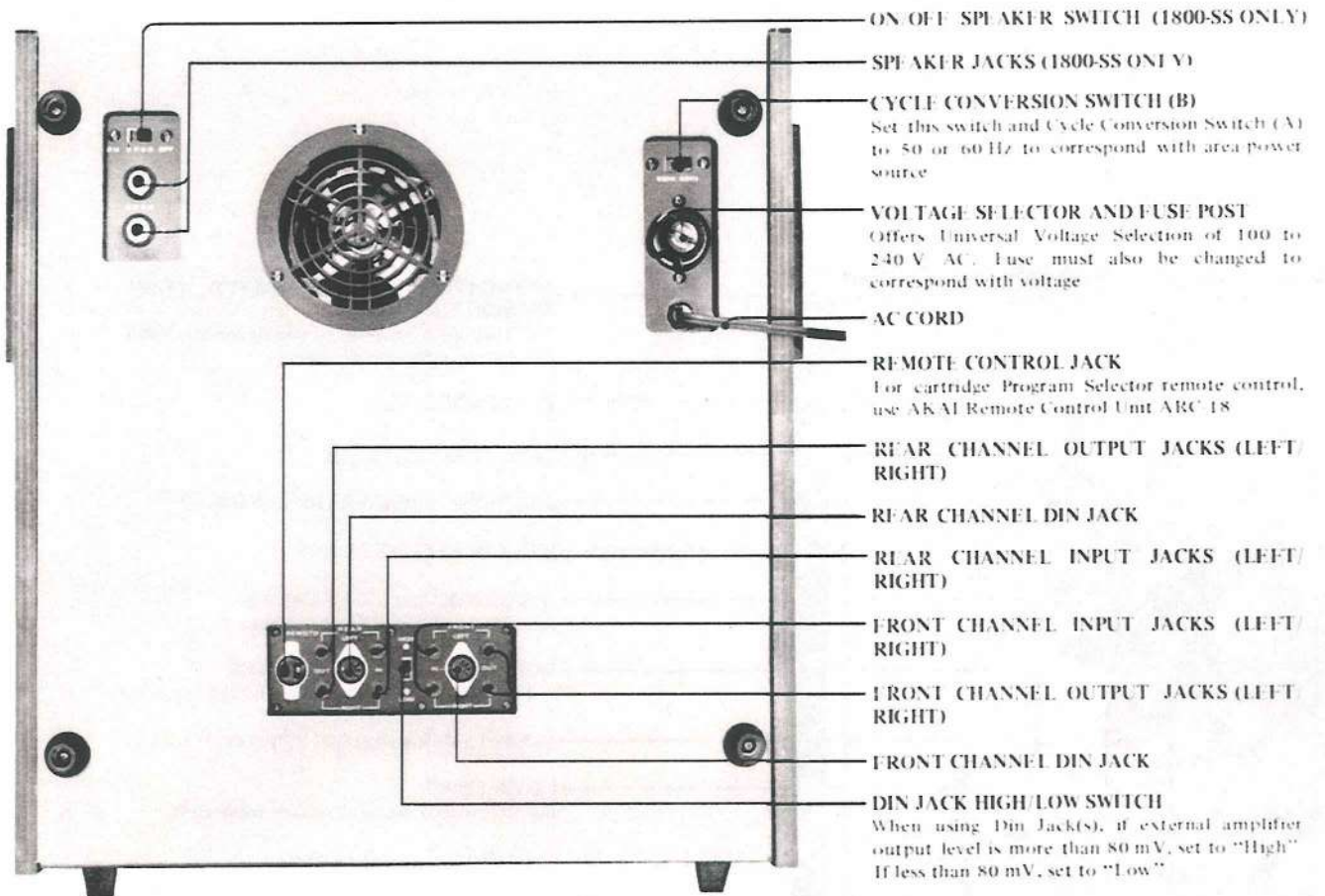

Fig. 2



Fig. 3

4-CHANNEL STEREO SYSTEM

■ 4-CHANNEL STEREO

In the continued pursuance of more aesthetical sound, another stereo revolution has taken place . . . A new stereo "break-through" from 2-channel to 4-channel stereo.

This "move-up" to 4-channel stereo is equally as great an achievement as the advancement from monaural to 2-channel stereo. Just as 2-channel stereo sound reproduction meant the exodus of flat monaural sound, this epoch-making new system eliminates the inability to pick up and reproduce pure concert hall sound. New 4-channel stereo uses 4 signal paths or sound tracks in the program material and in playback approximates the complexity of the sound waves which reach the listener's ear when attending a live concert hall performance.

For playback, 4 speakers are positioned to surround the listener. The sound from the front and rear speakers give the listener an exciting "sense of presence". With the 4 speakers each delivering separate sound, left & right in front and left & right in back of you, you are literally surrounded with a wall of sound which fills the "hole in the middle". This 4-dimensional musical reproduction makes conventional 2-channel stereo seem empty and insufficient.

■ AKAI "SURROUND STEREO"

World-wide exhibitions of AKAI's 4-Channel Surround Stereo are being termed by the listeners as "SENSATIONAL". AKAI's surround stereo supplements conventional stereo's 2 front speakers with 2 additional rear speakers to form the "2-2 System". The listener is surrounded by two sets of speakers (left & right front and left & right rear). This arrangement does not mean, however, that simply adding two speakers to a 2-channel system is all that is necessary for 4-channel playback. At recording time, 4 microphones are used and sound is picked up from 4 separate places. Four separate recordings are made using 4 separate channels (all four tracks in one direction). This 4-channel stereo tape feeds into 4 preamplifiers and 4 main amplifiers to activate a 4-speaker system. Thus, at playback time, sounds from separate channels are emitted from each speaker, providing the listener with a feeling that he is listening to concert hall music from the best seat in the auditorium.

If you are a jazz fan, for instance, you can record and position the speakers for playback so that the spine-tingling sax sounds are emitted from the left front speaker, drums from right front, piano from left rear, and bass from right rear. This arrangement gives the listener a real "sense of presence" creating an atmosphere in which you have the feeling of being exactly in the middle of the live performance.

Further, AKAI has pushed forward just another step and extended 4-Channel Surround Stereo to this combination Open Reel/Cartridge model. AKAI's combination models are the only ones of their kind in the world. This extension to 4-channel stereo means 4-channel open reel or cartridge as well as 4-channel transfer from open reel to cartridge tape. All of these features are compatible with 2-channel stereo as well.

VOLTAGE AND CYCLE CONVERSION

■ VOLTAGE

Model 1800-SS is operable anywhere in the world. With the built-in step-down power transformer, the operator can easily readjust the recorder to any one of six stages of power voltage from 100 to 240 V AC. The operator is requested to check the previously set voltage prior to operation. If readjustment is necessary, please proceed as follows :

1. Remove the FUSE POST by turning counter-clockwise. Reset Voltage Selector Plug to correspond with area voltage.
2. The VOLTAGE SELECTOR is a rotatable plug-in type offering six selections (100/110/120/200/220/240 V).
3. Change fuse according to voltage :
100 to 120 V - 2 A 125 V Fuse
200 V to 240 V - 1 A 250 V Fuse

Caution : Be sure to disconnect the power cord before attempting to readjust voltage. To maintain optimum performance and to prolong the life of your machine, it is important that the line voltage be held within 10% deviation of standard area voltage.

■ CYCLES

Correct tape speed cannot be obtained if the Cycle Conversion Switches are not properly positioned.

1. With a screw driver, turn Switch (A) on face panel counter clockwise about 1/8 of a turn, and move the switch IN or OUT for 60 or 50 cycle operation according to area power source. The switch must be rotated back to its original position after it has been reset.
2. Cycle Conversion Switch (B) at rear of recorder must also be reset accordingly.

Caution : Do not attempt to rotate the Cycle Conversion Switches when the motor is NOT running.

TAPE SPEED SELECTION

Model 1800-SS operates on 3 tape speeds, 7-1/2, 3-3/4, and 1-7/8 ips. Correct tape speed is obtained by operating the Tape Speed Switch and Equalizer and by changing the capstan.

- 7-1/2 ips Set Tape Speed Switch to "HIGH" and set Equalizer to 7-1/2. Mount capstan on capstan shaft and lock into place with notch.
- 3-3/4 ips Set Tape Speed Switch to "LOW" and set Equalizer to 3-3/4. Mount capstan on capstan shaft and lock into place with notch.
- 1-7/8 ips Set Tape Speed Switch to "LOW" and set Equalizer to 1-7/8. Remove capstan (mount on capstan storage post).

Tape Length	RECORDING TIME			
	TAPE SPEED			
	4-Track 4-Channel		4-Track 2-Channel	
	9.5 cm/sec. (3-3/4 ips)	19 cm/sec. (7-1/2 ips)	9.5 cm/sec. (3-3/4 ips)	19 cm/sec. (7-1/2 ips)
1,200 ft.	1 hour	0.5	2	1
1,800 ft.	1.5	0.75	3	1.5
2,400 ft.	2	1	4	2

Fig. 4

DIN JACKS

The DIN Jacks provided at the rear of the recorder are for use in interconnecting Model 1800-SS with an external stereo amplifier. This system enables easy recording or playback through an external amplifier as the complex connection or disconnection of 4 separate plugs is not necessary. Two DR-111 Connection Cords have been included in the standard accessories for your convenience. The DIN Jacks are also equipped with a High/Low Input Switch. When recording from an external amplifier, if the output level of the amplifier is more than 80 mV, set High/Low Input Switch to "HIGH". If less than 80 mV, set to "LOW".

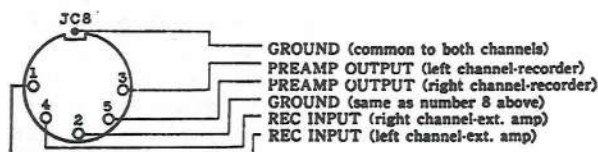

Front View of DIN JACK

Fig. 5

OPERATING PRECAUTIONS

Model 1800-SS is constructed of the finest materials and with proper care will bring you many, many hours of musical listening pleasure. We, therefore, strongly urge you to read this manual thoroughly before attempting operation. The conditions listed below do not indicate failure of your unit. If your machine exhibits any of these conditions, check for the following :

Loss of sensitivity and tone quality

- (A) Dirty erase head.
- (B) Dust adhering to recording/playback head.
- (C) A.C. power lower than the voltage to which your machine is adjusted.

Machine will not record or play

- (A) Check positions of controls, input/output connections and plugs.

Irregularity in tape transport

- (A) Grime adhering to the heads.
- (B) Oil on capstan.
- (C) Sticky or dirty tape surface.
- (D) Bent reels.
- (E) Improperly loaded tape.

Notes :

1. If sound sources are so far away from the microphones that the Volume Controls must be turned up to maximum, some hum or noise will inevitably be recorded. A test recording is recommended before attempting a final recording.
2. If your machine should need service, kindly take it to your nearest authorized AKAI Service Station or inquire at our service department : 12-14, 2-Chome, Higashi-Kojiya, Ohta-Ku, Tokyo, Japan.

II. OPERATING INSTRUCTIONS

4-TRACK RECORDING/PLAYBACK SYSTEM

The AKAI 1800-SS employs a 4-track system which can be used for either 4-channel or 2-channel stereo recording/playback. Tracks are selected by operating the STEREO SELECTOR.

■ 4-CHANNEL STEREO RECORDING/PLAYBACK

4-channel stereo recording/playback requires the simultaneous use of all 4 tracks in one direction. Set Stereo Selector to "4-CH" and follow 4-channel Playback Procedure.

4-track 4-channel stereo tape

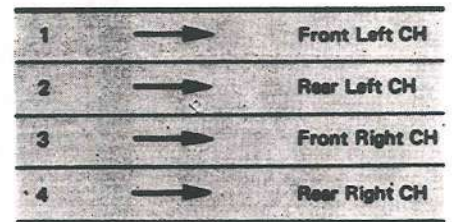
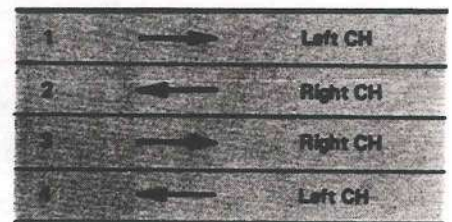

Fig. 6

■ 2-CHANNEL STEREO RECORDING/PLAYBACK

2-channel stereo recording/playback requires the simultaneous use of two tracks. Set Stereo Selector to "2-CH" and use front channel controls. The first stereo recording/playback takes place on tracks 1 and 3, and the second on tracks 2 and 4 after the reels have been inverted. (Refer to 2-Channel Playback Procedure).

4-track 2-channel stereo tape



→ Side A ← Side B

Fig. 7

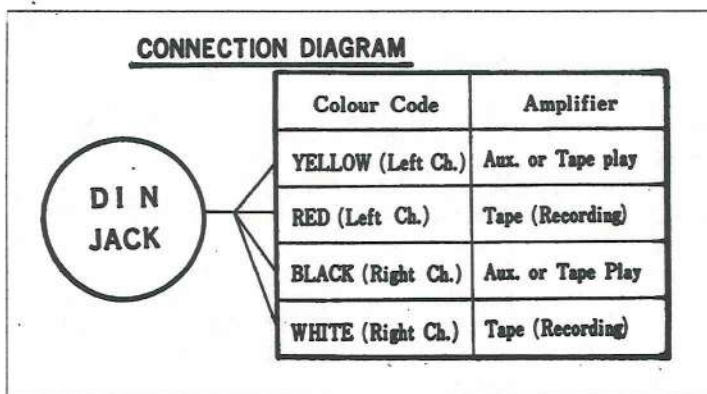

PLAYBACK

(For playback with Model 1800D-SS, refer to page 15.)

Be sure to check the following prior to operation :

- * Heads are clean and free of dust.
- * As tape which has not been used for a period of time may have become sticky, run tape once before using.
- * Tape is loaded properly.



Fig. 8

■ 4-CHANNEL SURROUND STEREO PLAYBACK

Model 1800-SS is equipped with a built-in 2-channel power amplifier. Therefore, a 2-channel power amplifier and an extra pair of speakers are all that is necessary for 4-channel Surround Stereo playback.

If a 2-channel stereo amplifier is used, connect the Front Channel Line Outputs to the Tape Inputs of the external amplifier. Connect a pair of rear speakers to the speaker terminals of Model 1800-SS and another pair of front speakers to the external amplifier.

If two 2-channel stereo amplifiers are used, connect the Front and Rear Channel Line Outputs respectively to both external amplifiers. Connect a pair of speakers to the Speaker Terminals of both external amplifiers and set the Speaker Switch to OFF position.

Connect power cord and load a 4-channel pre-recorded tape as shown in Fig. 8. Lock reels into place with the Reel Retainers provided on Reel Shafts.

- A. Turn on Power Switch.
- B. Set Stereo Selector to "4-CH" position.
- C. Set Mode Selector to "REEL".
- D. Select tape speed (Refer to TAPE SPEED SELECTION, page 6).
- E. Set Speaker Switch to "ON" position.
- F. Set Playback Lever to "FWD" and adjust Speaker Volume Controls and Tone Controls of Model 1800-SS and external amplifier controls.

■ 2-CHANNEL STEREO PLAYBACK

Connect power cord and load a 2-channel pre-recorded tape.

- A. Turn on Power Switch.
- B. Set Stereo Selector to "2-CH" position.
- C. Set Mode Selector to "REEL".
- D. Select tape speed (Refer to TAPE SPEED SELECTION, page 6).
- E. Set Speaker Switch to "ON" position.
- F. Set Playback Lever to "FWD" and adjust Front Channel Volume Controls and Tone Controls.
- G. Invert reels for playback on tracks 2-4.

Important :

The 2-channel internal amplifier automatically switches to rear channel operation when the Stereo Selector is set to "4-CH" position, and to front channel operation when set to "2-CH" position.

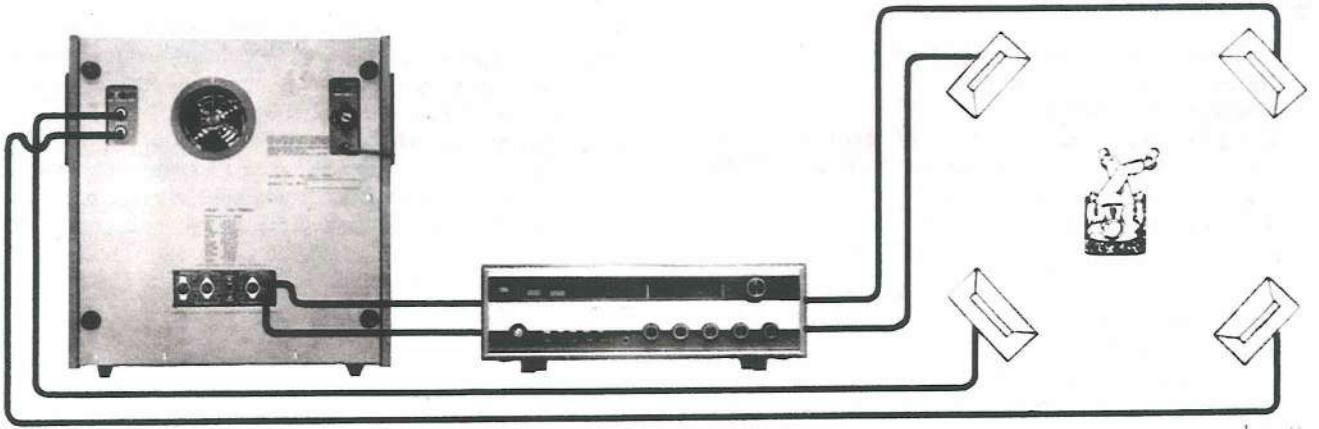

Fig. 9

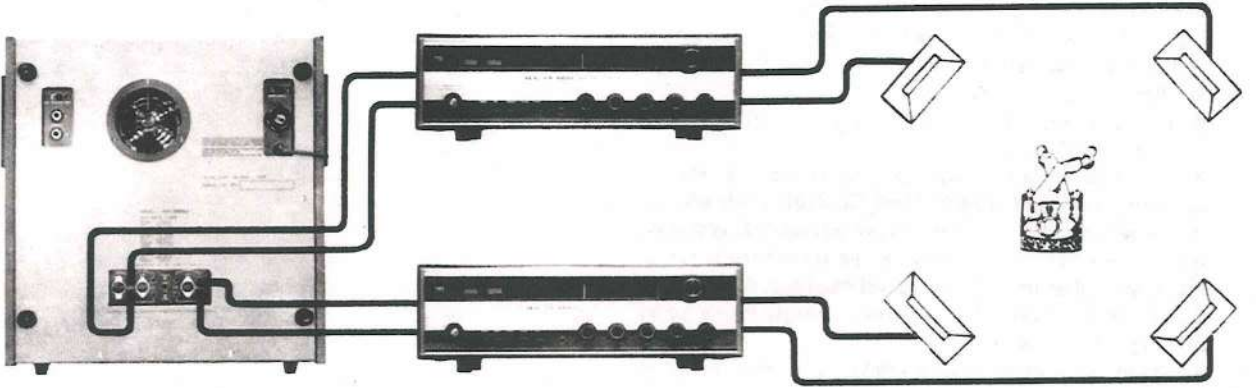

Fig. 10

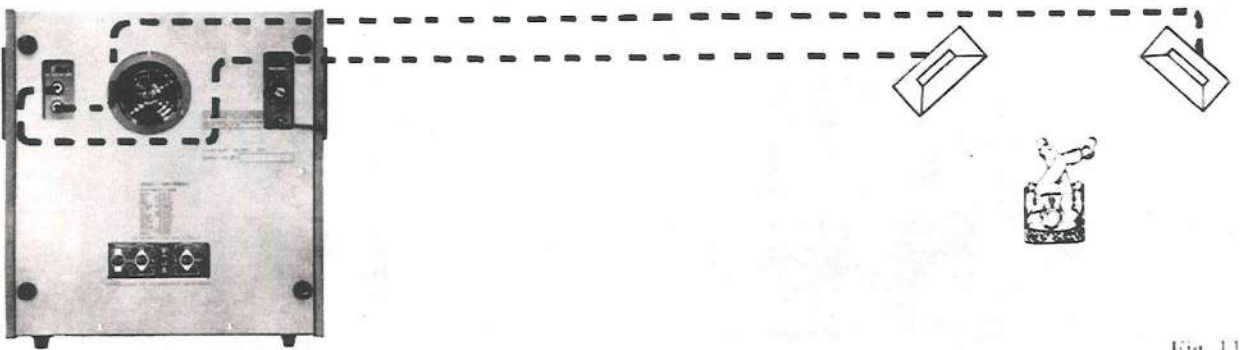

Fig. 11

FAST FORWARD/REWIND

For Fast Forward or Rewind, operate Fast Forward/Rewind Lever. This feature enables rapid selections of recordings on the tape.

AUTOMATIC SHUT-OFF

One of the exclusive features of Model 1800-SS is the Automatic Shut-Off function of the unit. For Automatic Shut-Off, thread tape through Automatic Shut-Off Lever as described in Tape Loading procedure and set Automatic Shut-Off Switch to "ON". When the tape comes to the end or is accidentally broken, the Automatic Shut-Off Lever will drop, cutting off the power of the entire unit.

PAUSE CONTROL

To momentarily stop the tape during playback/recording, set Pause Lever to "PAUSE" position. To re-start, depress Pause Lever Start Button. (Pause Control will not function during Fast Forward or Rewind Mode).

RECORDING

Please be sure to check the following prior to operation.

- * Heads are clean and free of dust.
- * Heads are demagnetized.
- * Use good quality tape (new tape will give best results).
- * As tape which has not been used for a period of time may have become sticky, run tape once before using.
- * Tape is properly loaded.

■ 4-CHANNEL SURROUND STEREO RECORDING

Connect Power Cord and load a tape as described in Fig. 12.

- A. Turn on Power Switch.
- B. Set Stereo Selector to "4-CH" position.
- C. Set Mode Selector to "REEL".
- D. Select tape speed (Refer to TAPE SPEED SELECTION, page 6).
- E. With Reset Button, set Index Counter to "000".
- F. Insert Microphone Plugs into Microphone Jacks (front and rear channel left and right).
- G. Set Pause Lever to "PAUSE".
- H. While depressing TRANS/REC Button, set Playback Lever to "REC" position.
- I. Adjust and balance microphone volume levels by operating corresponding Volume Controls while observing corresponding VU Meters (normal recording should not exceed "0" VU on any of the respective meters).
- J. When an optimum recording level has been determined, depress Pause Lever Start Button to release Pause Lever and begin recording.
- K. To stop recording, return Playback Lever to Stop (vertical) position.

Note: There are numerous possibilities for microphone placement. Experiment and position according to your own musical taste.

■ 2-CHANNEL STEREO RECORDING

For 2-channel stereo recording, substitute the following steps for Steps B and F of 4-channel Surround Stereo procedure and add Step M.

- B. Set Stereo Selector to "2-CH" position.
- F. Insert Microphone Plugs into Microphone Jacks (front channel left and right). Maintain a distance of at least 2 meters (7 ft.) between microphones.
- M. Invert reels for recording on tracks 2-4.

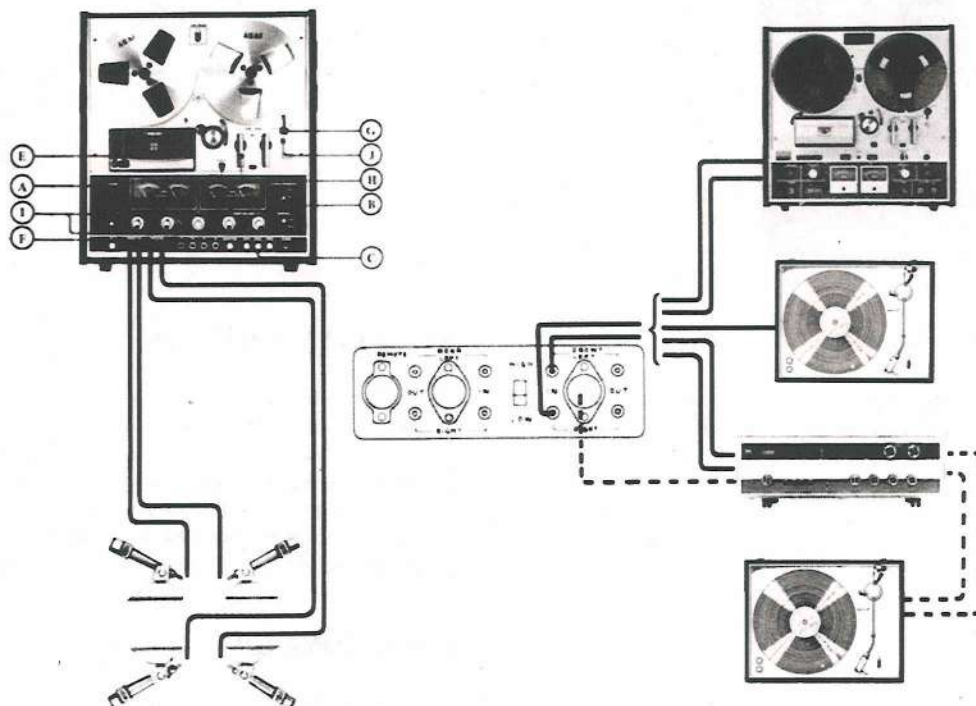

Fig. 12

RECORDING FROM OTHER EXTERNAL SOURCES

■ 4-CHANNEL SURROUND STEREO RECORDING

For 4-channel stereo recording, connect the front & rear channel LINE INPUTS of Model 1800-SS to the front & rear channel OUTPUTS of your 4-channel external source instead of step ⑥ of 4-channel stereo recording procedure.

■ 2-CHANNEL STEREO RECORDING

From an external amplifier (Fig. 12)

Connect the OUTPUT leads of the external amplifier or tuner amplifier to the front channel LINE INPUT JACKS instead of Step ⑥ of conventional 2-channel stereo recording procedure.

From a record player (Fig. 12)

A "crystal pick-up" or a "ceramic pick-up" can be connected directly to the front channel LINE INPUT JACKS instead of Step ⑥ of conventional 2-channel stereo recording procedure. If a "magnetic cartridge" is used, for proper equalization, it must be connected to the Line Input Jacks through an external amplifier.

From another tape recorder (Fig. 13)

For 4-channel Surround Stereo recording, connect the front and rear LINE OUTPUT JACKS of the playback recorder to the front and rear LINE INPUT JACKS of Model 1800-SS instead of Step ⑥ of 4-channel surround stereo recording procedure.

For 2-channel recording, connect the LINE OUTPUT JACKS of the playback machine to the front channel LINE INPUT JACKS of Model 1800-SS instead of Step ⑥ of conventional 2-channel stereo recording procedure.

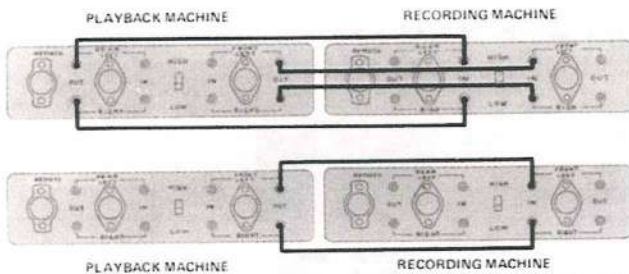

Fig. 13

MONITORING

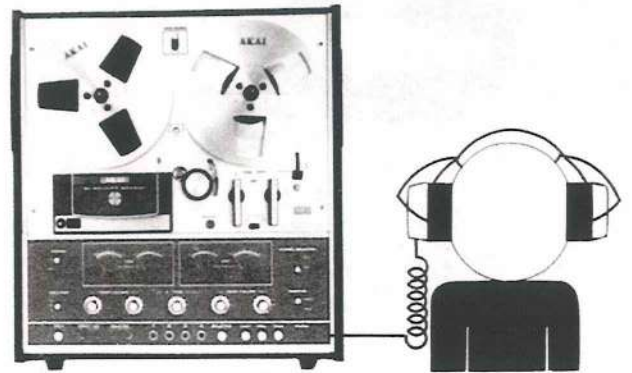

Fig. 14

For monitoring or private listening, connect Stereo Headphones (8 Ω impedance type) to Headphone Jacks and set Monitor Switch for Front or Rear Channel listening.

The Phone Monitor Switch is inter-connected with the Stereo Selector Switch for automatic return to 2-Channel position when the Stereo Selector is switched from 4 to 2-channel position.

TAPE SPLICING AND EDITING

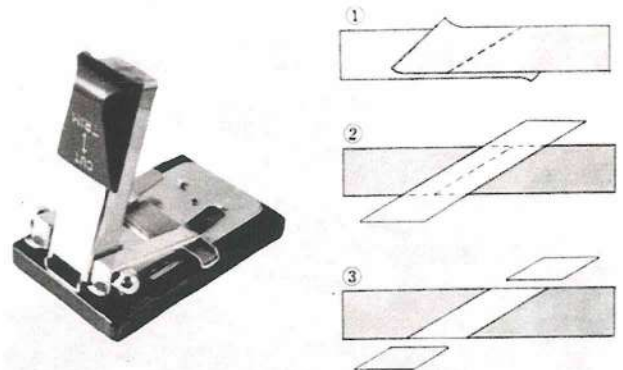

Fig. 15

Cut tape diagonally with an overlap so that the ends are lined up (cutting tape on diagonal eliminates detection of the splice in recording). Cover aligned ends with SPLICING TAPE.

Press firmly, exerting pressure to secure ends evenly. Trim off excess splicing tape (Cut into recording tape very slightly as illustrated by dotted lines. This eliminates the possibility of a sticky splice). Splicing of tape using scissors requires skillful work. With our specially designed PORTABLE SPLICER, splicing can be done very smoothly.

TAPE ERASING



Fig. 16

Any signals previously recorded on the tape will be automatically erased as a new recording is made. For erasing only, load tape and set recorder to recording mode. Model 1800-SS is equipped with separate 2-channel and full track erase heads. For full track erase, set STEREO SELECTOR to "4-CH" position and for 2-Channel erase, set to "2-CH" position. No plugs should be connected to the line input jacks or microphone jacks. For quick and complete erasing, the use of a Bulk Tape Eraser is recommended.



Fig. 17

Tape Oxide/Dust Deposits Cause 90% of Tape Recording Failures

For quality performance it is imperative that tape recorder heads be kept clean at all times. Dust and magnetic particles from the tape tend to deposit on the heads after prolonged use of the recorder. This results in poor head-to-tape contact deteriorating sound quality and sensitivity. Such dust causes drastic drops in recording/playback levels and nullifies high quality sound.

Make it a rule to clean the heads every time you use your recorder. AKAI's Head Cleaning Kit Model HC-500 is recommended for removing foreign matter deposited on the heads.

HEAD DEMAGNETIZING



Fig. 18

Normally the steel pole pieces which form a part of the Recording and Playback Heads become slightly magnetized. The effect of slight head magnetization is that it partially erases the tape, especially at high frequencies. Generally, this condition can be detected by the loss of high frequency response which cannot be corrected through head alignment. Severe magnetization (which may be caused by using magnetized tools in the vicinity of the heads) will result in noise or considerable distortion in addition to the loss of high frequency response. Although Model 1800-SS already has a built-in head demagnetizing circuit, it is recommended that head demagnetizing be performed periodically. This can be accomplished by touching the head lightly with the demagnetizer and making several small circular motions over all heads surface areas as well as the head housing.

Caution:

- A. Operate REC/PB Lever gently (do not return to STOP position abruptly from recording or playback position).
- B. Power should be off while the demagnetization is being effected.

ONE-MICRON GAP HEAD



Fig. 19

The cartridge unit of Model 1800-SS employs AKAI's one-micron gap head for an amazingly important difference in tape recording. It's the difference between ordinary performance and the highest possible quality perfection.

Just what is a one-micron gap head? It's a head with a width of only one astounding micron. Until now two or four micron gap heads have been the standards for comparing tape recorders. However, AKAI has pushed ahead and narrowed the head gap; thus narrowing the difference between tape recording results and actual sound.

8-TRACK RECORDING SYSTEM

■ CARTRIDGE 8-TRACK 4-CHANNEL STEREO

Cartridge 8-Track 4-Channel Stereo Tape		
1		Front Left
2		Front Left
3		Rear Left
4		Rear Left
5		Front Right
6		Front Right
7		Rear Right
8		Rear Right

Fig. 20

For 4-channel stereo operation, four of the 8 tracks are utilized at a time. Recording/Playback track sequence is 1-3-5-7, and 2-4-6-8. When recording/playback on tracks 1-3-5-7 terminates, the second channel (tracks 2-4-6-8) is automatically positioned for continued operation. Because 4 tracks are used simultaneously for 4-channel operation, only 2 programs are recorded or played back on a single tape.

■ CARTRIDGE 8-TRACK 2-CHANNEL STEREO

Cartridge 8-Track 2-Channel Stereo Tape		
1		Left 1
2		Left 2
3		Left 3
4		Left 4
5		Right 1
6		Right 2
7		Right 3
8		Right 4

Fig. 21

For 2-channel stereo operation, two of the 8 tracks are utilized at a time. Recording/Playback track sequence is 1-5, 2-6, 3-7, 4-8. When recording/playback on tracks 1-5 terminates, the second channel (tracks 2-6) is automatically positioned for continued operation, etc. until 4 programs have been recorded or played back.

TRACK SELECTOR (OMIT-O-MATIC)

Model 1800-SS employs a 8 track cartridge stereo system. The tape has a total of 8 tracks, 2 or 4 of which are used at a time for 2 or 4 channel stereo operation. The Track Selector indicates four 2-track stereo channels. However, in the case of 4-channel operation, because 4 tracks are used simultaneously, the Track Selector Omit-O-Matic device functions, utilizing only program channels 1 and 2. Operate Program Selector Button for program selection.

REMOTE CONTROL

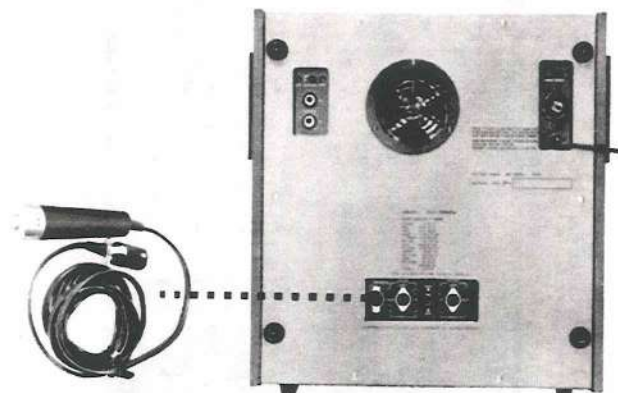

Fig. 22

The Program Selector can be remote controlled with AKAI Remote Control unit ARC-18. Plug into remote control socket on rear panel of recorder.

CARTRIDGE LOADING

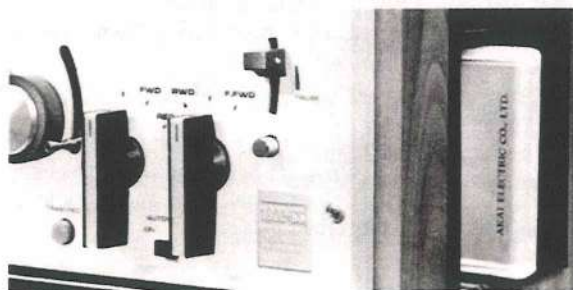

Fig. 23

Insert cartridge, with notch upward, into cartridge receptacle provided on side panel.

8-TRACK 4-CHANNEL SURROUND STEREO PLAYBACK (For playback with Model 1800D-SS, refer to page 16).

For connections, refer to open reel 4-channel surround stereo playback procedure, page 8 .

- A. Turn on Power Switch.
- B. Set Automatic Shut-Off Switch to "OFF".
- C. Set Stereo Selector to "4-CH" position.
- D. Set Mode Selector to "CART".
- E. Set Tape Speed Selector to "CART".
- F. Set Speaker Switch to "ON".
- G. Load a 4-channel pre-recorded tape. When properly positioned, playback will commence.
- H. Adjust Volume Controls and Tone Controls of Model 1800-SS and adjust external amplifier controls.

Note : The Program Indicator Lamps will show which track is being played. Operate Program Selector Button to change program. For 4-channel playback, only Program 1 and 2 Indicator Lamps will operate. At the end of Program 2, the Program Indicator will return to Program 1.

8-TRACK 2-CHANNEL STEREO PLAYBACK (For playback with Model 1800D-SS, refer to page 16).

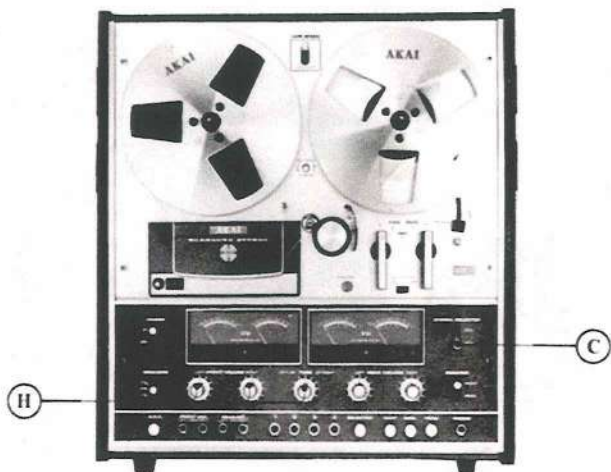

Fig. 24

For 2-channel stereo playback, only the Front Channel is utilized. Substitute the following steps for Steps ③, ④ and ⑤ of 8-Track 4-channel Stereo Playback procedure. (External Speaker Jacks can be used for connecting external speakers).

- C. Set Stereo Selector to "2-CH" position.
- G. Load a 2-channel pre-recorded tape. When properly positioned, playback will commence.
- H. Adjust Front Channel left and right Volume Controls and Tone Controls.

Note : The Program Indicator Lamps will show which track is being played. Operate Program Selector Button to change program. At the end of each program, subsequent tracks are automatically set for continued playback.

AUTOMATIC STOP/CONTINUOUS PLAY

Model 1800-SS is equipped with an Auto Stop/Cont. Play Switch located inside the cartridge receptacle. When the switch is set to "Auto Stop", at the end of program 2 (4-channel) or program 4 (2-channel), the tape will return to channel 1 and stop automatically.

If Continuous Play is desired, set switch to "Cont.Play". (The tape will be played over and over until the recorder is turned off).

Caution : When Automatic Stop has been effected, to re-start tape, set Auto Stop/Cont. Play Switch to "Cont Play" (When cartridge program selector is operated after automatic stop has been effected, the program indicator lamps will light, but play will not resume until the switch has been re-set).

RECORDING

■ 8-TRACK 4-CHANNEL SURROUND STEREO RECORDING

For connections, refer to 4-channel Surround Stereo Recording procedure, page 10.

- A. Turn on Power Switch.
- B. Set Automatic Shut-Off Switch to "OFF" position.
- C. Set Tape Speed Selector to "CART".
- D. Set Stereo Selector to "4-CH" position.
- E. Set Mode Selector to "CART".
- F. Connect source as outlined in open reel 4-channel Surround Stereo recording procedure.
- G. While depressing TRANS/REC Button, set Playback Lever to "REC".
- H. Adjust and balance recording levels by operating Volume Controls while observing VU Meters (normal recording should not exceed "O" VU on any of the respective meters).
- I. When an optimum recording level has been determined, load a cartridge tape. When the cartridge is properly positioned, recording will commence.
- J. To stop recording, return Playback Lever to Stop (vertical) position and remove cartridge tape. (If cartridge tape is not removed, the tape will continue to advance).

Notes :

- 1. Tone Controls of Model 1800-SS have no effect during recording mode.
- 2. The Program Selector should be set to channel 1 before initiating recording operation.
- 3. If Auto Stop/Cont. Play Switch is set to "Auto Stop", upon completion of recording on Program 2, the tape will return to Program 1 and stop automatically. Recording time is 15 minutes per channel (30 min. for 4-channel stereo) using a 300 ft. cartridge tape.
- 4. For optimum performance, only quality tapes should be used. AKAI Cartridge Tapes ACT-200 (200 ft.) and ACT-300 (300 ft.) are highly recommended.

■ 8-TRACK 2-CHANNEL STEREO RECORDING

For 2-channel stereo recording, substitute the following steps for Steps ③, ④ and ⑤ of above 8-Track 4-Channel Surround Stereo recording procedure.

- D. Set Stereo Selector to "2-CH" position.
- E. Connect source as outlined in open reel 2-channel stereo recording procedure.
- H. Adjust and balance recording levels by operating the Front Channel Volume Controls while observing the Front Channel VU Meters (normal recording should not exceed "O" VU on Front Channel (left and right) VU Meters).

Note : If Auto Stop/Cont. Play Switch is set to "Auto Stop", upon completion of recording of Program 4, the tape will return to Program 1 and stop automatically. Recording time is 15 minutes per channel (1 hour using a 300 ft. cartridge tape).

Caution : If Auto Stop/Cont Play Switch is set to "CONT PLAY" during recording mode, continuous recording will take place, erasing previously recorded material.

OPEN REEL PLAYBACK (Model 1800D-SS)

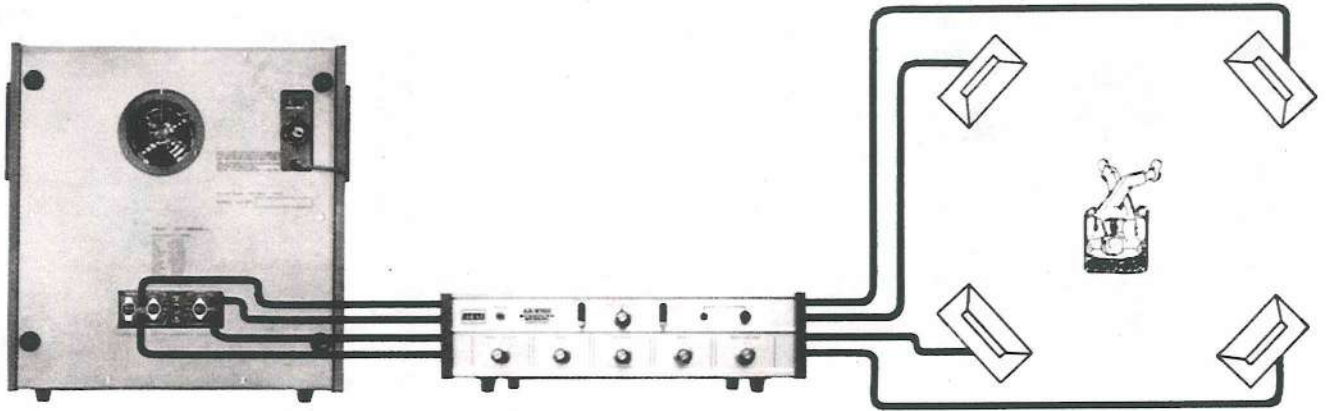

Fig. 25

Be sure to check the following prior to operation.

- * Heads are clean and free of dust.
- * As tape which has not been used for a period of time may have become sticky, run tape once before using.
- * Tape is loaded properly.

■ 4-CHANNEL SURROUND STEREO PLAYBACK

Model 1800D-SS Tape Deck does not include power amplifiers. It is, therefore, necessary to provide a 4-channel external amplifier and 4 speakers for surround stereo playback. Connect Front & Rear Channel Line Outputs to front & rear channel tape inputs of Stereo Amplifier and connect 4 speakers to the amplifier.

Connect power cord and load a 4-channel pre-recorded tape. (For 4-channel Surround Stereo playback using two 2-channel amplifiers, refer to page 8).

- A. Turn on Power Switch.
- B. Set Stereo Selector to "4-CH" position.
- C. Set Mode Selector to "REEL".
- D. Select, tape speed (Refer to Tape Speed Selection, page 6).
- E. Set Playback Lever to "FWD" and adjust Volume Controls of Model 1800D-SS and Volume Controls, etc. of external amplifier.

■ 2-CHANNEL STEREO PLAYBACK

Model 1800D-SS Tape Deck does not include power amplifiers. It is, therefore, necessary to provide an external amplifier and a pair of speakers for playback. In case a 4-channel amplifier is used, utilize only front channel connections. Connect Front Channel Line Outputs to Tape Inputs of external stereo amplifier and connect a pair of speakers to the amplifier. Connect power cord and load a 2-channel pre-recorded tape.

- A. Turn on Power Switch.
- B. Set Stereo Selector to "2-CH" position.
- C. Set Mode Selector to "REEL".
- D. Select tape speed (Refer to TAPE SPEED SELECTION, page 6).
- E. Set Playback Lever to "FWD" and adjust Front Channel Volume Control of Model 1800D-SS and Volume Controls, etc. of external amplifier.
- F. Invert reels for playback on tracks 2-4.

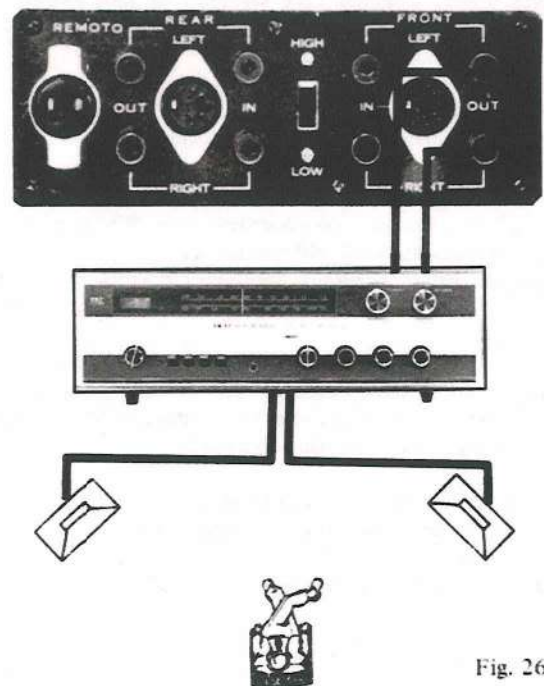

Fig. 26

CARTRIDGE PLAYBACK (Model 1800D-SS)

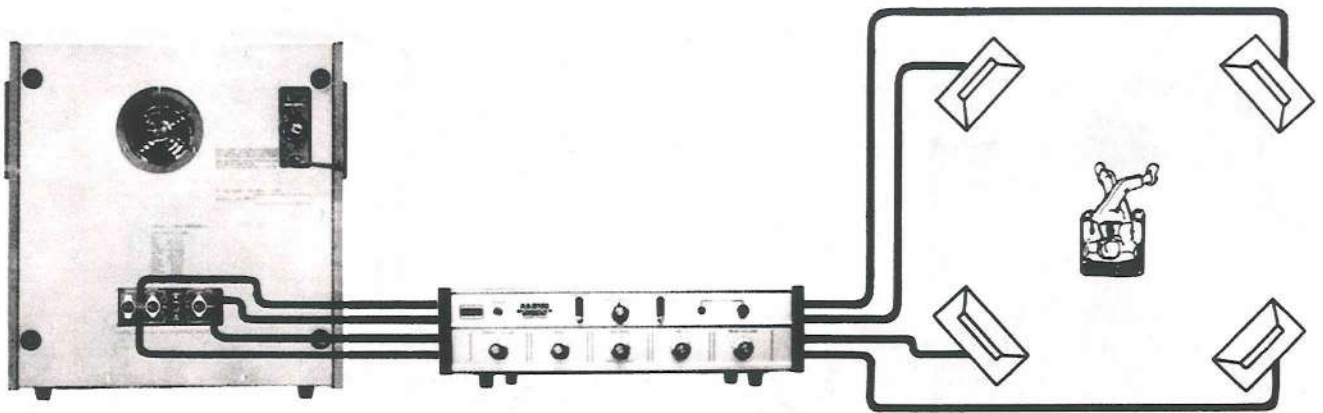

Fig. 27

■ 8-TRACK 4-CHANNEL SURROUND STEREO PLAYBACK

For connections, refer to 4-channel Surround Stereo procedure page 8.

- A. Turn on Power Switch.
- B. Set Automatic Shut-Off Switch to "OFF".
- C. Set Stereo Selector to "4-CH" position.
- D. Set Mode Selector to "CART".
- E. Set Tape Speed Selector to "CART".
- F. Load a 4-channel pre-recorded tape. When properly positioned, playback will commence.
- G. Adjust Volume Controls of Model 1800D-SS and Volume Controls, etc. of external amplifier.

Note : The Program Indicator Lamps will show which track is being played. Operate Program Selector Button to change program. For 4-channel playback, only program 1 and 2 Indicator Lamps will operate. At the end of program 2, the Program Indicator Lamp will return to Program 1.

■ 8-TRACK 2-CHANNEL STEREO PLAYBACK

Model 1800D-SS Tape Deck does not include power amplifiers. It is, therefore, necessary to provide an external amplifier and a pair of speakers for playback. In case a 4-channel amplifier is used, utilize only front channel connections.

Connect Front Channel Line Outputs to tape inputs of external amplifier and connect a pair of speakers to the amplifier.

- A. Turn on Power Switch.
- B. Set Automatic Shut-Off Switch to "OFF".
- C. Set Stereo Selector to "2-CH" position.
- D. Set Mode Selector to "CART".
- E. Set Tape Speed Selector to "CART".
- F. Load a 2-channel pre-recorded tape. When properly positioned, playback will commence.
- G. Adjust Front Channel Volume Controls of Model 1800D-SS and volume controls, etc. of external amplifier.

Note : The Program Indicator Lamps will show which track is being played. Operate Program Selector Button to change program. At the end of each program, subsequent tracks are automatically set for continued playback.

Recording from Other External Sources

Refer to conventional reel recording, page 10.

Monitoring

Refer to Monitoring procedure, page 11.

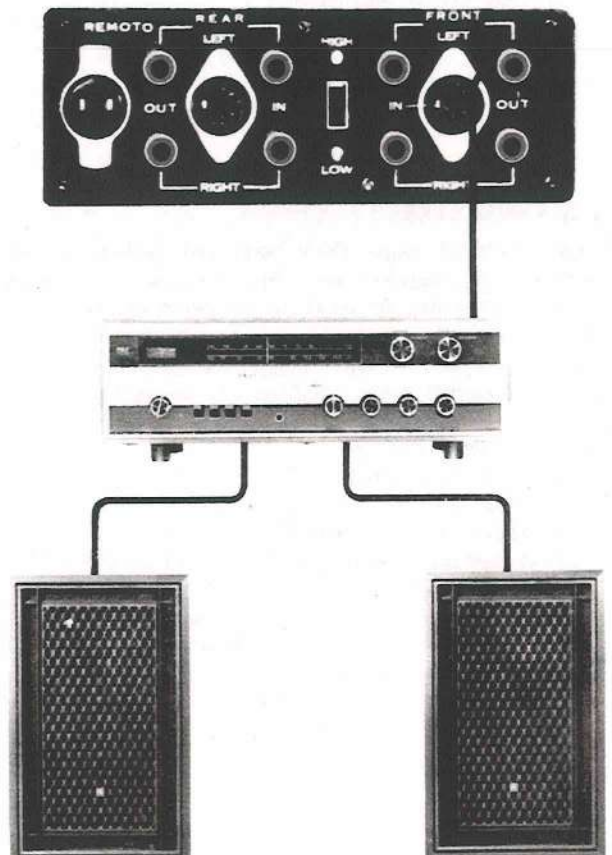

Fig. 28

TRANSFER FROM REEL TO CARTRIDGE TAPE

Connect power cord and load a reel tape.

For 7-1/2 ips reel tape speed, replace pinch wheel and capstan with Transfer Pinch Wheel and Capstan (standard accessory).

For 3-3/4 ips reel tape speed, it is not necessary to replace pinch wheel and capstan.

- A. Turn on Power Switch.
- B. Set Automatic Shut-Off Switch to "OFF" position.
- C. Set Mode Selector to "TRANS".
- D. If 4-channel transfer, set Stereo Selector to "4-CH" position, and if 2-channel transfer, set Stereo Selector to "2-CH" position.
- E. Set Tape Speed Selector to "CART" and set Equalizer to correspond with reel tape speed.
- F. While depressing TRANS/REC Button, set Playback Lever to "REC", and load a cartridge tape to begin recording.

Notes :

1. Adjust Volume Controls while observing VU Meters. Normal recording level is "0" VU.
2. Tone Controls (1800-SS only) have no effect during transfer operation.

Caution : Operate Mode Selector Trans Button only for transfer operation. The use of this button at other times will result in tape erasure.

HEAD CLEANING

To clean cartridge heads, use head cleaning PEN BRUSH (CHC-400 optional accessory) as shown in Fig. 30.

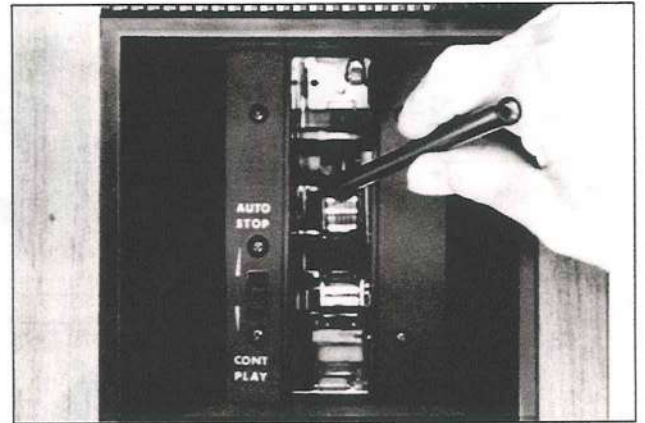
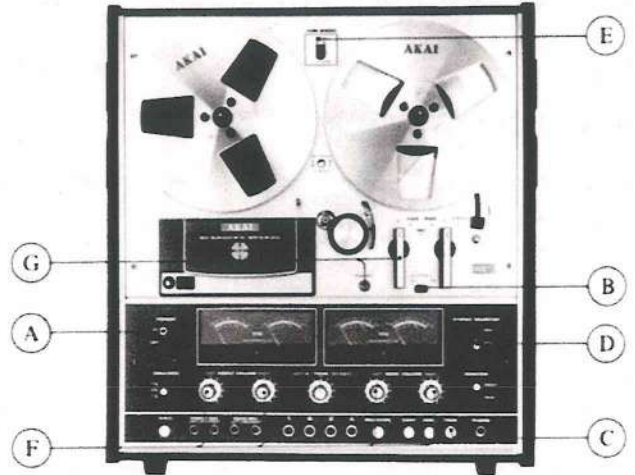

Fig. 30

III. ACCESSORIES

STANDARD ACCESSORIES

Model 1800-SS Tape Recorder

Dynamic Microphone w/Stand	2
7" 4-Channel Demonstration Tape	1
7" Metallic Empty Reel	1
DIN-RCA Connection Cord	1
Cartridge Tape	1
Spare Fuse	2
Operator's Manual	1

Model 1800D-SS Tape Deck

7" 4-Channel Demonstration Tape	1
7" Metallic Empty Reel	1
DIN-RCA Connection Cord	2
Cartridge Tape	1
Spare Fuse	1
Operator's Manual	1

STEREO HEADPHONES



ASE-22



ASE-20



ASE-9S

HEAD DEMAGNETIZER



AH-8

TAPE SPLICER



AS-3

REMOTE CONTROL UNIT



ARC-18

DYNAMIC MICROPHONES



Uni-directional UM-101



Non-directional DM-13

HEAD CLEANING KIT



HC-500

AKAI CARTRIDGE TAPES

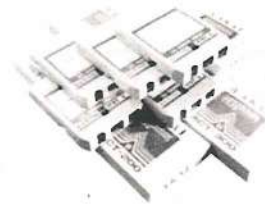

ACT-200 ACT-300

CONNECTION CORDS



D-100



RM-130

Amplifiers & Speaker Systems.

4-WAY 4-SPEAKER SYSTEM



SW-180A

**SOLID STATE FM/AM MULTIPLEX
STEREO TUNER AMPLIFIER**



AA-6600

5-WAY 6-SPEAKER SYSTEM



SW-175

**SOLID STATE FM/AM MULTIPLEX
STEREO TUNER AMPLIFIER**

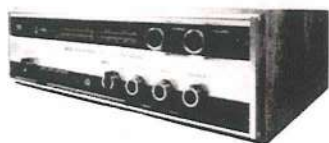

AA-6300

3-WAY 3-SPEAKER SYSTEM



SW-145

SURROUND STEREO PRE-MAIN

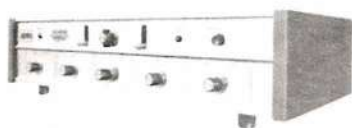

AA-6100

JET STREAM SYSTEM



SW-35

MEMOS

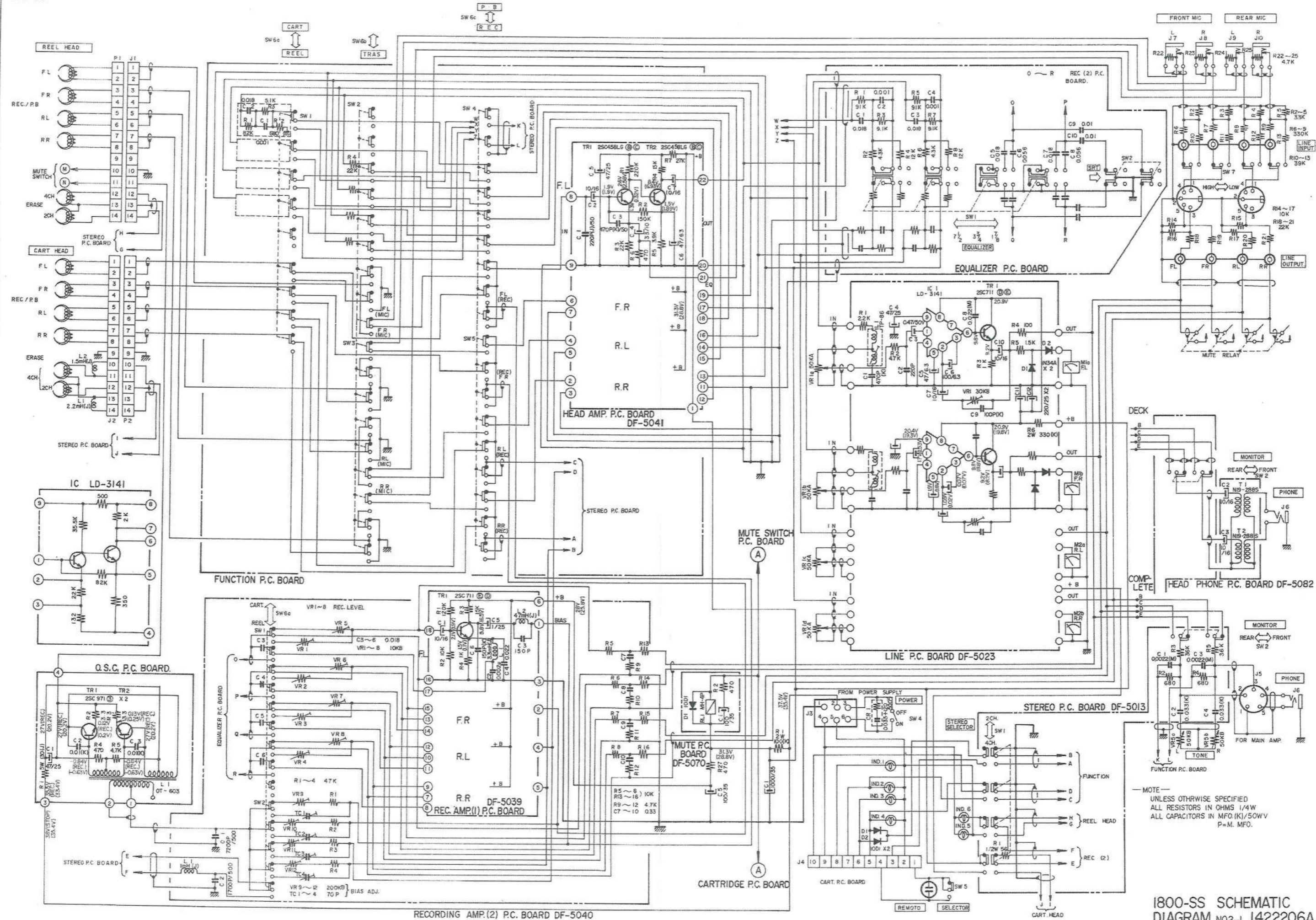

NOTE
UNLESS OTHERWISE SPECIFIED
ALL RESISTORS IN OHMS 1/4W
ALL CAPACITORS IN MFD (K)/50WV
P=M. MFO.

1800-SS SCHEMATIC
DIAGRAM NO2-1 142206A
2C

