

SONY®
SERVICE MANUAL

AV-3420CE

VIDEOCORDER

REVISED 1

SONY CORPORATION

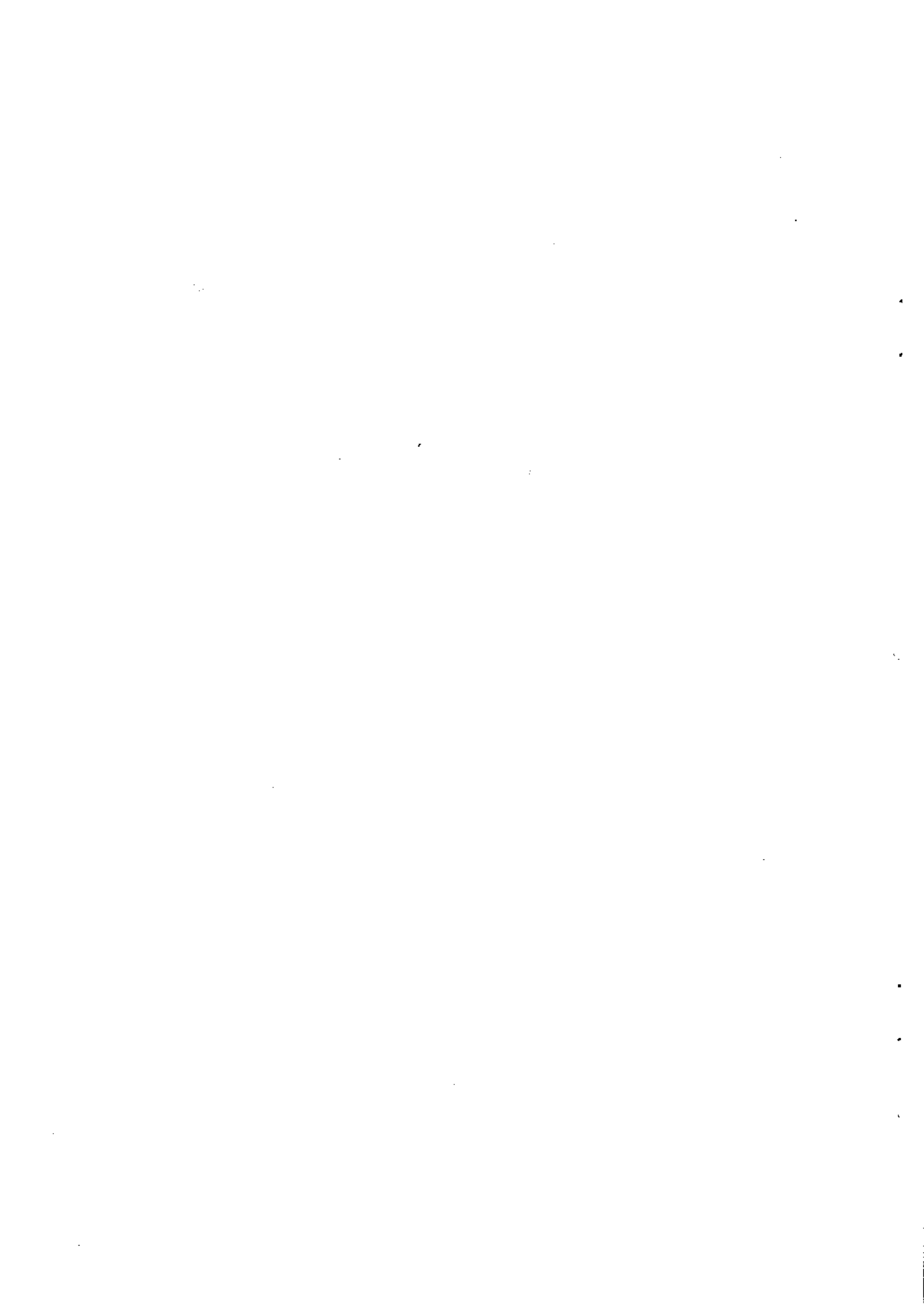

SONY®
SERVICE MANUAL

AV-3420CE
VIDEOCODER

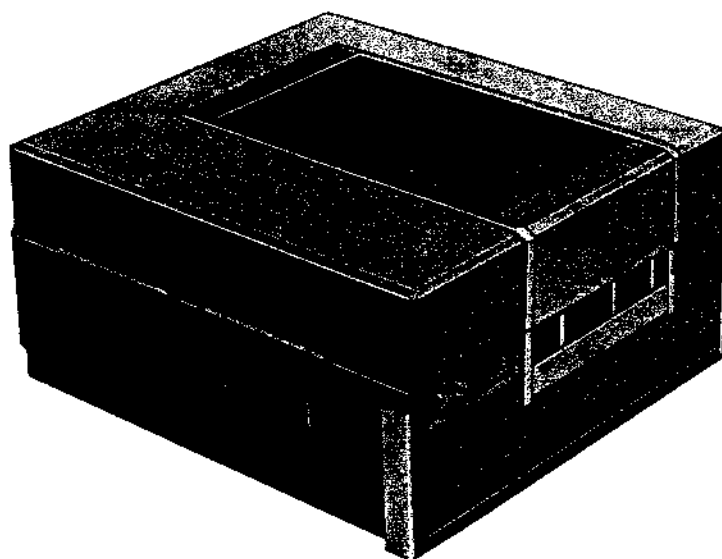

SONY CORPORATION

TABLE OF CONTENTS

<i>Section</i>	<i>Title</i>	<i>Page</i>	<i>Section</i>	<i>Title</i>	<i>Page</i>
1. GENERAL DESCRIPTION					
1-1.	Introduction	1-1	6-6.	Record Bias Setting	6-2
1-2.	Specifications	1-1	6-7.	Bias Trap Adjustment	6-2
1-3.	Location of Parts and Controls	1-2	6-8.	Record Level Adjustment	6-2
1-4.	Operation	1-4			
2. DISASSEMBLY			7. MECHANICAL SYSTEM MAINTENANCE		
2-1.	Cabinet Removal	2-1	7-1.	Introduction	7-1
2-2.	Electrical Service	2-1	7-2.	Cleaning Heads and Slip-rings	7-1
2-3.	Tape Transport Service	2-2	7-3.	Video Head Replacement	7-3
3. POWER SUPPLY ALIGNMENT			7-4.	Audio/Control Head Replacement	7-6
3-1.	Power Supply Adjustment	3-1	7-5.	Stop Brake Adjustment	7-7
3-2.	Battery Meter Calibration	3-1	7-6.	Pinch Roller Pressure Adjustment	7-8
4. SERVO SYSTEM ALIGNMENT			7-7.	Tape Tension Brake Check	7-8
4-1.	Alignment Sequence	4-1	7-8.	Fast Forward Pulley Adjustment	7-9
4-2.	Equipment Required	4-1	7-9.	Take-up Torque Adjustment	7-9
4-3.	Adjustment Procedure	4-1	7-10.	Sub-motor Replacement	7-10
5. VIDEO SYSTEM ALIGNMENT			8. CIRCUIT DESCRIPTION		
5-1.	Equipment Required	5-1	8-1.	Video Circuit	8-1
5-2.	Alignment Sequence	5-1	8-2.	Servo Circuit	8-2
5-3.	Deviation Adjustment	5-1	8-3.	Audio Circuit	8-7
5-4.	Tape Path Check	5-3	8-4.	Power Supply	8-8
5-5.	Modulator Symmetry Adjustment	5-3	8-5.	Camera Remote Control Circuit ...	8-8
5-6.	Carrier Leak Adjustment	5-3	9. TAPE TRANSPORT DESCRIPTION		
5-7.	Monitor Level Adjustment	5-4	9-1.	Tape Path	9-1
5-8.	Record Current Adjustment	5-4	9-2.	Tape Transport in Playback Mode	9-2
5-9.	Playback Preamplifier Frequency Response Adjustment	5-4	9-3.	Instant Stop Mechanism	9-4
6. AUDIO SYSTEM ALIGNMENT			9-4.	Tape Transport in the Record Mode	9-5
6-1.	Alignment Sequence	6-1	9-5.	Audio Dub Mechanism	9-6
6-2.	Equipment Required	6-1	9-6.	Tape Transport in the Fast Forward Mode	9-7
6-3.	Audio Head Azimuth Adjustment	6-1	9-7.	Tape Transport in the Rewind Mode	9-8
6-4.	Playback Level and Frequency Response Adjustment	6-1	10. SCHEMATICS AND EXPLODED VIEWS		10-1
6-5.	Bias Oscillator Check	6-2		Block Diagram	10-1
				Schematics Diagram	10-5
				Exploded Views	10-7

SECTION 1 GENERAL DESCRIPTION

1-1. INTRODUCTION

The Model AV-3420CE is a lightweight, compact, portable Videocorder with a built-in three-way power supply and may be operated from power, a BP-20 battery, or a car battery. The unit provides high-quality video/audio record and playback functions. Recorded material can be played back on the camera viewfinder screen, a video monitor connected with a VMC-1M cable or a conventional TV receiver, using the RF Unit.

Two dc motors are used, one for the head drum drive and the other for capstan servo, since both head drum and capstan servo systems are employed.

The recorded pattern on the magnetic tape conforms to SONY AV-CE series standards so that tape interchangeability between all SONY AV-CE series video tape recorders should be maintained.

1-2. SPECIFICATIONS

Video recording system: Rotary 2-head helical scan system, full field, composite video signal based on CCIR TV standards (supplied from the AVC-3420CE Video Camera or a monitor/receiver).

Track pattern: SONY AV-CE series track.

Tape interchangeability: Interchangeable with all other tapes with SONY AV-CE series standard track pattern.

Recording time: 30 minutes continuously with a V-30H tape.

Tape speed: 163.22 mm \pm 0.2%

Video input: 0.5 ~ 2.0 V(p-p), sync negative, 75 ohms, unbalanced.

Video output: 1.0 V(p-p), sync negative, 75 ohms.

Resolution: More than 300 lines

S/N ratio: More than 40 dB

DC level supplied to viewfinder video input: DC 6 V \pm 0.5 V

Audio input (microphone jack): -65 dB, 3,600 ohms, AGC (0 dB = 0.775 V), unbalanced

Audio output (earphone jack): -4 dB, 1 k ohms

Audio overall characteristics: 100 Hz ~ 10 kHz, S/N ratio 40 dB

Maximum record/playback time: Continuously with AC-3420CE power supply or 30 minutes with BP-20

Charging time: 6 hours to charge BP-20

Power requirements: DC, 12 V \pm 1.2 V with BP-20 12.6 W AC, 110, 127, 220 or 240 V \pm 10% with AC-3420CE

Dimensions: 280 mm(W) x 157 mm(H) x 295 mm(D)

Weight: 8.5 kg.

Accessories supplied: AC power adaptor AC-3420CE
Battery pack, BP-20
Empty reel, RH-5E
Earphone, CE-3
Monitor connecting cable, VMC-1M
Polishing cloth
Splicing tape
Cleaning fluid
Shoulder bag

1-3. LOCATION OF PARTS AND CONTROLS

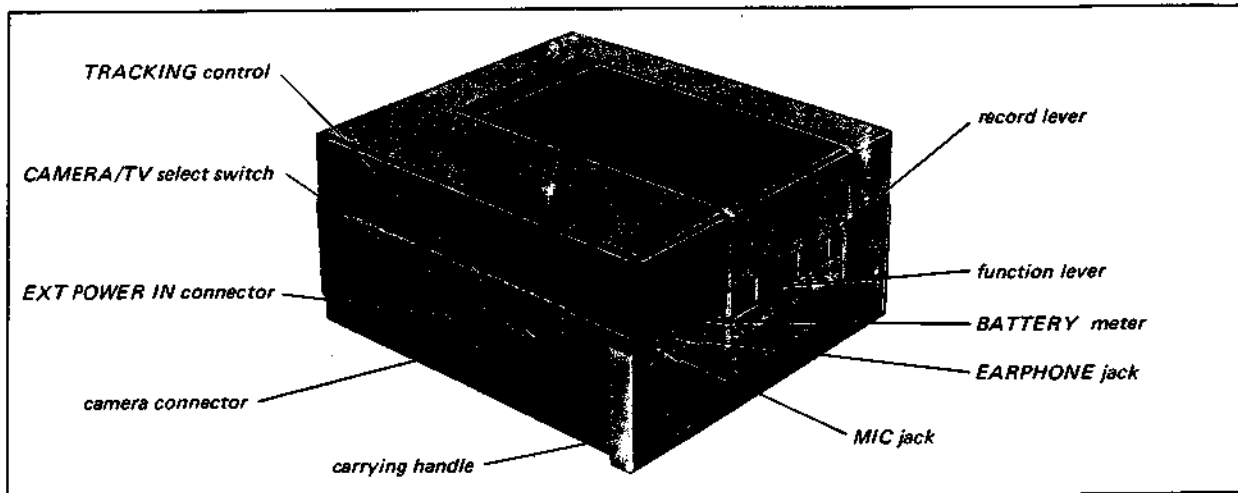

Fig. 1-1

TRACKING control:

Video head tracking is controlled by shifting the control track pulse electronically in the playback mode in order to obtain tape interchangeability.

CAMERA/TV select switch:

Set to the CAMERA position when using the AVC-3420CE camera. A monitor may be

connected with a VMC-1M monitor connecting cable and the selector set to TV.

Camera connector: An AVC-3420CE camera or CVM series monitor can be connected (with a VMC-1M cable). Fig. 1-4 shows the camera connections, Fig. 1-5 TV connections.

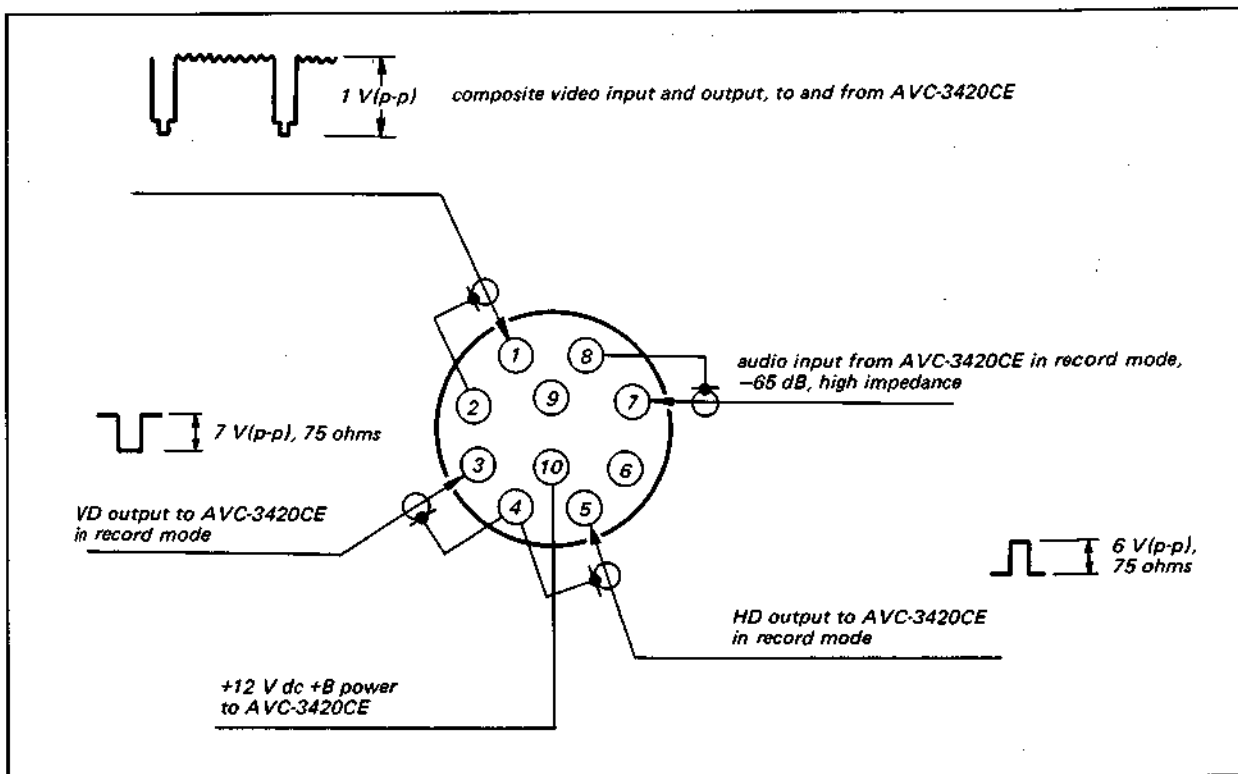

Fig. 1-2 Camera connections with videocorder

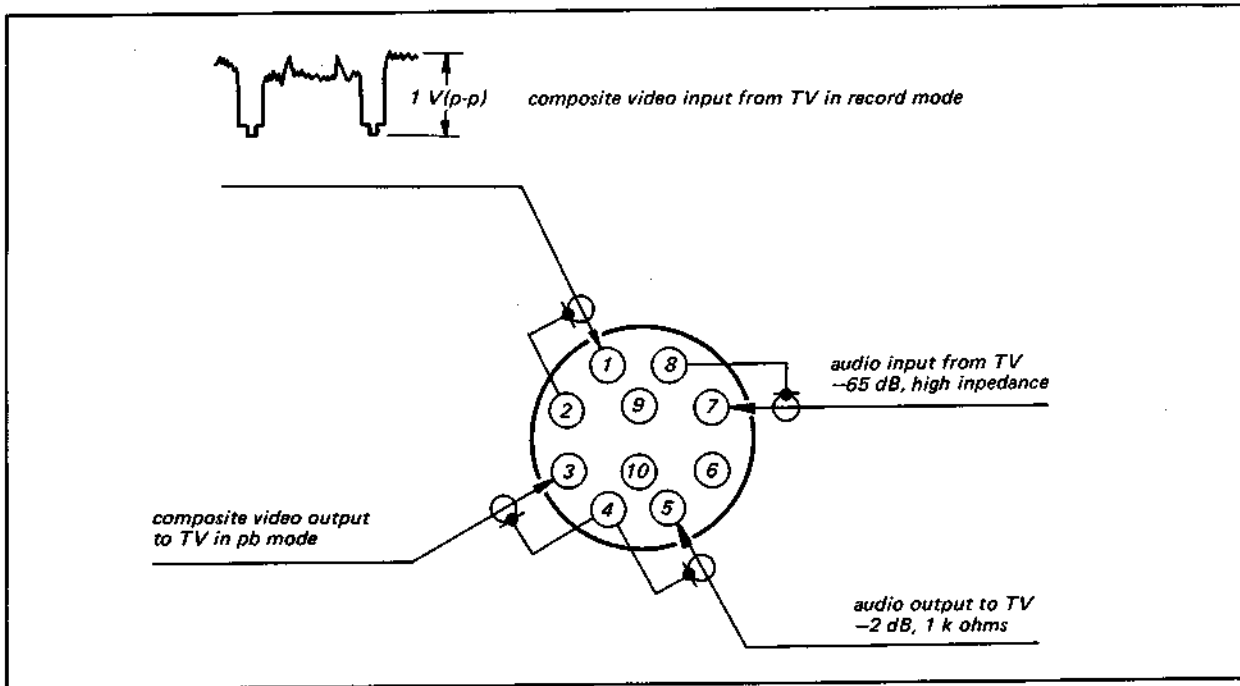

Fig. 1-3 TV connections with Videocorder

- RF out jack:** Output connector for the RF modulator unit (optional). The video output is converted to a VHF signal by the RF modulator and is fed to the TV antenna terminals.
- EXT. POWER IN connector:** Accepts external power from the AC-3420CE ac power supply.
- MIC jack:** Accepts an external microphone, -65 dB, 3,600 ohms

- EARPHONE jack:** Accepts an earphone for monitoring playback audio output. -4 dB, 1 k ohms.
- BATTERY meter:** Indicates battery terminal voltage in record and playback modes. The pointer reads between white and red areas when the voltage drops to 11V dc.
- RECORD lever:** The video and servo systems are put into the record mode by actuating switches on the respective boards.
- Function lever:** Select the desired transport operation by setting the mechanical links, idlers, belts and pullies.
- Time counter:** Indicates the elapsed time in minutes. Drive for this four-digit counter is taken from the capstan sub-roller.
- Video head:** SONY video head type H01-02 commonly used in SONY AV-3620CE, AV-3670CE Videocorders.
- SOUND DUB knob:** Puts the audio channel into the record mode while the video channel is in the playback mode.

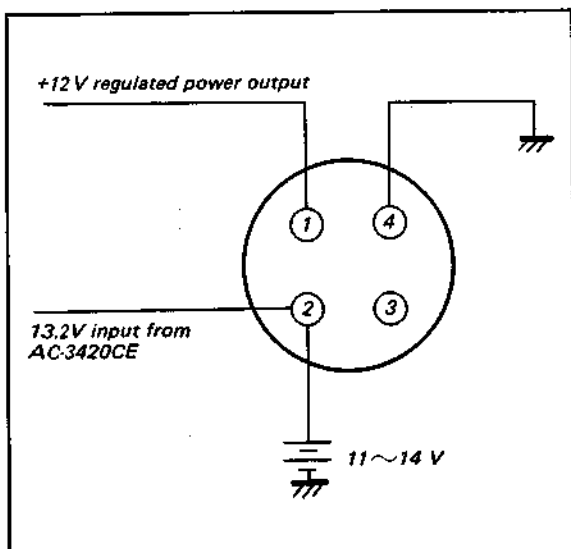

Fig. 1-4. AC-3420CE connection

STILL knob: Releases the pinch roller from the capstan temporarily to produce a still-frame picture.

Automatic shut-off switch: Power to the VTR is shut off by a microswitch when tape slackens or runs out.

1-4. OPERATION

1-4-1. Power Source

The AV-3420CE Videocorder operates from a built-in rechargeable battery pack. Ac power is supplied by connecting the AC-3420CE ac Power Adaptor which also permits battery charging. Operation from a 12V car battery is also possible using the DCC-2400 Car Battery Cord (optional).

Battery installation

1. Open the battery compartment cover by turning the screw with a coin.
2. Plug the cord from the battery pack into the jack inside the battery compartment.

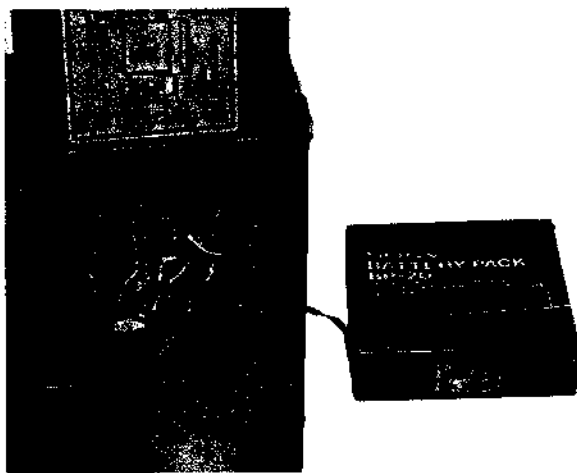

Fig. 1-5

3. Install the battery pack and close the compartment cover.

Battery life

A fully-charged battery allows approximately 30 minutes of continuous operation of both Video corder and camera. The pointer of the BATTERY meter shows battery condition when the Videocorder is turned on; a white-zone reading shows that the

battery is in good condition, a red-zone reading shows that the battery is discharged. The Videocorder and camera will not perform properly with a weak battery. If the pointer of the BATTERY meter is in the red zone, recharge the battery at once.

Note: The battery is fully charged when it leaves the factory. However, an idle battery will discharge slowly over a long period of time. Therefore, the battery may not yield a full 30 minute operation when it is first put into service. Full capacity will be restored, however, after the first recharge.

Car battery operation

Insert the cigarette-lighter plug of the car battery cord into the cigarette lighter socket in the car and male plug of the other end into the EXT POWER IN connector on the Videocorder. For further details, refer to the instruction manual included with the DCC-2400 Car Battery Cord.

Ac power operation

1. Plug the power cord of the AC-3420CE ac Power Adaptor into an ac outlet.
2. Insert the round plug of the adaptor into the EXT POWER IN connector on the Videocorder.
3. Press the adaptor POWER switch on. The red Pilot Lamp will light and power will be supplied to the Videocorder.

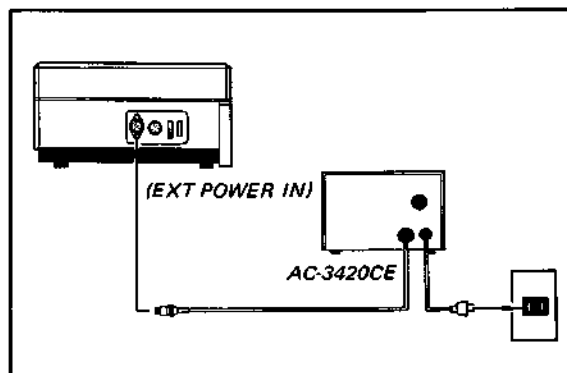

Fig. 1-6 AC-3420CE connection

1-4-2. Tape Threading

1. Place an empty reel on the Take-Up Reel Spindle and a full reel on the Supply Reel Spindle.

- Unwind about 70 cm of tape and thread it onto the Take-Up Reel according to the direction of the arrow.

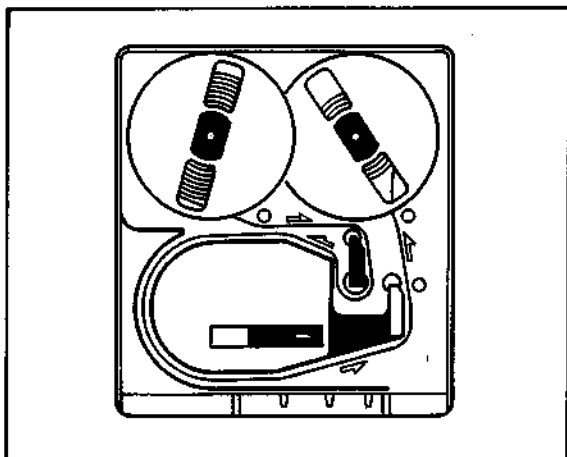

Fig. 1-7 Tape threading

- Turn the Take-Up Reel by hand to take up any excess slack in the tape path.

1-4-3. Recording with The Video Camera

- Insert the camera cable of the AVC-3420CE into the Camera Connector of the Videocorder: Plug the 10-pin connector into the Camera Connector on the Videocorder by matching the slot in the plug with the guide pin on the receptacle. Turn the locking collar of the cable clockwise until the cable locks firmly into place.
- Set the CAMERA/TV switch to CAMERA.
- Press the Time Counter Reset Button to set the Time Counter to (000). This counter indicates recording time as well as the amount of the tape used. When you read the counter as a time indicator, read it as follows.

13.5	13.5 minutes or 13 minutes
30	30 seconds
0.9	0.9 minutes or 54 seconds
- First, set the Record Lever to the REC position and then the Function Lever to FWD (before releasing the Record Lever). The Record Lever will lock into place and the Videocorder and camera will remain in the Standby mode.
- Adjust the camera to obtain a satisfactory picture as displayed on the viewfinder.

- To start the recording, press the Grip Switch on the hand grip of the camera, or push the Start Button at the right side of the lens mount.
- To monitor the sound, plug the earphone into the EARPHONE jack on the control panel of the Videocorder. Sound picked up by the microphone built into the camera will be recorded simultaneously. Picture and sound levels are automatically adjusted by the SONY-MATIC recording system in the Videocorder and camera.
- To stop recording, press the Grip Switch on the hand grip or the Start Button again. At the end of the recording, set the Function Lever to STOP.

1-4-4. Recording TV Programs

- Connect the 8-pin connector on the SONY video monitor to the 10-pin Camera Connector on the Videocorder using a VMC-1M connecting cable (supplied).

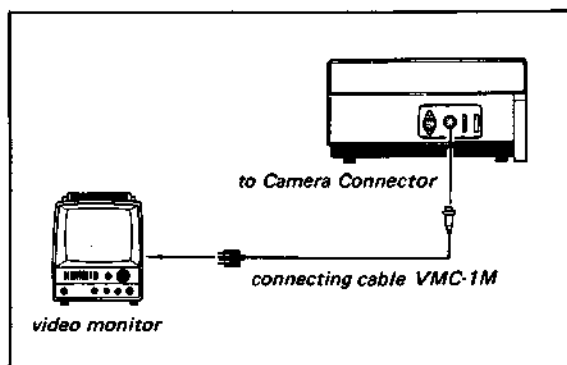

Fig. 1-8 Monitor connection

- Set the CAMERA/TV switch to TV.
- Set the Time Counter to (000).
- Turn on the monitor and set the TV/VTR switch on the monitor to VTR.
- Hold the Record Lever in the REC position to place the Videocorder in the E-to-E mode. Adjust the controls on the monitor for the best possible picture.
- Holding the Record Lever, set the Function Lever to FWD. Video and audio recording will start. No adjustment of video and audio signal levels is required.

- To stop recording, set the Function Lever to STOP.

Note: Television programs may be copyrighted. Recording of such material, particularly if for commercial purposes, may be contrary to provisions of the United States copyright laws.

1-4-5. Tape Playback

The playback picture can be viewed on the camera viewfinder screen, a monitor screen, or a conventional TV screen with appropriate accessories.

Note: When playing back a tape which has been interrupted during the Record mode, picture distortion may be observed during the transitions.

Playback on the viewfinder screen

Connect the AVC-3420CE Camera to the Camera Connector of the Videocorder and set the Function Lever to FWD.

Playback on the monitor screen

Connect the monitor to the Camera Connector using the VMC-1M connecting cable and set the Function Lever to FWD.

Playback on a conventional TV screen

The output signal of the Videocorder is converted to an ordinary TV (rf) signal by an optional accessory RF Unit, which can be installed inside the battery compartment. The rf signal is fed to the antenna terminals of the TV set through the Antenna Selector ANS-1, supplied with the RF Unit.

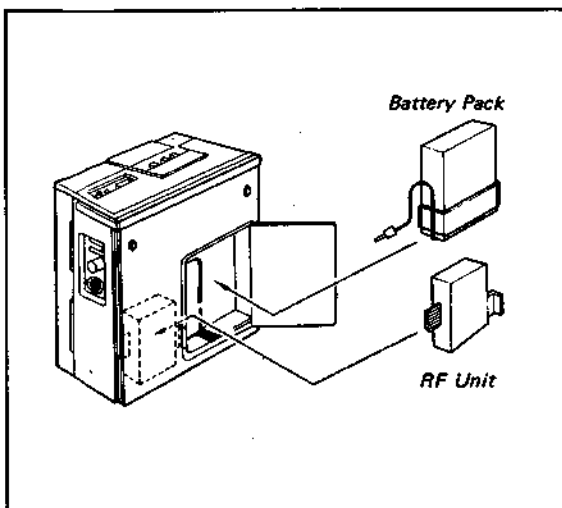

Fig. 1-9 Battery and RF pack installation

- Take the battery pack out of the battery compartment and insert the RF Unit.
- Replace the battery pack as before.
- Connect the feed wire of the Antenna Selector to the external antenna terminals (300 ohms) of the TV set.
- Set the ANT/VTR switch on the Antenna Selector to VTR. When the Videocorder is not in use, the TV set may be operated as a normal television receiver by setting the ANT/VTR switch to ANT position and connecting the 300-ohm external antenna to the antenna terminals of the Antenna Selector.
- Plug the cord from the Antenna Selector into the RF OUT jack on the Videocorder.
- Set the TV channel selector to the channel to which the RF Unit is set.

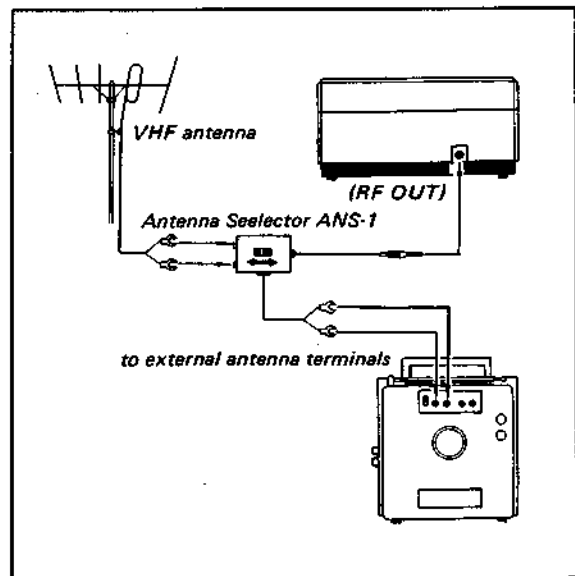

Fig. 1-10 Antenna connection

STILL playback

A stop-motion picture is obtained by pulling the STILL knob down in the direction of the arrow. To release the STILL mode, return the knob to its normal position.

TRACKING adjustment

When playing back a tape recorded on a different AV-Series Videocorder, adjust the TRACKING control should any noise appear in the picture. For normal playback, set the red mark on the knob to the center position.

1-4-6. Sound Dubbing

New sound (from a microphone, tape recorder, phonograph, radio, etc.) can be recorded on a prerecorded tape.

1. Connect the sound source to the MIC jack on the Videocorder.
2. Play back the prerecorded tape and watch the playback picture on the viewfinder, monitor, or television receiver.

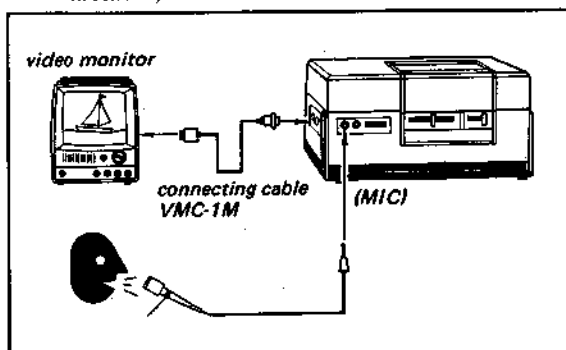

Fig. 1-11 Sound dubbing

3. When the desired position for dubbing sound is reached, set the Function Lever to STOP.
4. Pull the SOUND DUB knob in the direction of the arrow and then set the Function Lever to FWD.
5. When dubbing is complete, set the Function Lever to STOP.

1-4-7. Tape Erasing

Erasure of prerecorded tapes is accomplished automatically as the tape first passes the erase head then moves on to the video (recording) heads.

Should you desire to erase tape without recording, run the tape in the record mode with no signal source connected.

1-4-8. Battery Charging

The built-in battery pack can be recharged with or without removing it from the Videocorder.

Charging the battery pack inside the Videocorder

1. Connect the AC-3420CE ac Power Adaptor to the Videocorder and to an ac outlet.
2. Press the POWER switch to turn on the adaptor. The red Pilot Lamp will light.
3. Set the Function Lever of the Videocorder to STOP. Charging will then be started and the Charging Meter on the adaptor will indicate charging condition. While charging, the pointer remains in the black zone (CHARGING). When the battery is completely charged, the pointer stops at the end of the red zone (FULL). About 6 hours is required for full charging.

Charging the battery pack outside the Videocorder

1. Take the battery pack out of the Videocorder.
2. Connect the AC-3400 adaptor to an ac outlet.
3. Insert the plug from the battery pack into the Charging Jack (BATT) on the adaptor.
4. Press the POWER switch to turn on the adaptor. Battery charging will start and the Charging Meter will indicate charging condition.

Note: Two battery packs can be recharged simultaneously, one inside and one outside the Videocorder.

When the Charging Meter stops at the FULL position, the two battery packs are fully charged. In this case, about 10 hours is required for full charging.

To check whether or not the battery is fully charged, turn off the power, then turn it on again. The pointer should swing down a little and in a few seconds swing back to the FULL position. This shows a completely charged battery.

SECTION 2 DISASSEMBLY

2-1. CABINET REMOVAL

The cabinet may be removed by taking out the eight screws indicated in Fig. 2-1 and Fig. 2-2. Keep the cabinet lid on when removing these screws.

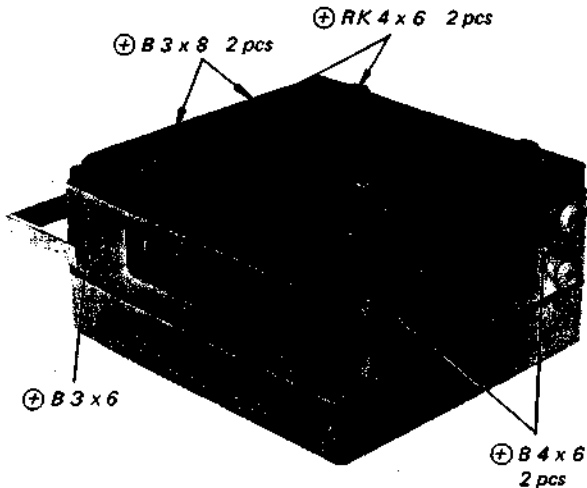

Fig. 2-1.

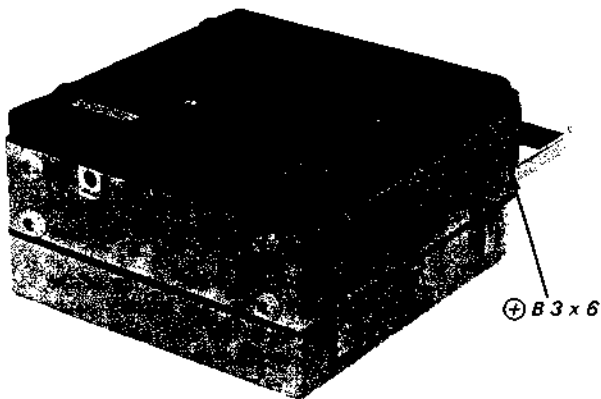

Fig. 2-2.

2-2. ELECTRICAL SERVICE

Video, audio, and servo circuits are exposed for service by removing the bottom reinforcement beam, RF unit housing, and insulation sheet.

1. Remove the two Phillips-head screws that secure the bottom reinforcement beam and remove the beam. See Fig. 2-3 (A).

2. Remove the four Phillips-head screws as indicated in Fig. 2-3 (B) and remove the RF unit housing and insulation sheet.

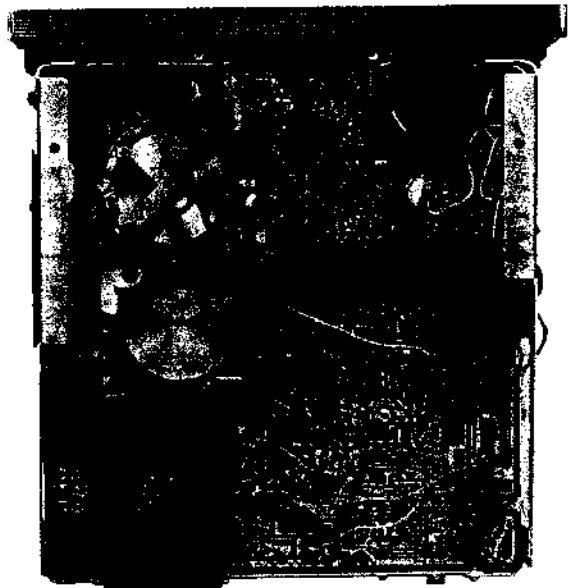

Fig. 2-3 (A)

The video, audio, and servo boards are mounted on hinges. Remove four screws at the corners to release the board so that both sides are accessible. See Fig. 2-4.

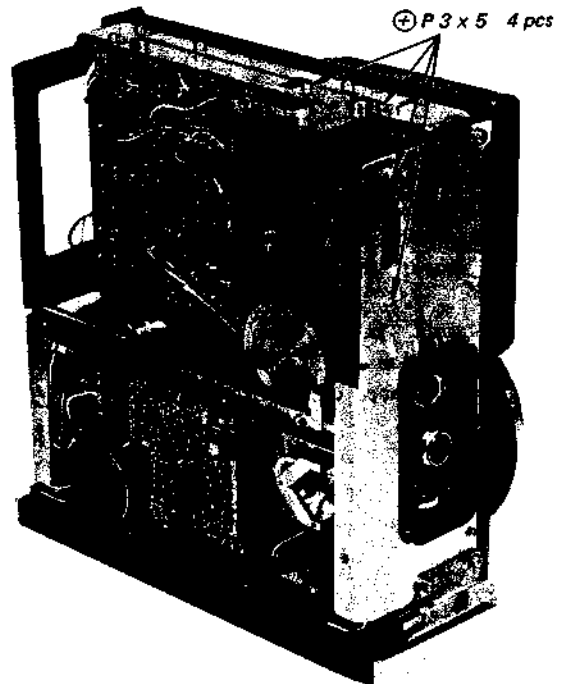

Fig. 2-3 (B)

2-3. TAPE TRANSPORT SERVICE

The tape transport mechanism is exposed for service by removing the reel panel. Loosen the screws indicated in Fig. 2-5, and remove the reel panel.

The front control panel with carrying handle can be removed by taking off the four Phillips-head screws at the ends of the control panel.

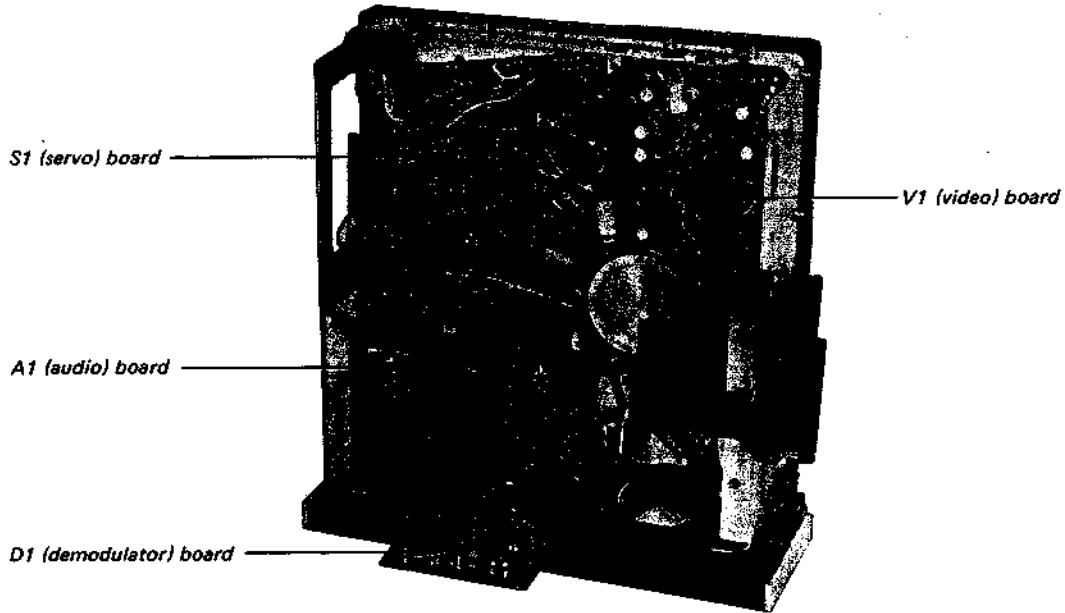

Fig. 2-4

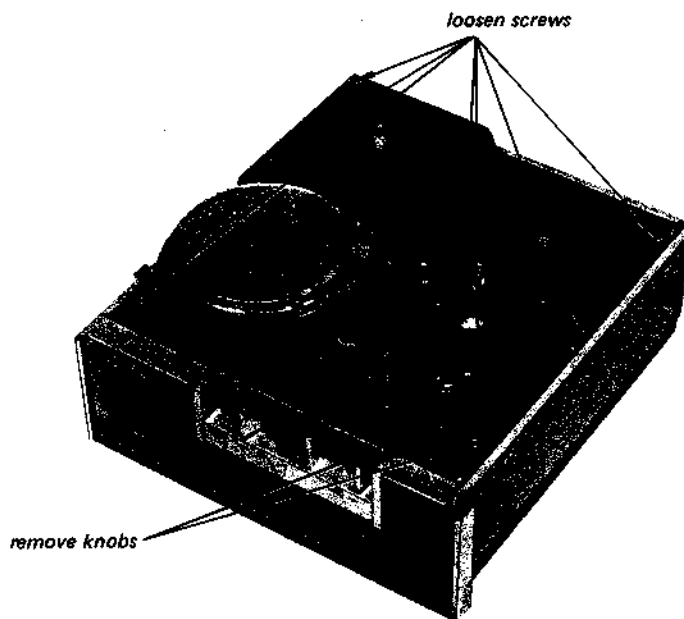

Fig. 2-5

SECTION 3 POWER SUPPLY ALIGNMENT

3-1. POWER SUPPLY ADJUSTMENT

Test Point: Q902 emitter
Adjust for: +9V dc
Adjustment: R907

Procedure:

1. Connect VOM to Q902 collector.
2. Check that the input voltage is 12V ~ 13.5 V dc.
3. Reconnect VOM to Q902 emitter.
4. Adjust R907 for 9V dc.

3-2. BATTERY METER CALIBRATION

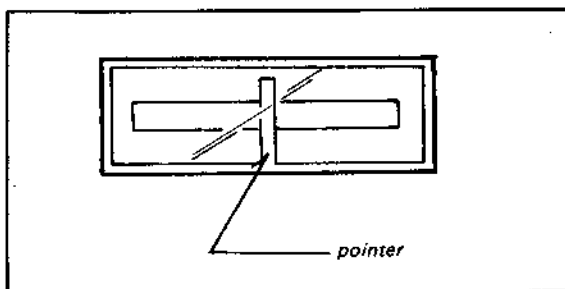

Fig. 3-1

Test Point: Q902 collector.
Adjust for: Meter pointer reads between the red and white region when power supply is 11V dc
Adjustment: R912

Procedure:

1. Disassembly AC-3420CE and connect it to VTR.
2. Connect VOM to Q902 collector of VTR.
3. Adjust AC-3420CE output adjustment (R17) for an 11V dc reading.
4. Adjust R912 so that the battery meter reads between the red and white regions of the scale. Readjust AC-3420CE (R17) for original setting of 14.6V output.

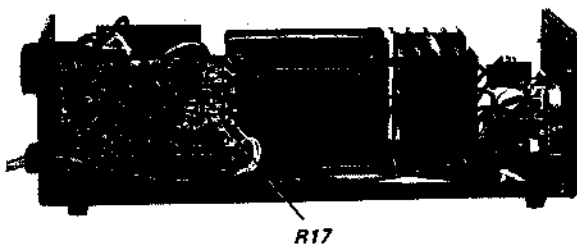

Fig. 3-2 AC-3420CE

SECTION 4 SERVO SYSTEM ALIGNMENT

4-1. ALIGNMENT SEQUENCE

The servo system alignment sequence is shown in Chart 4-1.

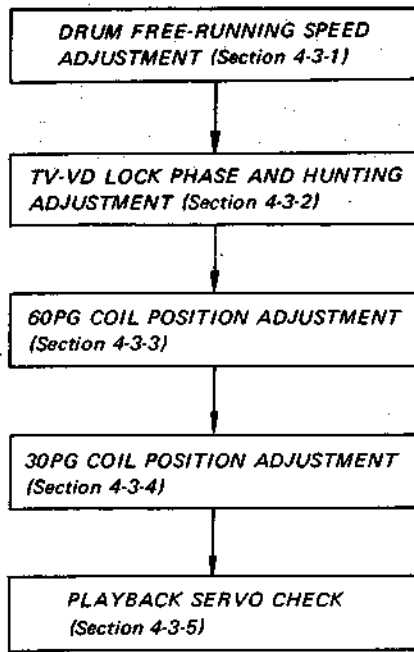

Chart 4-1 Servo system alignment

4-2. EQUIPMENT REQUIRED

Monitor: SONY CV monitor
 Frequency counter:
 Oscilloscope:
 TV camera: SONY model AVC-3420CE camera
 Monitor connection cable: SONY model VMC-1M cable
 Power supply: AC-3420CE or BP-20

4-3. ADJUSTMENT PROCEDURE

In TV record mode, the servo should lock to the TV vertical sync signal. The free-running speed of the head drum is 12,650 Hz.

4-3-1. Drum Free-Running Speed Adjustment

Test Point: TP-601
 Adjust for: 12,650 Hz \pm 10 Hz
 Adjustment: R621
 Signal source: None

Equipment Required:

Frequency Counter

Procedure:

1. Disconnect cable from TV-CAMERA connector at the monitor.
2. Set TV-CAMERA Select switch to TV.
3. Thread tape on VTR.
4. Check for +9V +B voltage.
5. Connect frequency counter to TP-601 of the servo board.
6. Set up the record mode and check the frequency counter reading.
7. Adjust R621 so that the frequency counter reading is 12,650 Hz \pm 10 Hz.

4-3-2. TV-VD Lock Phase Adjustment and Hunting Adj.

Test Point: TP-704 Servo board
 Adjust for: Correct servo lock phase
 Adjustment: R731 (lock phase), R732 (hunting)
 Signal source: Telecast signal

Equipment Required:

1. Oscilloscope
2. Monitor

Procedure:

1. Connect the monitor with a VMC-1M cable.
2. Set the TV-CAMERA Select switch to TV.
3. Connect scope to TP-704; set up the 2V/cm, 5 ms/cm range.

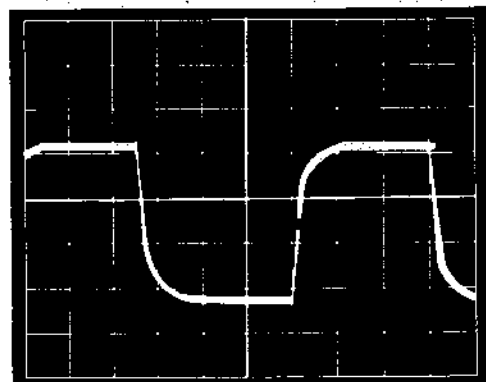

Fig. 4-1.

4. Thread the tape and set up the record mode.
5. Adjust R731 so that the PG pulse appears midway between the positive and negative peaks. See Fig. 4-1.
6. Stop the VTR. Pull the REC Lever and measure the time required to stop the PG pulse on the rectangular pulse. If it takes more than 6 seconds, adjust R732.

4-3-3. 50 PG Coil Position Adjustment

Test Point: TP-708 (CH-1), TP-301 (CH-2)
 Adjust for: 50 PG pulse at the center of channel overlap.
 Adjustment: 50 PG Coil
 Signal source: None

Equipment Required:

1. Video Alignment Tape or Prerecorded Tape
2. Oscilloscope

Procedure:

1. Thread a SONY video alignment tape or any prerecorded tape that is recorded by a correctly-aligned VTR.
2. Connect the scope CH-1 probe to TP-708 and the CH-2 probe to TP-301. TP-708 is on the Servo board and TP-301 is on the Demodulator board.

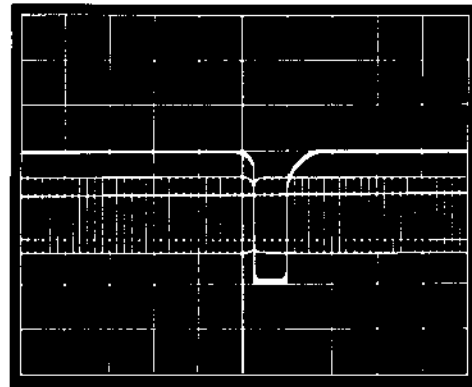

Fig. 4-3.

3. Set the scope horizontal time base to 5 ms/cm. Sync on CH-1 only.
4. Set up the playback mode.
5. Adjust scope controls to observe both signals. Then set the scope MODE SWITCH to the CHOP position. Pull out the 5X magnifier and adjust the HORIZONTAL POSITION to observe the vertical blanking interval.
6. Bend the tip of the 50 PG coil with pliers and adjust the coil position so that maximum rf output is obtained in the overlap period. See Fig. 4-2 and Fig. 4-3.

4-3-4. 30PG Coil Position Adjustment

Test Point: TP-304 (CH-1), TP-708 (CH-2)
 Adjust for: 50 PG leads VD by $8 H \pm 1 H$
 Adjustment: 25 PG coil
 Signal source: TV telecast signal

Equipment Required:

1. Oscilloscope
2. Monitor TV

Procedure:

1. Connect scope CH-1 probe to TP-304 on the "D1" board and CH-2 probe to TP-708 on "S1" board. Set scope time base to 5 ms/cm. Sync the scope externally from TP-703.
2. Connect monitor.
3. Set TV-CAMERA Select switch to TV.
4. Set up record mode.
5. Set the scope MODE SELECT switch to the

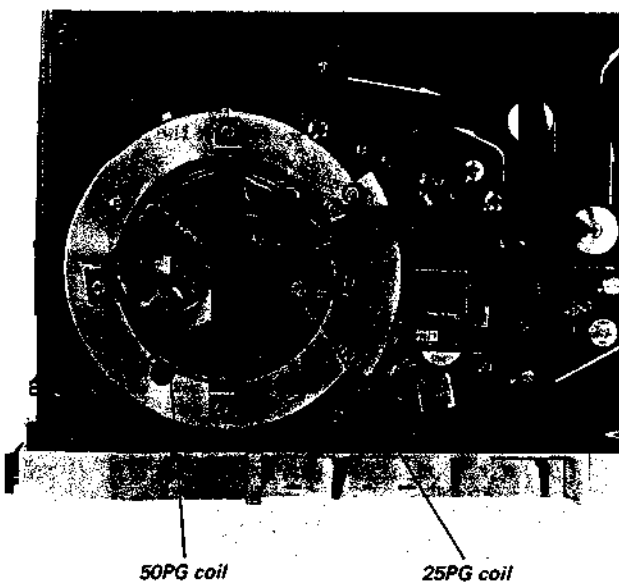

Fig. 4-2.

CHOP position. Pull out the 5X magnifier and adjust HORIZONTAL POSITION to observe the vertical blanking interval.

6. Adjust the 25 PG coil so that the 50 PG pulse leads the VD pulse by $8 H \pm 1 H$. See Fig. 4-4.

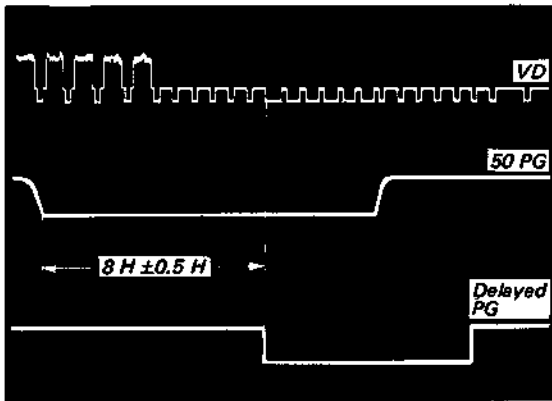

Fig. 4-4.

4-3-5. Playback Servo Check

Test Point:	TP-706
Check for:	Servo locks in center of pull-in range.
Adjustment:	None
Signal source:	None

Equipment Required:

1. Video Alignment tape or prerecorded tape
2. Oscilloscope

Procedure:

1. Connect scope to TP-706. Set up the 2 V/cm, 2 ms/cm ranges.
2. Thread the alignment tape.
3. Set up the playback mode.
4. Check to see that the PG pulse locks in the center of the trailing edge of the rectangular pulse. If not, perform Sec. 4-3. TV record mode speed adjustment. Check also that Q719, Q720 emitter dc potential is between 3.5 V ~ 4.5 V dc.

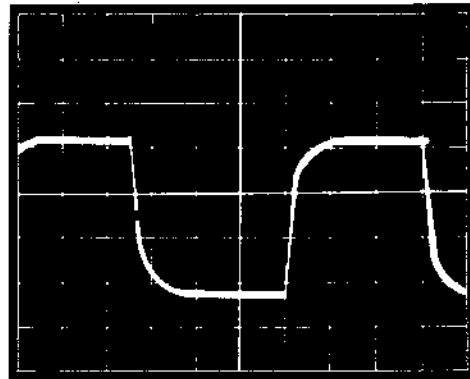

Fig. 4-5.

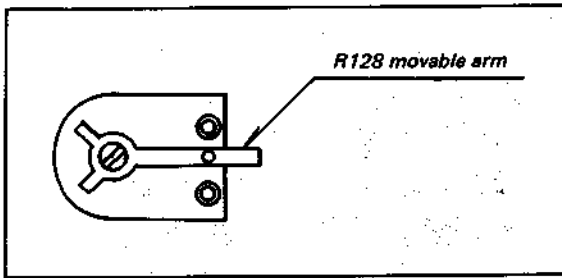

Fig. 5-1

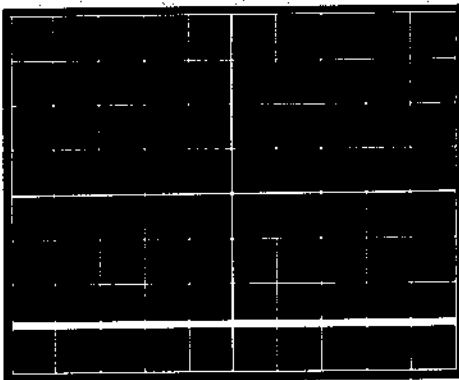

Fig. 5-2

- d. Connect a monitor set up to receive an off-the-air telecast signal.
- e. Check to see that the sync tip of the composite signal sinks below the second division (See Fig. 5-2) by approx. 0.5 V. Measure the exact voltage by which the sync tip sinks below the clamp reference level set in Step 7-c (Fig. 5-2). See Fig. 5-3.

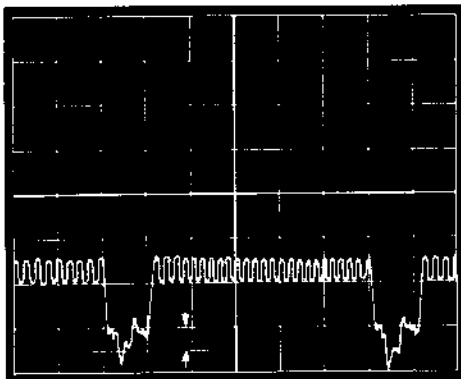

Fig. 5-3 Sync tip level shift

- f. Disconnect the monitor. Keep the VTR in the record mode.
- g. Adjust scope STABILITY to observe a horizontal trace on the same position as seen on Fig. 5-2.

- h. Adjust R128 so that the horizontal trace on the scope moves up by the voltage measured in Step 7-e (Fig. 5-3). See Fig. 5-4.

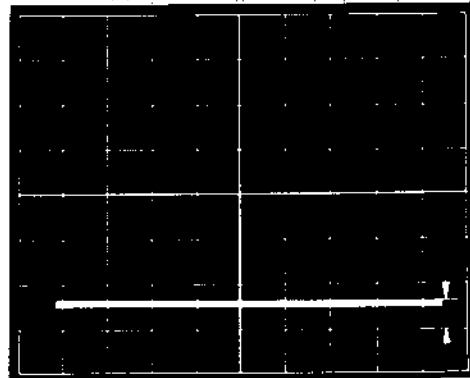

Fig. 5-4 Clamp level

8. Connect scope to TP-104. Set time base to $0.5 \mu\text{s}/\text{cm}$, and check that approx. 22 rectangular pulses per 10 divisions is seen on the scope. Sync tip clamp level is now set to 3.8 MHz.

Note: No-signal frequency is about 4.4 MHz (22 cycles) as a result of these adjustments, but sync tip frequency will be set correctly to 3.8 MHz.

9. Connect scope to TP-304. Set up 5 ms/cm range.
10. Connect a monitor.
11. Play back the video alignment tape.
12. Adjust R343 (video output level) for 1.0V(p-p). Output level is now set to 1.0V(p-p).
13. Thread a blank tape instead of the alignment tape.
14. Record a telecast signal for approx. 15 seconds.
15. Play back the tape and check the video level.
16. If video level is other than 1V(p-p), adjust R106. Turn R106 slightly CW if the video level is less than 1.0V(p-p).
17. Record the telecast signal again and check the video level. Readjust R106 until video level is 1.0V(p-p). This completes maximum deviation adjustments (3.8 MHz to 5.2 MHz).
18. Set up the record mode using a telecast signal.
19. Connect scope to TP-102.

20. Adjust R127 (white clip) so that the extreme white peaks of the waveform are clipped at 40% of "A" volts as shown in Fig. 5-5.



Fig. 5-5 White clip

5-4. TAPE PATH CHECK

CAUTION

Do not try to adjust any components that affect the tape path. Serious deficiencies in performance, such as poor interchangeability, will result if tape path is set improperly. If checks show adjustments are required, return the unit to a SONY FACTORY SERVICE BRANCH.

1. Thread a blank tape.
2. Set up the playback mode.
3. Check the following:
 - a. The tape should run in the center of tape guides, the sub-pinch roller and pinch roller without curling or buckling.
 - b. The core of the Erase Head and Audio/CTL Head must extend an equal amount above and below the tape.
 - c. The tape should ride flush against the Tape Guide Band.
 - d. The tape path in the fast forward and rewind modes should be the same as in the playback mode.
4. Make a recording and play back the tape.
5. Connect the scope to TP-301. Sync the scope externally by TP-708. Check that a reasonably flat rf envelope is observed. If the rf envelope decreases by more than a factor of 2 at every-other vertical field, clean the video heads or replace the video head assembly.

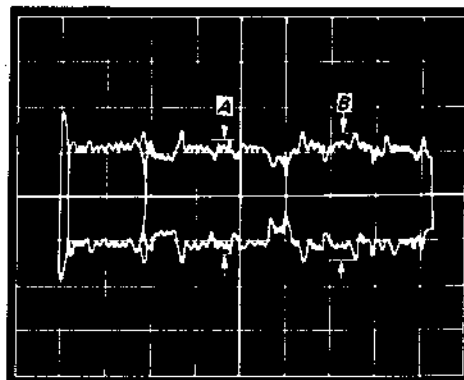

Fig. 5-6

5-5. MODULATOR SYMMETRY ADJUSTMENT

Test Point: TP-103
 Adjust for: Waveform symmetry
 Adjustment: R137 and C119
 Signal source: None

Equipment Required:

1. Dual-trace Oscilloscope

Procedure:

1. Connect both scope probes (CH-1 and CH-2) to TP-103. Set mode selector to ALTER. Invert polarity of channel 1. Set time base to $0.5\mu\text{s}$ and expand sweep to display 2 or 3 square waves.
2. Set up record mode with no input signal.
3. Adjust scope VERTICAL POSITION to overlap the two signals.
4. Adjust for equal pulse width with C119 and for waveshape symmetry with R137.

5-6. CARRIER LEAK ADJUSTMENT

Test Point: Monitor
 Adjust for: Minimum carrier leak
 Adjustment: R315 and R337
 Signal source: Video alignment tape or test pattern

Equipment Required:

1. Monitor
2. Video alignment tape or a video camera

Procedure:

1. Connect monitor
2. Set TV-CAMERA Select switch to TV.
3. Play back the video alignment tape. (If video alignment tape is not available, record a test pattern and make a prerecorded tape to be used as a video alignment tape.)
4. Adjust R315 and R337 for minimum carrier leak.

5-7. MONITOR LEVEL ADJUSTMENT

Test Point: TP-304
Adjust for: 1 V(p-p)
Adjustment: R116
Signal source: Telecast signal

Equipment Required:

1. Monitor

Procedure:

1. Set up record mode using telecast signal.
2. Connect scope across R102 and check that the video signal is approx. 1 V(p-p).
3. Reconnect scope to TP-304.
4. Adjust R116 for 1V(p-p).

5-8. RECORD CURRENT ADJUSTMENT

Test Point: TP-301
Adjust for: Maximum rf output in pb mode
Adjustment: R201
Signal source: Test pattern

Equipment Required:

1. Oscilloscope
2. Video camera AVC-3420CE
3. Earphone

Procedure:

1. Connect video camera, and thread a blank tape.
2. Connect the scope to TP-104.
3. Set up the record mode using a video camera, microphone and test pattern.

4. Adjust R201 to obtain 2.0V(p-p) and call out the voltage reading into the microphone.
5. Adjust R201 clockwise slowly while observing the scope. Set the recording level to each of the following values.

3.0V	3.5V	4.0V	4.5V
5.0V	5.5V	6.0V	

At each increment, call out the voltage reading into the microphone.

6. Rewind the tape.
7. Connect an earphone to the earphone jack.
8. Connect the scope to TP-301.
9. Play back the tape. Note the voltage level (as indicated by the voice recording) at which output is greatest.
10. Reconnect the scope to TP-104.
11. Set up the record mode again.
12. Adjust R201 for the reading that gave maximum output indication during playback.

5-9. PLAYBACK PREAMPLIFIER FREQUENCY RESPONSE ADJUSTMENT

Test Point: TP-301
Adjust for: Correct frequency response
Adjustment: C222, C226, R222, R226, R304, L301
Signal source: Video alignment tape

Equipment Required:

1. Oscilloscope
2. Video alignment tape

Procedure:

1. Connect scope to TP-301. Scope controls should be as follows:
Horizontal timebase: 2ms/cm
Vertical deflection: 0.2 V/cm
2. Sync the scope externally from TP-708.
3. Play back the rf sweep portion of the video alignment tape.
4. Check to see that the sweep signal of Fig. 5-7 is obtained on the scope. If the sweep signal differs from Fig. 5-7, adjust as follows:

- a. Adjust C222 and C226 to obtain maximum amplitude at 5.2 MHz.
- b. Adjust R222 and R226 so that amplitude at 5.2 MHz is same as that of 1 MHz.
- c. Adjust L301 for maximum amplitude at 3.58 MHz.
- d. Adjust R304 so that amplitude of 3.58 MHz is 1.5 times as that of 1 MHz.

C222	R222	C226	R226	L301	R304
CH-A tuning at 5.2 MHz	CH-A level at 5.2 MHz	CH-B tuning at 5.2 MHz	CH-B level at 5.2 MHz	tuning at 3.58MHz	level at 3.58MHz

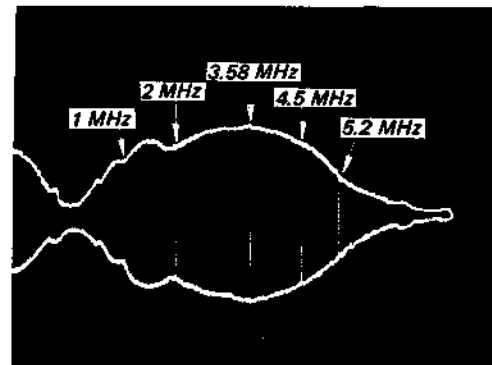

Fig. 5-7 Rf sweep envelope

SECTION 6 AUDIO SYSTEM ALIGNMENT

6-1. ALIGNMENT SEQUENCE

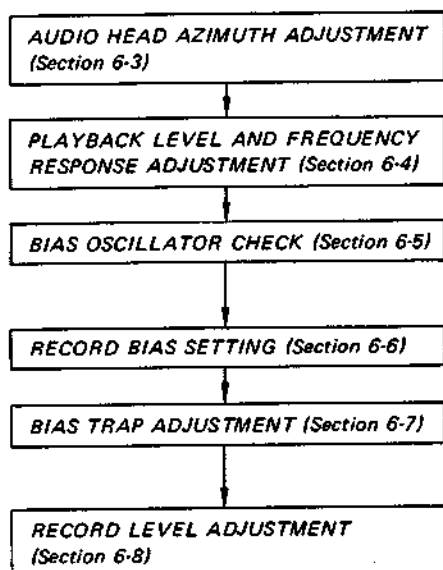

Chart 6-1

Audio system alignment sequence is shown in Chart 6-1. A summary of the alignment procedures is shown in Chart 6-2.

6-2. EQUIPMENT REQUIRED

Audio oscillator:

Audio attenuator:

VTVM:

Shielded cable with earphone plug: SONY model RK-36

SONY alignment Tape, 5" reel.

6-3. AUDIO HEAD AZIMUTH ADJUSTMENT

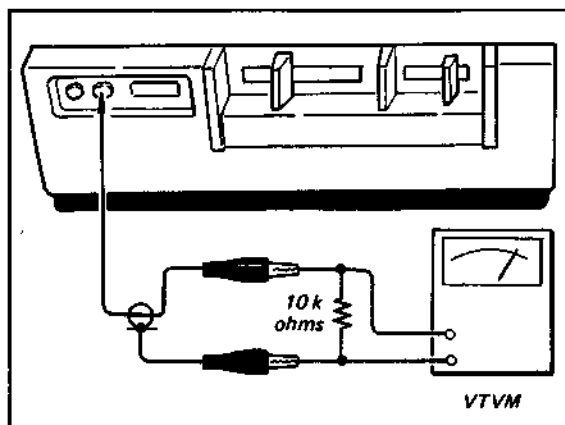

Fig. 6-1 Audio output level check

Test Point: EARPHONE jack (audio output)
 Adjust for: Maximum output reading on VTVM
 Adjustment: Head azimuth adjustment screw
 Signal source: SONY alignment Tape, 5" reel.

Procedure:

1. Play back 7-kHz portion of the SONY audio alignment tape.
2. Connect VTVM as shown in Fig. 6-1.
3. Adjust head azimuth for maximum VTVM reading. See Fig. 6-2.

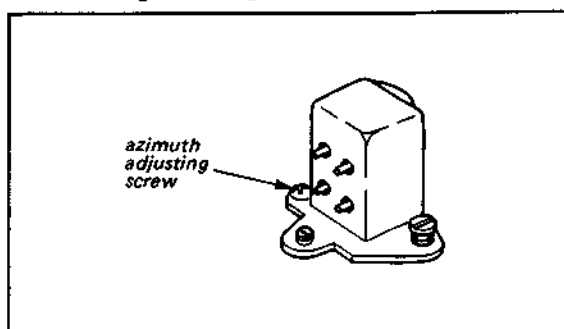

Fig. 6-2 Audio head azimuth adjustment

6-4. PLAYBACK LEVEL AND FREQUENCY RESPONSE ADJUSTMENT

Test Point: EARPHONE jack (audio output)
 Adjust for: 0.61 V (-2 dB) for 1 kHz,
 0.43 V (-5 dB) for 7 kHz
 Adjustment: R814 (1 kHz level),
 R809 (7 kHz level)
 Signal Source: Audio alignment tape

Procedure:

1. Connect VTVM as shown in Fig. 6-1.
2. Play back 1-kHz portion of the audio alignment tape.
3. Adjust R814 for 0.61 V (-2 dB) reading on VTVM.
4. Play back 7-kHz portion of the audio alignment tape.
5. Adjust R809 for 0.43 V (-5 dB) reading on VTVM.

6-5. BIAS OSCILLATOR CHECK

Test Point: TP-801
Check for: 90 to 110V rms
Adjustment: None
Signal source: No signal

Procedure:

1. Set up record mode with no input signal.
2. Connect VTVM to TP-801.
3. Check for 90 to 110V rms reading on VTVM.

6-6. RECORD BIAS SETTING

Test Point: Across head terminals
Adjust for: 36 V rms \pm 0.5 V rms
Adjustment: C829 (normal record mode)
L803 (audio dub mode)
Signal source: No input signal

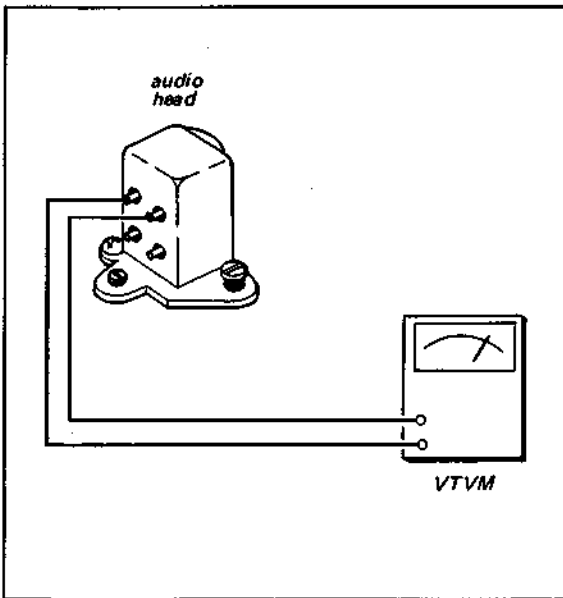

Fig. 6-3 Bias setting

Procedure:

1. Connect VTVM across head terminals.
2. Set up record mode with no signal.
3. Adjust C829 for 36 V rms reading on VTVM.
4. Set up then audio dub mode.
5. Adjust L803 for the same 36 V rms reading on VTVM.

6-7. BIAS TRAP ADJUSTMENT

Test Point: EARPHONE jack (audio output)
Adjust for: Minimum bias leakage
Adjustment: L801
Signal source: No signal

Procedure:

1. Connect VTVM as shown in Fig. 6-1.
2. Set up record mode.
3. Adjust for minimum reading on VTVM.

6-8. RECORD LEVEL ADJUSTMENT

Test Point: EARPHONE jack (audio output)
Adjust for: 0.50V (-4 dB)
Adjustment: R826
Signal source: 1 kHz, -65 dB

Procedure:

1. Connect audio oscillator and attenuator to MIC input jack to provide 1 kHz signal at -65 dB.
2. Connect VTVM as shown in Fig. 6-1.
3. Adjust R826 for 0.50V (-4 dB) reading on VTVM.

SECTION 7 MECHANICAL SYSTEM MAINTENANCE

7-1. INTRODUCTION

Machine compatibility (interchangeability of tapes between machines) depends upon very close mechanical tolerances in the tape path. The tape path is factory-adjusted and should not require realignment under normal circumstances. Do not attempt adjustment of the tape guides, tapered guides and tape guide-band. They should be adjusted with use of adjustment jigs. If mechanical damage requires replacement and/or adjustment of the guides in the tape path, return the machine to a SONY FACTORY SERVICE CENTER for repair.

Visual Check:

Visual check on the unit helps to locate the trouble.

1. Capstan does not rotate.
 - a. Capstan belt drops from pulley.
 - b. Capstan belt slips. Needs replacement.
2. Tape is not wound onto take-up reel or supply reel in respective mode.
 - a. Sub-belt drops from the pulley.
 - b. Sub-belt slips. Needs replacement.
 - c. Take-up belt slips due to accumulation of oil, dust etc. Needs cleaning or replacement. See Sec. 7-8 and 7-9.
3. Tape runs too fast in record and/or playback.
 - a. Insufficient pinch-roller pressure, (See Sec. 7-6) or requires cleaning and replacement.
 - b. Record servo readjustment. (See Sec. 4)
4. Tape slackens when stopping tape.
 - a. Brake system readjustment. (See Sec. 7-5)
5. Too much tape tension.
 - a. Tape back tension readjustment. (See Sec. 7-7)
6. Record mode cannot be set-up.
 - a. RECORD/PLAYBACK Select switch on each circuit board does not function properly. Needs brake link readjustment. (See Sec. 2-3)



Fig. 7-1

7-2. CLEANING HEADS AND SLIP-RINGS

Noise in the picture during playback is usually caused by an accumulation of debris in the video heads. In some cases, half the picture may be noisy (split-screen); in severe cases, video output may be lost.

To clean the heads, stop the machine, remove the tape and move one of the heads to the front. See Fig. 7-2.

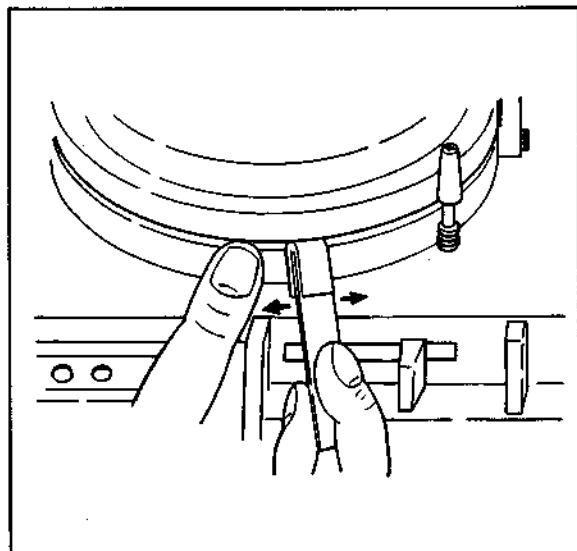

Fig. 7-2 Head cleaning

CAUTION

NEVER TRY TO CLEAN HEADS WITH THE MOTOR RUNNING.

Saturate a cleaning tip (accessory X-36090-19-0) with SONY cleaning fluid (accessory Y-20310-01-0) or methanol (spray cleaner, such as M/S-brand magnetic head cleaner.) Rub the cleaning tip across the head tip from side to side. Avoid vertical motion which might damage the video head.

Clean the erase and audio/control heads with SONY cleaning fluid, if necessary. Move the cleaning tip vertically across that part of the head surface that normally contacts the tape.

Noisy slip rings cause intermittent dark horizontal lines in the playback picture. To clean the slip rings, remove the upper drum cover on the top of the rotary-head drum assembly. Remove the tape from the tape path. Apply a few drops of SONY cleaning fluid to the slip rings. Turn on the motor for 10 to 20 seconds. Carefully wipe the excess fluid from the tape path around the rotary head-drum assembly. If slip ring noise persists, clean the slip rings directly with a head-cleaning tip saturated with SONY cleaning fluid. Rotate the

head assembly to keep the cleaning tip away from brushes.

Head degaussing:

Through constant use, the heads may become magnetized resulting in a noisy picture. Bring the tip of the degausser (SONY model HE-2) as close as possible to the head tip without contacting the head. Then remove the degausser very slowly at least three feet from the head, before turning off the degausser.

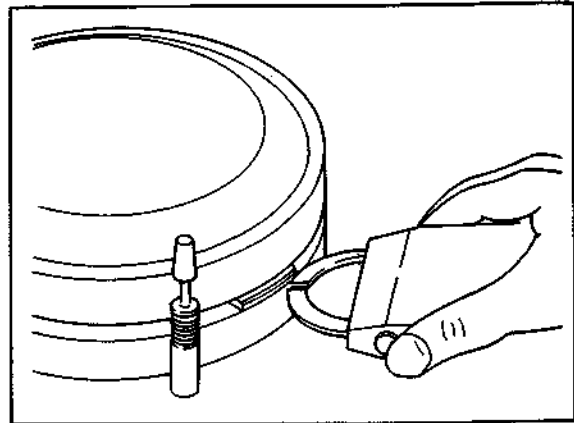

Fig. 7-3 Head degaussing

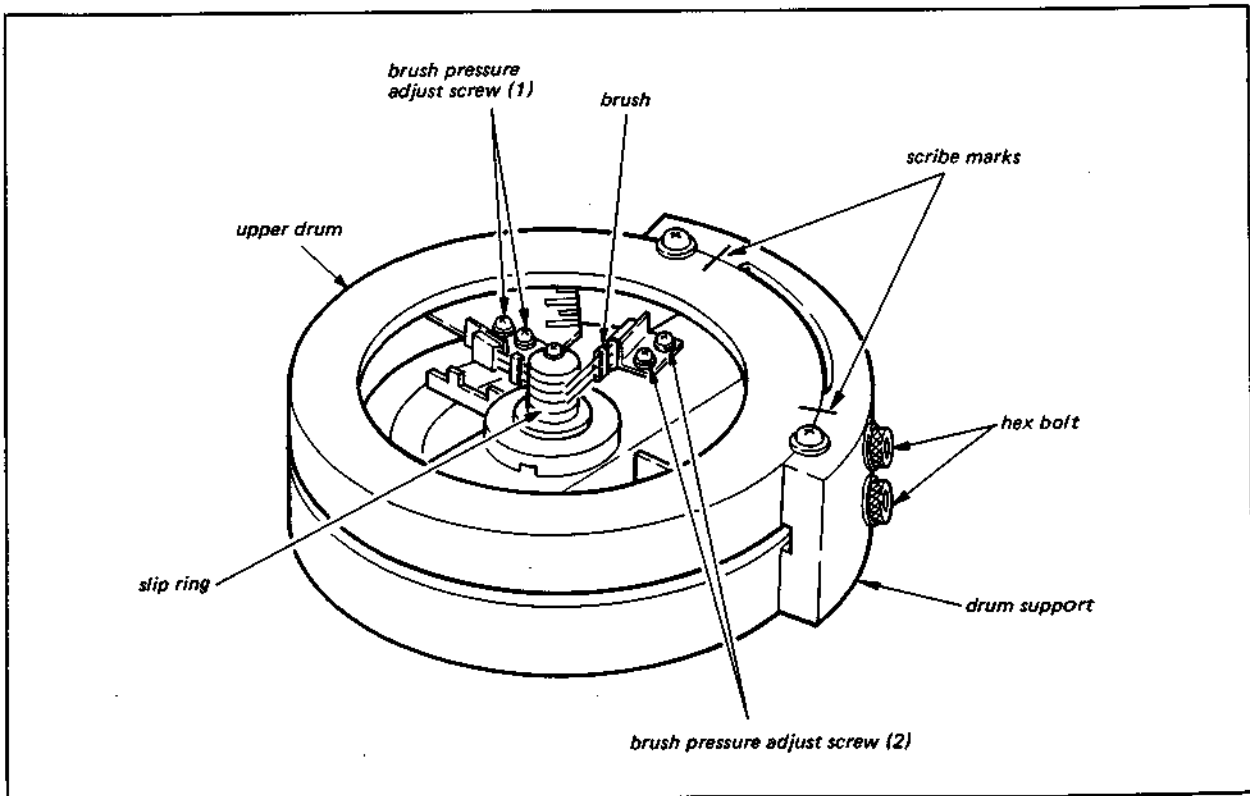

Fig. 7-4

CAUTION

THE HEAD DEGAUSSER SHOULD NOT BE ALLOWED TO TOUCH THE VIDEO HEAD.

7-3. VIDEO HEAD REPLACEMENT

Video head replacement is required when the heads are damaged, worn or have open coils. Check the video head output as indicated in Sec. 5-4-5.

CAUTION

THE VIDEO HEAD ASSEMBLY AND THE SURROUNDING MACHINED PARTS ARE VERY PRECISELY MADE. USE UTMOST CARE WHEN PERFORMING ANY WORK ON THE ROTARY HEAD-DRUM ASSEMBLY.

Removal

1. Loosen the screws that hold the head-drum cover. Lift off the head-drum cover.

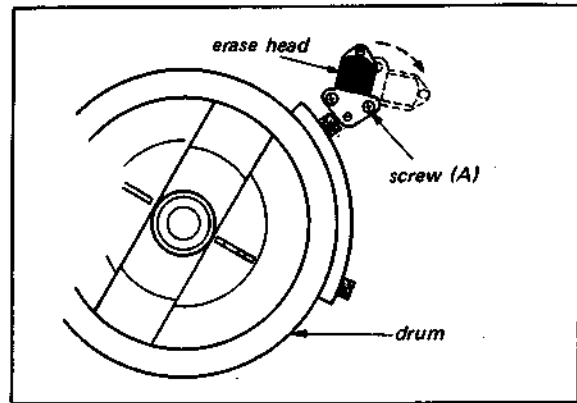

Fig. 7-5

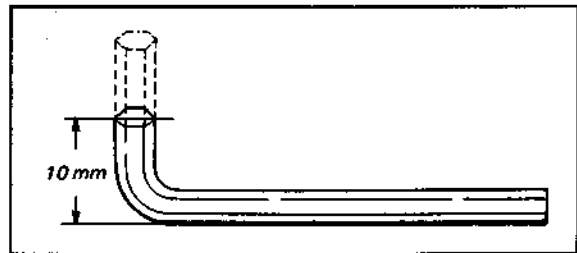

Fig. 7-6 4 mm Allen wrench

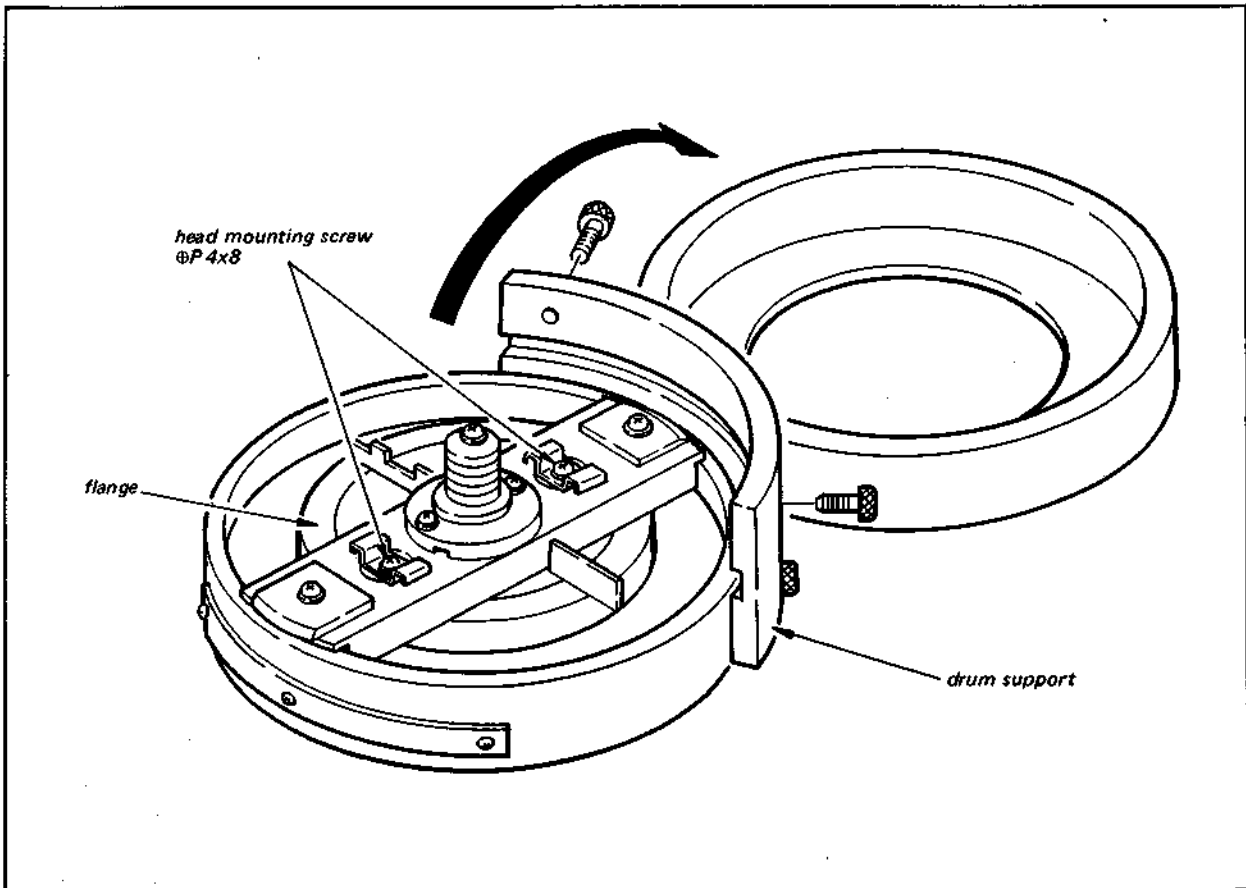

Fig. 7-7 Upper drum removal

2. Remove the two 3 mm screws that hold down the cover plate. Remove the cover plate.
3. Loosen the four brush pressure adjusting screws (1) and (2) as shown in Fig. 7-4 and move the brushes away from the slip rings.
4. Put a reference mark on the upper drum using a scribe and straight edge as shown in Fig. 7-4.
5. Remove the upper two Hexagon Socket Head Bolts 5 x 20 and washers as shown in Fig. 7-4 using a special 4 mm Allen wrench as shown in Fig. 7-6 or removing the erase head as shown in Fig. 7-5. Hold the upper drum with one hand so that it does not fall as you withdraw the two screws.
6. Carefully lift the top of the drum assembly and fold it back. Place the drum top carefully on the reel panel. See Fig. 7-7.

CAUTION

DO NOT TOUCH THE PG POLE PIECES.

Position the rotary head platform as shown in Fig. 7-7 by touching the aluminum beam on which the heads are mounted. Slight pressure on the pole pieces can affect pole piece alignment.

7. Hold the video head assembly to keep the platform from rotating. Loosen the two P 4 x 8 screws that hold the head assembly to the platform. See Fig. 7-7. Do not exert too much downward pressure on these screws. Remove the screws and washers.
8. Using both hands, carefully lift the video head assembly off the platform. If a spacer is found between the video head and aluminum beam, leave the spacer on the beam.

Replacement

9. Clean the bottom of the new video head, type H01-12 (SONY Part No. 8-946-912-00). This head is commonly used in all AV series VTRs.
10. Position the platform as shown in Fig. 7-8 so that the 25 PG pole piece is at the 3 o'clock position and the 50 PG pole piece is at the 9 o'clock position.

11. Carefully place the new video head assembly on the platform with the B head at the 6 o'clock position and A head at the 12 o'clock position. See Fig. 7-8. The head assembly should fit down snugly against the platform without using force.

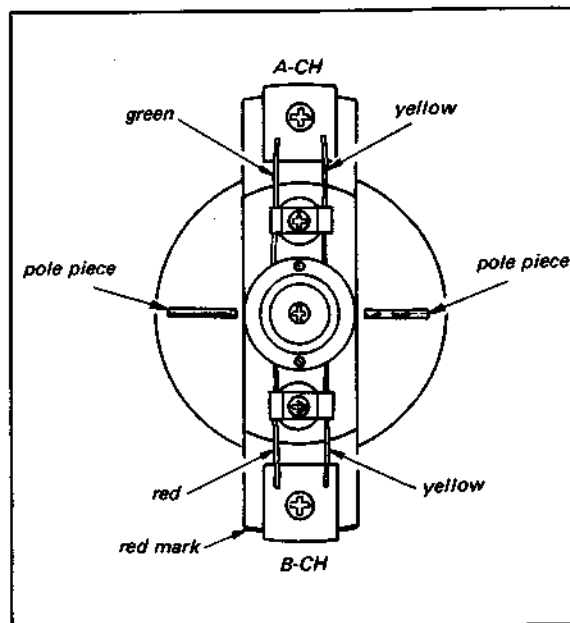

Fig. 7-8 Head mount

12. Install the two Pan head 4 x 8 mm screws and washers. Rotate the head assembly gently to the left and right until it is approximately in the center of the angular "play" permitted by the mounting screws. Tighten the screws alternately, applying torque gradually until the screws are tight.
13. Carefully swing the top of the upper drum back into place, support the top with one hand while inserting the two Hexagon-socket Head bolts and washers. Do not tighten the screws all the way.
14. Grasp the top of the upper drum to push it back and down against the drum holder so that the top surface of the upper drum is even with that of the drum holder. Align the scribe marks.
15. Tighten the two bolts alternately, applying torque gradually until all are tight.
16. Tighten the brush pressure adjusting screws to obtain a 2 mm bend (approximately) as shown in Fig. 7-9.

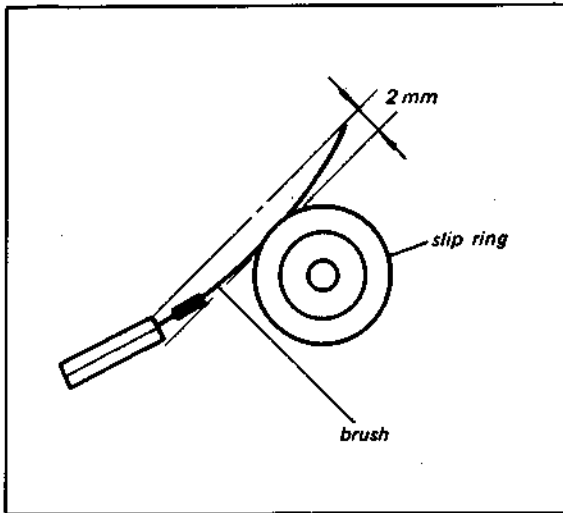

Fig. 7-9 Brush pressure

17. Inspect the brush and slip-ring assembly to make sure that the brushes are centered in the slip rings. If the brushes are not centered, loosen the brush position adjusting screws in Fig. 7-9 and apply drops of head cleaning fluid onto the slip-rings. Set up the playback mode to rotate the video heads. Adjust the position of the brushes so that they are centered in the slip-rings and tighten the brush-position adjusting screws.
18. If the erase head had been temporarily removed, install it in original position.

PG Check

19. After a new video head assembly has been installed, it is necessary to check PG outputs and their relative positions. See Sec. 4-3-3 and 4-3-4.

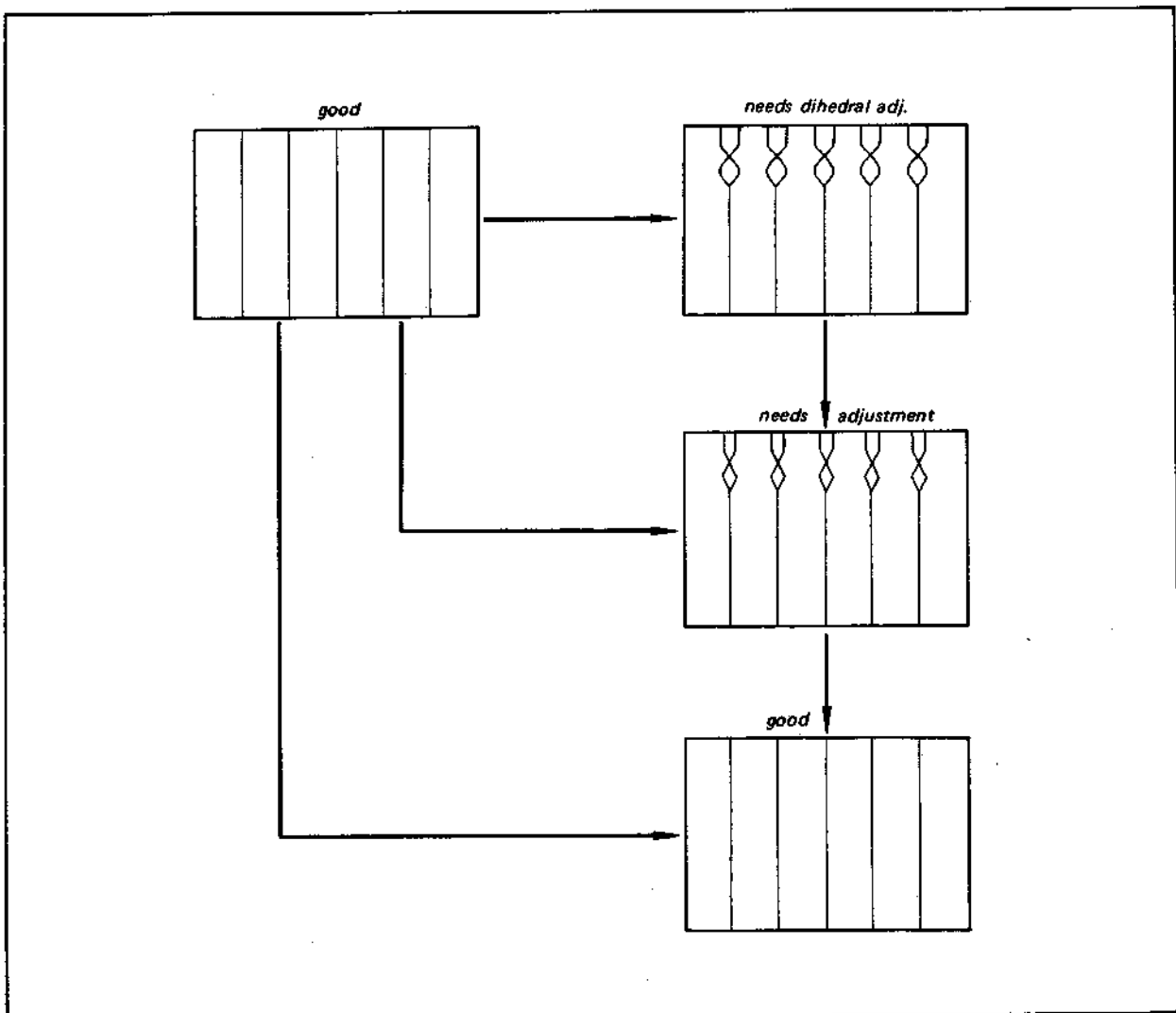

Fig. 7-10 Head dihedral adjustment

Preamplifier Check

20. It is also necessary to check the frequency response of the preamplifiers. See Sec. 5-9.

Dihedral Check

The two video heads should be positioned exactly 180 degrees apart. The relative angle can be measured by observing the monitor screen.

21. Play back the alignment tape.



Fig. 7-11 Head dihedral adjust screw

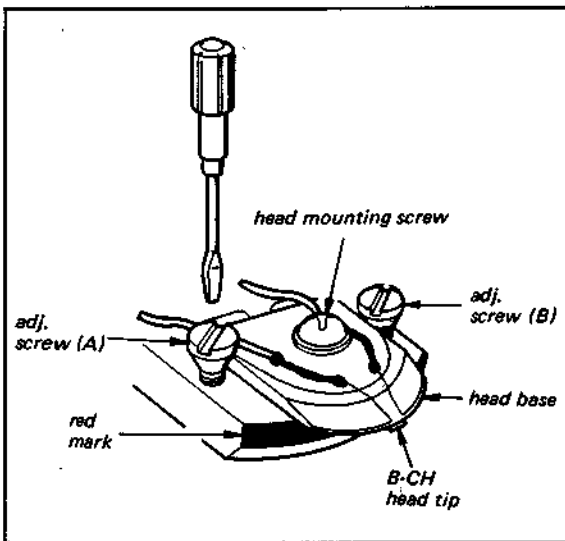

Fig. 7-12 Dihedral adjustment (1)

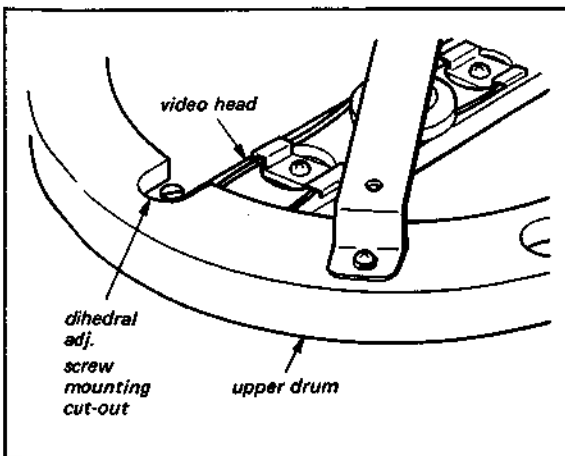

Fig. 7-13 Dihedral adjustment (2)

22. Observe the monitor screen, especially on the top edge, to see if there is any sync displacement as shown in Fig. 7-10. If this condition observed on the top, proceed to Step. 23.
23. Position the video head assembly as shown in Fig. 7-13. Install four angle adjustment screws (SONY Part No. 3-618-904-00) shown in Fig. 7-11 into both heads as shown in Fig. 7-12. Thread them in until slightly snug. Do not exert force.

CAUTION

DO NOT TOUCH HEAD MOUNTING SCREW.
See. Fig. 7-12.

24. Position B head (with red paint on the tip) to the adjusting position.
25. Turn (a) screw in Fig. 7-12 CCW $\frac{1}{4}$ turn and (b) screw CW $\frac{1}{4}$ turn.
26. Play back the video alignment tape again and observe the top of the picture. If the amount of displacement has decreased, repeat Step 25 until the displacement is invisible. If the amount of displacement has increased, proceed to Step 27.
27. Turn (a) screw in Fig. 7-12 CW by $\frac{1}{4}$ turn and (b) screw CCW by $\frac{1}{4}$ turn. Repeat Steps 26 and 27 until displacement becomes invisible.
28. Remove the four adjusting screws.

7-4. AUDIO/CONTROL HEAD REPLACEMENT

Replace audio/control head when it is worn, has open coils or is damaged. The head has the audio record/playback portion at the top, and the control-signal record/playback portion at the bottom.

1. Unsolder the leads at the rear of the head.
2. Remove the screws A and B in Fig. 7-14. Do not loosen the screws in the long slots.
3. Lift the head assembly off the mounting plate.
4. Place the new head assembly on the mounting plate and install the two screws from the bottom.
5. Install the head mounting plate assembly using the original screws A and B in Fig. 7-14.

6. Play the tape and check that the core of the head extends 0.1 mm above and 0.25 mm below the edges of the tape. See Fig. 7-15. The height can also be adjusted by inserting spacers.

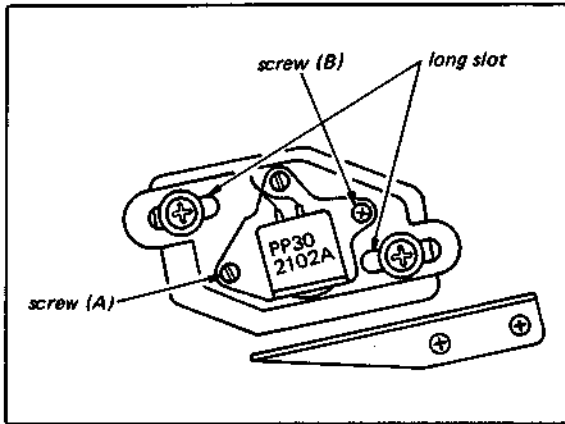

Fig. 7-14 Audio/CTL head (1)

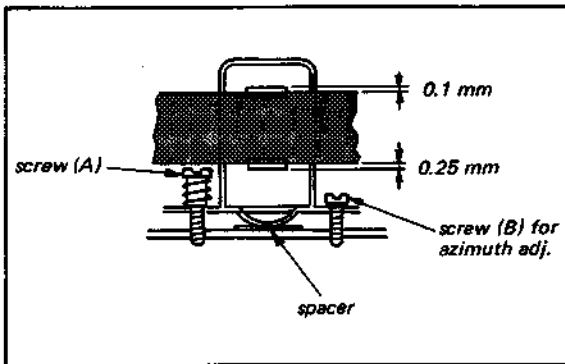

Fig. 7-15 Audio/CTL head (2)

7. Connect a VTVM to the EARPHONE jack.
8. Play back the 7 kHz section of the alignment tape.
9. Adjust the azimuth adjustment screw in Fig. 7-15 to obtain maximum VTVM reading.
10. Play back video alignment tape. Check the monitor picture for signal-to-noise ratio.
11. Adjust TRACKING control to obtain best picture. If S/N is poor, proceed to Step 12.
12. Connect scope to TP-7. Sync the scope externally from TP-19.
13. Play back video alignment tape. Loosen the screws in the long slots shown in Fig. 7-14.
14. Move the head slightly to the right or left until maximum output is obtained on scope.
15. Tighten the screws.

7-5. STOP BRAKE ADJUSTMENT

The tape should not slacken when the VTR is stopped from all other modes of operation, e.g. play, fast forward and rewind.

1. Remove reel panel.
2. Set the function lever to fast forward.
3. Check for 0.9 ± 0.1 mm clearance between the reel table and brake shoe. Bend (A) or (B) portion for correct clearance. See Fig. 7-16.

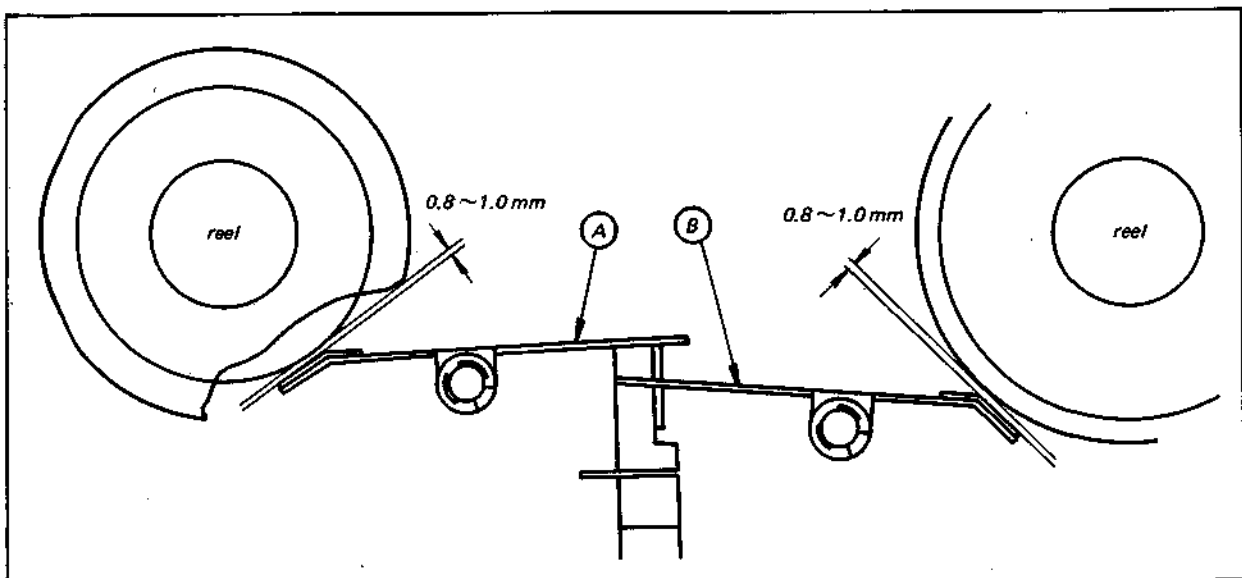

Fig. 7-16 Brake adjustment

7-6. PINCH ROLLER PRESSURE ADJUSTMENT

1. Make a loop in a piece of string and attach the spring scale around the base of the pinch roller shaft. See Fig. 7-17. Use 4 kg spring scale (SONY Part No. 9-911-042-01).
2. Set up playback mode.
3. Pull the scale in the direction indicated by the arrow in Fig. 7-17. Check the reading when the pinch roller leaves the capstan. It should be in between 1.4 kg and 1.55 kg. If not, proceed to Step 4.
4. Loosen four screws in Fig. 7-17. Move the solenoid downwards when the reading is too low. Tighten the screws.
5. Check for 0.1 ~ 0.5 mm clearance between the pressure base and pinch roller base. If not, bend \textcircled{D} with pliers.

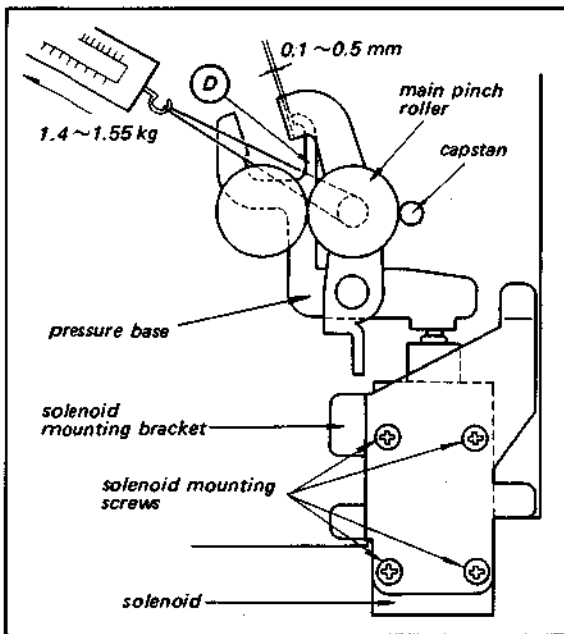

Fig. 7-17 Pinch roller adjustment

7-7. TAPE TENSION BRAKE CHECK

This adjustment corrects the back tension applied by the tension brake servo to the supply reel.

1. Place a full reel of tape on the supply reel table.
2. Make a loop in the tape and attach a spring scale as shown in Fig. 7-18. Use 400 g tension gauge (SONY Part No. 9-911-042-00).
3. Thread the tape in the path shown in Fig. 7-19.
4. Set up the playback mode (power off).
5. Pull the scale in the direction indicated in Fig. 7-19. A steady pull at approximately the correct speed should give a reading of $45 \text{ g} \pm 5 \text{ g}$.
6. If tape tension is other than $45 \text{ g} \pm 5 \text{ g}$, bend the spring stay shown Fig. 7-19.
7. Repeat Steps 5 and 6 until the tape tension is $45 \text{ g} \pm 5 \text{ g}$.

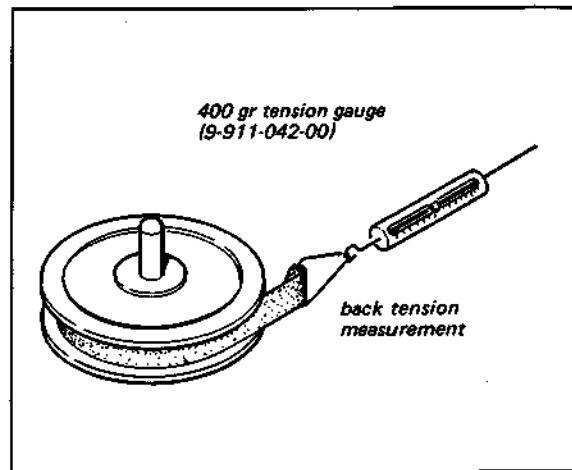

Fig. 7-18

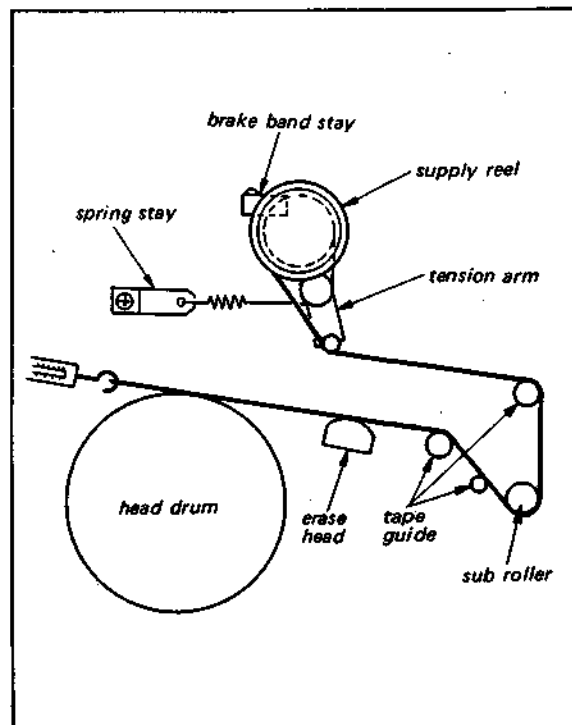

Fig. 7-19 Back tension measurement

7-8. FAST FORWARD PULLEY ADJUSTMENT

If fast forward cannot be set up correctly, adjust pulley position as follows.

1. Set up fast forward mode and check by hand how tightly the tape is wound onto the take-up reel.

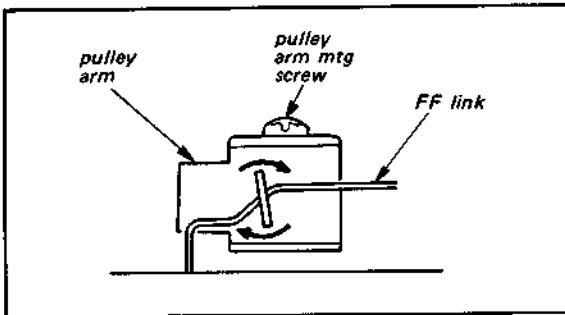

Fig. 7-21 Detail A

2. If the tape pack is too loose, bend the pulley arm in the direction indicated by arrow in Fig. 7-21. Use pliers.

7-9. TAKE-UP TORQUE ADJUSTMENT

If take-up torque is weak in the record and playback modes, adjust it as follows.

1. Place a full reel of tape on the supply reel table. Set up the fast forward mode so that almost all tape is wound onto the take-up reel.
2. Set up the playback mode and check the take-up torque.
3. If take-up torque is weak, turn the pulley pressure adjusting nut shown in Fig. 7-21 CW 2 to 3 turns.

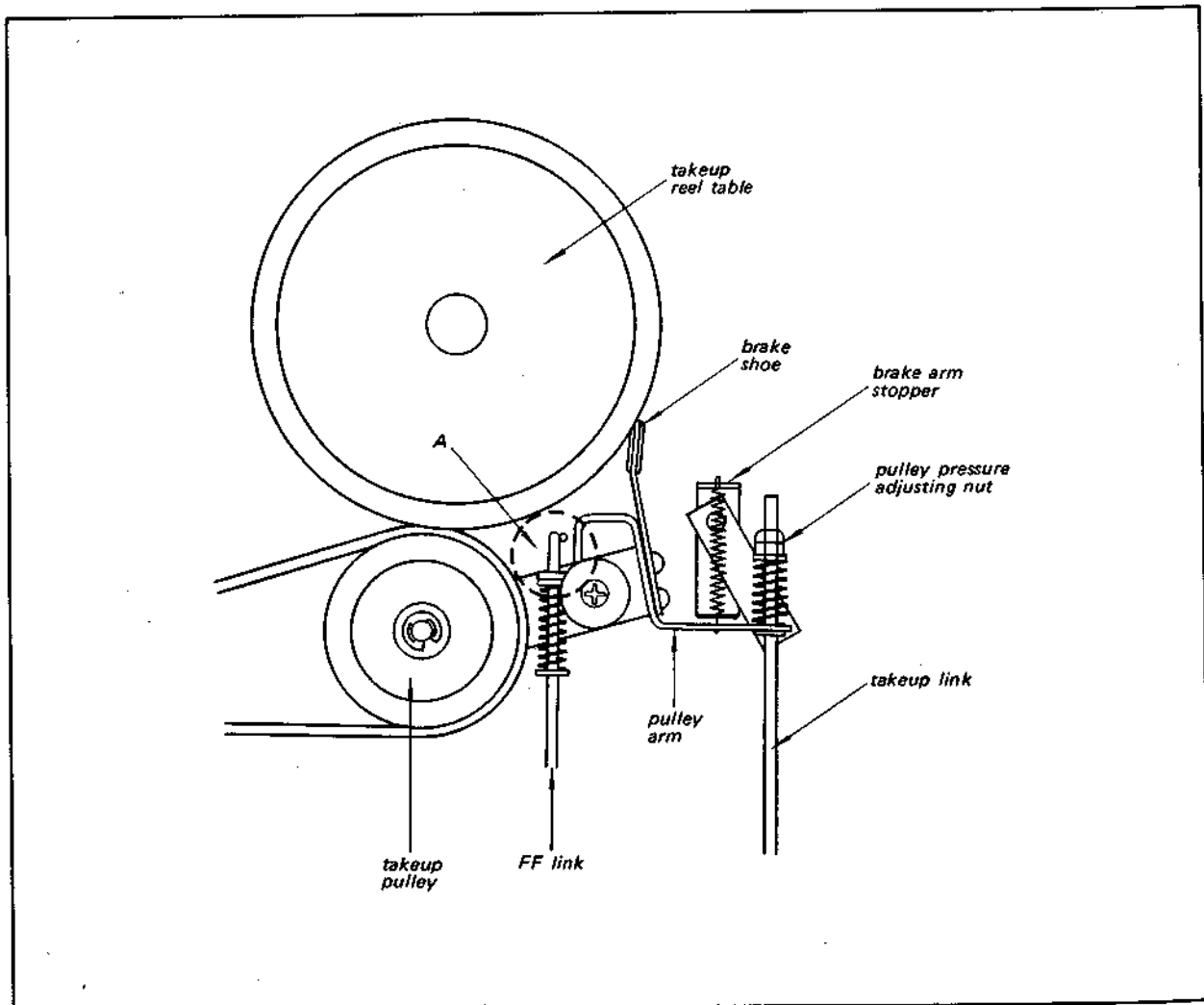

Fig. 7-20 Takeup pulley

7-10. SUB-MOTOR REPLACEMENT

1. Remove the cabinet. See Sec. 2-1.
2. Remove the front control panel by removing four screws shown in Fig. 7-22.

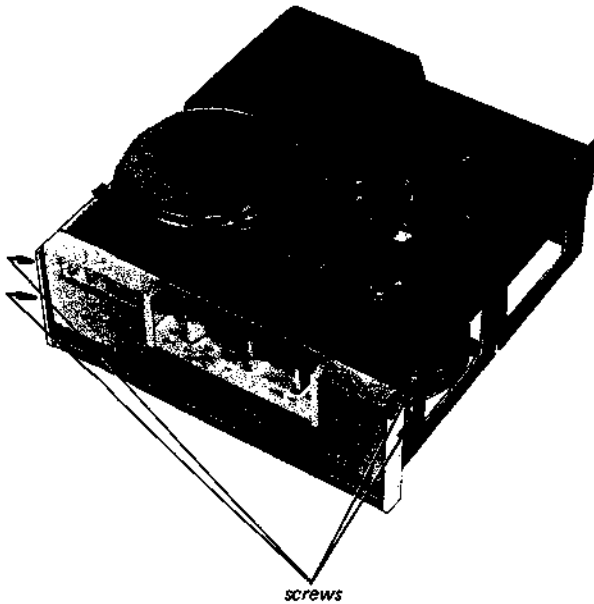

Fig. 7-22

3. Remove "V1" circuit board. See Sec. 2-2.
4. Remove the sub-motor belt and capstan belt from pulley.
5. Remove screws in Fig. 7-23 to take out the sub-motor assembly.
6. Remove (a) submotor bracket and (b) from sub-motor as shown in Fig. 7-23.
7. Prepare a new sub-motor.
8. Insert the pulley ass'y into the shaft of the sub-motor. Check the clearance between the

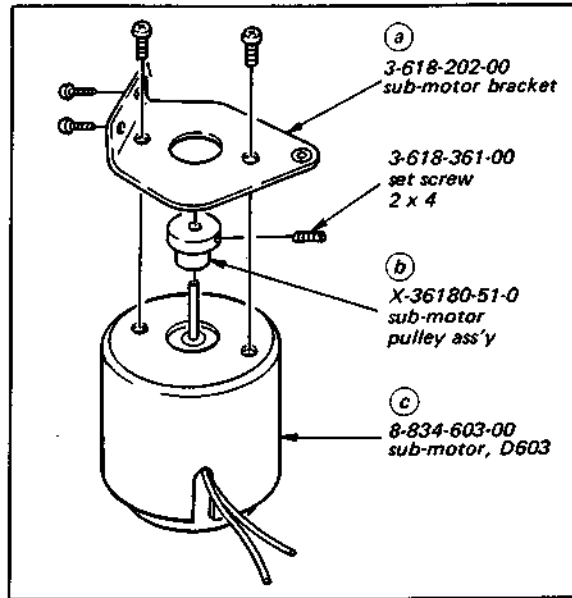

Fig. 7-23 Sub-motor assembly

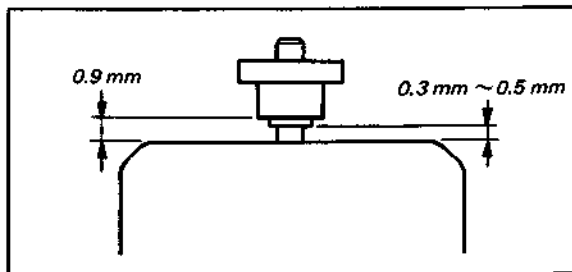

Fig. 7-24

9. Install the bracket shown in Fig. 7-23, and the belt.
10. Reinstall the sub-motor assembly into the chassis.
11. Reinstall the capstan belt.
12. Reinstall the "V1" circuit board and the front control panel.
13. Reinstall the cabinet.

SECTION 8 CIRCUIT DESCRIPTION

8-1. VIDEO CIRCUIT

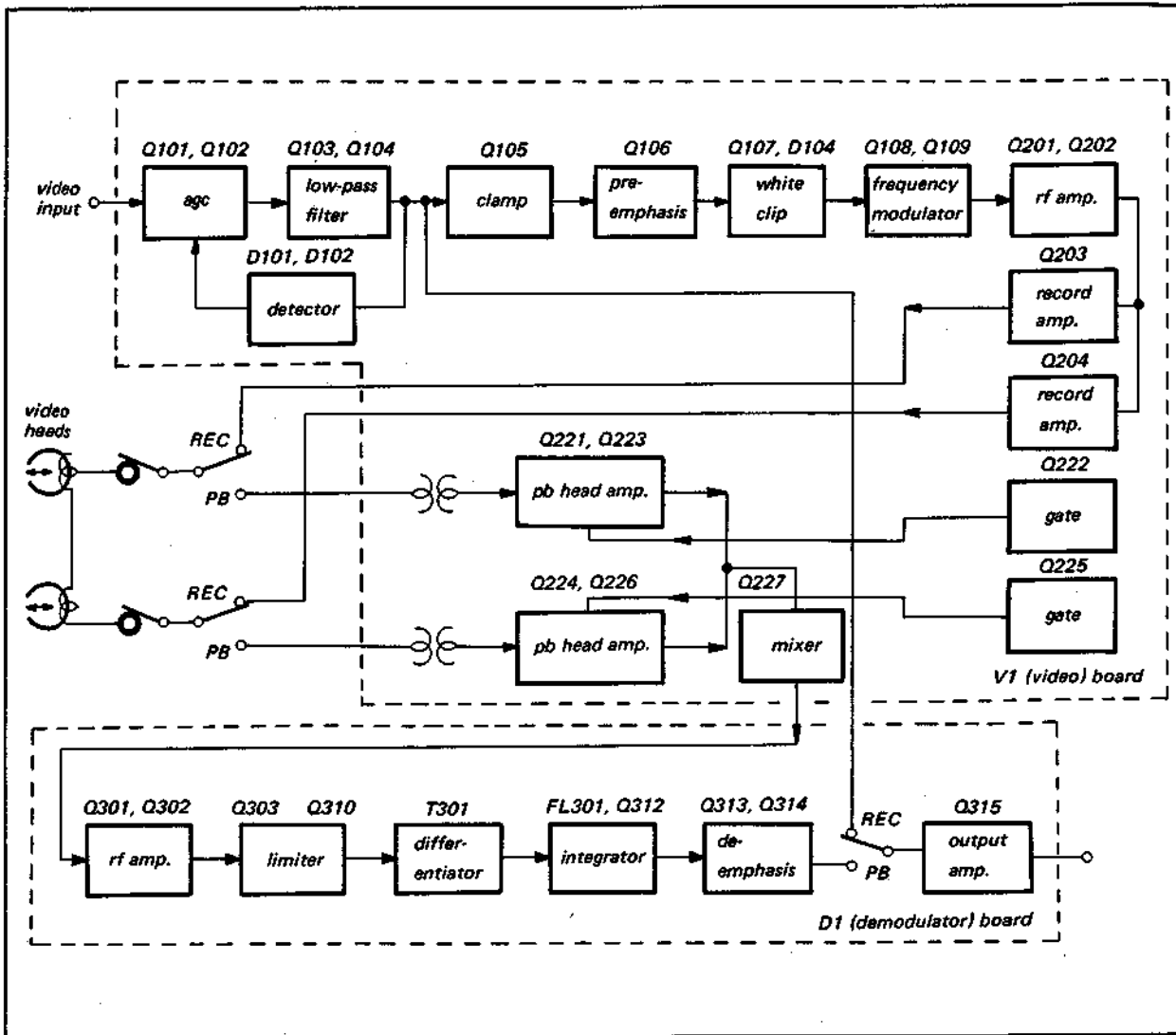

Fig. 8-1 Video system, block diagram

Video input and AGC
Q101 and Q102

The input video signal amplitude is held constant by an AGC system. Output from Q104 is sampled and detected by D101 and D102 in order to control the conduction of FET Q101. Q101 acts as a variable resistor.

Low-pass filter
L101, L102, C107

The 4.43 MHz color sub-carrier, 5.5 MHz sound carrier and other high frequency components are removed by this filter.

Video amplifier
Q103 and Q104

The amplified video is supplied to three outputs, the FM modulator, AGC detector, and

monitor output. Since the AV-3420CE has no E-to-E mode, record video is monitored at the output of Q104.

Clamp
D103, C112

The video signal is clamped by this circuit.

Differential amplifier
Q105 and Q106
Pre-emphasis
C114, R121, R122

The video signal, including the d-c level, is amplified by the differential amplifier with pre-emphasis provided for high frequencies.

White clip
D104

D104 clips the white peaks (overshoot) produced by the pre-emphasis network.

Frequency modulator Q108 and Q109 This is a symmetrical free-running multivibrator acting as a frequency modulator. The oscillating frequency varies from 3.8 MHz to 5.2 MHz in AV-CE Series Videocorders.

Coupling X' former T101 T101 couples the modulator output to the record amplifiers.

Record amplifier Q201 through Q204 These are power amplifiers to feed record current to the video heads. R201 adjusts record current. R209 and R211 adjust the frequency response characteristic.

Video heads A slip-ring and brush assembly couples recording current to the video heads.

Head amplifiers and switchers Q221 through Q227 The playback video head outputs are amplified and alternately gated on by the 25PG signal to provide a flat, noise-free output.

Video amplifier Q301 and Q302 The PB video head outputs are mixed in the base circuit of emitter follower Q227. The output of Q227 feeds a two stage video amplifier that provides middle-frequency peaking.

Limiters Q303 through Q310 The PB signal is amplitude-limited by four diode pairs with transistors supplying interstage amplification.

Demodulator D309, D310 The input to the demodulator from Q310 is differentiated by R335 and the primary wiring of T301. The push-pull output of T301 is applied to the pair pulse detectors (demodulator) D309 and D310. These diodes produce two negative output pulse per one input pulse. Thus, the carrier frequency is effectively doubled and placed outside the video band.

Low-pass filter FL301 The output of D309 and D310 is amplified by Q311 and fed to a low-pass filter to obtain a video output that is proportional to the pulse frequency.

Video amplifier Q312 and Q313 Video output from the low-pass filter is amplified by Q312 and Q313. R349 and C328 reduce high frequency gain to provide de-emphasis.

Noise eliminator Q314 Only the high frequencies are separated at Q314 input, amplified and sliced by D311/D312 diode pair. Noise eliminated high frequencies are then mixed with original signal at Q315 input.

Video amplifier Q315

8-2. SERVO CIRCUIT

The AV-3420CE has both a head-drum (scanner) servo and a capstan servo system. Section 8-2-1 describes the camera-record mode where the head drum servo free-runs at 13,125 Hz with the capstan servo disabled. Section 8-2-2 describes the TV-record mode where the capstan servo is locked to the external TV signal. Section 8-2-3 describes the playback mode where the capstan servo is locked to the playback control-track signal and the head drum servo runs at 13,125 Hz.

8-2-1. Camera-Record Mode Servo

In the camera record mode the servo system acts as a simple speed regulator to make the scanner turn at 25 rps. The reference for the system is a multivibrator having a constant pulse width.

Variations in speed, as detected by variations in the output frequency of the tone (feedback) generator, alter the duty cycle of this multivibrator to produce a dc correction voltage that controls motor speed. A belt linkage to the capstan drive pulley provides tape driving power. The capstan servo is not operative in the camera record mode.

When using the AVC-3420CE, the Videocorder free-runs at a constant speed, and supplies vertical and horizontal drive signals to the camera. The head drum contains a dc servo motor with a 13,125 Hz frequency generator beneath it. Faster rotation of the head produces a generator output higher than 13,125 Hz which lowers the dc motor drive current and thus slows the head rotational speed.

13,125 Hz Frequency Generator FG The head drum contains a frequency generator coil that produces 525 Hz output pulses per single revolution of the video

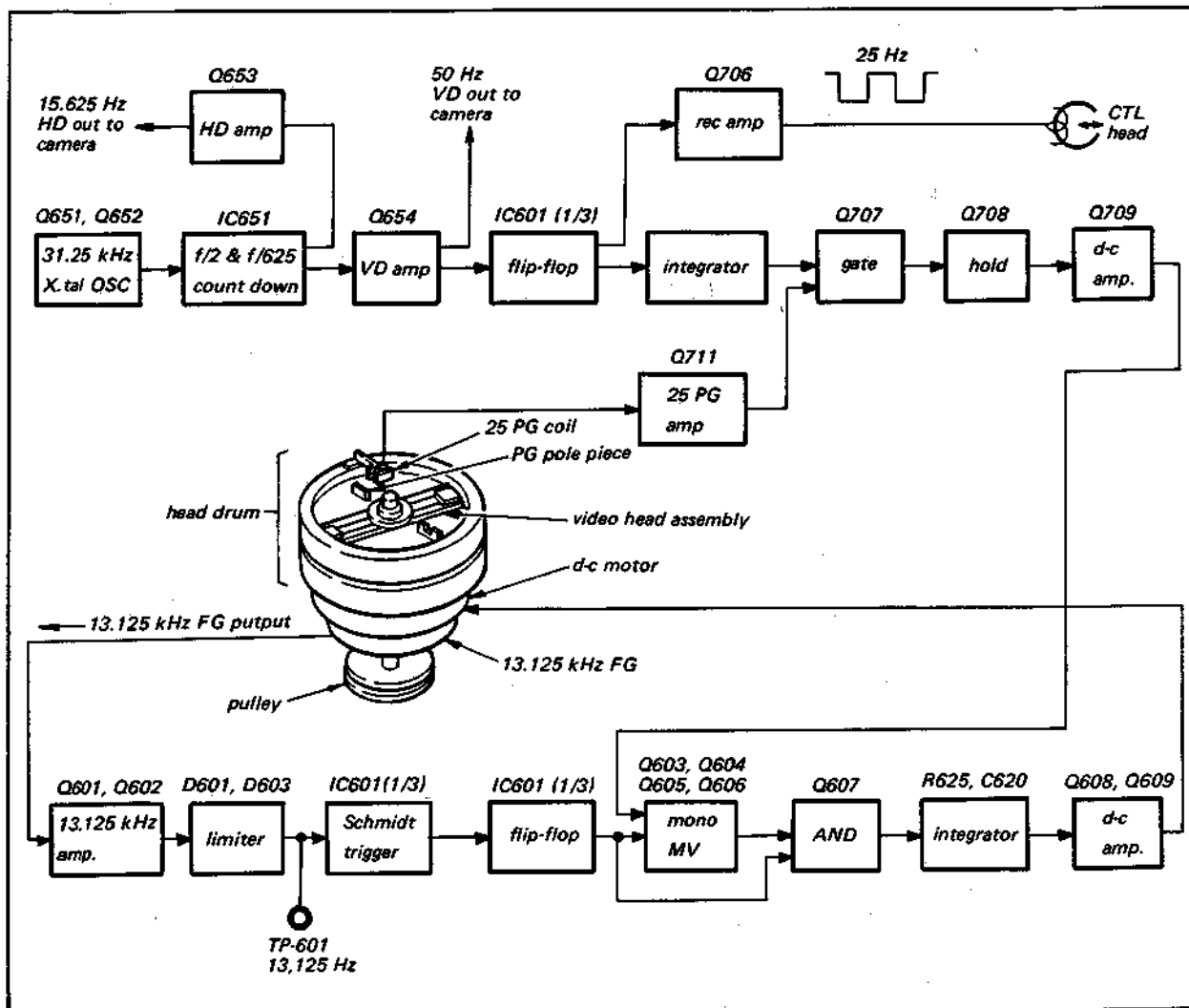

Fig. 8-2 Camera record mode, block diagram

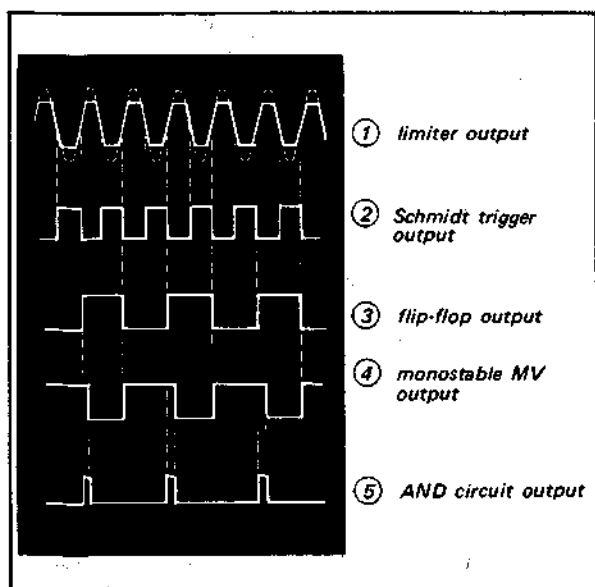

Fig. 8-3. Servo waveforms

head. The head rotates at 25 rps. so that the frequency generator coil produces a 13.125 Hz output. Faster rotation increases FG frequency output and slower rotation decreases frequency output.

FG amplifier (Q601, Q602) and limiter (D601, D602)

The 13.125 Hz FG output is amplified and then amplitude-limited so that it can drive the following Schmidt trigger circuit.

Schmidt trigger IC601(1/3)

IC601(1/3) comprises a Schmidt trigger circuit that converts FG output to rectangular pulses.

Flip-Flop IC601(1/3) The flip-flop is triggered by the negative slope of the Schmidt output so that the 13,125 Hz frequency is halved to 6562.5 Hz rectangular pulses.

Monostable MV Q603, Q604, Q605 and Q606 The positive slope of the monostable multivibrator is triggered by the negative slope of the flip-flop output. The negative slope of the multivibrator is determined by potentiometer R621 so that the ON period of the multivibrator is always held constant by R621. Since the ON period of the flip-flop varies with the head rotational speed whereas the ON period of the multivibrator is always held constant, the error signal is obtained by comparing the flip-flop output and multivibrator output.

AND gate Q607 The monostable multivibrator output (Fig. 8-3-4) and the flip-flop output (Fig. 8-3-3) are fed to an AND gate, Q44, that conducts only when the monostable multivibrator and the flip-flop are ON at the same time. The duration of the AND gate output pulse depends on the speed of head rotation. If head rotation is too fast, the flip-flop output pulse will have a short period as compared with the constant monostable multivibrator output pulse. The AND gate output will then have a long pulse duration.

Integrator R625, C620 The AND gate output is converted to a dc level by the integrator circuit.

31.25 kHz X'tal OSC Q651, Q652 This is a conventional crystal controlled oscillator operating as a sync generator for camera.

f/2, & f/625 count down IC651 An IC type MN-116 receives 31.25 kHz input and provides f/2 (15,625 Hz) and f/625 (50 Hz) for camera drive.

Flip-flop IC601(1/3) Divides the 50 Hz VD pulse to 25 Hz rectangular pulse.

Integrator R728, C723 The rectangular pulse is integrated so that both positive and negative edges have a slope determined by the RC time constant.

Gate Q707 The integrator output is sampled by the 25PG pulse to obtain the servo error signal.

Hold Q708 The sampled signal charges C725 until next sampled signal comes in. Q708 has the high input impedance so that C725 charge will not be discharged during gate is closed.

Dc amp Q709 Error signal between the VD and 25PG is represented by dc signal that is supplied to the reference multivibrator that is made variable so that head disc scanner and camera deflection is locked in.

8-2-2. TV Record Mode Servo

In the TV record mode the same servo system is used to drive the scanner except that the master crystal oscillator signal is replaced by the separated TV sync. The capstan servo is not operative in the TV record mode.

Sync separator Q704 This is a conventional sync separator with a short time constant bias network (R713 & C712) to remove impulse-type noise.

Low-pass filter C715, C716 Removes horizontal, sync pulses from the vertical sync interval.

Flip-flop IC601(1/3) Divides the 50 Hz vertical sync pulse to a 25 Hz rectangular pulse.

Integrator R728, C723 The rectangular pulse is integrated so that both positive and negative edges have a slope determined by the RC time constant.

Gate Q707 The integrator output is gated by the 30PG pulse to obtain the servo error signal.

Dc amplifier Q709 The error signal is amplified by Q707, and fed to the monostable multivibrator (Q603 ~ Q606) so that the error signal can vary the time constant of the monostable multivibrator.

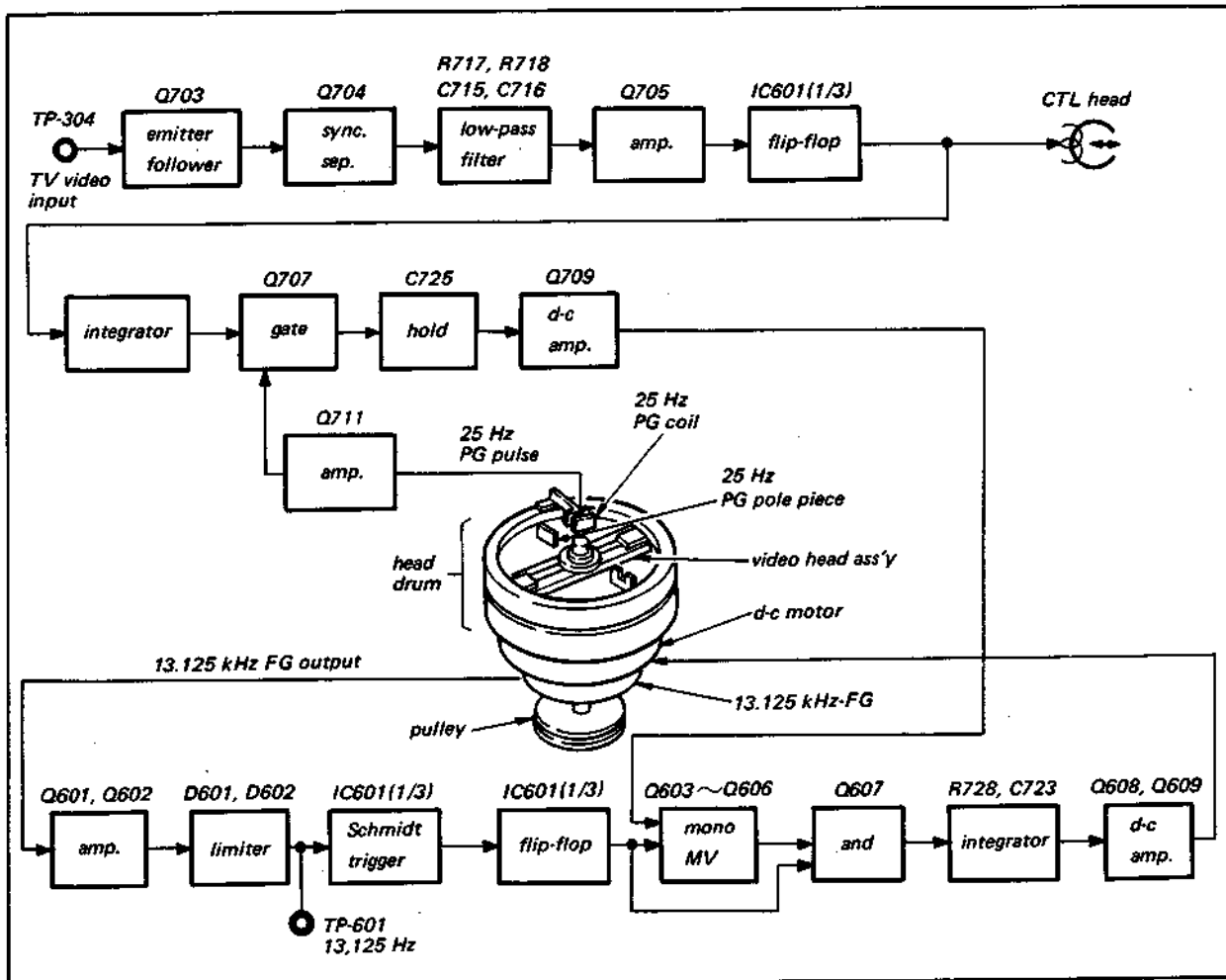

Fig. 8-4. TV record mode servo, block diagram

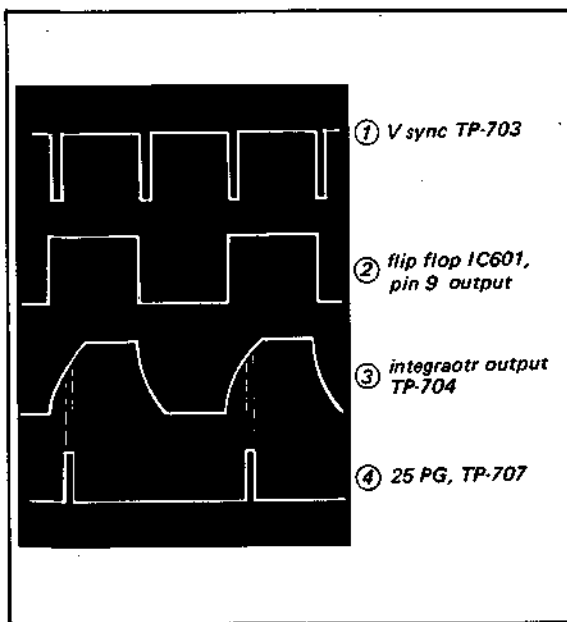

Fig. 8-5. Servo waveforms

8-2-3. Playback Mode Servo

In the playback mode, both the scanner and capstan servo systems are operative. The scanner servo functions in the same way as it does in all other modes; it is a simple speed regulator. However, the capstan servo driven to ensure correct tape position is servo driven to ensure correct tape position as the head begins its pass across the tape. To do this the arrival of the CTL pulse is compared with the arrival of the feedback. 25PG pulse. The resulting dc error voltage drives the capstan sub motor to speed up or retard tape motion. The 25PG pulse is compared with stable master oscillator VD output to stabilize the 25PG rotation.

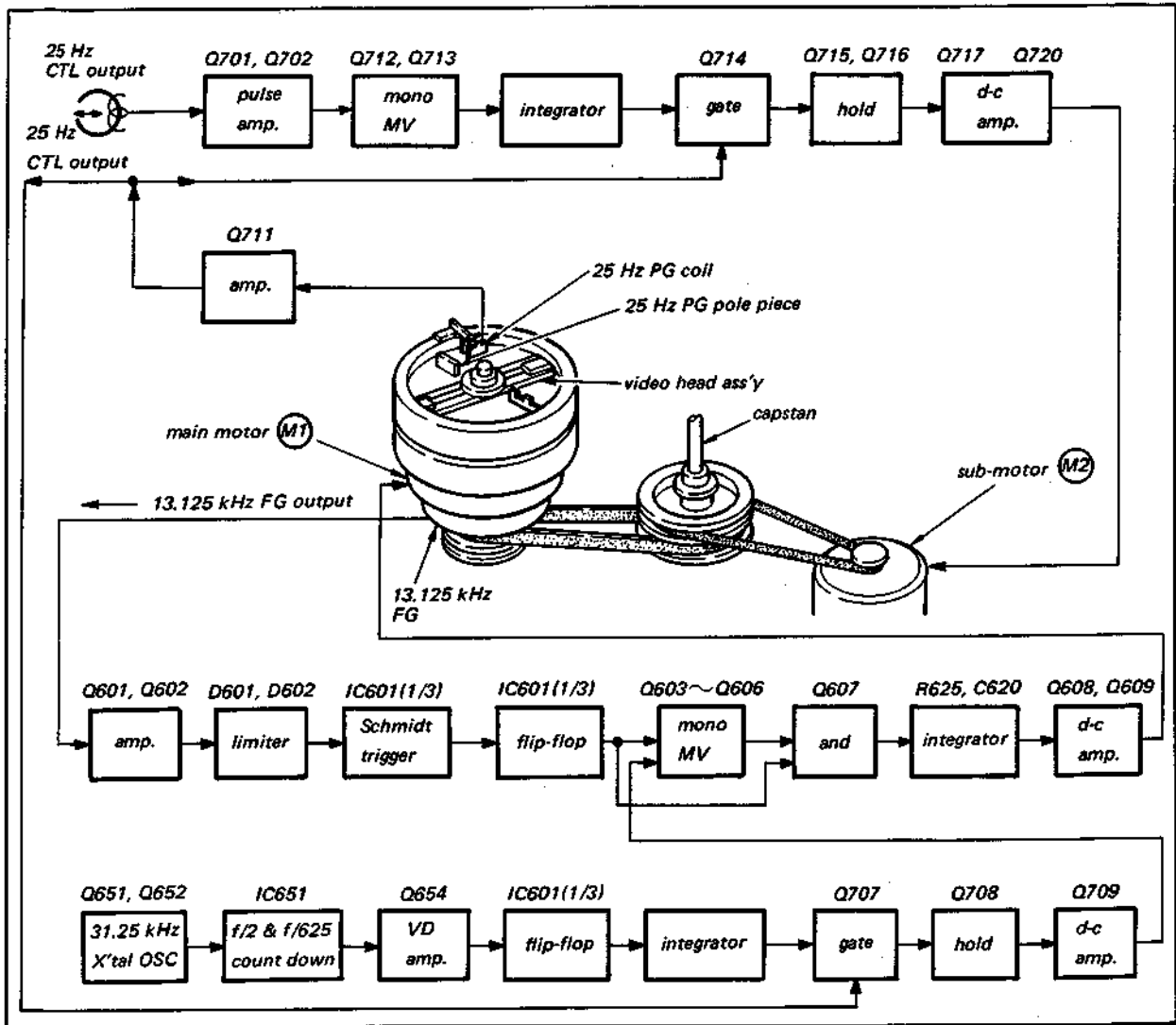

Fig. 8-6. Playback servo block diagram

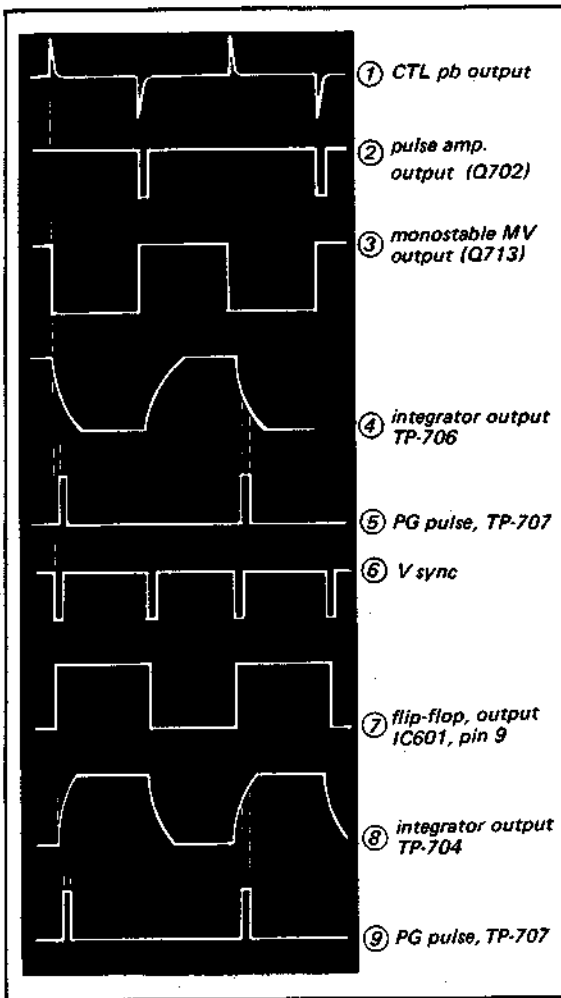

Fig. 8-7. Playback servo waveforms

Pulse amplifier
Q47, Q48

Negative-going pulses from the CTL head are amplified by Q47 and Q48.

Monostable Multivibrator
Q54, Q55

This multivibrator is triggered by the negative slope of the playback CTL signal.

Dc amplifier
Q57, Q59 ~ Q62

This push-pull amplifier is connected in a Darlington configuration to supply either accelerating or braking current to the motor in playback.

8-3. AUDIO CIRCUIT

This section describes audio record, playback, and sound dub circuits.

8-3-1. Record Mode Audio Circuit

Audio recording level is maintained by the AGC circuit. The audio recording may be monitored at the EARPHONE jack only in the TV record mode.

Audio input from either the microphone or the TV is amplified by Q801 and Q802 with negative-feedback equalization. The output of Q802 is again amplified by Q803 and fed then to the audio record/playback head through a bias trap. The agc circuit consists of Q804 through Q807 to detect and supply negative feedback to Q802.

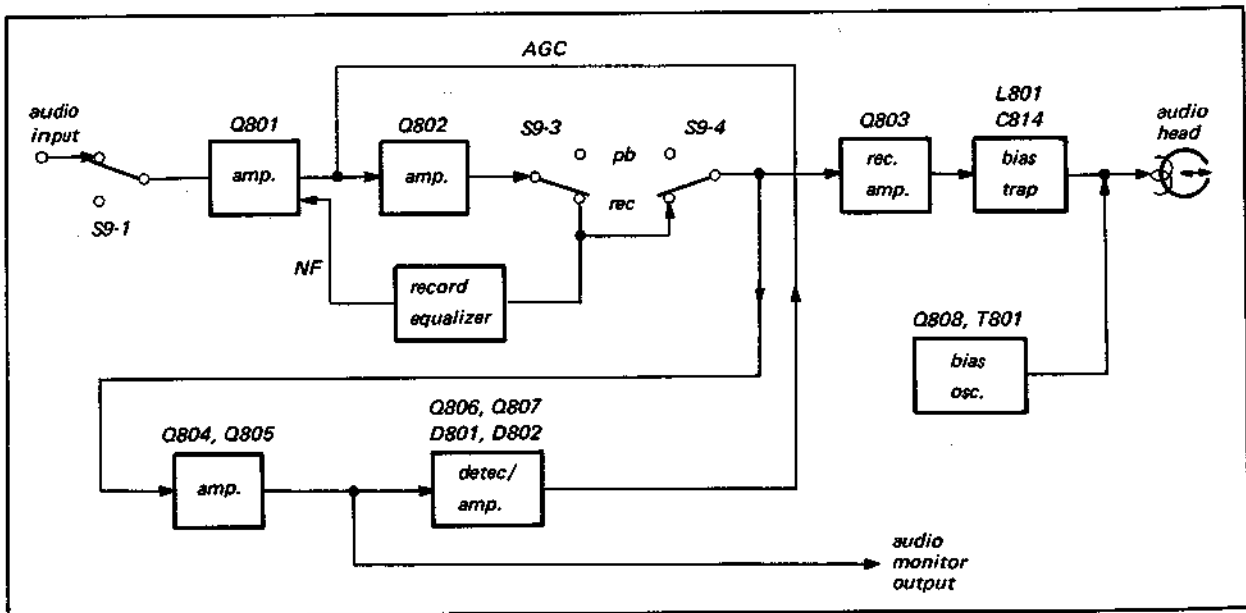

Fig. 8-8. Record mode audio circuit

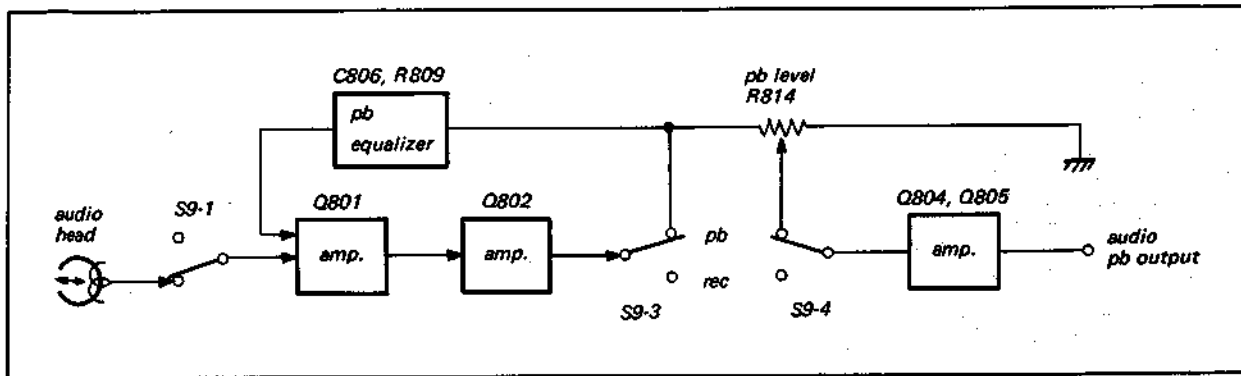

Fig. 8-9. Playback mode audio circuit

8-3-2. Playback Mode Audio Circuit

Playback audio output is supplied to the RF modulator and the monitor/TV in the TV mode, while it is supplied to only the RF modulator in the camera mode.

The playback signal from the audio head is amplified by Q801, Q802, Q804 and Q805, and then supplied to the audio output. C806 and R809 provide negative feedback.

8-3-3. Audio Dub Mode Circuit

In the audio dub mode, the video circuits remain in the playback mode while the audio circuit is in record. The erase current normally fed to the video heads is by-passed to a dummy load L803 so that an equal amount of erase current is fed to the audio erase head in both normal record and audio dub modes.

8-4. POWER SUPPLY

The internal BP-20 battery or an external power supply (AC-3420CE) supplies dc power of 12 V ~ 13 V between Pin 2 (hot) and Pin 4 (ground) of CN3. Current passes through a 3A fuse, automatic shut-off switch S10, and a series regulator power supply (Q901 Q903) to provide a B+ of 9 V dc.

The battery meter is connected between +12V dc and +9V dc. The meter pointer stays in the boundary region between red and white areas when +12V input drops to +11V dc.

8-5. CAMERA REMOTE CONTROL CIRCUIT

The Videocorder has a camera remote control circuit consisting of Q951 through Q955 that is connected to the AVC-3420CE trigger lever micro-switch through camera connector CN1. Dc +12 V power is supplied from Videocorder to the camera through CN1 pin 10. When camera trigger lever is switched on, +12 V is fed back to Z board D951 anode through CN1 pin 6 to conduct Q951, Q952, Q954 and Q955 to energize solenoid.

SECTION 9 TAPE TRANSPORT DESCRIPTION

9-1. TAPE PATH

The tape path is shown in Fig. 9-1.

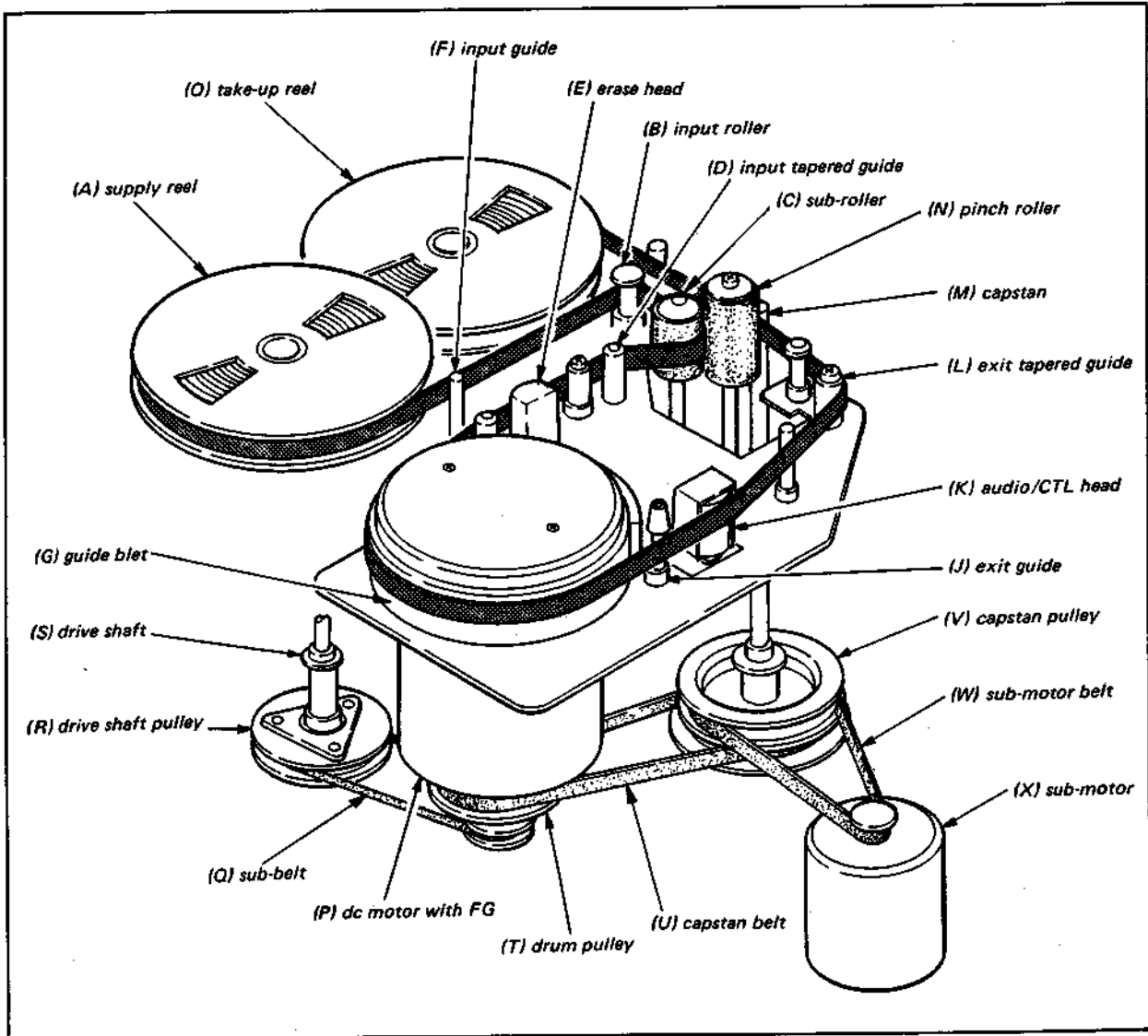

Fig. 9-1 Tape path

The tape, placed on the Supply Reel Table (A), takes a path as shown in Fig. 9-1 and is wound onto the Take-Up Reel Table (O).

The tape on the Supply Reel Table (A), is first fed to the Input Roller (B) and Sub-roller (C) where the approximate height of tape is determined. The tape is then slanted by about 3 degrees by Input Tapered Guide (D). The tape then contacts the full-track erase head. The Input Guide (F) determines the tape height precisely. The tape runs around the circumference of the head drum 180

degrees along the Guide Belt (G). The Exit Guide (J) also determines the tape height. The audio signal is recorded and played back by the upper core of the audio/CTL head (K). The control track signal is recorded and played back by the lower core. The tape is again slanted by the Exit Tapered Guide (L), and squeezed by the Capstan (M) and the Pinch Roller (N) before it is wound onto the Take-up Reel Table (O).

The Head Drum has a built-in dc motor that provides torque to rotate both the Video Head and the Capstan. The Video Head assembly is connected to the shaft of the dc motor. Torque is transmitted to the Capstan (M) via Drum Pulley (T) and the Capstan Belt (V). Torque is also used to drive the Take-up Reel Table (O) via the Drive Pulley (R) and the Drive Shaft (S). The Sub-motor (X) and the Sub-Motor Belt (W) are used in the playback mode for the capstan servo system.

The Head Drum also has a built-in 13,125 Hz frequency generator coil, 25PG coil, and 50PG coil. The relative position of the video heads and the PG coils is shown in Fig. 9-2. Two output pulses from the 50PG coil, 1 pulse from the 25PG coil, and 625 cycles from the 13,125 Hz FG coil are obtained for each revolution of the video heads; 50 Hz, 25 Hz and 13,125 Hz are obtained at 25 revolutions per second.

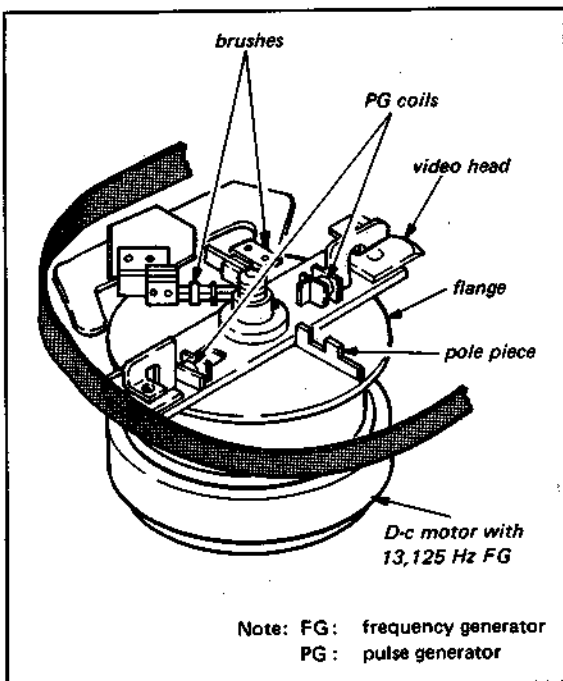

Fig. 9-2 FG and PGs

9-2. TAPE TRANSPORT IN PLAYBACK MODE

The tape transport in the playback mode is described in four sections: Brake System (See 9-2-1), Pinch Roller Mechanism (See 9-2-2), Tape Take-Up System (See 9-2-3) and Tension Control System (See 9-2-4).

9-2-1. Brake System

The brakes applied to the Supply and Take-Up Reel Tables in the stop mode are released in the play mode. See Fig. 9-3.

Setting the function lever from stop to play rotates the Function Select Cam counterclockwise. The pin shown at (A) pushes the Brake Release Slide Plate in the direction indicated by the arrow, actuating the two Brake Levers to release Supply and Take-Up Reel Table braking.

9-2-2. Pinch Roller Mechanism

Pinch Roller pressure is applied against the Capstan when the Solenoid is energized. Refer to Fig. 9-3. When power is applied to the Solenoid, the plunger moves in the direction indicated by the arrow, rotating the Pinch Roller Pressure Plate clockwise and thus compressing the Pressure Spring. This causes Pinch Roller Lever (A) to rotate clockwise, forcing the Pinch Roller against the Capstan.

9-2-3. Tape Take-Up System

Drive is transmitted from the Head Motor to the Take-Up Reel as described below. Refer to Fig. 9-1. The Sub-Belt transfers drive from the Drum Pulley on the Head Motor to a Drive Shaft Pulley on the Drive Shaft. The Take-Up Belt and Take-Up Pulley couple drive torque to the Take-Up Reel.

9-2-4. Tension Control System

A simple mechanical servo is employed to provide tape tension control. See Fig. 9-3.

Tape passes around the outside of the Tension Arm. A Band Brake, anchored at the pivot of the

Tension Arm by a screw, contacts the Supply Reel Table to exert a force inversely proportional to that applied at the Tension Arm. Thus, with no tape on the machine (no force applied to the Tension Arm), the Tension Arm is in its fully clockwise position and full band braking is applied to the Supply Reel Table.

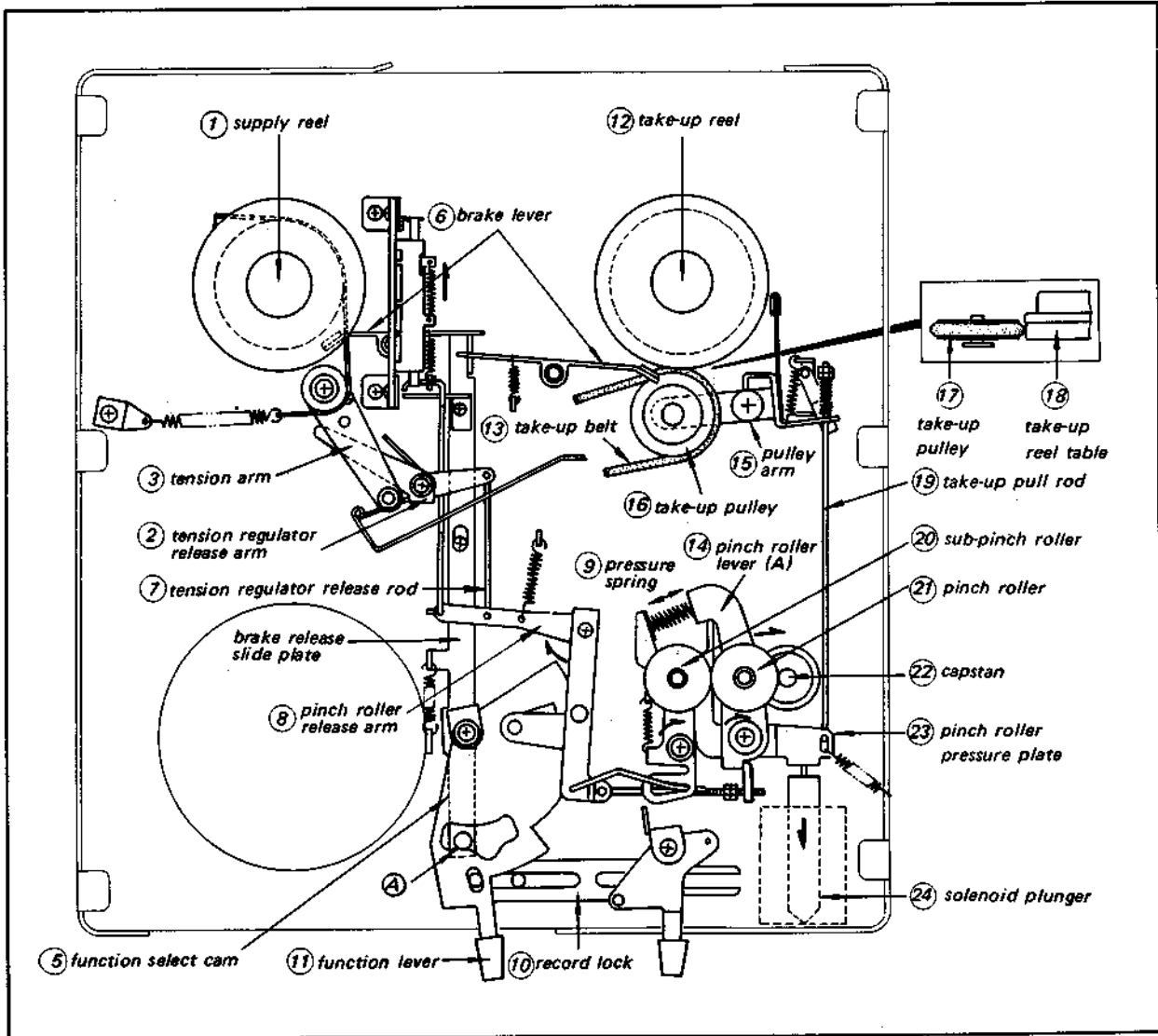

Fig. 9-3 Forward mode tape transport

9-3. INSTANT STOP MECHANISM

Instant stop in the playback mode is obtained by releasing the Pinch Roller from the Capstan. See Fig. 9-4.

When the Instant Stop Knob is pulled in the direction indicated by the arrow, the Instant Stop Slide Plate is pulled down, rotating the Instant Stop Lever clockwise about its pivot. The end of the Instant Stop Lever operates a pin on Pinch Roller lever (A) which forces Pinch Roller Lever (A), with the Pinch Roller, to pivot slightly counterclockwise away from the Capstan.

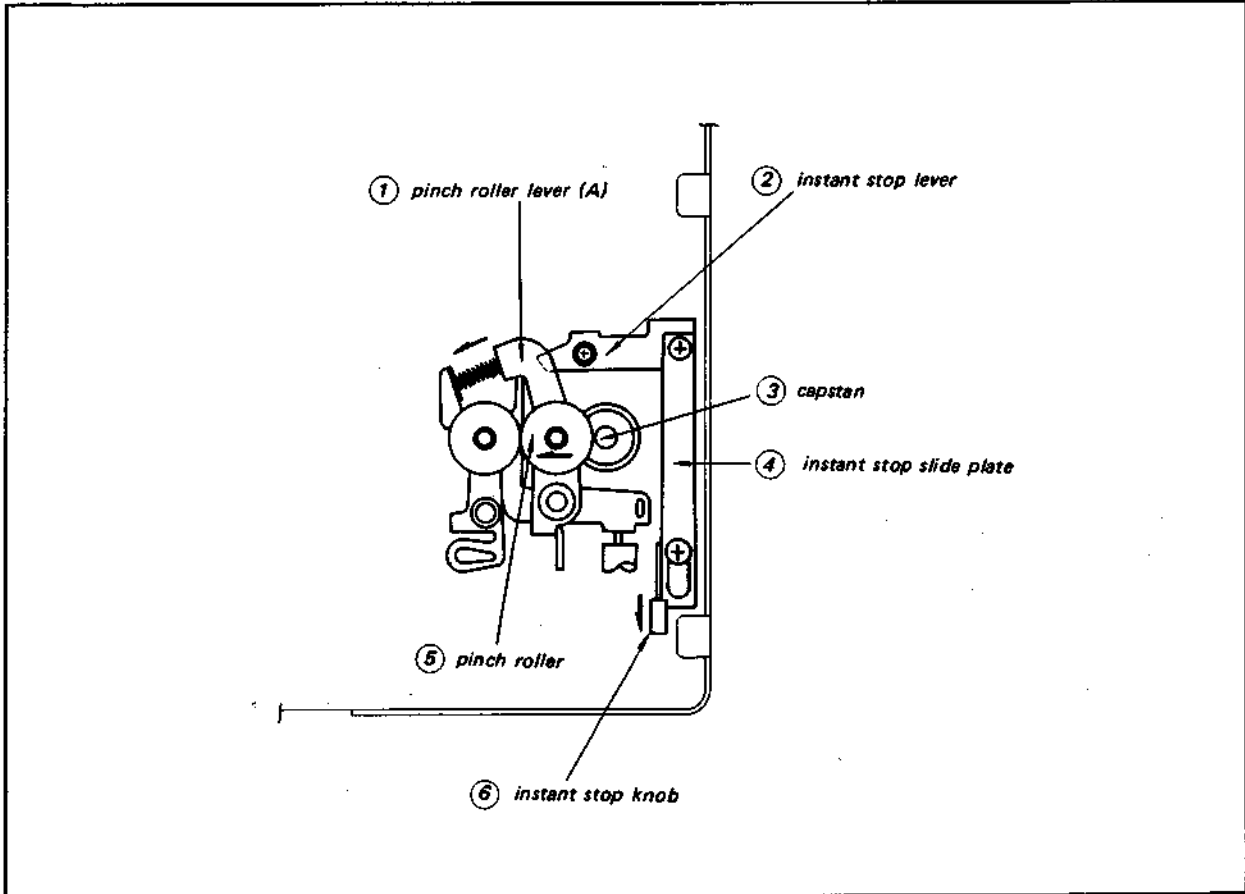

Fig. 9-4 Instant stop mode mechanism

9.4. TAPE TRANSPORT IN THE RECORD MODE

The tape transport operates the same in the record mode as it does in the play mode except that the record switches on the audio, video and servo boards are actuated. Refer to Fig. 9-5.

The Record Lever actuates the Record Plate on the audio board (at **A** in Fig. 9-5) and also the Record Link Rod, which pivots the Record Link Arm slightly clockwise. This permits two Record Link Levers, both under tension from a common spring, to pivot in opposite directions, thus actuating the slide switches on the servo and video boards (at **B** and **C**, respectively).

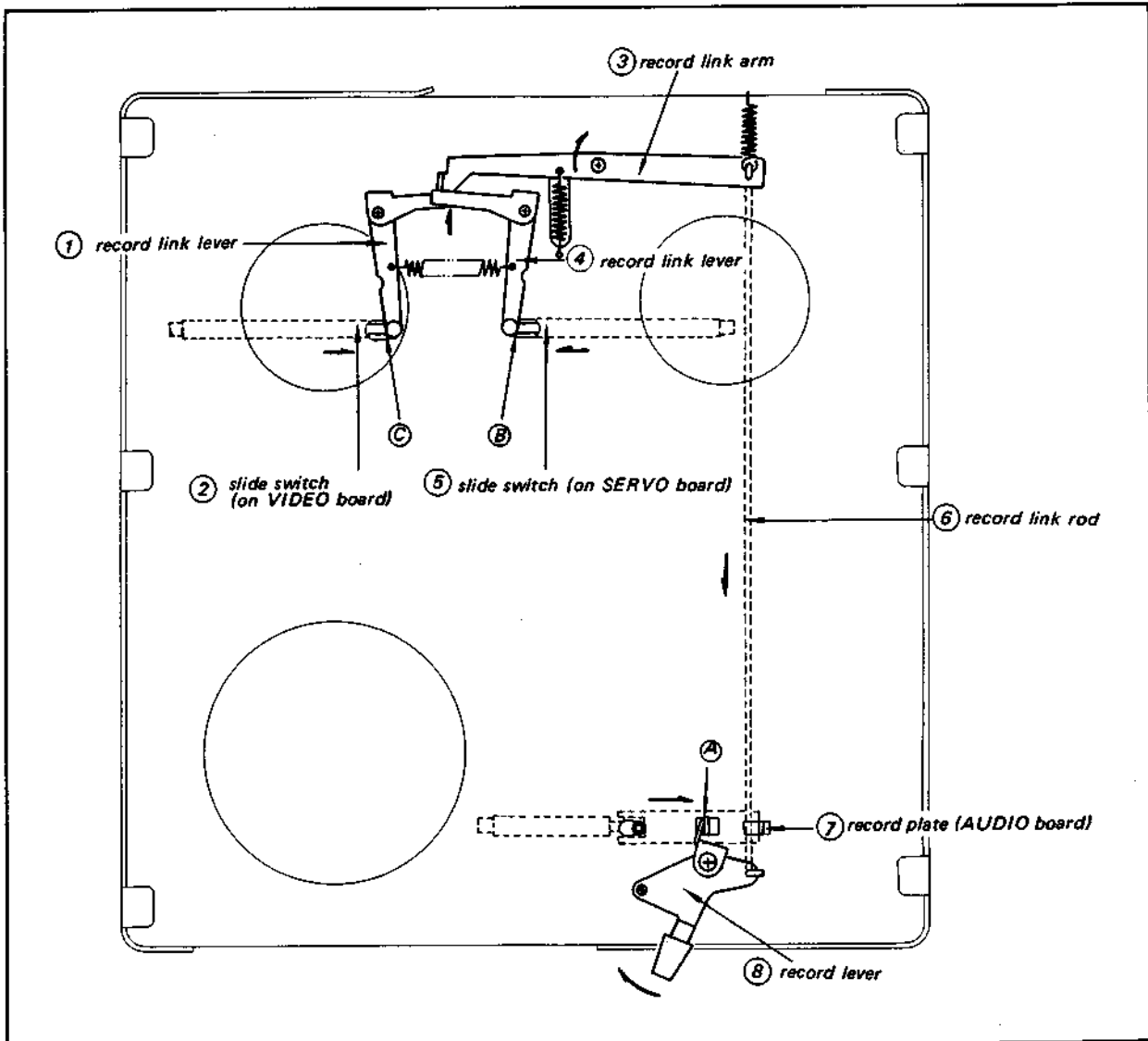

Fig. 9-5 Record mode mechanism

9-5. AUDIO DUB MECHANISM

The audio dub mechanism may be operated only in the play mode. See Figs. 9-3 and 9-5.

The Audio Dub Knob pushes the Audio Dub Slide Plate in the direction indicated by the arrow, rotating the Audio Dub Lever clockwise to actuate the Record Plate at (A). The Audio Dub Slide Plate also switches S5 via the Audio Dub Rod. (S5 switches dummy coil L803 in place of the full-track erase head.)

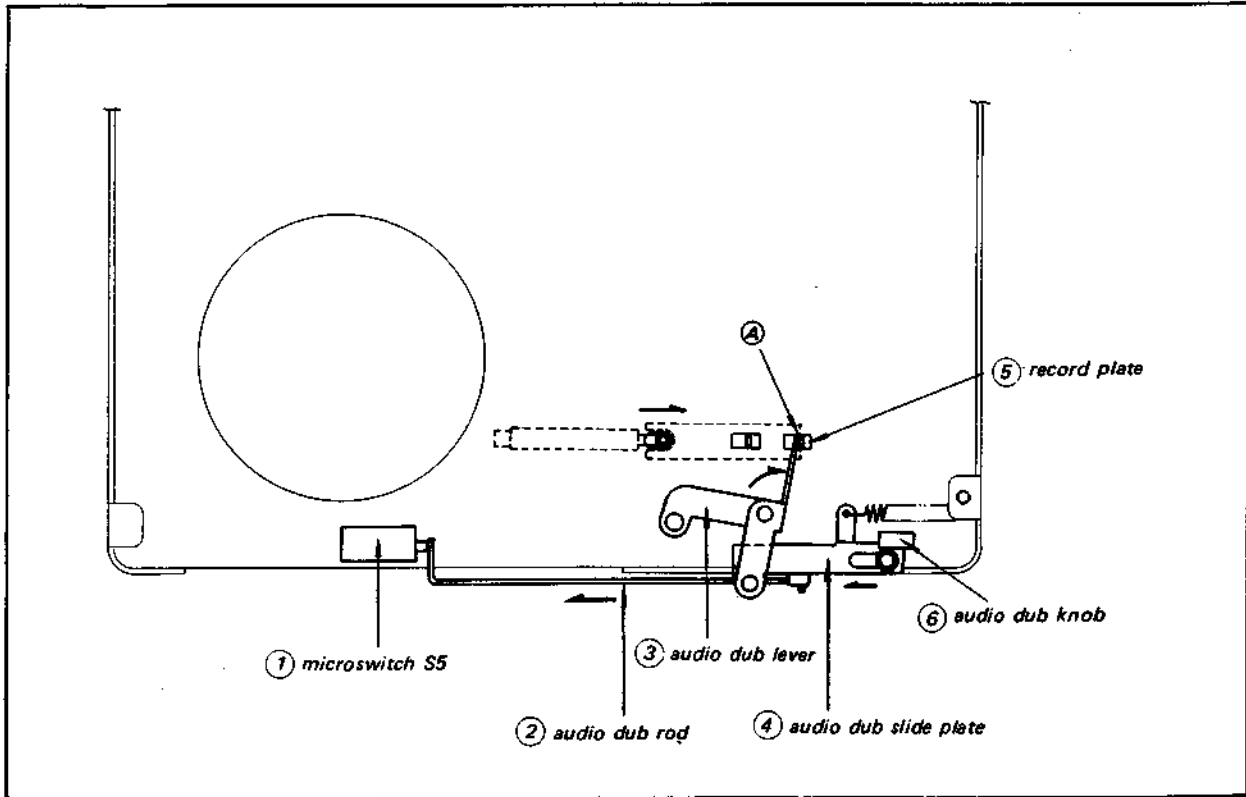

Fig. 9-6 Audio dub mechanism

9-6. TAPE TRANSPORT IN THE FAST-FORWARD MODE

In the fast-forward mode full take-up torque is applied to the Take-Up Reel Table and the Tape Tension Servo is released. The fast-forward mode is shown in Fig. 9-7.

9-6-1. Take-Up Reel Table Drive

When the function lever is set to fast forward, the Function Select Cam is turned to its fully counterclockwise position, pushing the FF Push Rod in the direction indicated by the arrow. The end of the FF Push Rod pushes up the Pulley Arm so that the Take-Up Pulley supplies drive to the Take-Up Reel Table.

9-6-2. Tape Tension Servo Release

When the Function Select Cam is rotated fully counterclockwise, as above, the FF Sub Cam is rotated counterclockwise, rotating the Pinch Roller Release Arm counterclockwise at (B). The Tension Regulator Release Rod, connected at the center of the Pinch Roller Release Arm, is pulled down, pivoting the Tension Regulator Release Arm slightly clockwise. This rotates the Tension Arm counterclockwise at (C), thus releasing the Band Brake. The Switch Push Rod, connected at the end of the Pinch Roller Release Arm, is pulled down at the same time and actuates S4.

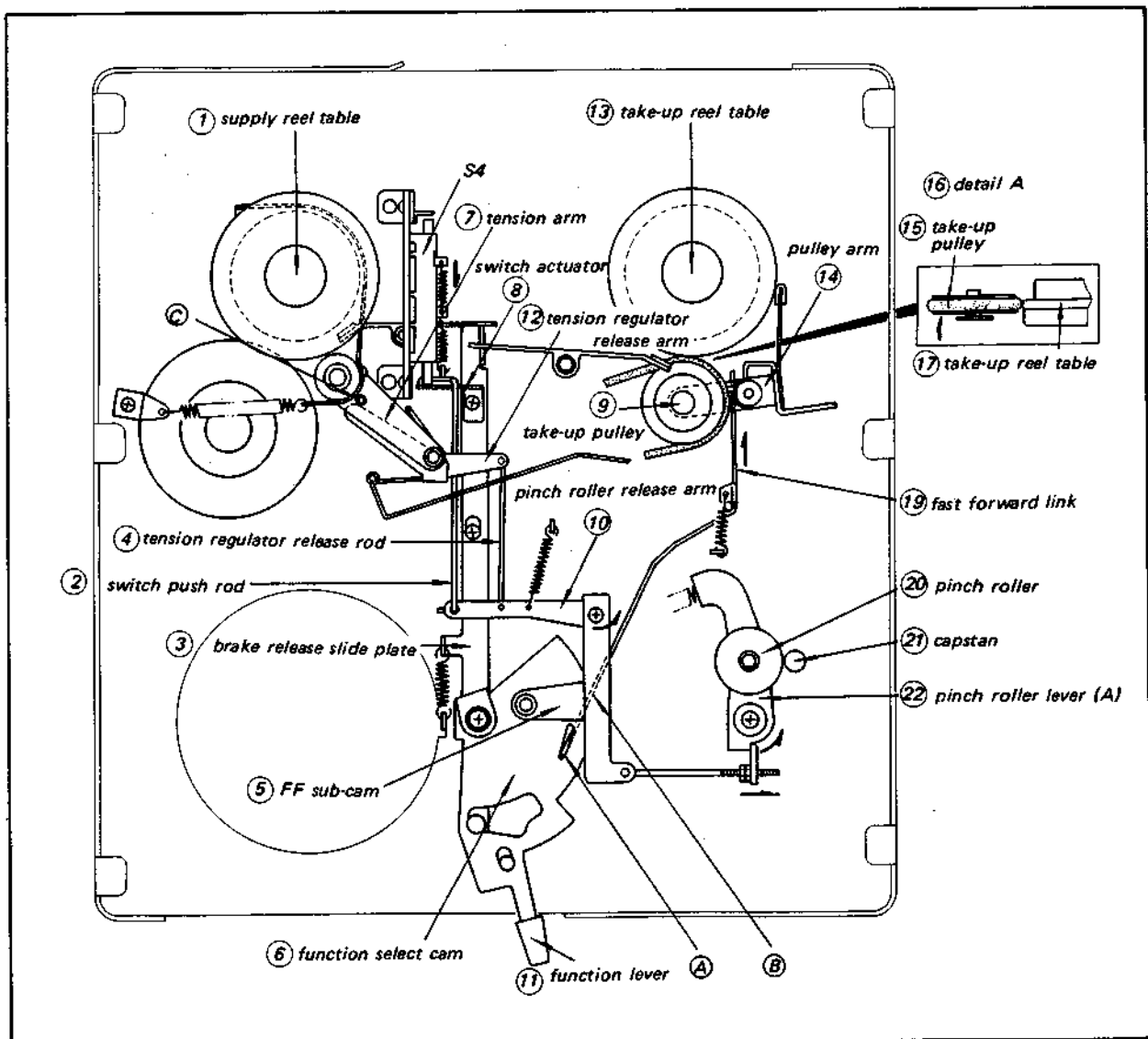

Fig. 9-7 Fast forward mode tape transport

9-7. TAPE TRANSPORT IN THE REWIND MODE

Full torque is applied to the Supply Reel Table to rewind the tape. The Stop Brakes are released from both the Supply and Take-Up Reel Tables. See Fig. 9-8.

Setting the function selector to the rewind mode rotates the Function Select Cam to its fully clockwise position. Rewind Release Lever (1) is rotated clockwise as it follows the detent of the FF Sub Cam at (A), pulling the Rewind Release Rod in the direction indicated by the arrow, to rotate Rewind Release Lever (2) clockwise. This releases the Rewind Slide Plate and allows a rewind idler to contact the Take-Up Belt (at C) and the Take-Up Reel Table (at D) to transmit driving torque.

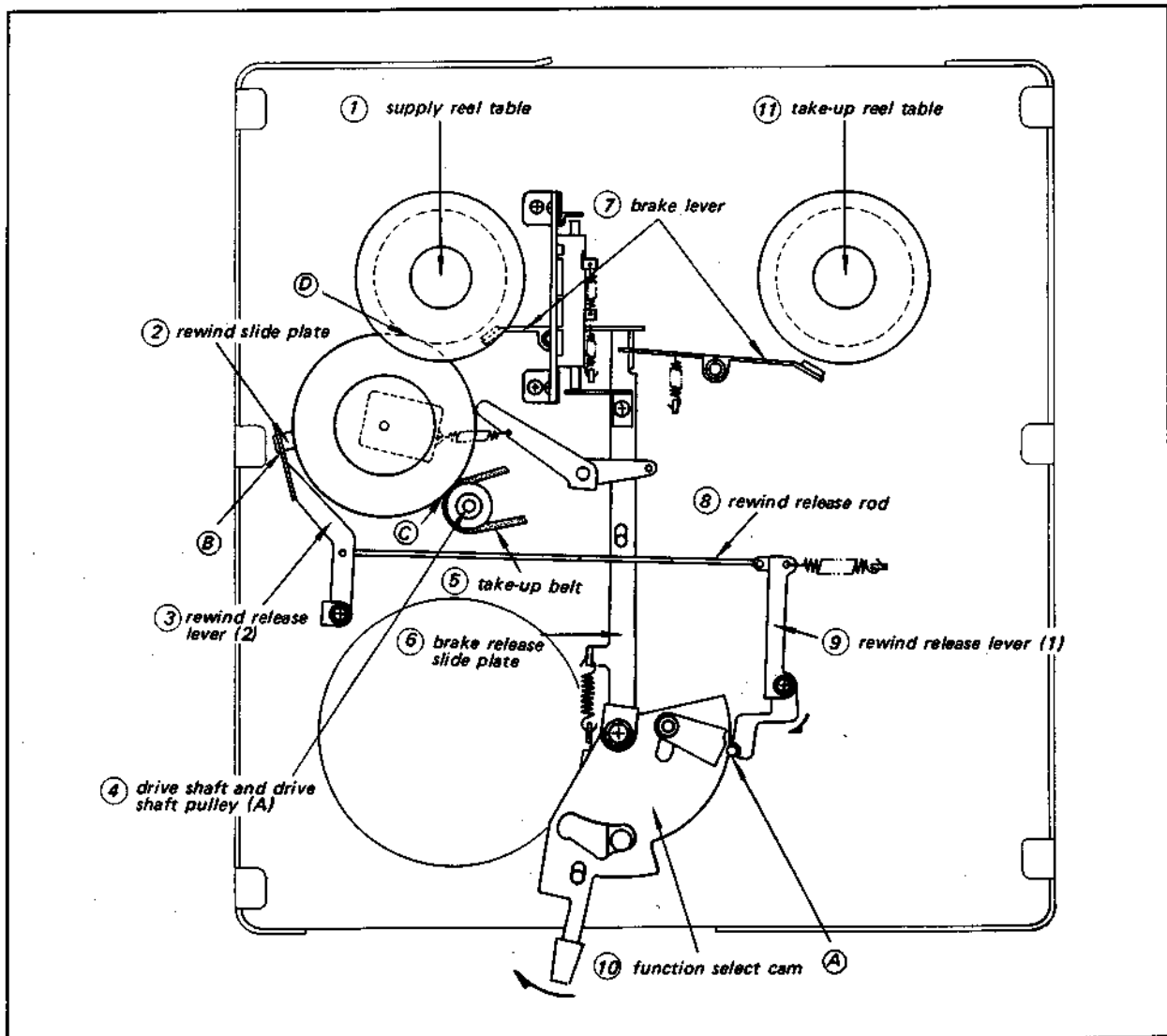

Fig. 9-8 Rewind mode tape transport

SECTION 10 SCHEMATICS AND EXPLODED VIEWS

BLOCK DIAGRAM

PRECAUTIONS

1. Do not attempt complete disassembly of any of the subassemblies. Disassembly should never go beyond that shown in the exploded views. Replacement of the parts without part numbers calls for precision work which should not be attempted in the field.
2. Assemblies with defects in parts other than those shown in the exploded views as replaceable should be replaced by new assemblies.
3. If mechanical damage requires replacement and/or adjustment of the guides in the tape path, return the unit to a SONY FACTORY SERVICE CENTER for repair.

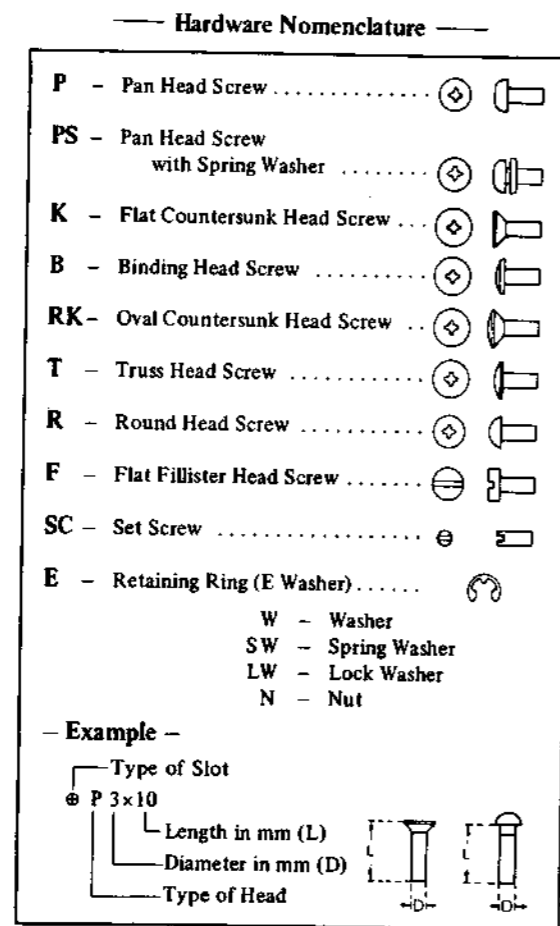

All screws conform to ISO standards, unless otherwise noted

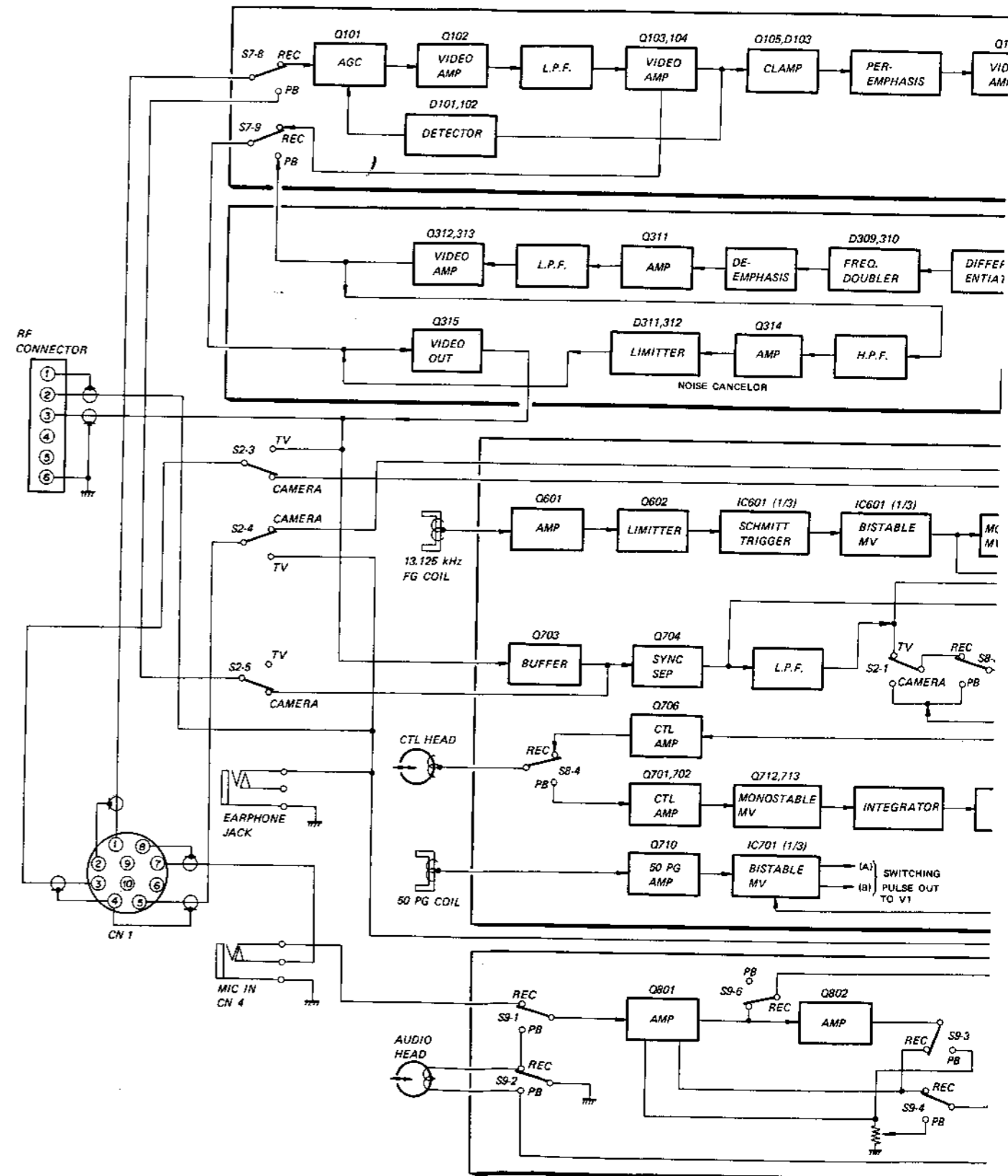
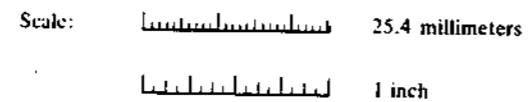

BLOCK DIAGRAM

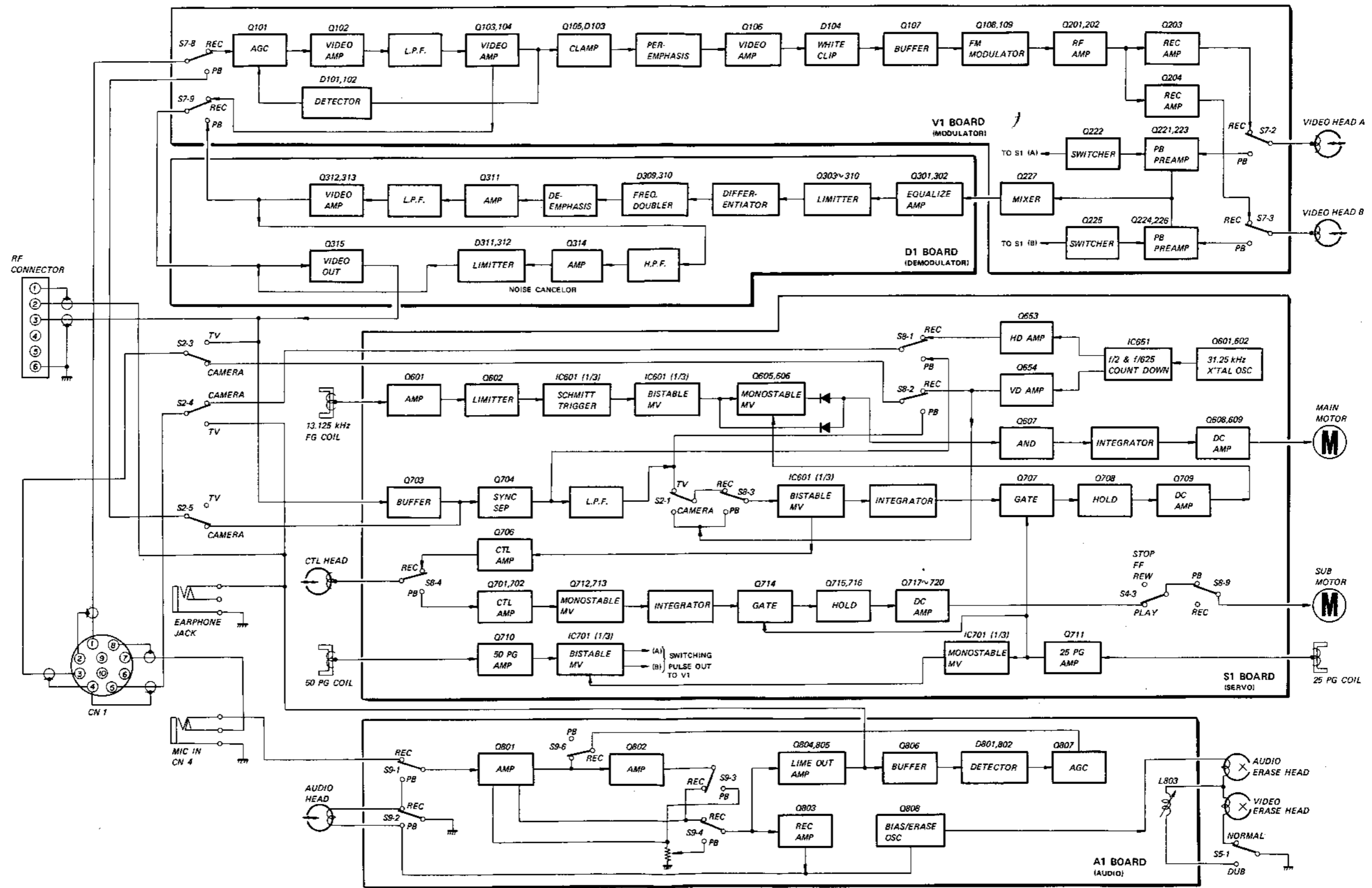

Semiconductor Electrodes

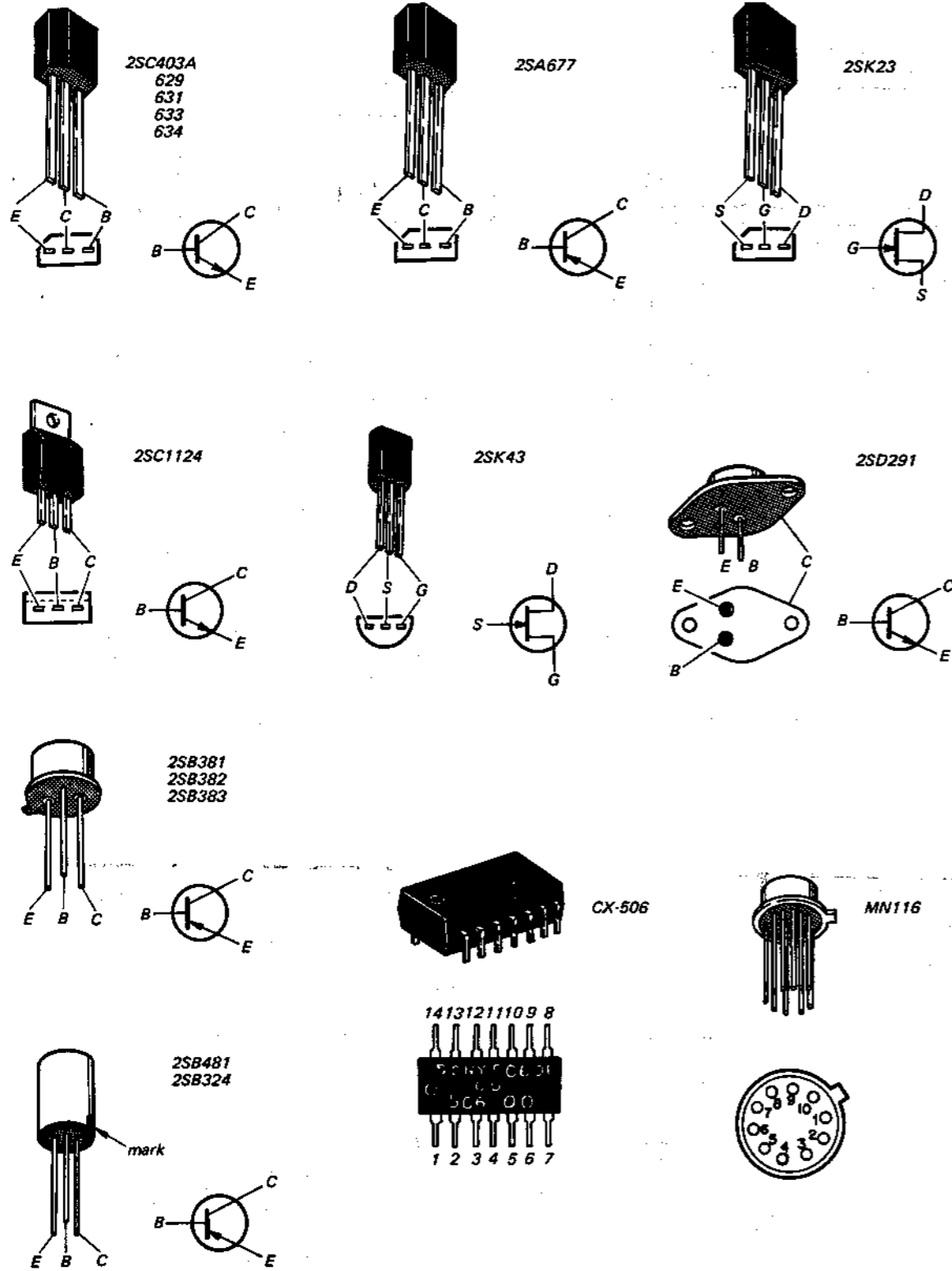

V1 (MODULATOR, REC/PB AMP) PRINTED CIRCUIT BOARD
X-36186-54-1

D1
X-36

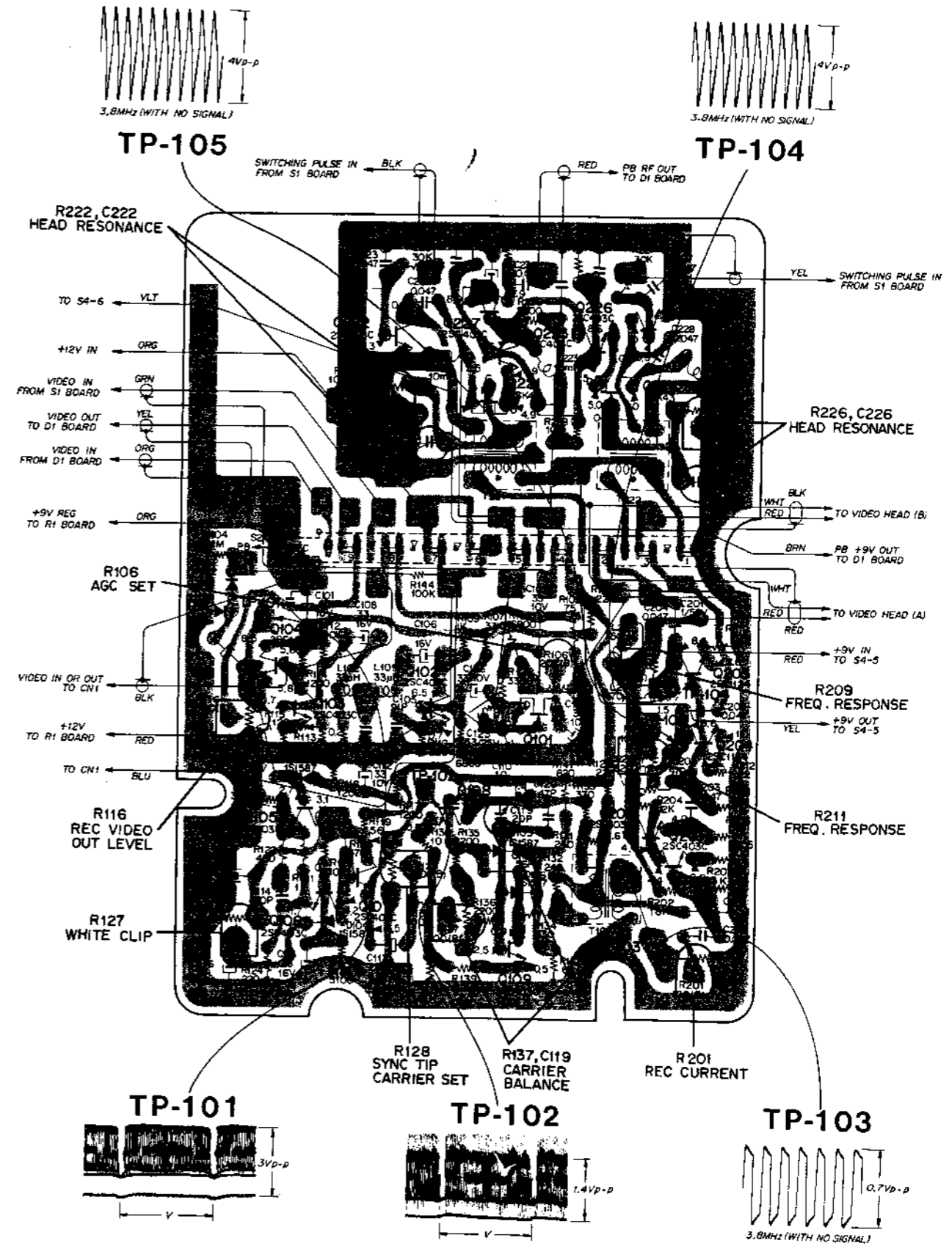

A1 (AUDIO) PRINTED CIRCUIT BOARD
X-36186-51-2

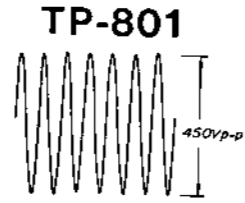
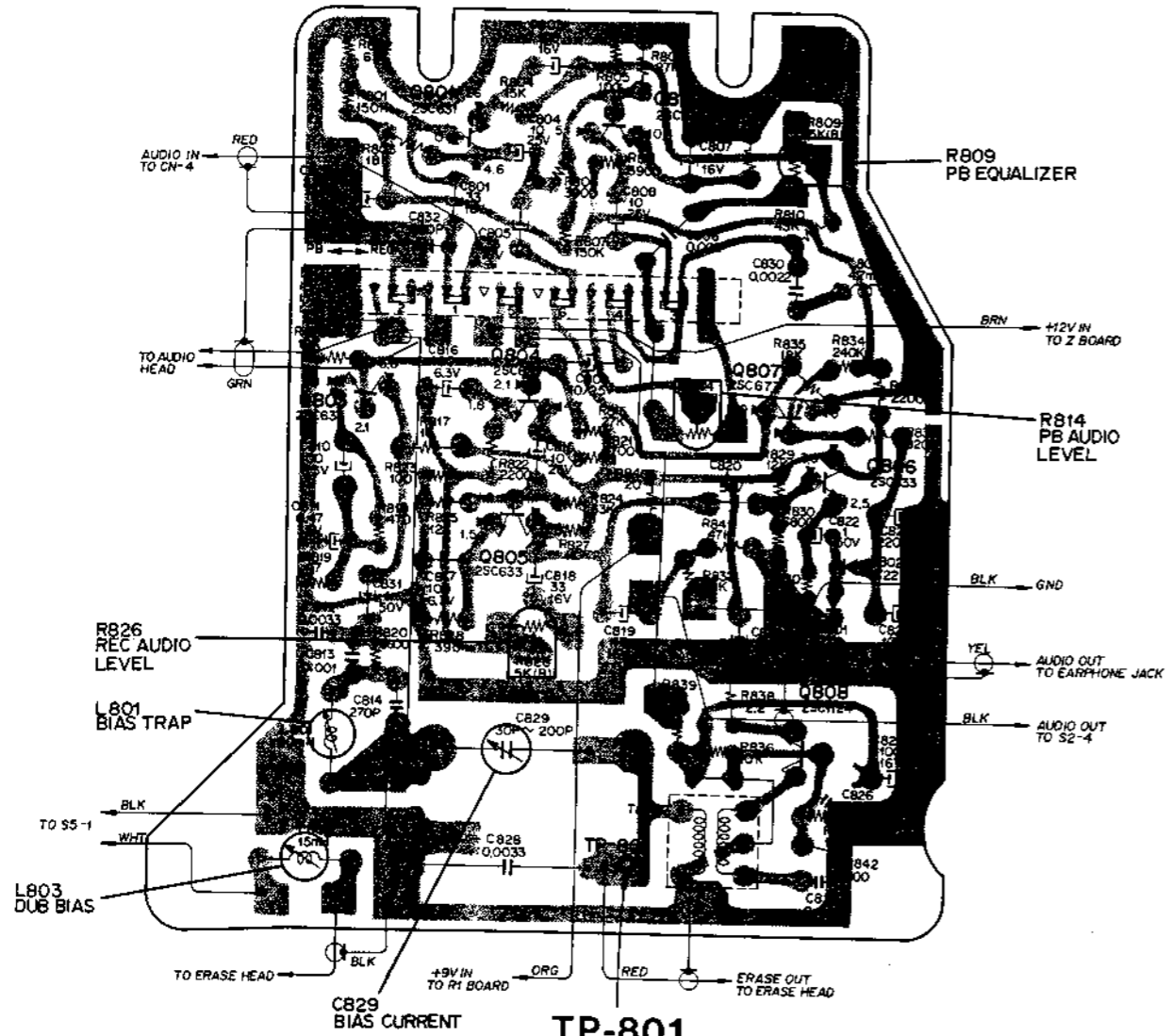

R1 (REGULATOR) PRINTED CIRCUIT BOARD
X-36186-53-1

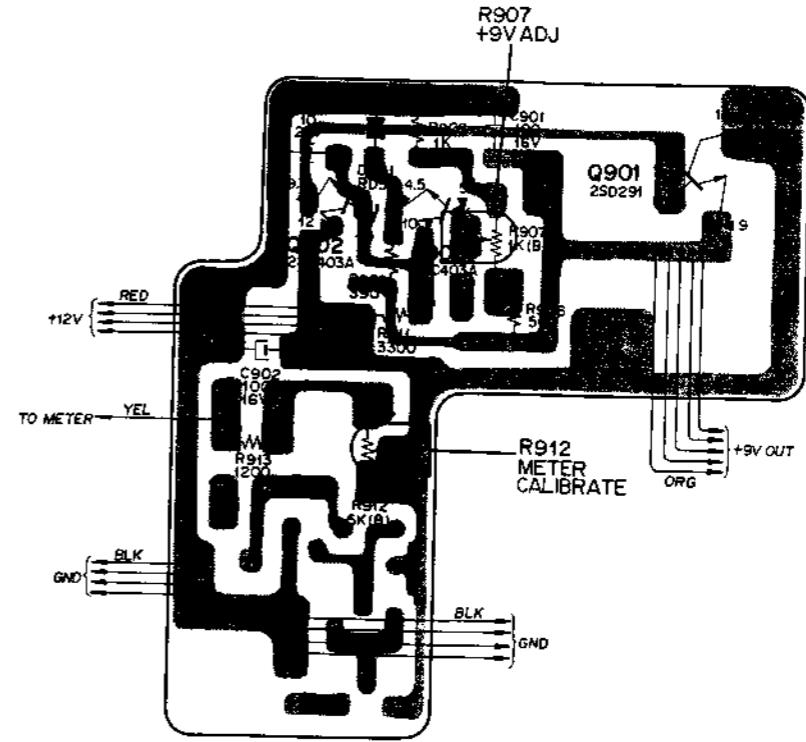

Z PRINTED CIRCUIT BOARD
X-36186-52-1

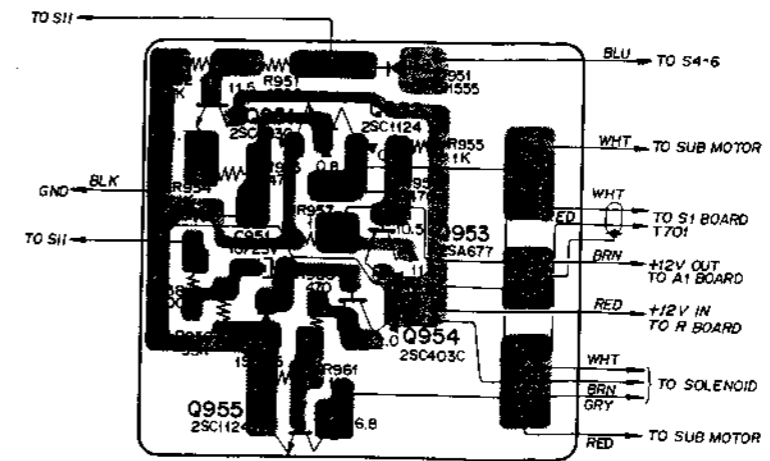

S1 (SERVO) PRINTED CIRCUIT BOARD
X-36186-68-2

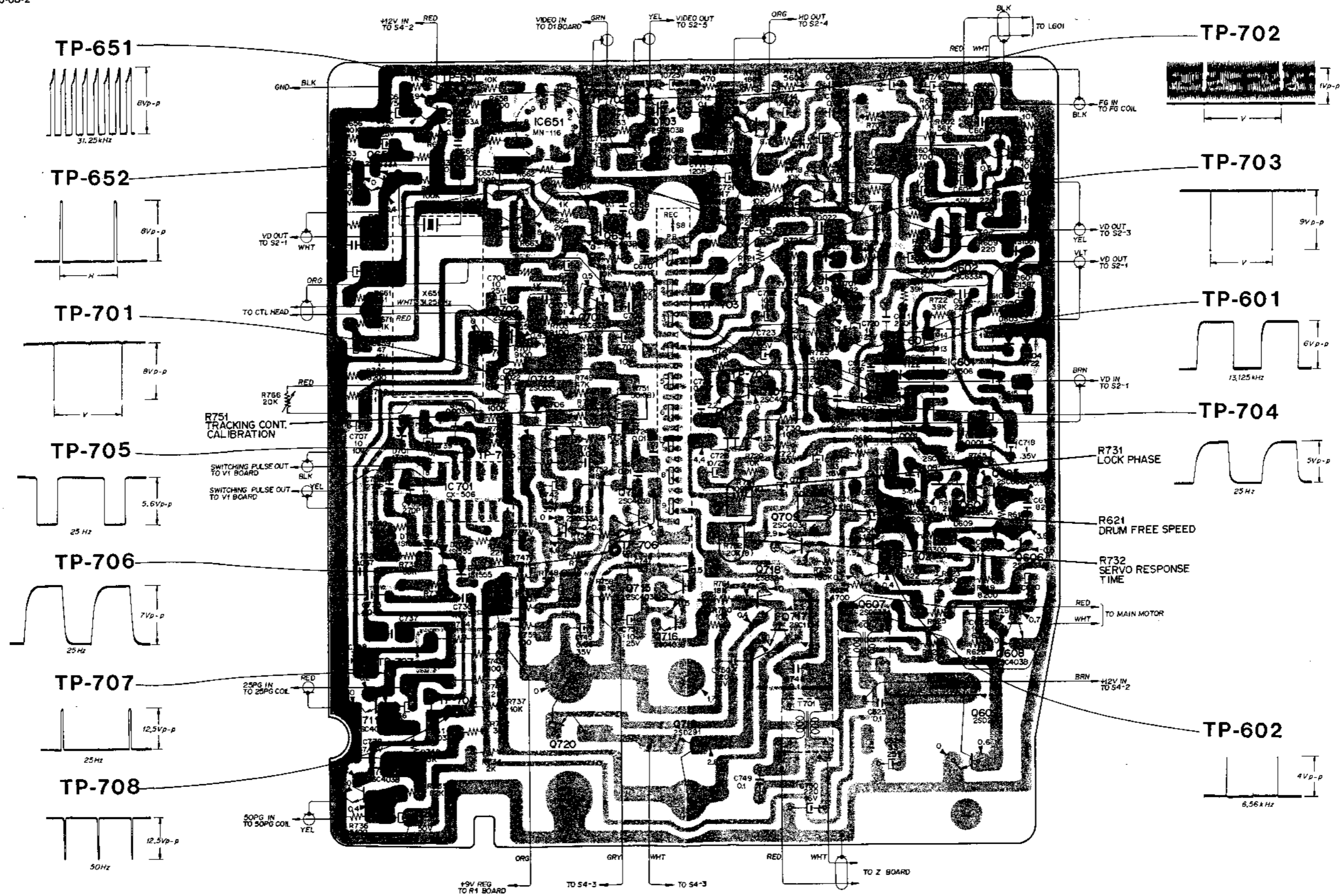

SCHEMATIC DIAGRAM
C-36186-01-2

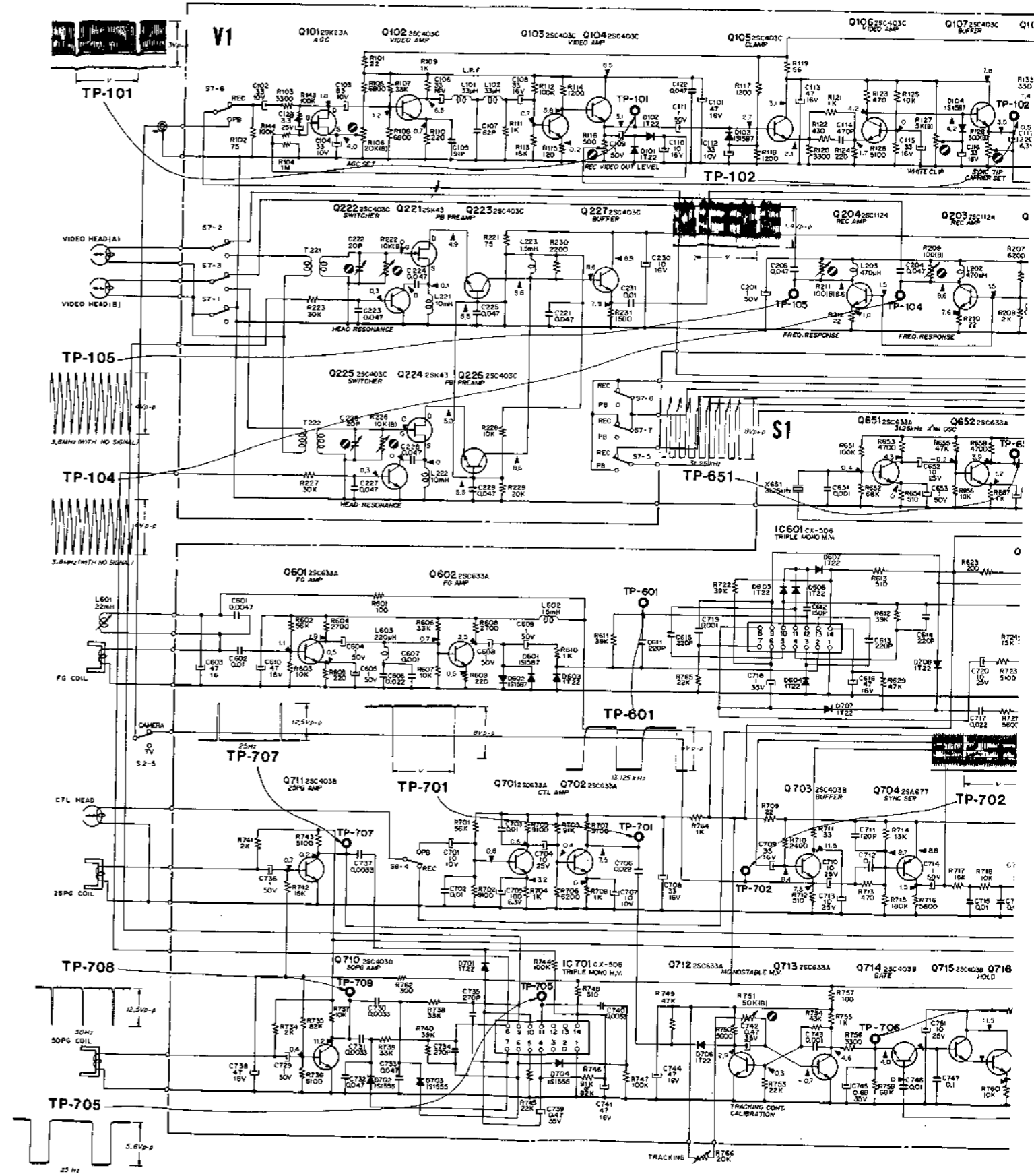

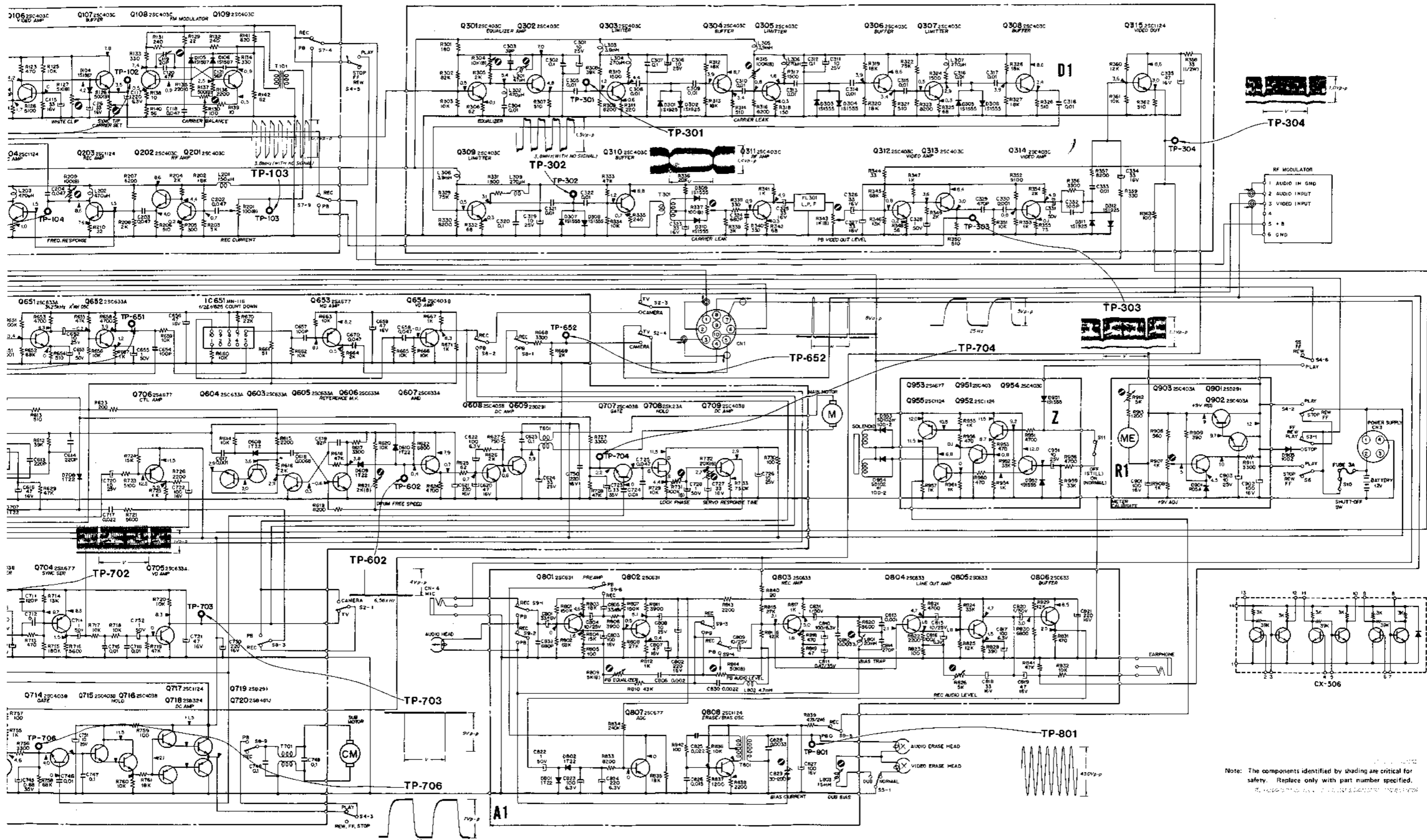

Note: The components identified by shading are critical for safety. Replace only with part number specified.

SCHEMATIC DIAGRAM

C-36186-01-2

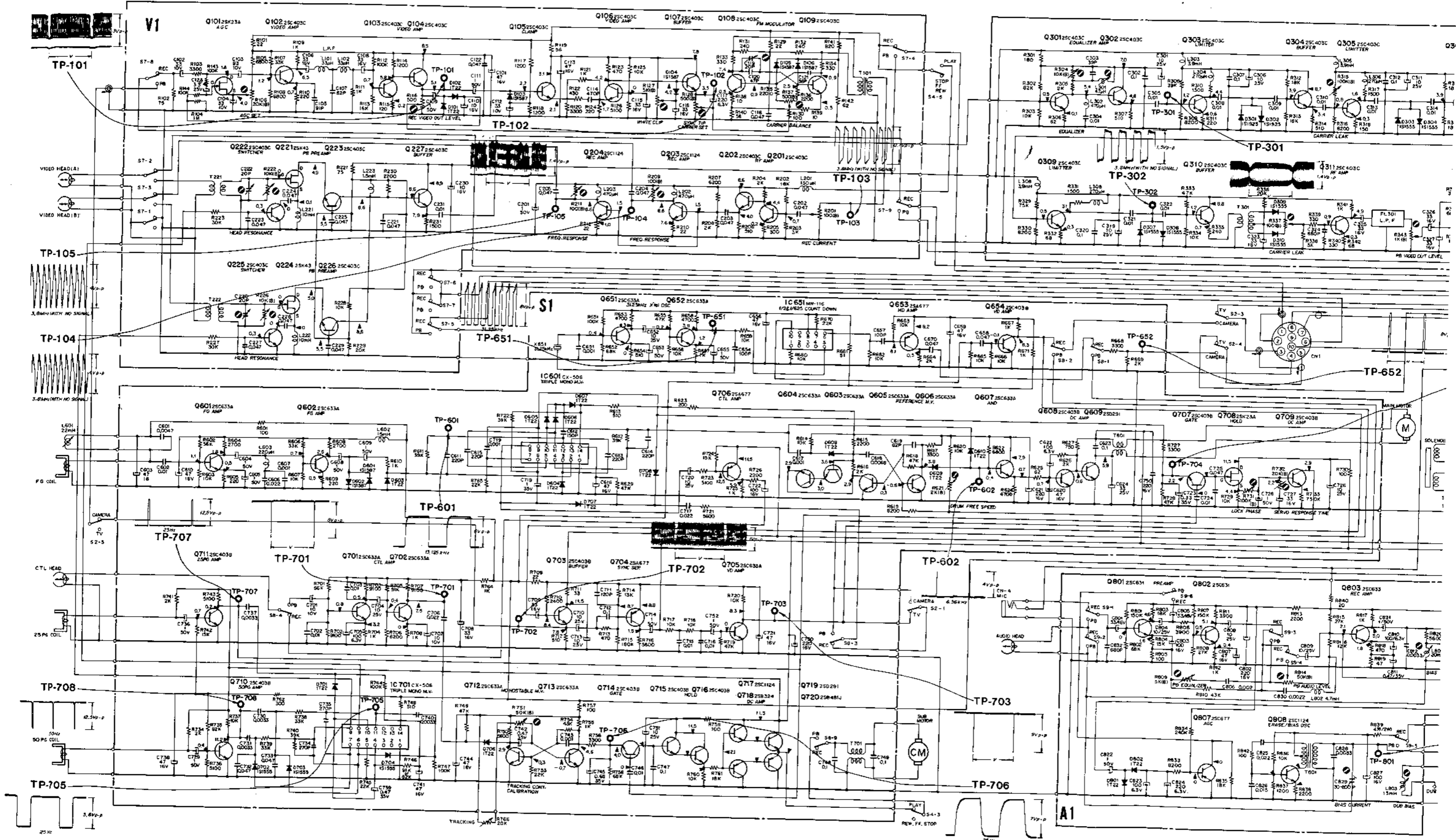

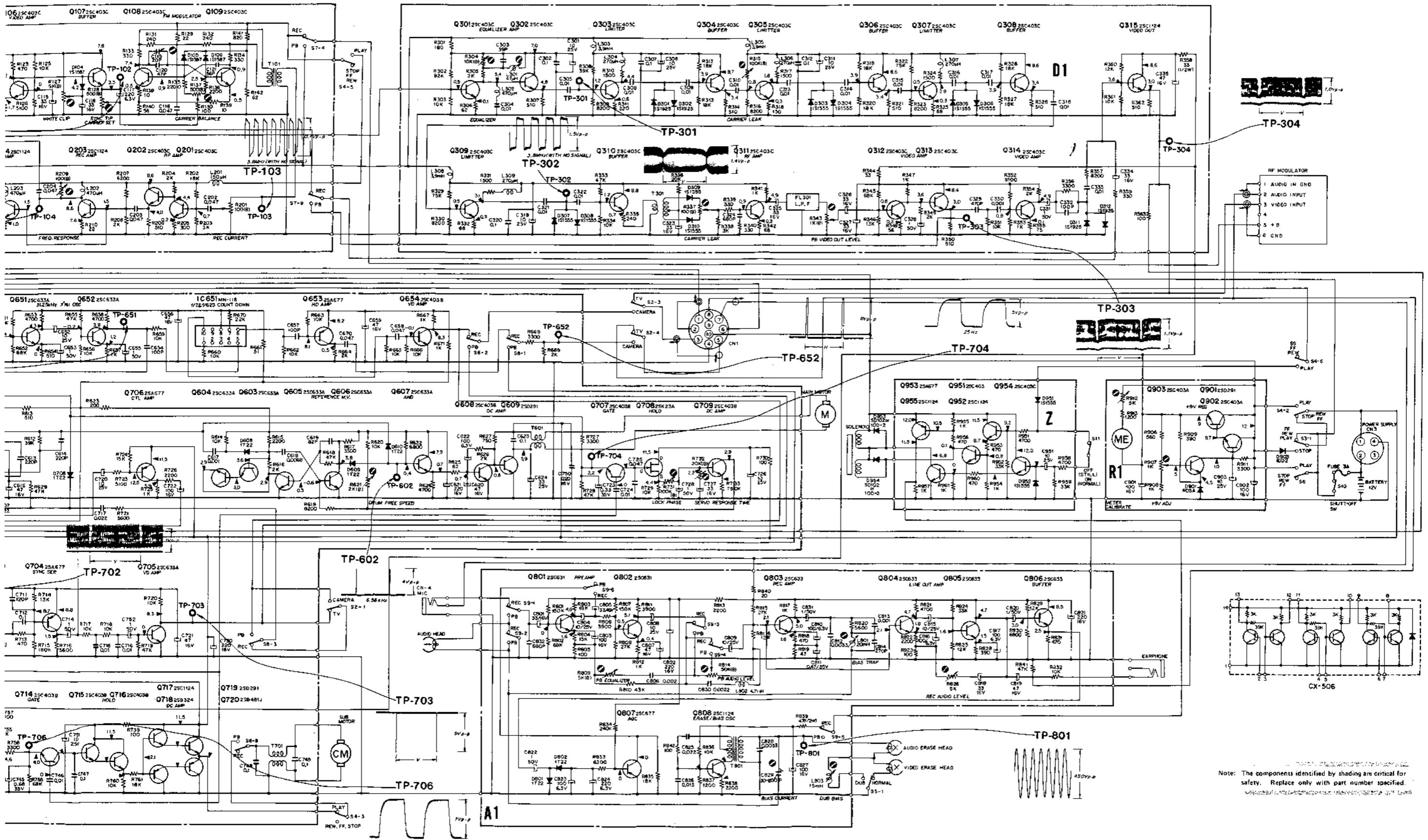

Note: The components identified by shading are critical for safety. Replace only with part number specified.

EXPLODED VIEWS

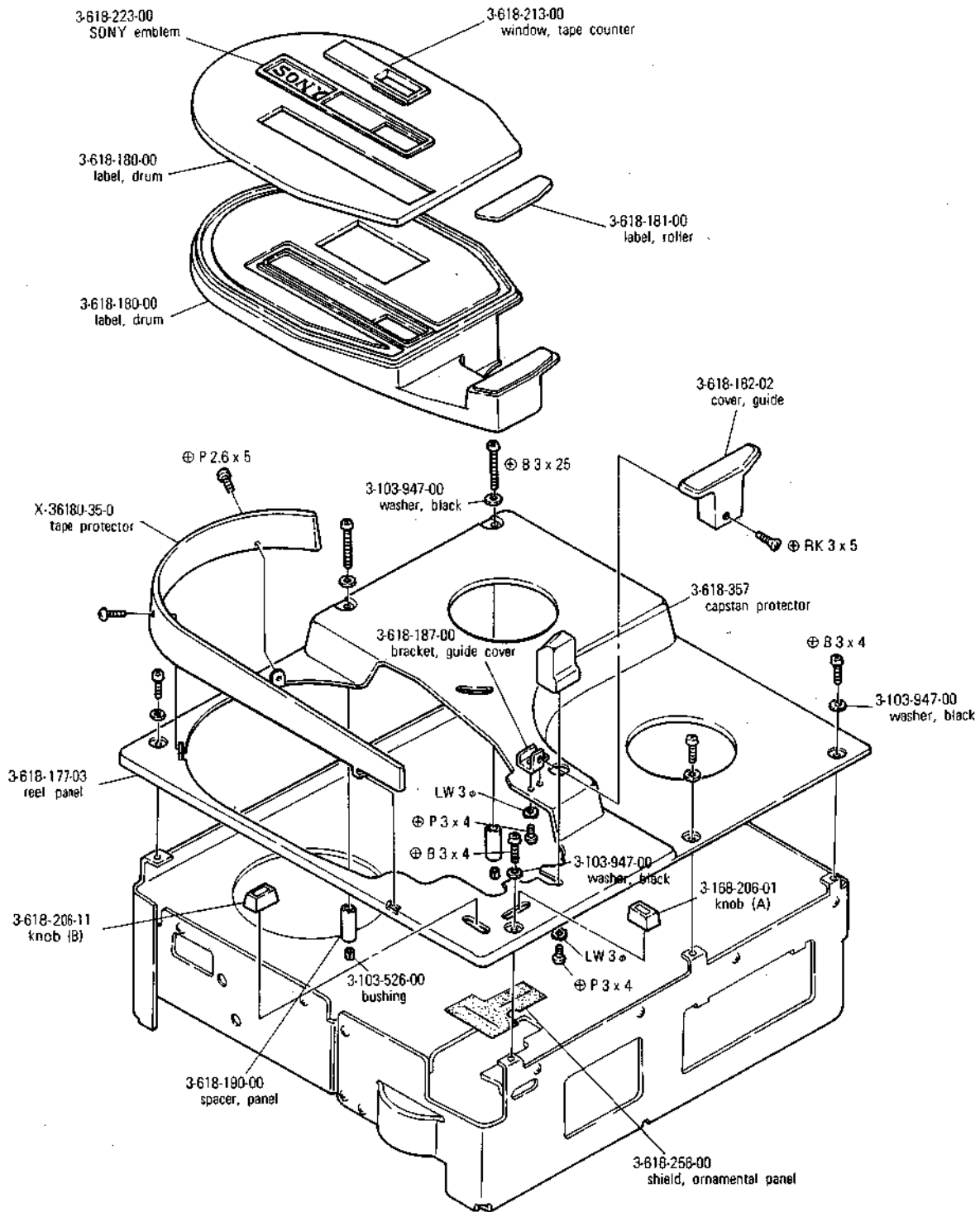

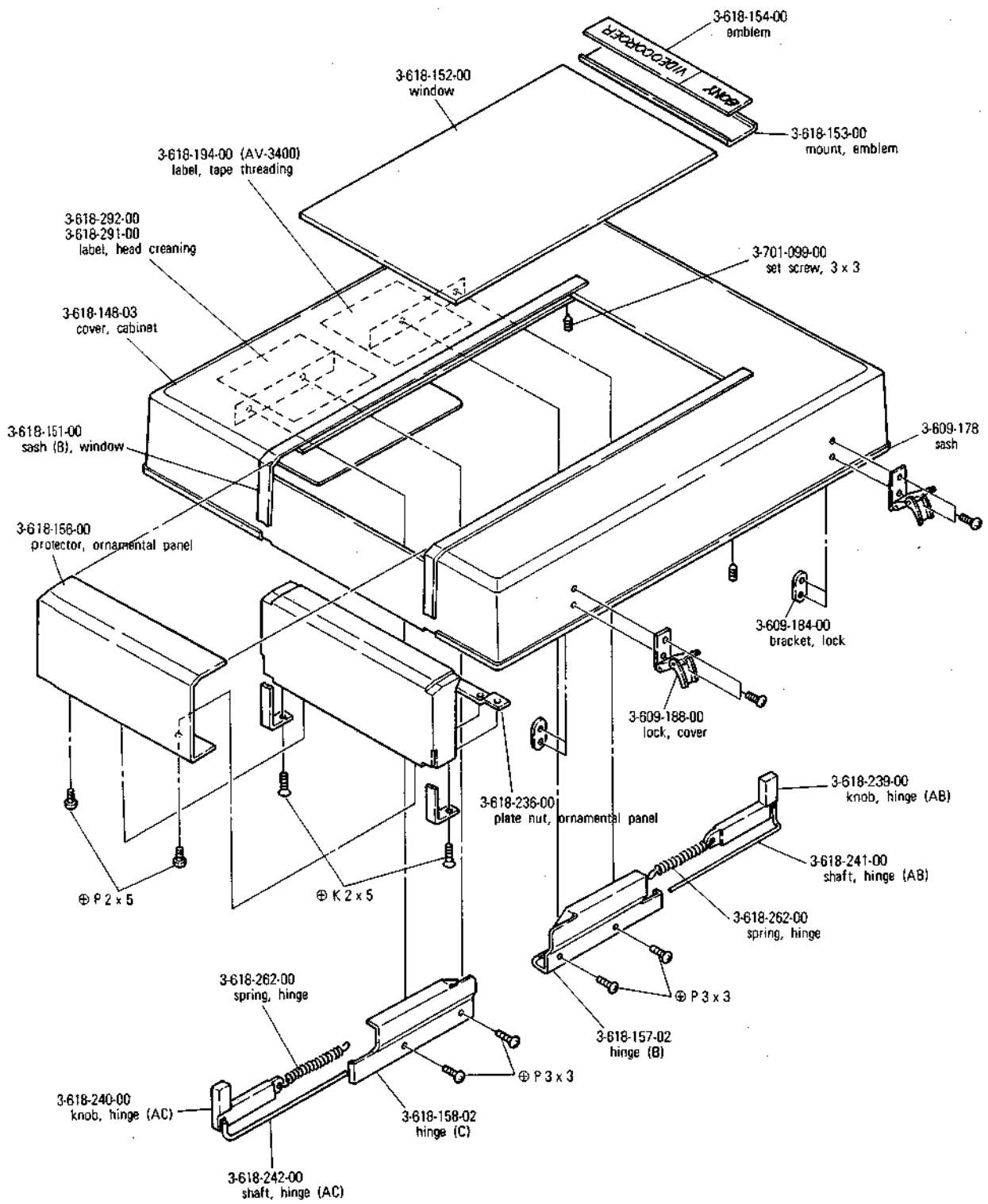

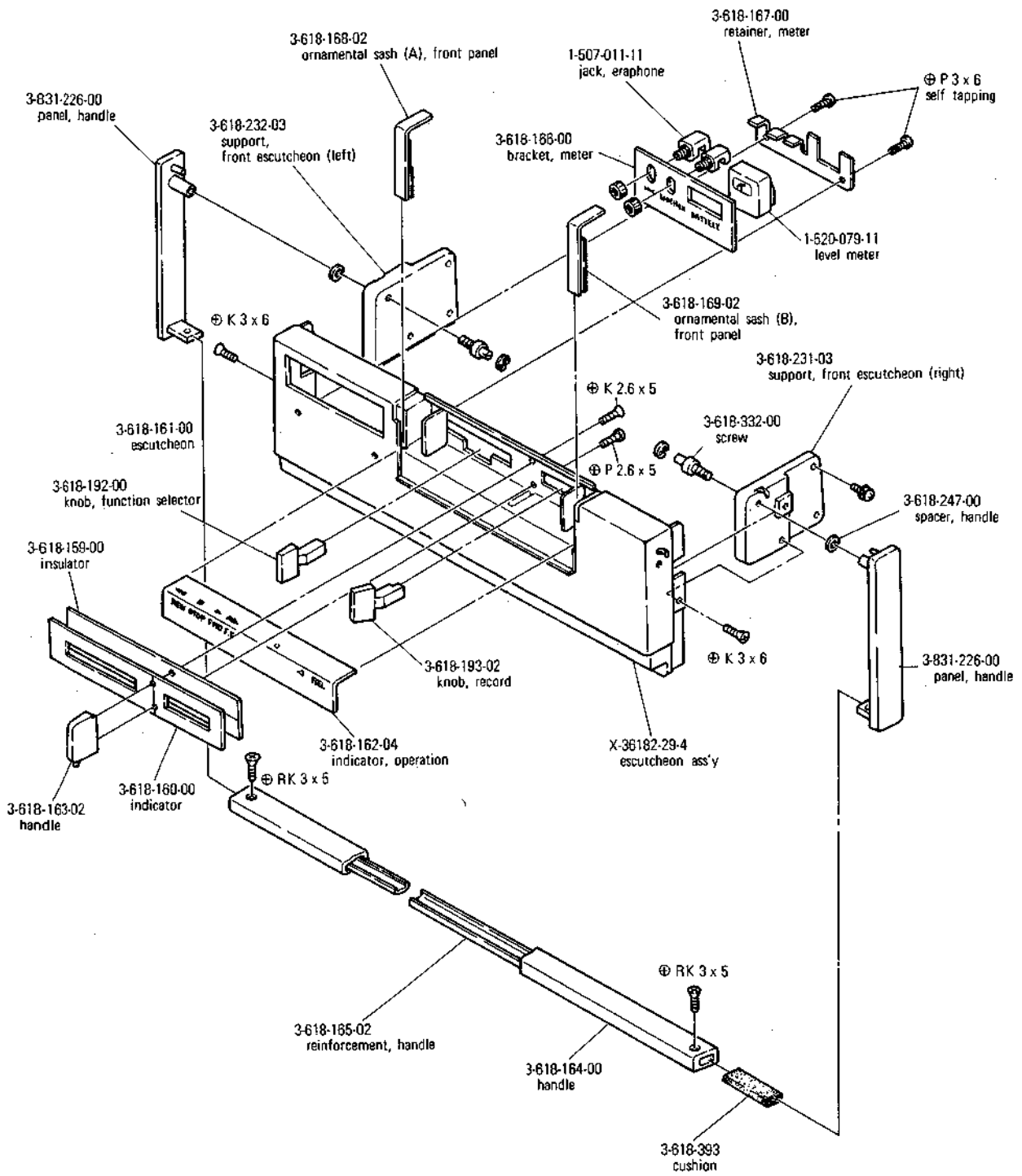

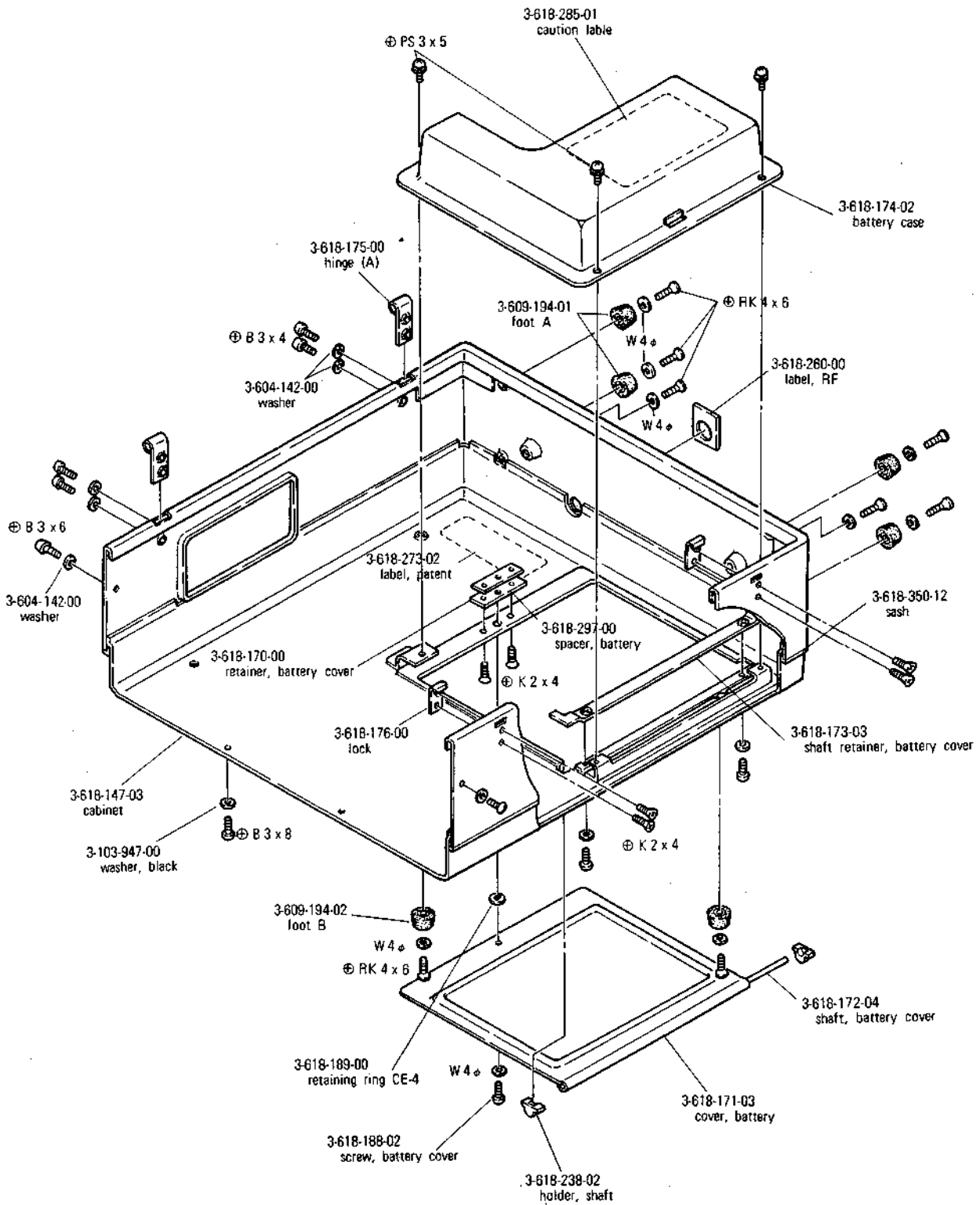

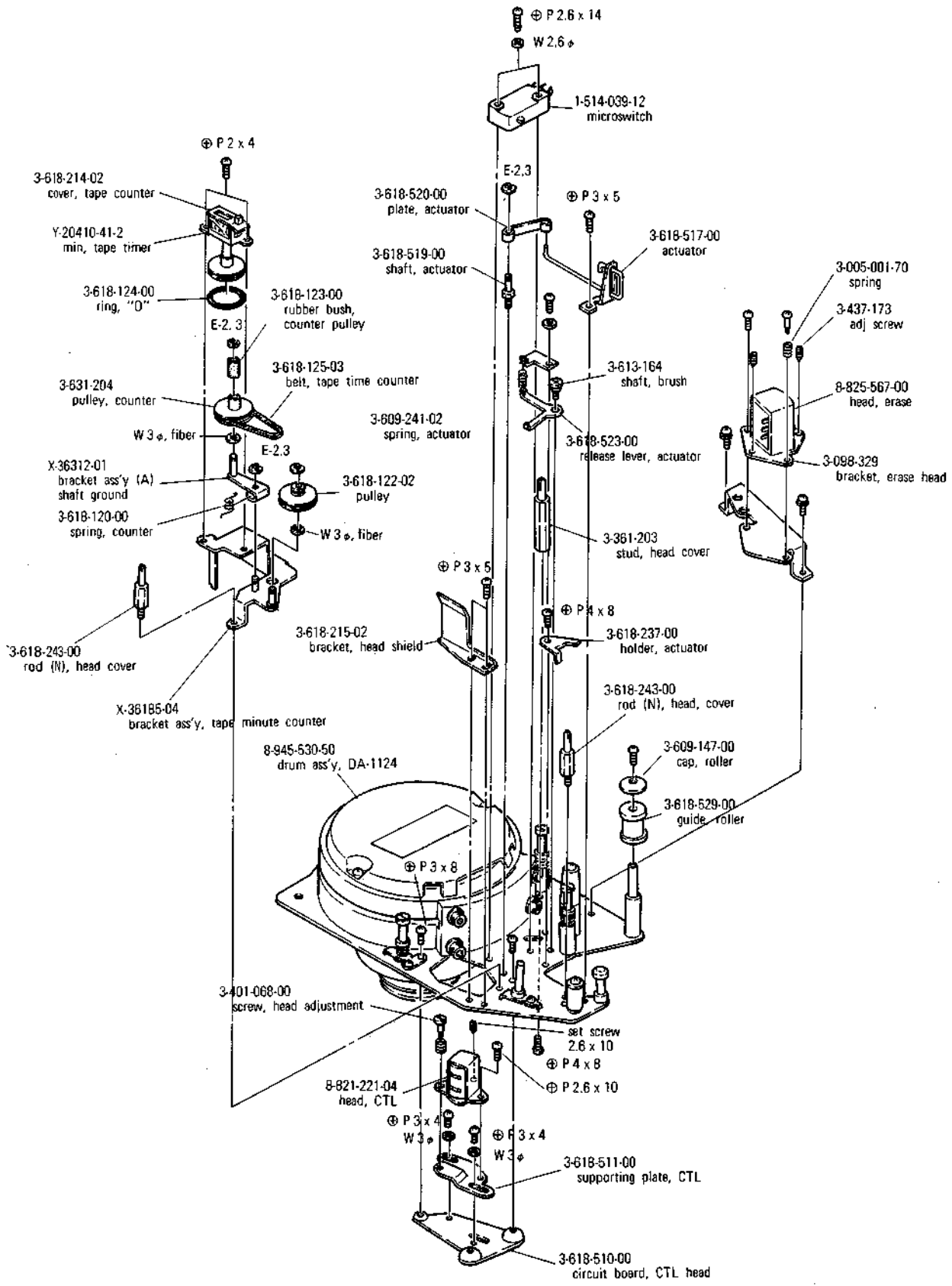

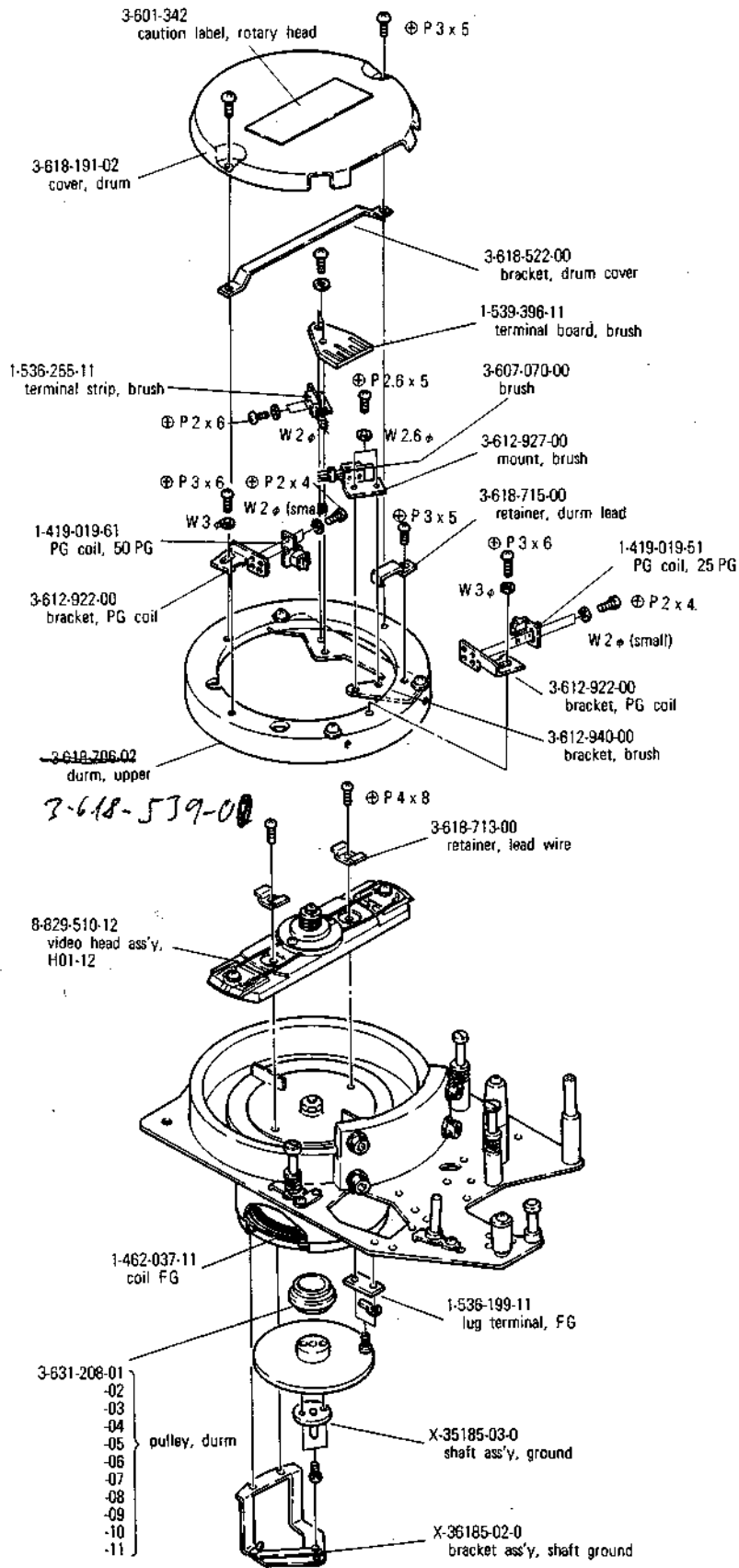

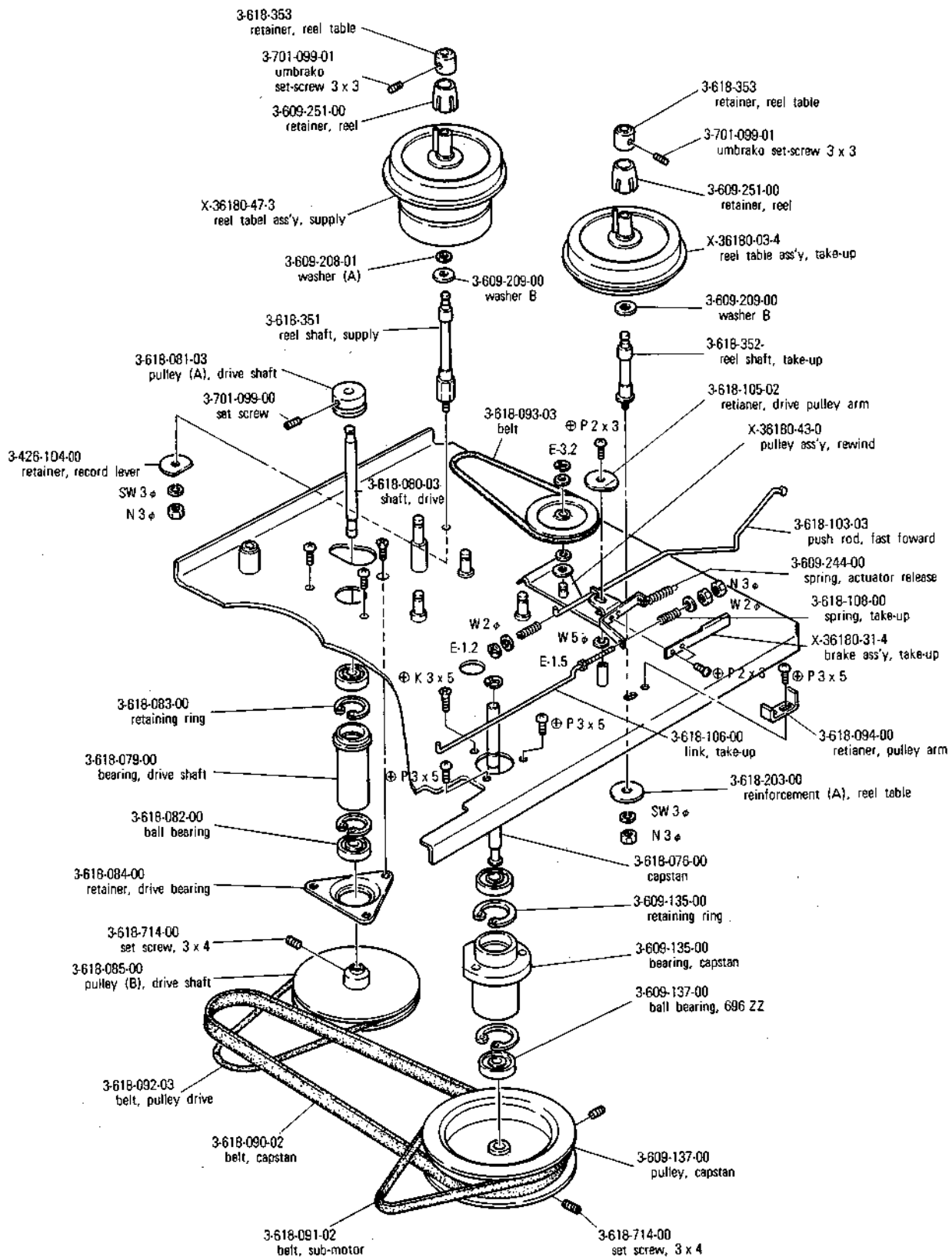

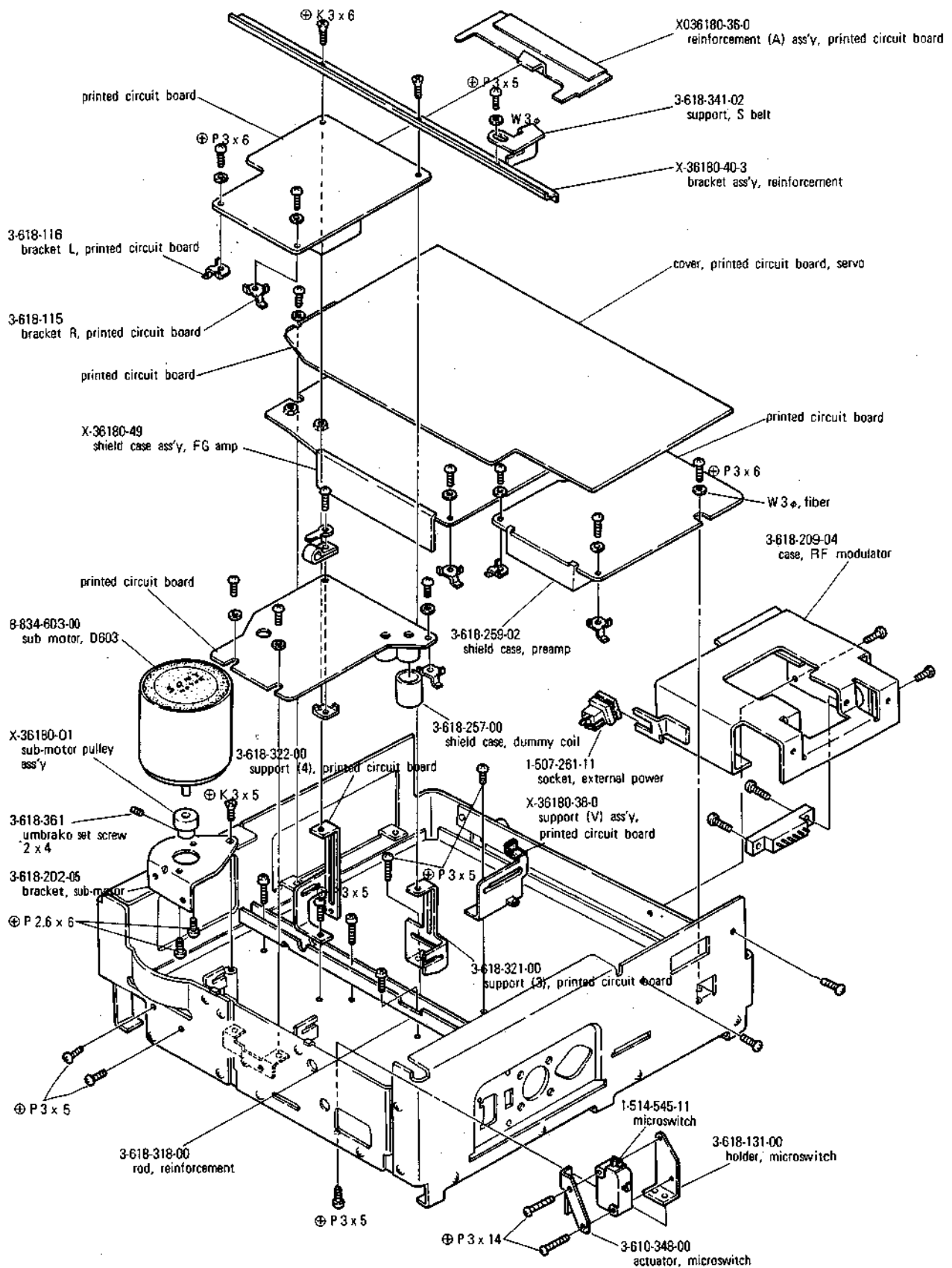

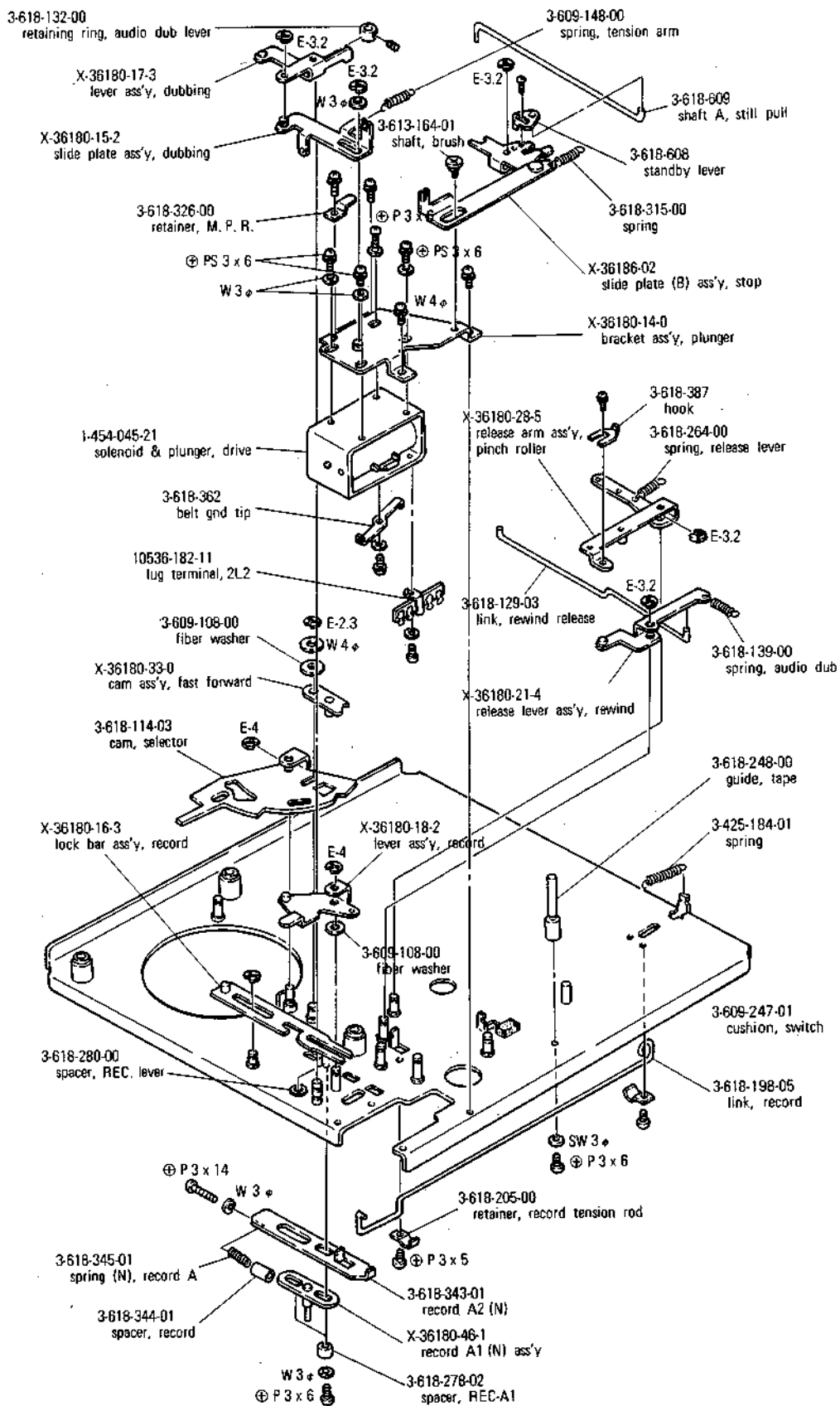

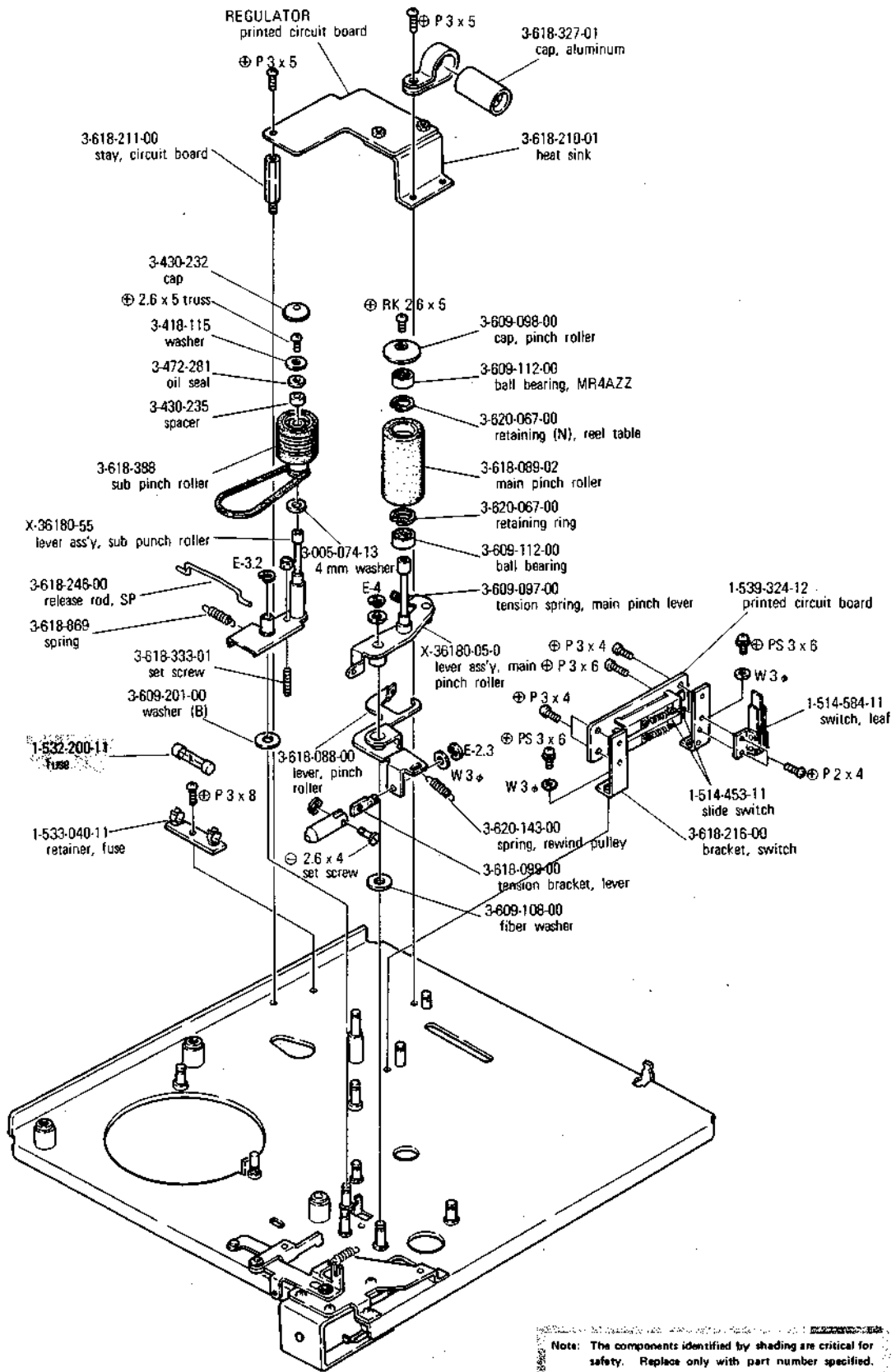

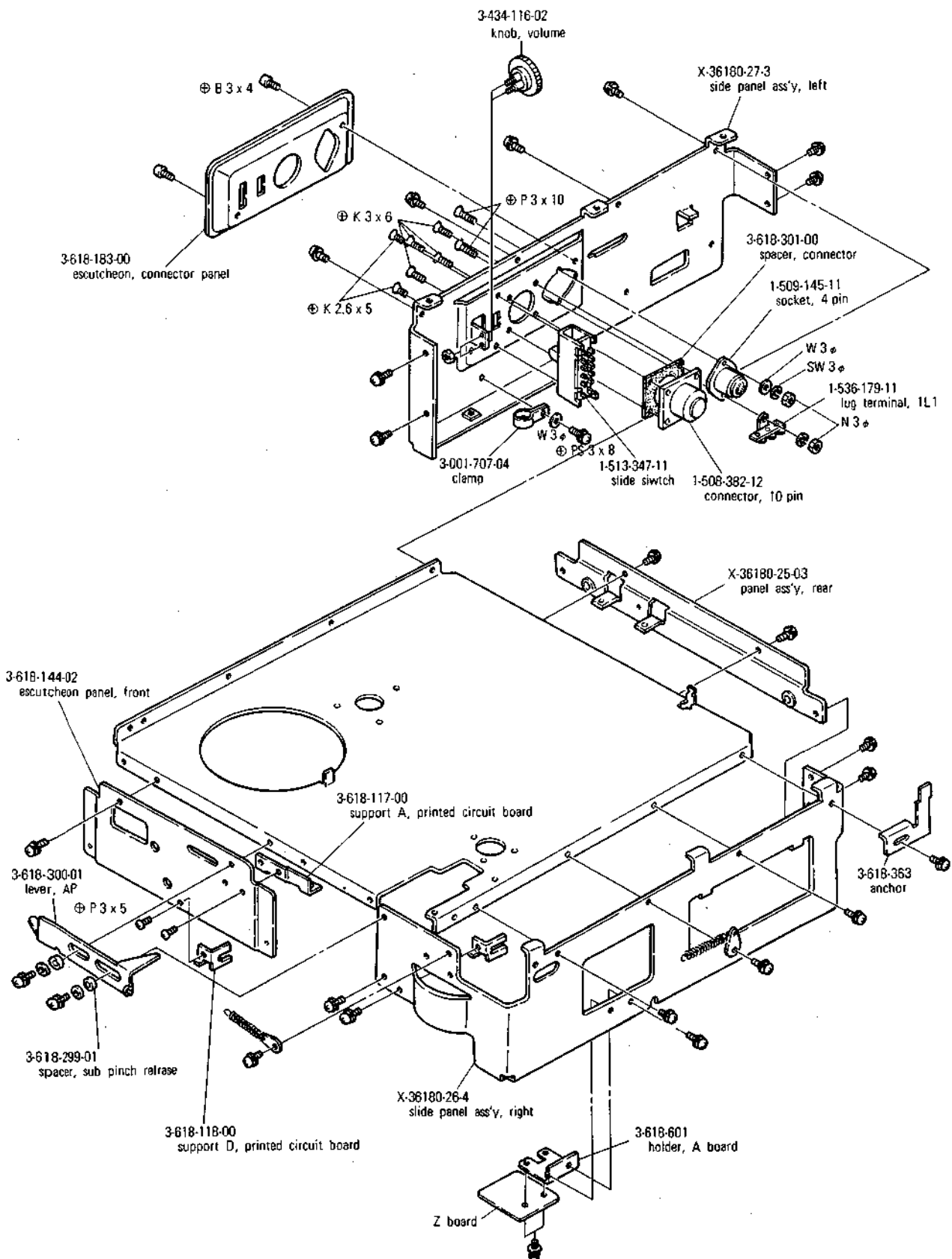

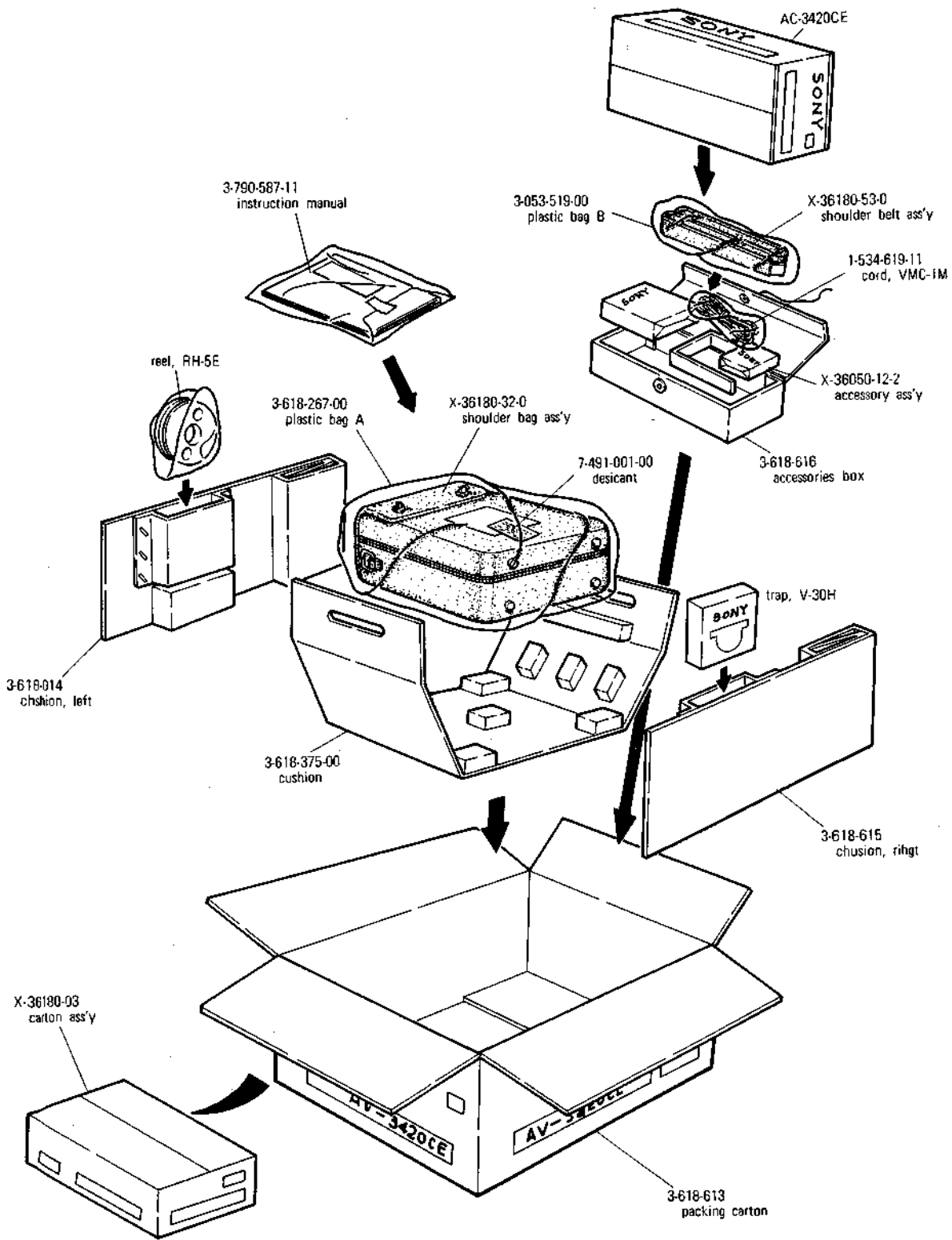

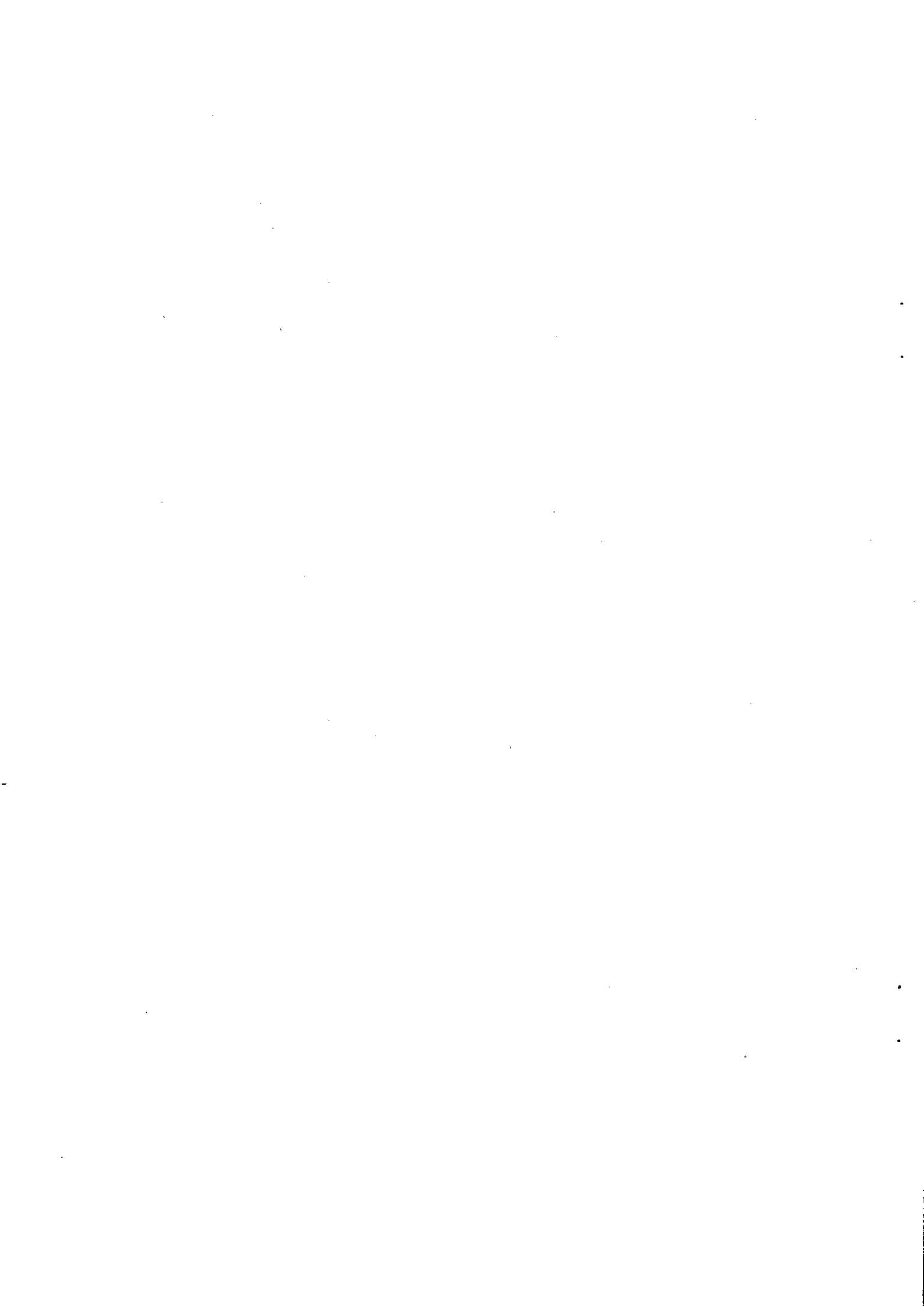

SONY®

Complete Spare Parts List

AV-3420CE

IMPORTANT

When ordering parts, be sure to furnish the following information:

1. Part Number
2. Model Number
3. Description as contained in this parts list

Due to our use of an electronic data processing system, your orders are processed by the PART NUMBER specified by you.

Please order carefully-wrong part numbers result in wrong parts.

NOTE:

Prices are subject to change without notice.

April, 1973

MECHANICAL PARTS LIST

<u>Part No.</u>	<u>Description</u>	<u>Part No.</u>	<u>Description</u>
X-00270-03-2	Idler Ass'y A	X-36185-04	Bracket Ass'y, tape minute counter
X-36050-12-3	Accessory Ass'y, including	X-36186-02	Slide Plate (A) Ass'y, stop
X-36010-48	Splicing Tape Ass'y	X-36186-03	Carton Ass'y
X-36070-23	Head Cleaner Ass'y	3-618-375	Cushion
X-44900-02	Polishing Cloth Ass'y	3-618-613	Packing Carton
X-20310-01	Cleaning Fluid Ass'y	3-618-614	Cushion (Left)
3-605-028	Accessory Bag	3-618-615	Cushion (Right)
X-36180-01	Sub-motor Pulley Ass'y (CE)	3-618-616	Accessory Box
X-36180-03-4	Reel Table Ass'y, take-up Retaining Ring	X-36312-01	Lever Ass'y, pulley
		Y-20410-41-2	Mini Tape Timer
X-36180-05	Lever A Ass'y, main pinch-roller	0-027-216	Oil Ring, 5 mm dia
X-36180-08-4	Lever Ass'y, brake	0-051-040	Spring, head
X-36180-09-3	Link Lever (S) Ass'y, REC	1-504-021-11	Earphone
X-36180-10-3	Link Lever (V) Ass'y, reocrd	1-534-619-11	Cord, VMC-1M
X-36180-14	Bracket Ass'y, plunger	2-053-519	Plastic Bag B
X-36180-15-2	Slide Plate Ass'y, dubbing	2-825-005	Spacer, MD-17
X-36180-16-3	Lock Bar Ass'y, reocrd	3-001-707-01	Clamp
X-36180-17-3	Lever Ass'y, dubbing	3-001-707-04	Clamp
X-36180-18-2	Lever Ass'y, record	3-001-707-07	Clamp
X-36180-19-2	Release Lever Ass'y, actuator	3-001-707-09	Clamp
X-36180-21-4	Release Lever Ass'y, rewind	3-005-001-70	Spring
X-36180-24-2	Slide Plate Ass'y, brake release	3-005-074-13	4 mm Washer
X-36180-25-3	Panel Ass'y, rear	3-098-329	Bracket, erase head
X-36180-26-4	Side Panel Ass'y, right	3-103-526	Bush
X-36180-27-3	Side Panel Ass'y, left	3-103-947	Washer, black
X-36180-28-5	Release Arm Ass'y, pinch-roller	3-401-068	Screw, head adjustment
X-36180-29-4	Escutcheon Ass'y	3-418-115-00	Washer
X-36180-31-4	Brake Ass'y, take-up	3-419-098-11	Washer, nylon
X-36180-32	Shoulder Bag Ass'y	3-419-211-03	Cap, idler
X-36180-53	Shoulder Belt Ass'y	3-425-184	Spring
3-618-364	Shoulder Bag	3-426-104-02	Retainer, record lever
X-36180-33	Cam Ass'y (A), fast forward	3-430-232	Cap
X-36180-35	Tape Protector	3-430-235	Spacer
X-36180-36	Reinforcement (A) Ass'y, prtined circuit board	3-434-116-02	Knob, control
		3-434-139	Spring
X-36180-38	Support (V) Ass'y, printed circuit board	3-437-173	Adjusting Screw
X-36180-39-2	Lever (T) Ass'y, brake	3-472-281	Oil Sela
X-36180-40-3	Bracket Ass'y, reinforcement	3-509-140	Fastner
X-36180-43	Pulley Ass'y, rewind including	3-601-107	Spring
		3-601-127	Holder
3-618-233-04	Pulley, rewind	3-601-342	Caution Label, rotary head
X-36180-44	Arm Ass'y, rewind pulley	3-601-345	Check Lug
X-36180-45	Reinforcement Ass'y, deck, including	3-604-142	Washer
3-618-318-00	Rod, reinforcement	3-604-169	Holder (2), spring
		3-607-738	Spring, tape guide
X-36180-46	Record A1 (N) Ass'y	3-607-745	Spring, tension arm
X-36180-47	Reel Table Ass'y, supply	3-609-097	Tension Spring, main pinch lever
X-36180-48	Reel Tble Ass'y, (N), supply	3-609-098	Cap, pinch roller
X-36180-49	FG Amp Shield Case Ass'y	3-609-108	Fiber Washer
X-36180-55	Lever Ass'y, sub-pinch roller	3-609-112	Ball Bearing, MR 4AZZ
X-36180-56	Tension Arm Ass'y	3-609-135	Retaining Ring
X-36180-57	Band Ass'y, tension regulator	3-609-137	Ball Bearing, 696 ZZ
X-36180-58	Stud Ass'y	3-609-140	Spacer, reel table
X-36185-02	Bracket Ass'y, shaft ground	3-609-147	Cap, roller
X-36185-03	Shaft Ass'y, ground	3-609-148-02	Spring, tension arm

<u>Part No.</u>	<u>Description</u>	<u>Part No.</u>	<u>Description</u>
3-609-178	Sash	3-618-136-04	Slide Bracket for Rewind, lower
3-609-184	Bracket, lock	3-618-138	Spacer (2), rewind
3-609-188	Lock, cover	3-618-139	Spring, audio dub
3-609-194-01	Foot A		Spring, rewind lever (1)
3-609-194-02	Foot B	3-618-144-02	Escutcheon Panel, front
3-609-208	Washer (A)	3-618-147-03	Cabinet
3-609-209	Washer (B)	3-618-148-03	Cover, cabinet
3-609-244-02	Spring, actuator release	3-618-150	Sash (A), window
3-609-247	Cushion, switch	3-618-151	Sash (B), window
3-609-251	Retainer, reel	3-618-152	Window
3-610-348	Actuator, microswitch	3-618-153	Mount, emblem
3-613-164	Shaft, brush	3-618-154	Emblem
3-618-075	Bearing, capstan	3-618-155-03	Ornamental Panel, cover
3-618-076	Capstan	3-618-156	Protector, ornamental panel
3-618-077	Pulley, capstan	3-618-157-02	Hinge (B)
3-618-078	Retaining Ring, CE-6	3-618-158-02	Hinge (C)
3-618-079	Bearing, drive shaft	3-618-159	Insulator
3-618-080-03	Shaft, drive shaft	3-618-160	Indicator
3-618-081-03	Pulley (A), drive shaft	3-618-161	Escutcheon
3-618-082	Ball Bearing	3-618-162-04	Indicator, operation
3-618-083	Retaining Ring, 0-13	3-618-163-02	Handle
3-618-084	Retainer, drive bearing	3-618-164	Handle
3-618-085	Pulley (B), drive shaft	3-618-165-02	Reinforcement, handle
3-618-088	Lever, pinch roller	3-618-166	Bracket, meter
3-618-089-02	Main Pinch Roller	3-618-167	Retainer, meter
3-618-090-02	Belt, capstan	3-618-168-02	Ornamental Sash (A), front panel
3-618-091-02	Belt, sub-motor	3-618-169-02	Ornamental Sash (B), front panel
3-618-092-03	Belt, pulley drive	3-618-170	Retainer, battery cover
3-618-093-03	Belt, take-up drive	3-618-171-03	Cover, battery
3-618-094	Retainer, pulley arm	3-618-172-04	Shaft, battery cover
3-618-099	Tension Bracket, lever	3-618-173-03	Shaft Retainer, battery cover
3-618-103-03	Push Rod, fast forward	3-618-174-03	Battery Case
3-618-105-02	Retainer, drive pulley arm	3-618-175	Hinge (A)
3-618-106	Link, take-up	3-618-176	Lock
3-618-107	Spring, fast forward	3-618-177-11	Reel Panel (CE)
3-618-108	Spring, take-up	3-618-179	Cover, head
3-618-109-03	Sub Pinch Roller	3-618-180	Lable, drum
3-618-114-03	Cam, selector	3-618-181	Lable, roller
3-618-115	Bracket R, printed circuit board	3-618-182-02	Cover, guide
3-618-116	Bracket L, printed circuit board	3-618-183	Label, connector panel
3-618-117	Support A, printed circuit board	3-618-186	Actuator, shut-off switch
3-618-118	Support D, printed circuit board	3-618-187	Bracket, guide cover
3-618-120	Spring, counter	3-618-188-02	Screw, battery cover
3-618-122	Pulley	3-618-189	Retaining Ring, CE-4
3-618-123	Rubber Bush, counter pulley	3-618-190	Spacer, panel
3-618-124	Ring, O	3-618-191	Cover, drum
3-618-124-02	Cover, tape counter	3-618-192	Knob, function selector
3-618-125-03	Belt, tape counter	3-618-193-02	Knob, record
3-618-128-03	Lever (2), rewind release	3-618-194	Label, tape threading
3-618-129-03	Link, rewind release	3-618-198-05	Link, record
3-618-131-03	Holder, microswitch	3-618-199	Nameplate
3-618-132	Retaining Ring, audio dub lever	3-618-202-05	Bracket, sub-motor
3-618-133-02	Slide Bracket, rewind upper	3-618-203	Reinforcement (A), reel table
3-618-135-03	Shaft, rewind	3-618-205	Retainer, record tension rod
		3-618-206-01	Knob (A)

<u>Part No.</u>	<u>Description</u>	<u>Part No.</u>	<u>Description</u>
3-618-206-11	Knob (B)	3-618-326	Retainer, M. P. R.
3-618-209-04	Case, RF modulator	3-618-327	Cap, aluminum
3-618-210	Heat Sink	3-618-328	Cover, prevent1
3-618-211	Stay, circuit board	3-618-332	Screw
3-618-213	Window, tape counter	3-618-333	Set Screw
3-618-214-03	counter cover	3-618-340	Connect Rod, reocrd
3-618-215-02	Bracket, head shield	3-618-341	Support, S belt
3-618-216	Bracket, switch	3-618-342	Cover, rewind slide plate
3-618-217-06	Pushing Rod, switch	3-618-343	Record A2 (N)
3-618-220	Release Arm, tension regulator	3-618-344	Spacer, record A
3-618-223	SONY Emblem	3-618-345	Spring (N), record A
3-618-224	Plate, switch pushing	3-618-346	Spacer (N), record A
3-618-231-03	Support, front escutcheon (right)	3-618-347	Ground Plate, belt
3-618-232-03	Support, front escutcheon (left)	3-618-350-12	Sash
3-618-235	Spring, brake	3-618-351	Reel Shaft, supply
3-618-236	Plate Nut, ornamental panel	3-618-352	Reel Shaft, take-up
3-618-237	Holder, actuator	3-618-353	Retainer, reel table
3-618-238-02	Holder, shaft	3-618-357	Capstan Protector
3-618-239	Knob, hinge (AB)	3-618-361	UMBRAKO Set Screw M 2 x 5
3-618-240	Knob, hinge (AC)	3-618-362	Belt Ground Tip
3-618-241	Shaft, hinge (AB)	3-618-363	Anchor
3-618-242	Shaft, hinge (AC)	3-618-387	Hook
3-618-243	Rod (N), head cover	3-618-388	Sub-Pinch Roller Cushion
3-618-246	Release Rod, SP	3-618-501-04	Circuit Board, tape guide
3-618-247	Spacer, handle	3-618-510	Circuit Board, CTL head
3-618-248	Guide, tape	3-618-511	Supporting Plate, CTL
3-618-252-02	Collar, record link arm	3-618-517	Actuator
3-618-255	Cover, printed board	3-618-518-02	Rod, head guide
3-618-256	Shield, ornamental panel	3-618-519	Shaft, actuator
3-618-257	Shield Case, dummy coil	3-618-520	Plate, actuator
3-618-259-02	Shield Case, PRE AMP	3-618-522	Bracket, drum cover
3-618-260	Emblem, RF	3-618-523	Release Lever, actuator
3-618-261	Bracket (T), switch	3-618-525	Hanger, spring
3-618-262	Spring, hinge	3-618-529	Guide Roller
3-618-263	Spring, slide plate	3-618-601	Holder, Z board
3-618-264	Spring, release lever	3-618-602	Heat Sink (A)
3-618-265	Nameplate, battery pack set	3-618-603	Heat Sink (B)
3-618-267	Plastic Bag A	3-618-604	Heat Sink (R)
3-618-268	Emblem, patent	3-618-605	"V1" Board Shield Case
3-618-278	Spacer, REC-A1	3-618-606	Nameplate
3-618-280	Spacer, REC. lever	3-618-608	Standby Lever
3-618-285	Caution Label	3-618-609	Still Pulley Rod (A)
3-618-292	Emblem	3-618-714	Set Screw, 3 x 4
3-618-297	Spacer, battery	3-618-869	Spring
3-618-299	Spacer, sub pinch release	3-620-067	Retaining Ring
3-618-300	Lever, AF	3-620-143	Spring, rewind pulley
3-618-301	Spacer, connector	3-631-203	Stud, head cover
3-618-312	Spring A, still	3-631-204	Pulley, counter
3-618-313-03	Arm A, tension regulator release	3-701-020	Check Sheet Bag, SS
3-618-315	Spring A, stop	3-701-099	Set Screw, 3 x 3
3-618-316	Retainer, shaft	3-701-167	Screw, (+) B 4 x 28
3-618-319	Arm (2), reocrd link	3-790-587-11	Instruction Manual
3-618-321	Support (3), printed board	3-793-061-11	Warranty Card
3-618-322	Support (4), printed board	3-793-068-11	Caution Card
3-618-324-03	Release Rod, tension regulator	3-831-226	Panel, handle

<u>Part No.</u>	<u>Description</u>	<u>Part No.</u>	<u>Description</u>
4-002-839	Envelope, IBM card	7-682-151-01	(+) P 3 x 14
7-491-001	Desiccant	7-682-160-01	(+) P 4 x 6
8-880-053	Reel, RH-5E	7-682-161-01	(+) P 4 x 8
		7-682-246-01	(+) K 3 x 5
		7-682-247-01	(+) K 3 x 6
		7-682-249-01	(+) K 3 x 10
		7-682-346-05	(+) RK 3 x 5
		7-682-360-04	(+) RK 4 x 6
		7-682-360-05	(+) RK 4 x 6
		7-682-361-05	(+) RK 4 x 8
		7-682-545-04	(+) B 3 x 4
		7-682-545-05	(+) B 3 x 4
		7-682-547-04	(+) B 3 x 6
		7-682-548-05	(+) B 3 x 8
		7-682-554-05	(+) B 3 x 25
		7-682-560-04	(+) B 4 x 6
		7-682-646-001	(+) PS 3 x 5
		7-682-647-01	(+) PS 3 x 6
		7-682-648-01	(+) PS 3 x 8
		7-682-660-01	(+) PS 4 x 6
		7-682-661-01	(+) PS 4 x 8
		7-682-662-01	(+) PS 4 x 10
		7-685-145-01	(+) P 3 x 6
		7-623-104-12	1.7 mm dia (medium)
		7-623-105-12	2 mm dia (medium)
		7-623-108-02	3 mm dia (small)
		7-623-108-12	3 mm dia (medium)
		7-623-108-22	3 mm dia (large)
		7-623-110-02	4 mm dia (small)
		7-623-110-12	4 mm dia (medium)
		7-623-112-18	5 mm dia (medium)
		7-623-203-27	Spring Washer
		7-623-408-01	Lock Washer, external, 3 mm dia
		7-623-908-01	Fiber Washer
		7-623-910-03	Plastic Washer
		<u>NUTS</u>	
		7-622-305-05	2 mm dia
		7-684-013-00	3 mm dia
		<u>EYELETS</u>	
		7-624-101-01	1.2 mm dia
		7-624-102-01	1.5 mm dia
		7-624-105-01	2.3 mm dia
		7-624-107-01	3.2 mm dia
		7-624-108-01	4 mm dia
		<u>LUGS</u>	
		7-623-508-12	3 mm dia
		7-623-510-11	4 mm dia
<u>HEAD DRUM</u>			
8-829-510-12	Video Head, HO1-12		
8-945-530-50	Drum Ass'y, DA-1124	A-6009-016-A	
3-607-070	Brush		
3-612-922	Bracket, PG coil		
3-612-927	Mount, brush		
3-612-940	Bracket, brush		
3-613-208-01	Drum Pulley (brown) 21.47 mm dia		
3-613-208-02	Drum Pulley (red) 21.43 mm dia		
3-613-208-03	Drum Pulley (orange) 21.38 mm dia		
3-613-208-04	Drum Pulley (yellow) 21.34 mm dia		
3-613-208-05	Drum Pulley (green) 21.29 mm dia		
3-613-208-06	Drum Pulley (blue) 21.25 mm dia		
3-613-208-07	Drum Pulley (purple) 21.21 mm dia		
3-613-208-08	Drum Pulley (grey) 21.16 mm dia		
3-613-208-09	Drum Pulley (white) 21.12 mm dia		
3-613-208-10	Drum Pulley (black) 21.07 mm dia		
3-613-208-11	Drum Pulley (gold) 21.03 mm dia		
3-618-706-02	Drum, upper		
3-618-711	Shield Case, FG		
3-618-713	Retainer Lead Wire		
3-618-714	Set Screw, 3 x 4		
3-618-715	Retainer, drum lead		
7-621-255-15	(+) P 2 x 3		
7-621-255-25	(+) P 2 x 4		
7-621-255-33	(+) P 2 x 5		
7-621-255-37	(+) P 2 x 5		
7-621-259-35	(+) P 2.6 x 5		
7-621-259-45	(+) P 2.6 x 6		
7-621-281-58	(+) P 2.6 x 5		
7-621-555-20	(+) K 2 x 4		
7-621-555-23	(+) K 2 x 4		
7-621-555-37	(+) K 2 x 5		
7-621-559-35	(+) K 2.6 x 5		
7-621-659-37	(+) RK 2.6 x 5		
7-621-710-16	Set Screw, 2 x 2		
7-621-712-39	Set Screw, 2.6 x 4		
7-682-144-04	(+) P 3 x 3		
7-682-145-01	(+) P 3 x 4		
7-682-146-01	(+) P 3 x 5		
7-682-147-01	(+) P 3 x 6		
7-682-148-01	(+) P 3 x 8		
7-682-149-03	(+) P 3 x 10		

ELECTRICAL PARTS LIST

<u>Ref.</u> <u>No.</u>	<u>Part No.</u>	<u>Description</u>	<u>Ref.</u> <u>No.</u>	<u>Part No.</u>	<u>Description</u>
"V1" MODULATOR, REC/PB AMP			D104	1S1587	
			D105	1S1587	
8-984-055-00	"V1"	Printed Circuit Board, with components.	D106	1S1587	

CAPACITORS

All capacitors in microfarads unless otherwise indicated.
Tolerance of all silvered mica capacitors in $\pm 5\%$.
Tolerance of all mylar capacitors in $\pm 10\%$.
Tolerance of all electrolytic (elect) capacitors in $+100\%$, -10% .

C101	1-121-409-11	47	16 V, elect
C102	1-121-402-11	33	10 V, elect
C103	1-121-402-11	33	10 V, elect
C104	1-121-402-11	33	10 V, elect
C105	1-107-084-11	91 pF, silvered mica	
C106	1-121-403-11	33	16 V, elect
C107	1-107-081-11	62 pF, silvered mica	
C108	1-121-403-11	33	16 V, elect
C109	1-121-391-11	1	50 V, elect
C110	1-121-651-11	10	16 V, elect
C111	1-121-651-11	10	16 V, elect
C112	1-121-402-11	33	10 V, elect
C113	1-121-409-11	47	16 V, elect
C114	1-102-114-11	470 pF, $\pm 10\%$	50 V, ceramic
C115	1-121-403-11	33	16 V, elect
C116	1-121-403-11	33	16 V, elect
C117	1-121-419-11	220	6.3 V, elect
C118	1-105-681-12	0.047, mylar	
C119	1-141-070-11	20 pF, trimmer	
C120	1-107-163-11	47 pF, silvered mica	
C121	1-107-165-11	56 pF, silvered mica	
C122	1-105-681-12	0.047, mylar	
C123	1-121-392-11	3.3	25 V, elect
C201	1-121-391-11	1	50 V, elect
C202	1-105-681-12	0.047, mylar	
C203	1-105-681-12	0.047, mylar	
C204	1-105-681-12	0.047, mylar	
C205	1-105-681-12	0.047, mylar	
C221	1-105-681-12	0.047, mylar	
C222	1-141-070-11	20 pF, trimmer	
C223	1-105-681-12	0.047, mylar	
C224	1-105-681-12	0.047, mylar	
C225	1-105-681-12	0.047, mylar	
C226	1-141-070-11	20 pF, trimmer	
C228	1-105-681-12	0.047, mylar	
C229	1-105-681-12	0.047, mylar	
C230	1-121-651-11	10	16 V, elect
C231	1-105-673-12	0.01, mylar	

DIODES

D101	1T22
D102	1T22
D103	1S1587

INDUCTORS

L101	1-407-163	33 μ H, micro
L102	1-407-163	33 μ H, micro
L201	1-407-171	150 μ H, micro
L202	1-407-177	470 μ H, micro
L203	1-407-177	470 μ H, micro
L221	1-407-206	10 mH, micro
L222	1-407-206	10 mH, micro
L223	1-407-213	1.5 mH, micro

TRANSISTORS

Q101	2SK23A	FET
Q102	2SC403B	
Q103	2SC403B	
Q104	2SC403B	
Q105	2SC403B	
Q106	2SC403B	
Q107	2SC403B	
Q108	2SC403B	
Q109	2SC403C	
Q201	2SC403B	
Q202	2SC403B	
Q203	2SC1124	
Q204	2SC1124	
Q205	2SC1124	
Q221	2SK43	FET
Q222	2SC403B	
Q223	2SC403B	
Q224	2SK43	FET
Q225	2SC403B	
Q226	2SC403B	
Q227	2SC403B	

RESISTORS

Carbon resistors in ohms, 1/4 W, $\pm 5\%$ are omitted.

R101	1-242-633-11	22
R102	1-242-646-11	75
R103	1-242-685-11	3300
R104	1-242-745-11	1 M
R105	1-242-693-11	6800
R106	1-221-694-11	20 k (B), semi-fixed
R107	1-242-709-11	33 k
R108	1-242-693-11	6800
R109	1-242-673-11	1 k
R110	1-242-657-11	220

<u>Ref. No.</u>	<u>Part No.</u>	<u>Description</u>
R111	1-242-673-11	1 k
R112	1-242-721-11	100 k
R113	1-242-702-11	16 k
R114	1-242-675-11	1200
R115	1-242-651-11	120
R116	1-221-494-11	500 (B), semi-fixed
R117	1-242-675-11	1200
R118	1-242-675-11	1200
R119	1-242-643-11	56
R120	1-242-685-11	3300
R121	1-242-673-11	1 k
R122	1-242-664-11	430
R123	1-242-665-11	470
R124	1-242-657-11	220
R125	1-242-697-11	10 k
R126	1-242-690-11	5100
R127	1-221-497-11	5 k (B), semi-fixed
R128	1-221-494-11	500 (B)
R129	1-242-633-11	22
R130	1-242-649-11	100
R131	1-242-658-11	240
R132	1-242-658-11	240
R133	1-242-661-11	330
R134	1-242-661-11	330
R135	1-242-681-11	2200
R137	1-221-494-11	500 (B), semi-fixed
R138	1-242-625-11	10
R139	1-242-625-11	10
R140	1-242-643-11	56
R141	1-242-671-11	820
R142	1-242-644-11	62
R143	1-242-721-11	100 k
R144	1-242-721-11	100 k
R201	1-221-492-11	100 (B), semi-fixed
R202	1-242-703-11	18 k
R203	1-242-684-11	3 k
R204	1-242-680-11	2 k
R205	1-242-660-11	300
R206	1-242-666-11	510
R207		6200
R208	1-242-680-11	2 k
R209	1-221-492-11	100 (B), semi-fixed
R210	1-242-633-11	22
R211	1-221-492-11	100 (B), semi-fixed
R212	1-242-633-11	22
R221	1-242-646-11	75
R222	1-221-498-11	10 k (B), semi-fixed
R223	1-242-708-11	30 k
R226	1-221-498-11	10 k (B), semi-fixed
R227	1-242-708-11	30 k
R228	1-242-697-11	10 k
R229	1-242-704-11	20 k
R230	1-242-681-11	2200
R231	1-242-677-11	1500

<u>Ref. No.</u>	<u>Part No.</u>	<u>Description</u>
-----------------	-----------------	--------------------

TRANSFORMER

T101	1-425-383	Transformer
T221	1-423-158	Transformer
T222	1-423-158	Transformer

SWITCH

S7	1-514-813	Slide Switch
----	-----------	--------------

"D1" DEMODULATOR

8-984-055-20 "D1" Printed Circuit Board, with components.

CAPACITORS

All capacitors in microfarads unless otherwise indicated.
All mylar capacitors in 50 V.
Tolerance of all electrolytic (elect) capacitors in +100%, -10%.

C301	1-121-391-11	10	25 V, elect
C302	1-105-685-12	0.1, mylar	
C303	1-107-121-11	39 pF	50 V, silvered mica
C304	1-105-673-12	0.01	50 V, silvered mica
C305	1-105-673-12	0.01	50 V, silvered mica
C306	1-121-398-11	10	25 V, elect
C307	1-105-685-12	0.1, mylar	
C308	1-105-673-12	0.01, mylar	
C309	1-105-673-12	0.01, mylar	
C310	1-105-673-12	0.01, mylar	
C311	1-121-398-11	10	25 V, elect
C312	1-105-685-12	0.1, mylar	
C313	1-105-673-12	0.01, mylar	
C314	1-105-673-12	0.01, mylar	
C315	1-105-673-12	0.01, mylar	
C316	1-105-673-12	0.01, mylar	
C317	1-105-673-12	0.01, mylar	
C318	1-105-673-12	0.01, mylar	
C319	1-121-391-11	10	25 V, elect
C320	1-105-685-12	0.1, mylar	
C321	1-105-673-12	0.01, mylar	
C322	1-105-673-12	0.01, mylar	
C323	1-121-403-11	33	16 V, elect
C324	1-101-439-11	680 pF, ±20%	50 V, ceramic
C325	1-121-403-11	33	16 V, elect
C326	1-121-403-11	33	16 V, elect
C327	1-121-403-11	33	16 V, elect
C328	1-121-391-11	1	50 V, elect
C329	1-102-098-11	470 pF, ±20%	50 V, ceramic
C330	1-105-661-12	0.001, mylar	
C331	1-121-391-11	1	50 V, elect
C332	1-107-131-11	100 pF	50 V, silvered mica
C333	1-105-673-12	0.01, mylar	
C334	1-121-403-11	33	16 V, elect
C335	1-121-409-11	47	16 V, elect

Ref. No. Part No. Description

DIODES

D301 1S1925
D302 1S1925
D303 1S1555
D304 1S1555
D305 1S1555

D306 1S1555
D307 1S1555
D308 1S1555
D309 1S1555
D310 1S1555

D311 1S1925
D312 1S1925

INDUCTORS

L301 1-407-255 47 μ H, variable
L302 1-407-177 470 μ H, micro
L303 1-407-201 3.9 mH, micro
L304 1-407-174 270 μ H, micro
L305 1-407-201 3.9 mH, micro

L306 1-407-174 270 μ H, micro
L307 1-407-174 270 μ H, micro
L308 1-407-201 3.9 mH, micro
L309 1-407-174 270 μ H, micro

TRANSISTORS

Q301 2SC403C
Q304 2SC403C
Q315 2SC1124

RESISTORS

Carbon resistors in ohms, 1/4 W, $\pm 5\%$ are omitted.

R301 1-242-655-11 180
R302 1-242-719-11 82 k
R303 1-242-697-11 10 k
R304 1-221-498-11 10 k (B), semi-fixed
R305 1-242-680-11 2 k

R306 1-242-644-11 62
R307 1-242-666-11 510
R308 1-242-711-11 39 k
R309 1-242-677-11 1500
R310 1-242-657-11 220

R311 1-242-657-11 220
R312 1-242-703-11 18 k
R313 1-242-703-11 18 k
R314 1-242-666-11 510
R315 1-224-073-11 100 k (B)

Ref. No. Part No. Description

R316 1-242-695-11 8200
R317 1-242-677-11 1500
R318 1-242-635-11 150
R319 1-242-703-11 18 k
R320 1-242-703-11 18 k

R321 1-242-666-11 510
R322 1-242-718-11 75 k
R323 1-242-695-11 8200
R324 1-242-677-11 1500
R325 1-242-645-11 68

R326 1-242-703-11 18 k
R327 1-242-703-11 18 k
R328 1-242-666-11 510
R329 1-242-718-11 75 k
R330 1-242-695-11 8200

R331 1-242-677-11 1500
R332 1-242-645-11 68
R333 1-242-713-11 47 k
R334 1-242-697-11 10 k
R335 1-242-658-11 240

R336 1-242-704-11 20 k
R337 1-221-492-11 100 (B), semi-fixed
R338 1-242-684-11 3 k
R339 1-242-661-11 330
R340 1-242-661-11 330

R341 1-242-673-11 1 k
R342 1-242-645-11 68
R343 1-221-495-11 1 k (B), semi-fixed
R344 1-242-637-11 33
R345 1-242-717-11 68 k

R346 1-242-700-11 13 k
R347 1-242-673-11 1 k
R348 1-242-643-11 56
R349 1-242-680-11 2 k
R350 1-242-666-11 510

R351 1-242-697-11 10 k
R352 1-242-696-11 9100
R353 1-242-673-11 1 k
R354 1-242-680-11 2 k
R355 1-242-646-11 75

R356 1-242-685-11 3300
R357 1-242-695-11 8200
R358 1-244-837-11 33, 1/2 W
R359 1-242-661-11 330
R360 1-242-699-11 12 k

R361 1-242-697-11 10 k
R362 1-242-666-11 510
R363 1-242-649-11 100

FILTER

FL301 1-231-100 Low-pass filter

<u>Ref. No.</u>	<u>Part No.</u>	<u>Description</u>
TRANSFORMER		
T301	1-425-202	Transformer
"S1" SERVO		
8-984-055-30	"S1" Printed Circuit Board, with components.	

CAPACITORS

All capacitors in microfarads unless otherwise indicated.
 All mylar capacitors in $\pm 10\%$, 50 V.
 All silvered mica capacitors in $\pm 5\%$, 50 V.
 Tolerance of all electrolytic (elect) capacitors in +150%, -10%.

C601	1-105-669-12	0.0047, mylar
C602	1-105-673-12	0.01, mylar
C603	1-121-409-11	47 16 V, elect
C604	1-121-391-11	1 50 V, elect
C605	1-121-391-11	1 50 V, elect
C606	1-105-677-12	0.022, mylar
C607	1-105-661-12	0.001, mylar
C608	1-121-391-11	1 50 V, elect
C609	1-121-391-11	1 50 V, elect
C610	1-121-409-11	47 16 V, elect
C611	1-107-093-11	220 pF, silvered mica
C612	1-107-089-11	150 pF, silvered mica
C613	1-107-093-11	220 pF, silvered mica
C614	1-107-093-11	220 pF, silvered mica
C615	1-107-093-11	220 pF, silvered mica
C616	1-121-409-11	47 16 V, elect
C617	1-105-661-12	0.001, mylar
C618	1-105-669-12	0.0047, mylar
C619	1-107-083-11	82 pF, silvered mica
C620	1-121-409-11	47 16 V, elect
C621	1-121-421-11	220 16 V, elect
C622	1-121-413-11	100 6.3 V, elect
C623	1-105-685-12	0.1, mylar
C624	1-121-404-11	33 25 V, elect
C625	1-129-670-21	220 pF, 50 V, neo-polyethylene
C651	1-105-661-12	0.001, mylar
C652	1-121-398-11	10 25 V, elect
C653	1-121-391-11	1 50 V, elect
C654	1-107-085-11	100 pF, silvered mica
C655	1-121-391-11	1 50 V, elect
C656	1-121-409-11	47 16 V, elect
C657	1-107-085-11	100 pF, silvered mica
C658	1-105-681-12	0.047, mylar
C659	1-121-409-11	47 16 V, elect
C670	1-105-681-12	0.047, mylar
C701	1-121-469-11	10 10 V, elect
C702	1-105-673-12	0.01, mylar
C703	1-105-673-12	0.01, mylar
C704	1-121-398-11	10 25 V, elect
C705	1-121-413-11	100 6.3 V, elect

<u>Ref. No.</u>	<u>Part No.</u>	<u>Description</u>
C706	1-105-677-12	0.022, mylar
C707	1-121-469-11	10 10 V, elect
C708	1-121-403-11	33 16 V, elect
C709	1-121-403-11	10 16 V, elect
C710	1-121-398-11	10 25 V, elect
C711	1-107-087-11	120 pF, silvered mica
C712	1-105-685-12	0.1, mylar
C713	1-121-398-11	10 25 V, elect
C714	1-121-391-11	1 50 V, elect
C715	1-105-673-12	0.01, mylar
C716	1-105-673-12	0.01, mylar
C717	1-105-677-12	0.022, mylar
C718	1-131-215-11	1 35 V, tantalum capacitor
C719	1-105-661-12	0.001, mylar
C720	1-121-398-11	10 25 V, elect
C721	1-121-409-11	47 16 V, elect
C722	1-121-392-11	3.3 25 V, elect
C723	1-131-212-11	0.33 35 V, tantalum capacitor
C724	1-105-673-12	0.01, mylar
C725	1-105-681-12	0.047, mylar
C726	1-121-398-11	10 25 V, elect
C727	1-121-403-11	33 16 V, elect
C728	1-121-391-11	1 50 V, elect
C729	1-121-391-11	1 50 V, elect
C730	1-105-667-12	0.0033, mylar
C731	1-105-667-12	0.0033, mylar
C732	1-105-681-12	0.047, mylar
C733	1-105-681-12	0.047, mylar
C734	1-107-095-11	270 pF, silvered mica
C735	1-107-095-11	270 pF, silvered mica
C736	1-121-391-11	1 50 V, elect
C737	1-105-667-12	0.0033, mylar
C738	1-121-409-11	47 16 V, elect
C739	1-131-213-11	0.47 35 V, tantalum capacitor
C740	1-105-667-12	0.0033, mylar
C741	1-121-409-11	47 16 V, elect
C742	1-131-213-11	0.47 35 V, tantalum capacitor
C743	1-105-661-12	0.001, mylar
C744	1-121-409-11	47 16 V, elect
C745	1-131-213-11	0.47 35 V, tantalum capacitor
C746	1-105-673-12	0.01, mylar
R747	1-105-685-12	0.1, mylar
R748	1-105-685-12	0.1, mylar
R749	1-105-685-23	0.1, mylar
R750	1-121-421-11	220 16 V, elect
R751	1-121-398-11	10 25 V, elect
R752	1-121-391-11	1 50 V, elect

DIODES

D601	1S1587
D602	1S1587
D603	1T22
D610	1T22

<u>Ref. No.</u>	<u>Part No.</u>	<u>Description</u>
D701	1T22	
D702	1S1555	
D703	1S1555	
D704	1S1555	
D706	1T22	
D707	1T22	
D708	1T22	

INDUCTORS

L602	1-407-208-11	15 mH, micro
L603	1-407-173-11	220 μ H, micro

TRANSISTORS

Q601	2SC633	
Q607	2SC633	
Q608	2SC403C	
Q609	2SD291	
Q651	2SC633	
Q652	2SC633	
Q653	2SA678	
Q654	2SC403C	
Q701	2SC633	
Q702	2SC633	
Q703	2SC403C	
Q704	2SA677	
Q705	2SC633	
Q706	2SA678	
Q707	2SC403C	
Q708	2SK23A	
Q709	2SC403C	
Q710	2SC403C	
Q711	2SC403C	
Q712	2SC633	
Q713	2SC633	
Q714	2SC403C	
Q715	2SC403C	
Q716	2SC403C	
Q717	2SC1124	
Q718	2SB324	
Q719	2SD291	
Q720	2SB481J	

IC

IC601	8-755-060-00	CX-506
IC651	8-759-411-60	MN-116
IC701	8-755-060-00	CX-506

RESISTORS

Carbon resistors in ohms, 1/4 W, $\pm 5\%$ are omitted.

<u>Ref. No.</u>	<u>Part No.</u>	<u>Description</u>
R601	1-242-649-11	100
R602	1-242-715-11	56 k
R603	1-242-697-11	10 k
R604	1-242-683-11	2700
R605	1-242-657-11	220
R606	1-242-709-11	33 k
R607	1-242-697-11	10 k
R608	1-242-683-11	2700
R609	1-242-657-11	220
R610	1-242-673-11	1 k
R611	1-242-711-11	39 k
R612	1-242-711-11	39 k
R613	1-242-666-11	510
R614	1-242-697-11	10 k
R615	1-242-681-11	2200
R616	1-242-680-11	2 k
R617	1-242-685-11	3300
R618	1-242-713-11	47 k
R619	1-242-695-11	8200
R620	1-242-697-11	10 k
R621	1-221-496-11	2 k (B), semi-fixed
R622	1-242-693-11	6800
R623	1-242-656-11	200
R624	1-242-689-11	4700
R625	1-242-644-11	62
R626	1-242-680-11	2 k
R627	1-242-670-11	750
R629	1-242-713-11	47 k
R651	1-242-721-11	100 k
R652	1-242-717-11	68 k
R653	1-242-689-11	4700
R654	1-242-666-11	510
R655	1-242-713-11	47 k
R656	1-242-697-11	10 k
R657	1-242-673-11	1 k
R658	1-242-689-11	4700
R659	1-242-697-11	10 k
R660	1-242-697-11	10 k
R661	1-242-642-11	51
R662	1-242-697-11	10 k
R663	1-242-697-11	10 k
R664	1-242-680-11	2 k
R665	1-242-697-11	10 k
R667	1-242-673-11	1 k
R668	1-242-685-11	3300
R669	1-242-680-11	2 k
R670	1-242-705-11	22 k
R671	1-242-673-11	1 k
R701	1-242-715-11	56 k
R702	1-242-696-11	9100
R703	1-242-696-11	9100
R704	1-242-673-11	1 k
R705	1-242-720-11	91 k
R706	1-242-692-11	6200
R707	1-242-696-11	9100

<u>Ref. No.</u>	<u>Part No.</u>	<u>Description</u>
R708	1-242-673-11	1 k
R709	1-242-633-11	22
R710	1-242-682-11	2400
R711	1-242-637-11	33
R712	1-242-666-11	510
R713	1-242-665-11	470
R714	1-242-700-11	13 k
R715	1-242-727-11	180 k
R716	1-242-691-11	5600
R717	1-242-697-11	10 k
R718	1-242-697-11	10 k
R719	1-242-713-11	47 k
R720	1-242-697-11	10 k
R721	1-242-691-11	5600
R722	1-242-711-11	39 k
R723	1-242-690-11	5100
R724	1-242-701-11	15 k
R725	1-242-673-11	1 k
R726	1-242-681-11	2200
R727	1-242-685-11	3300
R728	1-242-713-11	47 k
R729	1-242-697-11	10 k
R730	1-242-649-11	100
R731	1-224-073-11	100 k (B), semi-fixed
R732	1-221-694-11	20 k (B), semi-fixed
R733	1-242-742-11	750 k
R734	1-242-680-11	2 k
R735	1-242-719-11	82 k
R736	1-242-690-11	5100
R737	1-242-697-11	10 k
R738	1-242-709-11	33 k
R739	1-242-709-11	33 k
R740	1-242-711-11	39 k
R741	1-242-680-11	2 k
R742	1-242-701-11	15 k
R743	1-242-690-11	5100
R744	1-242-721-11	100 k
R745	1-242-705-11	22 k
R747	1-242-721-11	100 k
R748	1-242-666-11	510
R749	1-242-713-11	47 k
R750	1-242-691-11	5600
R751	1-221-681-11	50 k (B), semi-fixed
R752	1-242-703-11	18 k
R753	1-242-705-11	22 k
R754	1-242-712-11	43 k
R755	1-242-673-11	1 k
R756	1-242-685-11	3300
R758	1-242-717-11	68 k
R759	1-242-649-11	100
R760	1-242-697-11	10 k
R761	1-242-703-11	18 k
R762	1-242-660-11	300
R764	1-242-673-11	1 k

<u>Ref. No.</u>	<u>Part No.</u>	<u>Description</u>
R765	1-242-705-11	22 k
R766	1-242-704-11	20 k

TRANSFORMER

T601	1-427-265	Transformer
T701	1-427-265	Transformer

SWITCH

1-514-813-22	Slide Swtich
--------------	--------------

X'TAL O. S. C

X651	1-527-153	31.25 kHz, X'tal O. S. C
------	-----------	--------------------------

"A1" AUDIO

8-984-055-50	"A1" Printed Circuit Board, with components.
--------------	--

CAPACITORS

All capacitors in microfarads unless othrewise indicated.
 All mylar capacitors in $\pm 10\%$, 50 V.
 Tolerance of all electrolytic (elect) capacitors as follows
 less than 10 μF = +150%, -10%
 10 μF and over = +100%, -10%

C801	1-121-398-11	10	25 V, elect
C802	1-121-421-11	220	16 V, elect
C803	1-121-415-11	100	16 V, elect
C804	1-121-398-11	10	25 V, elect
C805	1-121-403-11	33	16 V, elect
C806	1-105-677-12	0.022, mylar	
C807	1-121-409-11	47	16 V, elect
C808	1-121-398-11	10	25 V, elect
C809	1-121-398-11	10	25 V, elect
C810	1-121-413-11	100	6.3 V, elect
C811	1-131-213-11	0.47	35 V, tantalum capacitor
C812	1-105-667-12	0.0033, mylar	
C813	1-105-661-12	0.001, mylar	
C814	1-107-095-11	270 pF $\pm 5\%$	50 V, silvered mica
C815	1-121-398-11	10	25 V, elect
C816	1-121-413-11	100	6.3 V, elect
C817	1-121-413-11	100	6.3 V, elect
C818	1-121-403-11	33	16 V, elect
C819	1-121-409-11	47	16 V, elect
C820	1-121-391-11	1	50 V, elect
C821	1-121-421-11	220	16 V, elect
C822	1-121-391-11	1	50 V, elect
C823	1-121-413-11	100	6.3 V, elect
C824	1-121-420-11	220	6.3 V, elect
C825	1-105-677-12	0.0022, mylar	

<u>Ref. No.</u>	<u>Part No.</u>	<u>Description</u>
C826	1-105-675-12	0.015, mylar
C827	1-121-415-11	100 6.3 V, elect
C828	1-129-708-11	0.0033 630 V, combination capacitor
C829	1-141-034-21	30 pF ~ 200 pF, trimmer
C830	1-105-665-12	0.0022, mylar
C831	1-121-391-11	1 50 V, elect
C832	1-103-721-11	680 pF 50 V, neo-polyethylene

DIODES

D801	1T22
D802	1T22

INDUCTORS

L801	1-409-094	20 mH, variable
L802	1-407-202	4.7 mH, micro
L803	1-407-090	Dummy Coil

TRANSISTORS

Q801	2SC631
Q802	2SC631
Q803	2SC633
Q806	2SC633
Q807	2SC677
Q808	2SC1124

RESISTORS

Carbon resistors in ohms, 1/4 W, ±5% are omitted.

R801	1-242-725-11	150 k
R802	1-242-717-11	68 k
R803	1-242-703-11	18 k
R804	1-242-701-11	15 k
R805	1-242-649-11	100
R806	1-242-687-11	3900
R807	1-242-725-11	150 k
R808	1-242-707-11	27 k
R809	1-221-497-11	5 k (B), semi-fixed
R810	1-242-712-11	43 k
R811	1-242-687-11	3900
R812	1-242-673-11	1 k
R813	1-242-681-11	2200
R814	1-221-681-11	50 k (B), semi-fixed
R815	1-221-707-11	27 k
R816	1-221-699-11	12 k
R817	1-221-673-11	1 k
R818	1-242-665-11	470
R819	1-242-641-11	47
R820	1-242-691-11	5600

<u>Ref. No.</u>	<u>Part No.</u>	<u>Description</u>
R821	1-242-689-11	4700
R822	1-242-681-11	2200
R823	1-242-649-11	100
R824	1-242-709-11	33 k
R825	1-242-699-11	12 k
R826	1-221-497-11	5 k (B), semi-fixed
R827	1-242-673-11	1 k
R828	1-242-663-11	390
R829	1-242-699-11	12 k
R830	1-242-693-11	6800
R831	1-242-665-11	470
R832	1-242-697-11	10 k
R833	1-242-695-11	8200
R834	1-242-730-11	240 k
R835	1-242-703-11	18 k
R836	1-242-697-11	10 k
R837	1-242-675-11	1200
R838	1-242-609-11	2.2
R839	1-244-841-11	47, 1/2 W
R840	1-242-632-11	20
R841	1-242-713-11	47 k
R842	1-242-649-11	100

TRANSFORMER

T811	1-433-139	O. S. C. Transformer
------	-----------	----------------------

SWITCH

1-514-861-22	Slide Switch
--------------	--------------

"R1" REGULATOR

8-984-055-60	"R1" Printed Circuit Board, with components.
--------------	--

CAPACITORS

Tolerance of all electrolytic (elect) capacitors in +50%, -10%.

C901	1-121-415-11	100 μF	16 V, elect
C902	1-121-421-11	100 μF	16 V, elect
C903	1-121-398-11	10 μF	25 V, elect

DIODES

D901	RD-5A
------	-------

TRANSISTORS

Q901	2SD291
Q902	2SC403C
Q903	2SC403C

Ref.
No. Part No. Description

RESISTORS

Carbon resistors in ohms, 1/4 W, ±50% are omitted.

R906 1-242-667-11 560
R907 1-221-495-11 1 k (B), semi-fixed
R908 1-242-673-11 1 k
R909 1-242-663-11 390
R911 1-242-685-11 3300

R912 1-221-497-11 5 k (B), semi-fixed
R913 1-242-675-11 1200

"Z" BOARD

8-984-055-40 "Z" Printed Circuit Board, with components.

CAPACITORS

C951 1-121-398-11 10 μF ±10% 25 V, electrolytic

DIODES

D951 1S1555
D952 1S1555

TRANSISTORS

Q951 2SC403C
Q952 2SC1124
Q953 2SA678
Q954 2SC403C
Q955 2SC1124

RESISTORS

R951 1-242-689-11 4700
R952 1-242-709-11 33 k
R953 1-242-643-11 470
R954 1-242-673-11 1 k
R955 1-242-673-11 1 k

Ref.
No. Part No. Description

R956 1-242-643-11 470
R957 1-242-673-11 1 k
R958 1-242-689-11 4700
R959 1-242-709-11 33 k
R960 1-242-643-11 470

HEAD DRUM

1-419-019-51 PG Coil, 25 PG
1-419-019-61 PG Coil, 50 PG
1-426-037-11 Coil, FG
1-514-039-12 Micro Switch
1-536-199-11 Lug Terminal, FG

1-536-255-11 Terminal Strip, brush
1-539-369-11 Terminal Board, brush
8-821-221-04 Audio Head, CTL head
8-825-567-00 Erase Head
8-829-510-12 Video Head, HO1-12

FRAME

D901 10D-2 Diode
D953 SD-102 Diode
D954 SD-102 Diode

L601 1-409-094 Trap Coil

1-454-103 Solenoid Plunger
1-507-901 Jack Nut
1-514-545 Micro Switch
1-514-584 Leaf Switch
1-514-861 Slide Switch

1-516-241 Leaf Switch, still
1-520-079 Level Meter, battery level
~~1-532-200~~ ~~Fuse 3 A~~
1-533-040 Fuse Holder
1-536-395 Solder Terminal, 1 L 1

1-539-324-14 "F" Printed Circuit Board
1-539-814-12 "L" Printed Circuit Board
8-834-603-00 Sub-motor, D603

Note: The components identified by shading are critical for safety. Replace only with part number specified.

SONY CORPORATION

9-966-164-01

1978.8 0910-6
© Printed in Japan