



### GENERAL INFORMATION

The Garrard Models RC-98 and RC-88 Record Changers are designed to play standard 78 RPM, fine-groove 45 RPM, or micro-groove 33 1/3 RPM records of standard commercial dimensions. Records up to 12 inches in diameter can be played.

Features of Models RC-98 and RC-88 Changers include playing and automatically changing as many as eight records, 10" or 12", not mixed. A full stack of eight 7", 33 1/3 RPM records or a full stack of eight 7", 45 RPM records (using the "45" Adaptor Spindle) will also play on this changer.

A short spindle for use when playing small hole records manually and an adaptor for playing large hole 45 RPM records manually is supplied with the changers.

These changers automatically shuts off after the last record has been played.

Models RC-98 and RC-88 is suitable for use on 100/130 or 200/250 volts, at either 50 or 60 cycles according to the motor pulley supplied.

**Manufactured by:**

Garrard Engineering & Mfg. Co., Ltd.  
Newcastle Street  
Swindon, Wilts — England

**U. S. Distributor:**

Garrard Sales Corporation  
164 Duane Street  
New York 13, N. Y.

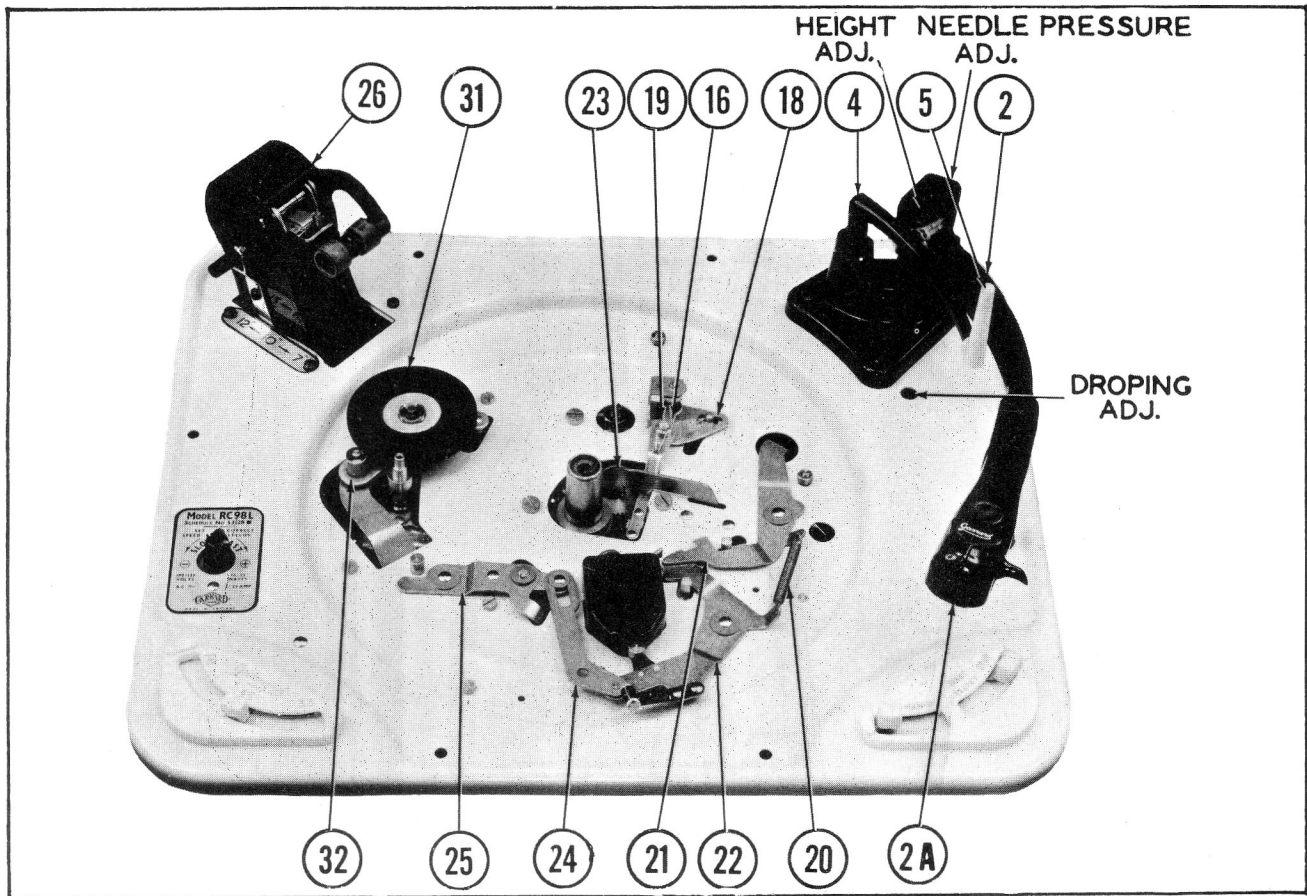

Figure 1

## OPERATING INSTRUCTIONS

1. Insert the interchangeable plug-in head that accommodates user's personal choice of crystal, ceramic, or magnetic cartridges; turnover, twist, or simple plug-in types.

2. Place the correct spindle in position, the stepped sloping spindle for 78 or 33 1/3 RPM records, or the large spindle for 45 RPM records.

3. Set lever (28) at side of record platform (26) to position corresponding to size of record to be played.

4. Move speed control knob to desired speed, 78, 45, or 33 1/3 RPM.

5. Place any number of records up to eight, on the record spindle, lower record clip, and switch on by moving the front left hand knob (47) to "Start".

NOTE: When playing 7" 45 RPM record clip must be in the rear position.

### To Reject A Record-

To reject a record at any time while changer is operating, move the right hand knob to "Reject" position and release.

### Stopping-

If it is desired to stop the changer before it does so automatically, move the right hand knob to "Stop" position. If this is done while a record is playing that record will be rejected on switching on again.

### Speed Regulation-

A variable speed control is fitted on the Model RC-98 and to set the speed accurately proceed as instructed under "Operating Instructions." Place one record on record spindle and switch on. When pickup commences to play place stroboscope disc, supplied with changer, on record and turn speed adjusting knob until the ring of dots on the stroboscope, coinciding with the speed indicated by the speed change knob, appears to remain stationary when viewed by light from a lamp on the appropriate AC power supply. The speed will now be correct.

### Manual Operation-

The purpose of the manual control is to disconnect the changing mechanism so that single records can be played as on a single record player. To use this feature, move the Manual/Auto knob to the Manual position, fit short spindle, supplied with unit, and switch on changer to allow the mechanism to complete its cycle. The pickup will then be free on its rest and can be handled and the unit used as a single record player. At the completion of the record the pickup will rise and return to its rest, leaving the turntable revolving. To stop motor and turntable, move right hand control knob to "Stop". On switching on again time must be allowed for unit to complete cycle once again.

NOTE: Should the record changer be stopped with the pickup arm not on its rest while the unit is set to Auto, the pickup should not be handled but the right hand knob should be moved to "Start" then the mechanism will operate and

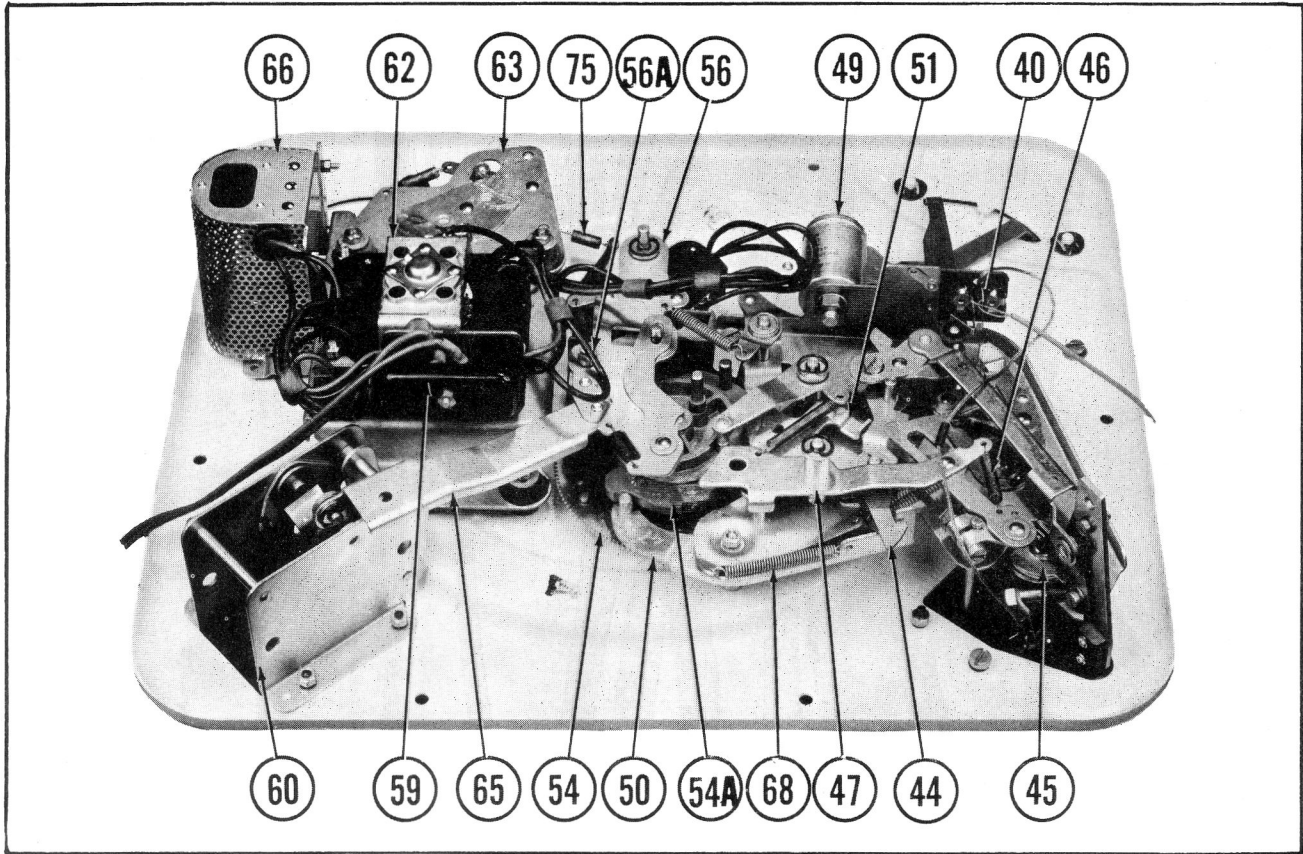

Figure 2

the pickup will lift to its rest. The pickup arm will not move from its rest unless one or more records are on the record spindle. This is a safety device designed to prevent the pickup being damaged should the changer be switched on without being loaded with records.

### CHANGE CYCLE

The change cycle is put into operation by moving the "Stop-Start-Reject" knob (33) to "Reject" as knob is moved to "Reject" position several associated parts move simultaneously. Switch lever (22) latches with switch catch lever (21) closing switch (20). The motor is started and inter wheel (31) makes firm contact with motor pulley thru tension applied by support lever (74) spring, thus moving inter wheel (31) against the turntable rim rotating turntable (15). Reject lever (33) also moves stop actuating lever (34), which raises the stop lever (23) out of its stop position, releasing cycling gear (54) and cycling cam (54A), which are secured together and move in unison.

As the cycling gear (54) and cycling cam (54A) revolve, the lifting lever (45) is pivoted, due to the cam roller on lever (45) following the contour of cycling cam (54A). This, in turn, through its connected cam roller, closes the muting switch (40) and actuates the lifting crank (45A) which raises the lifting plate and spindle (38), thus raising the tone arm (2).

At this time, cycling cam (54A) makes contact with the shut-off cam lever (47) which pulls size selector & switch off arm (4) inward; however, with records on the spindle, the arm (4) is blocked from making its full inward travel, thereby preventing the shut off operation.

At this position of cam rotation, cycling cam (54A) pushes coupling link (65) back. This, in turn, actuates the record dropping mechanism, thus selecting the bottom record and dropping it to the turntable. At the same time, the 45 RPM spindle actuating lever assembly (53) is pivoted by cycling cam (54A). This actuates the 45 RPM spindle when it is used.

Cycling cam (54A) pivots the pickup actuating lever (50), causing its roller to engage the pickup lever (36) which, in turn, moves the tone arm outward. Now, the stud on the tone arm index lever (41) makes contact with the pickup lever (36) and moves the tone arm inward, by action of the index lever springs (42) and (43), until the ear on the tone arm index lever (41) contacts one of the set down steps on tone arm locator lever (44). The set down step in which the ear of tone arm index lever (41) engages is determined by the size record being played. This position the pickup arm for set down.

Lifting lever (45) now returns to its normal position; and, through the connected parts, the tone arm is lowered to the record and the muting switch (40) is opened.

At this time, by action of cycling cam (54A) and cycling gear (54) revolving in unison, the stop lever (23) reach a point on the cycling gear (54), where the stop lever (23) stops the cycling gear (54), and the teeth run out. The revolving of the turntable has no effect on the cycling gear (54), because of stop lever holding the cycling gear (54), this completes the change cycle.

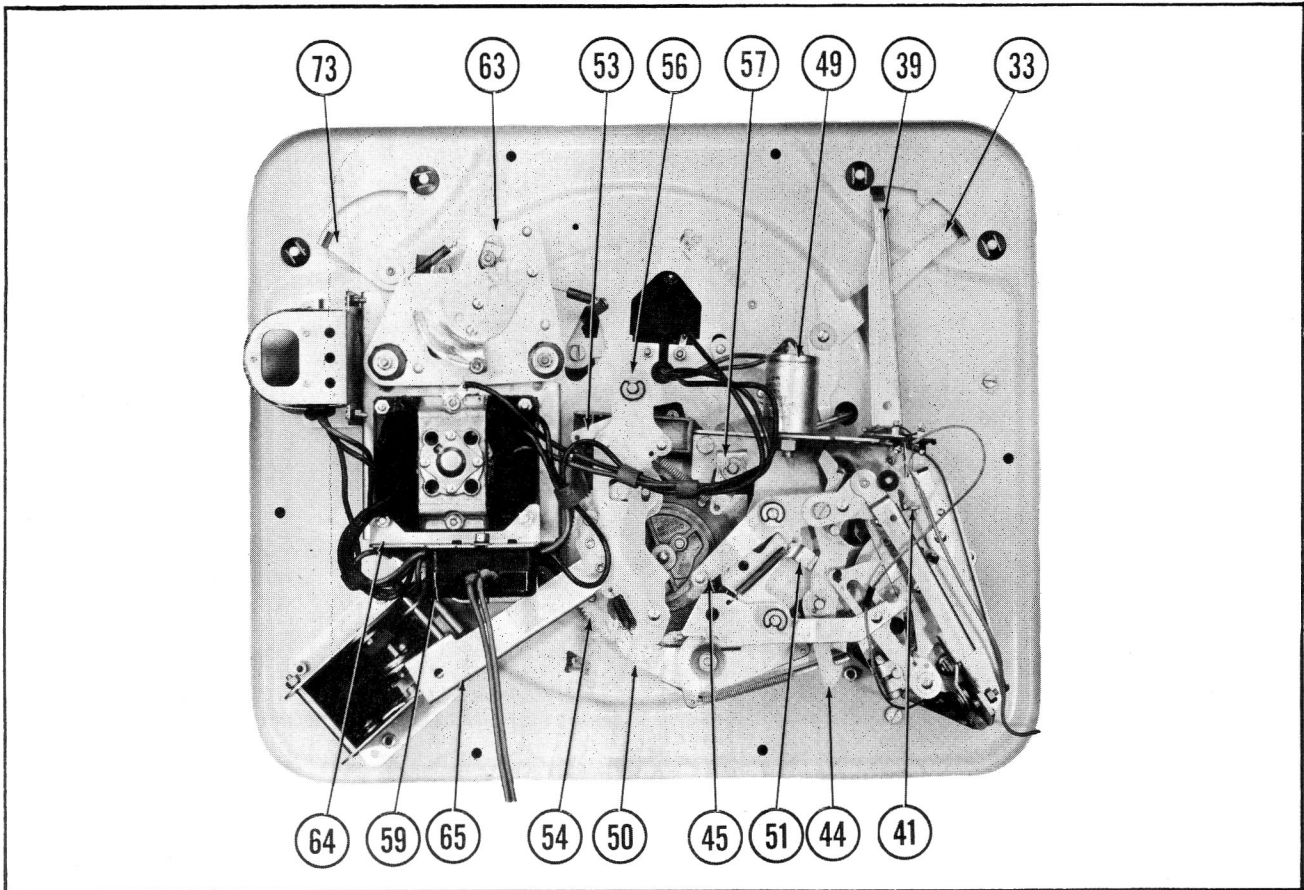

Figure 3

As the needle follows the grooves of a record and moves the tone arm in toward the spindle, pickup lever (36), which is secured to the tone arm shaft (38), engages and moves the auto trip actuating lever (48). This in turn, pivots friction plate (18) and automatic trip lever (16) toward main spindle (52A). While a record is playing, the slight inward movement by automatic trip lever (16) is not sufficient to trip the mechanism, because, on each revolution of main spindle (52A), the wiping contact by the spindle striker moves the automatic trip lever (16) back.

When the tone arm reaches the end of the music grooves, its movement is accelerated. This increase the movement of the automatic trip lever (16) which is caught by the striker on main spindle (52A) and lifted. This in turn lifts the stop lever (23) up and out of the notch in the cycling gear. The cycling gear (54) is then free to rotate, this starts the mechanism in to cycle.

### AUTOMATIC SHUT-OFF

When the last record has been played, the change cycle starts again. Since there are no records on the spindle, the size selector and switch off arm (4) is allowed to move in far enough for shut-off lever (47) to push pickup locator lever (44), which latches pickup actuating lever (50) so that its outward travel is stopped. When cycling cam (54A) rotates, the pickup actuating lever (50) is held so that the protrusion on the pickup actuating lever moves to the outside of the cycling cam (54A), thereby, pushing pickup actuating lever (50) into the catch lever (21), releasing switch lever (22), which shuts off unit.

### ADJUSTMENTS

#### Pickup Height Adjustment-

The distance the pickup lifts can be adjusted by turning the screw (3) on top of pickup arm, see Figure (1), with a small screwdriver. Eight 12" 78 RPM records should be placed on the turntable and the pick-up height adjusted so that as the pickup returns to the rest on completion of the top record the tip of the pickup stylus clears the record surface by 1/8".

#### Pickup Dropping Position Adjustment-

The pickup arm dropping position is factory set for optimum accuracy but should any minor adjustment be required to accommodate abnormal records, rotate the screw accessible through the hole in the unit plate as shown in Figure (1). This adjustment can only be made with the pickup arm on its rest.

#### Needle Pressure Adjustment (See Figure 1)-

The needle pressure for playing microgroove records must not exceed 10 grams and it is strongly recommended that an occasional check be made with a stylus pressure gauge obtainable from your dealer. To adjust the stylus pressure turn the screw (1), at the rear of the pickup arm, Figure (1), clockwise to reduce pressure and counter-clockwise to increase it.

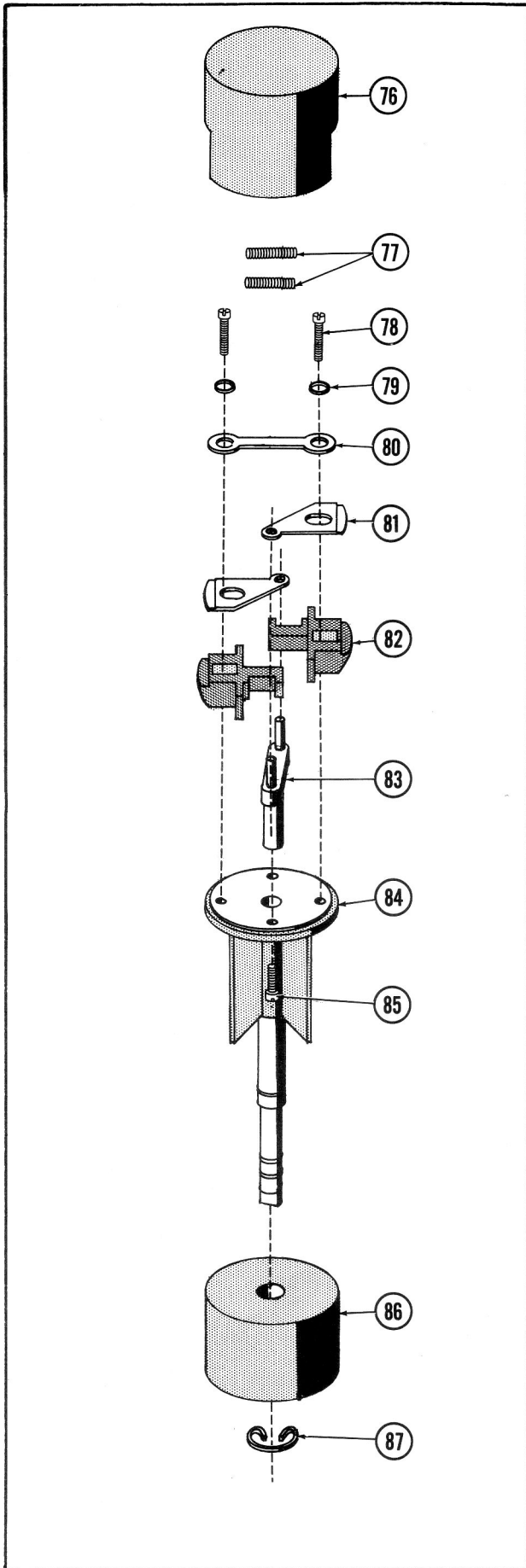

Figure 4. 45 RPM Spindle.

### Record Dropping Adjustment-

If the changer fails to drop records other than the 45 RPM type having a large centre hole, first make sure that the records are not badly warped. If they are reasonably flat, the record pushing pawl setting should be checked and adjustments made if necessary. To adjust the position of the record pushing pawl, the eccentric pin accessible under the unit plate (See Figure 2) should be turned with a screwdriver. Also check the record spindle by laying it on the template (Figure 9) to see that it is not bent out of position.

Should record fail to drop correctly when using the large diameter record spindle type LRS. 3, replace this spindle with the sloping one and see that it leans towards the record platform and is directly in line with it. If this spindle is out of position, it should be set correctly by loosening the two screws located on front of main spindle housing (52). Turn the record spindle until it is in line with the centre of the record platform and retighten the screws.

### Velocity Trip Adjustment-

The auto trip mechanism is the velocity type, that is it operates by the quick inward movements of the pickup arm when the pickup reaches the run off groove at the end of the record. The auto trip is of a special design to be very light and sensitive in operation and is set to commence operation when the stylus reaches a  $2 \frac{7}{8}$ " radius from the centre. If the auto trip (16) fails to operate the pickup will remain running in the centre of the record and to correct this remove the turntable (15) and raise the auto trip operating lever (16) by giving the "adjusting screw (19) for height of auto trip operating lever," (See Figure 1), about half a turn in a clockwise direction. This will raise the auto-trip operating lever (16) and enable it to engage the cam on the striker when the pickup runs into the record run-off groove.

### Cartridge Muting Switch-

A cartridge muting switch (40) is connected across the pick-up cartridge to short circuit the pick-up except when the changer is in the playing position. It is important to note that no sound will be obtained from the pick-up by flicking the needle when the pick-up is on its rest. The muting switch contacts should be closed except when the changer is in its playing position. Should this switch fail to operate, clean the contact faces, and insure that they make and break according to the position of the changer mechanism.

## TROUBLES

### Changer Fails To Reject Or Trip-

1. Check velocity trip as described under "Velocity Trip Adjustment".
2. Friction plate (18) binding preventing trip operating lever (16) from moving inward.

### Speed Variation-

1. It is essential that driving surfaces of brass motor pulley, rubber inter wheel, and turntable drum

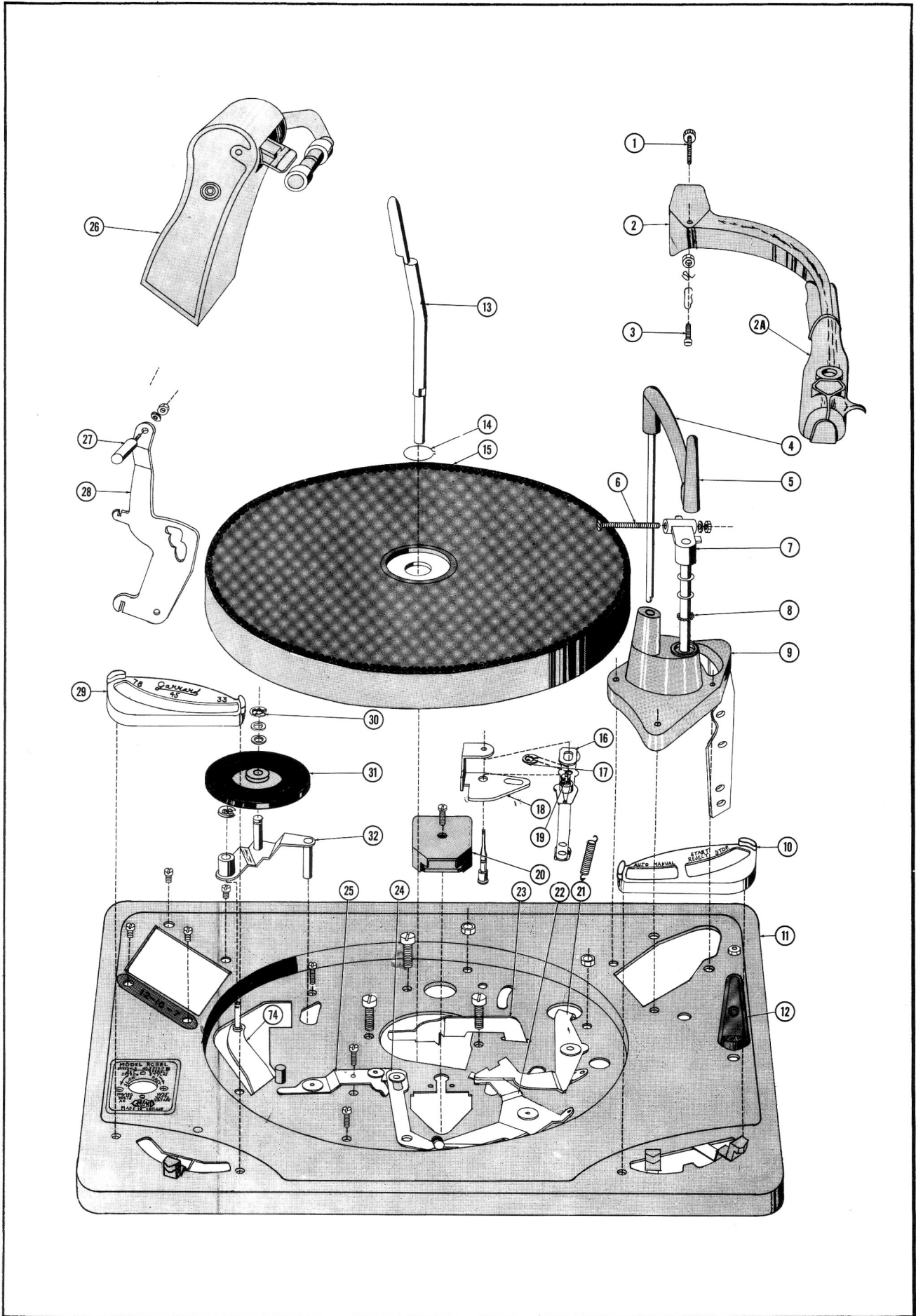

Figure 5A. Exploded View Of Parts Above Baseplate.

**GARRARD  
MODELS RC88, RC98**

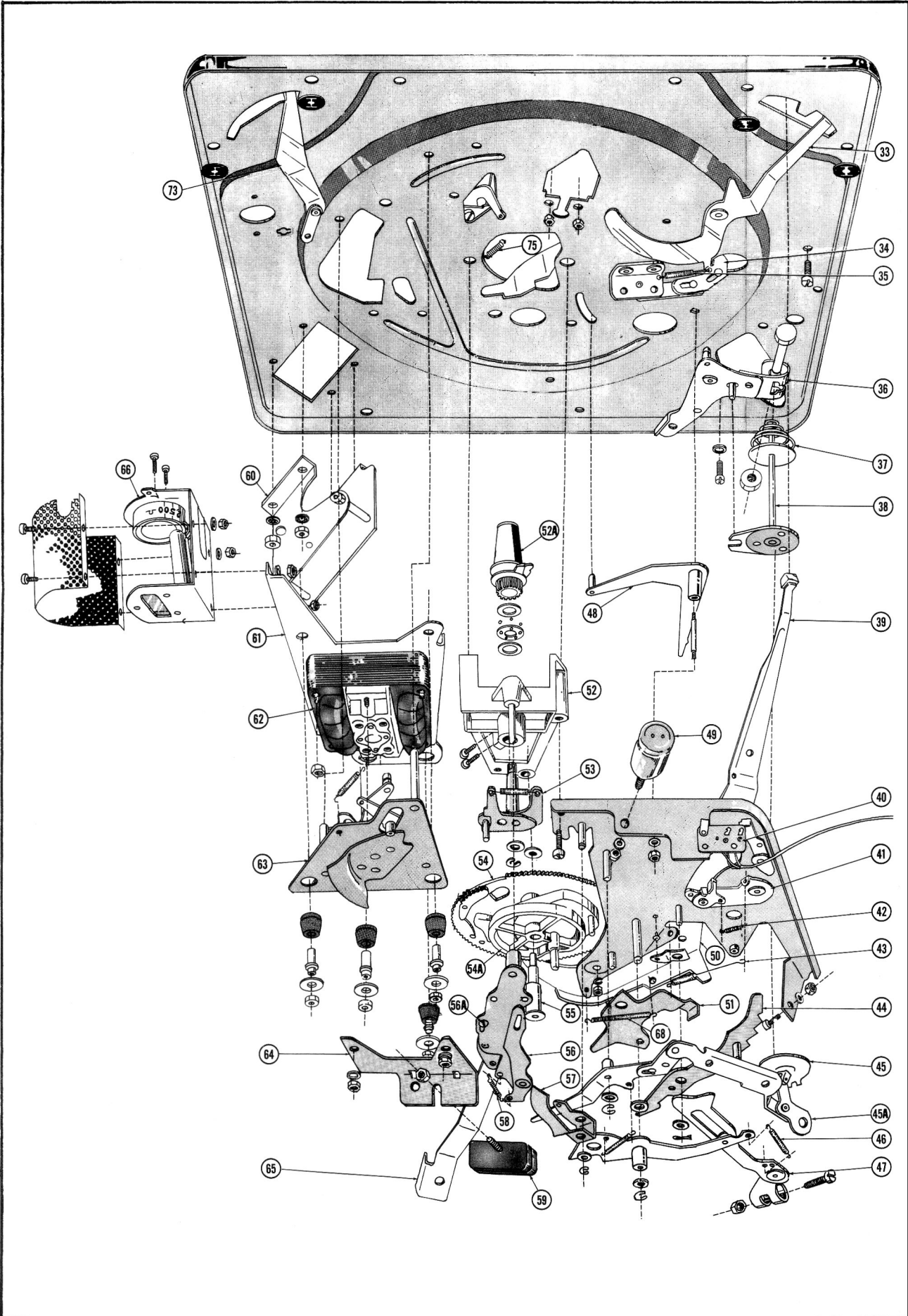

Figure 5B. Exploded View Of Parts Below Baseplate.

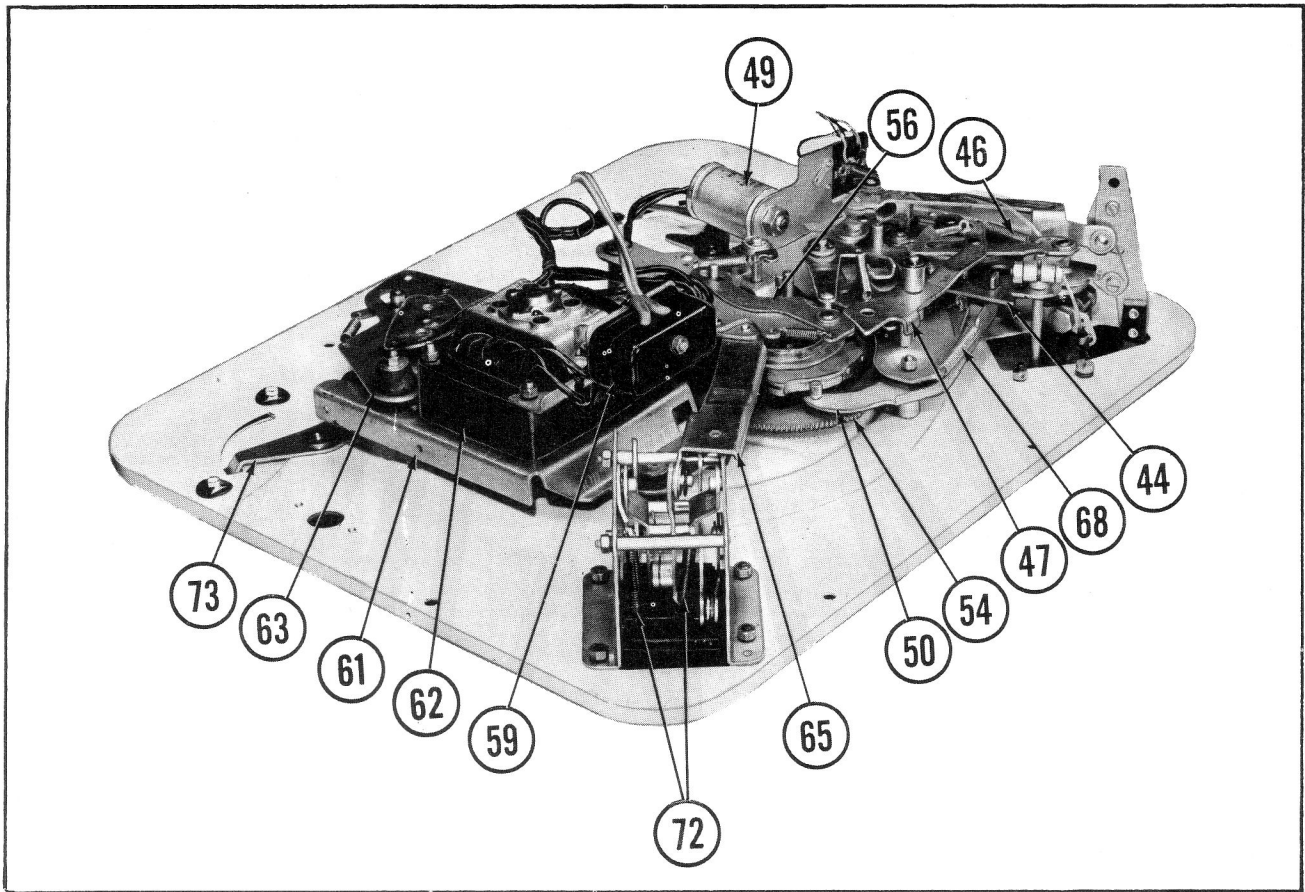

Figure 6

be kept absolutely free from oil or grease. This is the first point which should be checked if the turntable speed varies. The pulley and idlers should be cleaned with a dry cloth if these parts have been subjected to oil or grease.

2. Also check that the motor pulley is in its correct position on the motor shaft; switch the changer on and see that the inter wheel runs in the centre of the pulley and does not foul the side of the adjacent step. If necessary loosen the screws holding pulley to shaft and move pulley to its correct position.

3. See that the turntable spindle (52A) has a small amount of end play. To check this, with the turntable removed grip the turntable spindle (52A) firmly, lifting it up and down. If no movement is felt, loosen the screws which hold the fixed portion of the turntable spindle (52A), raise the turntable spindle a very small amount and retighten the screws. There should be approximately .005" end play.

4. If a thick oil has been used to lubricate the motor bearings, the motor will appear weak or will not start. It will then be necessary to dismantle the motor and clean away all traces of the thick oil. It is therefore, essential to lubricate the motor bearings with a good quality thin oil.

Needle Does Not Track Across Record Properly-

1. Needle may be clogged by accumulation of lint, dirt, etc.
2. Check condition of needle tip.

3. Check tone arm weight as described under "Needle Pressure".

4. Check tone arm pivot points for freedom of movement.

5. See that the changer is floating freely on its suspension springs, otherwise, the slightest vibration can cause the needle to skip across grooves.

6. Check the pick-up lead to see that it has enough slack to allow the needle to fully seat in the record grooves.

Turntable Does Not Revolve When Control Is Moved To "Start"-

1. No current at motor.
  - (a) Check that current is reaching terminal block.
  - (b) Check that switch (20) is operating properly.
  - (c) Check wiring and terminal connections in changer.
2. Motor defective.
  - (a) Remove turntable and allow motor to operate without load. If current is reaching motor and drive shaft does not rotate, the motor is defective. Repair or replace.
3. Inter wheel (31) not contacting motor shaft.



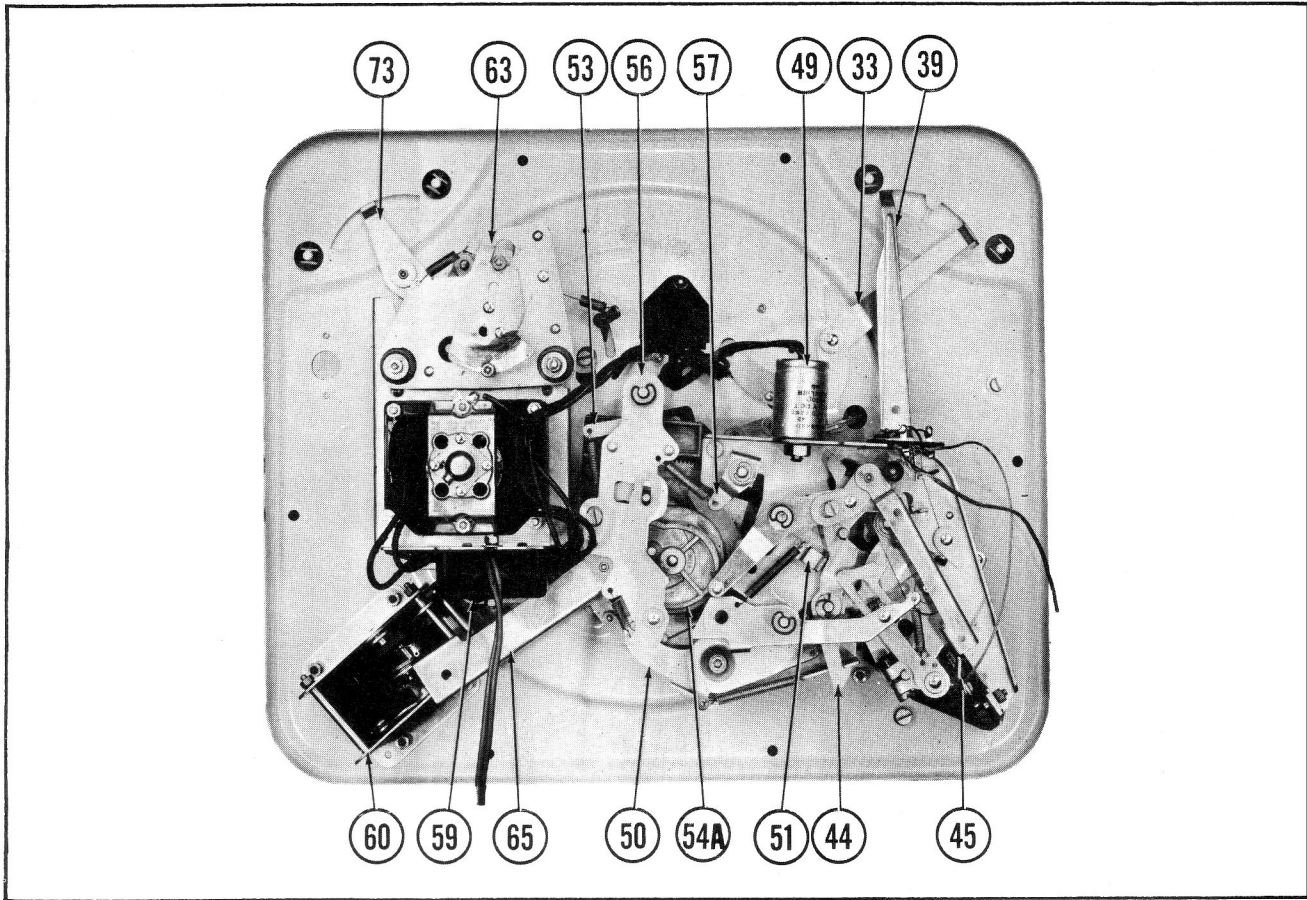

Figure 7. Bottom View Of Model RC-88.

GARRARD  
MODELS RC88, RC98

(a) Check that spring (75) is not loose or missing.

Tone Arm Strikes Records On Spindle During Cycle-

1. Tone arm height not adjusted properly.

(a) See instructions for adjusting tone arm height under "Adjustments".

Noise During Playing Of Record-

1. Motor rumble.

(a) If a low pitched rumbling sound comes from the loudspeaker while a record is being played, check motor grommets to be sure the motor is freely suspended on them. The motor leads should have slack to allow the motor to float. Motor rumble may also come from an unbalanced motor rotor; in this case replace motor.

2. Defective turntable bearings.

(a) Defective turntable bearings can cause rumble. Check for foreign matter in the bearings, defective balls, binding between balls and ball retainer; rough surface on washers. Clean bearing assembly and lubricate with light mineral oil.

3. Defective drive wheel tire (31).

(a) A rapid thumping sound while the motor is running may indicate a flat spot on the drive wheel tire. If this condition does not clear up after a few

minutes of running time, remove the turntable and inspect the rubber tires. If the tire surface is not even and smooth, replace the part. Should the bearing of the part show signs of excessive wear or be extremely wobbly, the defective drive wheel should be replaced.

4. Defective record.

(a) Worn or defective records cause needle scratch and distortion of the recorded sound. If a record is warped, it may slip on the other record causing "Wow" (a waver in the recorded sound). A chipped or enlarge centre hole in a record can also cause "Wow".

5. Defective needle.

(a) A defective needle will cause an excessive scratchy sound and will greatly reduce record life. Do not permit the use of a needle to its complete limit of wear. Best results are obtained by installing a new stylus periodically before defective reproduction becomes apparent.

**LUBRICATION**

The motor and drive wheel bearings are of the oilite type and rarely need lubricating. When the need for oil is apparent use a good grade of light machine oil.

**CAUTION:** Apply only one or two drops of oil on each bearing surface. Carefully remove every trace of surface oil before operating the changer.

Occasionally especially if the changer mechanism becomes rather noisy, put a smear of grease such as

Lubriplate on all cam faces, and lightly lubricate all lever pivots.

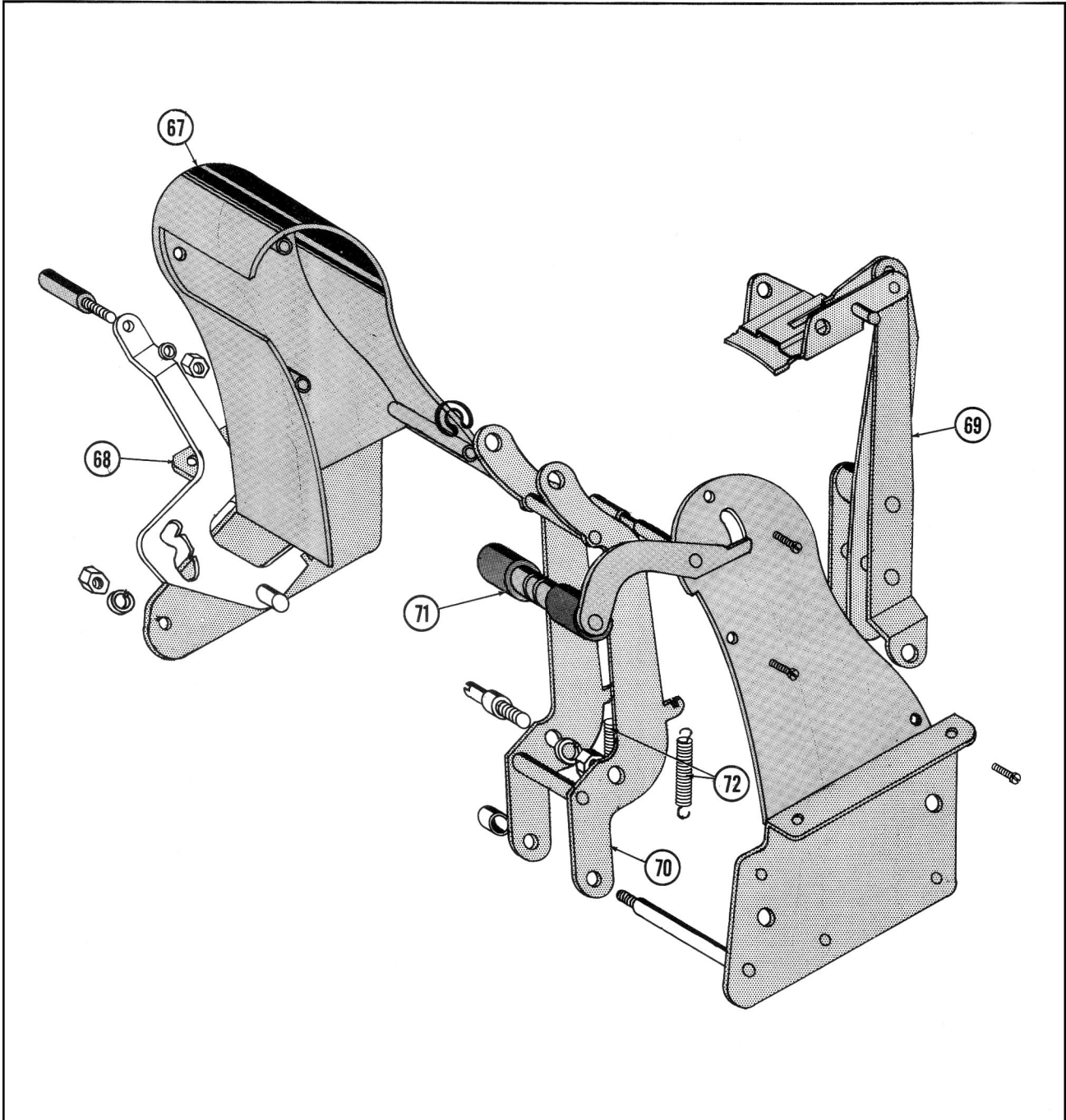

Figure 8. Record Platform Assembly

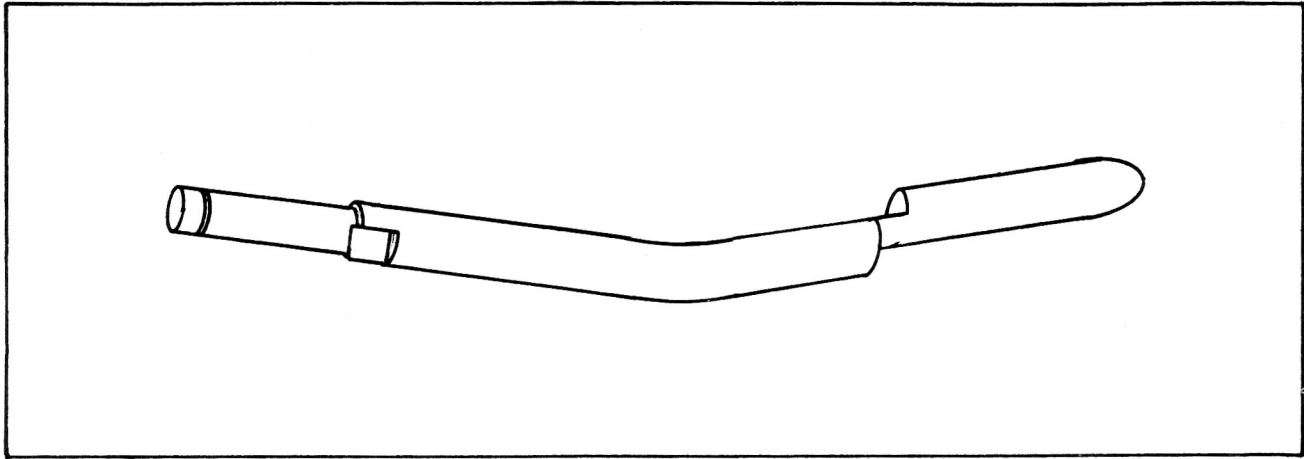

Figure 9. Template For Record Spindle.

MECHANICAL PARTS LIST

Ref. No.	Part No.	Description	Ref. No.	Part No.	Description
1		Stylus Pressure Adjusting Screw	39		Auto-Manual Lever
2	B. 52900	Pickup Arm	40		Muting Switch
2A	A. 52226	Plug-in Pickup Case Assembly	41		Index Lever
3		Pickup Height Adjustment Screw	42		Index Lever Spring
4		Size Selector & Switch Off Arm	43		Spring
5		Plastic Extension Cap	44		Pickup Locator Lever
6		Arm Mounting Screw	45		Pickup Crank Lift Assy.
7		Pickup Arm Mounting Bracket	46		Spring
8		Ball Bearings	47		Shut-Off Cam Lever
9		Pickup Arm Mounting Base	48		Auto Trip Actuating Lever
10		Start-Stop Escutcheon	49		Switch Click Suppressor
11		Baseplate Assembly	50		Pickup Actuating Lever
12		Pickup Arm Rest	51		Pickup Locator Push Lever
13	B. 52764	Record Spindle	52		Main Spindle Housing
14		Turntable Retainer	52A		Main Spindle
15	C. 52406	Turntable	53		45 RPM Actuating Lever
16		Auto Trip Operating Lever	54		Cycling Gear
17		"C" Retainer	54A		Cycling Cam
18		Friction Plate	55		Cycling Cam Shaft
19		Auto Trip Operating Adjustment Screw	56		Record Pushing Pawl Actuator
20		Switch Assembly	57		Cycling Gear Tension Lever
21		Catch Lever	58		Spring
22		Switch Lever	59		Power Supply Connecting Block
23		Stop Lever	60		Mounting Bracket, Record Platform Assembly
24		Lever (Part of Item 22)	61		Motor Mounting Plate
25		Tension Lever (Part of Item 22)	62		Motor
26		Record Platform Assembly	63		Speed Shifting Assembly
27		Change Over Lever Knob	64		Power Supply Connecting Block Mounting Bracket
28		Change Over Lever, Record Size	65		Coupling Link
29		Speed Change Escutcheon	66		Speed Adjusting Control
30		"C" Retainer	67		Record Platform Cover
31	B. 52567	Inter Wheel	68		Mounting Bracket & Change-Over Lever
32		Inter Wheel Mounting Bracket	69		Push-Off Lever Assembly
33		Start-Stop-Reject Lever	70		Positioning Lever Assembly
34		Stop Actuating Lever	71		Record Hold-Down Arm
35		Stop Lever Tension Spring	72		Spring, Positioning Lever
36		Pickup Lever	73		Speed Change Lever
37		Pickup Compression Spring	74		Support Lever
38		Pickup Lift Plate & Spindle	75		Spring

GARRARD  
MODELS RC88, RC98