

ENGINEERING DATA

STROMBERG-CARLSON NO. 520 RADIO RECEIVERS

STROMBERG-CARLSON TELEPHONE MANUFACTURING COMPANY
ROCHESTER, NEW YORK

IDENTIFICATION TABLE

Model	Input Power Frequency	Chassis	Cabinet	Speaker	Phonograph Equipment
520-H	50-60 Cycles	32832	32306	26171	Use No. 16 Record Player
520-HB	25-60 Cycles	32833	32306	26171	Use No. 16 Record Player
520-J	50-60 Cycles	32832	32098	26171	Use No. 16 Record Player
520-JB	25-60 Cycles	32833	32098	26171	Use No. 16 Record Player
520-L	50-60 Cycles	32043	32099	32166	Use No. 16 Record Player
520-LB	25-60 Cycles	32044	32099	32166	Use No. 16 Record Player
520-PF	60 Cycle	32178	32101	32166	32286
520-PFB	25 Cycle	32179	32101	32166	32287
520-PL	60 Cycle	32176	32102	32166	32283
520-PLB	25 Cycle	32177	32102	32166	32284
520-PG	60 Cycle	32986	32988	32989	32822
520-PGB	25 Cycle	32987	32988	32989	32823

SPECIFICATIONS

Type of Circuit	Superheterodyne
Tuning Ranges	A—540 to 1600 Kc., C—5700 to 18000 Kc.
Voltage Rating	A.C. 105 to 125 Volts
Number and Type of Tubes—7	
1—6SK7 R. F. Amplifier	1—6V6GT Output
1—6SA7 Modulator and Oscillator	1—6U5 Tuning Indicator
1—6SK7 I. F. Amplifier	1—5Y3G Rectifier
1—6SQ7 Demodulator, A. V. C., and Audio Amplifier	
Input Power Rating, 520-H, J, and L	78 Watts
Input Power Rating, 520-PF	95 Watts
Input Power Rating, 520-PL, and PG	110 Watts
Intermediate Frequency	455 Kilocycles
Speaker Voice Coil Impedance at 400 Cycles	Approximately 1.5 Ohm
Speaker Field Coil Resistance	Approximately 1050 Ohms

FEATURES

GENERAL. This is a seven tube, two gang, two range receiver with the 1600 kc. to 1700 kc. police band included in the broadcast range. The dial is edge-lighted to provide clear visibility without glare. Iron core coils are used in the low frequency of each range so that greater accuracy of alignment can be obtained. A compensator circuit is provided in the broadcast range to prevent oscillator drift.

Eight button automatic tuning is provided so that six favorite stations may be set up; the other two buttons are for switching to "Phonograph" or "Radio".

Tone is adjusted on the 520-H, J, and L by a step tone control, which regulates both bass and high frequency response. Separate bass and treble controls are provided on the phonograph models.

Provision is made for a record player to be used with all models not already equipped with phonograph mechanism without additional wiring. The Nos. 520-PF, PL, and PG phonograph models are equipped with an automatic record changer using a crystal pick-up in conjunction with a specially equalized circuit. The record player shifts and plays either 10 or 12 inch records.

ANTENNA. The built-in loop antenna provided in these receivers will give satisfactory operation in most locations. However, antenna and ground terminals are provided on the chassis and for improved reception, a Stromberg-Carlson All-Wave Antenna is recommended. These antennas are supplied in kits containing all the necessary parts for mounting and installation, and are designed especially for use with all Stromberg-Carlson receivers.

A Loop antenna is provided in these receivers so that no antenna and ground connections whatsoever are required. However, antenna and ground terminals are provided on the chassis, so that an external antenna may be used for improved reception if it is desired.

AUTOMATIC TUNING. Eight button mechanical automatic tuning is provided, so that six favorite stations may be set up. The other two buttons are for switching to phonograph or radio.

PHONOGRAPH OPERATION. A jack is provided on the back of the chassis of all receivers not already equipped with phonograph mechanism, into which a record player may be plugged, and a push button is provided on the front of the receiver for switching from "Radio" to "Phonograph".

TELEVISION. A foil is provided on the back of the chassis into which a television receiver may be plugged. Switching to phonograph makes the audio amplifier and loud speaker available for use with television receivers designed for this type of sound reproduction.

ACCESSORIES

PLAYING RECORDS (520-H, J, AND L RECEIVERS). For receivers not already equipped with phonograph mechanism, a Stromberg-Carlson record player is recommended. They are designed for use with this receiver, and all that is necessary is to connect the record player to the single prong socket provided in the chassis, push in the phono button and proceed to operate. The volume and tone may be controlled with the

controls at the receiver or (if such is provided) the volume control on the record player may be used.

HEADSET ATTACHMENT. Headphones can be very simply attached to this receiver. Ask for Pc. 28303 Headset Package Assembly, which comes complete with headphones and installation instructions.

CARE OF THE CABINET. The finish of Stromberg-Carlson cabinets should be protected by using Stromberg-Carlson cabinet polish regularly. It is available in pint cans designated as Pc. 28601.

Nicks and scratches of most kinds can be repaired quickly and easily by proper use of the Pc. 26962 Touch-Up Kit. Complete instructions are provided with each kit.

ADJUSTING THE DIAL LAMP. To obtain the proper illumination of the dial, slide the two dial lamp sockets on their mounting brackets to the position where maximum illumination of the dial is obtained.

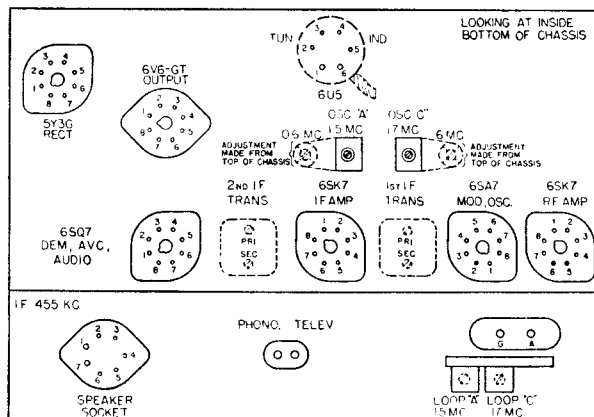

Location Chart

ALIGNING INFORMATION

Never re-align unless absolutely necessary.

Use a good modulated signal generator (test oscillator with variable output voltage and a sensitive output meter across the voice coil of the speaker.)

Always align using the smallest possible input from the signal generator. A strong signal makes adjustments inaccurate.

Always have the volume control "full on".

ALIGNING PROCEDURE. (Follow this order exactly.)

I. Dial pointer adjustment.

With the plates of the gang tuning capacitor fully engaged, check to be sure that the dial pointer is in a vertical position directly on the calibration marks located at the low frequency end of the dial scale. Adjust if necessary.

II. Intermediate frequency adjustments.

1. Set range switch to Standard Broadcast position.
2. Turn set to extreme low frequency end of dial.
3. Connect the ground terminal of the signal generator to the ground terminal of the chassis.
4. Introduce a modulated signal of 455 kilocycles to the grid of the 6SA7 Modulator and Oscillator tube (terminal No. 8) using a 0.1 microfarad capacitor in series with the output lead of the signal generator.
5. Adjust the I. F. aligners for maximum output in the following order:
 - A. Secondary of second I. F. Transformer.
 - B. Primary of second I. F. Transformer.
 - C. Secondary of first I. F. Transformer.
 - D. Primary of first I. F. Transformer.

III. Radio frequency adjustments.

Short Wave Range (C Band).

1. Remove the output lead of the signal gen-

erator and the 0.1 microfarad capacitor from the grid of the 6SA7 tube.

2. Disconnect the output lead from the signal generator and replace with a few turns of wire connected to the signal generator output terminals.
3. Place the signal generator two or three feet from the receiver's loop.
4. Set the range switch to the short-wave range position (C Band).
5. Set the signal generator frequency and the receiver tuning dial to 0.6 megacycles.
6. Adjust the 0.6 megacycle iron core for maximum signal.
7. Adjust the spacing of the short-wave loop leads for maximum signal.
8. Set the signal generator frequency and the receiver tuning dial to 17 megacycles.
9. Adjust the oscillator and loop aligning capacitors for maximum signal.
10. Repeat operations 5, 6, and 7.
11. Repeat operations 8 and 9.

Standard Broadcast Range (A Band).

1. Set the range switch to the "Loop" position.
2. Set the signal generator frequency and the receiver tuning dial to 600 kilocycles.
3. Adjust the 600 K. C. oscillator iron core for maximum signal.
4. Set the signal generator frequency and the receiver tuning dial to 1500 kilocycles.
5. Adjust the 1500 K. C. oscillator and loop aligning capacitors for maximum signal.
7. Repeat operations 2 and 3.
8. Repeat operations 4 and 5.

IV. Wave Trap Adjustment (520 Table Models only).

1. Tune the receiver to 1000 kc.
2. Set the signal generator frequency to 455 kc., and introduce a fairly strong modulated signal to the receiver.
3. Adjust the wave trap aligning capacitor for minimum signal.

NORMAL VOLTAGE READINGS

Take all readings with chassis operating and tuned manually to 1000 kc.—No signal.
 Use a line voltage of 120 volts or make allowance for the variations.
 Use a good high resistance voltmeter having a resistance of at least 1000 ohms per volt.

Take all D.C. readings on the 500 volt scale except when an asterisk appears.
 Read from indicated terminals to chassis base.
 See location chart on page 2 for position of terminals. A.C. voltages are indicated by italics.

		TERMINALS OF SOCKETS							
Tube	Circuit	1	2	3	4	5	6	7	8
6SK7	R. F. Amplifier	0	0	0	0	+3*	+115	<i>6.3</i>	+200
6SA7	Modulator and Oscillator	0	0	+250	+115	0	0	<i>6.3</i>	0
6SK7	I. F. Amplifier	0	0	0	0	+2	+100	<i>6.3</i>	+250
6SQ7	Demodulator, A. V. C., Audio	0	0	0	0	0	+95	<i>6.3</i>	0
6V6GT	Output	0	0	+300	+250	0	0	<i>6.3</i>	+12*
6U5	Tuning Indicator	<i>6.3</i>	+90	0	+250	0	0	—	—
5Y3G	Rectifier	0	+400	0	<i>385</i>	0	<i>385</i>	0	+400
Speaker Socket	—	+310	0	0	+400	+400	0	+400	—

*Read on lowest possible scale of voltmeter

CONTINUITY TEST

CAUTION: Remove all tubes and disconnect the receiver from the power supply before making continuity test.

Test speaker socket with speaker left out. Plug speaker in socket for all other tests.

Use a good meter capable of measuring accurately up to several megohms.

The resistances given are often approximate, owing to the electrolytic capacitors in the circuit. When this is the case, be sure to reverse the test leads and read the highest resistance.

Read from indicated terminals to chassis base unless otherwise specified.

See location chart on page 2 for position and numbering of terminals.

		TERMINALS OF SOCKETS							
Tube	Circuit	1	2	3	4	5	6	7	8
6SK7	R. F. Amp.	S	S	S	A	B	20000 Ω	S	7300 Ω
6SA7	Mod. and Osc.	S	S	2200 Ω	20000 Ω	33000 Ω	C	S	47000 Ω
6SK7	I. F. Amp.	S	S	S	D	220 Ω	85000 Ω	S	2200 Ω
6SQ7	Demod., A. V. C., Audio Amp.	S	10M	S	E	S	F	S	S
6V6GT	Output	S	S	200 Ω	2200 Ω	470000 Ω	S	S	240 Ω
6U5	Tuning Indicator	S	100000 Ω	G	2200 Ω	S	S		
5Y3G	Rectifier	O	O	O	130 Ω	O	140 Ω	O	O
Loop	3 Prong	O	O	S	—	—	—	—	—
Loop	4 Prong	O	S	2200 Ω	O	—	—	—	—

Symbols used on chart are as follows: Ω —ohms; M—megohms; S—short; O—open

- | | | | |
|---|--------------|--|--------------|
| A. Push "Radio" button in..... | 3.2 Megohms | Range switch in external antenna position | 240,000 Ohms |
| Push "Phono" button in | "Open" | Range switch in short-wave position | 270,000 Ohms |
| B. Range switch in Loop position... | 1700 Ohms | G. Push "Radio" button in..... | 3.3 Megohms |
| Range switch in external antenna position | 220 Ohms | Push "Phono" button in..... | 3.3 Megohms |
| Range switch in short-wave position | 220 Ohms | Other tests not shown on chart— | |
| C. Range switch in Loop position... | 5 Ohms | Test from phono jack on back of chassis base: | |
| Range switch in external antenna position | 5 Ohms | Push "Radio" button in..... | "Open" |
| Range switch in short-wave position | "Short" | Push "Phono" button in..... | 1 Megohm |
| D. Push "Radio" button in..... | 3.2 Megohms | Test from Television jack on back of chassis base: | |
| Push "Phono" button in..... | "Open" | Push "Radio" button in..... | "Open" |
| E. Push "Radio" button in..... | 1 Megohm | Push "Phono" button in..... | 1 Megohm |
| Push "Phono" button in..... | "Open" | Test between terminals of A.C. plug: | |
| F. Range switch in Loop position... | 240,000 Ohms | "Off-On" switch in "Off" position | "Open" |
| | | "Off-On" switch in "On" position | 5 Ohms |
| | | Terminals of A.C. plug to chassis base | "Open" |

INSTRUCTIONS FOR SETTING UP PUSH BUTTONS

IMPORTANT: The stations selected should be the local or favorite stations which give good reception at all times.

Set up stations in the daytime to avoid unnecessary interference.

Allow the set to run for about twenty minutes before setting up stations.

Always use the tuning indicator unit when setting up stations, in order to determine when the station is exactly in tune.

1. Turn the receiver "On".
2. Push in the "Radio" button.
3. Set the Range Switch as follows:
 - a. If an external antenna is used, set knob so arrow points to designation "ANT."
 - b. If the built-in loop antenna is used, set knob so arrow points to designation "Loop".
4. Turn volume control about three-quarters of the way on (in a clockwise direction).
5. Pull the six station push buttons off their levers.
6. Remove the call letters of the six selected stations from the call letter sheets, which are in an en-

velope stapled to the cabinet. Insert the station call letters part way in the slots at the sides of the buttons. Next, insert a transparent tab in each slot in front of the station letters. Then push both the transparent tabs and the call letters all the way into the slot. A pencil eraser may be helpful.

7. Loosen the set screw of the lever to be set up.
8. Push in the lever and manually tune in the desired station, observing the tuning indicator in order to obtain exact resonance.

IMPORTANT: For accurate set-up, be sure that the lever is pushed in, in the same manner and with the same amount of pressure as will be used when operating the push buttons.
9. Tighten the set screw. Be sure not to disturb the adjustment in any way while tightening the screw.
10. Place the proper button on the lever.
11. Check the accuracy of the adjustment by detuning the station and retuning with the button several times, pushing the button with an even pressure. Readjust if necessary.
12. Set up the other five stations in the same manner.

REPLACEMENT PARTS

Capacitors

Piece No.	Circuit Designation	Part
24314	C-27	10 mmf. Capacitor
24559	C-29, 30 (C-26—520-L)	100 mmf. Capacitor
27108	C-21, 22	Dual .05 mf. Capacitor
27305	C-28	50 mmf. Capacitor
27538	C-8005 mf. Capacitor
27801	C-31 (C-26—520-PL and PF)	200 mmf. Capacitor
29284	C-34001 mf. Capacitor
29481	C-33002 mf. Capacitor
30322	C-23 (C-34—520-PF, PL) (C-25—520-PG)	.005 mf. Capacitor
31373	C-26 (520-PG)	400 mmf. Capacitor
31481	C-19, 20, 24, 32, 36 (C-25—520-H, J, L)01 mf. Capacitor
32052	C-1, 2, 3, 4	Electrolytic, 1—40 mf., 2—15 mf., 1—20mf.
32057	C-5	700 mmf. Capacitor
32058	C-9, 10	Aligner, 2 Unit
32067	C-17, 18	Variable Capacitor and Pulley

Coils, Transformers and Speakers

32050	L-1, 2, 3, 4, 5	Power Transformer, 50/60 Cycles (520-L, PL, PF, and PG)
32051	L-1, 2, 3, 4, 5	Power Transformer, 25/60 Cycles (520-L, PL, PF, and PG)
32891	L-1, 2, 3, 4, 5	Power Transformer, 50/60 Cycles (520-H, J)
32892	L-1, 2, 3, 4, 5	Power Transformer, 25/60 Cycles (520-H, J)
30124	L-24	Wave Trap (520-H, J only)
32053	L-6, 7; C-6	Oscillator Coil (Broadcast)
32054	L-8, 9; C-7	Oscillator Coil (Short Wave)
32060	L-10	R. F. Choke Coil
32061	L-11, 12; C-11, 12	1st I. F. Transformer
32062	L-13, 14; C-13, 14, 15, 16; R-1	2nd I. F. Transformer
32065	L-15, 16	Output Transformer
32181	Loop for Standard Broadcast
32202	Loop for Short Wave
26171	Speaker (520-H, J)
25492	Cone for P-26171 Speaker
32166	Speaker (520-L, PL and PF)
27808	Cone for P-32166 Speaker
32989	Speaker (520-PG)
27376	Cone for P-32989 Speaker

Controls and Knobs

Piece No.	Circuit Designation	Part
29560	R-2	Volume Control
32059	Range Switch
32063	R-3	Off-On Switch and Tone Control (520-H, J, L)
32064	Radio-Phono Switch
32259	R-32	Bass Control (520-PL, PF)
32821	R-33	Off-On Switch and Tone Control (520-PL, PF, PG)
32078	Dial Drive
32129	Dial Drive Cord
32145	Knob for Range and Tone Control (520-H, J, L, PL)
32146	Knob for Volume Control
32147	Knob for Tuning Dial
32224	Knob for Loop and Bass Control (520-L, PL, PF, PG)
32441	Knob for Range and Tone Control (520-PG, PF)
32156	Push Button
27628	Felt Washer for Knobs

Resistors

26325	R-13	220 Ohm Resistor
26329	R-21	470 Ohm Resistor
26335	R-23	1500 Ohm Resistor
26337	R-20	2200 Ohm Resistor
26341	R-16	4700 Ohm Resistor
26345	R-17	10,000 Ohm Resistor
26350	R-10 (R-25—520-L)	27,000 Ohm Resistor
26351	R-5, 35	33,000 Ohm Resistor
26352	R-31	39,000 Ohm Resistor (520-PF)
26353	R-9, 24, 27	47,000 Ohm Resistor
26355	R-29, 30 (520-H, J, PL, PF)	66,000 Ohm Resistor
26357	R-29 (520-PG)1 Megohm Resistor (520-PG)
26359	R-3115 Megohm Resistor (520-PG)
26362	R-12, (R-31—520-PG)27 Megohm Resistor
26365	R-1147 Megohm Resistor
26369	R-15	1 Megohm Resistor
26371	R-6	1.5 Megohm Resistor
26373	R-8	2.2 Megohm Resistor
26381	R-4	10 Megohm Resistor
29563	R-18, 19	39,000 Ohm Resistor
32096	R-22	240 Ohm Resistor
32256	R-34	82,000 Ohm Resistor
32940	R-26	2200 Ohm Resistor

Miscellaneous Parts

Piece No.	Circuit Designation	Part
26122		Antenna and Ground Terminals
27088		Spring Washer for Coil Mounting
28652		Power Supply Cord
28694		Pilot Lamp Socket Assembly
29379		Palnut for Control Shafts
29514		Palnut for Mounting I. F. Transformers
29956		Pilot Lamp
30151		8-Prong Socket
30152		7-Prong Socket
30224		Phono-Telv. Plug
31539		Phono-Telv. Jack
32046		3-Prong Socket
32047		4-Prong Socket
32048		A.C. Outlet Socket
32056	RC-1	Compensator
32075		Small Pulley for Drive Cord

Miscellaneous—Continued

Piece No.	Circuit Designation	Part
32077		Large Pulley for Drive Cord
32088		Dial Pointer Slide Bar
32090		Dial Pointer
32094		Dial Scale (520-H, J, L)
32095		Tuning Indicator Cable
32128		Drive Cord and Spring
32130		Drive Cord
32170		Station Call Letters (520-PL, H, J, L)
32172		Dial Lens
32173		Push Button Escutcheon
32197		Screw for Push Button Escutcheon
32280		Dial Scale (520-PG, PF, PL)
32225		Station Call Letters (520-PF, PG)
32298		Phono Pilot Lamp Socket
32443		Escutcheon Phono Pilot Lamp (520-PF, PG)

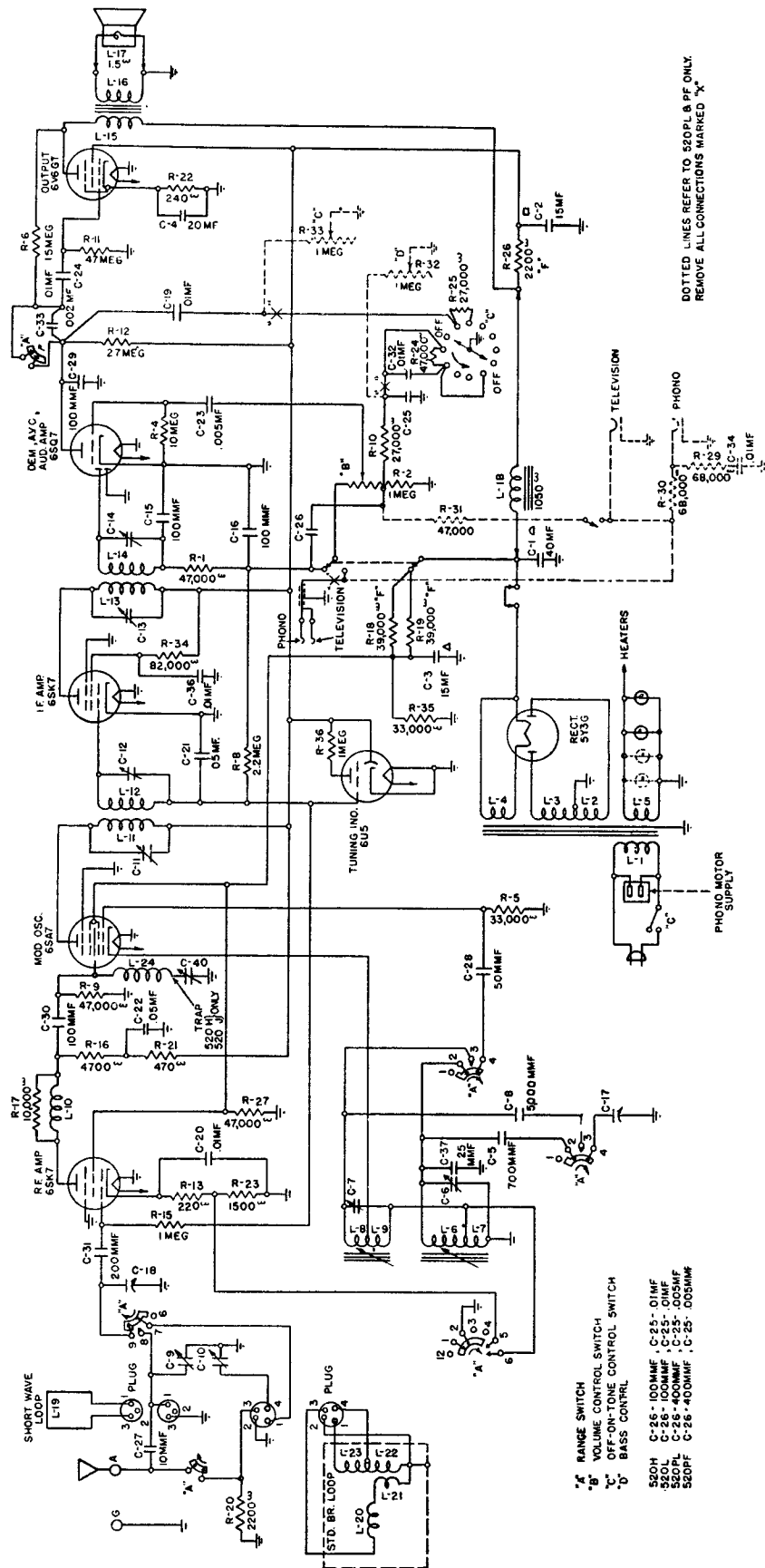

DOTTED LINES REFER TO 520PL & PF ONLY.
REMOVE ALL CONNECTIONS MARKED "X"

Schematic Circuit

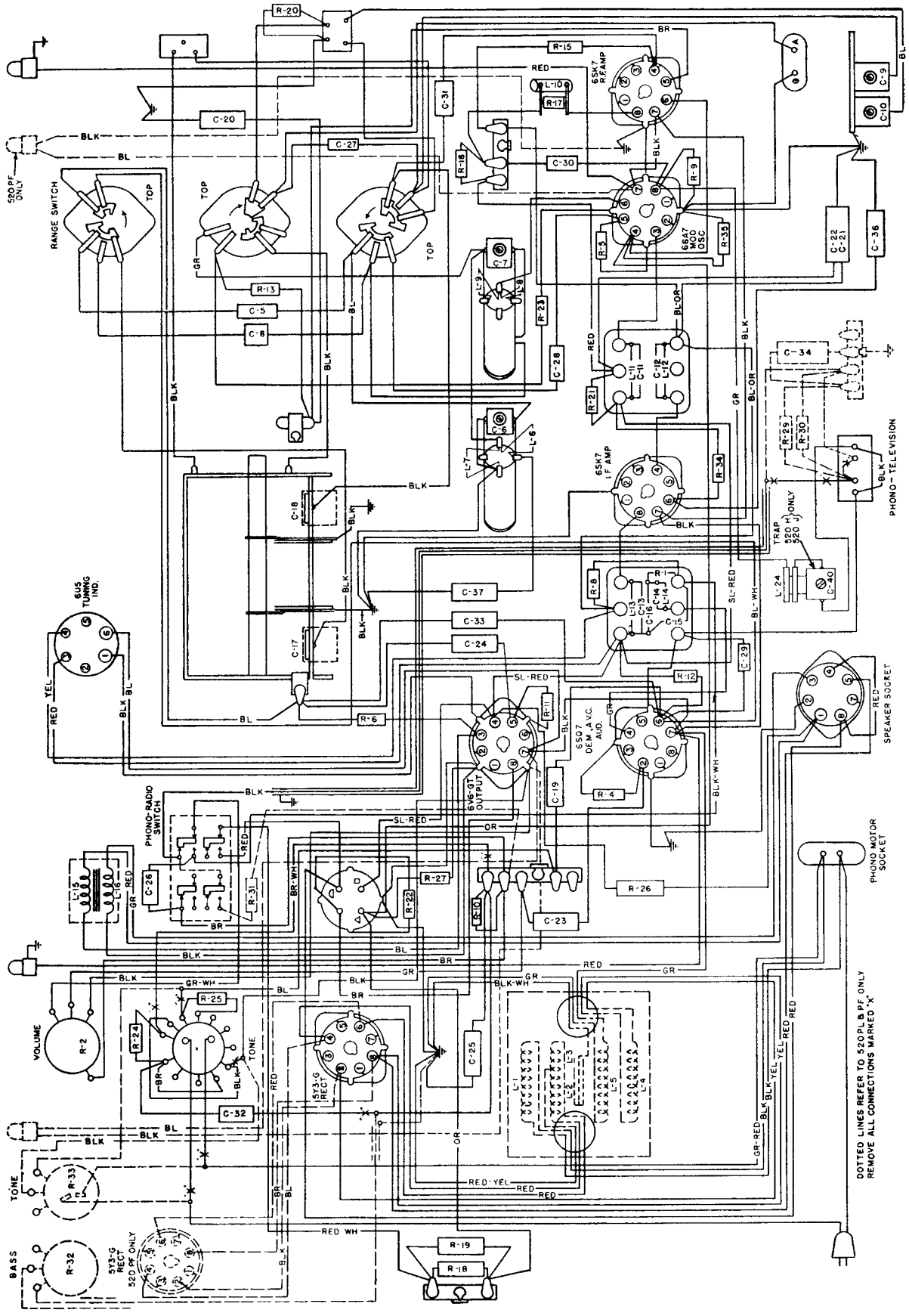

Wiring Diagram