

# JVC

No. 2333

# SERVICE MANUAL

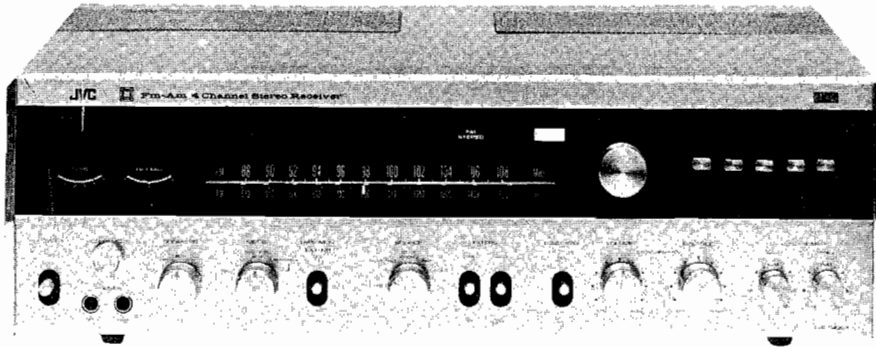

## MODEL 4VR-5436X

FM/AM 4CHANNEL STEREO RECEIVER  
WITH CD-4 DEMODULATOR

DIMENSIONS: H — 6-3/8" W — 20" D — 15-3/8" Weight : 31.5 lbs  
(16.4cm) (50.8cm) (39.1cm) (14.3 kg)

### SPECIFICATIONS

#### AMPLIFIER SECTION

RMS Power : 15W per channel at 8Ω  
All Channels Driven, 15W per channel at 4Ω  
20Hz~20kHz  
Power Bandwidth : 35W per channel at 8Ω (BTL)  
RMS Power : 68W (17W x 4) at 8Ω  
All Channels Driven, 72W (18W x 4) at 4Ω  
at 1kHz 74W (37W x 2) at 8Ω (BTL)  
Total Dynamic Power (IHF) : 110W (27.5W x 4) at 8Ω  
140W (35W x 4) at 4Ω  
IHF Power Bandwidth : 10Hz~25kHz  
Total Harmonic Distortion : 0.8% at rated output  
0.2% at half rated output  
Intermodulation Distortion : 1.0% at rated output  
0.2% at half rated output  
Load Impedance : 4Ω~16Ω (8Ω~16Ω; for BTL)  
Damping Factor : 30 at 8Ω  
Input Sensitivity, : Phono 1.5mV/100kΩ, 65dB  
Impedance and S/N Ratio : Aux-1, -2 200mV/50kΩ, 75dB  
Tape Mon. 200mV/50kΩ, 75dB  
Recording Output Level : 200mV  
Frequency Response : 20Hz~30kHz, ±1dB  
SEA Center Frequency : 40, 250, 1k, 5k, 15kHz  
(Front)

SEA Control Range (Front) : ±12dB  
Bass Control (Rear) : ±10dB at 100Hz  
Treble Control (Rear) : ±10dB at 10kHz  
Loudness Control : +12dB at 50Hz  
+6dB at 10kHz  
Low Cut Filter : -10dB at 50Hz  
High Cut Filter : -10dB at 10kHz  
Crosstalk : 50dB at 1kHz

#### FM TUNER SECTION

Tuning Range : 88MHz~108MHz  
Usable Sensitivity : 2.0μV (IHF)  
Total Harmonic Distortion :  
(at 400Hz, 100% Mod) MONO 0.5%  
STEREO 0.8%  
Signal to Noise Ratio : 65dB  
Selectivity : 65dB  
Capture Ratio : 2.0dB  
Muting Level : 10μV

#### MW TUNER SECTION

Tuning Range : 520kHz~1605kHz  
Usable Sensitivity : 30μV, 200μV/m  
Selectivity : 30dB

## REMOVAL OF THE TOP COVER AND BOTTOM PLATE

1. Remove 4 screws through the both sides of the top cover.
2. Remove the top cover
3. Remove screws from bottom plate and remove the bottom plate from the chassis.

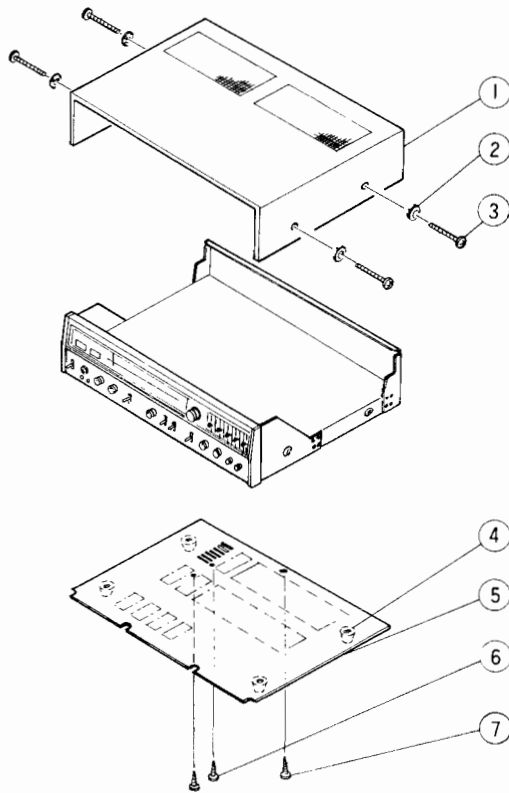

- |   |            |                   |
|---|------------|-------------------|
| ① | DL-ED92382 | Wooden Case       |
| ② | E48193-002 | Washer            |
| ③ | SDSP4012MS | Screw             |
| ④ | E48599-001 | Foot              |
| ⑤ | SDSB3012N  | Tapping Screw     |
| ⑥ | E1756-001  | Bottom Plate      |
| ⑦ | SDSB4008N  | Tapping Screw × 2 |
| ⑧ | SDSB3008N  | Tapping Screw × 9 |

Fig. 1

## FINAL PACKING ASS'Y

PARTS NAME	PARTS NO.
Envelope	E32332-017
Carton Case	4VR-5436X-PK
Packing Materials	4VR-5436X-NZ

**MAIN PARTS ARRANGEMENT**

TOP VIEW

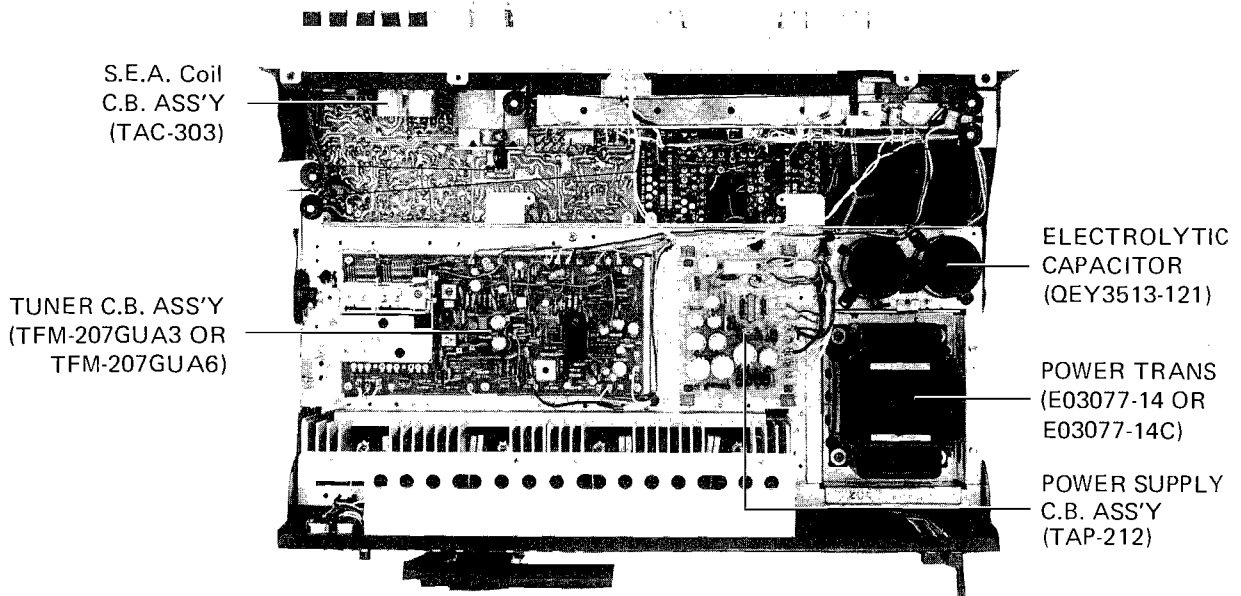

Fig. 2

BOTTOM VIEW

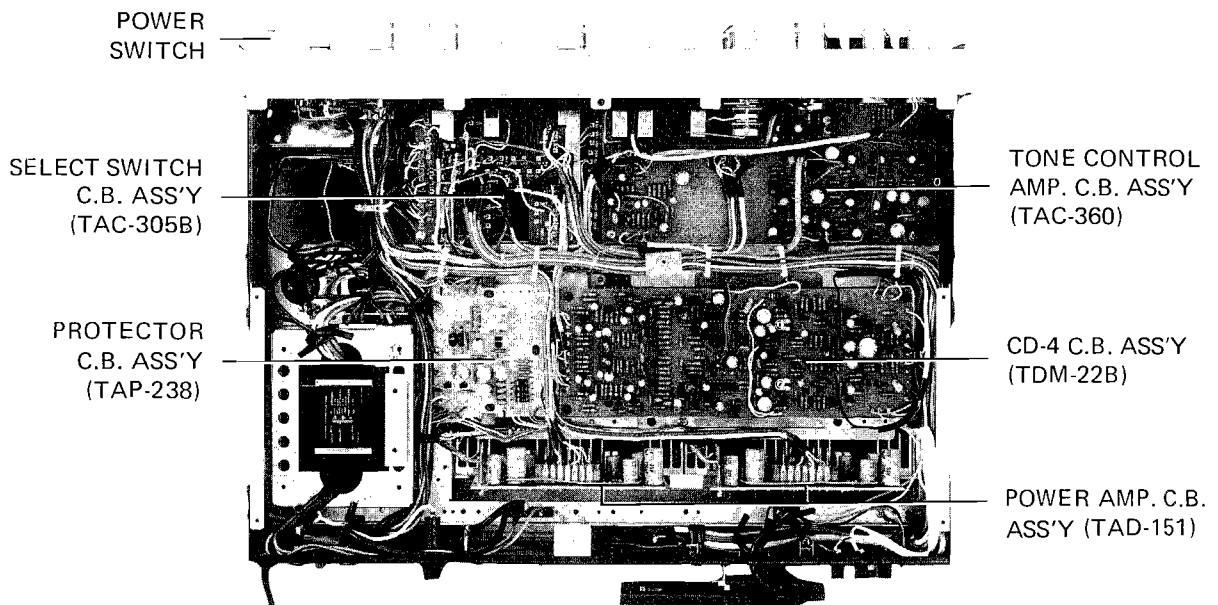
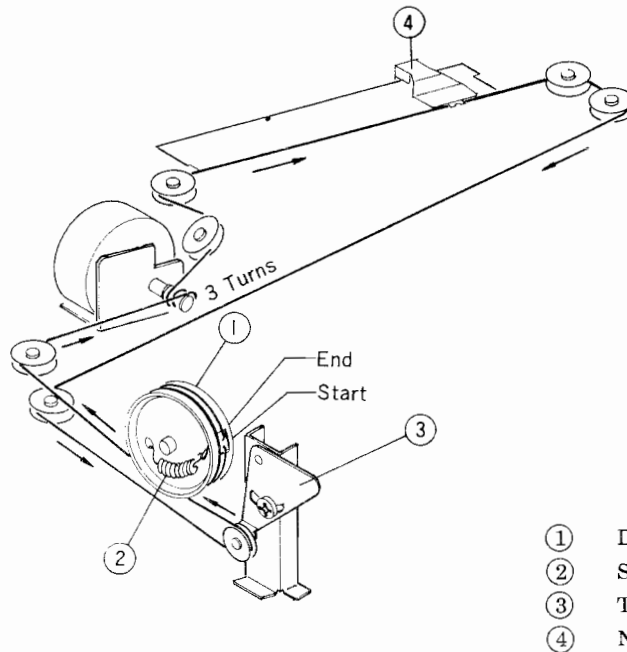

Fig. 3

## HOW TO FIT THE DIAL CORD

1. Set the variable capacitor on maximum capacity.
2. Be sure dial drum is firmly fixed to the shaft.
3. Fit the dial cord in accordance with arrow marks.
4. Wind the cord around the tuning shaft 3 turns and dial drum 3 turns.
5. Place the pointer on the rail and fix to the dial cord.



①	Dial drum	QZD1205-002
②	Spring	E45679-001
③	Tension control	E46061-001S
④	Needle pointer	E33502-001

Fig. 4

## POWER TRANSFORMER VOLTAGE & WIRE COLOR

### POWER TRANS VOLTAGE

E03077-14C

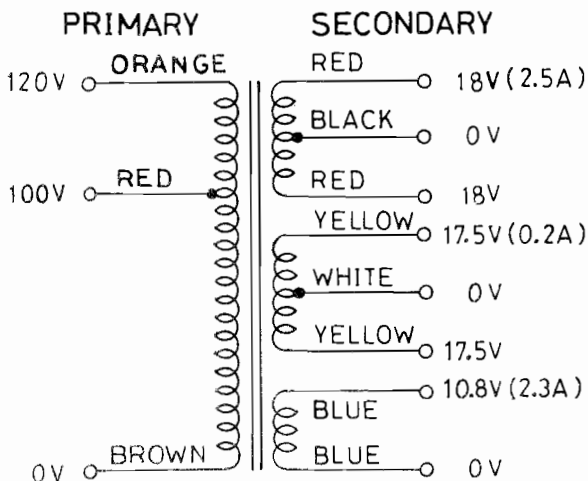

(FOR AMERICA AND CANADA)

### POWER TRANS VOLTAGE

E03077-14

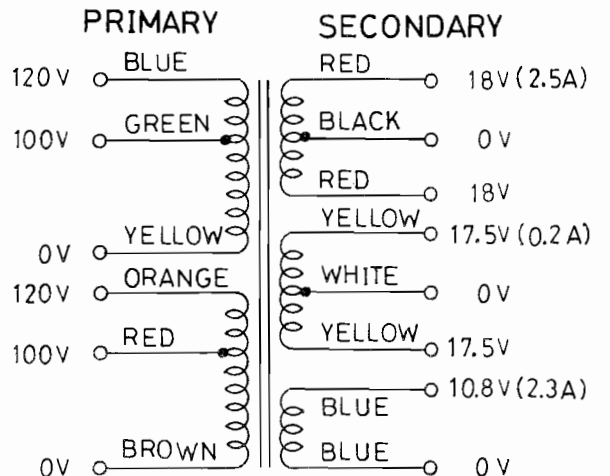

Fig. 5

## REMOVAL OF THE POWER AMPLIFIER CIRCUIT BOARD ASS'Y

1. Pull out the wire connector ass'y (Fig. ①, ②, ③, ④) from power amplifier circuit board.
2. Remove the 3 screws (Fig. ⑤, ⑥, ⑦) fixing the sub heat sink to the rear panel.
3. Remove the 4 screws (Fig. ⑧, ⑨, ⑩, ⑪).

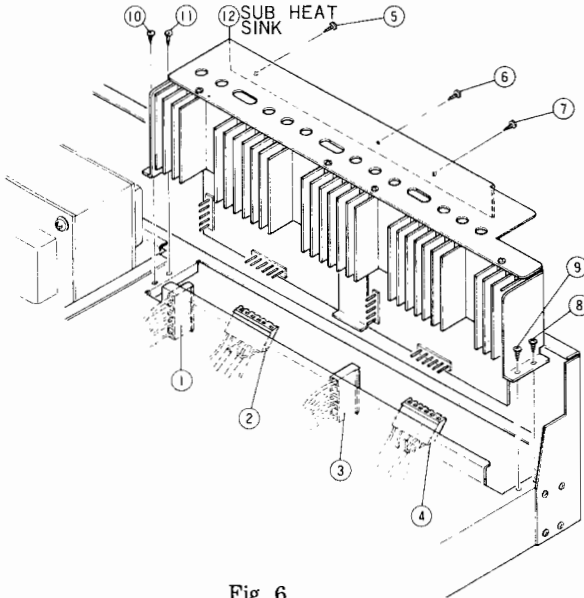

Fig. 6

①, ③	Pin Socket	E03565-5B
②, ④	"	E03565-7B
⑤, ⑥, ⑦	Tapping Screw	SDSB3008M
⑧, ⑨, ⑩, ⑪	"	SDSB3008N
⑫	Sub Heat Sink	E33513-001

## HOW TO REPAIR & CHECK THE TUNER CIRCUIT BOARD ASS'Y & CD-4 DEMODULATOR CIRCUIT BOARD ASS'Y

1. Remove the 2 screws (Fig. ①, ②).
2. Turn up the circuit board bracket with CD-4 demodulator circuit board ass'y. (Fig. ③)

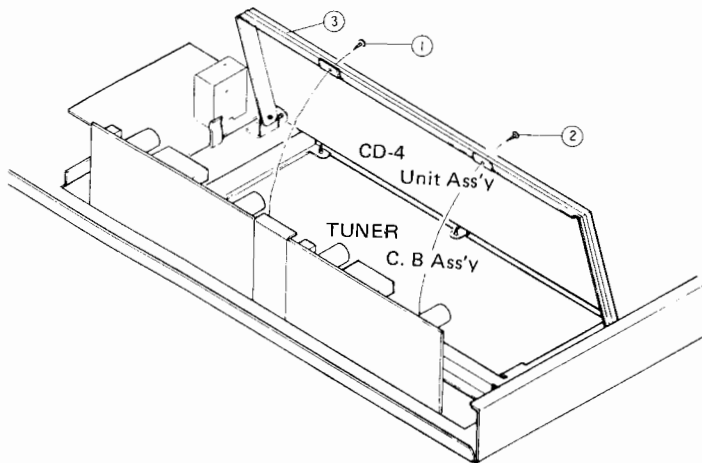
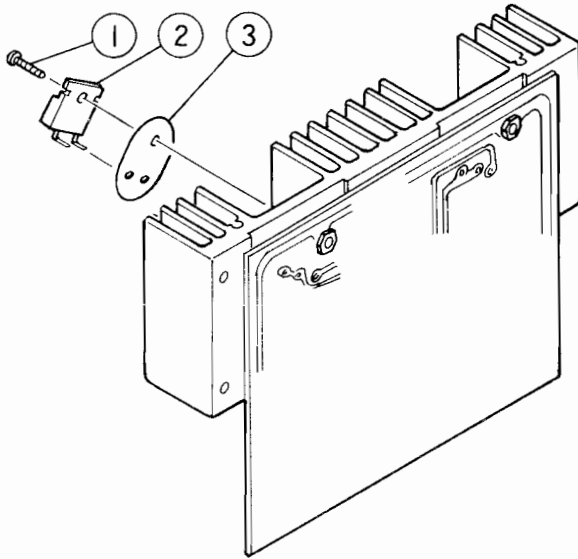

Fig. 7

①	Tapping Screw	SDSB3008N
②	"	SDSB3008N
③	CD-4 Unit Ass'y	CD4U-17
	{ CD-4 C. B Ass'y	TDM-22B
	{ C. B Bracket	E33449-001

# REPLACEMENT OF POWER TRANSISTOR



- ① LPSP3016NS Ass'y Screw
- ② Transistor (2SC789Y or 2SA489Y)
- ③ Mica Film

Fig. 8

# TRANSISTOR LEADS

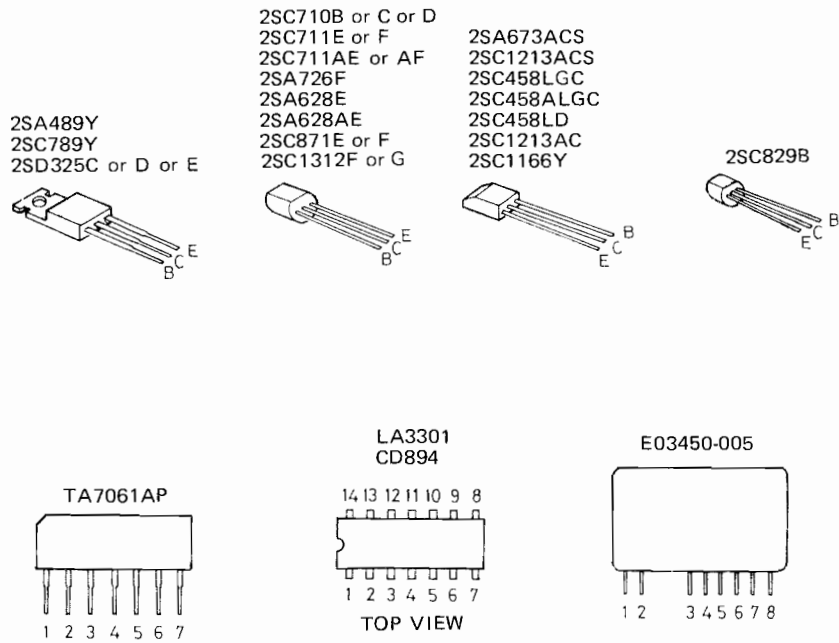

Fig. 9

## TUNER ALIGNMENT

TUNER C.B. ASS'Y IS DISTINGUISHED TWO TYPES AS FOLLOWS ;

FM DE-EMPHASIS	TUNER C.B. ASS'Y	DESCRIPTION
50 $\mu$ Sec	TFM-207GUA6	FOR EUROPE, AUSTRALIA
75 $\mu$ Sec	TFM-207GUA3	FOR AMERICA, CANADA, OTHERS

### BEFORE ALIGNMENT

1. Tuning dial is set to the proper point corresponding to no radio stations.
2. Connecting the RF generator to antenna terminal use the dummy antenna, refer to figure.
3. Use the insulated screw-driver adjusting the IFT.

#### STANDARD DUMMY ANTENNA

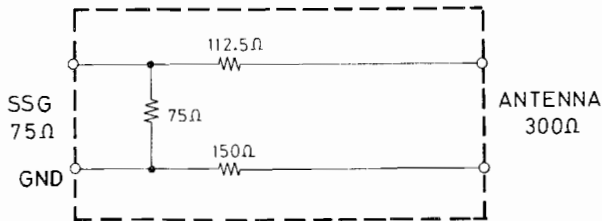

FM

Fig. 10

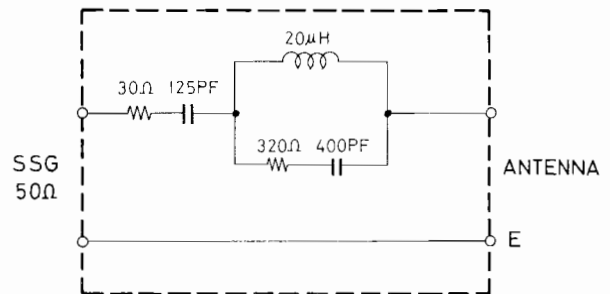

AM

Fig. 11

## AM ALIGNMENT

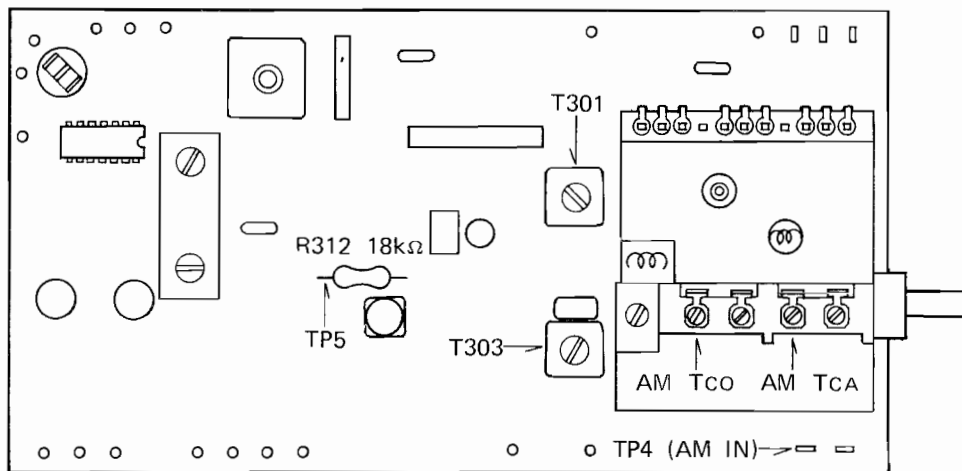

Fig. 12

### ADJUSTING IF STAGE

1. Connect the output of sweep generator set to 455kHz to the AM INPUT (TP4) of Tuner Circuit Board Ass'y (TFM-207).
2. Connect the input of sweep generator to the (TP5).
3. Adjust the core of I.F.T. T301 so that output is at max and symmetry as figure of right.

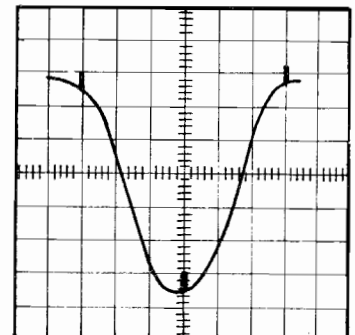

Fig. 13

## ADJUSTING TRACKING & SENSITIVITY

### LOW FREQUENCY

1. Connect the RF generator set to 600kHz modulation of 30% at 400Hz to the antenna terminal of the rear panel.
2. Connect VTVM to REC jack or speaker terminal.
3. Set dial pointer to 600kHz on the dial calibrations.
4. Adjust the OSC-trans T303 and ferrite bar antenna so that output is at max.

### HIGH FREQUENCY

1. Connect RF generator set to 1400kHz modulation of 30% at 400Hz to antenna terminal of the rear panel.
2. Connect VTVM to REC jack or speaker terminal.
3. Set dial pointer to 1400kHz on dial calibrations.
4. Adjust trimmer Tco AM and TCA AM of FRONT END so that output is at max.

## FM ALIGNMENT

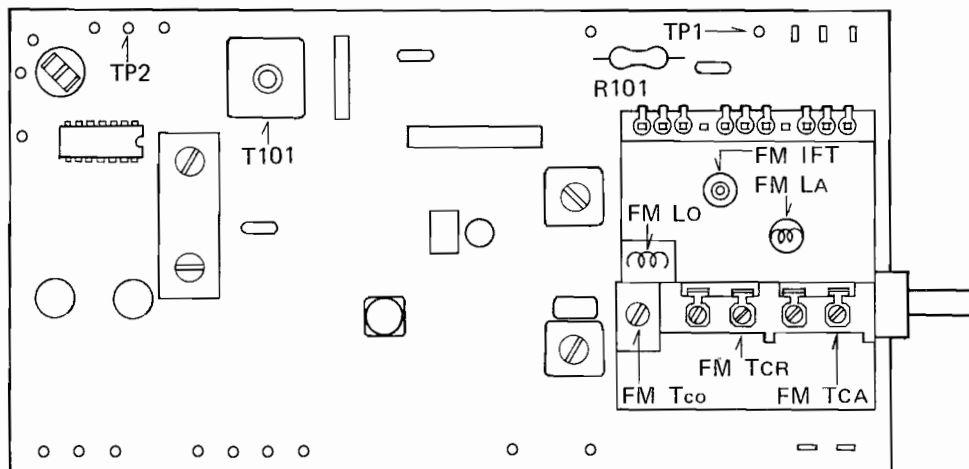

Fig. 14

## ADJUSTING DISCRIMINATOR

1. Connect sweep generator set to 10.7MHz to FM test point (TP1) through resistor 33k $\Omega$ .
2. Connect oscilloscope to the FM DET OUT (TP2).
3. Adjust the primary and the secondary of T101 so that wave form to be "S" curve as figure of right and to be maximum gain.

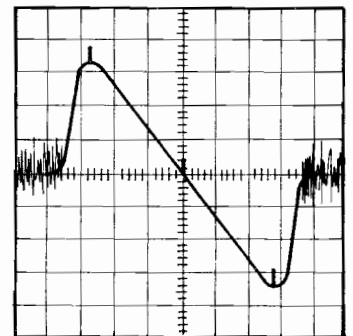

Fig. 15

## ADJUSTING CENTER METER & DISTORTION

1. Connect RF generator the modulation of 400Hz, the deviation of 75kHz to the antenna terminal of the rear panel through the dummy antenna.
2. Connect the oscilloscope and distortion meter to REC jack or speaker terminal.
3. Set the dial pointer to the proper position so as not to be tuned.
4. Adjust the secondary of T101 so that the center meter indicates just 0.
5. Set the generator to 98MHz and output 60dB.
6. Set the dial pointer 98MHz just tuned
7. Adjust the primary core of T101 so that distortion is at minimum, less than 0.5%.

Caution : T101 Primary Core is located at lower portion.  
Secondary Core is located at upper portion.



## ADJUST TRACKING AND SENSITIVITY

### LOW FREQUENCY

1. Connect RF generator to the antenna terminal of the rear panel through dummy antenna.
2. Set RF generator to 88MHz the modulation of 400Hz, the deviation of 75kHz and input  $10\mu V$ .
3. Connect VTVM and oscilloscope to REC jack or speaker terminal.
4. Set dial pointer to 88MHz on dial calibrations.
5. Adjust coil LO and LA of front-end so that output is at max.

### HIGH FREQUENCY

1. Set RF generator to 108MHz, the modulation of 400Hz, the deviation of 75kHz and the input of  $10\mu V$ .
2. Set dial pointer to 108MHz on dial calibrations.
3. Adjust trimmer FM TCO and TCA of Front-end so that output is at max.

## ADJUSTING MUTING LEVEL

1. Connect VTVM and oscilloscope to REC jack or speaker terminal.
2. Set RF generator to 98MHz modulation of 400Hz, deviation of 75kHz and input of 24~34dB.
3. Switch the source select to FM MUTING.
4. Cut out R101 when muting is operated under input level of 25dB.

## ADJUSTING OF MPX

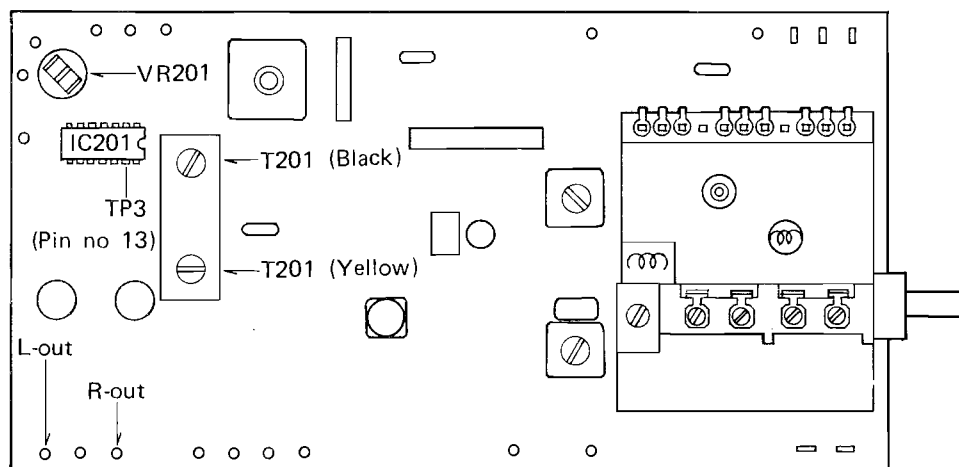

Fig. 16

1. Set stereo signal modulator to the following  
Modulation → 1000Hz  
Deviation Pilot only → 7.5kHz  
MAIN & SUB → 67.5kHz  
Output → EXT jack of RF signal generator
2. Connect RF generator to the antenna terminal of the rear panel through dummy antenna.
3. Connect VTVM, Oscilloscope and distortion meter to REC jack or speaker terminal.
4. Set RF generator to 98MHz, and the input 60dB (1mV).
5. Set dial pointer to 98MHz on dial calibrations.
6. Connect oscilloscope to TP3. (terminal of IC201 Pin No. 13)
7. Adjust T201 black core so that 19kHz level is at max.
8. Set stereo demodulator sub and pilot.
9. Adjust T201 yellow core so that L-channel or R-channel output is at maximum gain and at minimum distortion.

## ADJUSTING SEPARATION

10. Switch selector of stereo modulator to LEFT.
11. Adjust VR201 so that RIGHT channel output is at min.
12. Switch selector of stereo modulator to RIGHT.
13. Adjust VR201 so that LEFT channel output is at min.
14. In case of difference between right and left, set VR201 to average.

## AUDIO ALIGNMENT

### ADJUSTING IDLING CURRENT

#### ADJUSTING WITH AMMETER

1. Connect DC ammeter to collector of power transistor X713 and +B.
2. Adjust R745 semi fixed volume so that ammeter reading is 20mA.
3. Repeat same procedure as all the other channels.

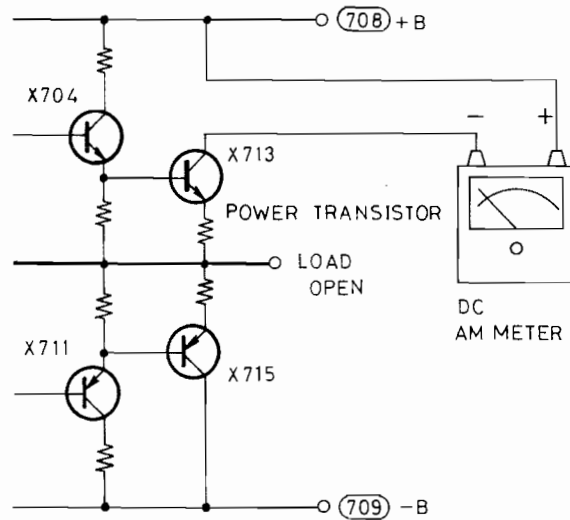

Fig. 17

#### ADJUSTING WITH MILIVOLT METER

1. Connect DC milivoltmeter to both end of emitter resistor R735, that is to connect milivoltmeter to the Test point of TAD-151 and speaker terminal corresponding to it.
2. Adjust R745 semi fixed volume so that milivoltmeter reading is 10mV.
3. Repeat same procedure as all the other channels.

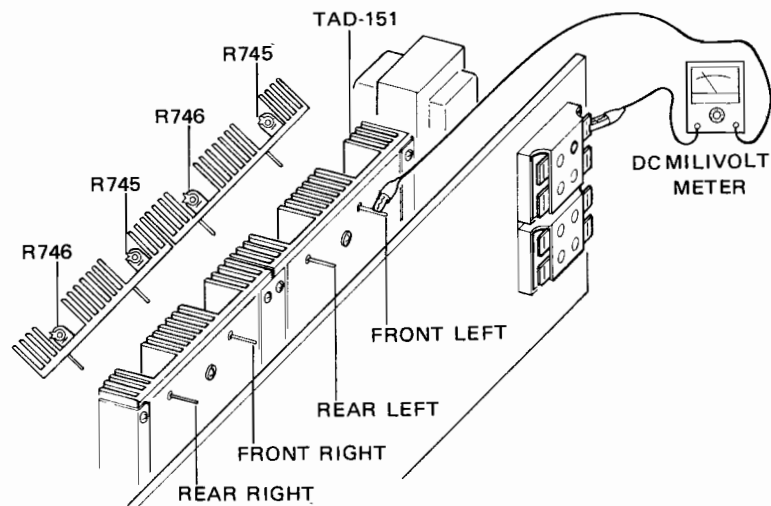
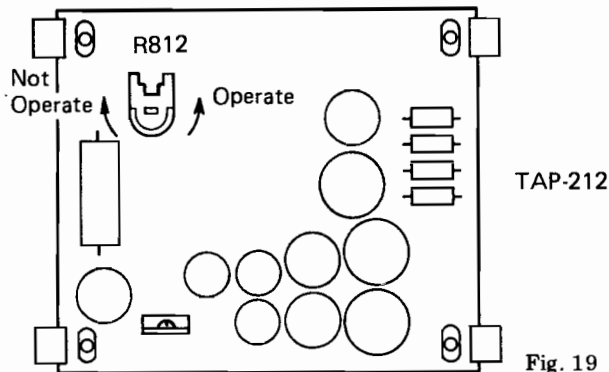

Fig. 18

Note : When you do it, set volume to minimum and take loads away from speaker terminal.

## ADJUSTING PROTECTION CIRCUIT

1. Connect audio oscillator set 1kHz to AUX input terminal.
2. Connect VTVM and oscilloscope to speaker terminal.
3. Set volume control so that speaker output is 1.5V.
4. Turn R812 semi-fixed volume of TAP-212 clockwise so that protector do not operate.
5. Shorting speaker terminal, turn R812 counter-clockwise slightly until protector begins to operate.
6. Take off short-circuit, please connect  $4\Omega$  loads to speaker terminal. Confirm that protector does not operate at full power.



## CD-4 ADJUSTMENT

CD-4 adjustment is to match cartridge and stylus with built-in demodulator. Once it has been done it need not be done again until cartridge or stylus is changed.

1. Set source select to CD-4/PHONO.
2. Set mode select to discrete 4CH.

### 30kHz LEVEL ADJUSTMENT

The 30kHz sub-channel carrier output differs between cartridges and this screw on the rear panel is to adjust the level.

1. Turn the 30kHz level screw clockwise until the stop position.
2. On the inside band of CD-4 Adjustment Record there is a 400Hz sub channel signal (4kHz deviation). If the signal is distorted play BAND 4 on adjustment record and turn the screw counter-clockwise until a position is reached where distorted sound is not heard.

Although distorted sound may still be heard, it might be acceptable in sound quality when playing CD-4 music records with setting remaining in the start position.

If the sound is still unsatisfactory with CD-4 music record, the cartridge is then considered inadequate for CD-4 record reproduction.

### SEPARATION ADJUSTMENT

1. Lower the volume of front speakers so that sound is only heard from the rear speakers.
2. Left Channel (CH-1, CH-2) Adjust : Turn the left control of Separation Adjust so that the volume of rear left (CH-2) is as low as possible while playing BAND 1 on the outside band of CD-4 demodulator adjustment record (4DE-205).
3. Right Channel (CH-3, CH-4) Adjust : Turn the right channel, in the same way, by turning Right Control to minimize the volume of rear right while playing BAND 2.
4. When operation have been completed, the adjustment is over and the volume of the front speakers should be turned up.



Fig. 20

**THE LIST OF FRONT PANEL PARTS FOR REPLACEMENT**

Dwg. No.	Parts No.	Parts Name	Description
1	E1750-003	Front Panel Ass'y	
2a	E45979-013	Spacer	
2b	E45979-012	Spacer	For Power Switch
3	E33541-001	Balance Remote Cap Ass'y	
4	E48753-001	Select Knob	For Speaker, Source, Mode
5	E48600-001	Tuning Knob	
6a	E48602-001	Double Knob	inside For Volume Balance
6b	E48603-001	Double Knob	outside For Volume Balance
7	E48601-001	Volume Knob	Tone
8	E48864-001	SEA Knob	
9	E1752-001	Front Bracket Ass'y	
10	E48584-001	Roller Bracket Ass'y	
11	E48582-001	Roller Bracket Ass'y	
12	E48720-002	Roller Bracket Ass'y	
13	E48585-001	Reflector	CD-4 Rader
14	E48587-003	Mini Screen	Orange
16	E48586-001	Reflector	STEREO Radar
17	E48587-002	Mini Screen	Red
19	E48586-002	Reflector	Mode
22	E03176-011B	Tuning Indicator	
23	E03176-010	Center Meter	
24	E48861-001	Meter Holder Ass'y	
25	E33509-001	Lamp House	
26	E21353-002	Reflector	
27	TAC-306C	Lamp Circuit Board Ass'y	
28	QLP4101-001	Fuse Lamp	12.6V 300mA
29	E33510-001	Tuning Shaft Ass'y	
30	E48583-001	Roller Bracket Ass'y	
32	E48594-002	Balance Remote Holder	
33	QMC0889-002	8 Pin Socket	
34	E48923-001	Spacer	
35	E03468-002	Headphone Jack Ass'y	
36	QSR3183-202	Rotary Switch	
37	TAC-305B	Select Switch C.B. Ass'y	
38	TAC-360	Tone Control C.B. Ass'y	
39	TAC303A	SEA Coil C.B. Ass'y	
40	E33445-001	Dial Scale	
41	E33511-003	Color Screen	
42	E33476-001	Scale Holder	
43	E33502-001	Needle Ass'y	

DWG. NO. 31 POWER SWITCH IS DISTINGUISHED THREE TYPES AS FOLLOWS ;

Parts No.	Parts Name	Description
QSU1221-001	Power Switch	FOR AMERICA, CANADA
QSY2220-004	"	FOR EUROPE (SEMKO, SEV AREA AND ENGLAND), AUSTRALIA
QSL1135-007	"	OTHER AREA

EXPLODED VIEW OF FRONT PANEL PARTS

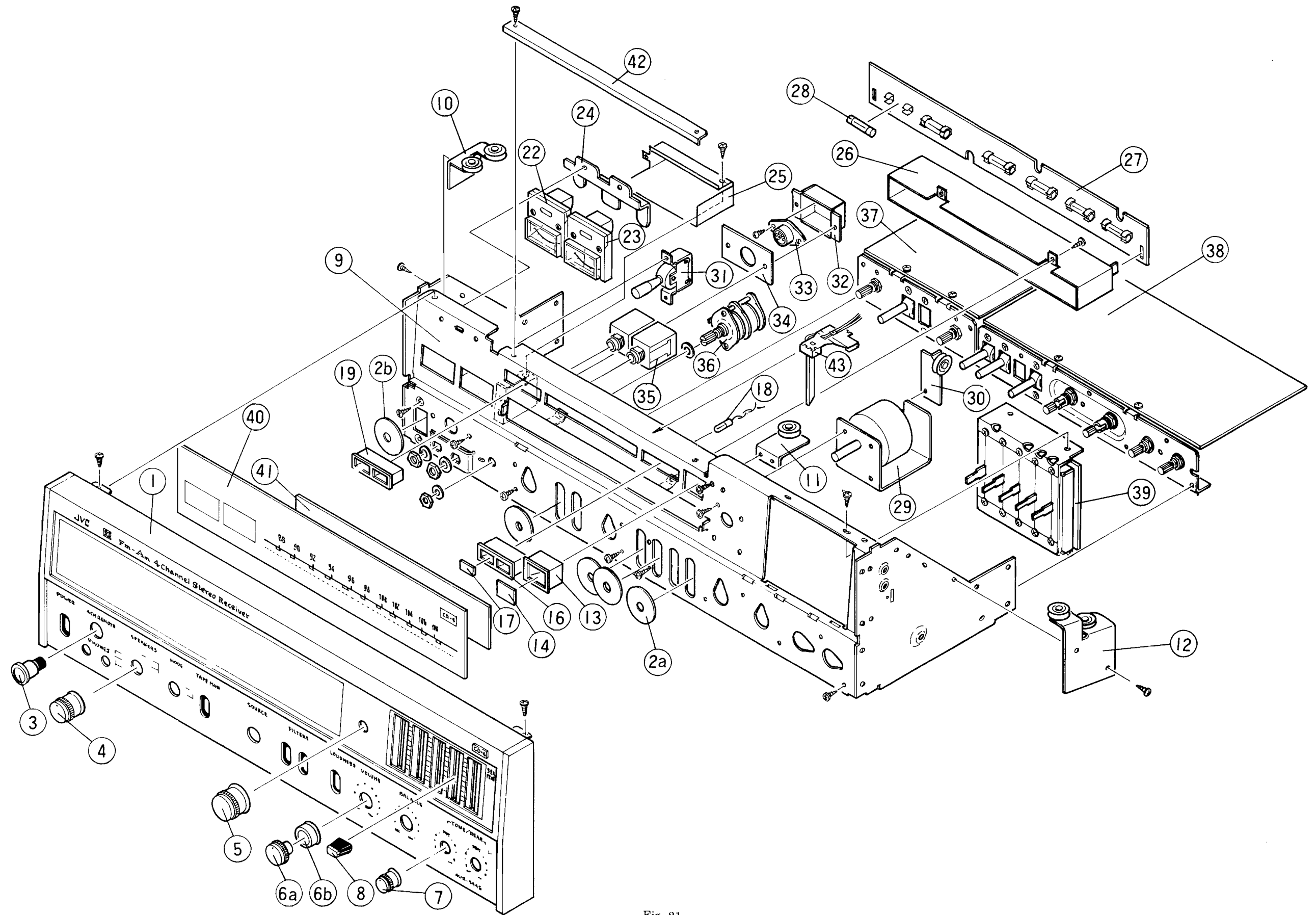

Fig. 21

EXPLODED VIEW OF REAR PANEL PARTS

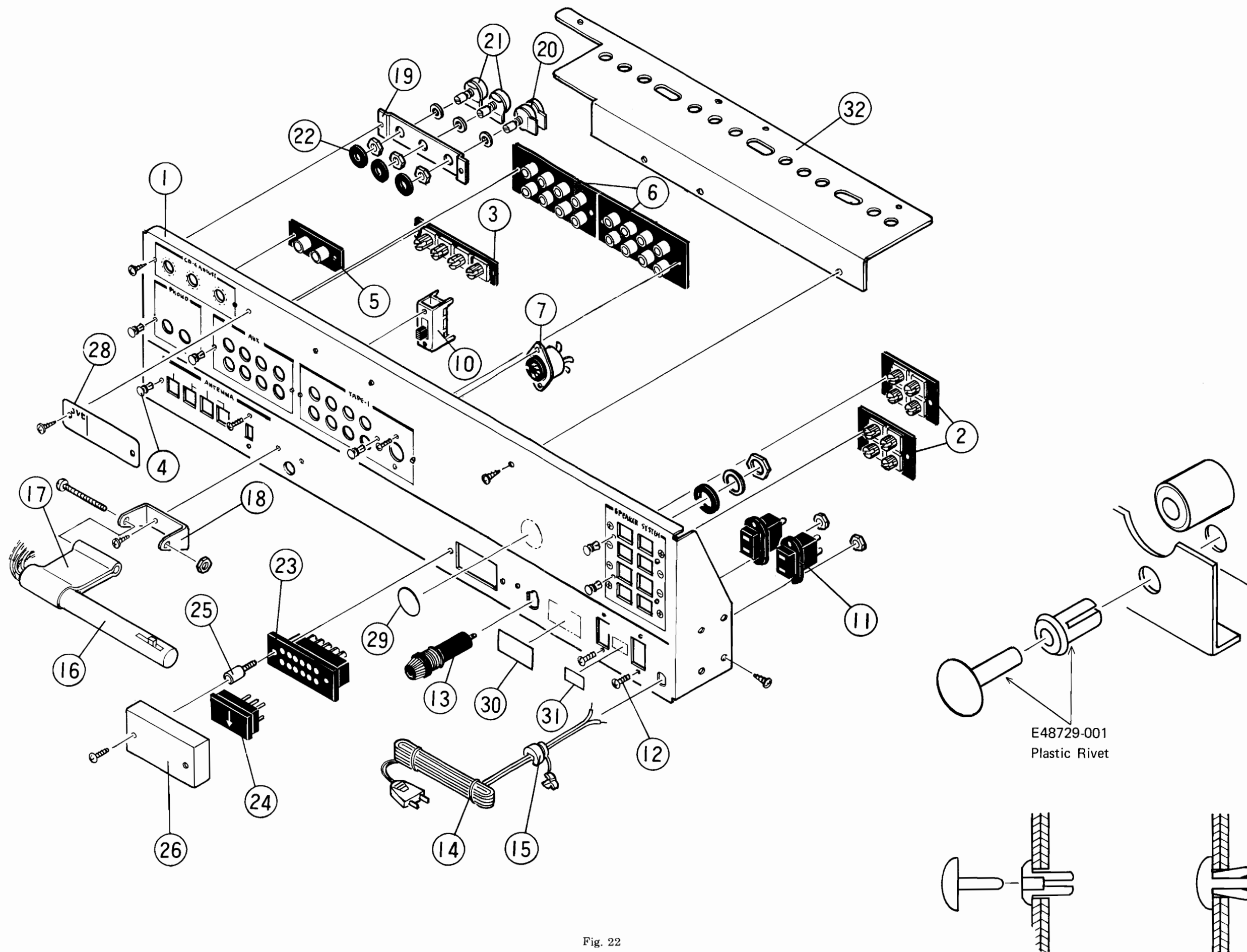

Fig. 22

**THE LIST OF REAR PANEL PARTS FOR REPLACEMENT**

Dwg. No	Parts No.	Parts Name	Description
1	E1755-009	Rear Panel	Speaker  For ANTENNA, PHONO, AUX, TAPE PHONO AUX, TAPE  FM DET OUT   50K(B) FOR 30KHz LEVEL ADJUST 10K(B) FOR SEPARATION ADJUST
2	E03572-001	Terminal Ass'y	
3	E03572-002	Terminal Ass'y	
4	E48729-001	Plastic Rivet	
5	E03043-20	Pin Jack Ass'y	
6	E03043-80B	Pin Jack Ass'y	
7	E03571-001	DIN Socket Ass'y	
8	E03043-10	Pin Jack Ass'y	
10	QSS4224-002	Slide Switch	
16	E03037-25	Bar Antenna Coil	
17	E41021	Bar Antenna Holder	
18	E50634-002	Bar Antenna Bracket	
19	E48598-001	Volume Bracket	
20	E03504-004	Variable Resistor	
21	E03415-003	Variable Resistor	
22	E42000-014	Spacer	
32	E33513-001	Sub Heat Sink	

DWG. NO.	AREA PARTS NAME	AMERICA	CANADA	EUROPE				AUSTRALIA	PACEX	OTHER AREA
				SEMKO AREA	SEV AREA	ENGLAND	OTHER AREA			
11	CONNECTOR	QMC0234-001		OMITTED (E48782-002 PLATE)			QMC0234-001	OMITTED (E48782-002 PLATE)	QMC0234-001	
12	SCREW	SPKP3010S	SDSP3010MS	OMITTED			SPKP3010S	OMITTED	SPKP3010S	
13	FUSE HOLDER	QMG0201-001	QMG0102-001	QMG0301-002	QMG0102-001	QMG0201-001	QMG0102-001	QMG0201-001		
14	POWER CORD WITH PLUG	QMP1200-224		E03544-001	QMP3800-240	E03551-002	QMP1200-224	E03551-002	QMP1200-224	
15	POWER CORD STOPPER	E31704-003			E31704-002	E31704-003	E31704-002	E31704-003		
23	VOLTAGE SELECT SOCKET	OMITTED (E47977-003 PLATE)				QMC9004-001	OMITTED (E47977-003 PLATE)	QMC9004-001		
24	VOLTAGE SELECT PLUG	OMITTED				QMC9005-001	OMITTED	QMC9005-001		
25	STUD	OMITTED				E44182-008S	OMITTED	E44182-008S		
26	COVER	OMITTED				E46603-001	OMITTED	E46603-001		
28	RATING PLATE	E48761-026	E48761-027	E48761-030	E48761-031	E48761-028	E48761-031	E48761-029   E48761-028		
30	CAUTION LABEL	E44777-009	E48201-003	E46264-006	E43716-005	E45314-015	E43716-005	E43716-015		
31	RATING LABEL	E45861-001			OMITTED					

CIRCUIT BOARD ASS'Y

TAP-212 (POWER SUPPLY C.B. ASS'Y)

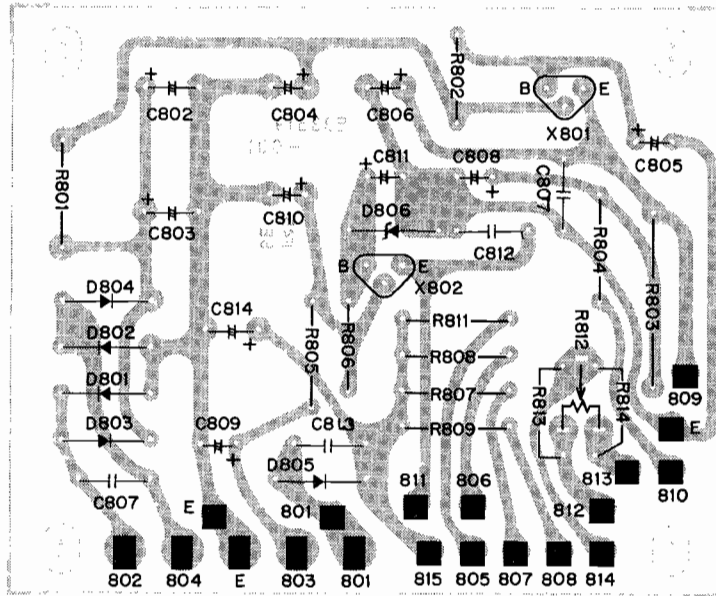

Fig. 23

TAP-212 (POWER SUPPLY C.B. ASS'Y) PARTS LIST

Ref No.	Parts No.	Description
• TRANSISTORS		
X801	2SC789Y	Silicon Transistor (TOSHIBA)
X802	2SD325D or E	" (SANYO)
• DIODES		
D801~805	FR2-02	Silicon Diode (FUJI)
D806	E0771-12	Silicon Zener Diode (WZ-130) (JRC)
• RESISTORS		
R801	E03347-1-330	Metal Film 33Ω ±10% 1W
R802	QRD141J-103	Carbon 10kΩ ±5% ¼W
R803	QRF031K-101	Unflame 100Ω ±10% 3W
R804	E03347-1-330	Metal Film 33Ω ±10% 1W
R805	E03347-1-470	Metal Film 47Ω ±10% 1W
R806	QRD141J-332	Carbon 3.3kΩ ±5% ¼W
R808	QRG011K-221	Oxide Metal 220Ω ±10% 1W
R809	E03347-1-470	Metal Film 47Ω ±10% 1W
R810		
R811	E03347-1-470	Metal Film 47Ω ±10% 1W
R812	QVP8A0B-014	Mini Variable 10kΩ(B)
• CAPACITORS		
C801	QCF12HP-103	Ceramic 0.01μF +100% -0% 500V
C802,803	QEW41JA-227	Electrolytic 220μF +100% -0% 63V
C804,805	QEW41HA-107	" 100μF +100% -0% 50V
C806	QEW41HA-476	" 47μF +100% -0% 50V
C807	QCF11HP-103	Ceramic 0.01μF +100% -0% 50V
C808	QEW41VA-107	Electrolytic 100μF +100% -0% 35V
C809	QEW41VA-227	" 220μF +100% -0% 35V
C810	QEW41EA-227	" 220μF +100% -0% 25V
C811	QEW41CA-107	" 100μF +100% -0% 16V
C812,813	QCF11HP-103	Ceramic 0.01μF +100% -0% 50V
C814	QEW41EA-108	Electrolytic 1000μF +100% -0% 25V



TAP-238 (PROTECTOR C.B. ASS'Y)

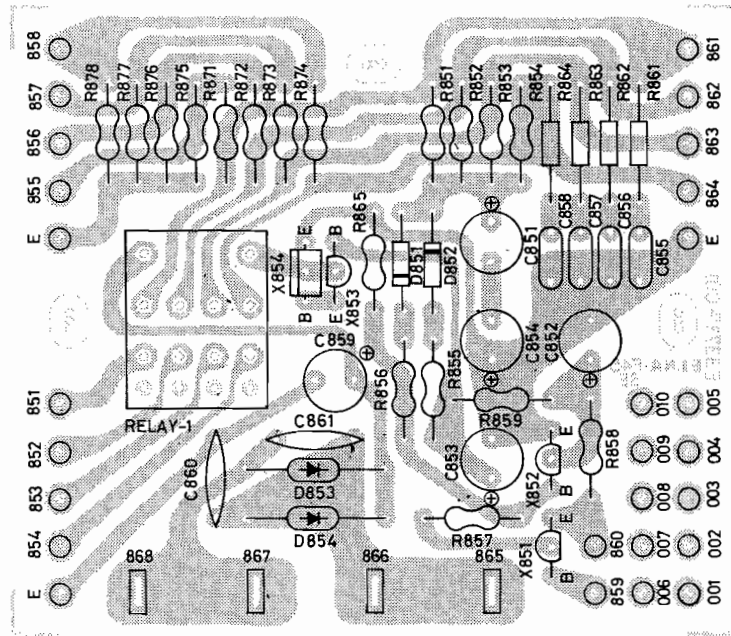

Fig. 24

TAP-238 (PROTECTOR C.B. ASS'Y) PARTS LIST

Ref. No.	Parts No.	Description			
• TRANSISTORS					
X851	2SA628AE	Silicon (MITSUBISHI)			
X852,853	2SC711AE	" ( " )			
X854	2SC1213AC	" ( " )			
• DIODES					
D851,852	1S426GFM	Ge (SANYO)			
D853,854	FR2-02	Silicon (FUJI)			
• RESISTORS					
R851~854	QRD141J-223	Carbon	22kΩ	±5%	¼W
R855	QRD141J-103	"	10kΩ	±5%	¼W
R856	QRD141J-563	"	56kΩ	±5%	¼W
R857	QRD141J-273	"	27kΩ	±5%	¼W
R858	QRD141J-184	"	180kΩ	±5%	¼W
R859	QRD141J-562	"	5.6kΩ	±5%	¼W
R861~864	QRC121K-100	Composition	10Ω	±10%	½W
R865	QRD141J-822	Carbon	8.2kΩ	±5%	¼W
• CAPACITORS					
C851	QEW41CA-107	Electrolytic	100μF	+100% -0%	16V
C852	QEW41HA-476	"	47μF	+100% -0%	50V
C853	QEW41AA-107	"	100μF	+100% -0%	10V
C854	QEW41CA-107	"	100μF	+100% -0%	16V
C855~858	QFM41HK-473	Mylar	0.047μF	±10%	
C859	QEW41VA-226	Electrolytic	22μF	+100% -0%	35V
C860	QCF12HP-103	Ceramic	0.01μF	+100% -0%	500V
C861	QCF12HP-103	"	0.01μF	+100% -0%	500V
• OTHERS					
	SD403P-24B or MY4-0	(FUJISOKU) Relay 24V 40mA (OMRON)			

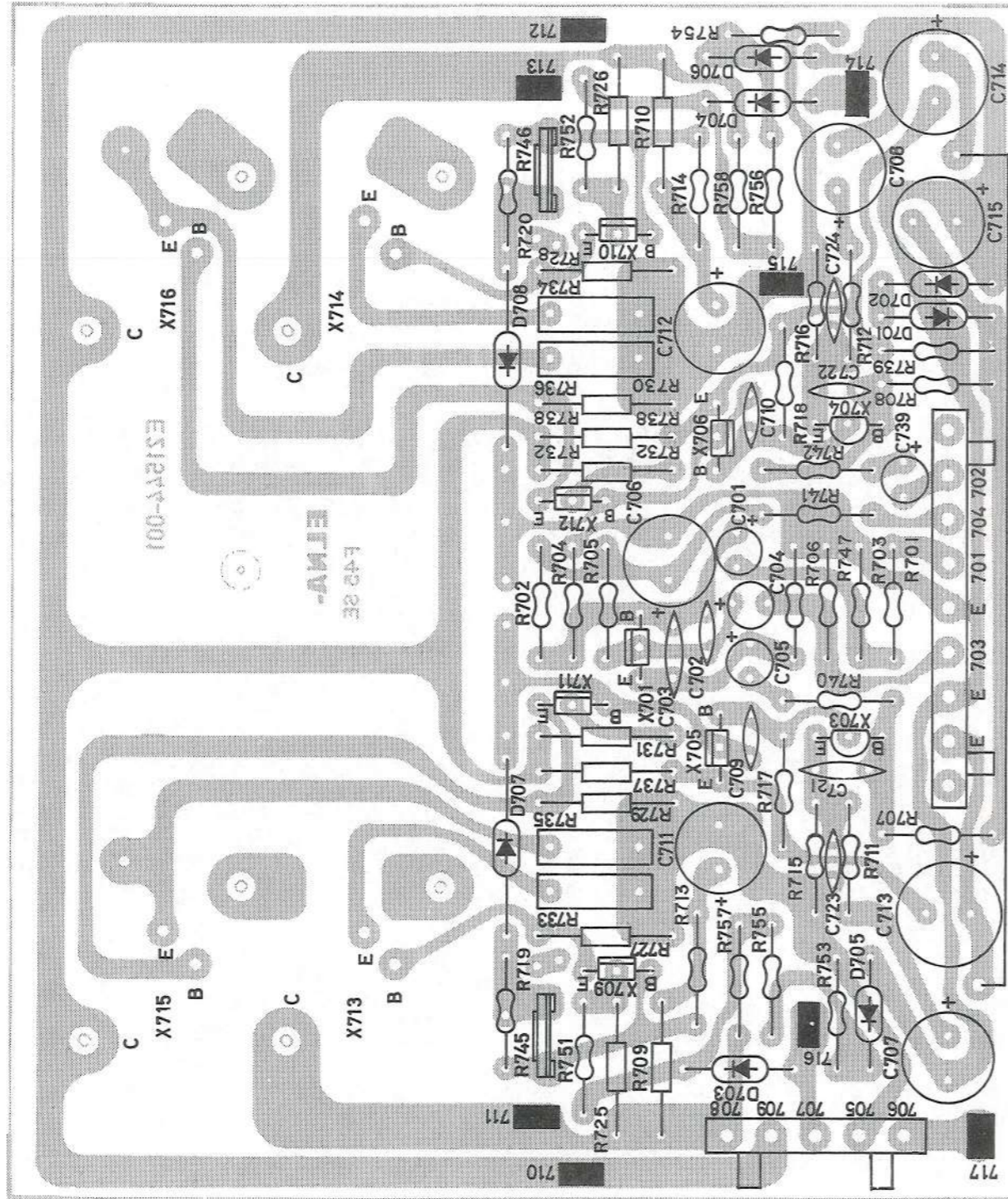

Fig. 26

Ref. No.	Parts No.	Description			
• TRANSISTORS					
X701	2SC458LGC	Silicon Transistor (HITACHI)			
X703,704	2SA726F	" (MITSUBISHI)			
X705,706	2SC1213ACS	" (HITACHI)			
X709,710	2SC1213ACS	" ( " )			
X711,712	2SA673ACS	" ( " )			
X713,714	2SC789Y	" (TOSHIBA)			
X715,716	2SA489Y	" ( " )			
• DIODES					
D701,702	1S990	Silicon Diode (JRC)			
D703~706	1S2473	" (TOYO DENGU)			
D707,708	SV03	Silicon Varistor (SANKEN)			
• RESISTORS					
R701	QRD141J-222	Carbon	2.2k $\Omega$	$\pm 5\%$	1/4W
R702	QRD141J-334	"	330k $\Omega$	"	"
R703	QRD141J-474	"	470k $\Omega$	"	"
R704	QRD141J-124	"	120k $\Omega$	"	"
R705,706	QRD141J-562	"	5.6k $\Omega$	"	"
R707,708	QRD141J-563	"	56k $\Omega$	"	"
R709,710	QRC121K-222	Composition	2.2k $\Omega$	$\pm 10\%$	1/4W
R711,712	QRD141J-470	Carbon	47 $\Omega$	$\pm 5\%$	1/4W
R713,714	QRD141J-392	"	3.9k $\Omega$	"	"
R715~718	QRD141J-562	"	5.6k $\Omega$	"	"
R719,720	QRD141J-221	"	220 $\Omega$	"	"
R725,726	QRC121K-330	Composition	33 $\Omega$	$\pm 10\%$	1/4W
R727~730	QRC121K-271	"	270 $\Omega$	"	"
R731,732	QRC121K-330	"	33 $\Omega$	"	"
R733~736	QRM035K-R47	Metal Plate	0.47 $\Omega$	$\pm 10\%$	3W
R737,738	QRC121K-221	Composition	220 $\Omega$	$\pm 10\%$	1/4W
R739	QRD141J-563	Carbon	56k $\Omega$	$\pm 5\%$	1/4W
R740	QRD141J-222	"	2.2k $\Omega$	"	"
R741	QRD141J-472	"	4.7k $\Omega$	"	"
R742	QRD141J-472	"	4.7k $\Omega$	"	"
R745,746	QVP1A0B-052	Mini Variable	500 $\Omega$ (B)	"	"
R747	QRD141J-473	Carbon	47k $\Omega$	$\pm 5\%$	1/4W
R751,752	QRD141J-103	"	10k $\Omega$	"	"
R753,754	QRD141J-472	"	4.7k $\Omega$	"	"
R755,756	QRD141J-473	"	47k $\Omega$	"	"
R757,758	QRD141J-122	"	1.2k $\Omega$	"	"
• CAPACITORS					
C701	QEW41HA-105E	Electrolytic	1 $\mu$ F	+100% -0%	50V
C702	QCS11HJ-560	Ceramic	56pF	$\pm 5\%$	50V
C703	QCS11HJ-471	"	470pF	"	"
C704,705	QEW41HA-105E	Electrolytic	1 $\mu$ F	+100% -0%	50V
C706	QEW41EA-476	"	47 $\mu$ F	+100% -0%	25V
C707,708	QEW40JA-477	"	470 $\mu$ F	+100% -0%	6.3V
C709,710	QCS11HJ-120	Ceramic	12pF	$\pm 5\%$	50V
C711,712	QEW41HA-476	Electrolytic	47 $\mu$ F	+100% -0%	50V
C713,714	QEW41VA-227	"	220 $\mu$ F	+100% -0%	35V
C715	QEW40JA-227	"	220 $\mu$ F	+100% -0%	6.3V
C721,722	QCS11HJ-471	Ceramic	470pF	$\pm 5\%$	50V
C723,724	QCS11HJ-271	"	270pF	"	"
C739	QEW41HA-105E	Electrolytic	1 $\mu$ F	+100% -0%	50V
• OTHER					
	E33515-001	Heat Sink			

TAC-305B (SELECT SWITCH C.B. ASS'Y)

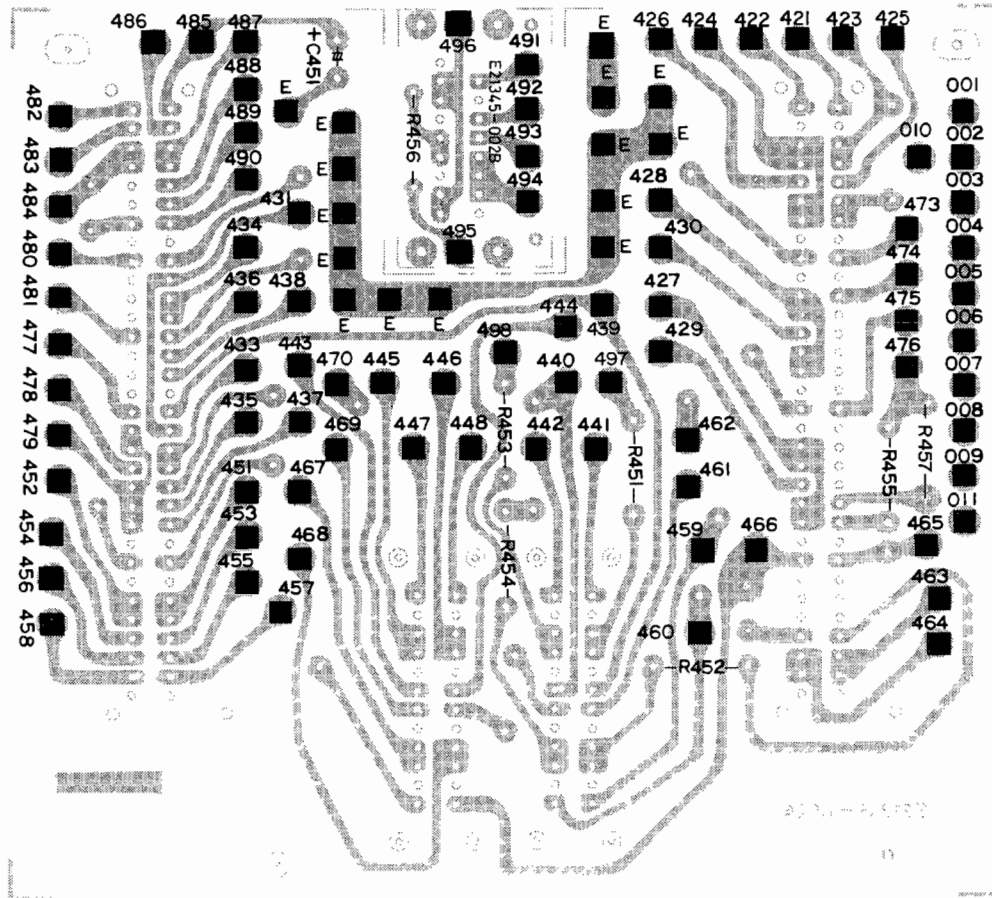

Fig. 25

TAC-305B (SELECT SWITCH C.B. ASS'Y) PARTS LIST

Ref. No.	Parts No.	Description
• RESISTORS		
R451~454	QRD141J-472	Carbon 4.7k $\Omega$ $\pm$ 5% 1/4W
R456	QRD141J-102	" 1k $\Omega$ $\pm$ 5% 1/4W
R457	QRD141J-274	" 270k $\Omega$ $\pm$ 5% 1/4W
R455	QRD141J-333	" 33k $\Omega$ $\pm$ 5% 1/4W
• SWITCHES		
S451	QSR0058-001	Slide Rotary 8C-6P Source
S452	QSR0056-001	Slide Rotary 10C-5P Mode
S453	QSL0001-002	Lever 4C-2P TAPE

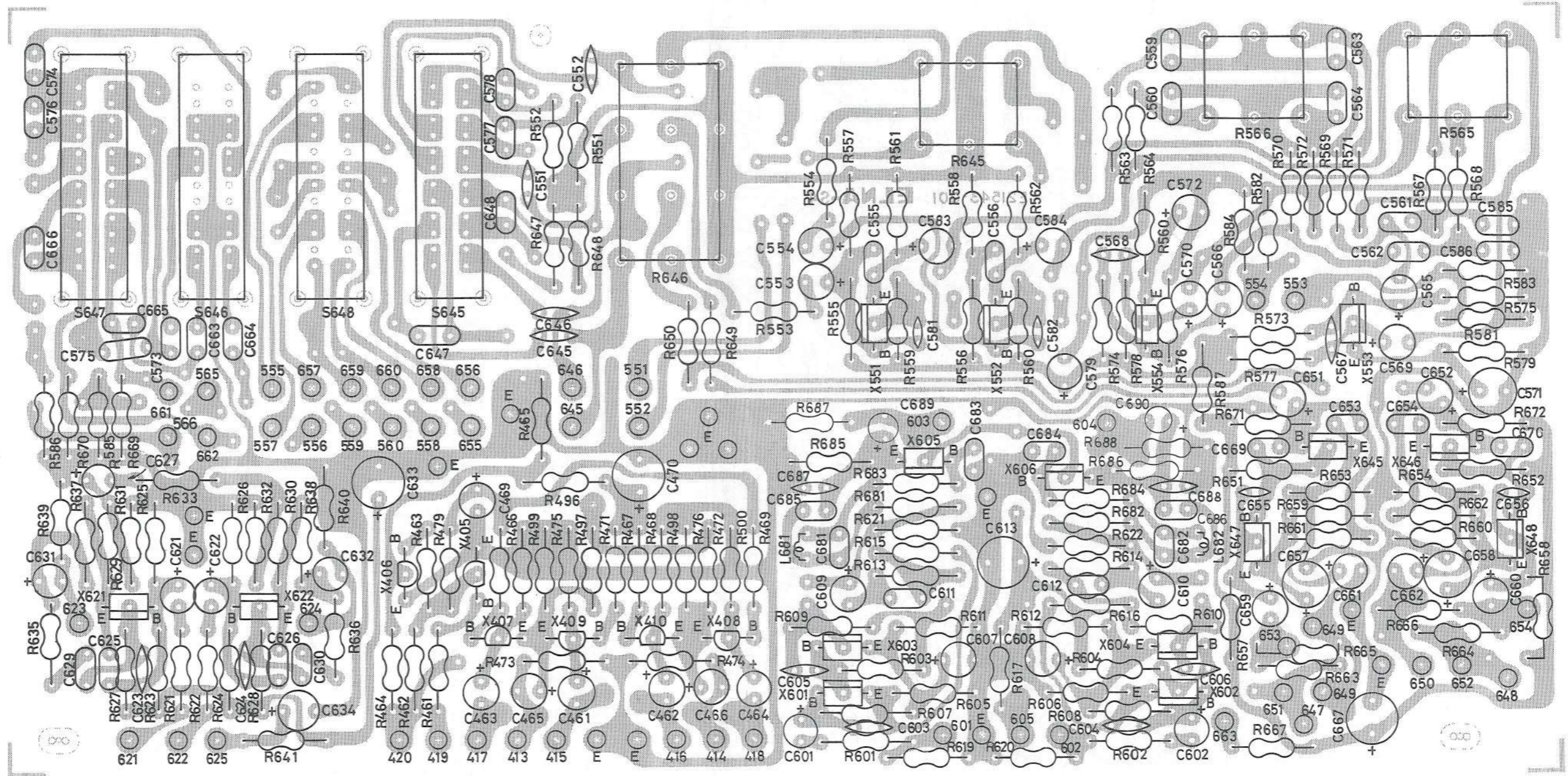

Fig. 27

TAC-360 (TONE CONTROL C.B. ASS'Y) PARTS LIST

Ref. No.	Parts No.	Description			
• TRANSISTORS					
X551,552	2SC458LGC	Silicon Transistor (HITACHI)			
X601~604	2SC458ALGC	"	( " )		
X605,606	2SC458ALGC	"	( " )		
X621,622	2SC458LGC	"	( " )		
X645,646	2SC458LGC	"	( " )		
• RESISTORS					
R551,552	QRD141J-223	Carbon	22k $\Omega$	$\pm 5\%$	1/4W
R553,554	QRD141J-471	"	470 $\Omega$	"	"
R555~558	QRD141J-394	"	390k $\Omega$	"	"
R559~562	QRD141J-223	"	22k $\Omega$	"	"
R563,564	QRD141J-332	"	3.3k $\Omega$	"	"
R565,566	QVZ1209-006	Volume	50k $\Omega$ x 2(W)		
R567,568	QRD141J-561	Carbon	560 $\Omega$	$\pm 5\%$	1/4W
R571,572	QRD141J-332	"	3.3k $\Omega$	"	"
R581,582	QRD141J-562	"	5.6k $\Omega$	"	"
R587	QRD141J-331	"	330 $\Omega$	"	"
R601,602	QRD141J-222	"	2.2k $\Omega$	"	"
R603,604	QRD141J-104	"	100k $\Omega$	"	"
R605,606	QRD141J-272	"	2.7k $\Omega$	"	"
R607,608	QRD141J-334	"	330k $\Omega$	"	"
R609,610	QRD141J-472	"	4.7k $\Omega$	"	"
R611,612	QRD141J-681	"	680 $\Omega$	"	"
R613,614	QRD141J-393	"	39k $\Omega$	"	"
R615,616	QRD141J-182	"	1.8k $\Omega$	"	"
R617	QRD146J-101	Unflame	100 $\Omega$	"	"
R621,622	QRD141J-222	Carbon	2.2k $\Omega$	"	"
R623,624	QRD141J-684	"	680k $\Omega$	"	"
R625,626	QRD141J-474	"	470k $\Omega$	"	"
R627,628	QRD141J-472	"	4.7k $\Omega$	"	"
R629,630	QRD141J-821	"	820 $\Omega$	"	"
R631,632	QRD141J-392	"	3.9k $\Omega$	"	"
R633	QRD141J-472	"	4.7k $\Omega$	"	"
R635,636	QRD141J-222	"	2.2k $\Omega$	"	"
R637,638	QRD141J-153	"	15k $\Omega$	"	"
R639,640	QRD141J-683	"	68k $\Omega$	"	"
R641	QRD141J-152	"	1.5k $\Omega$	"	"
R645	QVE4A3W-6F5	Volume	250K x 2(W) (Balance)		
R646	QVZ1401-003	"	250K x 4(B) (Master Volume)		
R647,648	QRD141J-223	Carbon	22k $\Omega$	$\pm 5\%$	1/4W
R649,650	QRD141J-471	"	470 $\Omega$	"	"
R651,652	QRD141J-332	"	3.3k $\Omega$	"	"
R653,654	QRD141J-222	"	2.2k $\Omega$	"	"
R659,660	QRD141J-0R0	Jumping Resistor		0 $\Omega$	
R661,662	QRD141J-124	Carbon	120k $\Omega$	$\pm 5\%$	1/4W
R663,664	QRD141J-562	"	5.6k $\Omega$	"	"
R667	QRD141J-102	"	1k $\Omega$	"	"
R671,672	QRD141J-224	"	220k $\Omega$	"	"
OTHERS	QRD141J-0R0	Jumping Resistor		0 $\Omega$ (QTY 8)	
• CAPACITORS					
C525,526	QEW41HA-475	Electrolytic	4.7 $\mu$ F	+100% -0%	50V
C551,552	QCS11HJ-331	Ceramic	330pF	$\pm 5\%$	50V
C553,554	QEB41EM-105	Electrolytic	1 $\mu$ F	$\pm 20\%$	25V(LLC)

Ref. No.	Parts No.	Description			
C555,556	QFM41HK-102	Mylar	0.001 $\mu$ F	$\pm 10\%$	50V
C559,560	QFM41HK-823	"	0.082 $\mu$ F	"	"
C563,564	QFM41HK-823	"	0.082 $\mu$ F	"	"
C573,574	QFM41HK-682	"	0.0068 $\mu$ F	"	"
C575,576	QFM41HK-223	"	0.022 $\mu$ F	"	"
C577,578	QFM41HK-103	"	0.01 $\mu$ F	"	"
C579	QEW41EA-476	Electrolytic	47 $\mu$ F	+100% -0%	25V
C581,582	QCS11HJ-560	Ceramic	56pF	$\pm 5\%$	50V
C583,584	QEW41HA-475	Electrolytic	4.7 $\mu$ F	+100% -0%	50V
C585,586	QFM41HK-153	Mylar	0.015 $\mu$ F	$\pm 10\%$	50V
C601,602	QEB41EM-224	Electrolytic	0.22 $\mu$ F	$\pm 20\%$	25V(LLC)
C603,604	QCS11HJ-331	Ceramic	330pF	$\pm 5\%$	50V
C605,606	QCS11HJ-560	"	56pF	"	"
C607,608	QEW41AA-336	Electrolytic	33 $\mu$ F	+100% -0%	10V
C609,610	QEW41HA-475	"	4.7 $\mu$ F	" "	50V
C611,612	QEM41HJ-182	Mylar	0.0018 $\mu$ F	$\pm 5\%$	50V
C613	QEW41HA-476	Electrolytic	47 $\mu$ F	+100% -0%	50V
C621,622	QEB41EM-105	"	1 $\mu$ F	$\pm 20\%$	25V(LLC)
C623,624	QCS11HJ-101	Ceramic	100pF	$\pm 5\%$	50V
C625,626	QFM41HK-102	Mylar	0.001 $\mu$ F	$\pm 10\%$	50V
C627	QEW41HA-105	Electrolytic	1 $\mu$ F	+100% -0%	50V
C629	QFM41HK-683	Mylar	0.068 $\mu$ F	$\pm 10\%$	50V
C630	QFM41HK-103	"	0.01 $\mu$ F	"	"
C631,632	QEW41HA-105	Electrolytic	1 $\mu$ F	+100% -0%	50V
C633	QEW41EA-107	"	100 $\mu$ F	" "	25V
C634	QEW41HA-475	"	4.7 $\mu$ F	" "	50V
C645,646	QCS11HJ-331	Ceramic	330pF	$\pm 5\%$	50V
C647,648	QFM41HK-103	Mylar	0.01 $\mu$ F	$\pm 10\%$	50V
C651,652	QEB41EM-105	Electrolytic	1 $\mu$ F	$\pm 20\%$	25V(LLC)
C653,654	QFM41HK-102	Mylar	0.001 $\mu$ F	$\pm 10\%$	50V
C659,660	QEW41EA-336	Electrolytic	33 $\mu$ F	+100% -0%	25V
C661,662	QEW41CA-336	"	33 $\mu$ F	" "	16V
C663,664	QFM41HK-103	Mylar	0.01 $\mu$ F	$\pm 10\%$	50V
C665,666	QFM41HK-473	"	0.047 $\mu$ F	"	"
C667	QEW41EA-107	Electrolytic	100 $\mu$ F	+100% -0%	25V
C669,670	QCS11HJ-560	Ceramic	56pF	$\pm 5\%$	50V
C681~684	QFM41HJ-272	Mylar	0.0027 $\mu$ F	$\pm 5\%$	50V
C685,686	QFM41HJ-472	"	0.0047 $\mu$ F	$\pm 5\%$	"
C687,688	QCS11HJ-151	Ceramic	150pF	$\pm 5\%$	50V
C689,690	QEW41HA-475	Electrolytic	4.7 $\mu$ F	+100% -0%	50V
• INDUCTORS					
L681,682	E03566-103	Ferri Inductor	10mH		
• OTHERS					
S645~647	QSL0001-002	Lever Switch	4C-2P		

TAC-303 (SEA CONTROL C.B. ASS'Y)

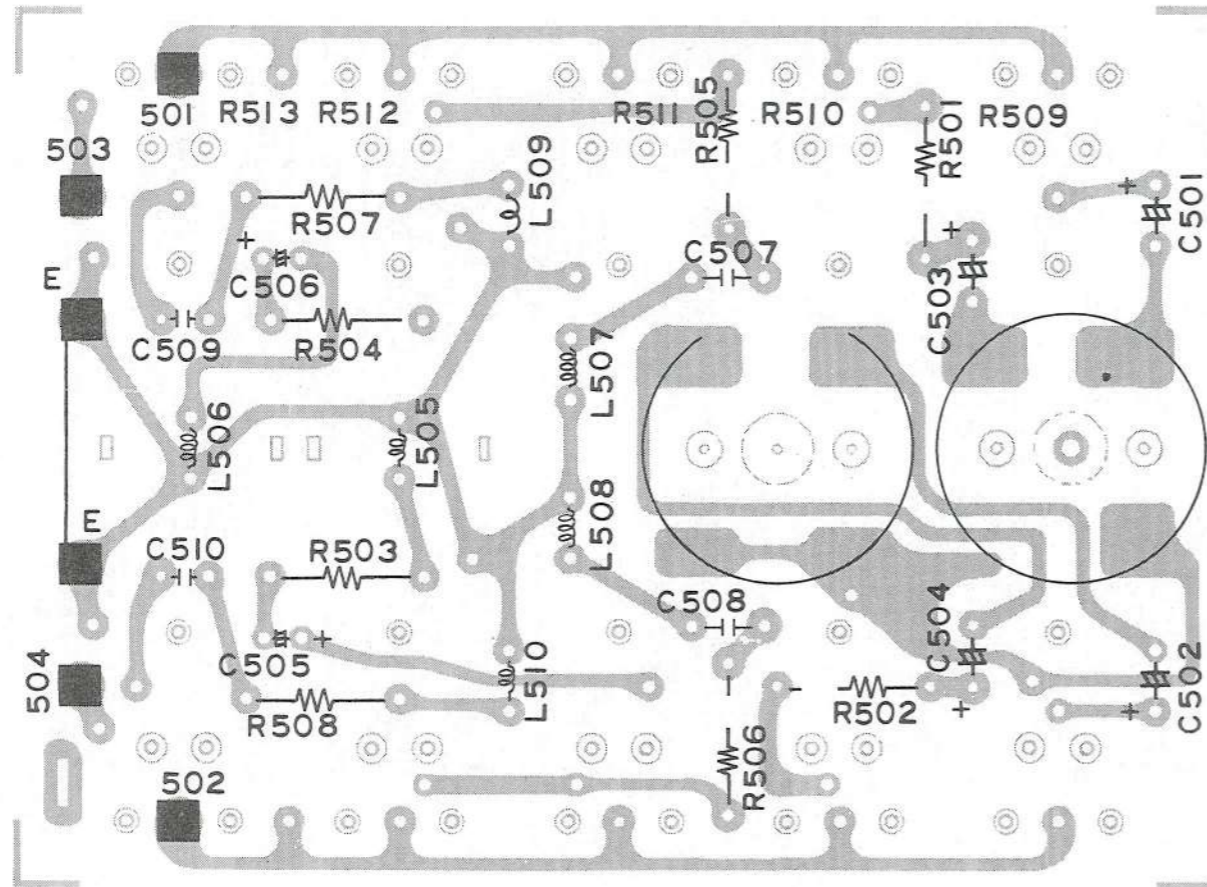

Fig. 28

TAC-303 (SEA CONTROL C.B. ASS'Y) PARTS LIST

Ref. No.	Parts No.	Description
• RESISTORS		
R501,502	QRD141J-331	Carbon 330Ω ±10% ¼W
R503,504	QRD141J-471	" 470Ω " "
R505~508	QRD141J-561	" 560Ω " "
R509~513	QVZ5010-001	Slide 50k (Special W)
• CAPACITORS		
C501,502	QEB41EM-106	Electrolytic 10μF ±20% 25V (LLC)
C503,504	QEB41EM-684	" 0.68μF " " "
C505,506	QEB41EM-224	" 0.22μF " " "
C507,508	QFM41HK-473	Mylar 0.047μF ±10% 50V
C509,510	QFM41HJ-103	" 0.01μF ±5% "
• INDUCTORS		
L501~504	E03108-11A	Choke 2H + 0.6H
L505,506	E0747-11	Ferri Inductor 100mH
L507,508	E0747-12	Ferri Inductor 22mH
L509,510	E0747-9	Ferri Inductor 10mH

TAC-306C (LAMP C.B. ASS'Y)

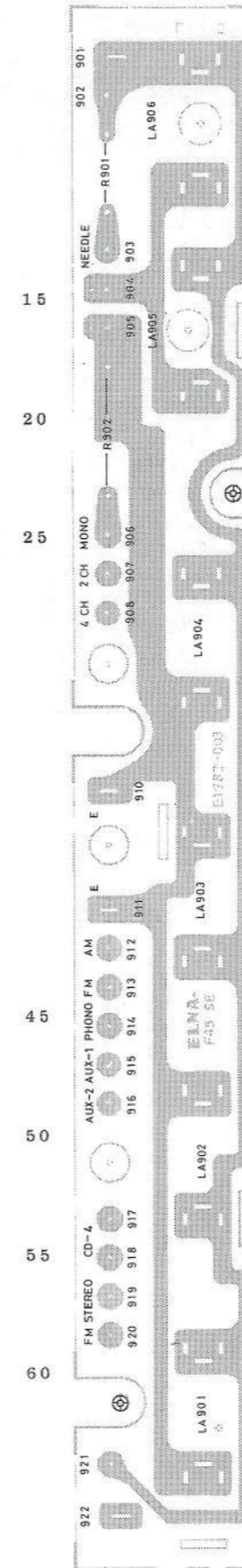

Fig. 29

TAC-306C (LAMP C.B. ASS'Y) PARTS LIST

Ref. No.	Parts No.	Description
• RESISTOR		
R901	E03347-101	Metal Film 100Ω ±10% 1W
• OTHER		
	E45524-001	Contact Clip
• MINI LAMP		
	QLP3104-104	12V 100mA
	QLP3104-101	6V 35mA (STEREO)
• CAPACITOR		
	QEW21CA-107	100μ/16V ±50% - 10%

TDM-22B (CD-4 DEMODULATOR C.B. ASS'Y)

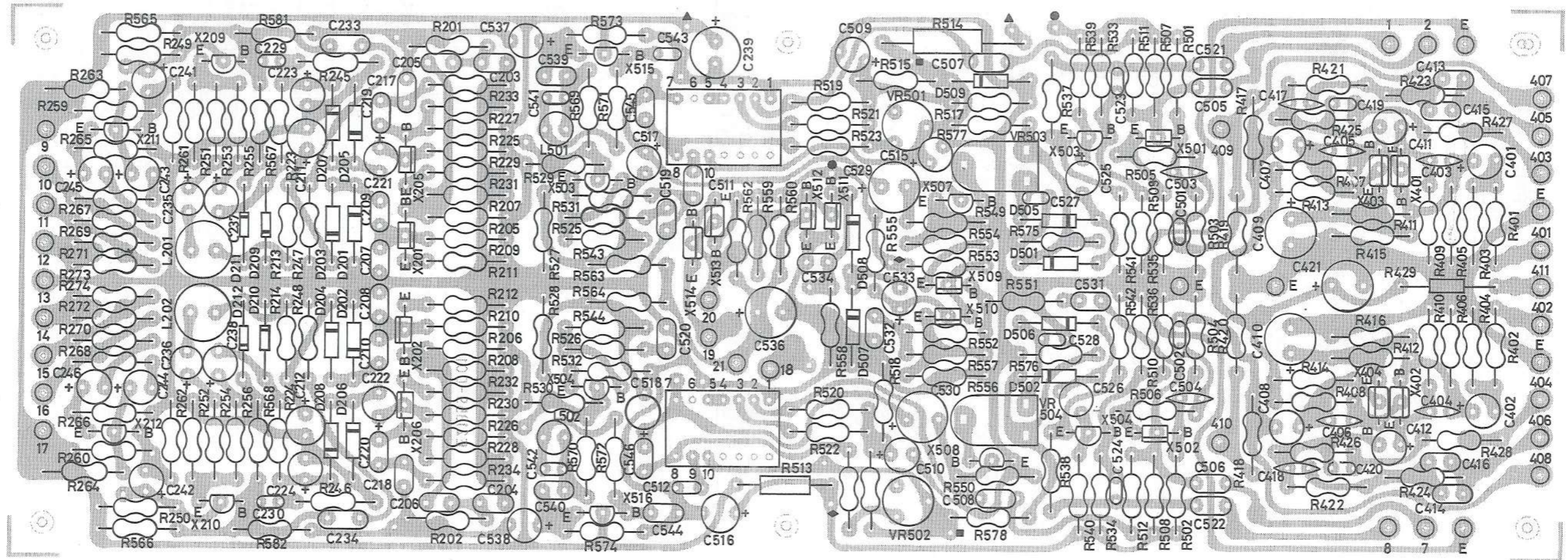

Fig. 30

TDM-22B (CD-4 DEMODULATOR C. B. ASS'Y) PARTS LIST

Ref. No.	Parts No.	Description
• TRANSISTORS		
X201,202	2SC458LD	Silicon (HITACHI)
X205,206	2SC458LD	" ( " )
X209~212	2SC871F or 2SC1312G	" (MITSUBISHI)
X401~404	2SC458ALGC	" (HITACHI)
X501,502	2SC458LD	" ( " )
X503,504	2SC871F or 2SC1312G	" (MITSUBISHI)
X505~513	2SC458LD	" (HITACHI)
X514	2SC1166Y	" (TOSHIBA)
X515,516	2SC871F or 2SC1312G	" (MITSUBISHI)
• DIODES		
D210~208	1N60	Germanium (TOSHIBA)
D209~212	1S2473	Silicon (TOYO DENGU)
D501,502	1S990	Silicon Varistor (JRC)
D505~508	1S990	" ( " )
D509	E0771-7	Zenner (JRC)
• IC		
IC501,502	CD-894	IC (SIGNETICS)

Ref. No.	Parts No.	Description
• INDUCTORS		
L201,202	E0747-17	Ferri Inductor 100mH
L501,502	E03587-103	" 10mH
• RESISTORS		
VR501,502	QVP4A0B-222	2.2kΩ (B) Mini Volume
VR503,504	QVP8A0B-024	20kΩ (B) " "
R201,202	QRD141J-822	Carbon 8.2kΩ ±5% ¼W
R205,206	QRD141J-824	" 820kΩ " "
R207,208	QRD141J-473	" 47kΩ " "
R209,210	QRD141J-562	" 5.6kΩ " "
R211,212	QRD141J-121	" 120Ω " "
R213,214	QRD141J-273	" 27kΩ " "
R223,224	QRD141J-273	" 27kΩ " "
R225,226	QRD141J-684	" 680kΩ " "
R227,228	QRD141J-473	" 47kΩ " "
R229,230	QRD141J-472	" 4.7kΩ " "
R231,232	QRD141J-121	" 120Ω " "
R233,234	QRD141J-153	" 15kΩ " "
R245,246	QRD141J-153	" 15kΩ " "



Ref. No.	Parts No.	Description			
R247,248	QRD141J-682	Carbon	6.8kΩ	±5%	¼W
R249,250	QRD141J-333	"	33kΩ	"	"
R251,252	QRD141J-332	"	3.3kΩ	"	"
R253,254	QRD141J-681	"	680Ω	"	"
R255,256	QRD141J-331	"	330Ω	"	"
R259,260	QRD141J-474	"	470kΩ	"	"
R261,262	QRD141J-224	"	220kΩ	"	"
R263~266	QRD141J-102	"	1kΩ	"	"
R267~274	QRD141J-103	"	10kΩ	"	"
R401,402	QRD141J-222	"	2.2kΩ	"	"
R403,404	QRD141J-124	"	120kΩ	"	"
R405,406	QRD141J-564	"	560kΩ	"	"
R407,408	QRD141J-334	"	330kΩ	"	"
R409,410	QRD141J-471	"	470Ω	"	"
R411,412	QRD141J-474	"	470kΩ	"	"
R413,414	QRD141J-103	"	10kΩ	"	"
R415,416	QRD141J-561	"	560Ω	"	"
R417,418	QRD141J-682	"	68kΩ	"	"
R419,420	QRD141J-122	"	1.2kΩ	"	"
R421,422	QRD141J-183	"	18kΩ	"	"
R423,424	QRD141J-224	"	220kΩ	"	"
R429	QRC121K-181	Composition	180Ω	±10%	"
R501,502	QRD141J-334	Carbon	330kΩ	±5%	"
R503,504	QRD141J-223	"	22kΩ	"	"
R505,506	QRD141J-392	"	3.9kΩ	"	"
R507,508	QRD141J-472	"	4.7kΩ	"	"
R509,510	QRD141J-181	"	180Ω	"	"
R511,512	QRD141J-153	"	15kΩ	"	"
R513	QRG011K-681	Oxide Metal	680Ω	±10%	1W
R514	QRG021K-391	"	390Ω	"	2W
R515~518	QRD141J-103	Carbon	10kΩ	±5%	¼W
R519~522	QRD141J-561	"	560Ω	"	"
R523,524	QRD141J-272	"	2.7kΩ	"	"
R525,526	QRD141J-182	"	1.8kΩ	"	"
R527,528	QRD141J-683	"	68kΩ	"	"
R529,530	QRD141J-822	"	8.2kΩ	"	"
R531,532	QRD141J-152	"	1.5kΩ	"	"
R533,534	QRD141J-334	"	330kΩ	"	"
R535,536	QRD141J-183	"	18kΩ	"	"
R537,538	QRD141J-682	"	6.8kΩ	"	"
R539,540	QRD141J-822	"	8.2kΩ	"	"
R541,542	QRD141J-151	"	150Ω	"	"
R543,544	QRD141J-123	"	12kΩ	"	"
R549,550	QRD141J-472	"	4.7kΩ	"	"
R551	QRD141J-563	"	56kΩ	"	"
R552	QRD141J-683	"	68kΩ	"	"
R553	QRD141J-123	"	12kΩ	"	"
R554	QRD141J-331	"	330Ω	"	"
R555	QRD141J-472	"	4.7kΩ	"	"
R556	QRD141J-681	"	680Ω	"	"
R557	QRD141J-273	"	27kΩ	"	"
R558	QRD141J-183	"	18kΩ	"	"
R559,560	QRD141J-273	"	27kΩ	"	"
R562	QRD141J-333	"	33kΩ	"	"
R563,564	QRD141J-274	"	270kΩ	"	"
R565,566	QRD141J-474	"	470kΩ	"	"
R567,568	QRD141J-473	"	47kΩ	"	"
R569,570	QRD141J-682	"	6.8kΩ	"	"
R571,572	QRD141J-102	"	1kΩ	"	"

Ref. No.	Parts No.	Description			
R573,574	QRD141J-123	Carbon	1.2kΩ	±5%	¼W
R575,576	QRD141J-821	"	820Ω	"	"
R577,578	QRD141J-472	"	4.7kΩ	"	"
R581,582	QRD141J-104	"	100kΩ	"	"
• CAPACITORS					
C203,204	QFM41HK-223	Mylar	0.022μF	±10%	50V
C205,206	QFM41HK-273	"	0.027μF	"	"
C207,208	QFM41HK-223	"	0.022μF	"	"
C209,210	QFM41HK-683	"	0.068μF	"	"
C211,212	QEW41VA-475	Electrolytic	4.7μF	+100% - 0%	35V
C217,218	QFM41HK-822	Mylar	0.0082μF	±10%	50V
C219,220	QFM41HK-392	"	0.0039μF	"	"
C221,222	QEW41HA-474	Electrolytic	0.47μF	+100% - 0%	50V
C223,224	QEW41HA-105	"	1μF	+100% - 0%	"
C229,230	QFM41HK-332	Mylar	0.0033μF	±10%	50V
C233,234	QFM41HK-823	"	0.082μF	"	"
C235,236	QEB41EM-684	Electrolytic	0.68μF	±20%	25V(LLC)
C237,238	QEB41EM-224	"	0.22μF	"	"
C239	QEW41HA-106	Electrolytic	10μF	+100% - 0%	50V
C241,242	QEW41HA-105	"	1μF	+100% - 0%	"
C243~246	QEW41HA-475	"	4.7μF	+100% - 0%	"
C401,402	QEB41EM-105	Electrolytic	1μF	±20%	25V (LLC)
C403,404	QCS11HJ-331	Ceramic	330pF	±5%	50V
C405,406	QCS11HJ-390	"	39pF	±5%	50V
C407,408	QEW41HA-475	Electrolytic	4.7μF	+100% - 0%	50V
C409,410	QEW41AA-107	"	100μF	+100% - 0%	10V
C411,412	QEW41EA-106	"	10μF	+100% - 0%	25V
C413,414	QFM41HJ-153	Mylar	0.015μF	±5%	50V
C415,416	QFM41HJ-332	"	0.0033μF	±5%	50V
C421	QEW41HA-107	Electrolytic	100μF	+100% - 0%	50V
C501,502	QFM41HK-102	Mylar	0.001μF	±10%	50V
C503,504	QCS11HJ-471	Ceramic	470pF	±5%	50V
C505,506	QFM41HK-153	Mylar	0.015μF	±10%	50V
C507,508	QFM41HK-222	"	0.0022μF	±10%	50V
C509,510	QEW41HA-105	Electrolytic	1μF	+100% - 0%	50V
C511~514	QFM41HK-272	Mylar	0.0027μF	±10%	50V
C515	QEW41CA-106	Electrolytic	10μF	+100% - 0%	16V
C516	QEW41EA-106	"	10μF	+100% - 0%	25V
C517,518	QEW41HA-105	"	1μF	+100% - 0%	50V
C519,520	QFM41HK-153	Mylar	0.015μF	±10%	50V
C521,522	QFM41HK-122	"	0.0012μF	±10%	50V
C523,524	QFM41HK-102	"	0.001μF	±10%	50V
C525,526	QEW41HA-474	Electrolytic	0.47μF	+100% - 0%	50V
C527,528	QFM41HK-332	Mylar	0.0033μF	±10%	50V
C529,530	QEW41CA-336	Electrolytic	33μF	+100% - 0%	16V
C531	QFM41HK-222	Mylar	0.0022μF	±10%	50V
C532	QFM41HK-333	"	0.033μF	±10%	50V
C533	QEW41HA-474	Electrolytic	0.47μF	+100% - 0%	50V
C534	QFM41HK-473	Mylar	0.047μF	±10%	50V
C536	QEW41CA-336	Electrolytic	33μF	+100% - 0%	16V
C537,538	QEW41HA-475	"	4.7μF	+100% - 0%	50V
C539,540	QFM41HK-153	Mylar	0.015μF	±10%	50V
C541,542	QFM41HK-122	"	0.0012μF	±10%	50V
C543,544	QFM41HK-182	"	0.0018μF	±10%	50V
C545,546	QFM41HK-102	"	0.001μF	±10%	50V

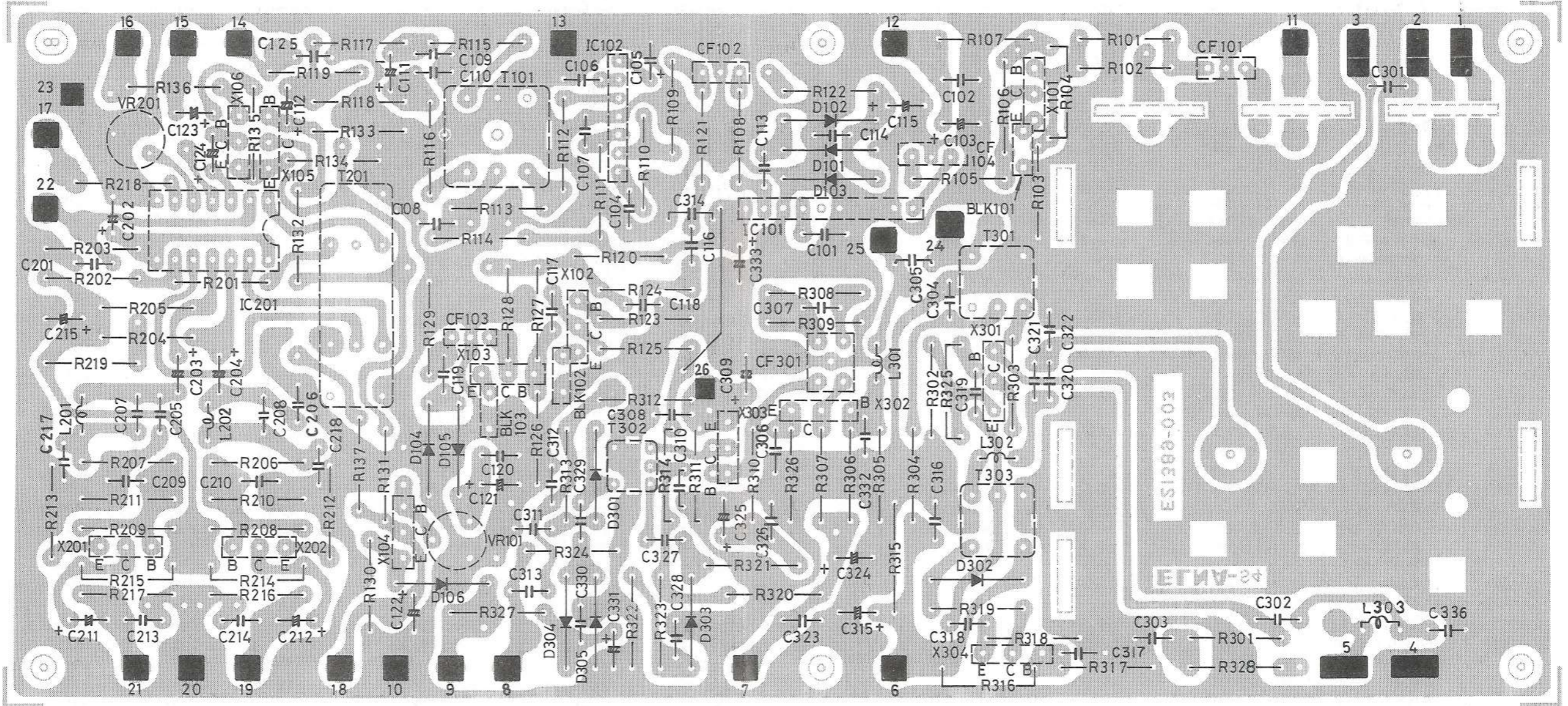

Fig. 31

## TFM207GUA3 (TUNER C.B. ASS'Y) PARTS LIST

Ref. No.	Parts No.	Description
• TRANSISTORS		
X101	2SC710B	Silicon Transistor (MITSUBISHI)
X102	2SC710C	" ( " )
X104	2SC711E	" ( " )
X105	2SC871F or 2SC1312G	" ( " )
X106	2SA628E	" ( " )
X201,202	2SC871F or 2SC1312G	" ( " )
X301	2SC710D	" ( " )
X302	2SC710C	" ( " )
X303	2SC829B	" (MATSUSHITA)
X304	2SC711E	" (MITSUBISHI)
• DIODES		
D101	1S188FM	Ge Diode (SANYO)
D104~106	1S188FM	" ( " )
D301~305	1S188FM	" ( " )
D306	1S2473	Silicon Diode (TOYO DENGU)
• IC		
IC101	E03450-005	IC (TAIYO)
IC102	TA7061AP	IC (TOSHIBA)
IC201	LA3301	IC (SANYO)
• RESISTORS		
R101	QRD141J-102	Carbon 1k $\Omega$ $\pm$ 5% $\frac{1}{4}$ W
R102	QRD141J-102	" 1k $\Omega$ " "
R103	QRD141J-332	" 3.3k $\Omega$ " "
R104	QRD141J-103	" 10k $\Omega$ " "
R105	QRD141J-151	" 150 $\Omega$ " "
R106	QRD141J-122	" 1.2k $\Omega$ " "
R107	QRD141J-100	" 10 $\Omega$ " "
R108,109	QRD141J-221	" 220 $\Omega$ " "
R110	QRD141J-471	" 470 $\Omega$ " "
R111	QRD141J-331	" 330 $\Omega$ " "
R112	QRD141J-102	" 1k $\Omega$ " "
R113	QRD141J-822	" 8.2k $\Omega$ " "
R114	QRD141J-100	" 10 $\Omega$ " "
R115,116	QRD141J-102	" 1k $\Omega$ " "
R117,118	QRD141J-472	" 4.7k $\Omega$ " "
R119	QRD141J-562	" 5.6k $\Omega$ " "
R120	QRD141J-0R0	Jumpping Resistor 0 $\Omega$
R122	QRD141J-0R0	" "
R123	QRD141J472	Carbon " 4.7k $\Omega$ $\pm$ 10% $\frac{1}{4}$ W
R124	QRD141J-123	" 12k $\Omega$ " "
R125	QRD141J-122	" 1.2k $\Omega$ " "
R129	QRD141J-222	" 2.2k $\Omega$ " "
R130	QRD141J-121	" 120 $\Omega$ " "
R131	QRD141J-103	" 10k $\Omega$ " "
R132	QRD141J-564	" 560k $\Omega$ " "
R133	QRD141J-334	" 330k $\Omega$ " "
R134,135	QRD141J-332	" 3.3k $\Omega$ " "
R136	QRD141J-104	" 100k $\Omega$ " "
R137	QRD141J-681	" 680 $\Omega$ " "
R140	QRD141J-472	" 4.7k $\Omega$ " "
R201	QRD141J-100	" 10 $\Omega$ " "
R202	QRD141J-391	" 390 $\Omega$ " "
R203	QRD141J-472	" 4.7k $\Omega$ " "
R204,205	QRD141J-332	" 3.3k $\Omega$ " "
R206,207	QRD141J-222	" 2.2k $\Omega$ " "
R208,209	QRD141J-334	" 330k $\Omega$ " "
R210,211	QRD141J-393	" 39k $\Omega$ " "
R212,213	QRD141J-821	" 820 $\Omega$ " "
R214,215	QRD141J-822	" 82k $\Omega$ " "
R216,217	QRD141J-104	" 100k $\Omega$ " "
R218	QRD141J-220	" 22 $\Omega$ " "
R219	QRD141J-221	" 220 $\Omega$ " "
R301	QRD141J-152	" 1.5k $\Omega$ " "

Ref. No.	Parts No.	Description			
R302	QRD141J-122	Carbon	1.2k $\Omega$	$\pm 5\%$	1/4W
R303	QRD141J-681	"	680 $\Omega$	"	"
R304	QRD141J-183	"	18k $\Omega$	"	"
R305	QRD141J-333	"	33k $\Omega$	"	"
R306	QRD141J-124	"	120k $\Omega$	"	"
R307	QRD141J-272	"	2.7k $\Omega$	"	"
R308	QRD141J-332	"	3.3k $\Omega$	"	"
R309	QRD141J-472	"	4.7k $\Omega$	"	"
R310	QRD141J-392	"	3.9k $\Omega$	"	"
R311	QRD141J-181	"	180 $\Omega$	"	"
R312	QRD141J-183	"	18k $\Omega$	"	"
R313	QRD141J-182	"	1.8k $\Omega$	"	"
R314	QRD141J-100	"	10 $\Omega$	"	"
R315	QRC121K-561	Composition	560 $\Omega$	$\pm 10\%$	1/2W
R316	QRD141J-473	Carbon	47k $\Omega$	$\pm 5\%$	1/4W
R317	QRD141J-682	"	6.8k $\Omega$	"	"
R318	QRD141J-102	"	1k $\Omega$	"	"
R319	QRD141J-181	"	180 $\Omega$	"	"
R320	QRD141J-100	"	10 $\Omega$	"	"
R321	QRD141J-182	"	1.8k $\Omega$	"	"
R322	QRD141J-681	"	680 $\Omega$	"	"
R323	QRD141J-332	"	3.3k $\Omega$	"	"
R324	QRD141J-124	"	120k $\Omega$	"	"
R325	QRD141J-6R8	"	6.8 $\Omega$	"	"
R326	QRD141J-471	"	470 $\Omega$	"	"
R327,328	QRD141J-152	"	1.5k $\Omega$	"	"
<b>• CAPACITORS</b>					
C101	QCZ0107-473	Ceramic	0.047 $\mu$ F	+80% - 20%	25V
C102	QCF11HP-223A	"	0.022 $\mu$ F	+100% - 0%	50V
C104	QCF11HP-223A	"	0.022 $\mu$ F	" "	"
C105	QCF11HP-223A	"	0.022 $\mu$ F	" "	25V
C107,108	QCF11HP-223A	"	0.022 $\mu$ F	" "	50V
C109,110	QCS11HJ-221	"	22pF	$\pm 5\%$	50V
C111,112	QEW41CA-106	Electrolytic	10 $\mu$ F	+100% - 0%	16V
C113	QCS11HJ-330	Ceramic	33pF	$\pm 5\%$	50V
C114	QCF11HP-223A	"	0.022 $\mu$ F	+100% - 0%	50V
C116	QCS11HJ-470	"	47pF	$\pm 5\%$	50V
C118~120	QCF11HP-223A	"	0.022 $\mu$ F	+100% - 0%	50V
C121	QEW41HA-474	Electrolytic	0.47 $\mu$ F	+100% - 0%	50V
C122	QEW41VA-475	"	4.7 $\mu$ F	" "	35V
C123,124	QEW41CA-106	"	10 $\mu$ F	" "	16V
C201	QFM41HK-272	Mylar	0.0027 $\mu$ F	$\pm 10\%$	50V
C202	QEW41HA-475	Electrolytic	4.7 $\mu$ F	+100% - 0%	50V
C203,204	QEB41EM-224	"	0.22 $\mu$ F	$\pm 20\%$	25V (LLC)
C205,206	QFM41HK-562	Mylar	0.0056 $\mu$ F	$\pm 10\%$	50V
C207,208	QFM41HJ-182	"	0.0018 $\mu$ F	$\pm 5\%$	"
C209,210	QFM41HK-153	"	0.015 $\mu$ F	$\pm 10\%$	"
C211,212	QEW41HA-105	Electrolytic	1 $\mu$ F	+100% - 0%	50V
C213,214	QFM41HK-102	Mylar	0.001 $\mu$ F	$\pm 10\%$	50V
C215	QEW41CA-476	Electrolytic	47 $\mu$ F	+100% - 0%	16V
C217,218	QFM41HK-562	Mylar	0.0056 $\mu$ F	$\pm 10\%$	50V
C302	QCZ0107-473	Ceramic	0.047 $\mu$ F	+80% - 20%	25V
C303~305	QCF11HP-223A	"	0.022 $\mu$ F	+100% - 0%	50V
C306	QCZ0107-473	"	0.047 $\mu$ F	+80% - 20%	25V
C307	QCS11HJ-121	"	120pF	$\pm 5\%$	50V
C308	QCF11HP-223A	"	0.022 $\mu$ F	+100% - 0%	50V
C309	QEW40JA-227	Electrolytic	220 $\mu$ F	+100% - 0%	10V
C310	QCF11HP-223A	Ceramic	0.022 $\mu$ F	+100% - 0%	50V
C311	QFM41HK-102	Mylar	0.001 $\mu$ F	$\pm 10\%$	50V
C312	QFM41HK-103	"	0.01 $\mu$ F	"	"
C313	QFM41HK-563	"	0.056 $\mu$ F	"	"
C314	QCZ0107-473	Ceramic	0.047 $\mu$ F	+80% - 20%	25V
C315	QEW41CA-106	Electrolytic	10 $\mu$ F	+100% - 0%	16V
C316	QCF11HP-223A	Ceramic	0.022 $\mu$ F	+100% - 0%	50V
C317	QCZ0107-473	Ceramic	0.047 $\mu$ F	+80% - 20%	25V
C318	QFM41HK-682	Mylar	0.0068 $\mu$ F	$\pm 10\%$	50V
C319	QCZ0107-473	Ceramic	0.047 $\mu$ F	+80% - 20%	25V
C320					
C321	QCS11HJ-361U	Ceramic	360pF	$\pm 5\%$	50V

Ref. No.	Parts No.	Description
C322	QCS11HJ-150U	Ceramic 15pF ±5% 50V
C323	QCF11HP-223A	" 0.022μF +100% -0% 50V
C324	QEW41CA-476	Electrolytic 47μF " " 16V
C325	QEW41AA-336	" 33μF " " 10V
C326	QCF11HP-223A	Ceramic 0.022μF +100% -0% 50V
C327	QCS11HJ-820U	" 82pF ±5% 50V
C328	QCF11HP-223A	" 0.022μF +100% -0% 50V
C329	QCS11HJ-391U	" 390pF ±5% 50V
C332	QCS11HJ-331	" 330pF " " "
C333	QEW41CA-107	Electrolytic 100μF +100% -0% 16V
C335	QEW41AA-336	" 33μF " " 10V
C336	QCS11HJ-151	Ceramic 150pF ±5% 50V
• MINI VOLUME		
VR201	QVP4A0B-102	1kΩ (B)
• CR BLOCKS		
BKL101	E03448-122	1.2kΩ + 0.022μF
BLK102	E03448-681	680Ω + 0.022μF
• COIL & TRANSFORMER		
T101	E03134-017	Detector Trans with Diode
T201	E03117-020	MPX Coil
L201	E03587-333	Choke Coil 33mH
L202	E03587-333	Choke Coil 33mH
T301	E03062-31	AM IFT
T302	E03062-33	AM IFT
T303	E03079-13	AM OSC Coil
L301	E03610-391	Choke Coil
L302	E03522-120K	Choke Coil
L303	E03520-3R3	Choke Coil
• CERAMIC FILTERS		
* CF101	E03357-002	10.7MHz (W or R or B) 10P12C
* CF102	E03357-002	10.7MHz ( " ) 10P12C
* CF103	E03476-003	10.7MHz ( " ) 10F12
* CF104	E03357-001	10.7MHz ( " ) CF10
CF301	E03399-001	455kHz
• FRONT END		
	E03546-003	FM Front End Ass'y

\* Please use the following parts together with a set of the same color such as Blue, Red, White.

CF101,102	E03357-002	Ceramic Filter
CF103	E03476-003	Ceramic Filter
CF104	E03357-001	Ceramic Filter
Blue	10.65MHz	
Red	10.70MHz	
White	10.75MHz	

## TFM-207GUA6 (TUNER C.B. ASS'Y) PARTS LIST

THIS C.B. ASS'Y IS SAME AS TFM-207GUA3 EXCEPT FOR FOLLOWING CAPACITORS ;

C.B. Ass'y	Ref. No.	Parts No.	Description
TFM-207GUA3	C209,210	QFM41HK-153	Mylar 0.015 $\mu$ F $\pm$ 10% 50V
TFM-207GUA6	C209,210	QFM41HK-822	Mylar 0.0082 $\mu$ F $\pm$ 10% 50V

(The FM DE-EMPHASIS of TFM-207GUA6 is 50 $\mu$ sec, and other specifications are same as TFM-207GUA3.)

### CHECK POINT AFTER REPAIR

Please make sure the following respect when repair is complete.

1. Each broadcasting frequency accords with dial scale accurately.
2. No abnormal oscillations occur in FM & AM reception.
3. Modulation hum is practically not appreciable.
4. Normal gain and output are obtained.
5. Both high and low range of audio frequency are not decreased exceptionally.
6. S.E.A. Controls operate normally.

### FUSE

	PARTS NAME	AMERICA	CANADA	EUROPE				AUSTRALIA	PACEX	OTHER AREA
				SEMKO AREA	SEV AREA	ENGLAND	OTHER AREA			
PRIMARY	FUSE	QMF61U1-3R0	QMF61U1-3R0 AND QMF63R1-3R3	QMF51A2-2R0	QMF60R1-1R8	QMF60R1-1R8	QMF60R1-1R8	QMF60R1-1R8 OR 3R3		
SECONDARY-1	FUSE	—	—	QMF51A2-4R0	—	—	—	—		
SECONDARY-2	FUSE	—	QMF63R1-R50	QMF51A2-R50	—	—	—	—		
SECONDARY-3	FUSE	—	—	QMF51A2-2R5	—	—	—	—		
ACCESSORY	FUSE	QMF61U1-3R0		—	QMF60R1-1R8	QMF60R1-1R8 AND 3R3	QMF60R1-1R8	QMF60R1-1R8 AND 3R3		

### ACCESSORY

PARTS NO.	PARTS NAME	QTY	DESCRIPTION
E30580-448A	INSTRUCTION BOOK	1	FOR INSTRUCTION BOOK FOR FUSE
E64207-001	ENVELOPE	1	
E64208-001	ENVELOPE	1	
E30539-424A	SCHEMATIC DIAGRAM	1	
E64103-001	POLISHING CLOTH	1	
4DE-205	TEST RECORD	1	

Ref. No.	Parts No.	Description			
R247,248	QRD141J-682	Carbon	6.8k $\Omega$	$\pm 5\%$	1/4W
R249,250	QRD141J-333	"	33k $\Omega$	"	"
R251,252	QRD141J-332	"	3.3k $\Omega$	"	"
R253,254	QRD141J-681	"	680 $\Omega$	"	"
R255,256	QRD141J-331	"	330 $\Omega$	"	"
R259,260	QRD141J-474	"	470k $\Omega$	"	"
R261,262	QRD141J-224	"	220k $\Omega$	"	"
R263~266	QRD141J-102	"	1k $\Omega$	"	"
R267~274	QRD141J-103	"	10k $\Omega$	"	"
R401,402	QRD141J-222	"	2.2k $\Omega$	"	"
R403,404	QRD141J-124	"	120k $\Omega$	"	"
R405,406	QRD141J-564	"	560k $\Omega$	"	"
R407,408	QRD141J-334	"	330k $\Omega$	"	"
R409,410	QRD141J-471	"	470 $\Omega$	"	"
R411,412	QRD141J-474	"	470k $\Omega$	"	"
R413,414	QRD141J-103	"	10k $\Omega$	"	"
R415,416	QRD141J-561	"	560 $\Omega$	"	"
R417,418	QRD141J-682	"	68k $\Omega$	"	"
R419,420	QRD141J-122	"	1.2k $\Omega$	"	"
R421,422	QRD141J-183	"	18k $\Omega$	"	"
R423,424	QRD141J-224	"	220k $\Omega$	"	"
R429	QRC121K-181	Composition	180 $\Omega$	$\pm 10\%$	"
R501,502	QRD141J-334	Carbon	330k $\Omega$	$\pm 5\%$	"
R503,504	QRD141J-223	"	22k $\Omega$	"	"
R505,506	QRD141J-392	"	3.9k $\Omega$	"	"
R507,508	QRD141J-472	"	4.7k $\Omega$	"	"
R509,510	QRD141J-181	"	180 $\Omega$	"	"
R511,512	QRD141J-153	"	15k $\Omega$	"	"
R513	QRG011K-681	Oxide Metal	680 $\Omega$	$\pm 10\%$	1W
R514	QRG021K-391	"	390 $\Omega$	"	2W
R515~518	QRD141J-103	Carbon	10k $\Omega$	$\pm 5\%$	1/4W
R519~522	QRD141J-561	"	560 $\Omega$	"	"
R523,524	QRD141J-272	"	2.7k $\Omega$	"	"
R525,526	QRD141J-182	"	1.8k $\Omega$	"	"
R527,528	QRD141J-683	"	68k $\Omega$	"	"
R529,530	QRD141J-822	"	8.2k $\Omega$	"	"
R531,532	QRD141J-152	"	1.5k $\Omega$	"	"
R533,534	QRD141J-334	"	330k $\Omega$	"	"
R535,536	QRD141J-183	"	18k $\Omega$	"	"
R537,538	QRD141J-682	"	6.8k $\Omega$	"	"
R539,540	QRD141J-822	"	8.2k $\Omega$	"	"
R541,542	QRD141J-151	"	150 $\Omega$	"	"
R543,544	QRD141J-123	"	12k $\Omega$	"	"
R549,550	QRD141J-472	"	4.7k $\Omega$	"	"
R551	QRD141J-563	"	56k $\Omega$	"	"
R552	QRD141J-683	"	68k $\Omega$	"	"
R553	QRD141J-123	"	12k $\Omega$	"	"
R554	QRD141J-331	"	330 $\Omega$	"	"
R555	QRD141J-472	"	4.7k $\Omega$	"	"
R556	QRD141J-681	"	680 $\Omega$	"	"
R557	QRD141J-273	"	27k $\Omega$	"	"
R558	QRD141J-183	"	18k $\Omega$	"	"
R559,560	QRD141J-273	"	27k $\Omega$	"	"
R562	QRD141J-333	"	33k $\Omega$	"	"
R563,564	QRD141J-274	"	270k $\Omega$	"	"
R565,566	QRD141J-474	"	470k $\Omega$	"	"
R567,568	QRD141J-473	"	47k $\Omega$	"	"
R569,570	QRD141J-682	"	6.8k $\Omega$	"	"
R571,572	QRD141J-102	"	1k $\Omega$	"	"

# TDM-22 SCHEMATIC DIAGRAM

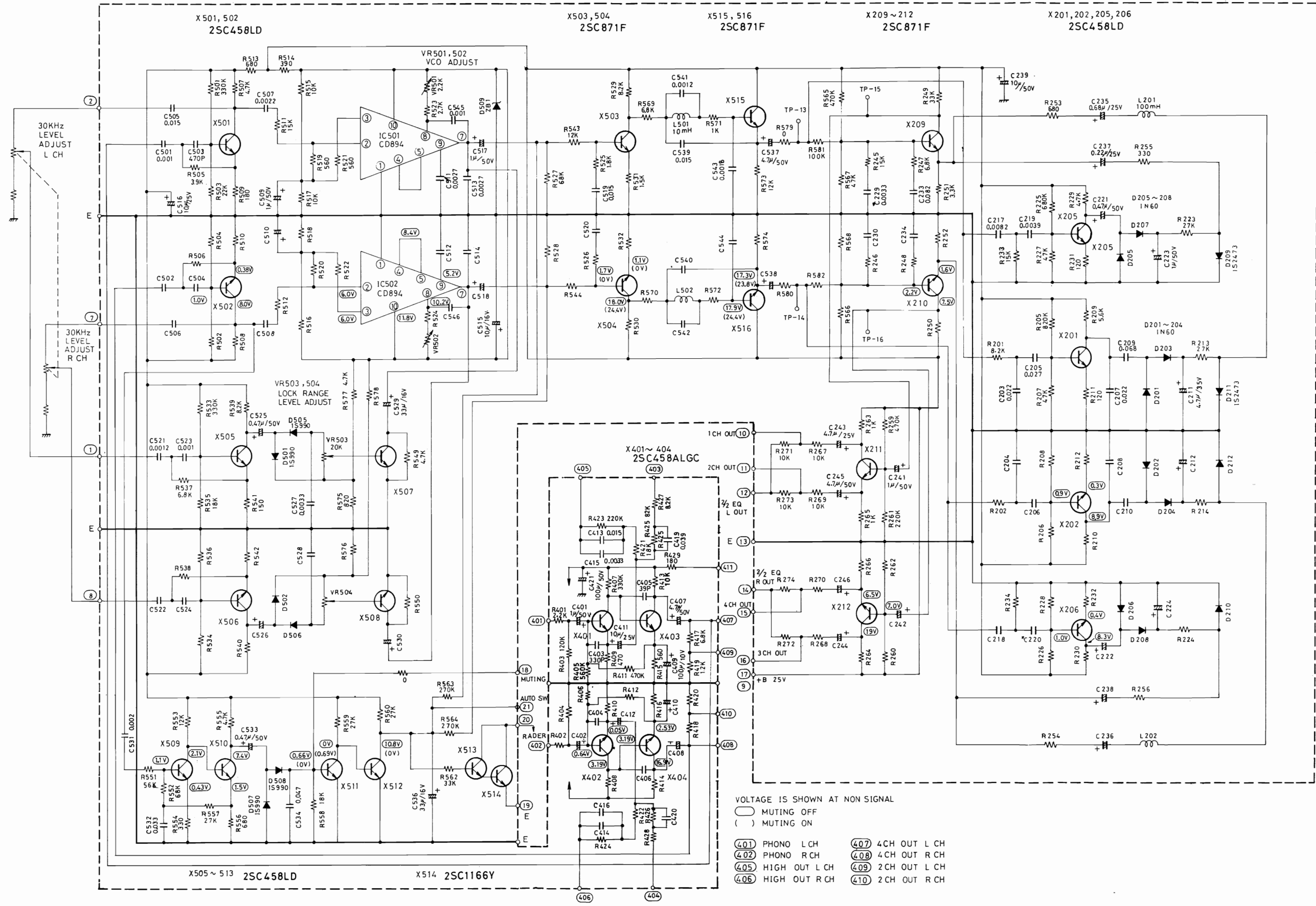

- VOLTAGE IS SHOWN AT NON SIGNAL
- ( ) MUTING OFF
  - ( ) MUTING ON
- |                     |                    |
|---------------------|--------------------|
| (401) PHONO L CH    | (407) 4CH OUT L CH |
| (402) PHONO R CH    | (408) 4CH OUT R CH |
| (405) HIGH OUT L CH | (409) 2CH OUT L CH |
| (406) HIGH OUT R CH | (410) 2CH OUT R CH |



# MODEL 4VR-5436X

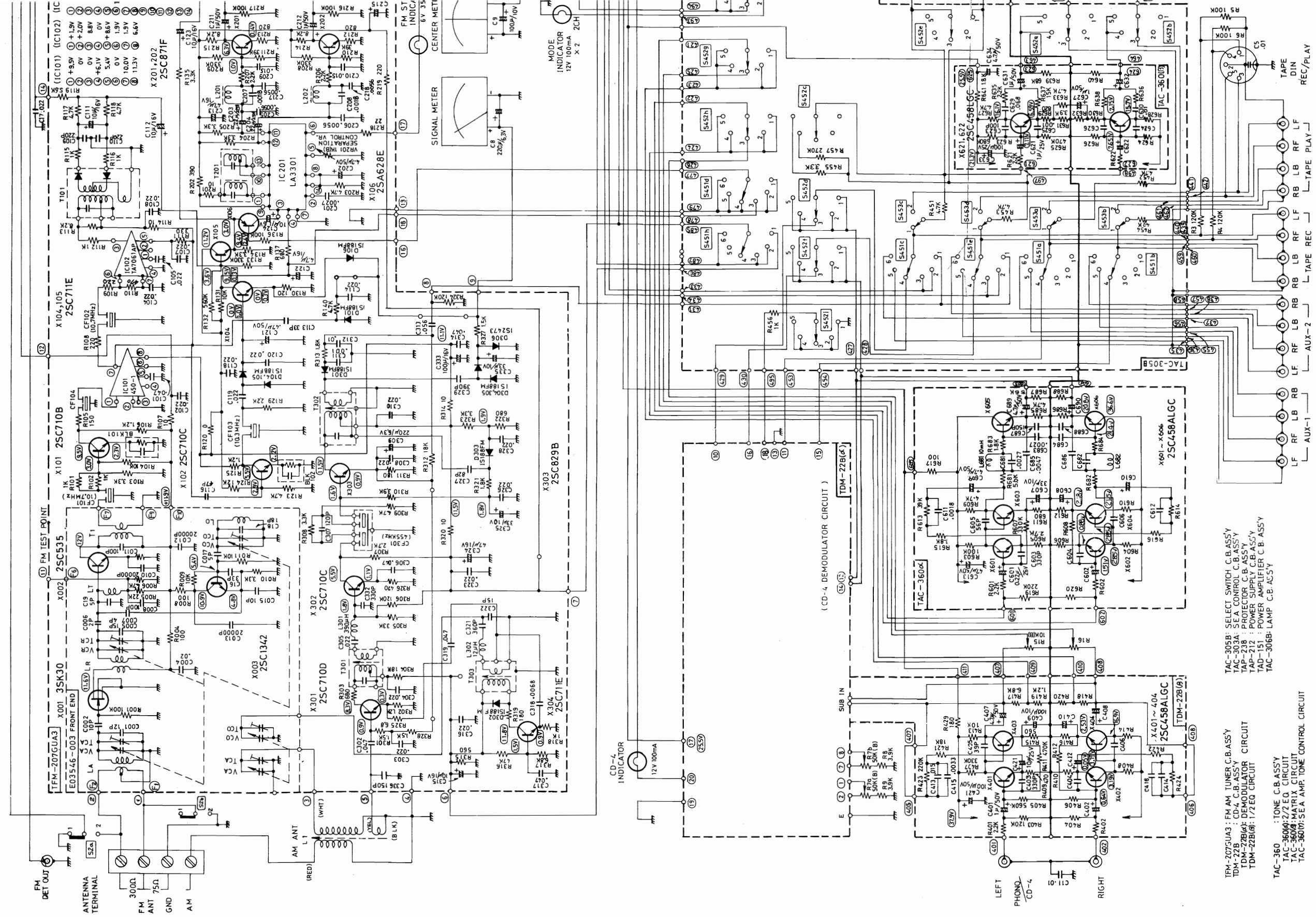

TAC-305B SELECT SWITCH C.B. ASSY  
 TAC-303A SEA CONTROL C.B. ASSY  
 TAC-238 PROTECTOR C.B. ASSY  
 TAP-238 POWER SUPPLIER C.B. ASSY  
 TAD-151 POWER SUPPLIER C.B. ASSY  
 TAC-306B LAMP C.B. ASSY

TFM-207GUA3 : FM AM TUNER C.B. ASSY  
 TDM-22B : CD-4 C.B. ASSY  
 TDM-22B(6) : DEMODULATOR CIRCUIT  
 TDM-22B(9) : 1/2 EQ CIRCUIT  
 TAC-360 : TONE C.B. ASSY  
 TAC-360(6) : 2/2 EQ. CIRCUIT  
 TAC-360(8) : MATRIX CIRCUIT  
 TAC-360(7) : SEA AMP. TONE CONTROL CIRCUIT

# WR-5436X SCHEMATIC DIAGRAM

\* This Schematic Diagram is for U.S.A.

Note: The primary circuit and parts of the other circuits are slightly different from this diagram in other areas, therefore please see the schematic diagrams shown on the back page.

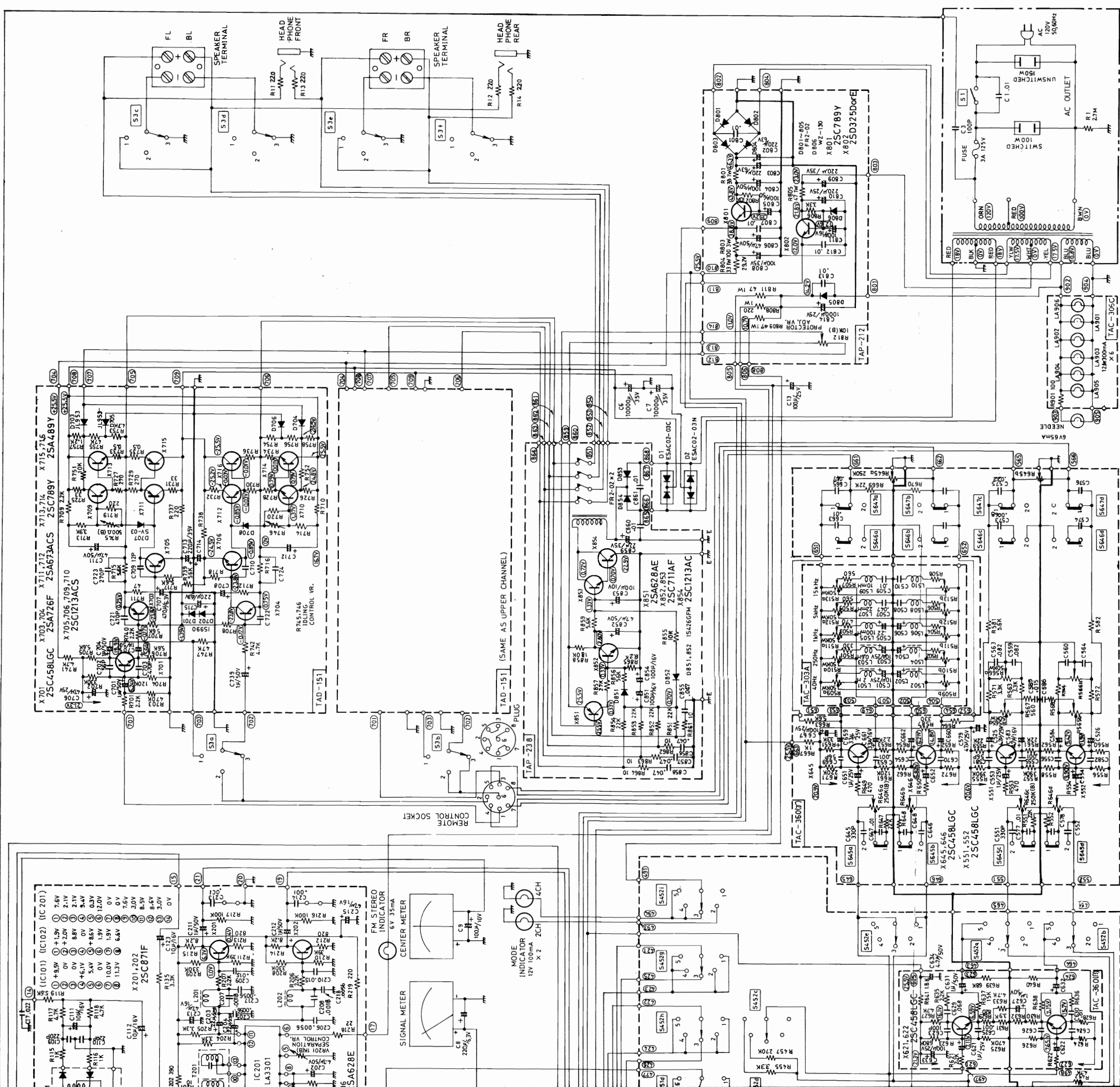

- LF: FRONT LEFT (CH-1)  
 RF: FRONT RIGHT (CH-3)  
 LB: BACK (REAR) LEFT (CH-2)  
 RB: BACK (REAR) RIGHT (CH-4)
- SWITCH  
 S1: POWER SW.  
 S2: FM INTERNAL ANT.  
 S3: SPEAKER SW.  
 S451: SOURCE SW.  
 S452: MODE SW.  
 S453: TAPE MONITOR SW.  
 S5451: 1-AM  
 S5452: 2 ON (PLAY BACK)  
 S5453: 3 FM MUTING  
 S5454: 4 CD-4/PHONO  
 S5455: 5 AUX-1  
 S5456: 6 AUX-2  
 S5457: 7 MONO  
 S5458: 8 CH DISCRETE  
 S5459: 9 MATRIX-1  
 S5460: 10 MATRIX-2
- VOLUME  
 R7: CD-4 30KHZ VR.  
 R15: CD-4 SEPARATION CONTROL VR. (LEFT)  
 R16: CD-4 SEPARATION CONTROL VR. (RIGHT)  
 R645: BALANCE VR.  
 R646: MASTER VR.  
 R566: TONE TREBLE CONTROL VR.  
 R508: SEA CONTROL VR. (40HZ)  
 R510: SEA CONTROL VR. (250HZ)  
 R511: SEA CONTROL VR. (1KHZ)  
 R512: SEA CONTROL VR. (5KHZ)  
 R513: SEA CONTROL VR. (15KHZ)

VOLTAGES ARE MEASURED WITH DC. VTVM.  
 AT NON SIGNAL INPUT.

Subject to change without notice  
 Printed in Japan E30539-424A,(O)

(E) FOR EUROPE

- TUNER C.B ASS'Y : TFM-207 GUA6
- PRIMARY CIRCUIT AND SECONDARY FUSES

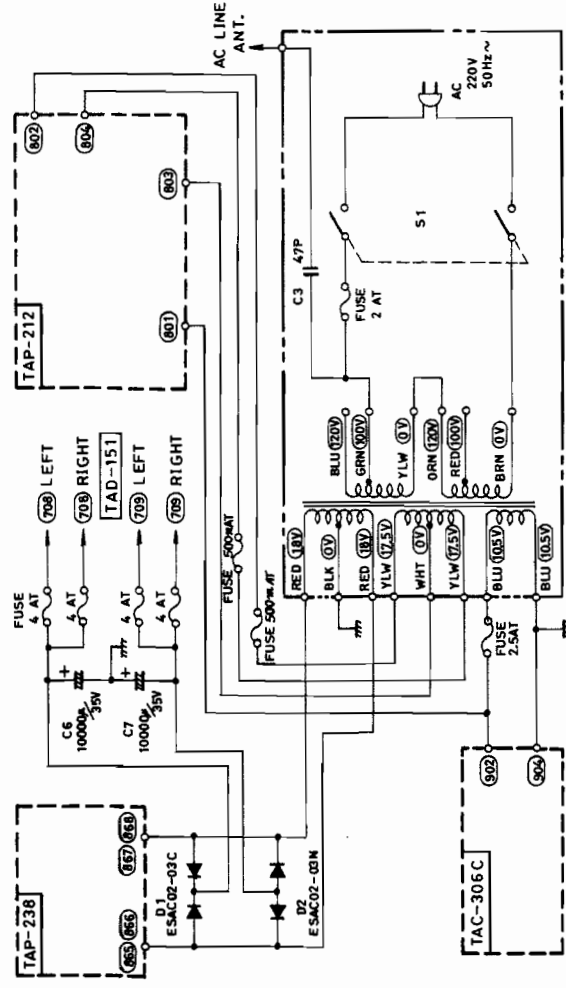

(A) FOR AUSTRALIA AND ENGLAND

- TUNER C.B ASS'Y : TFM-207 GUA6
- PRIMARY CIRCUIT

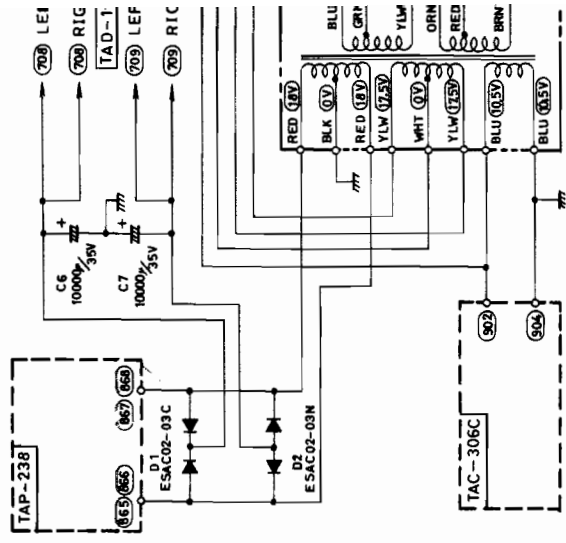

TUNER C.B ASS'Y

- TUNER C.B ASS'Y IS DISTINGUISHED TWO TYPES SUCH AS TFM-207 GUA3 AND TFM-207 GUA6.
- TFM-207 GUA6 IS SAME AS TFM-207 GUA3 EXCEPT C209 AND C210.

TFM-207 GUA6	FM DEEMPHASIS	C209, 210
TFM-207 GUA3	50μ SEC	0.0082μF
	75μ SEC	0.015 μF

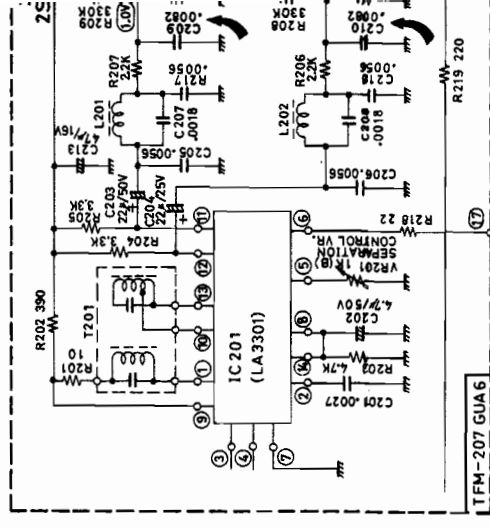

TDM-22B CD-4 DEMODULATOR

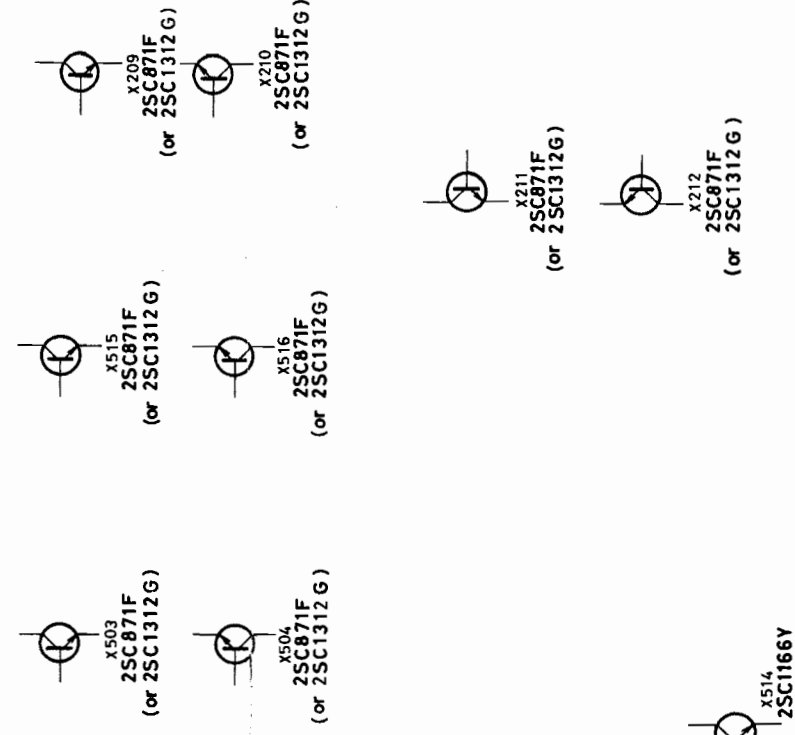
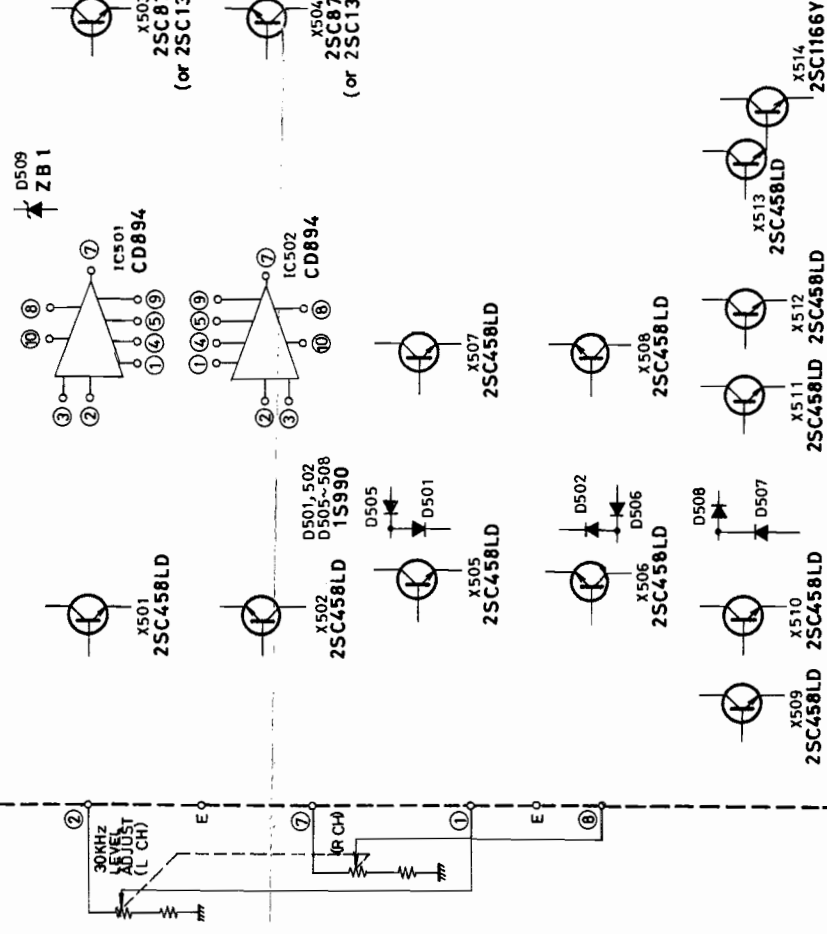

**AUSTRALIA AND ENGLAND**

ASS'Y : TFM-207 GUA6

CIRCUIT

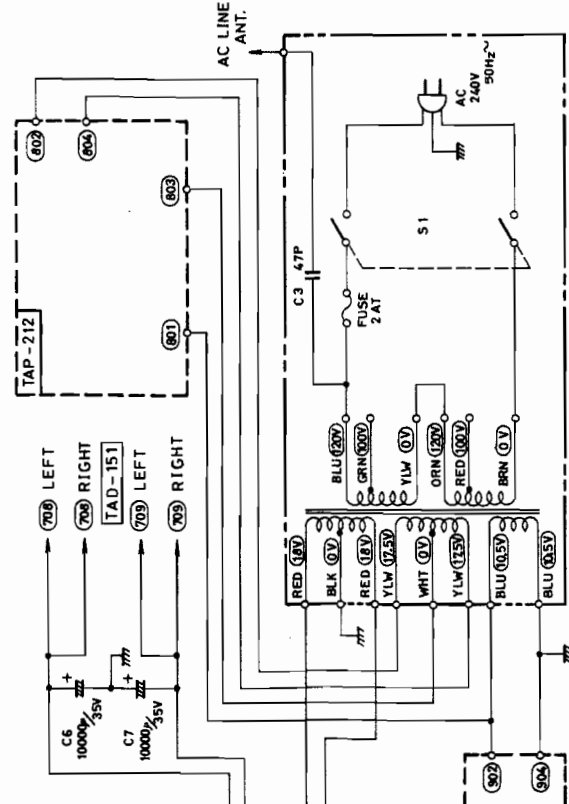

**(M) FOR CANADA**

■ TUNER C.B ASS'Y : TFM-207 GUA3  
 ■ PRIMARY CIRCUIT AND SECONDARY FUSES.

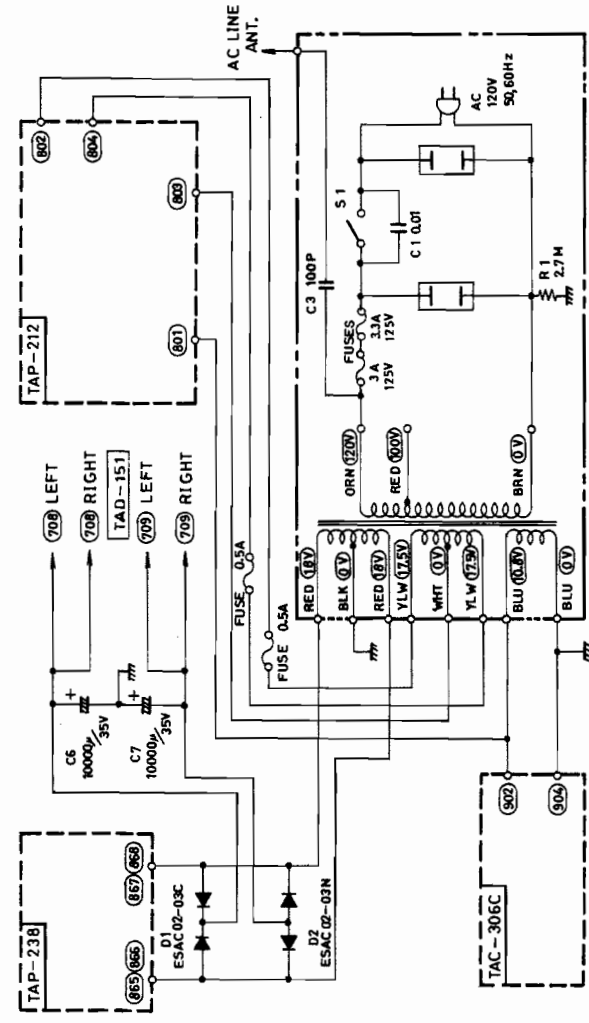

**(F) FOR EUROPE**

(P) FOR PACEX,NEX

(U) FOR OTHER COUNTRIES

■ TUNER C.B ASS'Y : (P)(U) TFM-207GUA3  
 ■ PRIMARY CIRCUIT (F) TFM-207GUA6

CIRCUIT

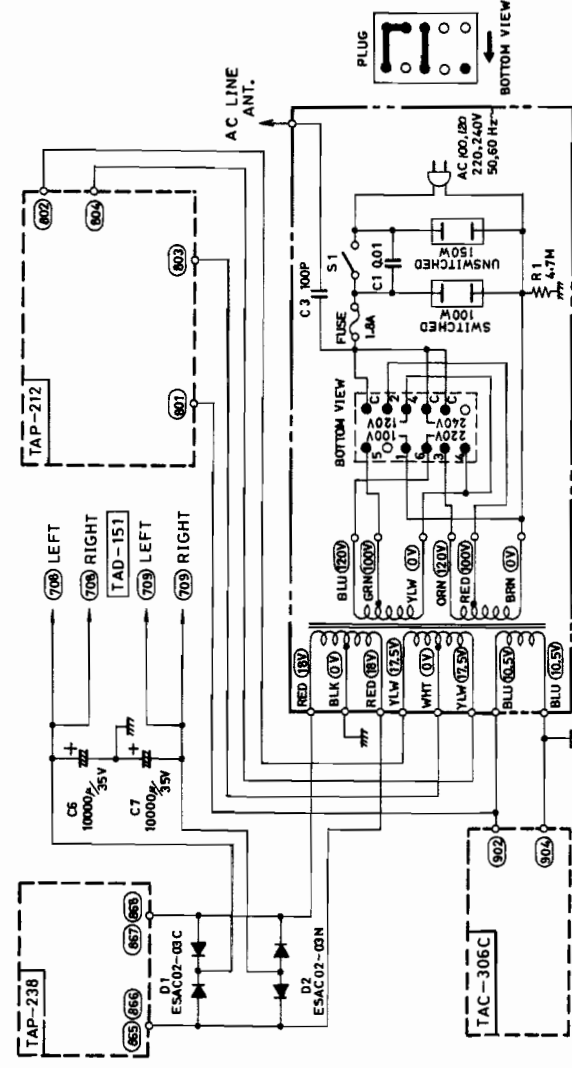

**X201, 202  
 2SC871F or 2SC1312G**

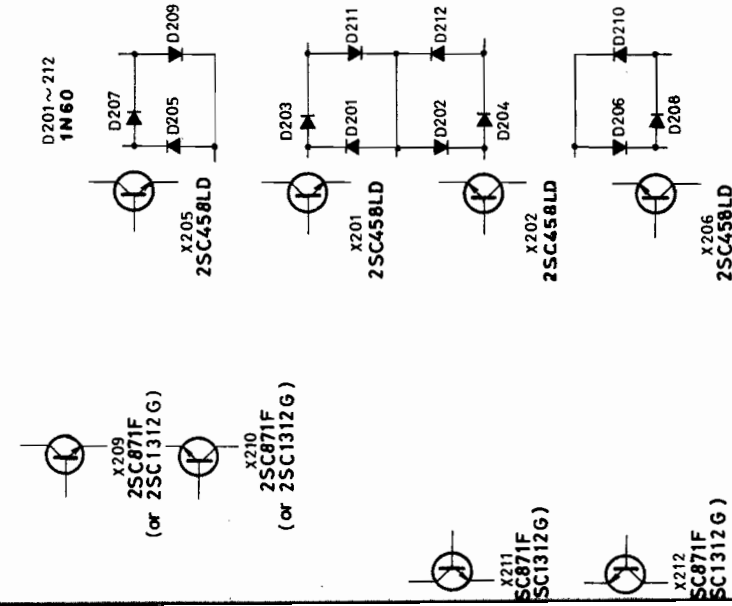
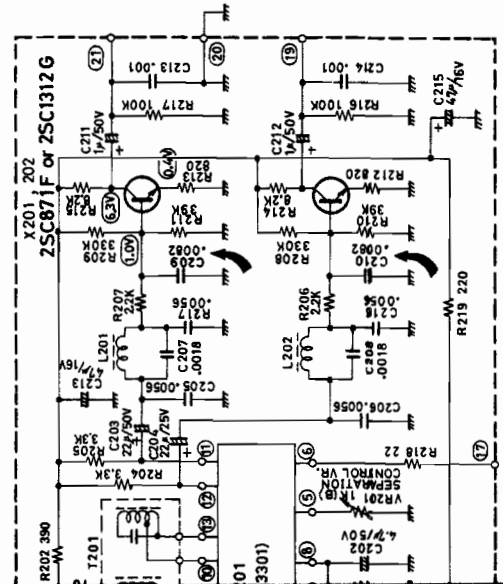

**IC201 (LA 3301)**

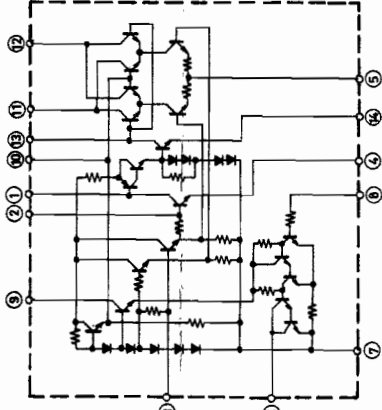

**IC102 (TA7061AP)**

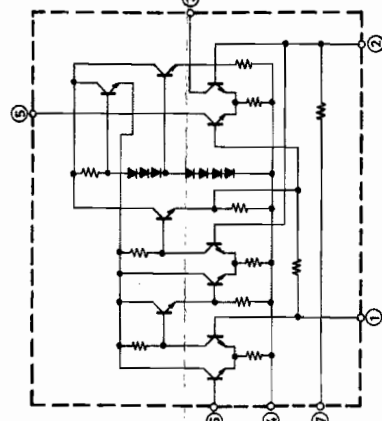

**IC101**

