

Service  
Service  
Service

AZ6812/17  
AZ6813/00/01/05/17



# Service Manual

COMPACT  
disc  
DIGITAL AUDIO

## Contents

Specification	2
Key-functions, shut off-functions, connections	3-4
Block diagram	5-6
Wiring diagram	7-8
Abbreviations	9
Service test program	10-11
Remote control - RC5 code	11
Service tools	11
Circuit diagram "SIGNAL & CONTROL PART"	12-14
Printed circuit board	15-16 / 19-20
Adjustment table	18
Circuit diagram "SERVO & LF-PART"	21-23
Exploded view	24-25
Mechanical partslist	26
Electrical partslist	27-29

(S)

### Varning!

Osynlig laserstrålning när denna del är öppnad och spärren är urkopplad. Betakta ej strålen.

(DK)

### Advarsel!

Usynlig laserstrålning ved åbning når sikkerhedsafbrydere er ude af funktion. Undgå udsættelse for stråling.

(SF)

### Varoitus!

Laite sisältää laserdiodin, joka lähettää näkymätöntä silmille vaarallista lasersäteilyä.

\*Pour votre sécurité, ces documents  
solvent être utilisés par des spécia-  
listes agréés, seuls habilités à réparer  
votre appareil en panne\*.

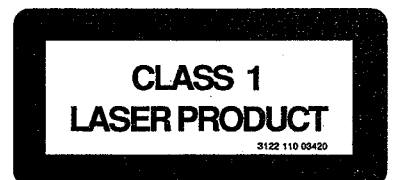

## SPECIFICATION

### GENERAL:

#### AC/DC-ADAPTOR

Type	: SBC 6608
Mains	: 220 V / 50 Hz 120 V / 60 Hz for /17
DC out	: 6,3 V stabilized / 400 mA max.
Power Consumption	: 8 W max.

#### BATTERY

Type	: 4 x R6 (6 V nom.)
Lifetime	: 6,5 hours at stationary mode
Power Consumption	: 1,5 W max. (500 $\mu$ W in stand by)

#### ACCU-PACKAGE

Type	: SBC 6411
Input voltage	: 6 - 7 V DC stabilized
Charging current	: 200 mA
Charging time	: 6 hours
Accu-output	: 4 V / 0,6 Ah

#### HEADPHONE

Type	: SBC 3124
Frequency response	: 20 - 20.000 Hz
Impedance	: 32 Ohms at 1kHz
Maximum power input	: 20mW

### CD-PART:

Frequency response	: 20 - 20.000 Hz $\pm$ 4 dB
S/N ratio	: 80 dB min.
THD	: 0,2 % max. at 1 kHz
Output power	: 2 x 20 mW max. into 32 Ohms
Line output level	: 0,6 V <sub>rms</sub> typ.
Channel difference	: 2 dB max.
Channel crosstalk	: -50 dB min. at 1 kHz
Deemphasis	: 0 or 15/50 $\mu$ s switched automat. by subcode on the disc
DAC	: Dual 16 bit, 4 f <sub>s</sub>

### LASER:

Output power	: 5 mW max. (3 mW typ.)
Wavelength	: 780 nm

#### GB WARNING

All ICs and many other semi-conductors are susceptible to electrostatic discharges (ESD). Careless handling during repair can reduce life drastically.

When repairing, make sure that you are connected with the same potential as the mass of the set via a wrist wrap with resistance. Keep components and tools also at this potential.

#### ESD



#### NL WAARSCHUWING

Alle IC's en vele andere halfgeleiders zijn gevoelig voor electrostatische ontladingen (ESD). Onzorgvuldig behandelen tijdens reparatie kan de levensduur drastisch doen verminderen. Zorg ervoor dat u tijdens reparatie via een polsband met weerstand verbonden bent met hetzelfde potentiaal als de massa van het apparaat.

Houd componenten en hulpmiddelen ook op ditzelfde potentiaal.

#### F ATTENTION

Tous les IC et beaucoup d'autres semi-conducteurs sont sensibles aux décharges statiques (ESD).

Leur longévité pourrait être considérablement écourtée par le fait qu'aucune précaution n'est prise à leur manipulation.

Lors de réparations, s'assurer de bien être relié au même potentiel que la masse de l'appareil et enfilez le bracelet serti d'une résistance de sécurité.

Veiller à ce que les composants ainsi que les outils que l'on utilise soient également à ce potentiel.

#### D WARNUNG

Alle ICs und viele andere Halbleiter sind empfindlich gegenüber elektrostatischen Entladungen (ESD).

Unvorsichtige Behandlung im Reparaturfall kann die Lebensdauer drastisch reduzieren.

Veranlassen Sie, dass Sie im Reparaturfall über ein Pulsarmband mit Widerstand verbunden sind mit dem gleichen Potential wie die Masse des Gerätes.

Bauteile und Hilfsmittel auch auf dieses gleiche Potential halten.

#### I AVVERTIMENTO

Tutti IC e parecchi semi-conduttori sono sensibili alle scariche statiche (ESD).

La loro longevità potrebbe essere fortemente ridotta in caso di non osservazione della più grande cautela alla loro manipolazione.

Durante le riparazioni occorre quindi essere collegato allo stesso potenziale che quello della massa dell'apparecchio tramite un braccialetto a resistenza.

Assicurarsi che i componenti e anche gli utensili con quali si lavora siano anche a questo potenziale.

#### GB

Safety regulations require that the set be restored to its original condition and that parts which are identical with those specified be used.

#### NL

Veiligheidsbepalingen vereisen, dat het apparaat in zijn oorspronkelijke toestand wordt teruggebracht en dat onderdelen, identiek aan de gespecificeerde worden toegepast.

#### F

Les normes de sécurité exigent que l'appareil soit remis à l'état d'origine et que soient utilisées les pièces de rechange identiques à celles spécifiées.

#### D

Bei jeder Reparatur sind die geltenden Sicherheitsvorschriften zu beachten. Der Originalzustand des Geräts darf nicht verändert werden für Reparaturen sind Original-Ersatzteile zu verwenden.

#### I

Le norme di sicurezza esigono che l'apparecchio venga rimesso nelle condizioni originali e che siano utilizzati pezzi di ricambio identici a quelli specificati.

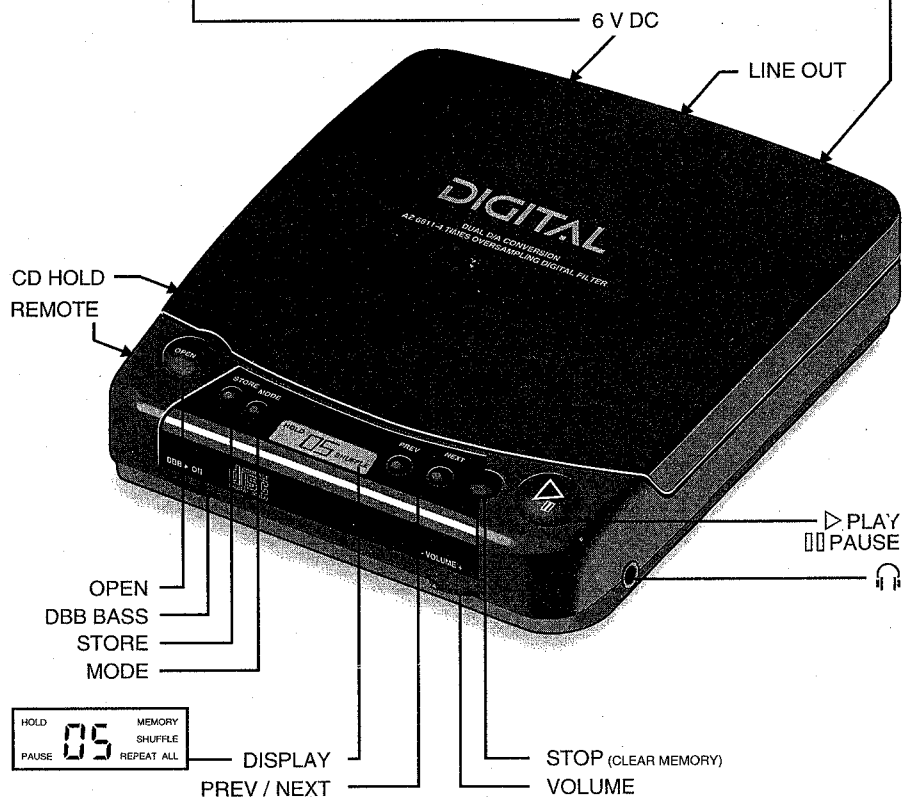
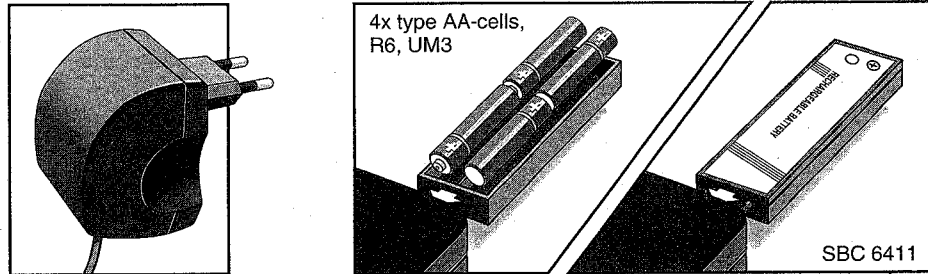

## KEY-FUNCTIONS, POWER ON / OFF, SHUT OFF FUNCTIONS, CONNECTIONS

KEY-FUNCTION	CONDITION	ACTION
PLAY	POWER OFF	Starts playing the first track
	POWER ON / STOP	Starts playing the first or the preselected title or the first programmed title or the first randomized title
	POWER ON / PLAY	Toggles between PLAY/PAUSE
STOP	PLAY	Set goes into STOP-mode
	STOP	Clears the program, "C" is shown for 500ms in the display
NEXT	STOP	Selects the next track which is shown in the display
	PLAY	Skips forward to next track
	PLAY / MEMORY	Skips to the next programmed title
	PLAY / SHUFFLE	Skips to the next shuffled title
	KEY DEPRESSED FOR MORE THAN 0.5s	Fast forward till the key is released, high speed after 6s
PREV	STOP	Selects the previous track which is shown in the display
	PLAY	If more than 2s of the current title are played the set plays this title again, else it skips back to the previous track
	PLAY / MEMORY	Skips to the previous programmed title if less than 2s
	PLAY / SHUFFLE	Plays this title again
	KEY DEPRESSED FOR MORE THAN 0.5s	Fast backward till the key is released, high speed after 6s
MODE	POWER ON	Scrolls the functions SHUFFLE, SHUFFLE REPEAT ALL, REPEAT ALL, REPEAT
STORE	POWER ON	Stores the selected title and shows "P" for 500ms in the display
	KEY DEPRESSED FOR MORE THAN 3s	Shows all programmed titles blinking in the display (DISPLAY MEMORY)
CD-FUNCTION	CONDITION	ACTION
CLOSE DOOR	POWER OFF	Power on - Start up - Read TOC - Stop - Show max. title
OPEN DOOR	POWER ON / OFF	Power off - Clear display - Clear TOC - Clear program
HOLD	POWER ON	All keys are ignored, HOLD flag is shown on the display.
	POWER OFF	It's not possible to switch on the set with the PLAY button to prevent unintentional power consumption.
SHUT OFF	STOP	The set shuts off after approx. 30s since the last physical action. If a program is stored the shut off time is 3min.
	AC/DC ADAPTOR CONNECTED & STOP	The set goes after 30s into STANDBY (display off, LF-part off, servo part off). The set can be "waked up" using the remote control.
CONNECTION		
6 V DC	Socket for the mains adaptor / battery charger SBC 6608	
PHONES	Headphone output	
LINE OUT	Linear output for hifi-systems	
REMOTE	Socket for the optional IR remote control SBC 6209 or the wired remote control SBC 6211	

BLOCKDIAGRAM

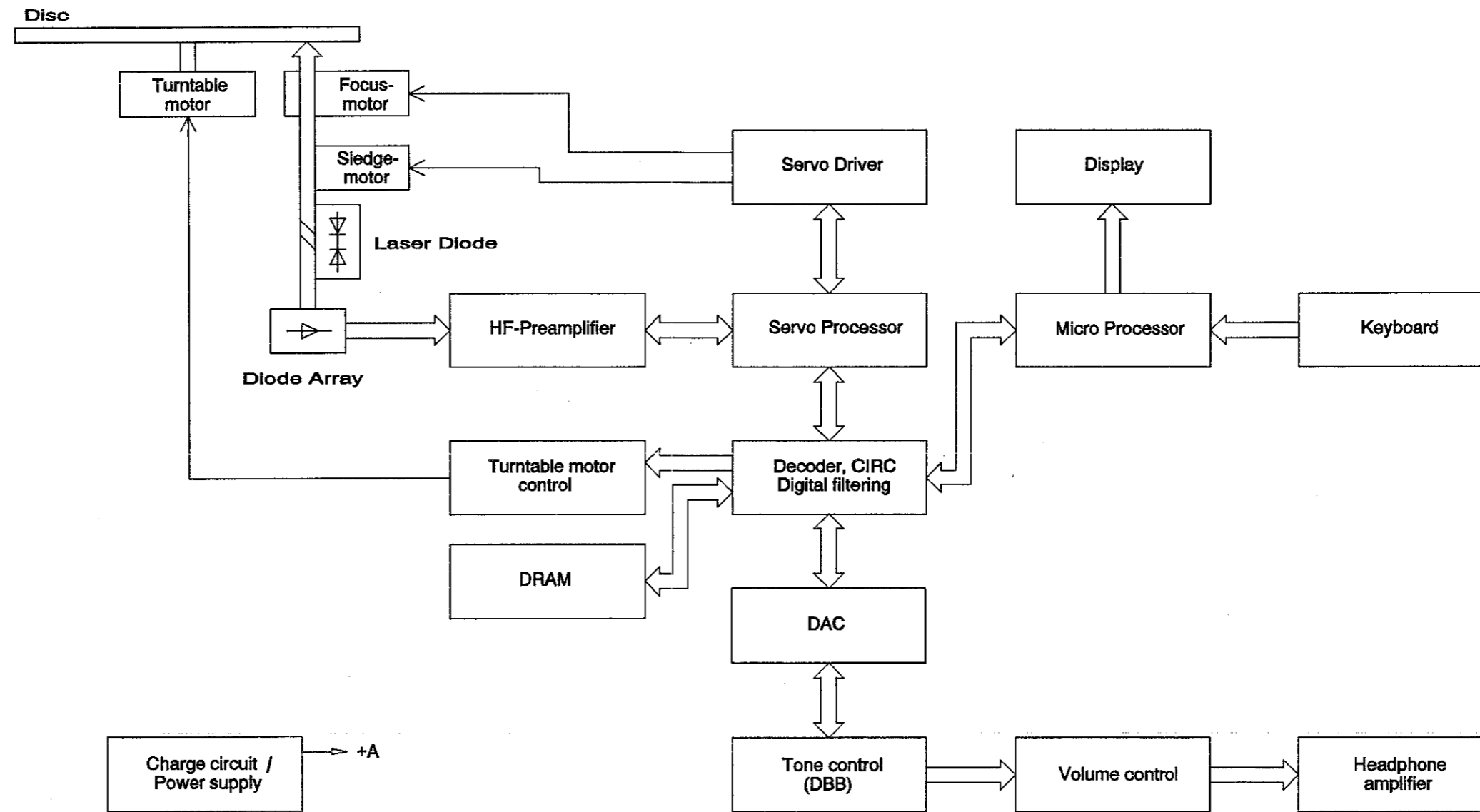

WIRING DIAGRAM

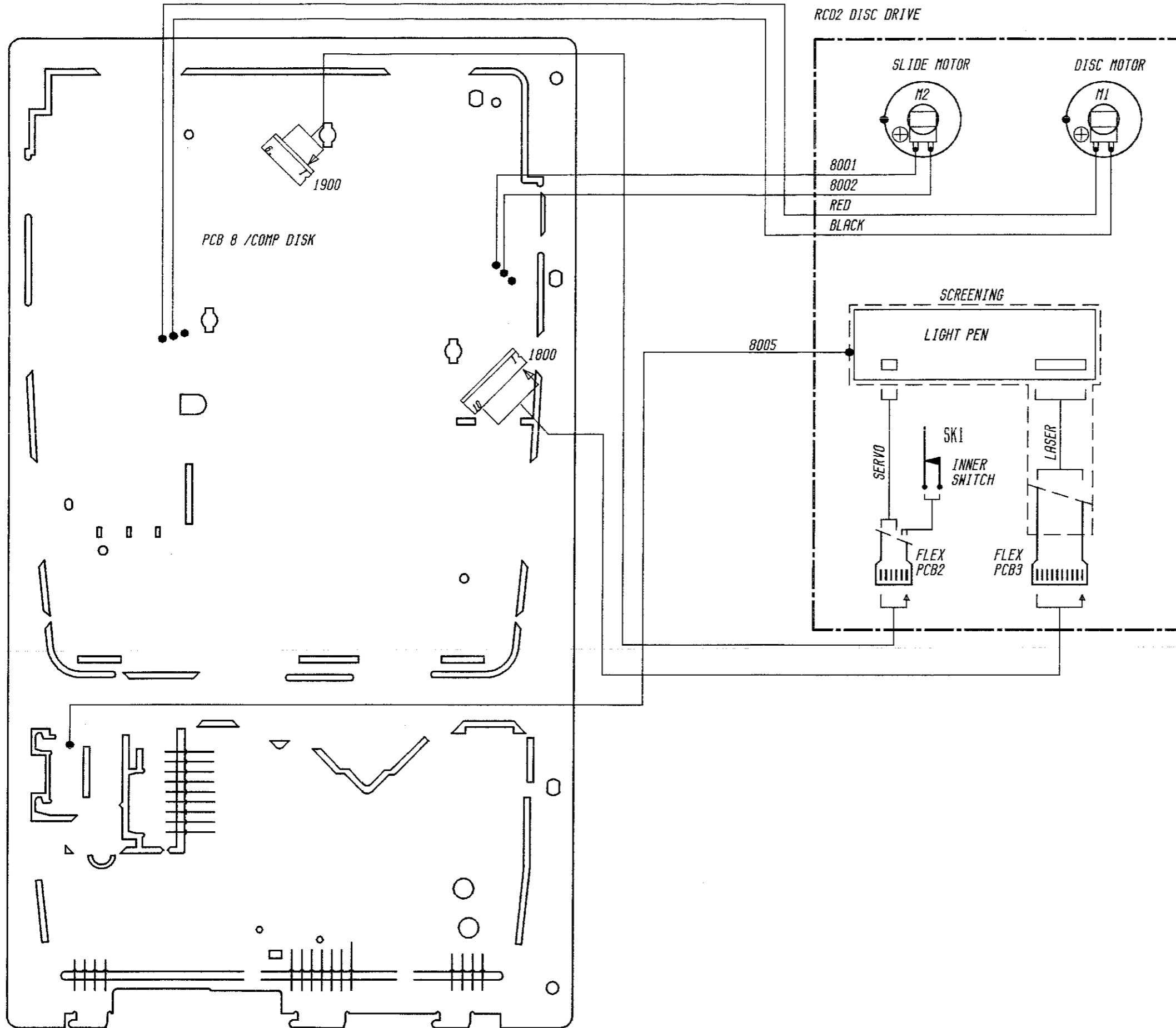

# ABBREVIATIONS

- A - F : Photodiode array outputs
- ACLR\* : μCOM interface register clear input
- ACLR\* : All clear input
- ACRCY : Clock accuracy input
- AOL : Analog output left channel
- AOR : Analog output right channel
- APTL : DAC sampling clock left channel
- APTR : DAC sampling clock right channel
- BCK : Bit clock input
- BIAS : Outputs reference voltage (VCC/2 at single supply voltage)
- C FSR : Connects the external capacitance for time constant of focus search
- C16MI : 1/2 divider input with internal feedback resistor
- C423 : Clock output 4,2336MHz
- C846 : Clock output 8,4672MHz
- C8MO : 1/2 divider output
- CAS\* : Column addr. strobe signal output to RAM
- COM : Common
- CRCF : Subcode Q CRC check flag output
- DASEL1-4 : Selection of DAC interface format
- DATA OUT : Inner condition output changed by command modes
- DLRCK : Left/right channel clock
- DM1 / DM2 : Turntable motor driving outputs
- DO1 : Dual DAC right channel serial data output
- DO2 : Dual DAC left channel serial data output
- DOBSEL : Data bit select (18 bit = "H")
- DOFK : Frame clock output 7,35kHz (duty = 50%)
- DOTX : Output of digital interface
- DRD : Disc rotation down signal output
- DSCK : Data shift clock to DAC
- EFFK : EFM frame clock output (duty = 50%)
- EFM : Eight to fourteen modulation
- EMP : Emphasis flag output (Emphasis = "H")
- EST1 : Error status1 (Error detected at C1-decoder)
- EST2 : Error status2 (Error to be interpolated detected at C2-decoder)
- FG : Focus gain switch output
- FS OUT : Focus servo amplifier output
- FS+ / FS- : Focus servo amplifier positive / negative input
- FSCK : Clock output 44,1kHz (f<sub>s</sub>)
- FSR IN : Focus search detector input
- GND : Ground 0V
- HF : High frequency signal input
- HF OK : HF OK signal input
- HFD\* : High frequency signal detection
- HFD\* : Outputs "H", when MR = "H" and tracking servo loop cuts off
- HOUT 2A/2B : Sledge motor driving PWM outputs
- HOUT 3A/3B : Track servo driving PWM outputs
- HOUT 4A/4B : Focus servo driving PWM outputs
- IREF : Current reference
- JMP : Outputs "H" under jump function
- JP1\*, JPI\* : 1 track jump control signal input (usually "H")
- LOCK/DRD : Lock status / Disc rotation down signal output
- LPF : PLL loop filter
- LRCK : Left/right channel clock to DAC or APTR clock
- MCK : μCOM interface shift clock input
- MLA\* : μCOM interface data latch clock input
- MR : Mirror detected signal input
- MSD : μCOM interface serial data input
- NC : No connection
- PWM1-2 : Turntable motor driving PWM outputs
- RAD0-7 : Address output 0-7 to RAM
- RAS\* : Row address strobe signal output to RAM
- RDB1-4 : Data input/output 1-4 to RAM
- SBCP : Subcode P channel output, P - W channel serial data output
- SBCQ : Subcode Q channel output
- SBCR : Subcode R channel output
- SBCS : Subcode S channel output
- SBCT : Subcode T channel output
- SBCU : Subcode U channel output
- SBCV : Subcode V channel output
- SBCW : Subcode W channel output
- SCCK : Shift clock input for serial subcode data output
- SCINT : Interrupt output of subcode Q
- SCOE1 : Enable input of subcode T-W channel output
- SCOE2 : Enable input of subcode P-S channel output
- SCOR : Subcode sync. output
- SHOCK : Shock detector signal input
- SQRCK : Subcode Q register
- SQRO : Subcode Q register output
- SS OUT : Sledge servo amplifier output
- SS+ / SS- : Sledge servo amplifier positive / negative input
- SYCLK : Frame lock status output (Lock = "H")
- TB : Tracking balance input
- TC IN : Track cross signal input
- TE IN : Track error signal input
- TE OUT : Track error amplifier output
- TE- : Track error amplifier negative input
- TEST1 : Test control input
- TG1 / TG2 : Tracking gain switch 1/2 output
- TLC : Output from slice level control
- TRHLD : Direct control pin of TS1 switch
- TS OUT : Track servo amplifier output
- TS+ / TS- : Track servo amplifier positive / negative input
- VCC : Positive supply voltage
- VDD : positive power supply
- VEE : Negative supply voltage
- VREF : Reference voltage
- VSS : Ground 0V
- WDCK : Word clock to DAC or APTL clock
- WE\* : Write enable output to RAM
- WS : Word select input
- XI : Crystal oscillator input with internal feedback resistor
- XO : Crystal oscillator output

\* LOG. "0" ACTIVE !

# SERVICE TEST PROGRAM

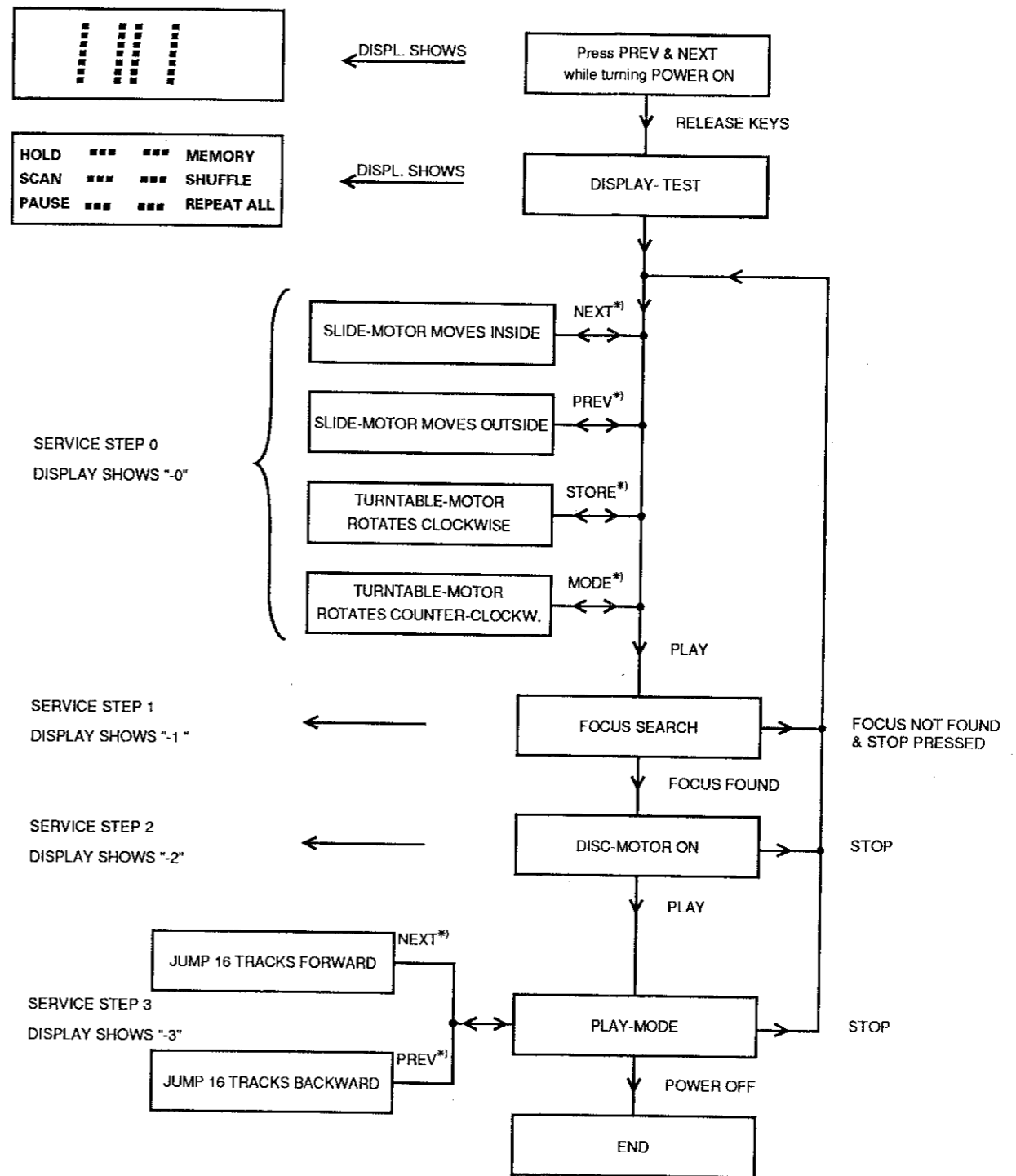

\*) HOLD KEY DEPRESSED

# SERVICE

## 1. PRELIMIN

To get into & NEXT de service mo till the keys and flags (h Also all sup

## 2. SERVICE

To get into movement checked by (After the 1' display sho NEXT - PREV - STORE - MODE - PLAY -

## 3. SERVICE

To get into press PLAY the unit star "high". In th jumps to s should mo measured a service step.

# REMOTE C

SYS	REC
COMMA	
0	
1	
2	
3	
4	
5	
6	
7	
8	
9	

# SERVICE TEST PROGRAM

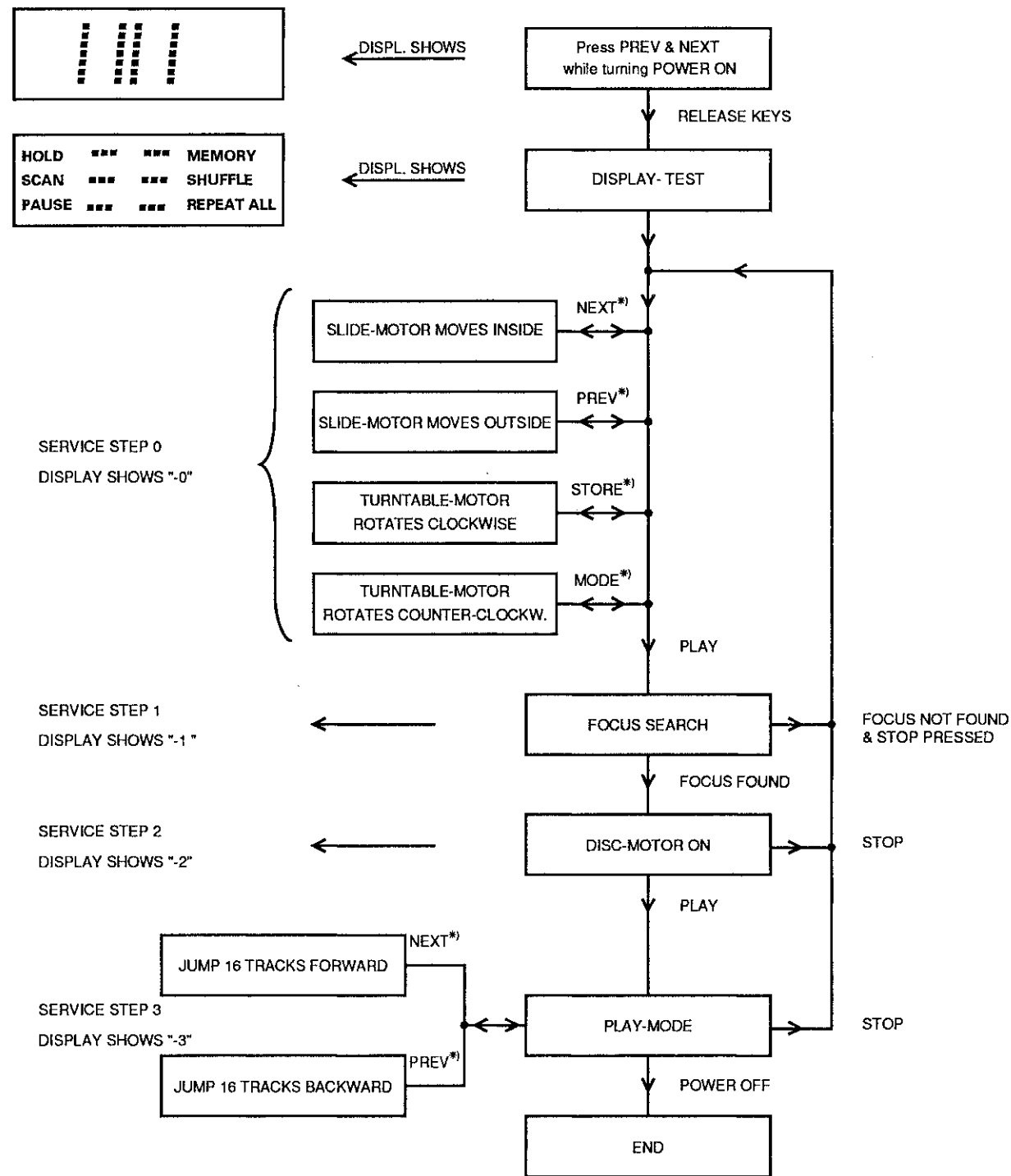

\*) HOLD KEY DEPRESSED

# SERVICE TEST PROGRAM

## 1. PRELIMINARY SETUP

To get into the service test program hold the keys PREV & NEXT depressed while turning POWER ON. When the service mode is entered all vertical segments are shown till the keys are released. Then all horizontal segments and flags (HOLD, SCAN, ...) are activated (see flow chart). Also all supply voltages are on, NF-mute is switched off.

## 2. SERVICE STEP 0 - MOTORTEST

To get into service step 0 fulfil preliminary setup. The movement of the slide- resp. turntable-motor can be checked by holding the corresponding key depressed (After the 1st press service step 0 has been entered - the display shows "-0"):

- NEXT - Slide motor moves inside
- PREV - Slide motor moves outside
- STORE - Turntable motor rotates clockwise
- MODE - Turntable motor rotates counter-clockwise

PLAY - Jump to service step 1

## 3. SERVICE STEP 1 - FOCUS SEARCH

To get into service step 1 fulfil preliminary setup and press PLAY. The display shows "-1". If a CD is inserted the unit starts to search the focus till DATA OUT becomes "high". In that case focus has been found and the unit jumps to service step 2. If no CD is inserted the lens should move up/down continuously. Signal 11 can be measured at pin 29 of servo-processor 7840. To return to service step 0 press STOP.

## 4. SERVICE STEP 2 - TURNTABLE MOTOR ON

Service step 2 can only be entered if a focus has been found. In that case the display shows "-2" and the turntable-motor starts rotation. With the PLAY key service step 3 can be entered, pressing STOP will return to service step 0.

## 5. SERVICE STEP 3 - PLAY MODE

The display shows "-3". The tracking is switched on and MUTE is released. Hold the following keys depressed and check their correct function:

- NEXT - Jump 16 tracks forward
- PREV - Jump 16 tracks backward

**NOTE:** - To leave the service test program it is necessary to disconnect the unit from the power supply.

- The door switch is ignored by software and therefore the door can be opened during the test procedure. This might be helpful to check the correct movement of the track-servo and the turntable-motor.

Attention: The laser beam is also kept emitting !!

## REMOTE CONTROL - RC5 CODE

SYSTEMCODES 20 AND 21 ARE RECOGNIZED (CD AND COMBI)	
COMMAND CODE	KEY
0...9	TRACKNUMBER DIRECT
11	DISPLAY MEMORY
28	SHUFFLE
29	REPEAT
32	NEXT
33	PREVIOUS
41	PROGRAM
48	PAUSE
50	REVIEW
52	CUE
53	PLAY
54	STOP
58	CLEAR PROGRAM

## SERVICE TOOLS

- TORX screwdriver set **4822 395 50145**
- Audio signal disc **4822 397 30184**
- Test discs 5 & 5A **4822 397 30096**
- 3" test disc **4822 397 30229**

CD DIGITAL SIGNAL & CONTROL PART

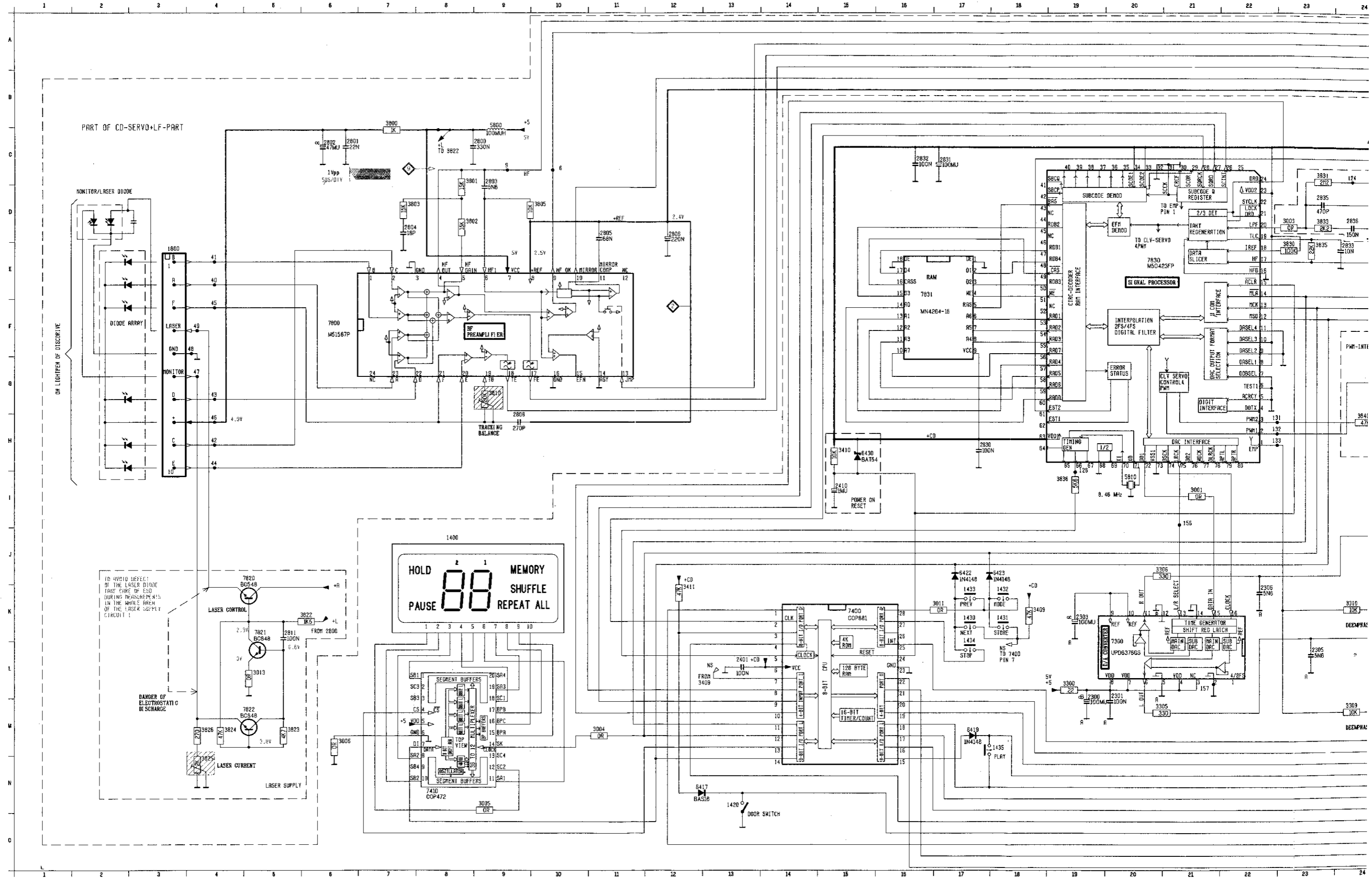

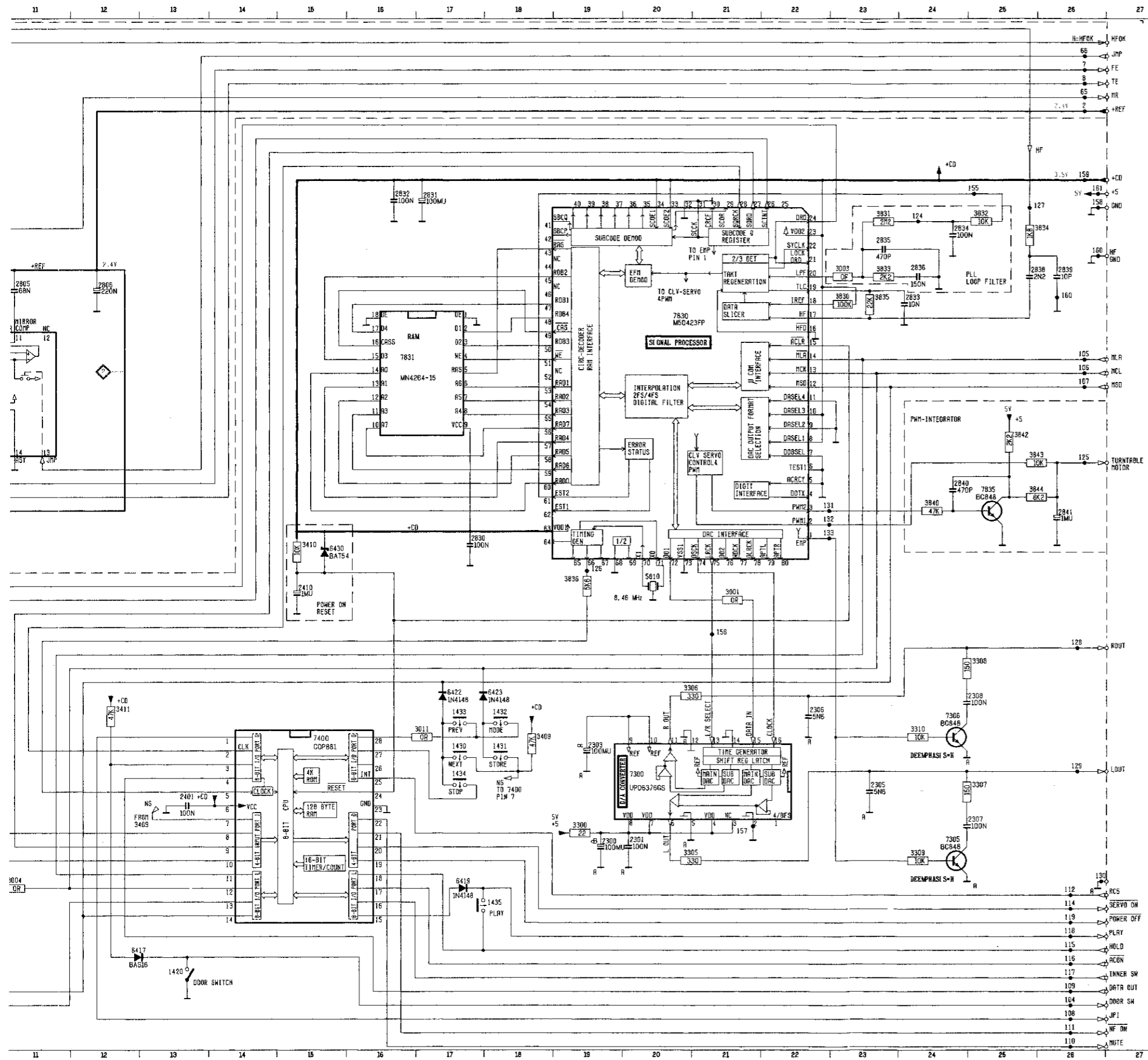

- 1400 J 8
- 1420 N13
- 1430 K17
- 1431 K18
- A 1432 K18
- 1433 K17
- 1434 K17
- 1435 N17
- 1800 E 3
- 2300 L19
- 2301 L20
- B 2303 K19
- 2305 L23
- 2306 K22
- 2307 L24
- 2308 J24
- 2401 L13
- 2410 I15
- 2800 C 8
- 2801 C 6
- C 2802 C 6
- 2803 C 8
- 2804 D 7
- 2805 O11
- 2806 D12
- 2808 H 8
- 2811 K 5
- 2830 H17
- D 2831 C17
- 2832 C16
- 2833 E24
- 2834 D24
- 2835 D23
- 2836 D24
- 2838 D25
- 2839 D26
- E 2840 D24
- 2841 H26
- 3001 I21
- 3003 D23
- 3004 H11
- 3005 N 8
- 3006 M 6
- 3011 K17
- F 3013 L 5
- 3300 L19
- 3305 M20
- 3306 J20
- 3307 L24
- 3308 J24
- 3309 M24
- 3310 K24
- G 3409 K18
- 3410 H15
- 3411 K12
- 3800 B 7
- 3801 C 8
- 3802 D 8
- 3803 D 7
- 3805 D 9
- 3810 G 9
- H 3822 K 6
- 3823 N 5
- 3824 H 4
- 3825 N 4
- 3826 H 4
- 3830 E23
- I 3831 C23
- 3832 C25
- 3833 D23
- 3834 D25
- 3835 E23
- 3836 I19
- 3840 H24
- 3842 G25
- 3843 G25
- 3844 G25
- J 5800 B 9
- 5810 I20
- 6417 N12
- 6419 H17
- 6422 J17
- 6423 H17
- 6430 H15
- K 7300 K20
- 7305 L24
- 7306 K24
- 7400 K15
- 7410 N 8
- F 7800 F 6
- 7820 J 5
- 7821 K 5
- 7822 H 5
- L 7830 E20
- 7831 E16
- 7835 G25
- M
- 112 R
- 114 R
- 119 R
- 118 R
- 115 R
- 116 R
- 117 R
- 109 R
- 104 R
- 108 R
- 111 R
- 110 R
- N
- O



302	B 7	2861	E 6	2902	E 2	3280	C 3	3355	E 8	3403	C 2	5810	C 10	5904	E 2	6401	C 3	6423	D 12	6427	D 4	7831	B 10
306	B 7	2865	E 6	2903	E 3	3282	C 2	3366	E 7	3831	D 11	5901	E 2	5950	E 3	6418	C 3	6424	D 2	6845	E 6	7950	F 3
331	C 8	2890	D 7	2904	E 2	3313	F 8	3400	D 7	3842	F 12	5902	E 2	6250	C 2	6419	E 10	6425	E 3	6850	C 8		
356	D 6	2901	E 1	2960	F 4	3350	F 9	3401	C 8	5800	C 6	5903	E 3	6250	B 3	6422	E 12	6426	D 4	7820	B 6		
		6		7		8		9		10		11		12		13							

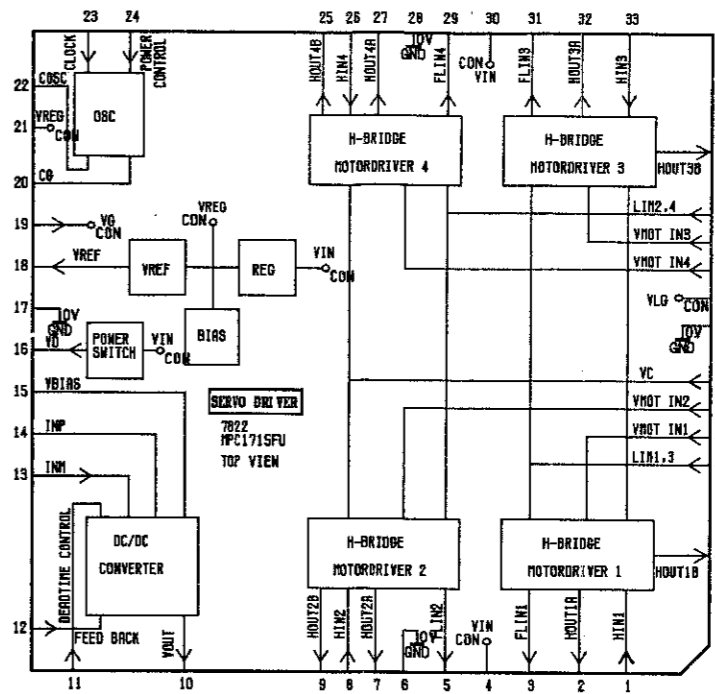
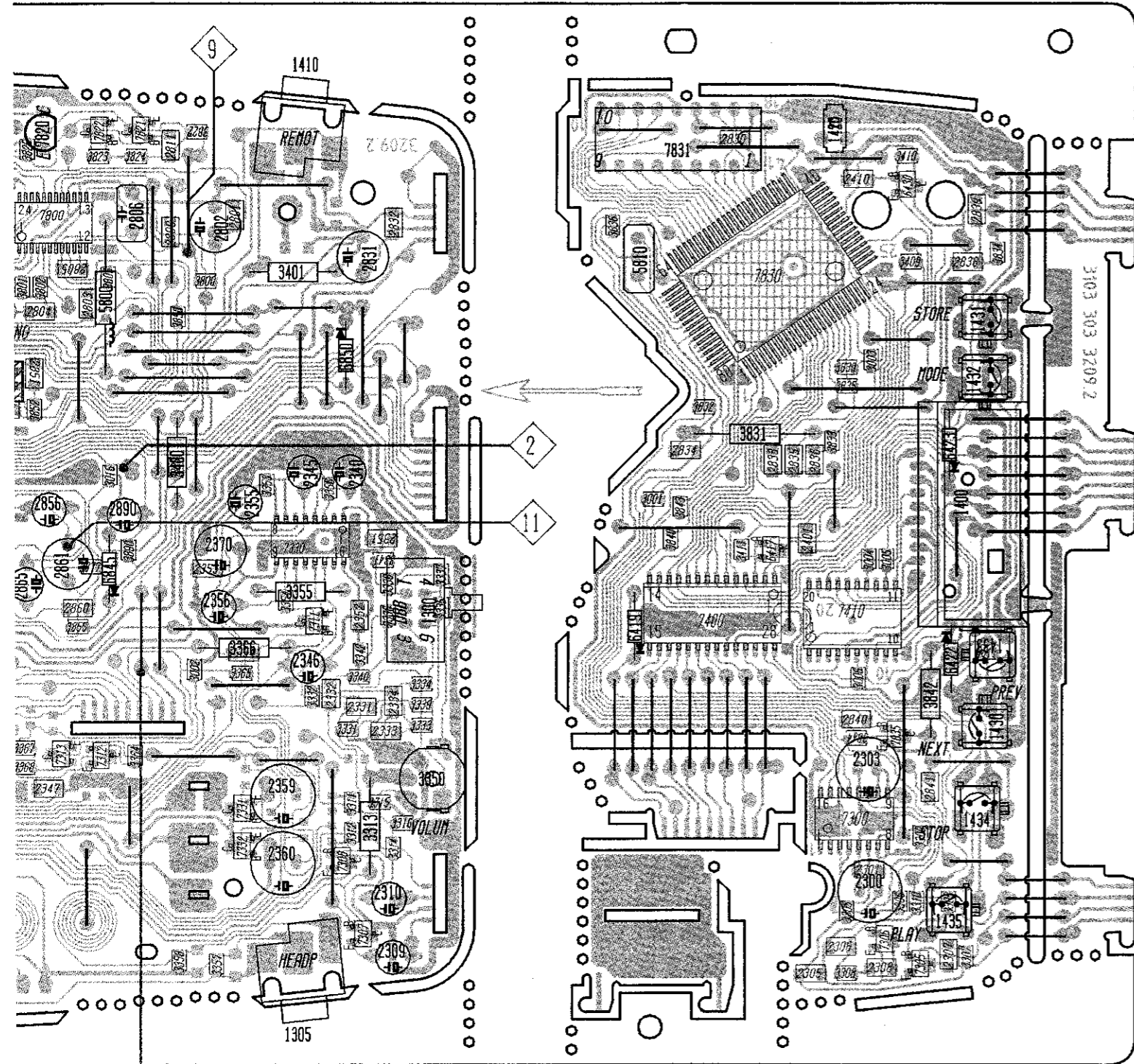

### HANDLING CHIP COMPONENTS

#### GENERAL

SCALE 1:1

SERVICE PACKAGE

#### DISMOUNTING

VACUUM PISTON  
4822 395 10082

SOLDERING IRON  
e.g. WELDER  
SOLDER TIP PT-H7

OR

SOLDERING IRON  
SOLDER WICK  
4822 321 40042

e.g. A PAIR OF TWEEZERS

HEATING

SOLDERING IRON

SOLDER WICK

CLEANING

#### MOUNTING

e.g. A PAIR OF TWEEZERS

SOLDER  
Ø 0.5 - 0.8 mm

SOLDERING IRON

PRESSURE

SOLDERING TIME  
< 3 sec./side

SOLDER  
Ø 0.5 - 0.8 mm

PRESSURE

SOLDERING IRON

#### EXAMPLES

RIGHT

NO!

#### PRECAUTIONS

SOLDERING IRON

RIGHT

COPPER TRACK

SOLDERING IRON

CHIP COMPONENT





CD SERVO & LF-PART

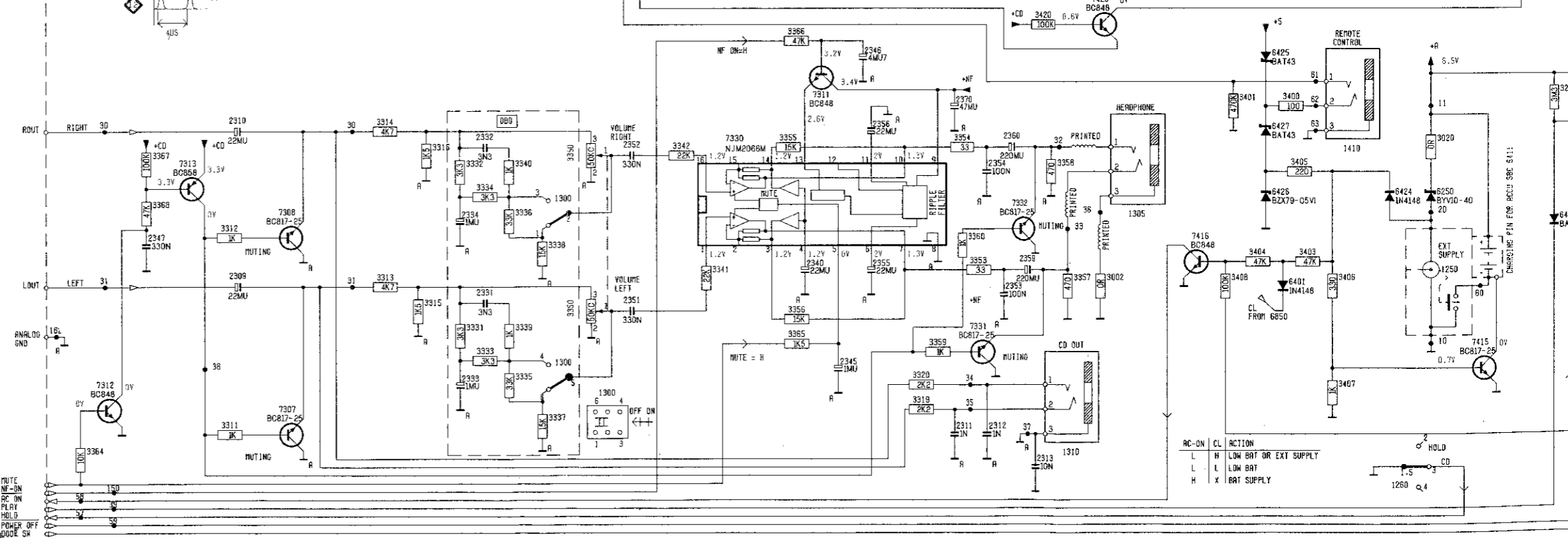
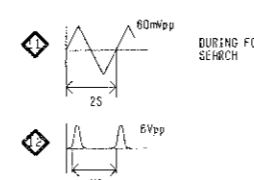
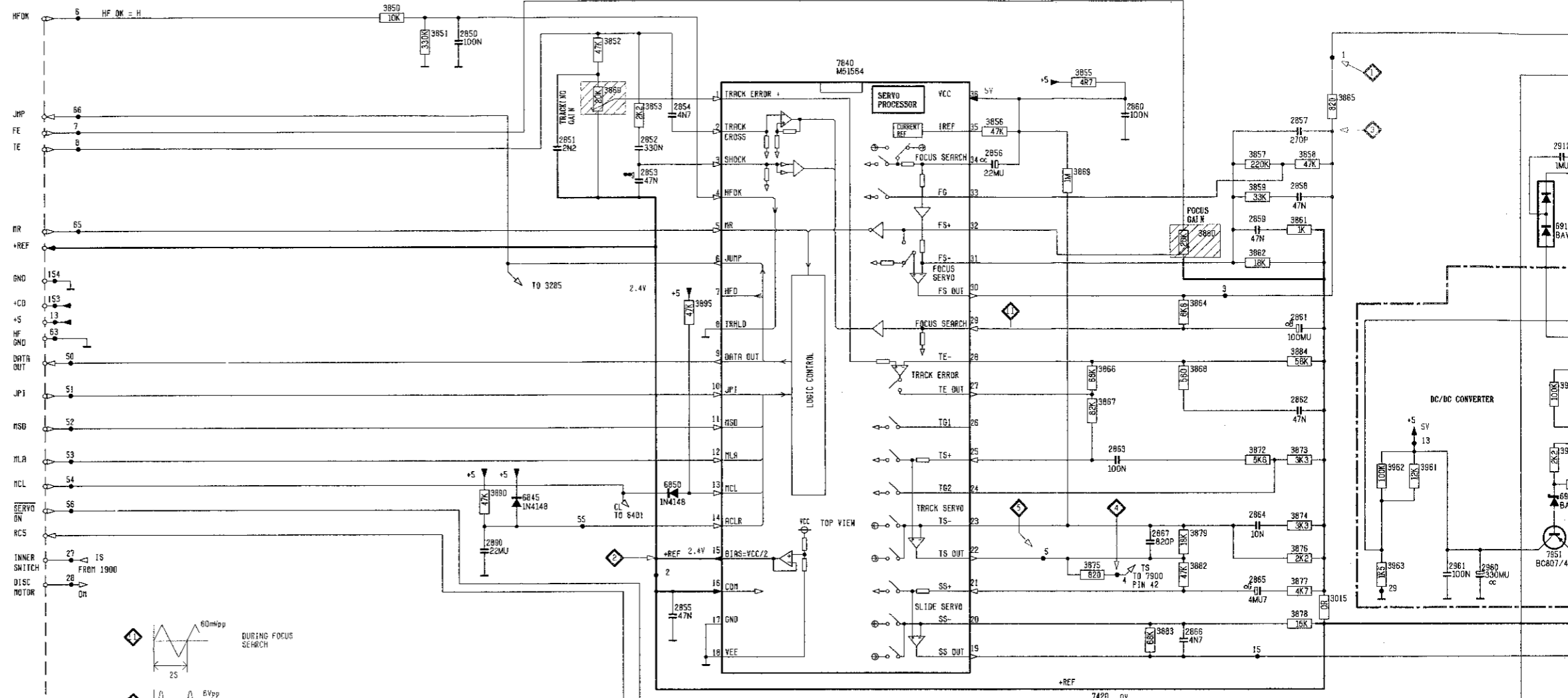

AC-ON	CL	ACTION
H	H	LOW BAT OR EXT SUPPLY
L	L	LOW BAT
H	X	BAT SUPPLY

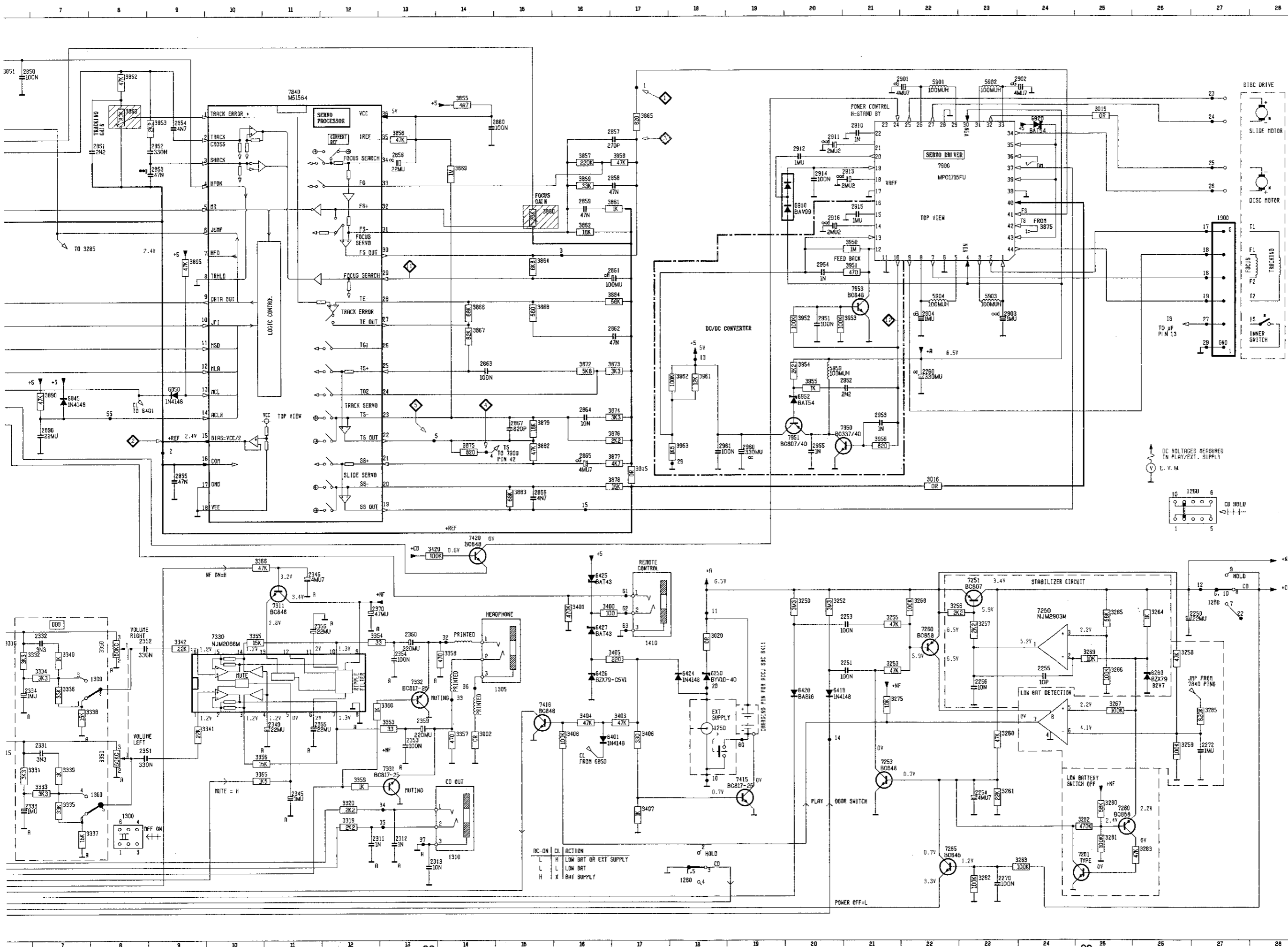

C26	3350	K 8	
F28	3353	M3	
B28	3354	K12	
M18	3355	K10	
A1260	O18	3356	M10
1260	K27	3357	M14
1308	N 8	3358	L14
1300	L 8	3359	M12
1305	L15	3360	L12
1310	O14	3364	O 2
1410	K17	3365	M10
1900	O27	3366	J10
B2256	K26	3367	K 3
C2251	L21	3368	L 3
D2253	K21	3400	M16
2254	M23	3401	K16
2255	L24	3403	M17
2256	L23	3404	M16
2260	G22	3405	L17
2270	O23	3406	M17
C2272	N27	3407	M17
D2309	M 4	3408	M16
2310	K 4	3420	J13
2311	O12	3850	A 6
2312	O13	3851	A 6
2313	O13	3852	B 8
2311	M 7	3853	B 9
2332	K 7	3855	B14
D2333	N 6	3856	C13
2334	L 6	3857	C16
2340	M10	3858	C17
2345	M11	3859	C16
2346	J11	3860	B 8
2347	L 2	3861	O17
2351	M 8	3862	O18
2352	K 8	3864	E15
E2353	M13	3865	B17
2354	L13	3866	F14
2355	M11	3867	F14
2359	K11	3868	F15
2359	M13	3869	C14
2360	K13	3872	G16
2370	K12	3873	G17
H2370	A 8	3874	O17
F2371	C 7	3875	M14
2852	C 8	3876	M17
2853	C 8	3877	M17
2854	B 9	3878	M17
2855	H 9	3879	M15
2856	C13	3880	D15
2857	C17	3882	M15
2858	C17	3883	M15
2859	D16	3884	E17
G2860	B14	3890	O 7
2861	E17	3895	E 9
2862	F17	3950	O21
2863	G14	3951	E21
2864	O16	3952	F20
2865	H16	3953	F20
2868	H15	3954	O20
H2867	H15	3955	O20
2869	H 7	3956	M21
I2901	G 7	3961	G18
2902	B24	3962	G18
2903	F23	3963	M18
2904	F22	5901	B22
2910	B21	5902	B23
2911	C20	5903	E23
2912	C20	5904	E22
I2913	C21	5950	O20
2914	C20	6250	L18
2915	O21	6260	L28
2916	O21	6260	L28
2916	O20	6401	M16
2916	O20	6418	L20
2952	G21	6420	L20
2953	O21	6424	L18
2954	E20	6425	J16
J2955	H20	6426	L16
2956	H19	6427	K16
2961	H18	6845	O 7
3002	M14	6850	G 9
3015	H17	6910	D20
3016	J22	6920	B24
3018	B25	6952	O20
3020	K18	7250	K24
K3250	K20	7251	J23
3252	K20	7253	M21
3253	L21	7250	M22
3255	K21	7255	O22
3256	K22	7260	N25
3257	K23	7261	O25
3258	L26	7307	O 4
3259	M26	7308	L 4
L3260	M23	7311	K11
3261	N23	7312	N 2
3262	O23	7313	L 3
3263	O24	7330	K 9
3264	K26	7331	M13
3265	K25	7332	L13
3266	L25	7415	M19
3267	L25	7416	L15
3268	K22	7420	J14
M3269	L25	7840	B11
3275	L21	7900	C22
3280	N25	7950	M21
N3281	O25	7951	H20
3282	N25	7953	E21
3283	O26		
3285	M27		
N3311	O 4		
3312	L 4		
3313	M 5		
3314	K 5		
3315	M 6		
3316	K 6		
3319	M12		
3320	M12		
3331	N 6		
O3332	L 6		
3333	N 7		
3334	L 7		
3335	N 7		
3336	N 7		
3337	O 7		
3338	M 7		
3339	N 7		
P3340	L 7		
3341	N 9		
3342	K 9		
3350	K 8		

EXPLODED VIEW

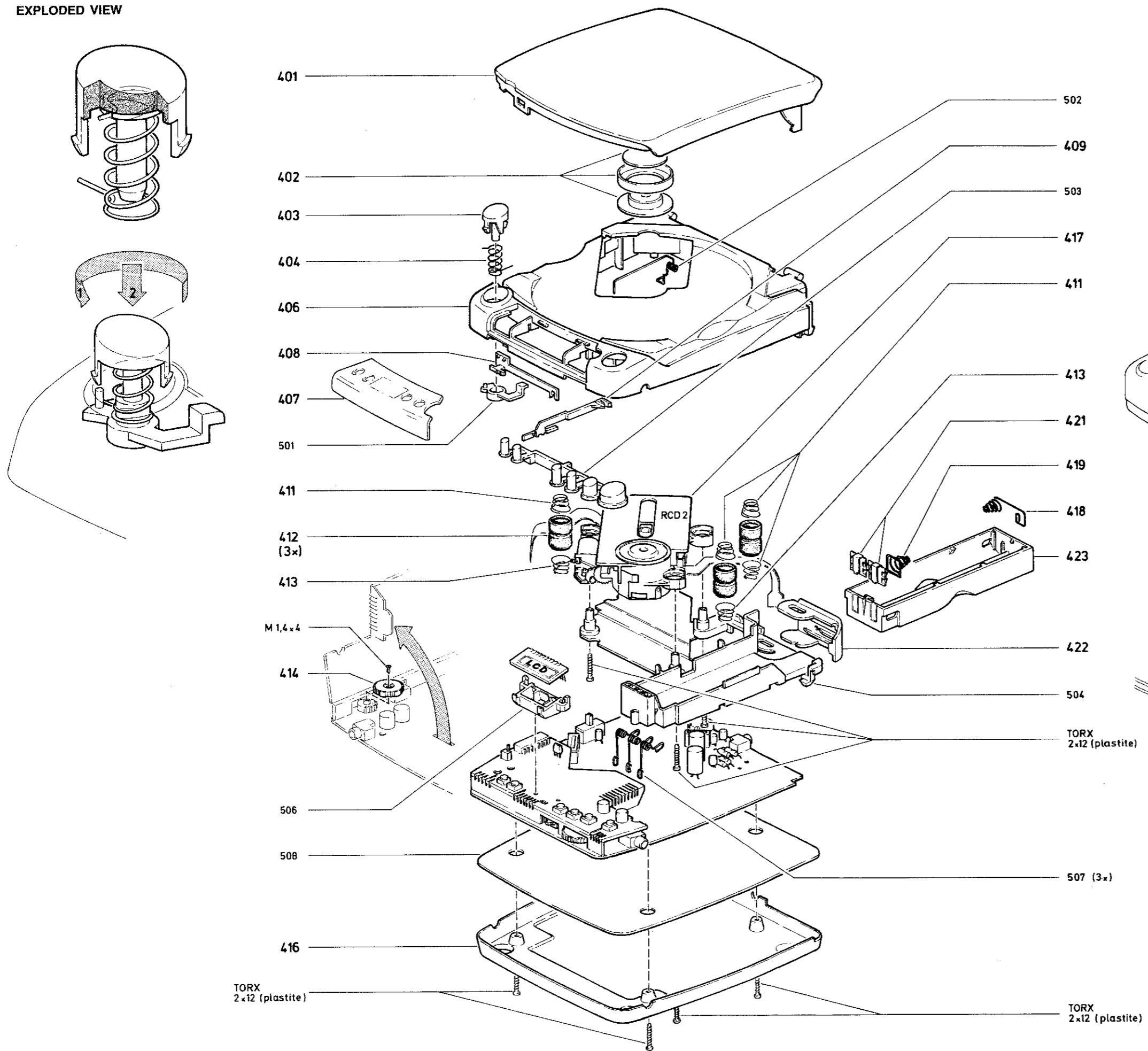

MECHANIC

4822 502
4822 462
4822 502
4822 502
401 4822 444
401 4822 444
402 4822 466
403 4822 410
404 4822 492
406 4822 444
407 4822 450
408 4822 411
409 4822 411
411 4822 492
412 4822 528
413 4822 492
414 4822 413
416 4822 444
417 4822 691
418 4822 492
419 4822 492
421 4822 492
422 4822 444
423 4822 418

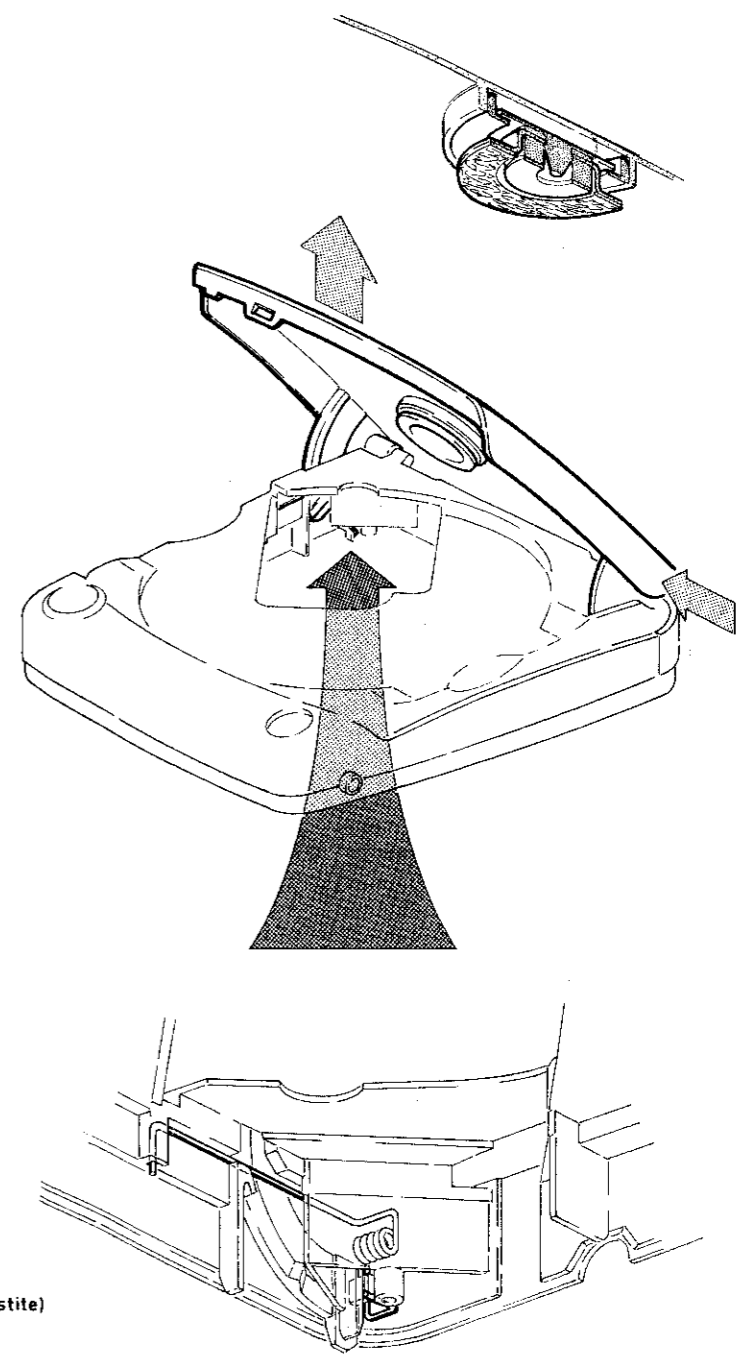

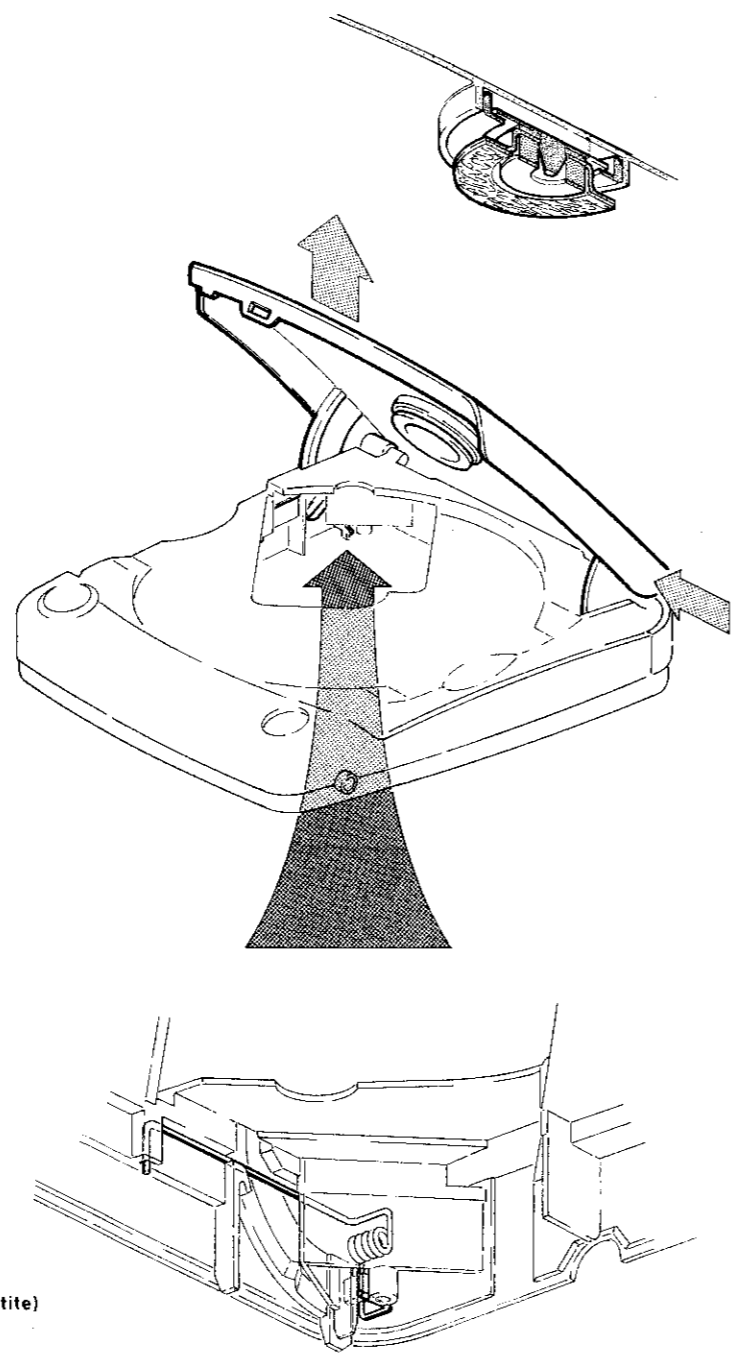
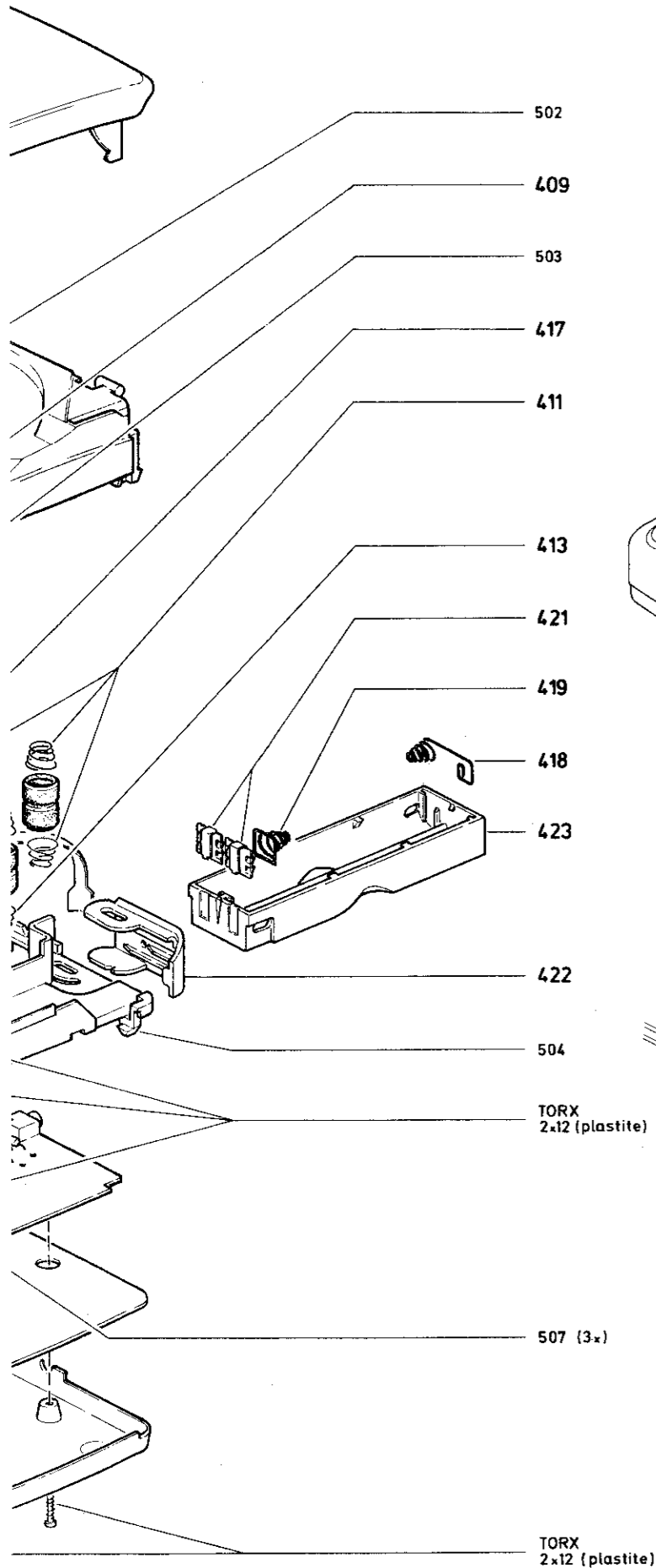

**MECHANICAL PARTS**

4822 502 13769	SCREW M1,4x4
4822 462 41819	RUBBER FOOT
4822 502 30675	SCREW TORX 2x12 PLASTITE
4822 502 30676	SCREW TORX 2x16 PLASTITE
401 4822 444 60768	CD-DOOR PRINTED
401 4822 444 60771	CD-DOOR PRINTED FOR /17
402 4822 466 93031	DISC HOLD DOWN ASSY
403 4822 410 61461	KNOB (EJECT) PRINTED
404 4822 492 70951	SPRING (EJECT)
406 4822 444 40474	CABINET PRINTED
407 4822 450 61769	WINDOW PRINTED
408 4822 411 61829	SLIDER (DBB)
409 4822 411 61831	SLIDER (HOLD) PRINTED
411 4822 492 52147	SPRING COMPRESS
412 4822 529 10256	DAMPER
413 4822 492 70566	SPRING
414 4822 413 31668	VOLUME WHEEL
416 4822 444 50655	BOTTOM (LAQUERED)
417 4822 691 20541	RCD2 - DISC DRIVE
418 4822 492 70955	BATTERY SPRING 3
419 4822 492 70954	BATTERY SPRING 2
421 4822 492 70953	BATTERY SPRING 1
422 4822 444 60767	BATTERY LID
423 4822 418 40883	BATTERY TRAY

MISCELLANEOUS										
1250	4822	600	70642	POUCH						
	4822	498	20125	CARRYING BELT						
	4822	015	20384	SBC3124/PH-HEADPHONE						
	4822	242	40108	SBC3124/MVX-HEADPH.						
	4822	267	31354	SOCKET, EXT. SUPPLY						
1260	4822	277	21235	SWITCH, HOLD SELECT						
1300	4822	276	12892	SWITCH, DBB SELECT						
1305	4822	267	40788	SOCKET, HEADPHONES						
1310	4822	267	31147	SOCKET, CD OUT						
					1400	12NC	FOLLOWS !	LCD	LP0894-A	
					1410	4822	267	31148	SOCKET, REMOTE CONT.	
					1420	4822	276	12889	DOOR SWITCH	
					1430	4822	276	12465	SWITCH TACT	
					1431	4822	276	12465	SWITCH TACT	
					1432	4822	276	12465	SWITCH TACT	
					1433	4822	276	12465	SWITCH TACT	
					1434	4822	276	12465	SWITCH TACT	
					1435	4822	276	12465	SWITCH TACT	
DIODES										
	4822	130	32245	BYV10-40						
	4822	130	82714	BZX79-B2V7						
	4822	130	30621	1N4148						
	5322	130	31928	BAS16						
					4822	130	31353	BAT43		
					4822	130	34233	BZX79-B5V1		
					4822	130	80622	BAT54		
					5322	130	34337	BAV99		
TRANSISTORS										
	4822	130	42132	BC807 (CHIP)						
	4822	130	61207	BC848 (CHIP)						
	5322	130	42012	BC858 (CHIP)						
	4822	130	42804	BC817-25 (CHIP)						
					4822	130	40938	BC548		
					4822	130	41344	BC337-40		
					5322	130	60123	BC807-40 (CHIP)		
INTEGRATED CIRCUITS										
	4822	209	71448	NJM2903M						
	4822	209	62259	UPD6376GS						
	4822	209	30401	NJM2066M						
	4822	209	30311	uP COP881/RUE						
	4822	209	62111	COP472-3						
					4822	209	72814	M51567P		
					4822	209	62112	M50423FP		
					4822	209	70422	MN4264-15		
					4822	209	72815	M51564P		
					4822	209	62261	MPC1715FU		
COILS										
5800	4822	157	53123	100uH						
5810	4822	242	72565	RESONATOR 8,46MHz						
5901	4822	157	53123	100uH						
5902	4822	157	53123	100uH						
					5903	4822	157	53123	100uH	
					5904	4822	157	53123	100uH	
					5950	4822	157	53123	100uH	
RESISTORS										
3280	4822	050	25603	56k	1%	0,6W				
3282	4822	050	24704	470k	1%	0,6W				
3313	4822	050	24702	4k7	1%	0,6W				
3350	4822	100	30071	50k	POTMETER					
3355	4822	116	52244	15k	5%	0,5W				
					3366	4822	050	24703	47k	1% 0,6W
					3401	4822	050	24704	470k	1% 0,6W
					3403	4822	050	24703	47k	1% 0,6W
					3831	4822	050	22205	2M2	1% 0,6W
					3842	4822	050	22202	2k2	1% 0,6W
CHIP RESISTORS										
3001	4822	051	20008	CHIP JUMPER						
3002	4822	051	20008	CHIP JUMPER						
3003	4822	051	20008	CHIP JUMPER						
3004	4822	051	20008	CHIP JUMPER						
3005	4822	051	20008	CHIP JUMPER						
					3257	4822	051	20222	2k2	5% 0,1W
					3258	4822	051	20473	47k	5% 0,1W
					3259	4822	051	20104	100k	5% 0,1W
					3260	4822	051	20473	47k	5% 0,1W
					3261	4822	051	20223	22k	5% 0,1W
					3262	4822	051	20104	100k	5% 0,1W
					3263	4822	051	20104	100k	5% 0,1W
					3264	4822	051	10102	1k	2% 0,25W
					3265	4822	051	20563	56k	5% 0,1W
					3266	4822	051	20104	100k	5% 0,1W
					3267	4822	051	20104	100k	5% 0,1W
					3268	4822	051	20104	100k	5% 0,1W
					3269	4822	051	20103	10k	5% 0,1W
					3275	4822	051	20103	10k	5% 0,1W
					3281	4822	051	20104	100k	5% 0,1W
					3255	4822	051	20473	47k	5% 0,1W
					3256	4822	051	20222	2k2	5% 0,1W
					3283	4822	051	20473	47k	5% 0,1W
					3285	4822	051	20824	820k	5% 0,1W

## CHIP RESISTORS

3300	4822	051	20229	22R	5%	0,1W	3824	4822	051	20473	47k	5%	0,1W
3305	4822	051	20331	330R	5%	0,1W	3825	4822	100	11803	2k2	TRIM POT SMD	
3306	4822	051	20331	330R	5%	0,1W	3826	4822	051	20271	270R	5%	0,1W
3307	4822	051	20151	150R	5%	0,1W	3830	4822	051	20104	100k	5%	0,1W
3308	4822	051	20151	150R	5%	0,1W	3832	4822	051	20103	10k	5%	0,1W
3309	4822	051	20103	10k	5%	0,1W	3833	4822	051	20222	2k2	5%	0,1W
3310	4822	051	20103	10k	5%	0,1W	3834	4822	051	20182	1k8	5%	0,1W
3311	4822	051	10102	1k	2%	0,25W	3835	4822	051	20223	22k	5%	0,1W
3312	4822	051	10102	1k	2%	0,25W	3836	4822	051	20562	5k6	5%	0,1W
3314	4822	051	20472	4k7	5%	0,1W	3840	4822	051	20473	47k	5%	0,1W
3315	4822	051	20152	1k5	5%	0,1W	3843	4822	051	20103	10k	5%	0,1W
3316	4822	051	20152	1k5	5%	0,1W	3844	4822	051	20822	8k2	5%	0,1W
3319	4822	051	20222	2k2	5%	0,1W	3850	4822	051	20103	10k	5%	0,1W
3320	4822	051	20222	2k2	5%	0,1W	3851	4822	051	20334	330k	5%	0,1W
3331	4822	051	20332	3k3	5%	0,1W	3852	4822	051	20473	47k	5%	0,1W
3332	4822	051	20332	3k3	5%	0,1W	3853	4822	051	20222	2k2	5%	0,1W
3333	4822	051	20332	3k3	5%	0,1W	3855	4822	051	20478	4R7	5%	0,1W
3334	4822	051	20332	3k3	5%	0,1W	3856	4822	051	20473	47k	5%	0,1W
3335	4822	051	20333	33k	5%	0,1W	3857	4822	051	20224	220k	5%	0,1W
3336	4822	051	20333	33k	5%	0,1W	3858	4822	051	20473	47k	5%	0,1W
3337	4822	051	20153	15k	5%	0,1W	3859	4822	051	20333	33k	5%	0,1W
3338	4822	051	20153	15k	5%	0,1W	3860	4822	100	11733	20k	TRIM POT SMD	
3339	4822	051	10102	1k	2%	0,25W	3861	4822	051	10102	1k	2%	0,25W
3340	4822	051	10102	1k	2%	0,25W	3862	4822	051	20183	18k	5%	0,1W
3341	4822	051	20223	22k	5%	0,1W	3864	4822	051	20682	6k8	5%	0,1W
3342	4822	051	20223	22k	5%	0,1W	3865	4822	051	20821	820R	5%	0,1W
3353	4822	051	20339	33R	5%	0,1W	3866	4822	051	20683	68k	5%	0,1W
3353	4822	051	20339	33R	5%	0,1W	3867	4822	051	20823	82k	5%	0,1W
3356	4822	051	20153	15k	5%	0,1W	3868	4822	051	20561	560R	5%	0,1W
3357	4822	051	20471	470R	5%	0,1W	3869	4822	051	20135	1M3	5%	0,1W
3358	4822	051	20471	470R	5%	0,1W	3872	4822	051	20562	5k6	5%	0,1W
3359	4822	051	10102	1k	2%	0,25W	3873	4822	051	20332	3k3	5%	0,1W
3360	4822	051	10102	1k	2%	0,25W	3874	4822	051	20332	3k3	5%	0,1W
3364	4822	051	20103	10k	5%	0,1W	3875	4822	051	20821	820R	5%	0,1W
3365	4822	051	20152	1k5	5%	0,1W	3876	4822	051	20222	2k2	5%	0,1W
3367	4822	051	20104	100k	5%	0,1W	3877	4822	051	20472	4k7	5%	0,1W
3368	4822	051	20473	47k	5%	0,1W	3878	4822	051	20153	15k	5%	0,1W
3400	4822	051	10101	100R	2%	0,25W	3879	4822	051	20183	18k	5%	0,1W
3404	4822	051	20473	47k	5%	0,1W	3880	4822	100	11733	20k	TRIM POT SMD	
3405	4822	051	20221	220R	5%	0,1W	3882	4822	051	20473	47k	5%	0,1W
3406	4822	051	20331	330R	5%	0,1W	3883	4822	051	20683	68k	5%	0,1W
3407	4822	051	10102	1k	2%	0,25W	3884	4822	051	20563	56k	5%	0,1W
3408	4822	051	20104	100k	5%	0,1W	3890	4822	051	20473	47k	5%	0,1W
3409	4822	051	20473	47k	5%	0,1W	3895	4822	051	20473	47k	5%	0,1W
3410	4822	051	20223	22k	5%	0,1W	3950	4822	051	20135	1M3	5%	0,1W
3411	4822	051	20473	47k	5%	0,1W	3951	4822	051	20471	470R	5%	0,1W
3420	4822	051	20104	100k	5%	0,1W	3952	4822	051	20104	100k	5%	0,1W
3800	4822	051	10102	1k	2%	0,25W	3953	4822	051	20104	100k	5%	0,1W
3801	4822	051	20153	15k	5%	0,1W	3954	4822	051	20222	2k2	5%	0,1W
3802	4822	051	20153	15k	5%	0,1W	3955	4822	051	10102	1k	2%	0,25W
3803	4822	051	20153	15k	5%	0,1W	3956	4822	051	20821	820R	5%	0,1W
3805	4822	051	20103	10k	5%	0,1W	3961	4822	116	83226	12k	2%	0,1W
3810	4822	100	11733	20k	TRIM POT SMD		3962	4822	051	20104	100k	5%	0,1W
3822	4822	051	20152	1k5	5%	0,1W	3963	4822	116	83225	1k5	2%	0,1W
3823	4822	051	20472	4k7	5%	0,1W							

## CAPACITORS

2250	4822	124	42236	22uF	20%	6,3V	2272	4822	126	11692	1uF		
2254	4822	124	42238	4,7uF	20%	25V	2300	4822	124	42241	100uF	20%	6,3V
2260	4822	124	42242	330uF	20%	6,3V	2303	4822	124	42241	100uF	20%	6,3V

CAPACITORS													
2309	4822	124	42236	22uF	20%	6,3V	2800	4822	122	33064	330nF	20%	25V
2310	4822	124	42236	22uF	20%	6,3V	2802	4822	124	42237	47uF	20%	6,3V
2313	4822	122	10177	10nF	20%	25V	2806	4822	121	42408	220nF	5%	63V
2331	5322	122	33446	3,3nF	10%	63V	2831	4822	124	42234	100uF	20%	6,3V
2332	5322	122	33446	3,3nF	10%	63V	2836	4822	126	11691	150nF	10%	
2333	4822	126	11692	1uF			2841	4822	126	11725	1uF	20%	5V
2334	4822	126	11692	1uF			2852	4822	122	33064	330nF	20%	25V
2340	4822	124	42236	22uF	20%	6,3V	2856	4822	124	42236	22uF	20%	6,3V
2345	4822	124	42239	1uF	20%	50V	2861	4822	124	42234	100uF	20%	6,3V
2346	4822	124	42238	4,7uF	20%	25V	2865	4822	124	42238	4,7uF	20%	25V
2347	4822	122	33064	330nF	20%	25V	2890	4822	124	42236	22uF	20%	6,3V
2351	4822	122	33064	330nF	20%	25V	2901	4822	124	42238	4,7uF	20%	25V
2352	4822	122	33064	330nF	20%	25V	2902	4822	124	42238	4,7uF	20%	25V
2355	4822	124	42236	22uF	20%	6,3V	2903	4822	124	42239	1uF	20%	50V
2356	4822	124	42236	22uF	20%	6,3V	2904	4822	124	42239	1uF	20%	50V
2359	4822	124	42235	220uF	20%	4V	2912	4822	126	11692	1uF		
2360	4822	124	42235	220uF	20%	4V	2915	4822	126	11692	1uF		
2370	4822	124	42237	47uF	20%	6,3V	2960	4822	124	42242	330uF	20%	6,3V
2410	4822	126	11692	1uF									
CHIP CAPACITORS													
2251	4822	122	33496	100nF	10%	63V	2839	4822	122	31971	10pF	10%	50V
2253	4822	122	33496	100nF	10%	63V	2840	4822	122	31727	470pF	5%	63V
2255	4822	122	31971	10pF	10%	50V	2850	4822	122	33496	100nF	10%	63V
2256	4822	122	32442	10nF	10%	50V	2851	4822	122	31644	2,2nF	10%	63V
2270	4822	122	33496	100nF	10%	63V	2853	4822	122	32542	47nF	10%	63V
2301	4822	122	33496	100nF	10%	63V	2854	4822	122	31784	4,7nF	10%	50V
2305	4822	122	31916	5,6nF	10%	63V	2855	4822	122	32542	47nF	10%	63V
2306	4822	122	31916	5,6nF	10%	63V	2857	4822	122	32142	270pF	5%	63V
2307	4822	122	33496	100nF	10%	63V	2858	4822	122	32542	47nF	10%	63V
2308	4822	122	33496	100nF	10%	63V	2859	4822	122	32542	47nF	10%	63V
2311	5322	122	31647	1nF	10%	63V	2860	4822	122	33496	100nF	10%	63V
2312	5322	122	31647	1nF	10%	63V	2862	4822	122	32542	47nF	10%	63V
2353	4822	122	33496	100nF	10%	63V	2863	4822	122	33496	100nF	10%	63V
2354	4822	122	33496	100nF	10%	63V	2864	4822	122	32442	10nF	10%	50V
2401	4822	122	33496	100nF	10%	63V	2866	4822	122	31784	4,7nF	10%	50V
2801	4822	122	31797	22nF	10%	63V	2867	4822	122	32765	820pF	10%	63V
2803	4822	122	31916	5,6nF	10%	63V	2910	5322	122	31647	1nF	10%	63V
2804	4822	122	31769	18pF	5%	50V	2911	4822	124	10965	2,2uF	20%	6,3V
2805	4822	122	32891	68nF	10%	63V	2913	4822	124	10965	2,2uF	20%	6,3V
2808	4822	122	32142	270pF	5%	63V	2914	4822	122	33496	100nF	10%	63V
2811	4822	122	33496	100nF	10%	63V	2916	4822	124	10965	2,2uF	20%	6,3V
2830	4822	122	33496	100nF	10%	63V	2951	4822	122	33496	100nF	10%	63V
2832	4822	122	33496	100nF	10%	63V	2952	4822	122	31644	2,2nF	10%	63V
2833	4822	122	32442	10nF	10%	50V	2953	5322	122	31647	1nF	10%	63V
2834	4822	122	33496	100nF	10%	63V	2954	5322	122	31647	1nF	10%	63V
2835	4822	122	31727	470pF	5%	63V	2955	5322	122	31647	1nF	10%	63V
2838	4822	122	31644	2,2nF	10%	63V	2961	4822	122	33496	100nF	10%	63V